

Shop Manual

PC4000-6

HYDRAULIC MINING SHOVEL

SERIAL NUMBERS PC4000-6 8199 and up

This material is proprietary to Komatsu America Corp. and is not to be reproduced, used, or disclosed except in accordance with written authorization from Komatsu America Corp.

It is our policy to improve our products whenever it is possible and practical to do so. We reserve the right to make changes or improvements at any time without incurring any obligation to install such changes on products sold previously.

Due to this continuous program of research and development, revisions may be made to this publication. It is recommended that customers contact their distributor for information on the latest revision.

Copyright 2013 Komatsu
Printed in U.S.A.
Komatsu America Corp.

January 2013

CLICK HERE TO **DOWNLOAD** THE COMPLETE MANUAL

- Thank you very much for reading the preview of the manual.
- You can download the complete manual from: www.heydownloads.com by clicking the link below



- Please note: If there is no response to CLICKING the link, please download this PDF first and then click on it.

CLICK HERE TO **DOWNLOAD** THE COMPLETE MANUAL

On jobsites where the machine may go close to electric cables, always do as follows.

- Before starting work near electric cables, inform the local power company of the work to be performed, and ask them to take the necessary action.
- Always maintain a safe distance (see the table on the right) between the machine and the electric cable. Check with the local power company about safe operating procedure before starting operations.
- To prepare for any possible emergencies, wear rubber shoes and gloves. Lay a rubber sheet on top of the seat, and be careful not to touch the chassis with any exposed part of your body.
- Use a signalman to give warning if the machine approaches too close to the electric cables.
- When carrying out operations near high voltage cables, do not let anyone near the machine.
- If the machine should come too close or touch the electric cable, to prevent electric shock, the operator should not leave the operator's compartment until it has been confirmed that the electricity has been shut off. Also, do not let anyone near the machine.

Voltage of Cables	Safety Distance
100 V - 200 V	Over 2 m (7 ft)
6,600 V	Over 2 m (7 ft)
22,000 V	Over 3 m (10 ft)
66,000 V	Over 4 m (14 ft)
154,000 V	Over 5 m (17 ft)
187,000 V	Over 6 m (20 ft)
275,000 V	Over 7 m (23 ft)
500,000 V	Over 11 m (36 ft)

2.4.10.7 WORKING ON LOOSE GROUND

- Avoid travelling or operating your machine too close to the edge of cliffs, overhangs, and deep ditches. The ground may be weak in such areas. If the ground should collapse under the weight or vibration of the machine, there is a hazard that the machine may fall or tip over. Remember that the soil after heavy rain or blasting or after earthquakes is weak in these areas.
- When working on embankments or near excavated ditches, there is a hazard that the weight and vibration of the machine will cause the soil to collapse. Before starting operations, take steps to ensure that the ground is safe and to prevent the machine from rolling over or falling.

2.4.10.8 GAS, DUST, STEAM AND SMOKE

WARNING

RISK OF EXPLOSION AND FIRE!

Welding, flame-cutting and grinding work on the machine increases the risk of explosion and fire which may result in serious injury or death.

All relevant safety measures must be followed and only under expressly obtained authorization.

Special care must be taken before welding, flame-cutting and grinding operations are carried out on the counterweight. The filling of the counterweight chambers can create explosive gases which will accumulate in the chambers of the counterweight.

These gases must be expelled before welding, flame-cutting and grinding operations are carried out on the counterweight.

REMARKS: Follow the instructions given in PARTS & SERVICE NEWS No. AH04518 for expelling the gases from the counterweight chambers. (See Volume 2 binder)

2.7.1 FRONT GUARD PROTECTIVE STRUCTURE 'FOPS' FOR OPERATOR'S CAB

The Shovel must be equipped with a front guard protective structure "OPG Front Guard" if it is used for applications where there is a risk of hitting objects from the front.

2.7.2 OBJECT HANDLING

Object handling operations are not allowed.

2.7.3 LIGHTING

The Shovel must only be operated when the operator has sufficient visibility in relation to the work area. Disturbing shady areas or dazzling effects must be avoided.

If necessary, the Shovel must be retrofitted with additional lighting equipment (working lights) in order to ensure sufficient visibility conditions.

2.7.4 WARNING BEACON

The Shovel can be retrofitted with a warning beacon which is fitted on the cab roof by means of a magnetic bracket.

REMARKS: The above-mentioned special safety devices can be ordered as accessories together with the Shovel.
They are also available as a field package for installation through our service organization.

2.7.5 SAFETY HARNESS IN CONFORMITY WITH EN 361 (EUROPEAN STANDARD)

The safety harness should only be used together with connectors according to EN 354, and fall arrest according to EN 355, or fall protection devices according to EN 360.

See the following pages for further information.

2.7.5.1 SAFETY HARNESS IN CONFORMITY WITH EN 361 (EUROPEAN STANDARD)

WARNING

RISK OF FALLING!

Injuries can occur when working in high areas. Always use a Safety Harness (1) in conjunction with a strap type Fall Absorber (2), illust. (Fig. 2-53) before boarding the loader attachment or other unsecured areas on the Shovel.

- The Safety Harness is located in the Cabinet in the Operator's Cab.
- The illustration (Fig. 2-53) shows the standard use of the safety harness with a strap type fall absorber.

8.2.17.3	STICK CYLINDER "PISTON SIDE" FSA	8-47
8.2.17.4	STICK CYLINDER "PISTON SIDE" BHA.....	8-51
8.2.18	STICK CYLINDER "PISTON ROD SIDE" FSA	8-55
8.2.18.1	STICK CYLINDER "PISTON ROD SIDE" BHA.....	8-59
8.2.18.2	BUCKET CYLINDER "PISTON SIDE" FSA	8-63
8.2.18.3	BUCKET CYLINDER "PISTON SIDE" BHA.....	8-67
8.2.18.4	BUCKET CYLINDER "PISTON ROD SIDE" FSA	8-71
8.2.18.5	BUCKET CYLINDER "PISTON ROD SIDE" BHA.....	8-75
8.2.18.6	CLAM CYLINDER "PISTON ROD SIDE" FSA.....	8-79
8.2.18.7	CLAM CYLINDER "PISTON SIDE" FSA.....	8-81
8.2.18.8	CHECKS AND ADJUSTMENTS OF THE LOWERING SPEED	8-83
8.3	HYDRAULICS FOR THE SWING CIRCUIT.....	8-102
8.3.1	SWING CIRCUIT.....	8-102
8.3.2	SWING MOTOR	8-106
8.3.3	SWING GEARBOX (L&S).....	8-108
8.3.4	SWING GEARBOX (SIEBENHAAR).....	8-110
8.3.5	SLEW PARKING BRAKE (L&S).....	8-112
8.3.6	SLEW PARKING BRAKE (SIEBENHAAR)	8-114
8.3.7	SWING BRAKE VALVE	8-116
8.3.8	ELECTRIC / HYDRAULIC FLOWCHART "SWING LEFT"	8-118
8.3.9	ELECTRIC / HYDRAULIC FLOWCHART "SWING RIGHT"	8-120
8.3.10	CHECKS AND ADJUSTMENTS FOR THE SWING CIRCUIT.....	8-122
8.3.11	FUNCTION CHECK FOR THE HYDRAULIC SWING BRAKE	8-128
8.3.12	FUNCTION CHECK FOR THE SLEW PARKING BRAKE	8-130
8.4	HYDRAULICS FOR THE TRAVEL CIRCUIT	8-132
8.4.1	TRAVEL CIRCUIT	8-132
8.4.2	TRAVEL MOTOR	8-136
8.4.3	ROTARY JOINT	8-138
8.4.4	TRAVEL GEARBOX (L&S).....	8-140
8.4.5	TRAVEL GEARBOX (ZOLLERN).....	8-142
8.4.6	TRAVEL PARKING BRAKE (GEAR HOUSE BRAKE)	8-144
8.4.7	TRAVEL BRAKE VALVE.....	8-146
8.4.8	ELECTRIC / HYDRAULIC FLOWCHART "TRAVEL FORWARD"	8-148
8.4.9	ELECTRIC / HYDRAULIC FLOWCHART "TRAVEL BACKWARDS"	8-150
8.4.10	CHECKS AND ADJUSTMENTS FOR THE TRAVEL CIRCUIT.....	8-152
8.4.11	FUNCTION CHECK FOR THE TRAVEL PARKING BRAKE	8-154

9.	HYDRAULIC TRACK TENSIONING SYSTEM	9-1
9.1	GENERAL	9-2
9.2	FUNCTIONAL DESCRIPTION.....	9-4
9.3	PRESSURE DOUBLE STAGE VALVE	9-6
9.4	TENSIONING CYLINDER	9-8
9.5	ADJUSTMENTS / CHECKS.....	9-10

PRECAUTIONS AT JOBSITE

INVESTIGATE AND CONFIRM JOBSITE CONDITIONS

On the jobsite, there are various hidden dangers that may lead to personal injury or death. Before starting operations, always check the following to confirm there are no dangers on the jobsite.

- When carrying out operations near combustible materials, there is a hazard of fire, so be careful when operating.
- Check the terrain and condition of the ground at the worksite, and determine the safest method of operation. Do not operate where there is a hazard of landslides or falling rocks.
- If water lines, gas lines, or high-voltage electrical lines may be buried under the worksite, contact each utility and identify their locations. Be careful not to sever or damage any of these lines (Z 25979).
- Take necessary measures to prevent any unauthorized person from entering the operating area.
- If there is a fire near the machine, there is danger of sparks being sucked in and causing a fire on the machine.
- When travelling or operating in shallow water or on soft ground, check the shape and condition of the bedrock, and the depth and speed of flow of the water before starting operations.
- Maintain the travel path on the jobsite so that there is no obstruction to travel operations.

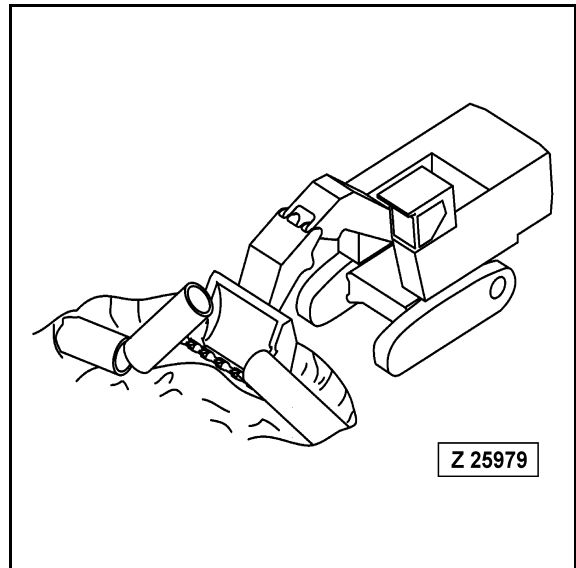

WORKING ON LOOSE GROUND

- Avoid travelling or operating your machine too close to the edge of cliffs, overhangs, and deep ditches. The ground may be weak in such areas. If the ground should collapse under the weight or vibration of the machine, there is a hazard that the machine may fall or tip over. Remember that the soil after heavy rain or blasting or after earthquakes is weak in these areas.
- When working on embankments or near excavated ditches, there is a hazard that the weight and vibration of the machine will cause the soil to collapse. Before starting operations, take steps to ensure that the ground is safe and to prevent the machine from rolling over or falling.

- Position trucks in such a way, that loading operation can be carried out in a safe and economic manner. Avoid swing angles over 90°.

Maintenance

- Preserve our environment. To prevent environmental pollution, pay careful attention to the method of disposing waste materials.
- Always drain fluids from your machine into containers. Never drain fluids onto the ground or dump it into the sewage system, rivers, the sea or lakes.
- Dispose of harmful material, such as oil, fuel, coolant, solvent, filters and batteries in accordance with local environmental regulations and laws.

AIR CONDITIONING MAINTENANCE

WARNING

If air conditioner refrigerant gets into your eyes, it may cause blindness; if it touches your skin, it may cause frostbite. **Never touch refrigerant.**

COMPRESSED AIR

WARNING

When carrying out cleaning with compressed air, there is a hazard of serious injury caused by flying particles.

- When using compressed air to clean elements or the radiator, always wear safety glasses, dust mask, gloves, and other protective equipment.
- Never drop or insert tools or other objects into the fan or fan belt. Parts may break or be sent flying.

Basic values in Ohm according to IEC 751 / EN 60751

Conversion table - Ohm to Centigrade of PT100 sensors

° C	-0	-1	-2	-3	-4	-5	-6	-7	-8	-9
-50	80.31	79.91	79.51	79.11	78.72	78.32	77.92	77.52	77.13	76.73
-40	84.27	83.88	83.48	83.08	82.69	82.29	81.89	81.50	81.10	80.70
-30	88.22	87.83	87.43	87.04	86.64	86.25	85.85	85.46	85.06	84.67
-20	92.16	91.77	91.37	90.98	90.59	90.19	89.80	89.40	89.01	88.62
-10	96.09	95.69	95.30	94.91	94.52	94.12	93.73	93.34	92.95	92.55
0	100.00	99.61	99.22	98.83	98.44	98.04	97.65	97.26	96.87	96.48

° C	0	1	2	3	4	5	6	7	8	9
0	100.00	100.39	100.78	101.17	101.56	101.95	102.34	102.73	103.12	103.51
10	103.90	104.29	104.68	105.07	105.46	105.85	106.24	106.63	107.02	107.40
20	107.79	108.18	108.57	108.96	109.35	109.73	110.12	110.51	110.90	111.28
30	111.67	112.06	112.45	112.83	113.22	113.61	113.99	114.38	114.77	115.15
40	115.54	115.93	116.31	116.70	117.08	117.47	117.85	118.24	118.62	119.01
50	119.40	119.78	120.16	120.55	120.93	121.32	121.70	122.09	122.47	122.86
60	123.24	123.62	124.01	124.39	124.77	125.16	125.54	125.92	126.31	126.69
70	127.07	127.45	127.84	128.22	128.60	128.98	129.37	129.75	130.13	130.51
80	130.89	131.27	131.66	132.04	132.42	132.80	133.18	133.56	133.94	134.32
90	134.70	135.08	135.46	135.84	136.22	136.60	136.98	137.36	137.74	138.12
100	138.50	138.88	139.26	139.64	140.02	140.39	140.77	141.15	141.53	141.91
110	142.29	142.66	143.04	143.42	143.80	144.17	144.55	144.93	145.31	145.68
120	146.06	146.44	146.81	147.19	147.57	147.94	148.32	148.70	149.07	149.45
130	149.82	150.20	150.57	150.95	151.33	151.70	152.08	152.45	152.83	153.20
140	153.58	153.95	154.32	154.70	155.07	155.45	155.82	156.19	156.57	156.94
150	157.31	157.69	158.06	158.43	158.81	159.18	159.55	159.93	160.30	160.67

Legend for Fig. 1-8:

- (1) Cab support (location of the electrical switch board "X2")
- (2) Mounting bolts
- (3) Mounting bolts
- (4) Door
- (5) Door seal
- (6) Door handle (adjustable)

NOTE: For information about bolt connections see OPERATION & MAINTENANCE MANUAL, section Maintenance.

Legend for Fig. 2-3:

- (1) Coupling assembly
- (2) Input drive flange
- (3) Leaf spring assembly
- (4) Output drive flange
- (5) Dip stick
- (6) Bleeder plug
- (7) O-rings
- (8) Spacer
- (E) Engine input flange
- (G) Gearbox output flange

Description of the oil-filled GEISLINGER coupling

The combination of the high elasticity of the leaf springs together with viscous damping by oil displacement ensures that the GEISLINGER-COUPLING removes major critical speeds outside the engine speed range and dampens minor torsional vibrations effectively.

The widest engine speed range free of vibration periods and dangerous resonance is thus obtained.

Furthermore, the employment of this coupling with its highly dampening characteristics generally results in lower stress in all engine driving shafts and gears as well as in the crankshaft, permitting further power development on standard components.

In any similar application, a simple vibration damper and/or a pure flexible coupling would not confer the same advantages.

The springs (Fig. 2-3, Pos. 3) together with the inner driving and outer driven member, form the chambers A and B (Fig. 2-3, Pos. A and B), which are filled with oil.

If the outer member is displaced in relation to the inner member, the deflection of the leaf springs displaces oil from one chamber to the next. By this action the relative movements of the two members of the coupling are braked and the vibrations are dampened.

The spacer (Fig. 2-3, Pos. 8) limits the movement of the leaf springs.

Legend for Fig. 3-1:

- (1) Filter cover retainer
- (2) Filter cover
- (3) Filter element
 - (A) - Return oil filter - 10 µm
 - (B) - Leak oil filter - 3 µm
- (4) Man hole cover
- (24) Pressure switch 40B024 – monitors items (92.1) & (92.2)
- (30) Hydraulic oil level gauge
- (41) Main oil reservoir
- (54) Return oil collector tube with pressure check point M10
- (55) Back pressure valve
- (67) Dust cap for item (77)
- (77) Oil drain, quick release coupling
- (87) Shut-off valve with switch 40B031 (gate valve)
- (88) Compensator
- (91.1 + 92.2) Breather filter

The hydraulic oil tank is a welded sheet-metal construction.

The tank has a filling volume of approx. 3900 litres. The tank contains four return oil filters (Fig. 3-1, Pos. A) and one leak oil filter (Fig. 3-1, Pos. B).

The breather filter (Fig. 3-1, Pos. 92.1 + 92.2) cleans the air that streams into the tank.

The back pressure valve (Fig. 3-1, Pos. 55) and the pressure check point (Fig. 3-1, Pos. M10) are located at the collector pipe (Fig. 3-1, Pos. 54) for return oil.

The connection to the suction tank can be closed with the shut-off valve (Fig. 3-1, Pos. 87) in order to prevent oil flow during repairs on the hydraulic pumps. This gate valve is controlled by the switch 40B031. It ensures that engine start is not possible while the shut-off valve is closed. Fault message "Start blocked because of main Shut-Off (gate) Valve" is displayed at the VHMS monitor.

Legend for Fig. 4-4:

(5.1)	Axial piston pump (fixed displacement pump with variable setting)
(31.1)	Pressure relief valve, pilot controlled (maximum fan speed)
(34.1)	Pressure filter
(37.1)	Fan motor top (axial piston motor)
(37.2)	Fan motor bottom (axial piston motor)
(38)	Check valve – (anti-cavitation valve for fan drive motor)
(124)	Pressure relief valve (medium fan speed)
(57K506a/b-1)	Solenoid valve
(M6)	Pressure check point

Function

From the pump (Fig. 4-4, Pos. 5.1) the oil flows through the pressure filter (Fig. 4-4, Pos. 34.1) to the fan motors (Fig. 4-4, Pos. 37.1 + 37.2) and then back to the tank.

The check valve (Fig. 4-4, Pos. 38) acts as an anti-cavitation valve. It is installed because the fan motor (driven by inertial force) keeps on running for a short period after the oil flow is interrupted by the solenoid valve (Fig. 4-4, Pos. 57K506a/b-1).

The fan drive circuit is protected by the pilot controlled pressure relief valves (Fig. 4-4, Pos. 31.1) and (Fig. 4-4, Pos. 124).

These valves are working together with the solenoid valve (Fig. 4-4, Pos. 57K506a/b-1), controlled by the VHMS system, depending on the hydraulic oil temperature.

- With de-energized solenoids 57K506a-1 and 57K506b-1 the relief valve (Fig. 4-4, Pos. 31.1) is operating and the fans are running with max. adjusted speed (1250 ± 50 rpm).
- With solenoid 57K506a-1 energized the relief valve (Fig. 4-4, Pos. 31.1) is not operating and the fans are running with a very low speed caused by the flow resistance only.
- With solenoid 57K506b-1 energized the relief valve (Fig. 4-4, Pos. 124) is controlling the relief valve (Fig. 4-4, Pos. 31.1) and the fans are running with medium speed (1000 ± 10 rpm) only.

Legend for Fig. 5-5:

(20S019)	Electro proportional joystick control
(20S020)	Electro proportional joystick control
(20S021a)	Electro proportional pedal control, travelling of left crawler
(20S021b)	Electro proportional pedal control, travelling of right crawler
(20S022)	Electro proportional pedal control, swing brake
(20S023)	Electro proportional pedal control, closing of the clam
(20S024)	Electro proportional pedal control, opening of the clam
(M1.1)	Pressure test port, X4 pressure. (Pump bearing lubrication, pump support pressure (60+3 bar)) CLS SLS
(M1.2)	Pressure test port, X2 pressure. Pilot pressure (45+3 bar), bracke control, pump regulation.
(8.1)	Gear pump for pilot pressure, pump regulation and pump bearing lubrication
(14.1/2+15.1/.2)	Remote control valve blocks
(33)	Pressure filter
(35)	Valve cartridge block
(41)	Main hydraulic oil tank
(85)	Bladder accumulator – 10 liters, 10 bar (located underneath the catwalk in front of the PTO)
(252.1)	Pressure relief valve for pilot pressure X2 (45+3 bar)
(252.2)	Pressure relief valve for pump support pressure X4 (60+3 bar)

5.3.1 PILOT PRESSURE CONTROL (PPC) CIRCUIT

The pilot pressure oil is used for the following functions:

To operate the control block spools, to supply the main pump regulation system, to lubricate the main pump bearings, to release the travel- and swing gear house brakes (spring loaded multi disk brakes), to drive the grease pumps and to supply the hydraulic track tensioning system.

Function

NOTE: For further details refer to the hydraulic circuit diagram!

The pump (Fig. 5-5, Pos. .8.1) delivers the oil through the pressure filter (Fig. 5-5, Pos. 33) to port "A" of the pressure relief valve (Fig. 5-5, Pos. 252.2) to limit the pump support pressure X4 (60+3 bar).

The pressure reducing valve (Fig. 5-5, Pos. 252.1) maintains the adjusted pressure of 45+3 bar (X2) for the pilot pressure system, the pump regulation system and the supply for some auxiliary systems.

The pressure accumulator (Fig. 5-5, Pos. 85) holds a certain amount of oil under pressure to provide sufficient pilot pressure during normal operation, and to ensure a limited number of lowering operations with the main drive motor at standstill.

NOTE: The adjustment of the amplifier for the swing brake is slightly different from the adjustment procedures for the amplifiers of the other foot pedals and the joysticks, also refer to section 5.10.3 on page 5-58.

Adjustment procedure for the amplifier of the swing brake (foot pedal):

1. Open* the respective separating terminal (Fig. 5-17, Pos. T1) between the pedal unit and the amplifier module to be set.
2. Open* the respective separating terminal (Fig. 5-17, Pos. T2) between the amplifier module to be set and the proportional solenoid valve.
3. Disconnect the wire from the amplifier, terminal 5.
4. Connect the positive output of the service module with terminal 5 of the amplifier module using a test lead (Fig. 5-17, Pos. 2).
5. Attach a multimeter for voltage reading to the service module using test leads (Fig. 5-17, Pos. 3).
6. Attach a multimeter (in series) for ampere reading to the terminals between the amplifier module and the solenoid valve using test leads (Fig. 5-17, Pos. 3).
7. Press the swing brake pedal fully down, or manually override the relay supplying the amplifier module with 24 VDC operating voltage. (Thus, the amplifier gets 24 V operating voltage.)
8. Turn the potentiometer (Fig. 5-17, Pos. P) of the **service module** until the multimeter for voltage reading shows **1 VDC**; the multimeter for the current reading will show a value that should correspond to the value given in the circuit diagram, e.g. **40 mA** (10% value). **If necessary correct the value with the potentiometer** (Fig. 5-17, Pos. R1).
9. Turn the potentiometer (Fig. 5-17, Pos. P) of the **service module** until the multimeter for voltage reading shows **10 VDC**; the multimeter for the current reading will show a value that should correspond to the value given in the circuit diagram, e.g. **350 mA** (100% value). **If necessary correct the value with the potentiometer** (Fig. 5-17, Pos. R2).

NOTE: It is important that the pilot pressure for the pressure increasing valve is 24 ± 1 bar. For more information refer to section 8.3 on page 8-102.

* How to open and close the terminal:

Push the yellow stud (Fig. 5-17, Pos. 1) down with a screw driver and turn it 90° to the left to open or to the right to close the terminal. Then a spring pushes the stud outwards and the contacts are either open or closed.

Legend for Fig. 6-8:

- (1) Pilot pressure supply port (marked with P)
- (2) Pilot pressure return port to tank (marked with L)
- (3) Pilot pressure output lines to the control block
- (4) Proportional solenoid valve
- (5) 4/3 Directional solenoid valve

NOTE: Remote control valves are part of the electric-hydraulic control system.

Function

The electric-hydraulic control system is used to control the direction and volume of oil flow to the operating cylinders and motors via the main control valve blocks.

When a lever (or pedal) is actuated, a proportional solenoid valve (Fig. 6-8, Pos. 4) and one of the directional solenoid valves (Fig. 6-8, Pos. 5 / either Ax or Bx) are energized, allowing the pilot pressure oil to flow to the spools of the main control blocks.

The proportional solenoid valve alters the pilot pressure, proportional to the lever deflection, resulting in a spool movement in the main control block between neutral and full stroke position.

Legend for Fig. 6-20:

- (1) Housing
- (2) Control spool
- (3) Plunger
- (4) Solenoid
- (5) Dust cap with stem for manual operation
- (6) Return spring

NOTE: These solenoid operated directional spool valves are installed to control the start, stop, and direction of an oil flow.

Function

When there is no flow through the valve, the control spool (Fig. 6-20, Pos. 2) is held in neutral or output position by means of the return springs (Fig. 6-20, Pos. 6). The control spool (Fig. 6-20, Pos. 2) is operated by means of oil immersed solenoid (Fig. 6-20, Pos. 4).

The force of the solenoid (Fig. 6-20, Pos. 4) effects the control spool (Fig. 6-20, Pos. 2) by means of the plunger (Fig. 6-20, Pos. 3) and pushes it from its resting position to the required end position.

This results in free flow from or P to B and A to T.

When the solenoid (Fig. 6-20, Pos. 4) is de-energized, the control spool (Fig. 6-20, Pos. 2) is moved back to its resting position by means of return springs (Fig. 6-20, Pos. 6).

An optional emergency operating device for manual operation (Fig. 6-20, Pos. 5) allows movement of the control spool (Fig. 6-20, Pos. 2) without energizing the solenoid.

Legend for Fig. 7-8:

- | | | | |
|------|----------------------------|------|--------------------------------------|
| (1) | Drive shaft | (11) | Drive through (auxiliary pump drive) |
| (2) | Cylindrical roller bearing | (12) | Swash plate |
| (3) | Slide shoes | (13) | Q _{min} stop bolt |
| (4) | Angle indicator | (14) | Power control valve |
| (5) | Servo piston | (15) | Pressure balance valve |
| (6) | Rocker cam | (16) | Power curve correction |
| (7) | Barrel with pistons | (17) | Pressure cut-off valve |
| (8) | Case (rear) | (18) | Q _{max} stop bolt |
| (9) | Cylindrical roller bearing | (19) | Remote control valve |
| (10) | Impeller pump | | |

Main hydraulic pump **A4VSO750i**

Type code explanation:

A4VSO	750	i	L
		Series	Rotation
	Displacement in cm ³ at one (1) revolution		
Axial piston pump series 4, variable displacement ,swash plate design for open circuits with charge pump			

Function and Characteristics:

- The A4VSO750i variable displacement axial piston pump in swash plate design is intended for drives in open circuit operation.
- The flow volume is proportional to the drive speed and the displacement. By adjusting the swash plate an infinitely variable flow adjustment is possible.
- Pumps of the same nominal size can be built onto the trough drive. Combinations with gear pumps are also possible.

7.3.1 ELECTRONIC LOAD LIMITING CONTROL - GENERAL

The drive train of the excavator consists of a Diesel engine, several hydraulic pumps, which supply cylinders and hydraulic motors.

The load limiting control ensures optimum use of the power required for the excavator under varying operating conditions and avoiding overload of the Diesel engine.

Fig. 7-20 shows the principle of the electronic load limiting control.

The RC4-4 (10K032) processes the following input signals:

- Diesel engine speed (Pin 33) from magnetic pick-up (52B064).
- Switch signal (Pin 37) from engine control (25K014-1), 24 V if $n > 300$ rpm.

The RC4-4 (10K032) processes the following output signals:

- Signal value to control the proportional solenoid valve 57K561-1 (Pin 31).
- Switch signals (Pin 15 and 29), diagnostic of the RC4-4 (10K032).

The Diesel engine drives four variable displacement pumps by means of a PTO-gearbox.

Each pump is equipped with a hydraulic power controller (HPC).

This controller limits the input torque of the pump to an adjusted command value (X1-pressure, for start of destrok-ing).

The command value (X1-pressure) is present via proportional solenoid valve 57K561-1 at the hydraulic power controllers of each pump.

The actual speed of the engine is measured with a speed sensor at the flywheel.

NOTE: The auxiliary hydraulic pumps and other consumers can be operated without being directly affected by the load limiting control.

The control algorithm of the load limiting control always compares the actual engine speed with the rated load speed.

With increasing load the engine torque will rise and the engine speed will drop.

For this reason the electronic load limiting control will be initiated when the load speed falls below 1800 rpm, i.e. the torque of the main pumps will be lowered (by reducing the X1-pressure) until the rated speed of 1800 rpm is attained again.

If adjustment is required:

Change the setting at pressure control valve (152):

1. Loosen lock nut (Fig. 7-36, Pos. a) of the pressure control valve.
2. Turn the set screw (b) of the pressure control valve (152) clockwise to reduce or counterclockwise to increase the sprocket speed. Adjust the sprocket speed according to the table below.
3. Lock set screw by tightening the lock nut.

Pump flow control test values

No.	Function	57K646	57K647	57K648	57K626	Left sprocket Time/5 revs.	Right sprocket Time/5 revs.
1	Travel right only	0 V	0 V	0 V	24 V	50±1 sec	50±1 sec
2	Travel right and swing (low speed)	24 V	24 V	24 V	24 V	65±1 sec	65±1 sec
3	Travel right and swing (high speed)	24 V	0 V	0 V	0 V	65±1 sec	65±1 sec
4	Travel left only	0 V	0 V	0 V	24 V	50±1 sec	50±1 sec
5	Travel left and swing (low speed)	24 V	24 V	24 V	24 V	65±1 sec	65±1 sec
6	Travel left and swing (high speed)	24 V	0 V	0 V	0 V	65±1 sec	65±1 sec

Fig. 7-38 Pump flow control test values

NOTE: Switch swing speed between low and high with switch 20S154 at the left control lever.

5 revolutions of the sprocket within 65 seconds are mandatory to determine the optimized pump flow.

The pressure control valve (152) is factory preset to 18 bar, a field test / adjustment after comissioning is necessary.

Legend for Fig. 8-11:

(20S019)	Control lever (joystick)
(XB)	Direction (axis) of joystick
(-10V)	Signal voltage (maximum)
(11X_00...)	Terminal rail with number
(11T009) (11T009a) (11T009b)	Amplifier module – bucket
(11T010b)	Amplifier module – boom up or bucket fill when not raising the boom.
(11K050)	Relay – pilot control: bucket cut-off. Contacts 11/12 only closed if the hydraulic oil is overheated.
(11K058)	Relay – pilot control: Contacts 6/10 and 5/9 only closed while lifting the boom.
(11K071)	Relay – pilot control: Contacts 6/10 and 5/9 only closed while filling the bucket.
(11K074)	Relay – pilot control: Contacts 5/9 only closed while extending the stick.
(11K076)	Relay – pilot control: Contacts 6/10 only closed while traveling the left crawler.
(11K078)	Relay – pilot control: Contacts 7/11 only closed while traveling the right crawler.
(14.1 + 14.2) (15.1 + 15.2)	Remote control valves
(61K569) (61K564) (61K571) (61K575)	Proportional solenoid valve
(61K522) (61K532) (61K536) (61K544)	Directional solenoid valve
(I - IV)	Main control blocks I - IV
(42)	Distributor manifold

Electrical signal flow

Signal voltage of joystick (Fig. 8-11, Pos. 20S019) goes via relay contacts at terminal 5 of the amplifier modules (Fig. 8-11, Pos. 11T009, 11T009a, 11T009b and 11T010b) and further to the proportional and directional solenoid valves of the remote control blocks (Fig. 8-11, Pos. 14.1, 14.2, 15.1 and 15.2).

Hydraulic signal flow (pilot pressure)

When the proportional and directional solenoid valves are energized, pilot pressure oil flows to the pilot pressure ports of the main control blocks.

Hydraulic oil flow

Now the oil of the main pumps flows through the main control blocks (I to IV) and via distributor manifold (Fig. 8-11, Pos. 42) to the hydraulic cylinders.

8.2.17.3 STICK CYLINDER "PISTON SIDE" FSA

There are 4 secondary relief valves (SRV) installed, 3 at the distributor manifold (Fig. 8-23, Pos. 42) and 1 in main control block IV, to limit the maximum possible pressure peaks in the lines.

Since the opening pressure of the SRVs is higher than the setting of the main relief valves (MRV), it is necessary to increase the main relief pressure for testing and adjusting purposes.

Valve	Press. test port	Location
SRV 66.11	M13 (High pressure filter)	Control block IV, section A3
SRV 65.2	M20	Manifold (Fig. 8-23, Pos. 42), section G
SRV 70.8	M21.1	Manifold (Fig. 8-23, Pos. 42), section J
SRV 70.9	M13 (High pressure filter)	Control block IV

1. Connect gauges to all test ports listed above.
2. Start engine and let it run at high idle.
3. Extend the stick cylinder to the stop position until the hydraulic system stalls.
4. Slowly increase the pump circuit pressure by turning in set-screws (Fig. 8-23, Pos. 3) of the MRV in control block IV, while observing the pressure gauges. Stop as soon as the pressure does not rise any further. The gauge pointers should remain at 350 ± 5 bar.

NOTE: Since the piston side of the stick cylinders are protected by several SRVs, the pressure gauges show the pressure of the valve with the lowest setting. Even if the gauges show the required pressure, it is possible that one or more valves have a higher setting.

To ensure that only the SRVs open during checks and adjustments, it is necessary to further increase the setting of the MRVs.

5. Remove protective cap (Fig. 8-23, Pos. 1) of MRV.
6. Loosen lock nut (Fig. 8-23, Pos. 2).
7. Turn set-screw (Fig. 8-23, Pos. 3) of the MRV $\frac{1}{2}$ a turn further in; the gauge pointers will remain at the value shown in step 4 (350 ± 5 bar).
8. Tighten lock nut (Fig. 8-23, Pos. 2) and install cap (Fig. 8-23, Pos. 1).

8.2.18.4 BUCKET CYLINDER "PISTON ROD SIDE" FSA

There are 2 secondary relief valves (SRVs) installed, 1 in main control block III, and 1 in block IV, to limit the maximum possible pressure peaks in the lines.

Since the opening pressure of the SRVs is higher than the setting of the main relief valves (MRVs), it is necessary to increase the main relief pressure for testing and adjusting purposes.

Valve	Pressure Test Port	Location
SRV 66.2	M11 (High pressure filter)	Control block III, section B2
SRV 66.10	M13 (High pressure filter)	Control block IV, section B2
MRV circuit III	M11 (High pressure filter)	Control block III
MRV circuit IV	M13 (High pressure filter)	Control block IV

1. Connect gauges to all test ports listed above.
2. Start engine and let it run at high idle.
3. Retract the bucket cylinder to the stop position until the hydraulic system stalls.
4. Slowly increase the pump circuit pressure by turning in set-screws (Fig. 8-35, Pos. 3) of MRVs in the control blocks, while observing the pressure gauges. Stop as soon as the pressure does not rise any further. The gauge pointers should remain at 350 ± 5 bar.

NOTE: Since the piston rod side of the bucket cylinders are protected by several SRVs, the pressure gauges show the pressure of the valve with the lowest setting. Even if the gauges show the required pressure, it is possible that one or more valves have a higher setting. To ensure that only the SRVs open during checks and adjustments, it is necessary to further increase the setting of the MRVs.

5. Remove protective cap (Fig. 8-35, Pos. 1) of MRV.
6. Loosen lock nut (Fig. 8-35, Pos. 2).
7. Turn set-screw (Fig. 8-35, Pos. 3) of both MRVs $\frac{1}{2}$ a turn further in.
8. Tighten lock nut (Fig. 8-35, Pos. 2) and install cap (Fig. 8-35, Pos. 1).

Stick cylinder BHA**Maximum permissible lowering speed:**

Refer to the PM-CLINIC sheet for your machine.

Adjustments / checks:

1. Use a stop watch to measure the time for the cylinder movement.
2. Raise the fully extended attachment with empty bucket to the maximum height position (Fig. 8-47, Pos. A).
3. Run the engine at high idle.
4. Rapidly move the control lever (Fig. 8-47, Pos. 20S020) to the rear end position (start the stop watch) and hold it until the final position (Fig. 8-47, Pos. B) is reached (stop the stop watch).
5. If the lowering speed is too high (measured time is less than the permissible time), the speed must be reduced by **adjusting the throttle valves 70.8, 70.9 and 70.10 at the distributor manifold** (Fig. 8-47, Pos. 42).
Adjust as follows:
 - To decrease the lowering speed, loosen the lock nut (Fig. 8-47, Pos. 2) and turn the bolt (Fig. 8-47, Pos. 1) clockwise.
 - To increase the lowering speed, loosen the lock nut (Fig. 8-47, Pos. 2) and turn the bolt (Fig. 8-47, Pos. 1) counter-clockwise.

NOTE: There are several throttle valves mounted in the return line. The return oil flow of the boom cylinder through the throttle valves must be set synchronously. All valves have to be adjusted in a way the bolts are turned in by the same amount of revolutions.

6. Check lowering speed again and repeat the adjustment, if necessary.
7. If the adjustment is finished, tighten lock nut (Fig. 8-47, Pos. 2).

Legend for Fig. 8-60:

(20S020)	Control lever (joystick)
(20S022)	Control pedal swing brake
(-X)	Direction (axis) of joystick
(-10V)	Signal voltage (maximum)
(11X_...)	Terminal rail with number
(11T050 / 50a / 50b)	Ramp time modules
(11T007)	Amplifier module – swing (61K565 + 61K524 / 61K525 - Block III)
(11T007a)	Amplifier module – swing (61K566 + 61K526 / 61K527 - Block I)
(11T016)	Amplifier module – swing brake
(11K080)	Relay - Contacts 7/11 only closed while rotating with swing speed switch 20S154 activated and not lifting the boom.
(11Q190)	Relay - Swing brake without ramp time - Contacts 5/9 and 6/10 only closed while using the brake pedal
(14.1 + 14.2)	Remote control valve block
(61K565 + 61K566)	Proportional solenoid valve
(61K524 + 61K526)	Directional solenoid valve
(61QK627)	Proportional solenoid valve
(I + III)	Main control blocks I + III
(16.2)	Distributor manifold
(61.1 + 61.2)	Swing brake valve block
(DSV)	Double stage valve
(60.1 + 60.2)	Swing motor
(270.1 + 270.2)	Shuttle valve

The electrical signal

Signal voltage of joystick (Fig. 8-60, Pos. 20S020) arrives via ramp time modules (Fig. 8-60, Pos. 11T050/a) at terminal 5 of the amplifier modules (Fig. 8-60, Pos. 11T007 + 11T007a) and further to the proportional and directional solenoid valves of the remote control blocks (Fig. 8-60, Pos. 14.1 + 14.2). Simultaneously, signal voltage arrives via ramp time modules (Fig. 8-60, Pos. 11T050b) at terminal 5 of the amplifier modules (Fig. 8-60, Pos. 11T016) and further to the proportional valve (Fig. 8-60, Pos. 57Q627).

Pilot pressure

When the proportional and directional solenoid valves are energized, pilot pressure oil flows to the pressure ports of the main control blocks and to the double stage valves (Fig. 8-60, Pos. DSV).

Main hydraulic oil flow

Now the oil of the main pumps flows through the main control blocks (Fig. 8-60, Pos. I + III) and arrives via swing brake valves (Fig. 8-60, Pos. 61.1 + 61.2) at the swing motors (Fig. 8-60, Pos. 60.1 + 60.2).

Legend for Fig. 8-75:

- (1) Input drive shaft
- (2) Parking brake housing
- (3) Motor adapter
- (4) Spur gear
- (5) Sun gear, first stage
- (6) Planetary ring gear, first stage
- (7) Planetary carrier, first stage
- (8) Planetary ring gear, second stage
- (9) Sun gear, second stage
- (10) Planetary carrier, second stage
- (11) Side frame mounting flange

The travel gear consists of one spur gear set and two planetary stages.

The travel gearbox is fitted to the side frame with bolts.

Function

The spur gear (Fig. 8-75, Pos. 4) is driven by a hydraulic motor connected to the input drive shaft (Fig. 8-75, Pos. 1) by means of the hollow shaft of the parking brake (Fig. 8-75, Pos. 2) .

The planetary carrier (Fig. 8-75, Pos. 7) of the first stage is driven by the sun gear (Fig. 8-75, Pos. 5) which is connected to the spur gear (Fig. 8-75, Pos. 4).

The planetary gears are revolving in the planetary ring gear (Fig. 8-75, Pos. 6) of the housing. As a result of the fixed housing, the planetary carrier (Fig. 8-75, Pos. 7) will be turned.

The planetary carrier of the first stage propels the sun gear (Fig. 8-75, Pos. 9) of the second stage. Like in the first stage, the planetary gears are revolving in a planetary ring gear (Fig. 8-75, Pos. 8) of the housing. The planetary carrier of the second stage (Fig. 8-75, Pos. 10) simultaneously acts as the sprocket drive hub.

The **ZOLLERN** parking brake is a "dry brake", no oil is permissible in the housing / on the brake disks.

Legend for Fig. 9-4:



- (47) Pressure reducing valve – track tensioning system (35 bar)
- (57Q516) Solenoid valve – travel parking brake
- (257.1) Safety relief valve (SRV) – safety valve for travel parking brake / track tensioning system (55 bar)
- (M4) Test port – travel parking brake operating pressure (35 bar)

Basic check

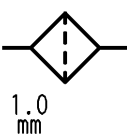
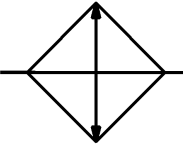

1. Connect a pressure gauge to test port M4.
2. Start the engine and let it run at high idle.
3. Ensure that the access ladder and the refilling arm are in the upper end position (as the pre-condition for releasing the travel parking brake).
4. Read the pressure (nominal value: 55 bar).
5. Stop the engine.
6. The pressure should now drop to 0 bar because solenoid valve is de-energized, allowing the oil to flow back to the tank.
7. Disconnect the pressure gauge.

NOTE: If the pressure reading differs substantially from the nominal value, the pre-set pressure reducing valve is presumably defective and should be replaced.

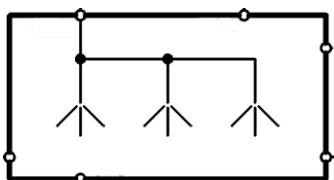
12.2.2 Components, valves

Item	Symbol	Description	Used as / at / on
15.		Accumulator, filled with nitrogen with the specified pressure for the accumulator	Input line to the remote control valves, return oil collecting tube, track tensioning system
16.		Screen filter (min screening size: 1.0 mm)	Installed in suction lines to the pumps, oil tank outlet and return oil collecting tube.
17.		Oil cooler	Hydraulic oil cooler, PTO oil cooler
18.		Breather filter	On top of PTO or hydraulic oil tank
19.		Spray nozzles, inside a case for cooling and lubrication	Gearbox (PTO) cooling and lubrication system

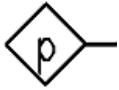
12.2.3 Sensors

Item	Symbol	Description	Used as / at / on
20.		Pressure switch / sensor Input = pressure Output = electrical signal (analogue or digital)	E.g.: return/leak oil tank (digital), high pressure filter (analogue)
21.		Pressure switch Input = pressure Output = digital	E.g.: Filter monitoring PTO lubrication









Legend for Fig. 13-3:

- (1) Phase / wire designation
- (2) Cross reference to further connection (e.g. "158.1" : continuation on page 158, column 1)
- (3) Notation of temperature switch (63B204: pre-heating reserve oil tank)
- (4) Notation of circuit breaker (12F206a: heater in cab support)
- (5) Required wire cross-section area in mm² (e.g.: 2.5 mm² = AWG 14)
- (6) Separation line for an electrical module / assembly group
- (7) Cable connector designation and pin number
- (8) Connection to a terminal block (e.g. pin 19 of terminal block 11X_51)
- (9) Contacts of relay 12K201 (Fig. 13-3, Pos. 10).
The switching contacts are always drawn at the bottom below the associated relay.
For switching contacts in usage, a cross reference is given alongside; for contacts not used, only ":" is shown.
In the example, only the switching contacts 43 and 44 are used, the contacts are shown in detail on page 69, section/column 1.
- (10) Relay coil
- (11) Notation of heating resistor (e.g.: 63E212)
- (12) Functional unit's name for the wiring diagram sector shown above
- (13) Protective earthing (PE)
- (14) Ground wire / machine ground (e.g.: 12GND)
- (15) Designation for optional design (e.g.: TT = low-temperature design)

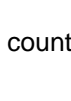
New code	Previous code	Component
32a000		HV - switch cabinet
32B802	6B2	Temperature switch at HV switch cabinet
32F701-1	0F1-1	Circuit breaker for motor 1
32F701-2	0F1-2	Circuit breaker for motor 2
32F702	0F2	HV primary circuit breaker for system transformer 1 and 2
32F703-1	0F3-1	Over voltage protection at motor 1 (discharger)
32F703-2	0F3-2	Over voltage protection at motor 2 (discharger)
32F707	0F7	Over voltage protection in high voltage (VDR-resistor)
32Q700	0Q1	Main switch
32Q701-1	0K1-1	Vacuum contactor motor 1
32Q701-2	0K1-2	Vacuum contactor motor 2
32T701-1	0T1-1	Current transformer phase 1 motor 1
32T701-2	0T1-2	Current transformer phase 1 motor 2
32T702-1	0T2-1	Current transformer phase 2 motor 1
32T702-2	0T2-2	Current transformer phase 2 motor 2
32T703-1	0T3-1	Current transformer phase 3 motor 1
32T703-2	0T3-2	Current transformer phase 3 motor 2
32T704	0T4	Voltage transformer between high voltage and low voltage
32T705	0T5	Voltage transformer between high voltage and low voltage
33a000		Low voltage in HV switch cabinet
33X003	0X3	Terminal strip in HV switch cabinet
34a000		Air condition at HV switch cabinet
34B001	3B1	Temperature switch heater at HV switch cabinet
34B001a	*B1Ta	Thermostat evaporator HV switch cabinet
34B001b	*B1Tb	Thermostat evaporator HV switch cabinet
34B001f	*B1F	Pressure switch capacitor HV switch cabinet (lower pressure limit)
34B006	2B6	Temperature switch air condition at HV switch cabinet
34B007	2B7	Dampness switch air condition at HV switch cabinet
34B011f	*B11F	Pressure switch capacitor HV switch cabinet (upper pressure limit)
34E801	2M1	Air condition compressor HV switch cabinet
34E802	*2R1	Heater air condition compressor HV switch cabinet
34F001	*A1P	Motor protection relay compressor drive HV switch cabinet
34G001	*M1G	Blower evaporator HV switch cabinet
34G021	*M21M	Blower liquefier HV switch cabinet
34G022	*M22M	Blower liquefier HV switch cabinet
34K801	2E1	Air condition HV switch cabinet
34M801	*M1V	Compressor motor HV switch cabinet
40a000		hydraulic oil tank

Symbol explanation for Fig. 14-4:

Main Gauge Screen 1 of 3

	Celsius, ambient temperature
	Engine speed
	Time
	Truck counter 1
	Truck counter 2
	Engine oil pressure
	Engine coolant temperature
	Hydraulic oil temperature
	Fuel level

Error Code (Message Code) G = Shovel C = Engine	Colour Code of Top Message 0 = RED 1 = YELLOW 2 = GREEN	Instruction Message No.	Display	Acoustic Signal	Memory	G-Code
G00064	0	2	1		1	Trouble monitoring hydraulic oil level
G00065	1	2	1		1	Very low hydraulic oil level
G00066	0	2	2		1	Trouble hydraulic oil temperature
G00067	1	2	1		1	Trouble battery voltage too high
G00069	1	2	1		1	Trouble monitoring oil temperature gear (PTO 1)
G00070	1	2	2	Y	1	Trouble oil temperature gear (PTO 1)
G00071	1	2	2	Y	1	Trouble gear lubrication (PTO 1)
G00072			N		2	Trouble monitoring hydraulic oil level
G00073			N		2	Trouble monitoring remote engine oil level 1
G00074			N		2	Trouble monitoring grease pressure (central)
G00075			N		2	Trouble monitoring grease pressure (slew ring gear)
G00076			N		2	Trouble monitoring pressure suction tank
G00077			N		2	Trouble monitoring grease level (central)
G00078			N		2	Trouble monitoring grease level (slew ring gear)
G00079			N		2	Trouble monitoring pressure oil cooler 1
G00080			N		2	Trouble monitoring pressure preload valve
G00081	0	2	2		1	Trouble lubrication system
G00086	2	12	2	Y	3	SHUTDOWN
G00087	2		2	Y	3	Stop all movements for low idle
G00089	1	2	2		3	EBL bypassed
G00090	0	8	2	Y	1	Trouble power supply
G00091	0	9	2		3	Pilot control cut out

14.3 FLOW CHARTS (1-4) VHMS MAIN SCREENS

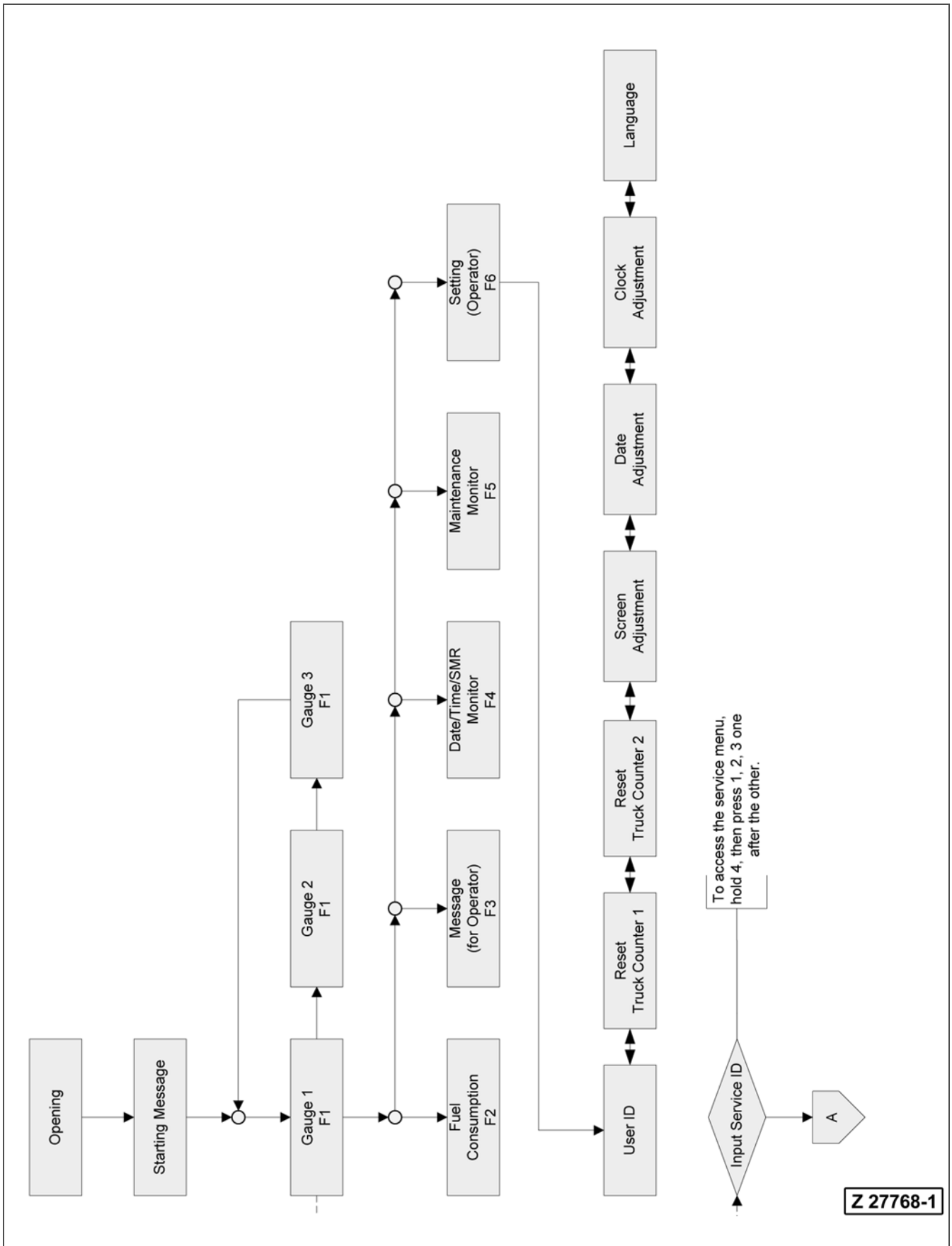

Fig. 14-22 Main screen flow chart for the Operator Level (1 of 1)

14.4.4.2 POWER CHECK

The *POWER CHECK* screens should assist you if you want to check or identify:

- (a) engine performance/engine output power
- (b) pressure adjustment/hydraulic system problems

There are 3 screens *POWER CHECK* for freezing data under different conditions.

NOTE: In order to obtain a complete *POWER CHECK*, the **F6** button should only be pressed after the 3rd screen (Fig. 14-124) "POWER CHECK 3/3" has been frozen.

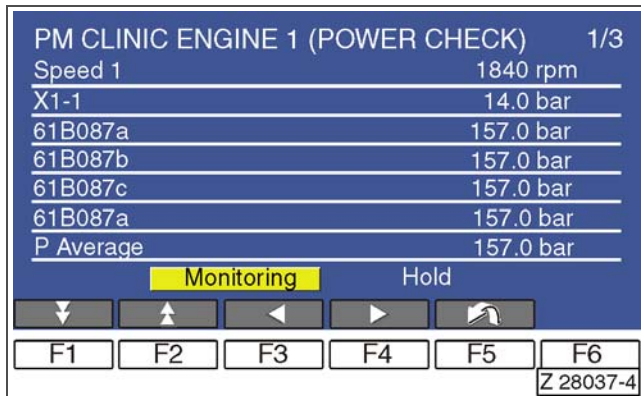

Fig. 14-123 PM-CLINIC - POWER CHECK 1/3

It is possible to store the values of 3 different *POWER CHECKS* in the screens 1/3, 2/3, and 3/3. Press button **F1** or **F2** to monitor the *POWER CHECK* data of all 3 screens.

If you want to freeze the data, press button **F4** to move the yellow mark to *Hold* at the bottom of the display (Fig. 14-124). If *Hold* is highlighted yellow, press button **F4** to freeze the current *PM-CLINIC* data.

To show the current data again, press button **F3**. The yellow mark moves to *Monitoring* again (Fig. 14-123).

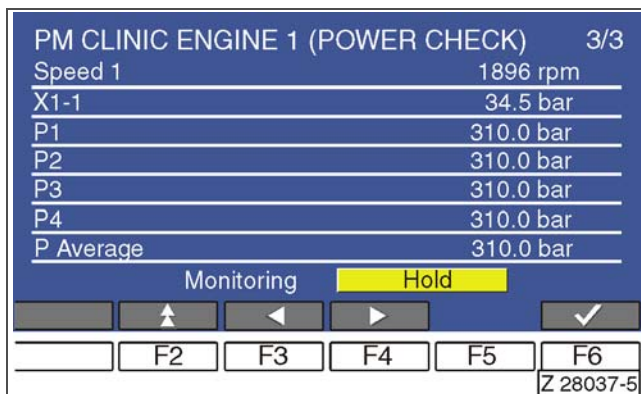

Fig. 14-124 PM-CLINIC - POWER CHECK 3/3

After pressing button **F6** in screen *POWER CHECK* 3/3 (Fig. 14-124) the following screen appears:

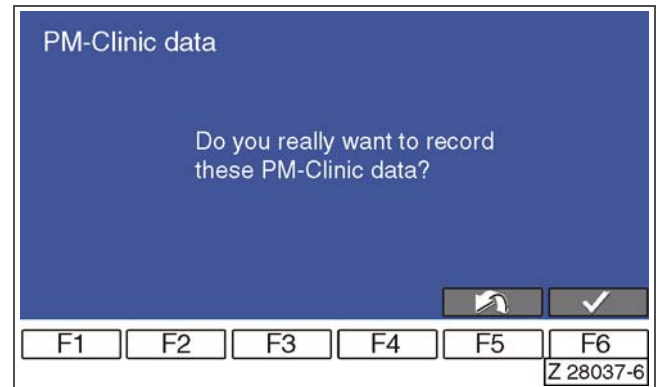

Fig. 14-125 Record PM-Clinic data - Yes/No

Press button **F6** if you want to record the data.

Press button **F5** for exit if you don't want to record the data. The system returns to the *POWER CHECK* screen

14.7.1.3 MTC-FIRMWARE AND SOFTWARE

The MTC is programmed with *Firmware* and *Software*.

FIRMWARE

The *Firmware* internally operates and manages the MTC unit, independent of the kind of the machine.

SOFTWARE

The *Software* is a machine-specific application which manages the excavator's control system. Therefore it is essential that the *Software* version and the machine model properly fit together.

It is possible to replace the programs (*Firmware* and *Software*) of the MTC. For such a procedure a specific version of the *CoDeSys* software must be installed on the used laptop.

Via LAN connection such a software upload can be done comfortably.

The *CoDeSys* software can also be used as a *Visualization*, which is an important tool for troubleshooting. For more details of the *CoDeSys Visualization* refer to the *Visualization User Manual* and to the *Troubleshooting Manual* of your machine.

For the details of the:

- MTC *Firmware* & *Software*
- *CoDeSys* software
- *Visualization*
- Appropriate equipment
- Communication procedures with the MTC

refer to the Troubleshooting Manual of your machine.

CAUTION

Before trying to change any software of the MTC, always make sure that:

- the complete required equipment is present
- the correct software packages are present
- a qualified service technician will perform the procedure

Otherwise a complete shutdown of the machine may result.

Legend for Fig. 15-2:

- (1) Drive of lubrication pump (hydraulically)
- (2) Flow control valve (19-21 double strokes/min)
- (3) Pressure relief valve (max. 45 bar)
- (4) Grease pump control solenoid valve (62Q507 / 62Q509) - (pump on / off)
- (5) Hydraulic oil return line
- (6) Hydraulic oil supply line (60+3 bar X4-pressure)
- (7) Lubricant pressure gauge
- (8) Lubricant in-line filter
- (9) Lubricant pressure release solenoid valve (62Q507a / 62Q509a)
- (10) Lubricant supply line from pump to injector
- (11) Lubricant release line
- (12) End-line-pressure switch (80B043 / 62B046)
- (13) Lubricant injector
- (14) Lubricant feed line from injector to the lubrication point (bearings or open gear of the swing ring teeth)
- (15) Lubricant pump
- (16a) Bearing
- (16b) Dummy wheel
- (17) Lubricant
- (18) Lubricant container
- (19) Breather filter for lubricant container
- (20) Sonar sensor for lubricant level indication (62B108 / 62B109)

15.7.5 CONNECTION OF ONE OR MORE INJECTORS

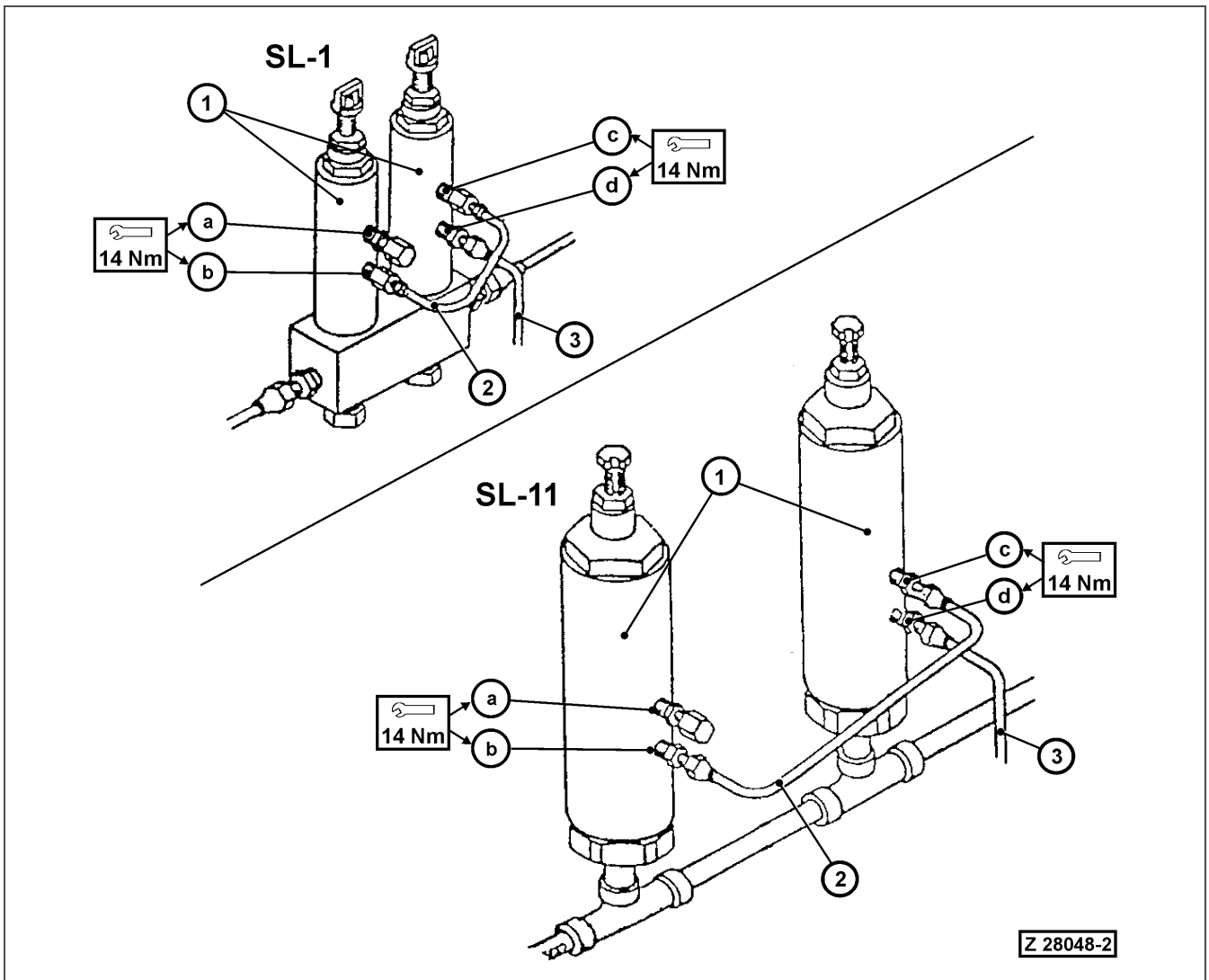

Fig. 15-12 Connection of lubricant injectors

Description

To increase the lubricant output volume, the injectors (1) are designed to be combined (2 or more injectors).

A connector pipe (2) is used to connect two injectors (1). Lubricant from the first injector, outlet (b), is directed through the connector pipe (2) to the inlet (c) of the second injector. Both injectors are now connected, in order to lubricate one lubrication point via pipe (3).

This connection is possible for both injector types (SL-1 and SL-11).

⚠ CAUTION

When installing a fitting to an injector, always observe the maximum tightening torque of 14 Nm. Otherwise the fitting will be screwed too far into the injector and the injector piston movement will be blocked. As a result the grease supply will fail.

For the tightening procedure also refer to the PARTS & SERVICE NEWS AH10532 (latest edition).

NOTE: In case of leakage use thread tape (Teflon®) or Loctite® when installing a fitting to any injector.

TABLE OF CONTENTS

1 SAFETY	1-1
1.1 SAFETY INFORMATION	1-2
1.2 OVERVIEW	1-3
1.2.1 NORMAL OPERATIONS	1-3
1.2.2 REGULAR MAINTENANCE	1-3
1.2.3 TROUBLESHOOTING, ADJUSTMENTS AND REPAIR	1-3
1.2.4 ADDITIONAL SAFETY PRECAUTIONS FOR ASSEMBLING, DISASSEMBLING AND TRANSPORTATION OF THE EXCAVATOR.....	1-3
1.3 SOUND PRESSURE LEVEL IN THE OPERATOR'S CAB	1-4
1.4 GENERAL PRECAUTIONS COMMON TO OPERATION ON THE EXCAVATOR	1-5
1.4.1 UNDERSTANDING THE MACHINE	1-5
1.4.2 PRECAUTIONS BEFORE STARTING OPERATION ON THE EXCAVATOR	1-5
1.4.2.1 ENSURING SAFE OPERATION.....	1-5
1.4.3 PREPARATIONS FOR SAFE OPERATION.....	1-5
1.4.3.1 PRECAUTIONS REGARDING SAFETY RELATED EQUIPMENT	1-5
1.4.3.2 INSPECTING THE MACHINE	1-5
1.4.3.3 WEAR WELL FITTING CLOTHES AND PROTECTIVE EQUIPMENT.....	1-6
1.4.3.4 KEEP MACHINE CLEAN	1-6
1.4.3.5 PRECAUTIONS INSIDE OPERATOR'S COMPARTMENT.....	1-6
1.4.3.6 PROVIDE FIRE EXTINGUISHER AND FIRST AID KIT	1-7
1.4.3.7 IF A PROBLEM IS FOUND	1-7
1.4.4 FIRE PREVENTION	1-7
1.4.4.1 PRECAUTIONS TO PREVENT FIRE	1-7
1.4.4.2 ACTION IF FIRE OCCURS.....	1-8
1.4.4.3 EMERGENCY EXIT FROM OPERATOR'S CAB.....	1-9
1.4.5 PRECAUTIONS WHEN GETTING ON OR OFF THE MACHINE	1-9
1.4.5.1 USE HANDRAILS AND STEPS WHEN GETTING ON OR OFF THE MACHINE .	1-9
1.4.5.2 NO JUMPING ON OR OFF THE MACHINE	1-9
1.4.5.3 NO PEOPLE ON THE ATTACHMENT	1-9
1.4.5.4 WORKING IN HIGH PLACES.....	1-9
1.4.5.5 LEAVING OPERATOR'S SEAT WITH LOCK.....	1-10
1.4.5.6 LEAVING THE MACHINE	1-10
1.4.6 BURN PREVENTION	1-11
1.4.6.1 HOT COOLANT	1-11
1.4.6.2 HOT OIL	1-11
1.4.7 PRECAUTIONS WHEN CLEANING CAB GLASS	1-11
1.4.8 PRECAUTIONS RELATED TO PROTECTIVE STRUCTURES.....	1-12
1.4.8.1 UNAUTHORIZED MODIFICATION	1-12
1.4.8.2 PRECAUTIONS RELATED TO ATTACHMENTS AND OPTIONS.....	1-12
1.4.9 PRECAUTIONS AT JOBSITE	1-13
1.4.9.1 VISIBILITY FROM OPERATOR'S SEAT	1-14
1.4.9.2 CAMERA SYSTEM WITH MONITORS	1-14
1.4.9.3 ENSURE GOOD VISIBILITY	1-14
1.4.9.4 CHECKING SIGNS AND SIGNALMAN'S SIGNALS	1-14
1.4.9.5 INVESTIGATE AND CONFIRM JOBSITE CONDITIONS	1-15
1.4.9.6 DO NOT GO CLOSE TO HIGH VOLTAGE CABLES	1-15
1.4.9.7 WORKING ON LOOSE GROUND	1-16

1.4.6 BURN PREVENTION

1.4.6.1 HOT COOLANT

Refer to Fig. 1-11:

- To prevent burns from hot water or steam spurting out when checking or draining the coolant, wait for the water to cool to a temperature where it is possible to touch the radiator cap (Fig. 1-12) by hand before starting the operation. Even when the coolant has cooled down, loosen the cap slowly to relieve the pressure inside the radiator before removing the cap.

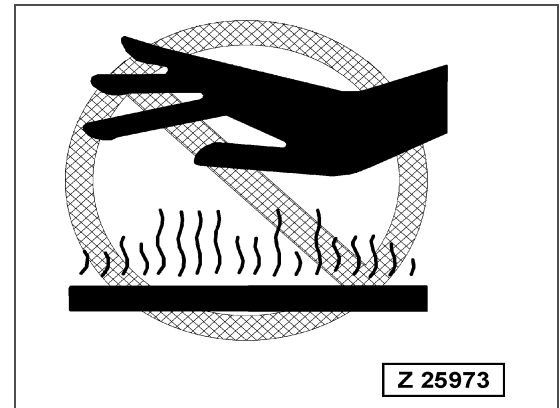

Fig. 1-11

1.4.6.2 HOT OIL

Refer to Fig. 1-12:

- To prevent burns from hot oil spurting out when checking or draining the oil, wait for the oil to cool to a temperature where it is possible to touch the cap or plug by hand before starting the operation. Even when the oil has cooled down, loosen the cap or plug slowly to relieve the internal pressure before removing the cap or plug.

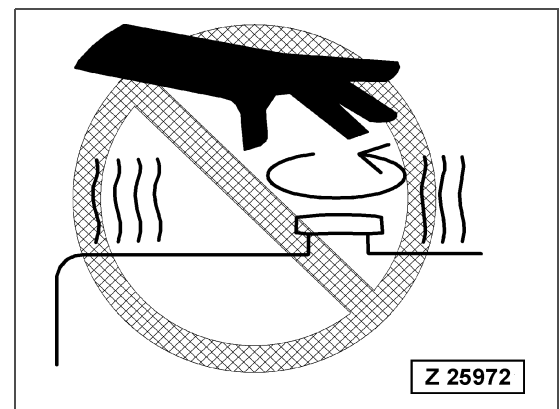

Fig. 1-12

1.4.7 PRECAUTIONS WHEN CLEANING CAB GLASS

Always keep the cab glass clean to ensure good visibility when operating.

Use an ethyl alcohol based washer liquid. Methyl alcohol based liquid may irritate your eyes, so do not use it.

If the cab glass on the work equipment side is broken, there is a hazard that the intruding objects may contact the operator's body directly. Stop operation immediately and replace the glass.

1.5.3.2 HANDLING HIGH PRESSURES HOSES OR PIPES

- If oil or fuel leaks from high-pressure hoses, it may cause fire or defective operation, which may lead to serious injury. If any loose bolts are found, stop work and tighten to the specified torque. If any damaged hoses are found, stop operations immediately and contact your Komatsu distributor.

Replace the hose if any of the following problems are found.

- Damaged or leaking hydraulic fitting.
- Frayed or cut covering or exposed reinforcement wire layer.
- Covering swollen in places.
- Twisted or crushed movable portion.
- Foreign material embedded in covering.

1.5.3.3 REPLACEMENT OF HOSE LINES

Hydraulic hoses are subjected to natural aging. Hence, their usable lifetime is limited to maximum 6 years.

NOTICE

The maximum permissible storage time of hydraulic hoses must be observed.

- This storage period is part of the usable lifetime and must be considered when installing a new hose line. If, for example, a hose line with a one year storage time is to be installed, the remaining service life of the hose line must be considered. All hose lines are marked with the date of production.
- Hose lines considered as Safety Critical Parts have to be replaced earlier. Refer to the chapter "Lubrication and Maintenance Schedule" in the MAINTENANCE section of the Operation and Maintenance Manual for further information.

All hydraulic hoses of the Shovel have to be replaced when their service life has expired, even if there is no visible damage. Refer to the chapter "Lubrication and Maintenance Schedule" in the MAINTENANCE section of the Operation and Maintenance Manual for further information.

NOTICE

Repairs on hydraulic hoses are not allowed. Use ONLY GENUINE Komatsu Mining Germany replacement hose lines.

1.5.3.4 INSPECTION OF HOSE LINES

WARNING

FLUID UNDER HIGH PRESSURE!

The hydraulic system is always under internal pressure and can lead to serious injury when leaking. When inspecting or replacing piping or hoses, always check that the pressure in the hydraulic circuit has been released.

Inspect all hoses, hose lines and fittings carefully during the course of the daily walk-around inspection. Check for leaks and damages. Beware of pinhole leakages. Replace damaged parts without delay.

2.8 SEQUENCE OF EVENTS IN TROUBLESHOOTING

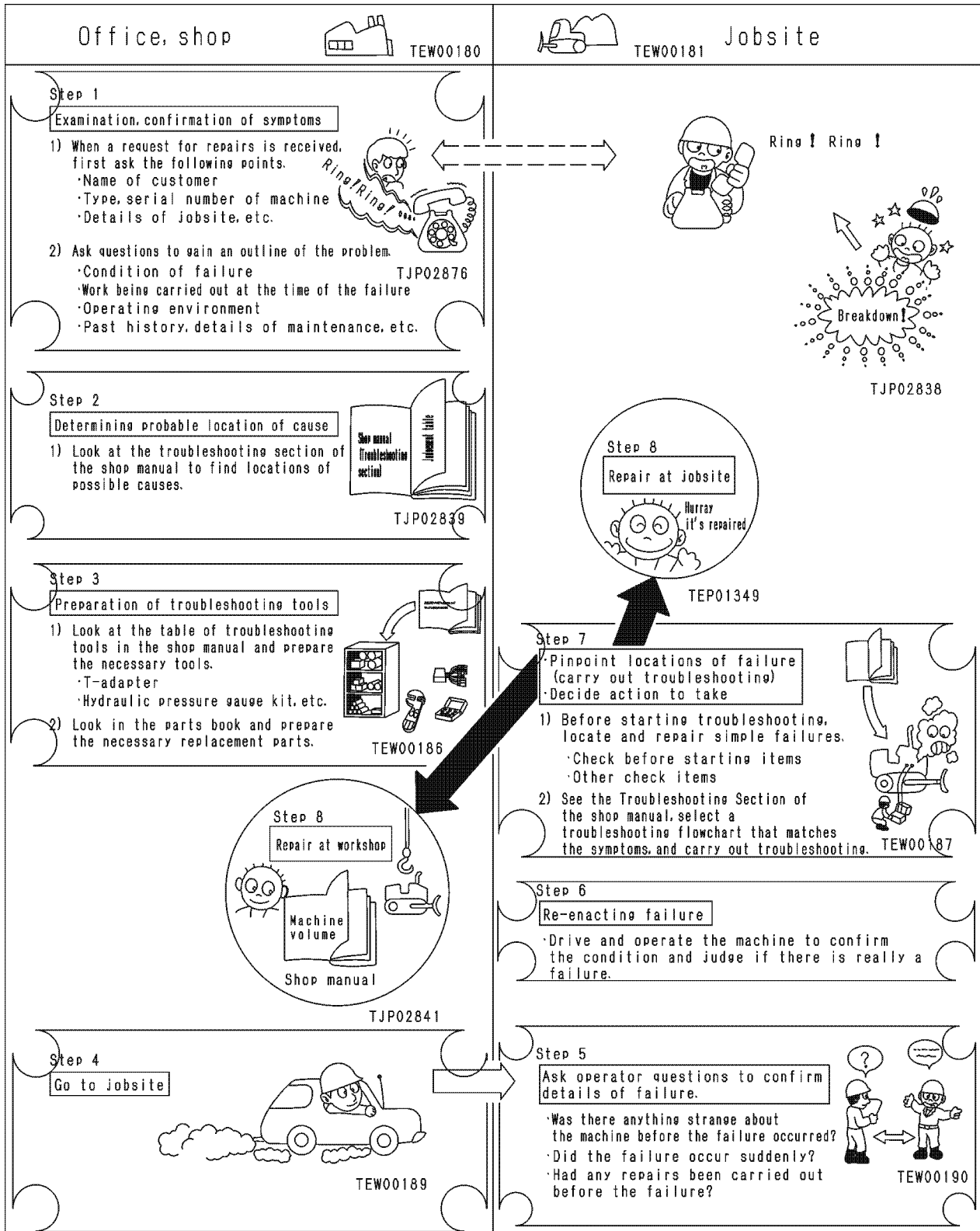

Z 26981

Fig. 2-2 Sequence Of Events In Troubleshooting

Legend for Fig. 3-1 - View onto the Superstructure

- (1) Hydraulically operated access ladder
- (2) Battery main switches (batteries G1-G4)
- (2a) Battery main switches (batteries G8-G9)
- (3) Lift cylinder for access ladder
- (4) Batteries, location below the catwalk (batteries G1-G4)
- (5) Control switch for access ladder
- (6) Emergency engine shut down switch
- (7) Fuel tank
- (8) Cab base, contains the electronic components of the VHMS system, the electrical switch boards, and the batteries G8 & G9
- (9) Side window of operator's cab
- (10) Swing circle guard
- (11) Emergency escape ladder
- (12) Engine air cleaners
- (13) Exhaust mufflers
- (14) Air duct
- (15) Extinguishing agent tank assemblies, only on machines equipped with a fire detection, actuation and suppression system
- (16) Counterweight
- (17) Main control valves & remote control valves with high pressure in-line filters
- (18) Hydraulic oil reservoir
- (19) Return oil filters and leak oil filter
- (20) Hydraulic oil cooler
- (21) Swing machinery
- (22) Distributor manifold
- (23) Swing circle pinion Lubrication System (SLS)
- (24) Central Lubrication System (CLS)
- (25) Node box, location 40
- (26) Node box, location 51
- (27) Node box, location 56

4 STANDARD VALUE TABLE FOR ELECTRICAL COMPONENTS

G00108 - Trouble slew parking brake control Output to 56K250a

G00110 - Trouble slew parking brake control Output to 56K250b

[1/4]

Trouble code	Trouble	G00108 - Trouble slew parking brake control Output to 56K250a G00110 - Trouble slew parking brake control Output to 56K250b
G00108 & G00110		
Contents of trouble	<ul style="list-style-type: none"> - This message is displayed if the wiring between node output and solenoid (via relay 56K250a) is interrupted (output check). - The troubleshooting procedure for the redundant relay 56K250b is analogously. 	
Related information	<ul style="list-style-type: none"> - This is a control function for the connection between node output and solenoid. - Also check for G00043. If trouble message G00043 is displayed (short circuit at the node output) follow the troubleshooting procedure for G00043 first. - If the connection between node output and solenoid is faulty, the function (slew parking brake) is no longer available. 	
Action of controller	<ul style="list-style-type: none"> - Background colour of the trouble code information: yellow - Acoustic signal (20P022) in the cab ON. <p>REMARKS: G00108/G00110 is only displayed once during one "Key switch ON" period.</p>	
Problem that appears on the machine	The function (slew parking brake) is not available.	
Instruction message	2	Inform service.

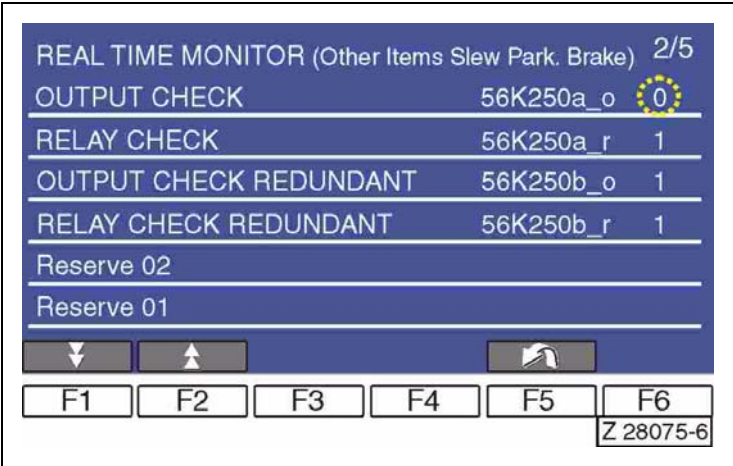
Possible cause	Step	Test condition & Inspection	Procedure	Nominal value
The node output signal via relay to the solenoid is disturbed G00108 → 56K250a G00110 → 56K250b	1	▶ Main key switch 20S001 ON & 20S029 in position 0	Refer to the Wiring Diagram and check the wiring between node output and solenoid. Repair the wiring between node output and solenoid (via relay) as necessary.	
		▶ REAL TIME MONITOR - Output check		
Continue trouble-shooting of step 1 (cross check)	1	<ol style="list-style-type: none"> 1. Main key switch 20S001 ON. 2. Engine OFF. 3. REAL TIME MONITOR → 14 Other items → Screen 2/5 4. Switch 20S029 in position 0. 5. Verify the <i>Output Check</i> on the REAL TIME MONITOR. 		
		Digit "0" in line OUTPUT CHECK for 56K250a confirms the trouble message.		

Location	Component Code	Condition at Activation	Node	VHMS Display Text	REAL TIME MONITOR	Screen No.
57	57K553-1	24V	56K316	Gear oil cooler back-pressure	Output signals Control panel	16/24
	57K506a-1	24V	56K316	Valve fan drive 1 min.	Output signals Control panel	16/24
	57K506b-1	24V	56K316	Valve fan drive 1 med.	Output signals Control panel	16/24
	57K646	24V	56K315	Pump control	Output signals Control panel	15/24
	57K647	24V	56K316	Pump control	Output signals Control panel	15/24
	57K648	24V	56K316	Pump control	Output signals Control panel	15/24
	57K626	24V	56K315	Pump control	Output signals Control panel	14/24
	57K630	24V	56K315	Pump control	Output signals Control panel	14/24
	57K631	24V	56K315	Pump control	Output signals Control panel	15/24
	57K517	24V	56K316	Pump control	Output signals Control panel	14/24
	57K517a	24V	56K316	Pump control	Output signals Control panel	14/24
	57Q624c	24V	56K315	Service arm enable	Output signals Service arm	19/24
	57Q625	24V	56K315	Ladder movement fast	Output signals Ladder	21/24
60	60P140	24V	51K318	Travel motion horn	Output signals Superstructure	24/24
61	61Q632a	24V	40K313	Auto float stick	Output signals Ext. low volt.	5/24
	61Q633a	24V	40K313	Auto float stick	Output signals Ext. low volt.	5/24
	61Q635a	24V	40K313	Auto float boom	Output signals Ext. low volt.	5/24
62	62Q507	24V	40K313	CLS 1 Lubrication pump	Output signals Lubric. Syst.	23/24
	62Q507a	24V	40K313	CLS 1 Release lubrication line	Output signals Lubric. Syst.	23/24
	62Q509	24V	11K303	SLS Lubrication pump	Output signals Lubric. Syst.	23/24
	62Q509a	24V	11K303	SLS Release lubrication line	Output signals Lubric. Syst.	23/24
	test_leve			Test power supply for lever	Output signals Ext. low volt.	8/24

6.8 POWER SUPPLY

Circuit	Electric Appliance
11F013	Binary sensors
11F013a	Analog sensors

Wiring Diagram (junction box) for trouble codes G0012 & G0013

[6/6]

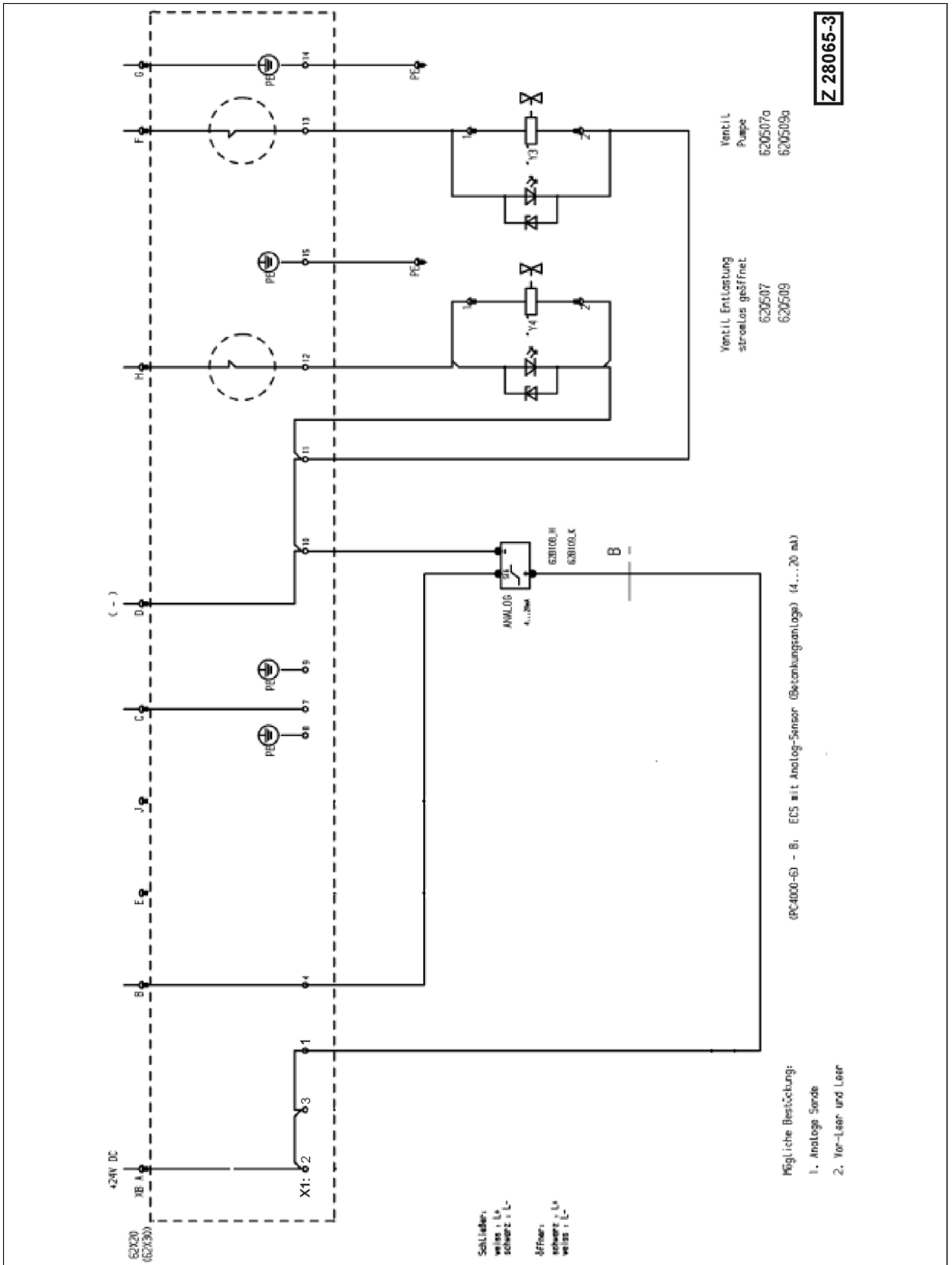

Fig. 7-9 Wiring Diagram (junction box) for trouble codes G0012 & G0013

Input signal (analog) of relay 11K032 on the REAL TIME MONITOR (G00054)

[3/3]

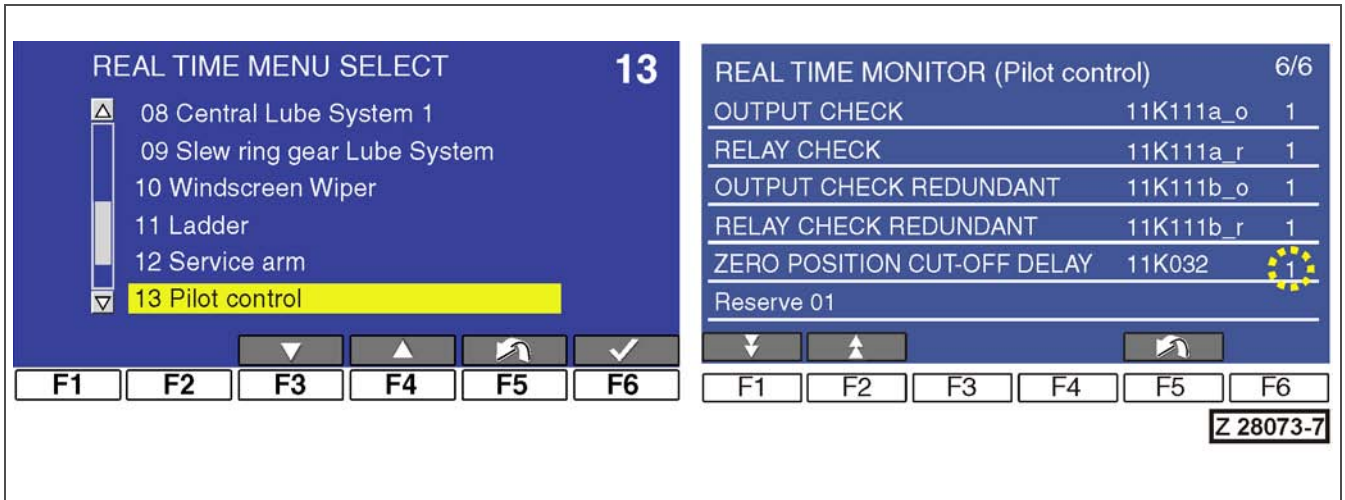

Fig. 7-24 G00054 - Input signal (analog) of relay 11K032 on the REAL TIME MONITOR

Exemplary view onto the VHMS Failure History (G00054)

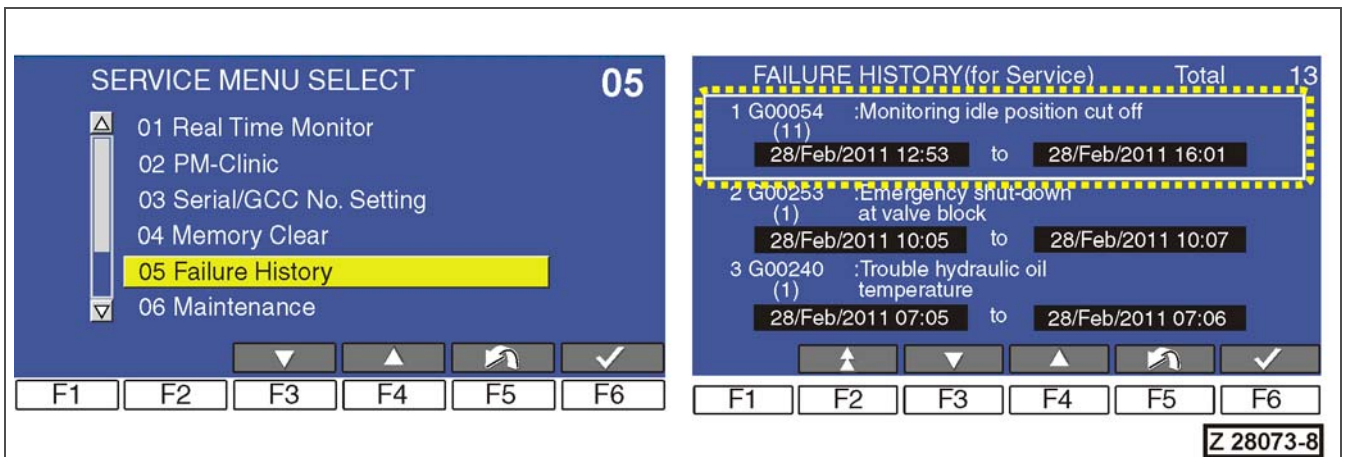

Fig. 7-25 G00054 - Exemplary view onto the VHMS Failure History

G00070 - Trouble oil temperature gear (PTO 1)

[1/3]

Trouble code	Trouble	Trouble oil temperature gear (PTO 1)																																
G00070																																		
Contents of trouble	- The PTO gear oil temperature sensor 57B049-1 (PT100 type) signals overheating. - The system assumes that the gear oil temperature sensor 57B049-1 or the wiring circuit of the monitoring system is not defective.																																	
Related information	PTO gear oil temperature for 5 seconds > TG2 For the definition of the PTO gear oil temperatures refer to the following table: <table border="1" style="margin: 10px auto; border-collapse: collapse;"> <tr> <td colspan="3" style="text-align: center;">Temperatur Getriebeöl (TG)</td> <td style="text-align: right; border: 1px solid black;">Z 26718</td> </tr> <tr> <td colspan="4" style="text-align: center;">temperature gear oil (TG)</td> </tr> <tr> <td colspan="4" style="text-align: center;">Ölart nach ISO</td> </tr> <tr> <td colspan="4" style="text-align: center;">kind of oil according to ISO</td> </tr> <tr> <td style="text-align: center;">temperature in C</td> <td style="text-align: center;">T32</td> <td style="text-align: center;">CLP150</td> <td style="text-align: center;">Hypoid Oil 75W-140</td> </tr> <tr> <td style="text-align: center;">TypNr. / type no.</td> <td style="text-align: center;">1</td> <td style="text-align: center;">2</td> <td style="text-align: center;">3</td> </tr> <tr> <td style="text-align: center;">TG2</td> <td style="text-align: center;">60</td> <td style="text-align: center;">95</td> <td style="text-align: center;">95</td> </tr> <tr> <td style="text-align: center;">TG1</td> <td style="text-align: center;">15</td> <td style="text-align: center;">48</td> <td style="text-align: center;">54</td> </tr> </table>		Temperatur Getriebeöl (TG)			Z 26718	temperature gear oil (TG)				Ölart nach ISO				kind of oil according to ISO				temperature in C	T32	CLP150	Hypoid Oil 75W-140	TypNr. / type no.	1	2	3	TG2	60	95	95	TG1	15	48	54
Temperatur Getriebeöl (TG)			Z 26718																															
temperature gear oil (TG)																																		
Ölart nach ISO																																		
kind of oil according to ISO																																		
temperature in C	T32	CLP150	Hypoid Oil 75W-140																															
TypNr. / type no.	1	2	3																															
TG2	60	95	95																															
TG1	15	48	54																															
Action of controller	- Background colour of the trouble code information: yellow - The MTC blinks out the binary code 001101																																	
Problem that appears on the machine	The PTO gear oil is overheated.																																	
Instruction message	2	Inform service.																																

Possible cause	Step	Test condition & Inspection	Procedure	Nominal value
PTO gear oil overheated	1	▶ Engine running at high idle, with max. fan speed. Using a laser temperature meter, verify if the PTO gear oil temperature at the temperature sensor 57B049-1 is too high. For the location of 57B049-1 refer to Fig. 7-42 on page 7-73 . For the definition of the PTO gear oil temperatures refer to the above table (Z 26718).	Go to next step.	
		▶ Check with stopped engine and the attachment in its defined position. Check the PTO gear oil level with the dipstick as described in the OPERATION & MAINTENANCE MANUAL, section <i>Every 50 Operating Hours or Weekly</i> . Is the PTO gear oil level within the specified range?	Yes: Go to next step. No: Refill or drain PTO gear oil until the target level is reached. Then monitor the PTO gear oil temperature again.	OM/M
Wrong PTO gear oil settings may cause the problem	3	▶ Main key switch 20S001 ON. Check the PTO gear oil settings (oil type and viscosity) on the service level of the VHMS system. Are the oil settings correct?	Yes: Go to next step. No: Adjust the PTO gear oil settings on the service level of the VHMS system. Then verify that the gear oil temperature is in normal range.	

G00103 - Faulty switch 20M004 [S/N 08199 only]

[2/4]

Possible cause	Step	Test condition & Inspection	Procedure	Nominal value
The limit switch system is disturbed	3	<p>► Main key switch 20S001 OFF.</p> <p>Refer to the Wiring Diagram. Check the wiring between the wiper motor, pin 2, and node 9, connector 3, pin 2 for continuity. Is continuity present?</p>	<p>Yes Go to next step.</p>	
			<p>No Locate the problem and repair as necessary. If any problem was found and repaired, recheck the wiper system for proper function. If OK, go to step 6. If no problem was found, go to next step.</p>	
The wiper motor 20M004 is defective	4	<p>► Main key switch 20S001 OFF. Wiper switched OFF (20S011 in position "0")</p> <p>Replace the wiper motor 20M004. During the installation of the wiper motor follow the adjustment procedures in the PARTS & SERVICE NEWS AH06533 (latest version) and and make sure, that the basic adjustment of the wiper linkage is made properly. After that, recheck the wiper system for proper function. Do the wipers operate without any problem?</p>	<p>Yes Go to step 6.</p>	
			<p>No Refer to the Wiring Diagram. Check the relating circuits and the electrical components. After that, verify that the wiper function is free of problems.</p>	
Malfunction in the wiring circuit of the wiper system	5	<p>Refer to the Wiring Diagram. Check the relating circuits and the electrical components, locate the problem, and repair or replace defective components as necessary. After that, verify that the wipers are working properly.</p>	Go to next step.	
Final check	6	<p>Bring the machine back into the original condition. Start the machine and verify that the trouble code does not arise again.</p>		

G00141 - Trouble monitoring X2 pressure

[2/3]

Possible cause	Step	Test condition & Inspection	Procedure	Nominal value	
Defective X2 pressure sensor 57B086 (internal malfunction)	5	<ul style="list-style-type: none"> ▶ Prepare with main key switch 20S001 OFF. Then carry out troubleshooting with main key switch ON. 			
		Disconnect the connector from the X2 pressure sensor and insert the Deutsch T-box.	Yes	Go to next step.	V_{signal} 0.5 - 9.5V
		Measure the signal voltage at the sensor terminals B and C. Do the measurements meet the specification?	No	Replace the X2 pressure sensor and verify that the repair was successful.	
Disconnection in the signal wiring between X2 pressure sensor and node 14, connector 2, pin 4 (disconnection or defective contact in any connector).	6	<ul style="list-style-type: none"> ▶ Main key switch 20S001 OFF. 			
		Check for continuity in the signal wiring between sensor terminal B and node 14.		If the resistance is too high, refer to the Wiring Diagram and locate the problem in the signal wiring of the X2 pressure sensor. Repair as necessary. After successful repair go to final step 7.	R_{max} 1Ω
Final check	7	Bring the machine back into the original condition. Start the machine and verify that the trouble code does not arise again.			

G00161 - Trouble monitoring battery voltage

[2/3]

Possible cause	Step	Test condition & Inspection	Procedure	Nominal value	
The signal voltage of resistor 11T080 to node 2, connector 2, terminal 8 is not correct or not present	5	▶ Main key switch 20S001 ON.			
		Disconnect the node connector 2 and measure the signal voltage at terminal 8. Does the signal voltage meet the specification?	Yes	Go to step 7.	V _{Signal min.} 12V
			No	Go to next step.	V _{Signal max.} 39V
Resistor 11T080 is defective	6	▶ Main key switch 20S001 OFF.			
		Measure the resistance of both internal resistors in 11T080. Does the resistance correspond to the nominal values?	Yes	Go to next step.	11T080 30.1kΩ+ 10.0kΩ
			No	Replace the defective resistor(s) and recheck the system for proper function.	
Disconnection in the signal wire between resistor 11T080 and node 2, connector 2, terminal 8 (disconnection or defective contact)	7	▶ Main key switch 20S001 OFF.			
		Check the signal wire between resistor 11T080 and node 2, connector 2, terminal 8 for continuity. Is continuity present?	Yes	Go to next step.	R _{max} 1Ω
			No	Disconnection or short circuit in the signal wire (including connections) between resistor 11T080 and node 2, connector 2, terminal 8. Locate the problem and repair as necessary.	
Final check	8	Bring the machine back into the original condition. Start the machine and verify that the trouble code does not arise again.			

G00181 - Trouble pilot pressure X2 too high

[1/2]

Trouble code	Trouble	Trouble pilot pressure X2 too high
G00181		
Contents of trouble	- The message is displayed if the pilot pressure X2 is too high. - The system assumes that the monitoring circuit for the X2 pressure is not disturbed.	
Related information	The pressure sensor 57B086 detected a pressure of more than 52 bar during 2 seconds.	
Action of controller	Background colour of the trouble code information: yellow	
Problem that appears on the machine	A too high X2 pressure affects the hydraulic system adversely.	
Instruction message	17	Inform service till end of shift and then press cancel button.

Possible cause	Step	Test condition & Inspection	Procedure	Nominal value	
The X2 pressure is too high	1	▶ Engine running at high idle & operation temperature.		Temp hydr.oil ≥60°C	
		Connect a pressure gauge (0-60 bar) to the pressure test port M1.2 at the valve cartridge block. Measure the pilot pressure X2. Is the X2 pressure too high (above 52 bar)?	Yes	Go to next step.	X2 pressure 45±2bar
			No	Replace the pressure sensor 57B086. Verify that trouble code G00181 is not set again. If the repair was successful, go to final step 3.	
Wrong X2 pressure adjustment	2	Refer to the SERVICE MANUAL, section CHECKS AND ADJUSTMENT OF PILOT PRESSURE and follow the adjustment procedures for the X2 pressure.	After successful adjustment go to final step 3.		
Final check	3	Bring the machine back into the original condition. Start the machine and verify that the trouble code does not arise again.			

CLICK HERE TO **DOWNLOAD** THE COMPLETE MANUAL

- Thank you very much for reading the preview of the manual.
- You can download the complete manual from: www.heydownloads.com by clicking the link below



- Please note: If there is no response to CLICKING the link, please download this PDF first and then click on it.

CLICK HERE TO **DOWNLOAD** THE COMPLETE MANUAL

G00314 - Trouble ladder down Output to 56K254a
G00316 - Trouble ladder down redundant Output to 56K254b

[1/1]

Trouble code	Trouble	G00314 - Trouble ladder down Output to 56K254a G00316 - Trouble ladder down redundant Output to 56K254b
G00314 & G00316		
Contents of trouble	<ul style="list-style-type: none"> - This message is displayed if the wiring between node output and solenoid (via relay 56K254a) is interrupted (output check). - The troubleshooting procedure for the redundant relay 56K254b is analogously. 	
Related information	<ul style="list-style-type: none"> - This is a control function for the connection between node output and solenoid. - Also check for G00043. If trouble message G00043 is displayed (short circuit at the node output) follow the troubleshooting procedure for G00043 first. - If the connection between node output and solenoid is faulty, the function (ladder down) is no longer available. 	
Action of controller	<ul style="list-style-type: none"> - Background colour of the trouble code information: yellow - Acoustic signal (20P022) in the cab ON. <p>REMARKS: G00314/G00316 is only displayed once during one "Key switch ON" period.</p>	
Problem that appears on the machine	The function (ladder down) is not available.	
Instruction message	2	Inform service.

- Use the troubleshooting chart of G00108/G00110 as a guideline for troubleshooting of *Output Check* for G00314/G00316, [refer to section 5.3.2 on page 5-12](#).
- Refer to the Wiring Diagram and check for 56K254a/56K254b.
- Use the REAL TIME MONITOR
 - 11 Ladder
 - Sub-screen 3/5

SEL010 - Oil is in engine coolant

[2/2]

Judgment Table for SEL010

		Causes			
		Broken cylinder head or head gasket	Insufficient protrusion of cylinder liner	Broken liner O-ring, holes caused by pitting	Internal cracks in the cylinder block
Questions	Confirm the recent repair history				
	Degree of use of the machine			◊	
	Oil level				
	Suddenly increased	○			
	Gradually increased			○	○
Check items	Hard water is being used as engine coolant			○	
	Engine oil level has risen, oil is cloudy white			○	○
	Excessive air bubbles inside radiator, coolant sputters out	■	■		
Troubleshooting	Pressure-tightness test of cylinder head shows, there is a leakage	●			
	Remove cylinder head and inspect directly		●		
	Remove oil pan and inspect directly			●	●
Remedy		Replace	Replace	Replace	Replace

SHY014 - Ladder does not move, or slow movement

[1/2]

Trouble code	Trouble	Ladder does not move, or slow movement
SHY014		
Contents of trouble	- The ladder does not move when the function "ladder up" or "ladder down" is requested, or the ladder movement is too slow.	
Related information	- The electrical function of this circuit is already tested and ok. - The ladder pressure supply is charged by X2 pressure. - A 70 bar SRV is mounted in the ladder circuit.	
Problem that appears on the machine	The ladder does not move when the function "ladder up" or "ladder down" is requested, or the ladder movement is too slow.	
Possible causes	- No or too low X2 pressure. - Too low SRV pressure, or the valve is defective. - Valve 57Q623a/b mechanically stuck. - The ladder cylinder has an internal leakage (piston seal defective). - The ladder bearing is defective or it is tightened too firmly.	

Possible cause	Step	Test condition & Inspection	Procedure	Nominal value
No or too low X pressure	1	▶ Engine running at high idle.		
		Check the X2 pressure according to the instructions and specifications in the SERVICE MANUAL and PM-CLINIC sheets. Is the X2 pressure adjustment correct?	Yes No	Go to next step. Re-adjust and verify that the ladder is operated orderly.
Too low SRV pressure or the valve is defective	2	▶ Engine running at low idle.		
		Check the SRV pressure in the ladder circuit according to the instructions and specifications in the SERVICE MANUAL and PM-CLINIC sheets. Is the SRV pressure adjustment correct?	Yes No	Go to next step. Re-adjust and verify that the ladder is operated orderly.
Valve 57Q623a or 57K623b is mechanically stuck	3	▶ Main key switch 20S001 OFF. Maintenance safety switch 50S058 locked.		
		Disassemble the solenoid valve 57Q623a/b and check the inner part of the spool for proper condition. Is the inner part of the spool in good condition?	Yes No	Go to next step. Replace valve 57Q623a/b.
The ladder cylinder has an internal leakage (piston seal defective)	4	▶ Engine running at high idle.		
		Activate the function "ladder up" or "ladder down" until the cylinder end position is reached, and measure the temperature difference between the cylinder rod and the cylinder bottom side with an infrared thermometer gun. Is the temperature difference in the piston area higher than 10°C?	Yes No	Repair or replace the ladder cylinder. Go to next step.

SME009 - Abnormal noise coming from the work equipment (lack of grease)

[2/2]

Possible cause	Step	Test condition & Inspection	Procedure	Nominal value
Contaminated grease is used (grease barrel refilling without refilling the filter)	2	<ul style="list-style-type: none"> ▶ Main key switch 20S001 OFF. Maintenance safety switch 50S058 locked. 		
		<p>The injectors are worn out due to contaminated grease in the barrel.</p> <p>No or not enough grease causes early wear and noise at the pins and bushings of the attachment.</p> <p>Are pins and bushings worn out due to lacking grease and defective injectors?</p>	<p>Yes</p> <p>Replace the contaminated grease by specified grease.</p> <p>Clean or replace the barrel as necessary.</p> <p>Replace the defective pins and bushings on the attachment side.</p> <p>Check all grease injectors for proper function.</p> <p>Pre-lubricate all pins and bushings through the injectors until the new grease flows out.</p>	
			<p>No</p> <p>Go to next step.</p>	
Daily fault messages of the CLS system occur Download the history data via VHMS and verify the system status	3	<ul style="list-style-type: none"> ▶ Main key switch 20S001 ON. 		
		<p>Download the history data via VHMS and verify the system status.</p> <p>Do the history data show a lot of "bucket cut-off" messages due to missing grease?</p>	<p>Main key switch OFF & maintenance safety switch locked.</p> <p>Repair or replace any defective parts of the CLS system as necessary.</p> <p>Replace the defective pins and bushings on the attachment side (standardization of overriding importance).</p> <p>Check all grease injectors for proper function.</p> <p>Pre-lubricate all pins and bushings through the injectors until the new grease flows out.</p>	
Final check	4	<p>Bring the machine back into the original condition.</p> <p>Start the machine and verify that the repair was successful.</p>		

1 INTRODUCTION

2.4.11.2 PRECAUTIONS WHEN TRAVELLING IN FORWARD OR REVERSE

- Before travelling, set the machine so that sprocket (1) is behind the operator's seat (Fig. 2-21).
- If sprocket (1) is in front of the operator's cab, the machine moves in the opposite direction from the operation of the pedals (front and rear travel is reversed, left and right steering is reversed). Be extremely careful when operating the machine in this situation.

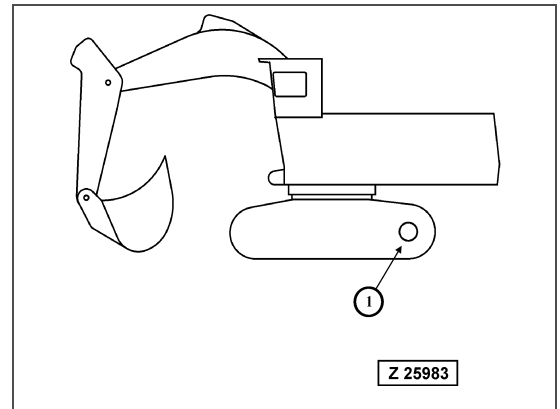

Fig. 2-21

- Before travelling, check again that there is no one in the surrounding area, and that there are no obstacles (Fig. 2-22).
- Before travelling, sound the horn to warn people in the area.
- Always operate the machine only when seated.
- Do not allow anyone apart from the operator to ride on the machine.
- Check that the travel alarm works properly.
- Secure the cab door when it is both open and closed.
- Always keep the cab door closed when operating the machine.

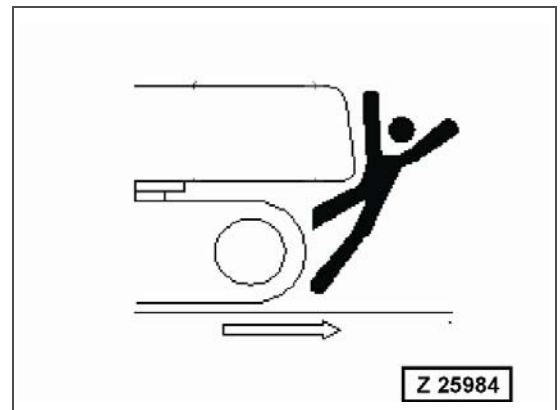

Fig. 2-22

- If there is an area to the rear of the machine which cannot be seen, position a signal person. Take special care not to hit other machines, objects or people when turning or swinging the machine (Fig. 2-23)

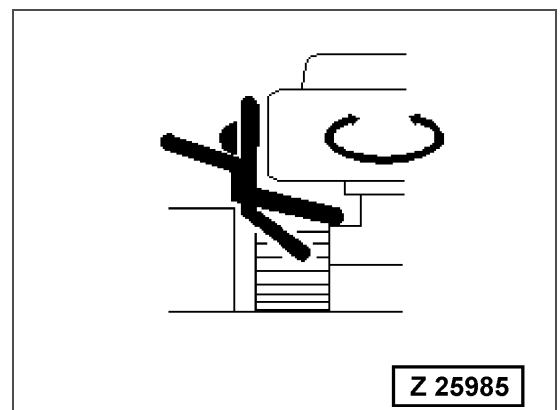

Fig. 2-23

NOTE! Always be sure to carry out the above precautions even when the machine is equipped with mirrors or camera systems.

2.7.5.3 PRIOR TO USING THE HARNESS (1), THE WEARER SHALL

- Carry out a visual check of the system or component; correct functioning and perfect working order have to be assured.
- Make sure that the recommendations for use with other components of the system be observed in conformity with the instructions for use.

The system or component must no longer be used, if there are any doubts in respect of its safe condition. The equipment has to be inspected by the manufacturer or by a qualified person.

It is essential for safety reasons that a fall protection system or system component which has already been subjected to fall be removed from service and sent back to the manufacturer or an authorized qualified repair shop for maintenance and renewed testing.

Fall protection systems have to be treated with care and to be kept clean and ready for use. It has to be warned against bringing the systems into contact with acids or other caustic liquids and gases, oils, detergents, or sharp-edged objects.

Should the harness have become wet during use or cleaning, do not dry near a fire or other sources of heat, but rather in a natural way in not too warm rooms. Keep the harness freely suspended or loosely rolled up.

When using the fall protection systems, the pertaining safety regulations in force and the "Rules for Use of Personal Fall Arrest Systems" have to be observed for protection against danger.

At least every 12 months, the safety harness and its components have to be inspected by a competent person authorized by the manufacturer and maintained, if the manufacturer considers it necessary.



2.7.5.4 RECOMMENDATIONS FOR USE OF THE HOLDING HOOKS AND HOLD-BACK HOOKS OF THE SAFETY HARNESS (1),

During the holding function, the connectors may only be placed around a mast or other construction between the two holding hooks, so that free fall is limited to max. 0.5 m.

It should be strictly seen to it that the connector be not slung around constructions with too small diameter or sharp edges.

With the lateral holding hooks, work may only be carried out on horizontal or almost horizontal surfaces (roofs). The connectors have to be adjusted in such a way that the area, where danger of falling down prevails, cannot be reached.

3.2.5.2 REPLACEMENT OF THE STARTER MOTOR.

Special tools:	n/a
Additional equipment:	n/a
	Starter motor: 26 kg
	If there is nothing mentioned explicitly, tighten all bolts according to KOMATSU company standard, refer to section 6.5 on page 6-10 .



1. Carry out installation in reverse order to removal



Tightening torque for starter motor mounting bolts (multi-point): 195 Nm

3.2.6 BATTERIES

3.2.6.1 REMOVAL OF THE BATTERIES

Special tools:	n/a
Additional equipment:	Crane or forklift
	Battery: 62 kg each
	Dogman/rigger Certified electrician
	Follow the precautions for battery handling given in the safety chapter, refer to section 2.5.2.2 on page 2-34 .

1. Prepare an area of flat ground large enough to accommodate the machine and the additional working equipment (crane, mobile working platforms, forklift, etc.).
2. Park the machine on the prepared flat ground area.

REMARKS: If the ground condition is too poor to guarantee safe and stable stand of the machine and the additional working equipment (crane, mobile working platforms, forklift, etc.), make sure that the machine is moved to any location with appropriate ground condition.

3. Isolate the machine according to local regulations.

DANGER

EXPLOSIVE HYDROGEN GAS!

Blindness, serious injury, permanent disfigurement, and scarring will result by the explosion caused by hydrogen gas.

Never allow sparks or open flame near the batteries.

DO NOT smoke or use an open flame when working at the batteries.

DO NOT short circuit or ground any terminals of the batteries.

The combination of the high elasticity of its leaf springs with complimentary viscous damping by oil displacement, ensures that the GEISLINGER-COUPLING removes major critical speeds outside the engine speed range and dampens minor torsional vibrations effectively.

The widest engine speed range free of vibration periods and dangerous resonance is thus obtained.

Furthermore, employment of these couplings with their highly dampening characteristics generally results in lower stress in all engine driving shafts and gears as well as in the crankshaft permitting further power development on standard components.



In any similar application, a simple vibration damper and/or a pure flexible coupling would not confer the same advantages.

The springs (Fig. 3-51, Pos. 3) together with the inner driving and outer driven member, form the chambers A and B (Fig. 3-51, Pos. A and B), which are filled with oil.

If the outer member is displaced in relation to the inner member, the deflection of the leaf springs displaces oil from one chamber to the next, by this action the relative movements of the two members of the coupling are braked and the vibrations are dampened.

The spacer (Fig. 3-51, Pos. 8) limits the movement of the leaf springs.

3.4.1.1 REMOVAL OF THE GEISLINGER COUPLING



Special tools:	n/a
Additional equipment:	Swivel hoist ring: M 16 Chain hoist Crane
	Coupling assembly: 165 kg
	Dogman/rigger

1. Prepare an area of flat ground large enough to accommodate the machine and the additional working equipment (crane, mobile working platforms, forklift, etc.).
2. Park the machine on the prepared flat ground area.

REMARKS: If the ground condition is too poor to guarantee safe and stable stand of the machine and the additional working equipment (crane, mobile working platforms, forklift, etc.), make sure that the machine is moved to any location with appropriate ground condition.

3. Isolate the machine according to local regulations.

3.5.5.2 REPLACEMENT OF THE RADIATOR FAN DRIVE PUMP

Special tools:	Rotational speed infrared probe DS03, PN 793 788 73
Additional equipment:	Paste "Optimol White" PN 999 039
	Radiator fan drive pump: 48.5 kg
	Dogman/rigger
	If there is nothing mentioned explicitly, tighten all bolts according to KOMATSU company standard, refer to section 6.5 on page 6-10.

1. Replace the pump's screen filter at the suction oil reservoir and the high pressure filter.
2. Carry out installation in reverse order to removal.

REMARKS: Use "Optimol White" on the spline shafts of the pumps.

Always use new O-rings at the SAE-flange connections.

Use new bolts (Fig. 3-80, Pos. 4) with grade 10.9 at the mounting flanges.
Tighten the bolts with the specified torque.



Tightening torque for mounting bolts: 265 Nm



Refill the oil collector reservoir (Fig. 3-81, Pos. 1) for the spline shaft housing between the radiator fan drive pump (Fig. 3-81, Pos. 3) and the hydraulic cooler fan drive pump (Fig. 3-81, Pos. 2) with lubricant.

For the proper lubricant, refer to the Operation & Maintenance Manual, chapter 4, section "FLUIDS AND LUBRICANTS".

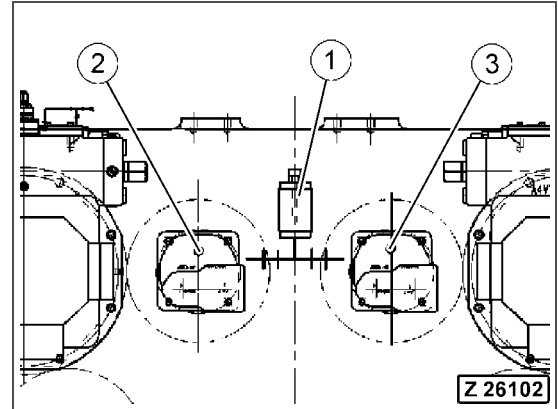





Fig. 3-81

3. Open main gate valve completely.
4. Bleed air from the hydraulic system, refer to the Operation & Maintenance Manual, chapter 4, section "HYDRAULIC SYSTEM - CHANGE OIL, REPLACE SUCTION STRAINERS AND PULSATION DAMPER".
5. Add hydraulic oil up to the specified level.
6. Check for leaks and proper operation.
7. Check the hydraulic oil level again and add oil if required.
8. Check and adjust the speed of the radiator fan, refer to the Operation & Maintenance Manual, chapter 2, section "RADIATOR FAN DRIVE SPEED ADJUSTMENT".

3.6.1.8 REPLACEMENT OF THE HYDRAULIC OIL COOLER ASSEMBLY

Special tools:	Hydraulic torque wrench, PN 232 614 40 Electro-hydraulic pump set, PN 793 375 73 46 mm hexagon impact socket wrench, PN 232 265 40
Additional equipment:	Safety harness in conformity with DIN EN 361 Crane Mobile elevator working platform Compound "KP2K", PN 324 969 40
	Hydraulic oil cooler assembly: 3854 kg
	Dogman/rigger
	If there is nothing mentioned explicitly, tighten all bolts according to KOMATSU company standard, refer to section 6.5 on page 6-10.

NOTE! Always wear the safety harness when working at the hydraulic oil cooler frame and on the elevator working platform.

1. Carry out installation in reverse order to removal.

REMARKS: Use new mounting bolts (Fig. 3-114, Pos. 1 and 2) of grade 10.9.
Apply compound "KP2K", PN 324 969 40 and tighten the bolts to the specified tightening torque.



Tightening torque for mounting bolts: 1770 Nm

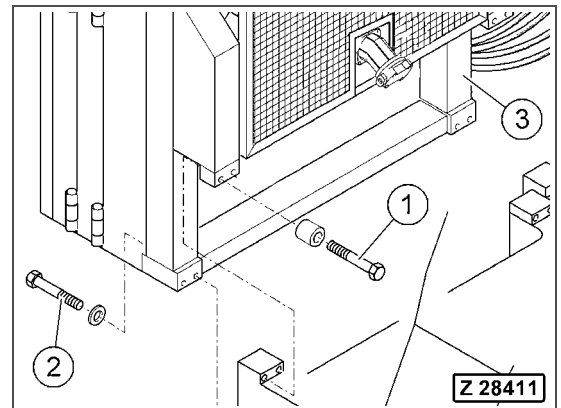

Fig. 3-114

2. Bleed air from the hydraulic system, refer to the Operation & Maintenance Manual, chapter 4, section "HYDRAULIC SYSTEM - CHANGE OIL, REPLACE SUCTION STRAINERS AND PULSATION DAMPER".
3. Add hydraulic oil up to the specified level.
4. Add PTO gear oil to the specified level.

-
12. At main control valve block II / IV insert a swivel hoist ring into a thread of the SAE flange instead of one bolt when installing the blind plug.
At main control valve block I / III insert a swivel hoist ring into the thread of a pressure filter mounting bolt.

REMARKS: If rigid lifting eyes are installed at the main control valve blocks, replace them by swivel hoist rings.

13. Sling main control valve block at the hoist rings.

DANGER



FLOATING LOADS!

Death or serious injury will result due to swinging or downfalling of heavy machine parts.

When moving machine parts using a crane, make sure that nobody steps below or in close range to the lifted machine part.

14. Remove the mounting bolts and dismantle the main control valve block from the control valve carrier using a crane.

3.6.8.1 REMOVAL OF THROTTLE CHECK VALVES

Special tools:	n/a
Additional equipment:	Crane Oil drain pan
	Throttle check valve: 20.5 kg
	Dogman/rigger
	For further information about the needed blind plugs, refer to section 6.6 on page 6-14 .

1. Prepare an area of flat ground large enough to accommodate the machine and the additional working equipment (crane, mobile working platforms, forklift, etc.).
2. Park the machine on the prepared flat ground area.

REMARKS: If the ground condition is too poor to guarantee safe and stable stand of the machine and the additional working equipment (crane, mobile working platforms, forklift, etc.), make sure that the machine is moved to any location with appropriate ground condition.

3. Relieve the pressure in the hydraulic system, refer to the Operation & Maintenance Manual, chapter 3, section "RELIEVE PRESSURE IN THE HYDRAULIC SYSTEM".
4. Isolate the machine according to local regulations.
5. Transfuse the oil from the return manifold into the main oil reservoir, refer to the PARTS & SERVICE NEWS No. "AH10530".

WARNING

HOT HYDRAULIC OIL!

May result in personal injury from heated oil.

Do not carry out the following work on a hot machine. Wait until the temperature of the hydraulic oil is below 50 °C.

REMARKS: Replace all O-rings.
For further information relating the parking brake, refer to the PARTS & SERVICE NEWS No. "AH03509".

1. Install the thrust washer (Fig. 3-183, Pos. 2).
2. Install the drive shaft (Fig. 3-183, Pos. 12).

REMARKS: Apply "Optimol White" to the spline shaft.

3. Install new discs according to the following order:
At first an outer disc (Fig. 3-183, Pos. 4), then an inner disc (Fig. 3-183, Pos. 3), and then a sinus spacer ring (Fig. 3-183, Pos. 5). Continue with this order for all other discs.

REMARKS: Apply oil to the discs.

DANGER

TOO HIGH PRESSURE APPLIED!

**Serious injury, permanent disfigurement and scarring, or death will result.
The cylinder assembly will burst when the applied pressure exceeds 60 bar.**

Do not apply any pressure that exceeds 60 bar to the cylinder assembly.

4. Before reinstallation of the cylinder assembly (Fig. 3-183, Pos. 17), apply pressure (max. 60 bar) to the assembly, otherwise the two socket head cap bolts (Fig. 3-183, Pos. 14) will be pre-stressed (spring loaded).
5. Install the cylinder assembly (Fig. 3-183, Pos. 17).
6. Carry out further installation in reverse order to removal.

NOTICE

BRAKE NOT BLED!

The slew parking brake can not be released completely due to air in the hydraulic system. This may cause severe damage to the brake lamellas.

Before initial operation or after repairs on the hydraulic circuit, all slew parking brakes have to be vented at the oil pressure port (Fig. 3-183, Pos. 13).

7. Bleed the slew parking brake at the pressure oil port.

NOTE! Make sure to use the specified bolts and torque for the swing motor mounting bolts, [refer to section 3.7.2.2 on page 3-159](#).



Fill oil to the motor adapter housing, approx. 0.6 liters.

Refer to the Operation & Maintenance Manual, chapter 4, section "SWING GEAR AND MOTOR ADAPTER HOUSING - CHANGE OIL".

For the proper lubricant, refer to the Operation & Maintenance Manual, chapter 4, section "FLUIDS AND LUBRICANTS".

8. Add hydraulic oil up to the specified level.
9. Check slew parking brake for proper function. Refer to the Service Manual for further information.

Legend for Fig. 3-205:

(1)	Lubrication pump station	(14)	Lubricant feed line from injector to lubrication pinion
(4)	Main pump control solenoid valve (pump on/off)	(18)	Lubricant container
(8)	Lubricant supply line from pump to injector	(23)	Lubrication pinion
(9)	Lubricant pressure relieve solenoid valve	(24)	Lubrication pinion center shaft with distributing drillings
(12)	End line pressure switch	(25)	Lubricant outlet
(13)	Grease injectors		

The Swing circle lubrication system (SLS) lubricates the open gear of the outer slew ring with special open gear lubricant. The lubricant pump station (Fig. 3-205, Pos. 1) is the same as for the central lubrication system (CLS), refer to section 3.8 on page 3-192. To apply the lubricant equably to the outer slew ring gear teeth (Fig. 3-205, Pos. 26), a special lubrication pinion (Fig. 3-205, Pos. 23) is mounted near the drive pinion of each slew gear.

The lubrication pinion (Fig. 3-205, Pos. 23) distributes the lubricant from the injectors (Fig. 3-205, Pos. 13) constantly to the teeth. Normally two or more small SL1 injectors (Fig. 3-205, Pos. 13) are parallel connected to supply the required amount of lubricant to the lubrication pinion.

The pinion center shaft (Fig. 3-205, Pos. 24) acts as a rotary joint and distributes lubricant through radial drillings only to the teeth that are in contact with the outer slew ring gear teeth. Outlet bores (Fig. 3-205, Pos. 25) on different position of the pinion gear distribute the lubricant equably to the outer slew ring gear teeth (Fig. 3-205, Pos. 26).

REMARKS: The PC4000-6 is equipped with two lubrication pinions, one at each slew gear.

3.7.6.1 REMOVAL OF THE LUBRICATION PINION ASSEMBLY

Special tools:	n/a
Additional equipment:	Safety harness in conformity with DIN EN 361 Mobile elevator working platform
	Pinion cover: 2.5 kg Lubrication pinion assembly: 14 kg



NOTE! Always wear a safety harness when working at the lubrication pinion on the elevator working platform.

1. Prepare an area of flat ground large enough to accommodate the machine and the additional working equipment (crane, mobile working platforms, forklift, etc.).
2. Park the machine on the prepared flat ground area with the lubrication pinion placed between the crawler carriers, so that the lubrication pinion can be accessed by a mobile working platform.

REMARKS: If the ground condition is too poor to guarantee safe and stable stand of the machine and the additional working equipment (crane, mobile working platforms, forklift, etc.), make sure that the machine is moved to any location with appropriate ground condition.

3. Isolate the machine according to local regulations.

3.9.5.2 REPLACEMENT OF THE OPERATOR'S SEAT

Special tools:	n/a
Additional equipment:	Crane
	Operator's seat: 62 kg
	Dogman/rigger
	If there is nothing mentioned explicitly, tighten all bolts according to KOMATSU company standard, refer to section 6.5 on page 6-10 .

1. Carry out installation in reverse order to removal.

REMARKS: A second person is required to carry the operator's seat into the operator's cab.

14. Install the shackles delivered with the machine to the flanges of the counterweight and attach both shackles to a crane.
15. Attach the superstructure by means of the boom cylinder pins to a second crane.
16. Remove all bolts (Fig. 3-246, Pos. 1) and washers (Fig. 3-246, Pos. 2) attaching the slew ring to the undercarriage.

NOTE! Before lifting the superstructure, make sure that the crane operators are trained in dual crane lift.

⚠ DANGER

FLOATING LOADS!

Death or serious injury will result due to swinging or downfalling of heavy machine parts.

When moving machine parts using a crane, make sure that nobody steps below or in close range to the lifted machine part.

NOTICE

CRASHING OF THE SUPERSTRUCTURE!

Severe damages to the superstructure may result.



Too weakly dimensioned supports may cause the superstructure to crash due to destruction of the supports.

Supports need to be substantial enough to carry total weight of the superstructure (without counterweight, fluids and attachment), total weight 110,500 kg.

17. Lift off the superstructure using the two cranes and rest it on appropriate supports on the ground.

4.2.2 SPROCKET

4.2.2.1 REMOVAL OF THE SPROCKET

Special tools:	n/a
Additional equipment:	Personal Protective Equipment (PPE) Hydraulic torque wrench, PN 232 614 40 Electro-hydraulic pump set, PN 793 375 73 46 mm hexagon impact socket wrench, PN 232 265 40 2 x Crane Pulling bolts M30
	Sprocket: 3050 Kg Hollow shaft: 360 kg Drive shaft: 630 kg
	Dogman/rigger

KOMATSU recommends to change the freeze in bushes (Fig. 4-13, Pos. 1 + Pos. 3) when changing the sprocket. Therefore the travel gear (Fig. 4-13, Pos. 4) has to be removed, refer to section 4.2.11.1 on page 4-63.

The removal and installation procedure of the inner flange bearing (Fig. 4-13, Pos. 6) is analogously to the removal and installation procedure of the outer flange bearing (Fig. 4-13, Pos. 5) including the tightening torques.

Only for removal of the sprocket (Fig. 4-13, Pos. 2) it is not necessary to remove the travel gear (Fig. 4-13, Pos. 4).

Subsequently the removal of the sprocket without removing the travel gear is described.

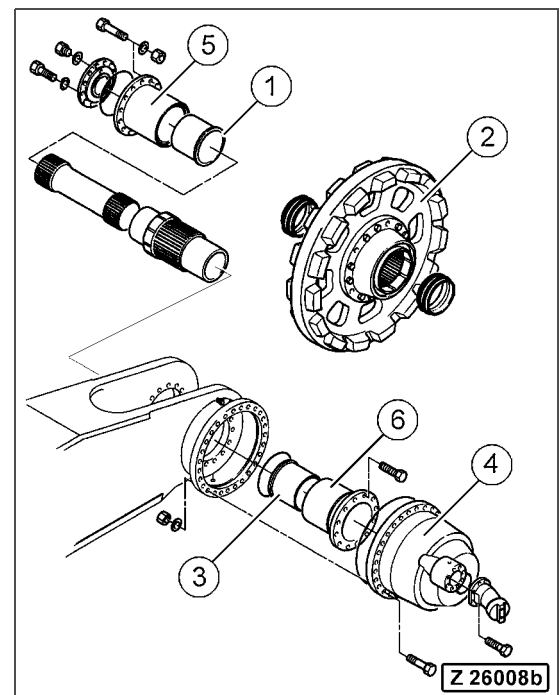

Fig. 4-13

NOTE! Ensure appropriate (PPE) Personal Protective Equipment is used for handling during the task. There may be sharp edges on the worn sprocket that is being removed.

4.2.7.2 SUBSTITUTE THE HYDRAULIC HOSES INSIDE THE CAR BODY

Hydraulic hoses (Fig. 4-39, Pos. 2 resp. 5):

1. Carry out the precursory work, refer to section 4.2.7.1 on page 4-31.
2. Remove the hose straps fixing the hydraulic hoses to other hydraulic hoses.
3. Disconnect both ends of the hydraulic hose (Fig. 4-39, Pos. 2 resp. 5) and remove the hydraulic hose.

REMARKS: When the hose is disconnected, hydraulic oil from inside the piping and/or the track tensioning valve block will flow out.
Catch it in an oil pan.
Cap the openings with blind plugs to avoid contamination.

4. Install the new hydraulic hose in reverse order to removal.
5. Carry out the subsequent work, refer to section 4.2.7.5 on page 4-35.

4.2.7.3 SUBSTITUTE THE HYDRAULIC HOSES BETWEEN CAR BODY AND CRAWLER FRAME

Hydraulic hoses (Fig. 4-39, Pos. 1):

1. Carry out the precursory work, refer to section 4.2.7.1 on page 4-31.
2. Remove the hose straps fixing the hydraulic hoses to other hydraulic hoses.
3. Remove the cover (Fig. 4-40, Pos. 1).
4. Clear the hydraulic hose to be removed by opening the clamp (Fig. 4-39, Type. D) near the high pressure accumulator.

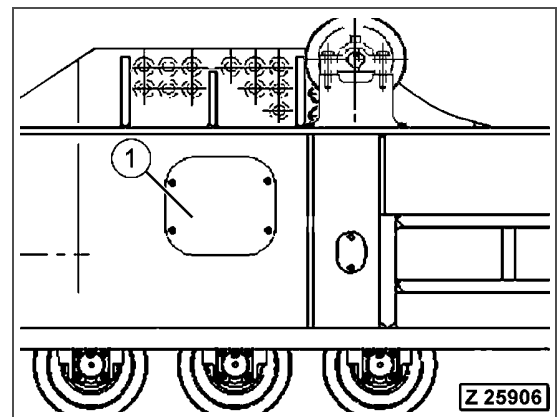

Fig. 4-40

5. Disconnect the pressure hoses (Fig. 4-41, Pos. 1) for the track tensioning from the shut-off cocks (Fig. 4-41, Pos. 2).

REMARKS: When the pressure hoses are removed, the oil inside the piping will flow out. Catch it in an oil pan.
Cap the openings with blind plugs to avoid contamination.

6. Connect the new hose to the old one using an appropriate union.
7. **Pinned undercarriage only:**
Slide the hydraulic hose through the hose (Fig. 4-39, Pos. 7) between car body and crawler carrier.

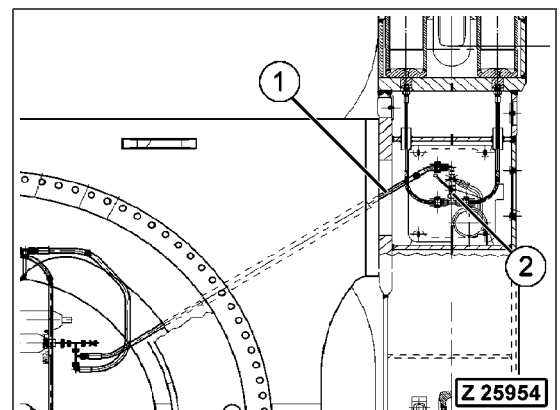



Fig. 4-41

4.2.10.4 REMOVAL/DISASSEMBLY OF THE TRAVEL PARKING BRAKE (ZOLLERN)

Special tools:	n/a
Additional equipment:	n/a Oil drain pan
 No entire assembly.	Single pars < 25 kg
	For further information about the needed blind plugs, refer to section 6.6 on page 6-14.

REMARKS: The travel parking brake must be disassembled from the travel gear housing.

1. Prepare an area of flat ground large enough to accommodate the machine and the additional working equipment (crane, mobile working platforms, forklift, etc.).
2. Park the machine on the prepared flat ground area with the attachment placed at the final drive end of the machine, counterweight above guide wheels.
3. Place wedges at front and rear side of both crawlers and lower the bucket onto the ground.
4. Relieve the pressure in the hydraulic system. Refer to the Operation & Maintenance Manual, chapter 3, section "RELIEVE PRESSURE IN THE HYDRAULIC SYSTEM".
5. Isolate the machine according to local regulations.



Drain oil of the motor adapter housing, approx. 0.6 liters.

Refer to Operation & Maintenance Manual, chapter 4, section "TRAVEL GEARS, BRAKE AND MOTOR ADAPTER HOUSINGS - CHANGE OIL".

6. Remove the travel motor, [refer to section 4.2.9.1 on page 4-42.](#) The hydraulic hoses may remain connected at the hydraulic motors.

WARNING

HOT HYDRAULIC OIL!

May result in personal injury from heated oil.

Do not carry out the following work on a hot machine. Wait until the temperature of the hydraulic oil is below 50 °C.

DANGER

HYDRAULIC PRESSURE!

The hydraulic system may be pressurized. Opening any hydraulic lines under pressure will result in blindness, serious injury or permanent disfigurement.

Make sure that the pressure is relieved before any hydraulic lines will be removed.

7. Disconnect the pressure hose from the control pressure port at the brake.

⚠ DANGER**FLOATING LOADS!**

Death or serious injury will result due to swinging or downfalling of heavy machine parts.

When moving machine parts using a crane, make sure that nobody steps below or in close range to the lifted machine part.

24. Lift up the left crawler carrier and align it with the car body.

NOTE! Before lifting the crawler carrier make sure that the crane operators are trained in dual crane lift.

25. Align the lower borings first and insert the mounting pins (Fig. 4-78, Pos. 5).

REMARKS: Lubricate the pins with AL-Compound, PN 509 623 98.

26. Align the upper borings and insert the mounting pins.

27. Install the retainer plates (Fig. 4-78, Pos. 7) and bolts (Fig. 4-78, Pos. 6) inclusive washers.



28. Lift the undercarriage as far as it is necessary to remove the supports.

29. Rest the undercarriage to the ground.

30. Carry out further installation in reverse order to removal.

31. Bleed the track tensioning system. Refer to Operation & Maintenance Manual, chapter 4, section "CRAWLER TRACK - INSPECTION".

5 ATTACHMENT

Special tools:	n/a
Additional equipment:	Safety harness in conformity with EN 361 2 x crane Mobile elevator working platform
	Stick cylinder: 3150 kg each Pin stick cylinder/stick: 86 kg Pin stick cylinder/boom: 123 kg
	Dogman/rigger
	For further information about the needed blind plugs, refer to section 6.6 on page 6-14.

REMARKS: At first the wear of the bushes in the hydraulic cylinder should be checked, refer to the PARTS & SERVICE NEWS No. "AH08508".

NOTE! Always wear a safety harness when working at the attachment.
Most of the following operations require the use of men safety cages on elevator working platforms.

1. Prepare an area of flat ground large enough to accommodate the machine and the additional working equipment (crane, mobile working platforms, forklift, etc.).
2. Park the machine on the prepared flat area and position the bucket on the ground with the cylinders in partially extended position (Fig. 5-29).

REMARKS: If the ground condition is too poor to guarantee safe and stable stand of the machine and the additional working equipment (crane, mobile working platforms, forklift, etc.), make sure that the machine is moved to any location with appropriate ground condition.

3. Relieve the pressure in the hydraulic system, refer to the Operation & Maintenance Manual, chapter 3, section "RELIEVE PRESSURE IN THE HYDRAULIC SYSTEM".
4. Isolate the machine according to local regulations.
5. Remove grease feed lines and fittings from the stick cylinder(s) to be removed.
6. Sling the cylinder (Fig. 5-30, Pos. 1) to be removed.

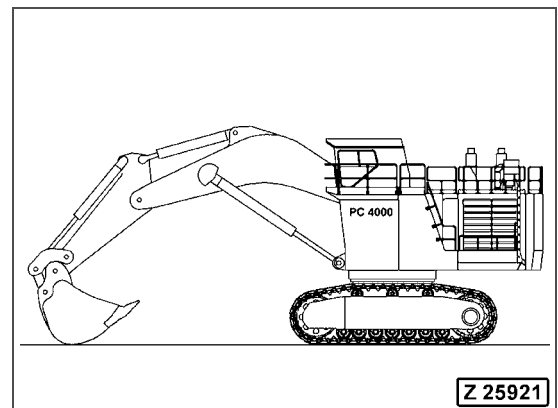

Fig. 5-29

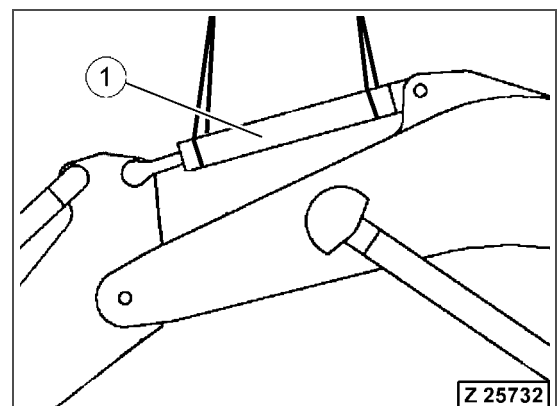





Fig. 5-30

5.1.4.2 REPLACEMENT OF THE BUCKET LINK ROD

Special tools:	Thread protector PN 409 329 40
Additional equipment:	Safety harness in conformity with DIN EN 361 3 x crane Mobile elevator working platform
	Bucket link rod: 1805 kg Steering rod: 1128 kg Pin bucket cylinder/steering rods: 711 kg Pin bucket/bucket link rod: 514 kg Nut-cap: 35 kg
	Dogman/rigger
	If there is nothing mentioned explicitly, tighten all bolts according to KOMATSU company standard, refer to section 6.5 on page 6-10.

NOTE! Always wear a safety harness when working at the attachment.
Most of the following operations require the use of men safety cages on elevator working platforms.

1. Check the grease filling in the chambers of the bucket link rod, refer to the PARTS & SERVICE NEWS No. "AH09522".
2. Slip the seals (Fig. 5-57, Pos. 1) to get affixed with seal fixing rings (Fig. 5-57, Pos. 2) onto the flanges of the bushes installed in the bucket and the steering rods. Use new seals.

REMARKS: During installation there is not enough space to insert these seals.

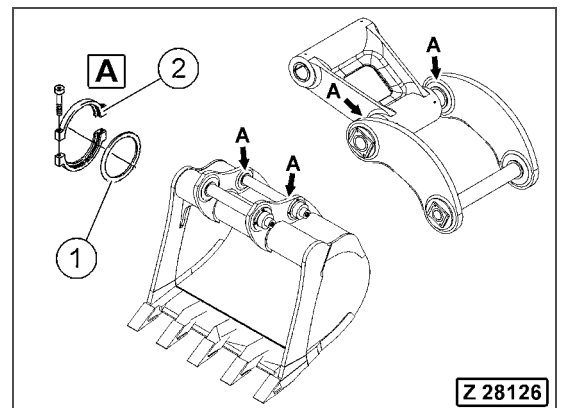

Fig. 5-57

3. Carry out further installation in reverse order to removal.

REMARKS: Use new cotter pins and o-rings at the nut-caps.

⚠ WARNING**HOT HYDRAULIC OIL!**

May result in personal injury from heated oil.

Do not carry out the following work on a hot machine. Wait until the temperature of the hydraulic oil is below 50 °C.

⚠ DANGER**HYDRAULIC PRESSURE!**

The hydraulic system may be pressurized. Opening any hydraulic lines under pressure will result in blindness, serious injury or permanent disfigurement.

Make sure that the pressure is relieved before any hydraulic lines will be removed.



7. Remove the bolts (Fig. 5-79, Pos. 2) and disconnect the SAE-flanges from the bucket cylinder and the hydraulic tube (Fig. 5-79, Pos. 5) at the boom.

REMARKS: When the hydraulic hoses are disconnected, the oil inside the piping will flow out. Catch it in an oil pan.
Cap the openings with blind plugs to avoid contamination.

8. Remove the hydraulic hose using a crane.
9. Replace the bucket cylinder hoses by a new one and carry out installation in reverse order to removal.

REMARKS: Always replace the O-rings (Fig. 5-79, Pos. 3) and the rings (Fig. 5-79, Pos. 4) at the SAE-flange connections.

10. Substitute all other bucket cylinder hoses if required, using the same procedure.
11. Perform the bleeding procedure for the bucket cylinders. Refer to the PARTS & SERVICE NEWS No. "AH06524".
12. Add hydraulic oil up to the specified level.
13. Check for leaks and the cylinders operation.
14. Check hydraulic oil level again and add oil if required.

Special tools:	n/a
Additional equipment:	Safety harness in conformity with DIN EN 361 2 x crane 2 x chain hoist Mobile elevator working platform (telescopic or articulated boom lift)
	Stick: 14,350 kg Pin stick/boom: 197 kg Pin stick cylinder/stick: 58 kg
	Dogman/rigger
	For further information about the needed blind plugs, refer to section 6.6 on page 6-14.

NOTE! Always wear a safety harness when working at the attachment.
Most of the following operations require the use of men safety cages on elevator working platforms.

1. Prepare an area of flat ground large enough to accommodate the machine and the additional working equipment (crane, mobile working platforms, forklift, etc.).
2. Park the machine on the prepared flat area and position the bucket on the ground with the stick and the bucket cylinders in vertical position (Fig. 5-98).

REMARKS: If the ground condition is too poor to guarantee safe and stable stand of the machine and the additional working equipment (crane, mobile working platforms, forklift, etc.), make sure that the machine is moved to any location with appropriate ground condition.

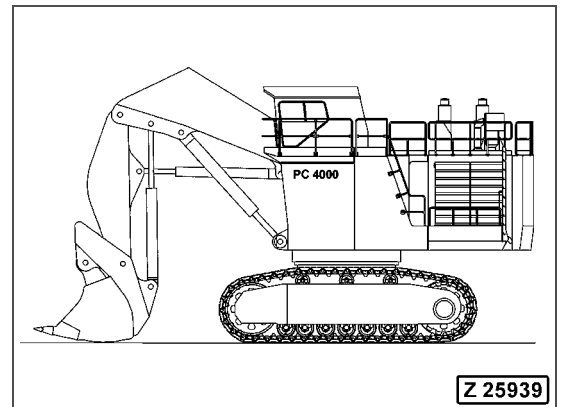





Fig. 5-98

3. Relieve the pressure in the hydraulic system, refer to the Operation & Maintenance Manual, chapter 3, section "RELIEVE THE PRESSURE IN THE HYDRAULIC SYSTEM".
4. Isolate the machine according to local regulations.
5. Remove the bull clam bucket, refer to section 5.2.4.1 on page 5-112.

Special tools:	Installation tool, PN 909 348 40
Additional equipment:	Safety harness in conformity with DIN EN 361 Crane Mobile elevator working platform (telescopic or articulated boom lift) Forklift 5 t Oil drain pan
	Bucket cylinder: 2730 kg Pin bucket cylinder/boom: 108 kg Pin bucket cylinder/bucket: 125 kg
	Dogman/rigger
	For further information about the needed blind plugs, refer to section 6.6 on page 6-14.

NOTE! Always wear a safety harness when working at the attachment.
Most of the following operations require the use of men safety cages on elevator working platforms.

REMARKS: Before the disassembly of the attachment, the wear of the bushes of the hydraulic cylinders at the attachment should be checked. Refer to the PARTS & SERVICE NEWS No. "AH08508".

1. Prepare an area of flat ground large enough to accommodate the machine and the additional working equipment (crane, mobile working platforms, forklift, etc.).
2. Park the machine on the prepared flat area with the superstructure turned by 90° and position the bucket on the ground as shown (Fig. 5-118), bucket cylinders in vertical position.

REMARKS: If the ground condition is too poor to guarantee safe and stable stand of the machine and the additional working equipment (crane, mobile working platforms, forklift, etc.), make sure that the machine is moved to any location with appropriate ground condition.

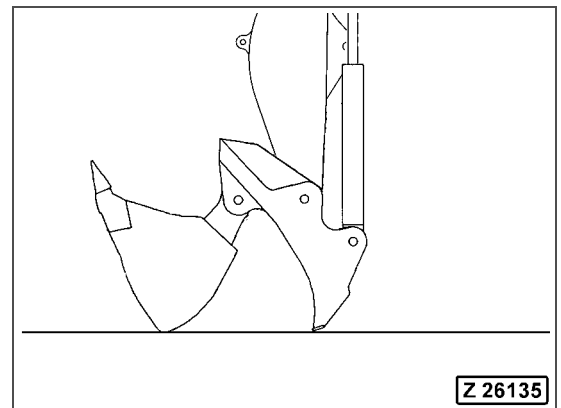

Fig. 5-118

3. Relieve the pressure in the hydraulic system, refer to the Operation & Maintenance Manual, chapter 3, section "RELIEVE PRESSURE IN THE HYDRAULIC SYSTEM".
4. Isolate the machine according to local regulations.
5. Disconnect the grease feeding lines from the bucket cylinder(s) to be removed.
6. Install the installation tool, PN 909 348 40 at the piston rod side of the bucket cylinder, refer to section 5.2.1 on page 5-75.
7. Support the bucket cylinder by means of the installation tool using the forks of a forklift.

6. Sling the hydraulic hose (Fig. 5-143, Pos. 1 or 2) to be removed.

WARNING

HOT HYDRAULIC OIL!

May result in personal injury from heated oil.

Do not carry out the following work on a hot machine. Wait until the temperature of the hydraulic oil is below 50 °C.

DANGER

HYDRAULIC PRESSURE!

The hydraulic system may be pressurized. Opening any hydraulic lines under pressure will result in blindness, serious injury or permanent disfigurement.

Make sure that the pressure is relieved before any hydraulic lines will be removed.

7. Remove the bolts (Fig. 5-143, Pos. 3) and disconnect the SAE-flanges from the boom cylinder (Fig. 5-143, Pos. 6) and from the hydraulic tube at the boom.

REMARKS: When the hydraulic hoses are disconnected, the oil inside the piping will flow out. Catch it in an oil pan.
Cap the openings with blind plugs to avoid contamination.

8. Remove the hydraulic hose using a crane.
9. Replace the boom cylinder hoses by a new one and carry out installation in reverse order to removal.

REMARKS: Always replace the O-rings (Fig. 5-143, Pos. 4) and the rings (Fig. 5-143, Pos. 5) at the SAE-flange connections.

10. Substitute the other boom cylinder hoses if required, using the same procedure.
11. Perform the bleeding procedure for the boom cylinder(s). Refer to PARTS & SERVICE BULLETIN No. "AH06524".
12. Add hydraulic oil up to the specified level.
13. Check for leaks and the cylinders operation.
14. Check hydraulic oil level again and add oil if required.

5. Disconnect all grease lines (Fig. 5-162, Pos. 2) from the metering valve assemblies (Fig. 5-162, Pos. 5).
6. Disconnect the grease feeding line at the union (Fig. 5-162, Pos. 3).
7. Remove the bolts (Fig. 5-162, Pos. 4), and remove the metering valve assemblies (Fig. 5-162, Pos. 5) from the boom (Fig. 5-162, Pos. 1).

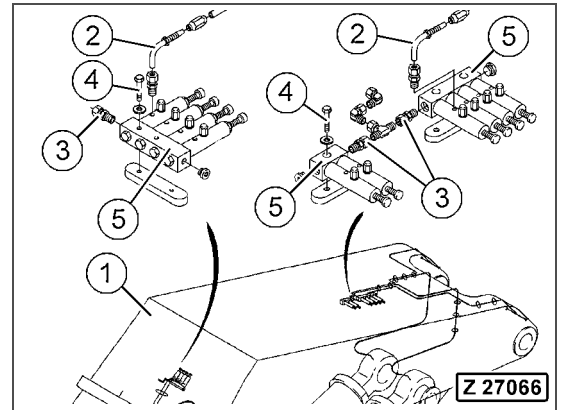

Fig. 5-162

8. Remove the adapter bolt (Fig. 5-163, Pos. 2) and remove the valve housing (Fig. 5-163, Pos. 1) from the metering valve assembly (Fig. 5-163, Pos. 4).

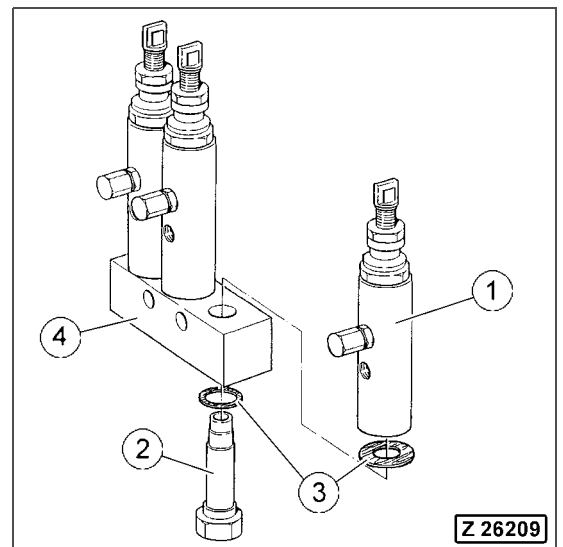



Fig. 5-163







6.7.4 NM- FT.LB

	0	1	2	3	4	5	6	7	8	9
0	0	0.74	1.47	2.21	2.95	3.69	4.42	5.16	5.90	6.63
10	7.37	8.11	8.84	9.58	10.32	11.06	11.79	12.53	13.27	14.00
20	14.74	15.48	16.21	16.95	17.69	18.43	19.16	19.90	20.64	21.37
30	22.11	22.85	23.58	24.32	25.06	25.80	26.53	27.27	28.01	28.74
40	29.48	30.22	30.95	31.69	32.43	33.17	33.90	34.64	35.38	36.11
50	36.85	37.59	38.32	39.06	39.80	40.54	41.27	42.01	42.75	43.48
60	44.22	44.96	45.69	46.43	47.17	47.91	48.64	49.38	50.12	50.85
70	51.59	52.33	53.06	53.80	54.54	55.28	56.01	56.75	57.49	58.22
80	58.96	59.70	60.43	61.17	61.91	62.65	63.38	64.12	64.86	65.59
90	66.33	67.07	67.80	68.54	69.28	70.02	70.75	71.49	72.23	72.96
100	73.70	74.44	75.17	75.91	76.65	77.39	78.12	78.86	79.60	80.33
110	81.07	81.81	82.54	83.28	84.02	84.76	85.49	86.23	86.97	87.70
120	88.44	89.18	89.91	90.65	91.39	92.13	92.86	93.60	94.34	95.07
130	95.81	96.55	97.28	98.02	98.76	99.50	100.23	100.97	101.71	102.44
140	103.18	103.92	104.65	105.39	106.13	106.87	107.60	108.34	109.08	109.81
150	110.55	111.29	112.02	112.76	113.50	114.24	114.97	115.71	116.45	117.18
160	117.92	118.66	119.39	120.13	120.87	121.61	122.34	123.08	123.82	124.55
170	125.29	126.03	126.76	127.50	128.24	128.98	129.71	130.45	131.19	131.92
180	132.66	133.40	134.13	134.87	135.61	136.35	137.08	137.82	138.56	139.29
190	140.03	140.77	141.50	142.24	142.98	143.72	144.45	145.19	145.93	146.66
200	147.40	148.14	148.87	149.61	150.35	151.09	151.82	152.56	153.30	154.03

1 Nm = 0.737 FT.LB

ET-Nr. / Part-No.	Werkzeug	Description	
----------------------	----------	-------------	---

Ausgabe: 11. November 2011
Release: November 11, 2011

232 759 40	<p>Hochleistungs-Hydraulik-Kraftschrauber & Hydraulikaggregat als Satz, Drehmoment 390 - 3.934 Nm</p> <p>Der Satz beinhaltet:</p> <ul style="list-style-type: none"> Hydraulischer Kraftschrauber (232 614 40) 1" Antrieb inklusive Reaktionsarm Hochdruck Hydraulikaggregat (793 375 73) 230 V Versorgungsspannung 3-Stufen Förderleistung Druckverstellung bis 700 bar inkl. Digitalmanometer und Öl inkl. Fernbedienung mit 5 m Kabel Inkl. Sicherheitskupplungen Hochdruckschlauch NW 6 x 5000 (795 923 73) verschweißt Berstdruck 2.800 bar Transportbox (232 719 40) <p>Vewendungszweck: Siehe 232 614 40</p>	<p>High-power hydraulic drive wrench & aggregate, set Torque range 390 - 3,934 Nm</p> <p>The set contains:</p> <ul style="list-style-type: none"> High-power hydraulic drive wrench (232 614 40) 1" drive incl. reaction arm High pressure hydraulic aggregate (793 375 73) Supply voltage 230 V 3-stages-delivery Setting range up to 700 bar incl. digital manometer and oil, incl. 5 m remote control incl. safety couplings High pressure twin-hose NS 6 x 5 m (795 923 73) Welded Burst pressure 2,800 bar Transportation box (232 719 40) <p>Recommended range of use: Refer to 232 614 40</p>	  
232 758 40	<p>Hydraulischer Kraftschrauber mit Hydraulikaggregat als Satz Drehmoment 741 - 7,402 Nm</p> <p>Der Satz beinhaltet:</p> <ul style="list-style-type: none"> Hydraulischer Kraftschrauber (232 615 40) 1 ½" Antrieb inklusive Reaktionsarm Hochdruck Hydraulikaggregat (793 375 73) 230 V Versorgungsspannung 3-Stufen Förderleistung Druckverstellung bis 700 bar inkl. Digitalmanometer und Öl inkl. Fernbedienung mit 5 m Kabel Inkl. Sicherheitskupplungen Hochdruckschlauch NW 6 x 5000 (795 923 73) verschweißt Berstdruck 2.800 bar Transportbox (232 719 40) <p>Vewendungszweck: Siehe 232 615 40</p>	<p>High-power hydraulic drive wrench & aggregate, set Torque range 741 - 7,402 Nm</p> <p>The set contains:</p> <ul style="list-style-type: none"> High-power hydraulic drive wrench (232 615 40) 1 ½" drive incl. reaction arm High pressure hydraulic aggregate (793 375 73) Supply voltage 230 V 3-stages-delivery Setting range up to 700 bar incl. digital manometer and oil, incl. 5 m remote control incl. safety couplings High pressure twin-hose NS 6 x 5 m (795 923 73) Welded Burst pressure 2,800 bar Transportation box (232 719 40) <p>Recommended range of use: Refer to 232 615 40</p>	  

Werkzeuge: Tools:	Kraftschrauber und Zubehör Power Tools	Gruppe / Section 2
		Seite / Page 15

ET-Nr. / Part-No.	Beschreibung	Description	
----------------------	--------------	-------------	---

Ausgabe: 11. November 2011
Release: November 11, 2011

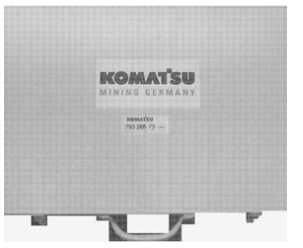
793 265 73	<p>Reparaturset für YAZAKI-Stecker</p> <p>Der Satz beinhaltet:</p> <table border="1"> <thead> <tr> <th>Anz.</th> <th>Beschreibung</th> </tr> </thead> <tbody> <tr><td>055 100 40</td><td>10 Kabelschuh 2,5 mm² / ø5 mm</td></tr> <tr><td>055 102 40</td><td>10 Kabelschuh 1,5-2,5 mm²</td></tr> <tr><td>055 103 40</td><td>10 Kabelschuh 0,5-1 mm²</td></tr> <tr><td>055 104 40</td><td>10 Kabelschuh 0,5-1 mm² / ø4 mm</td></tr> <tr><td>055 105 40</td><td>10 Kabelschuh 4-6 mm² / ø6 mm</td></tr> <tr><td>055 107 40</td><td>10 Kabelschuh 1 mm² / ø5 mm</td></tr> <tr><td>055 108 40</td><td>10 Kabelschuh 4,9 mm² / ø5 mm</td></tr> <tr><td>055 109 40</td><td>10 Kabelschuh 12,5 mm² / ø8,5mm</td></tr> <tr><td>055 110 40</td><td>10 Kabelschuh 3 mm² / ø6,5 mm</td></tr> <tr><td>055 111 40</td><td>10 Kabelschuh 12,5 mm² / ø4 mm</td></tr> <tr><td>055 112 40</td><td>10 Kabelschuh 4,9 mm² / ø2 mm</td></tr> <tr><td>055 114 40</td><td>10 Kabelschuh 2,5 mm² / ø6,3 mm</td></tr> <tr><td>055 115 40</td><td>10 Steckmuffe 3 mm²</td></tr> <tr><td>055 120 40</td><td>10 Kabelschuh 1 mm²</td></tr> <tr><td>055 125 40</td><td>10 Anschlussstift 7 mm²</td></tr> <tr><td>055 131 40</td><td>10 Steckmuffe 4-6mm</td></tr> <tr><td>055 140 40</td><td>10 Stoßverbinder 0,5-1 mm²</td></tr> <tr><td>055 141 40</td><td>10 Stoßverbinder 1,5-2,5 mm²</td></tr> <tr><td>055 142 40</td><td>10 Stoßverbinder 4-6 mm²</td></tr> <tr><td>056 070 40</td><td>50 Kabeltülle 1,0-2,5 mm²</td></tr> <tr><td>056 071 40</td><td>50 Kabeltülle 2,5-6 mm²</td></tr> <tr><td>056 072 40</td><td>10 Kabeltülle 4 mm²</td></tr> <tr><td>202 973 40</td><td>10 Steckverteiler</td></tr> <tr><td>256 084 40</td><td>10 Kabelschuh 1,75 mm² / ø6,5mm</td></tr> <tr><td>269 078 40</td><td>10 Kabeltülle ø6 mm</td></tr> <tr><td>323 725 40</td><td>10 Kabelschuh ø4 mm / ø3 mm</td></tr> <tr><td>323 961 40</td><td>10 Steckhülse 6,3 x 0,8 mm</td></tr> <tr><td>324 484 40</td><td>10 Kabeltülle 6 mm²</td></tr> <tr><td>440 109 40</td><td>10 Steckmuffe ø4 mm</td></tr> <tr><td>440 151 99</td><td>10 Steckmuffe 6,3 mm</td></tr> <tr><td>500 090 98</td><td>50 Aderendhülse 0,75 mm</td></tr> <tr><td>635 042 40</td><td>50 Aderendhülse 1,5 mm</td></tr> <tr><td>907 577 40</td><td>10 Steckverteiler</td></tr> <tr><td>891 031 40</td><td>2 Stecker</td></tr> <tr><td>891 030 40</td><td>2 Stecker</td></tr> <tr><td>891 039 40</td><td>2 Stecker</td></tr> <tr><td>891 040 40</td><td>2 Stecker</td></tr> <tr><td>891 038 40</td><td>2 Stecker</td></tr> <tr><td>891 032 40</td><td>2 Stecker</td></tr> <tr><td>464 814</td><td>1 Isolierband</td></tr> <tr><td>057 296 40</td><td>1 Steckverbinder</td></tr> <tr><td>898 680 40</td><td>2 Relais kpl.</td></tr> <tr><td>898 681 40</td><td>2 Relais kpl.</td></tr> <tr><td>792 104 73</td><td>100 Kabelbinder 200 x 4,8</td></tr> <tr><td>792 105 40</td><td>100 Kabelbinder</td></tr> <tr><td>792 106 40</td><td>100 Kabelbinder</td></tr> <tr><td>966 661</td><td>1 Quetschzange</td></tr> </tbody> </table>	Anz.	Beschreibung	055 100 40	10 Kabelschuh 2,5 mm ² / ø5 mm	055 102 40	10 Kabelschuh 1,5-2,5 mm ²	055 103 40	10 Kabelschuh 0,5-1 mm ²	055 104 40	10 Kabelschuh 0,5-1 mm ² / ø4 mm	055 105 40	10 Kabelschuh 4-6 mm ² / ø6 mm	055 107 40	10 Kabelschuh 1 mm ² / ø5 mm	055 108 40	10 Kabelschuh 4,9 mm ² / ø5 mm	055 109 40	10 Kabelschuh 12,5 mm ² / ø8,5mm	055 110 40	10 Kabelschuh 3 mm ² / ø6,5 mm	055 111 40	10 Kabelschuh 12,5 mm ² / ø4 mm	055 112 40	10 Kabelschuh 4,9 mm ² / ø2 mm	055 114 40	10 Kabelschuh 2,5 mm ² / ø6,3 mm	055 115 40	10 Steckmuffe 3 mm ²	055 120 40	10 Kabelschuh 1 mm ²	055 125 40	10 Anschlussstift 7 mm ²	055 131 40	10 Steckmuffe 4-6mm	055 140 40	10 Stoßverbinder 0,5-1 mm ²	055 141 40	10 Stoßverbinder 1,5-2,5 mm ²	055 142 40	10 Stoßverbinder 4-6 mm ²	056 070 40	50 Kabeltülle 1,0-2,5 mm ²	056 071 40	50 Kabeltülle 2,5-6 mm ²	056 072 40	10 Kabeltülle 4 mm ²	202 973 40	10 Steckverteiler	256 084 40	10 Kabelschuh 1,75 mm ² / ø6,5mm	269 078 40	10 Kabeltülle ø6 mm	323 725 40	10 Kabelschuh ø4 mm / ø3 mm	323 961 40	10 Steckhülse 6,3 x 0,8 mm	324 484 40	10 Kabeltülle 6 mm ²	440 109 40	10 Steckmuffe ø4 mm	440 151 99	10 Steckmuffe 6,3 mm	500 090 98	50 Aderendhülse 0,75 mm	635 042 40	50 Aderendhülse 1,5 mm	907 577 40	10 Steckverteiler	891 031 40	2 Stecker	891 030 40	2 Stecker	891 039 40	2 Stecker	891 040 40	2 Stecker	891 038 40	2 Stecker	891 032 40	2 Stecker	464 814	1 Isolierband	057 296 40	1 Steckverbinder	898 680 40	2 Relais kpl.	898 681 40	2 Relais kpl.	792 104 73	100 Kabelbinder 200 x 4,8	792 105 40	100 Kabelbinder	792 106 40	100 Kabelbinder	966 661	1 Quetschzange	<p>Electric kit for YAZAKI connectors</p> <p>Contains:</p> <table border="1"> <thead> <tr> <th>Qty.</th> <th>Description</th> </tr> </thead> <tbody> <tr><td>10</td><td>Cable lug 2.5 mm² / ø5mm</td></tr> <tr><td>10</td><td>Cable lug 1.5-2.5 mm²</td></tr> <tr><td>10</td><td>Cable lug 0.5-1 mm²</td></tr> <tr><td>10</td><td>Cable lug 0.5-1mm² / ø4 mm</td></tr> <tr><td>10</td><td>Cable lug 4-6 mm² / ø6 mm</td></tr> <tr><td>10</td><td>Cable lug 1 mm² / ø5 mm</td></tr> <tr><td>10</td><td>Cable lug 4.9 mm² / ø5 mm</td></tr> <tr><td>10</td><td>Cable lug 12.5 mm² / ø8.5 mm</td></tr> <tr><td>10</td><td>Cable lug 3 mm² / ø6.5 mm</td></tr> <tr><td>10</td><td>Cable lug 12.5 mm² / ø4 mm</td></tr> <tr><td>10</td><td>Cable lug 4.9 mm² / ø2 mm</td></tr> <tr><td>10</td><td>Cable lug 2.5 mm² / ø6.3 mm</td></tr> <tr><td>10</td><td>Plug-in sleeve 3mm²</td></tr> <tr><td>10</td><td>Cable lug 1 mm²</td></tr> <tr><td>10</td><td>Pin 7 mm²</td></tr> <tr><td>10</td><td>Plug-in sleeve 4-6 mm</td></tr> <tr><td>10</td><td>Connection 0.5-1 mm²</td></tr> <tr><td>10</td><td>Connection 1.5-2.5 mm²</td></tr> <tr><td>10</td><td>Connection 4-6 mm²</td></tr> <tr><td>50</td><td>Cable sleeve 1.0-2.5 mm</td></tr> <tr><td>50</td><td>Cable sleeve 2.5-6 mm</td></tr> <tr><td>10</td><td>Cable sleeve 4 mm</td></tr> <tr><td>10</td><td>Distributor</td></tr> <tr><td>10</td><td>Cable lug 1.75 mm² / ø6.5 mm</td></tr> <tr><td>10</td><td>Cable sleeve ø6mm</td></tr> <tr><td>10</td><td>Cable lug ø4 mm / ø3mm</td></tr> <tr><td>10</td><td>Sleeve 6.3 x 0.8mm</td></tr> <tr><td>10</td><td>Cable sleeve 6mm²</td></tr> <tr><td>10</td><td>Plug-in sleeve ø4 mm</td></tr> <tr><td>10</td><td>Plug-in sleeve 6.3 mm</td></tr> <tr><td>50</td><td>Cable sleeve 0.75 mm</td></tr> <tr><td>50</td><td>Cable sleeve 1.5 mm</td></tr> <tr><td>10</td><td>Distributor</td></tr> <tr><td>2</td><td>Plug</td></tr> <tr><td>2</td><td>Plug</td></tr> <tr><td>2</td><td>Plug</td></tr> <tr><td>2</td><td>Plug</td></tr> <tr><td>2</td><td>Plug</td></tr> <tr><td>2</td><td>Plug</td></tr> <tr><td>1</td><td>Insulating tape</td></tr> <tr><td>1</td><td>Connection</td></tr> <tr><td>2</td><td>Relay assy</td></tr> <tr><td>2</td><td>Relay assy</td></tr> <tr><td>100</td><td>Cable strap 200 x 4.8</td></tr> <tr><td>100</td><td>Cable strap</td></tr> <tr><td>100</td><td>Cable strap</td></tr> <tr><td>1</td><td>Squeezing pliers</td></tr> </tbody> </table>	Qty.	Description	10	Cable lug 2.5 mm ² / ø5mm	10	Cable lug 1.5-2.5 mm ²	10	Cable lug 0.5-1 mm ²	10	Cable lug 0.5-1mm ² / ø4 mm	10	Cable lug 4-6 mm ² / ø6 mm	10	Cable lug 1 mm ² / ø5 mm	10	Cable lug 4.9 mm ² / ø5 mm	10	Cable lug 12.5 mm ² / ø8.5 mm	10	Cable lug 3 mm ² / ø6.5 mm	10	Cable lug 12.5 mm ² / ø4 mm	10	Cable lug 4.9 mm ² / ø2 mm	10	Cable lug 2.5 mm ² / ø6.3 mm	10	Plug-in sleeve 3mm ²	10	Cable lug 1 mm ²	10	Pin 7 mm ²	10	Plug-in sleeve 4-6 mm	10	Connection 0.5-1 mm ²	10	Connection 1.5-2.5 mm ²	10	Connection 4-6 mm ²	50	Cable sleeve 1.0-2.5 mm	50	Cable sleeve 2.5-6 mm	10	Cable sleeve 4 mm	10	Distributor	10	Cable lug 1.75 mm ² / ø6.5 mm	10	Cable sleeve ø6mm	10	Cable lug ø4 mm / ø3mm	10	Sleeve 6.3 x 0.8mm	10	Cable sleeve 6mm ²	10	Plug-in sleeve ø4 mm	10	Plug-in sleeve 6.3 mm	50	Cable sleeve 0.75 mm	50	Cable sleeve 1.5 mm	10	Distributor	2	Plug	2	Plug	2	Plug	2	Plug	2	Plug	2	Plug	1	Insulating tape	1	Connection	2	Relay assy	2	Relay assy	100	Cable strap 200 x 4.8	100	Cable strap	100	Cable strap	1	Squeezing pliers	 
Anz.	Beschreibung																																																																																																																																																																																																		
055 100 40	10 Kabelschuh 2,5 mm ² / ø5 mm																																																																																																																																																																																																		
055 102 40	10 Kabelschuh 1,5-2,5 mm ²																																																																																																																																																																																																		
055 103 40	10 Kabelschuh 0,5-1 mm ²																																																																																																																																																																																																		
055 104 40	10 Kabelschuh 0,5-1 mm ² / ø4 mm																																																																																																																																																																																																		
055 105 40	10 Kabelschuh 4-6 mm ² / ø6 mm																																																																																																																																																																																																		
055 107 40	10 Kabelschuh 1 mm ² / ø5 mm																																																																																																																																																																																																		
055 108 40	10 Kabelschuh 4,9 mm ² / ø5 mm																																																																																																																																																																																																		
055 109 40	10 Kabelschuh 12,5 mm ² / ø8,5mm																																																																																																																																																																																																		
055 110 40	10 Kabelschuh 3 mm ² / ø6,5 mm																																																																																																																																																																																																		
055 111 40	10 Kabelschuh 12,5 mm ² / ø4 mm																																																																																																																																																																																																		
055 112 40	10 Kabelschuh 4,9 mm ² / ø2 mm																																																																																																																																																																																																		
055 114 40	10 Kabelschuh 2,5 mm ² / ø6,3 mm																																																																																																																																																																																																		
055 115 40	10 Steckmuffe 3 mm ²																																																																																																																																																																																																		
055 120 40	10 Kabelschuh 1 mm ²																																																																																																																																																																																																		
055 125 40	10 Anschlussstift 7 mm ²																																																																																																																																																																																																		
055 131 40	10 Steckmuffe 4-6mm																																																																																																																																																																																																		
055 140 40	10 Stoßverbinder 0,5-1 mm ²																																																																																																																																																																																																		
055 141 40	10 Stoßverbinder 1,5-2,5 mm ²																																																																																																																																																																																																		
055 142 40	10 Stoßverbinder 4-6 mm ²																																																																																																																																																																																																		
056 070 40	50 Kabeltülle 1,0-2,5 mm ²																																																																																																																																																																																																		
056 071 40	50 Kabeltülle 2,5-6 mm ²																																																																																																																																																																																																		
056 072 40	10 Kabeltülle 4 mm ²																																																																																																																																																																																																		
202 973 40	10 Steckverteiler																																																																																																																																																																																																		
256 084 40	10 Kabelschuh 1,75 mm ² / ø6,5mm																																																																																																																																																																																																		
269 078 40	10 Kabeltülle ø6 mm																																																																																																																																																																																																		
323 725 40	10 Kabelschuh ø4 mm / ø3 mm																																																																																																																																																																																																		
323 961 40	10 Steckhülse 6,3 x 0,8 mm																																																																																																																																																																																																		
324 484 40	10 Kabeltülle 6 mm ²																																																																																																																																																																																																		
440 109 40	10 Steckmuffe ø4 mm																																																																																																																																																																																																		
440 151 99	10 Steckmuffe 6,3 mm																																																																																																																																																																																																		
500 090 98	50 Aderendhülse 0,75 mm																																																																																																																																																																																																		
635 042 40	50 Aderendhülse 1,5 mm																																																																																																																																																																																																		
907 577 40	10 Steckverteiler																																																																																																																																																																																																		
891 031 40	2 Stecker																																																																																																																																																																																																		
891 030 40	2 Stecker																																																																																																																																																																																																		
891 039 40	2 Stecker																																																																																																																																																																																																		
891 040 40	2 Stecker																																																																																																																																																																																																		
891 038 40	2 Stecker																																																																																																																																																																																																		
891 032 40	2 Stecker																																																																																																																																																																																																		
464 814	1 Isolierband																																																																																																																																																																																																		
057 296 40	1 Steckverbinder																																																																																																																																																																																																		
898 680 40	2 Relais kpl.																																																																																																																																																																																																		
898 681 40	2 Relais kpl.																																																																																																																																																																																																		
792 104 73	100 Kabelbinder 200 x 4,8																																																																																																																																																																																																		
792 105 40	100 Kabelbinder																																																																																																																																																																																																		
792 106 40	100 Kabelbinder																																																																																																																																																																																																		
966 661	1 Quetschzange																																																																																																																																																																																																		
Qty.	Description																																																																																																																																																																																																		
10	Cable lug 2.5 mm ² / ø5mm																																																																																																																																																																																																		
10	Cable lug 1.5-2.5 mm ²																																																																																																																																																																																																		
10	Cable lug 0.5-1 mm ²																																																																																																																																																																																																		
10	Cable lug 0.5-1mm ² / ø4 mm																																																																																																																																																																																																		
10	Cable lug 4-6 mm ² / ø6 mm																																																																																																																																																																																																		
10	Cable lug 1 mm ² / ø5 mm																																																																																																																																																																																																		
10	Cable lug 4.9 mm ² / ø5 mm																																																																																																																																																																																																		
10	Cable lug 12.5 mm ² / ø8.5 mm																																																																																																																																																																																																		
10	Cable lug 3 mm ² / ø6.5 mm																																																																																																																																																																																																		
10	Cable lug 12.5 mm ² / ø4 mm																																																																																																																																																																																																		
10	Cable lug 4.9 mm ² / ø2 mm																																																																																																																																																																																																		
10	Cable lug 2.5 mm ² / ø6.3 mm																																																																																																																																																																																																		
10	Plug-in sleeve 3mm ²																																																																																																																																																																																																		
10	Cable lug 1 mm ²																																																																																																																																																																																																		
10	Pin 7 mm ²																																																																																																																																																																																																		
10	Plug-in sleeve 4-6 mm																																																																																																																																																																																																		
10	Connection 0.5-1 mm ²																																																																																																																																																																																																		
10	Connection 1.5-2.5 mm ²																																																																																																																																																																																																		
10	Connection 4-6 mm ²																																																																																																																																																																																																		
50	Cable sleeve 1.0-2.5 mm																																																																																																																																																																																																		
50	Cable sleeve 2.5-6 mm																																																																																																																																																																																																		
10	Cable sleeve 4 mm																																																																																																																																																																																																		
10	Distributor																																																																																																																																																																																																		
10	Cable lug 1.75 mm ² / ø6.5 mm																																																																																																																																																																																																		
10	Cable sleeve ø6mm																																																																																																																																																																																																		
10	Cable lug ø4 mm / ø3mm																																																																																																																																																																																																		
10	Sleeve 6.3 x 0.8mm																																																																																																																																																																																																		
10	Cable sleeve 6mm ²																																																																																																																																																																																																		
10	Plug-in sleeve ø4 mm																																																																																																																																																																																																		
10	Plug-in sleeve 6.3 mm																																																																																																																																																																																																		
50	Cable sleeve 0.75 mm																																																																																																																																																																																																		
50	Cable sleeve 1.5 mm																																																																																																																																																																																																		
10	Distributor																																																																																																																																																																																																		
2	Plug																																																																																																																																																																																																		
2	Plug																																																																																																																																																																																																		
2	Plug																																																																																																																																																																																																		
2	Plug																																																																																																																																																																																																		
2	Plug																																																																																																																																																																																																		
2	Plug																																																																																																																																																																																																		
1	Insulating tape																																																																																																																																																																																																		
1	Connection																																																																																																																																																																																																		
2	Relay assy																																																																																																																																																																																																		
2	Relay assy																																																																																																																																																																																																		
100	Cable strap 200 x 4.8																																																																																																																																																																																																		
100	Cable strap																																																																																																																																																																																																		
100	Cable strap																																																																																																																																																																																																		
1	Squeezing pliers																																																																																																																																																																																																		

Werkzeuge: Tools:	Reparatursets für Kabel und Stecker Repair Sets for Wiring & Connectors	Gruppe / Section 7
		Seite / Page 39

- Check the outer diameter of the new swing circle top surface and compare with the outer diameter of the factory machined surface of the superstructure.
- Remove the shoulder by machining if necessary.

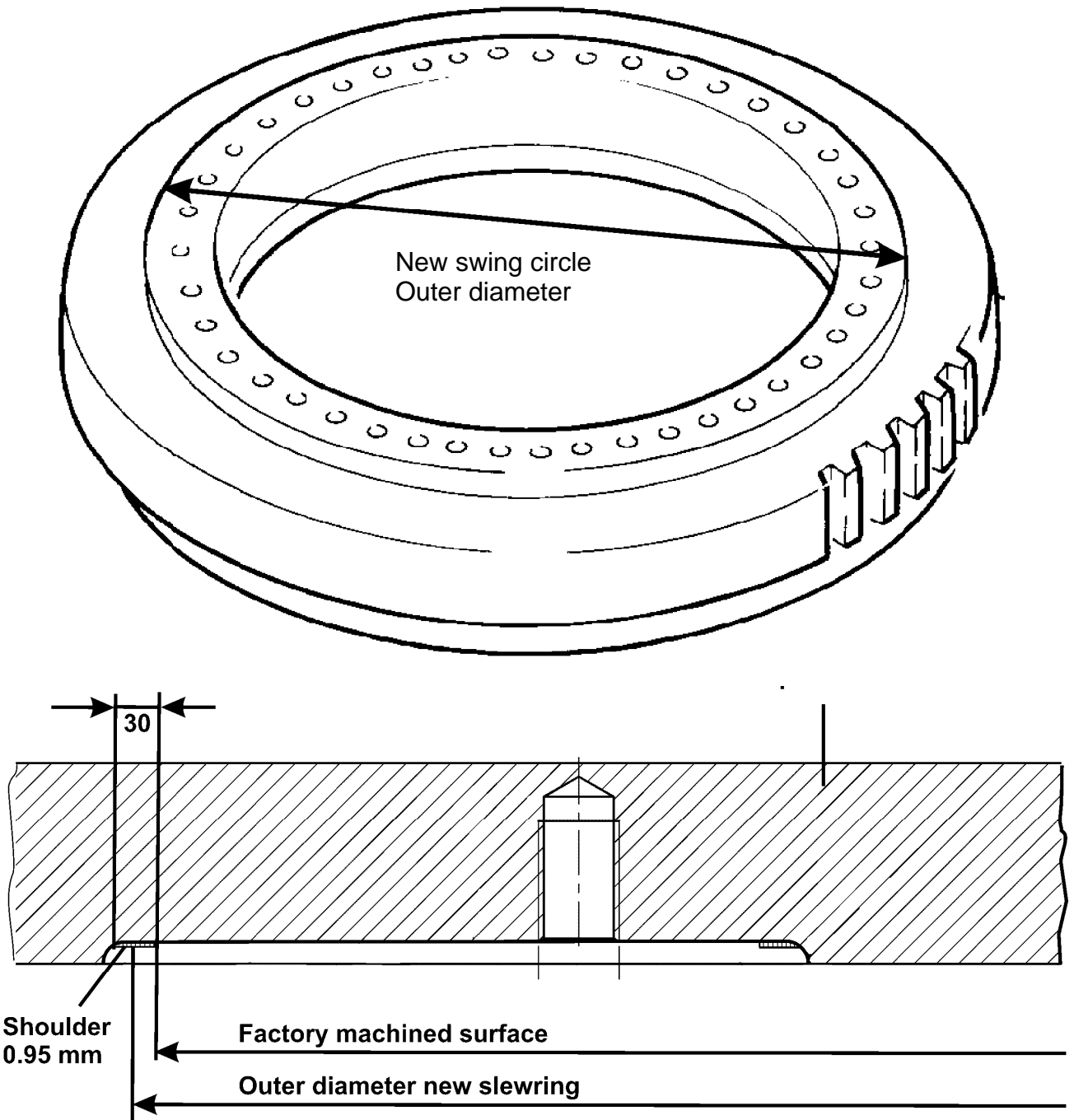

Illustration 2



- Such a shoulder exists only at some older shovels.

Drill holes on a vertical boring machine. The sprocket has to be on top. Use Shell counterbores of high speed steel.

Model	Holes for the shearing pins
H 241	4 x 43.5 mm
H 285/ H 285S	6 x 51.5 mm
PC4000	6 x 51.5 mm
H 485/ H485S	8 x 56.5 mm
H 685S/SX	8 x 56.5 mm
H 655/ PC8000	8 x 56.5 mm

Ream the holes for the shearing pins.

Model	Holes for the shearing pins
H 241	4 x 44 H7
H 285/ H 285S	6 x 52 H7
PC4000	6 x 52 H7
H 485/ H485S	8 x 57 H7
H 685S/SX	8 x 57 H7
H 655/ PC8000	8 x 57 H7

After reaming bur the holes carefully.

5. Preparing the shearing pins

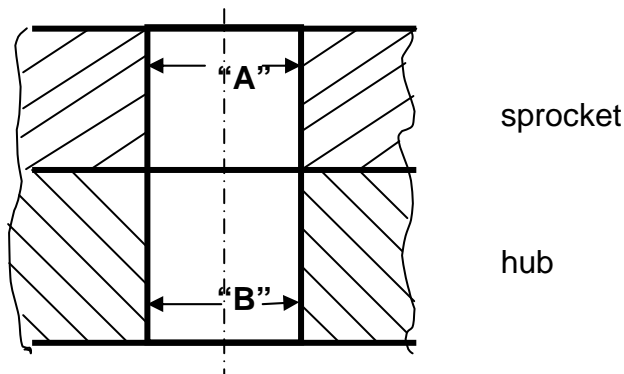

By means of a 3 point inside micrometer measure the diameter "A" and "B" at the spots as shown in the illustration.

Add 0.04 mm to the larger diameter and grind the oversize shearing pin to this dimension.

Repeat this procedure separately for all pins.

Example:

"A" = 57.01 mm

"B" = 57.02 mm

"B" is bigger. → The diameter of the pin has to be :

$$\begin{array}{r}
 57.02 \text{ mm} \\
 + 0.04 \text{ mm} \\
 \hline
 = \underline{\underline{57.06 \text{ mm}}}
 \end{array}$$

Shearing pins have to be deep-frozen by using liquid nitrogen (-196°C/-320°F and pushed into the reamed holes.

PARTS & SERVICE NEWS

REF NO.

AH01531A

DATE

06122002

Page 1 of 9

This PARTS & SERVICE NEWS supersedes the previous issues No. 21-426; 21-549 and AH01531 which should be discarded.

SUBJECT: Hydraulic accumulators – testing and refilling

PURPOSE: Regular check

APPLICATION: All types

FAILURE CODE: 307EPB; 6347PB

DESCRIPTION:

The testing and refilling of the hydraulic accumulators have to be performed by testing- and refilling device Part no. 761 520 73.

When ordering this particular device, please always indicate country of destination.

1. Testing of existing gas pressure at piston and diaphragm accumulators

For testing of existing gas pressure at bladder accumulators, refer to page 7 – 9.

- Stop engine.
- Allow pressure relief of the system to be checked.
- Remove protective cap from accumulator.
- Unscrew a union of the feeding line in order to allow the hydraulic oil to pour out.

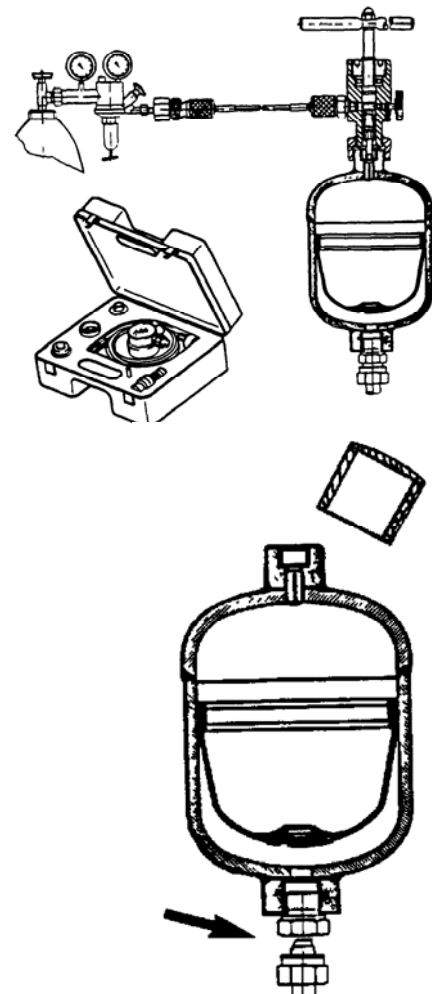

PARTS & SERVICE NEWS

REF NO.

AH03506b

DATE

October 25, 2003

Page 1 of 5

This PARTS & SERVICE NEWS supersedes the previous issue AH03506a which should be discarded.

SUBJECT: Hydraulic oil cooler and water cooler fan bearings

PURPOSE: Replacement of the bearings

APPLICATION: PC4000; PC5500; PC8000

FAILURE CODE: 0373CA

DESCRIPTION:

Two types of bearing units are used for the cooler fans at the above mentioned excavator models:

1. Grease lubricated bearings

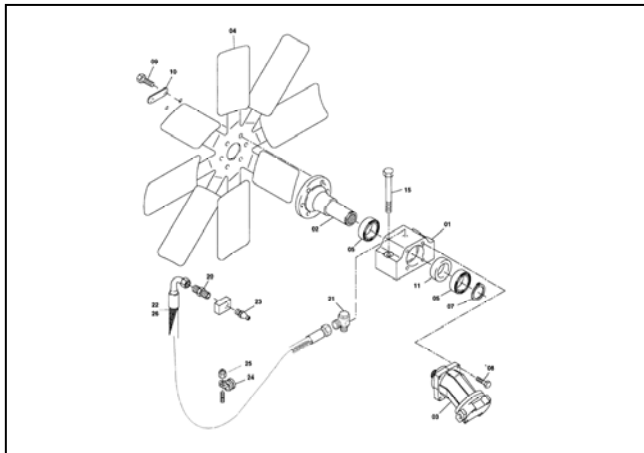

2. Gear oil lubricated bearings

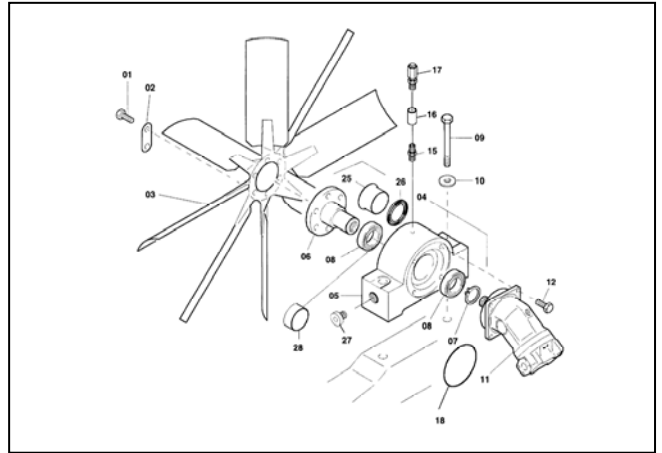

- We recommend to replace these bearings to avoid consequential damages according to the following table:

Bearing unit	Replacing time after:
Grease lubricated bearings	8 000 working hours
Gear oil lubricated bearings	10 000 working hours *

* or if damage or a leak has occurred.



- The hydraulic motors for the fans should be replaced preventively every 10.000 working hours.

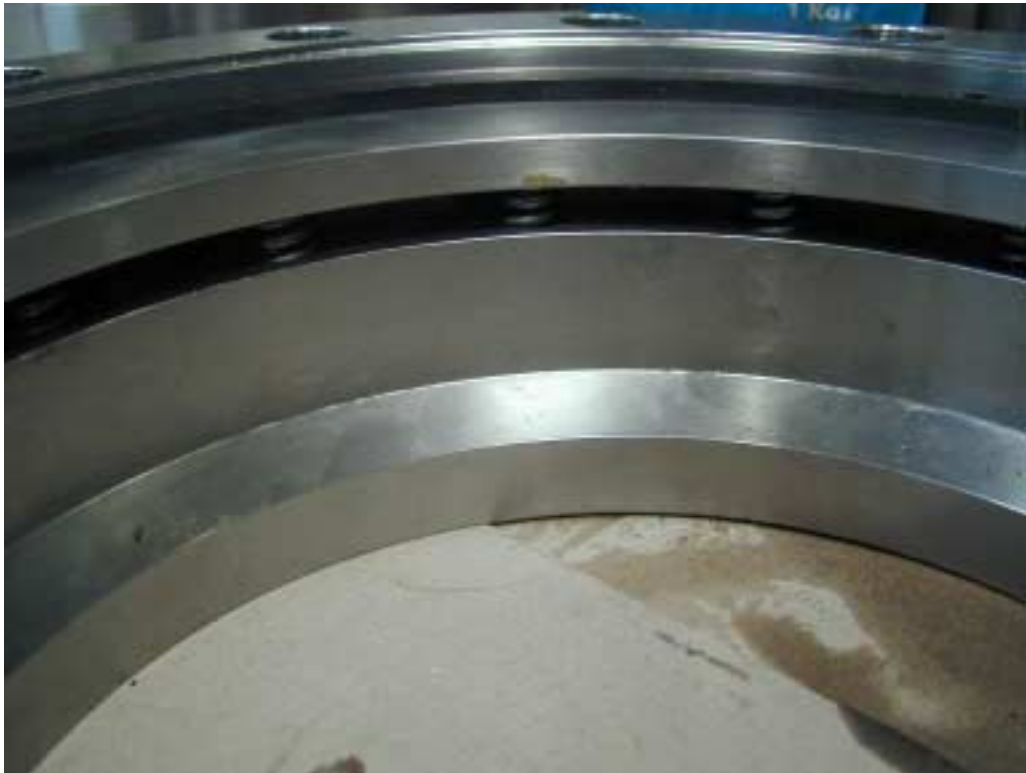

5.2.3 Welding the bosses

The weld surface must be clean and free of any contamination that might prevent a good weld. Follow the preheat interweld and post heat guidelines below.

Summary of Welding Specifications

- Electrodes: E7016 or E7018 low hydrogen (keep dry!)
- Wires: E70T-5, E71T-1, or E70T-1 with CO 2 gas.
- Preheat: 200°F/95°C (350-400°F/175-205°C if air temperature is 40°F/5°C or lower.)
- Interpass: Maintain interpass temperature less than 500°F/260°C.
- Postheat: If air temperature is 40°F or lower, postheat 350-400°F, then let air cool.
- Remove slag after each pass and peen each bead.

Weld the boss to the lip. Make sure that the boss is shimmed, so that the height of the boss will be correct after welding.

Weld area (A) completely before welding areas (B) & (C).

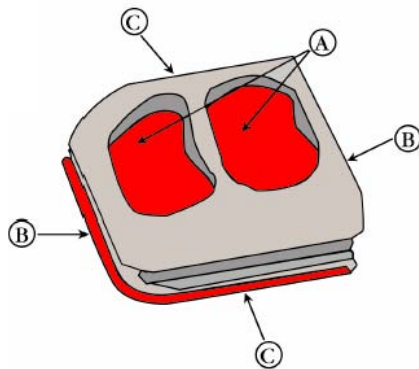

Welding Guide

Weld Location	(A)	(B)	(C)
Boss	Depth of weld plug holes mm/in	Size of fillet weld-on ends mm/in	Size of fillet weld-on ends mm/in
TAB	Plug Weld 10/.38	Fillet 10/.38	Fillet 3/.19
TBB	Plug Weld 13/.50	Fillet 13/.50	Fillet 6/.25
TCB	Plug Weld 16/.62	Fillet 13/.50	Fillet 6/.25

5.3 Inspecting Worn Shrouds

Toplok shrouds protect the bucket lip and wings from abrasive wear. Use of ESCO 12S abrasion resistant alloy assures long life before change out.

- Periodic inspection should be made to determine when to replace a shroud.
- Monitor high wear surfaces of the Toplok shroud for wear.
- Special “wear indicators” are special panels that will open up to alert the user of the need for changing shrouds.

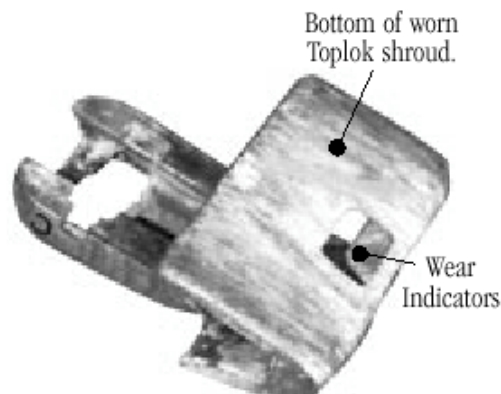

14.2.11 Settings (No. 4.8.1 – No. 4.8.10)

Other Settings 2/2
(No. 4.8.4)

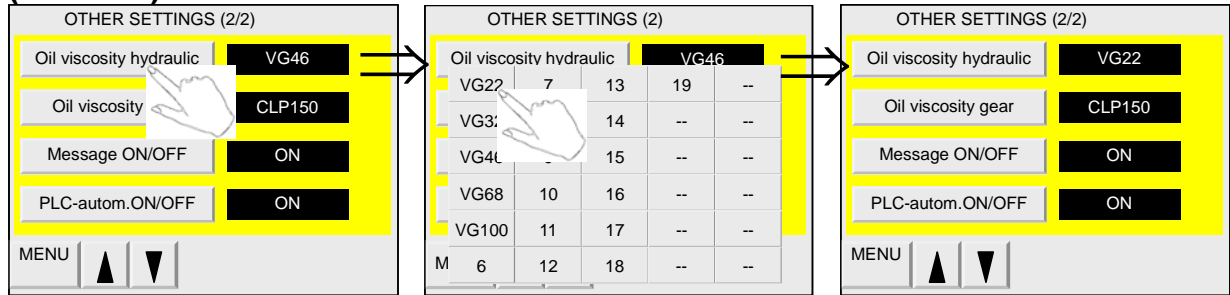

Hydraulic oil selector button:
now

When the selection menu appears,
select the required hydraulic oil.

The selected hydraulic oil is
displayed.

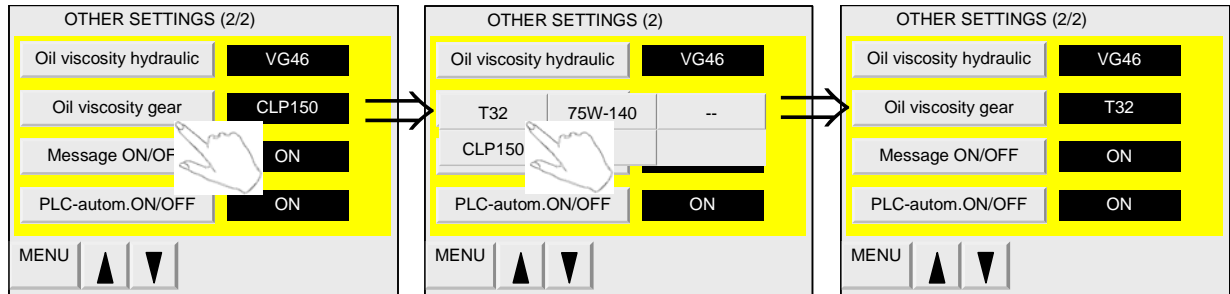

PTO - gear oil selector button:

When the selection menu appears,
select the required gear oil.

The selected gear oil is now
displayed.

Select the required oil out of the table from the specific flowchart.

Temperatur Hydrauliköl temperature hydraulic oil												
Temperatur in °C temperature in °C	Viskosität nach ISO viscosity grade according to ISO											
	VG22	VG32	VG46	VG68	VG100	Harmony HVI 36	MOBIL DTE 16M	ESSO HE46	PANOLIN SYNTH 46	Shell Donax Dexron ATF	Biohyd SE-5 46	DEA Econa E46
TypNr. / type no.	1	2	3	4	5	6	7	8	9	10	11	12
T1 (1000 cSt)	-20	-14	-6	0	5	-22	-6	-16	-14	-22	-12	-15
T2 (100 cSt)	9	16	25	32	39	14	32	22	22	15	23	23
T3 (30 cSt)	32	41	50	58	67	44	62	54	52	46	51	55
T4 (10 cSt -5°C)	58	69	79	85	85	80	85	85	85	82	85	85

Temperatur Hydrauliköl temperature hydraulic oil									
Temperatur in °C temperature in °C	Viskosität nach ISO viscosity grade according to ISO								
	SUNVIS H/O 32	KAJO HEES 46	Shell Tellus Arctic Oil L32	PUINTOLUBRIC 822-300	AeroShell Fluid 4/41	Shell Tellus Oil T15	Shell Tellus Oil T46	.	.
TypNr. / type no.	13	14	15	16	17	18	19	.	.
T1 (1000 cSt)	-25	-15	-39	-14	-60	-27	-10	.	.
T2 (100 cSt)	12	23	-1	30	-20	-3	23	.	.
T3 (30 cSt)	42	55	38	67	6	21	53	.	.
T4 (10 cSt -5°C)	78	85	85	85	49	49	85	.	.

Temperatur Getriebeöl (TG) temperature gear oil (TG)			
Temperatur in °C temperature in °C	Ölsorte nach ISO kind of oil according to ISO		
	T32	CLP150	Hypoid Oil 75W-140
TypNr. / type no.	1	2	3
TG	60	95	95

Tabellen, Definitionen tables, definitions		Typ Ident-Nr. F. AM-Nr. Name Datum	
PC4000-6		E5705	
Ident-Nr.:		Format Blatt/Blätter	
915 277 40 c		A3 05/ .	

Datum	Name	Computererstellte Zeichnung (CAD)	Bau Nr.:
11-JUL-01	Sanders/Thermann	Ablaufdiagramm Flowchart	08153
Gepr.:			
Abt.:	8121.4		

Copyright reserved (Schutzvermerk DIN 34 beachten)

KOMATSU
MINING GERMANY

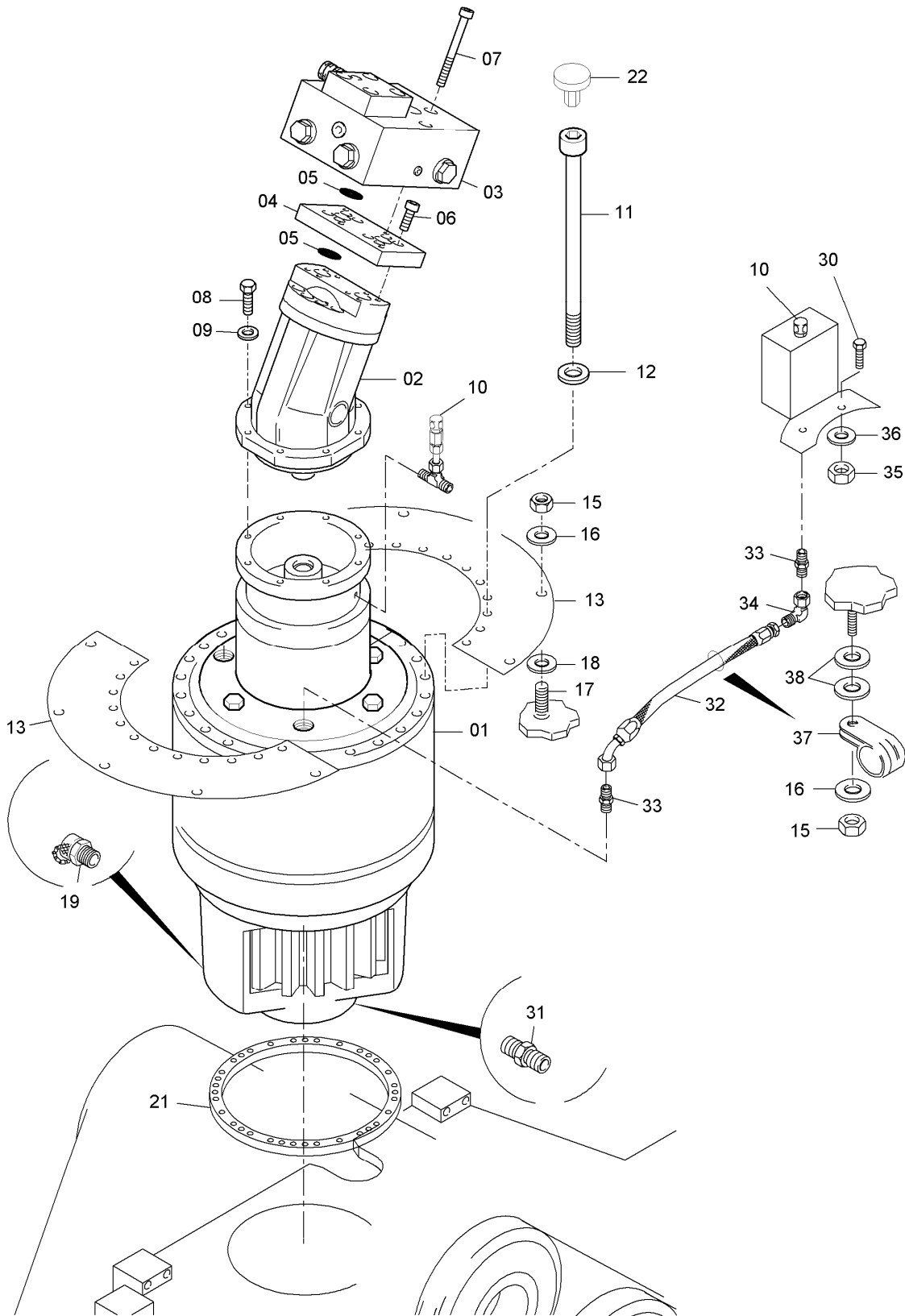

Illustration 3

7. Commissioning the air conditioning system



- **The air conditioning system will be delivered ex works completely filled with refrigerant and oil.**

7.1 General comments regarding commissioning of the air condition system

Absolute cleanliness must be ensured when installing or repairing an air conditioning system, as practically all the faults that arise can be traced back to the presence of dirt. As a cooling system is a closed system, any foreign bodies remain in the system until they cause a problem or even serious damage, which can then usually only be repaired at a great deal of trouble and expense. The system may nevertheless appear to start up and work perfectly normally. Damage caused by foreign bodies and dirt may not manifest itself for many months.

The continued proper functioning of the system depends on thorough and professional standards of work right from the outset. This entails proper storage and keeping all components closed and/or covered, through professional installation and assembly. In repair situations as well, right up to the scrupulous checking for leaks, cleaning, filling and commissioning of the system.

Professional and careful handling of tools, vacuum pumps, gauge manifold, etc. will provide many years of reliable system operation.

7.2 Checking for leaks

Following commissioning and repair work, every air conditioning or cooling system must be checked for leaks. Leaks not only means loss of refrigerant and hence reduced cooling capacity, they can also result in the ingress of moisture, which will eventually cause problems in the system.

A pressure test must first be performed following repair work and when a new system has been installed. Dry nitrogen 4.6 or 5.0 at 20 to max. 25 bar is used for the pressure test. This has the advantage that serious leaks or loose connections can be detected without the loss of any expensive refrigerant. In addition, the use of nitrogen purges (and hence cleans) the system as part of the pressure test. If the pressure in a closed system does not fall, it can be assumed that there is no leakage in the system.

5. Functional Test

After all adjustments are finished, do the following:

- a) Bleed all air from the system
- b) Place shutoff and pressure relief cocks into correct operating position.
- c) Connect pressure gauge to check point (M29.4).
- d) Start motors.
- e) Travel approx. 10 m with the shovel.
- f) Stop the motors.
- g) The pressure must drop to 35 bar.

If the pressure remains at a higher or lower pressure*, re-adjust the low pressure setting at the pressure increasing valve (141).



- * **The pressure may drop below 35 bar after a longer time. This is O.K. because of internal leakage.**

4. Conversion kits

4.1 Conversion kit PN 948 741 40 for modification to Wiggins VR300 system with the new connector VR316 (to 1136 l/min) for nozzle VR301

Pos.	Part No.	Qty.	Description	Drawing No.	Page
1*	948 217 40	1	Flange	948 711 40	13
2*	510 567 98	1	Breech block		
3*	533 992 99	3	Plate		
4*	533 989 99	3	Plate		

These parts are included in PN 948 741 40.

Pos.	Part No.	Qty.	Description	Drawing No.	Page
1	948 711 40		Drawing 948 711 40	948 741 40	14
2	948 719 40	1	Plate		
3	948 716 40	1	Cover		
4	948 775 40	1	Clamp holder		
5	948 706 40	1	Flange		
6	948 735 40	1	Holder		
7	948 738 40	3	Clamp holder		
8	948 742 40	1	Clamp holder		
9	948 724 40	2	Pipe bend		
10	518 415 98	1	Hose 3.200		
11	518 415 98	1	Hose 3.200		
12	941 280 40	1	Connector VR 316		
13	941 281 40	1	Receiver		
14	941 282 40	2	Vent valve		
15	941 283 40	1	Jet sensor		
16	518 392 98	1	Tube fitting		
17	518 393 98	1	Tube fitting		
18	941 289 40	1	Adapter		
19	941 534 40	1	Hose DN 76 x 2900		
20	941 535 40	1	Hose DN 76 x 3650		
21	518 482 98	1	Hose 12 x 2200		
22	518 483 98	1	Hose 06 x 2200		
23	500 399 98	1	Plate		
24	941 317 40	6	Clamp (two-piece)		
25	500 398 98	5	Plate		

The connection to the suction tank can be closed with the main gate valve (13) to prevent oil flow during repairs. This unit is controlled by the switch S31, it make sure a engine start is not possible with a closed main gate valve. Fault message „**Start blocked because of main Shut-Off (gate) valve**“ is displayed at the operators dash board.

The suction oil tank is a welded sheet-metal construction. The oil capacity of the suction oil tank and connecting pipe is together 102 liters.

A main screen filter in the line between main oil reservoir and suction tank protect the pumps for solid gross oil contamination. Additional screen filters in the aspiration line to each main pump protect the suction tank and the other pumps for contamination through a failed main pump.

WARNING

It is important to clean the screen filters in the pump suction line according to the maintenance manual and after a pump replacement.

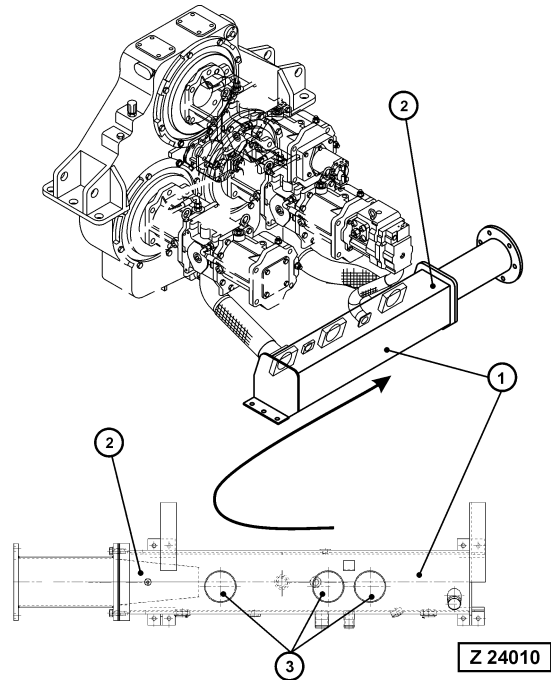

Legend for illustration Z 21500

- 1 Filter cover retainer
- 2 Filter cover with o-ring
- 3 Pre-tensioning spring
- 4 Retainer
- 5 Filter assembly
- 6 Filter pot with machined cover
- 7 Main filter element,
return filter = 10 micron filtration
leak oil filter = 3 micron filtration
- 8 Safety filter element
200 micron strainer filter, for return and leak oil
- 9 By pass-valve (opened at 2,3 bar)
- 9.1 Valve cone
- 9.2 Valve spring
- 9.3 O-ring
- 10 Profile gasket
- 11 Seal ring
- 12 Self locking nut
- 13 Self locking nut

Function:

The returning oil flows into the filter chamber (A) of the hydraulic reservoir. (The sketch shows one section only).

The chamber is divided in two sections; one section with 3 filters for the return oil and one for the leak oil. The four filters are all the same. The hydraulic oil enters the filter at the top and passes then on its way to the reservoir the filter-element (7). "Inside to outside filtration."

The filter element condition is monitored by pressure switches connected to the filter chambers.

As soon as the pressure inside the filter chamber reaches the set pressure of those switches due to the restriction of the filter element which is caused by foreign matters, the fault message „Return oil filter restricted“ or „Leak oil filter restricted“ is displayed at the operator's dash board The filter elements must be replaced. For safety pre-cautions the filter is equipped with a by-pass valve. As the filter chamber pressure increases the by-pass valve opens at 2.3 bar and protects the element from bursting.

But the oil flows not totally unfiltered into the reservoir because it must flow through the strainer (8).

3.4 RETURN OIL COLLECTOR TUBE WITH STRAINER

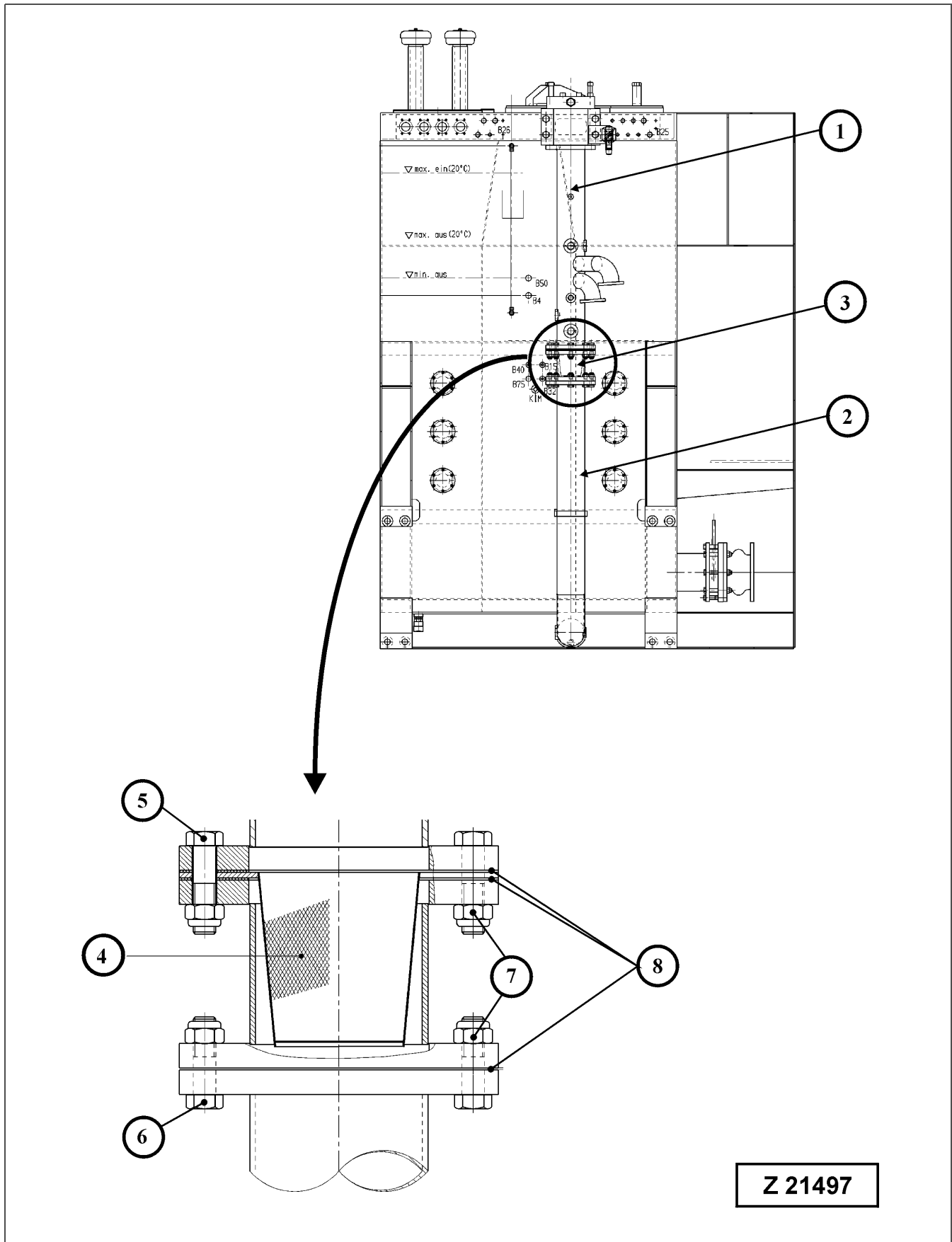

Fig. 3-4 Return oil collector tube

3.0 General lay out

Legend for illustration (Z 21494):

- | | |
|---------------|---|
| (1) | Filter cover retainer |
| (2) | Filter cover |
| (3) | Filter element |
| | (A) - Return oil filter - 10 µm |
| | (B) - Case drain filter - 3 µm |
| (4) | Man hole cover |
| (24) | Pressure switch B24 – monitors item (92.1) – (92.2) |
| (30) | Hydraulic oil level gauge |
| (41) | Main oil reservoir |
| (54) | Return oil collector tube with pressure check point M10 |
| (55) | Back pressure valve |
| (67) | Dust cap for item (77) |
| (77) | Oil drain, quick release coupling |
| (87) | Shut off valve with S31 (Gate valve) |
| (88) | Compensator |
| (92.1 + 92.2) | Breather filter |

The hydraulic oil tank is a welded sheet-metal construction.

The capacity is about 3700 litres. The tank contains four return oil filters (3-A) and one case drain filter (3-B).

The breather filter (92.1 + 92.2) cleans the air that streams into the tank.

The back pressure valve (55) and the pressure check point (M10) are located at the collector tube (54) for return oil.

The connection to the suction tank can be closed with the shut- off valve (87) to prevent oil flow during repairs on the hydraulic pumps. This unit is controlled by the switch S31, it makes sure a motor start is not possible with a closed shut-off valve. Fault message "Start blocked because of main Shut-Off (gate) valve" is displayed at the operators dash board.

3.7 Breather filter

Legend for illustration (Z 21501):

- (1) Nut
- (2) Cover
- (3) Filter element
- (4) Filter pot

A breather filter is installed to clean the air that streams into the tank any time the oil level decreases while extending attachment cylinders

The filter element condition is monitored by a vacuum type pressure switch (B24, 80mbar).



- **Refer to the maintenance manual, for further information**

CLICK HERE TO **DOWNLOAD** THE COMPLETE MANUAL

- Thank you very much for reading the preview of the manual.
- You can download the complete manual from: www.heydownloads.com by clicking the link below



- Please note: If there is no response to CLICKING the link, please download this PDF first and then click on it.

CLICK HERE TO **DOWNLOAD** THE COMPLETE MANUAL