

Shop Manual

MINI
EXCAVATOR

PC33E-6

SERIAL NUMBERS 2001 and up

Electric

KOMATSU

CLICK HERE TO **DOWNLOAD** THE COMPLETE MANUAL

- Thank you very much for reading the preview of the manual.
- You can download the complete manual from: www.heydownloads.com by clicking the link below



- Please note: If there is no response to CLICKING the link, please download this PDF first and then click on it.









CLICK HERE TO **DOWNLOAD** THE COMPLETE MANUAL

90 Circuit Diagrams

This section gives information for the overall hydraulic circuit diagrams and electric circuit diagrams.

Symbol

Important safety and quality parts are marked with the symbols that follow to use Shop Manual effectively.

Symbol	Item	Summary
	Danger	This symbol shows extremely high possibility of danger which will result in death or personal injury if it is not avoided.
	Warning	This symbol shows a potentially dangerous situation which will result in death or personal injury if it is not avoided.
	Caution	This symbol shows a potentially dangerous situation which will result in injury or property damage around the machine if it is not avoided.
	Weight	This symbol shows the weight of parts and components. Refer to this symbol when you handle heavy object for selection of the required equipment such as crane and lifting tools, and for what kind of working posture to take.
	Tightening torque	This symbol shows the tightening torque for parts which requires special care in assembly work.
	Lubrication	This symbol shows a lubrication point with adhesive, grease, or such in the assembly work.
	Oil and coolant	This symbol shows a point to supply oil, coolant, or such with the quantity.
	Drain	This symbol shows a point to drain oil, coolant, or such with the quantity.
	Safety	This symbol shows the work that requires special attention for the machine safety during the assembly work.

Signal Word

The signal word for NOTICE and REMARK shows the contents that follow.

Symbol	Item	Summary
NOTICE	Notice	If you do not obey the precaution of this signal word, the machine can have damage or the service life can be shortened.
REMARK	Remarks	Information shown in this signal word is useful to know.

Unit

International System of Units (SI) is used in this manual. For reference, the conventional units are given in { }.

Precautions When You Dispose of Waste Materials

To prevent environmental pollution, be very careful about the disposal of waste materials.

- Always drain the waste into containers such as cans, tanks. Never pour the waste into the ground, or to the river, sewage, sea or lake.
- When disposing of harmful substances such as oil, fuel, cooling water, solvents, filters, batteries, obey the applicable laws and regulations.

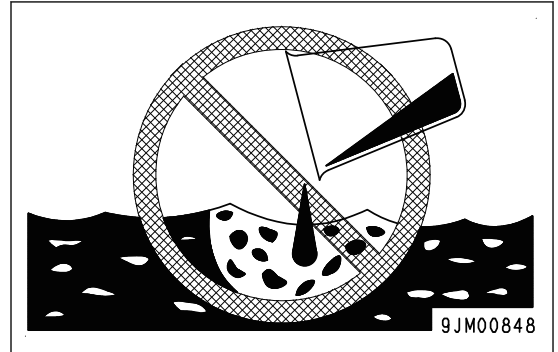

Some of the rubber and plastics generate harmful gases that can cause adverse effects on the human body when burned.

- Disposal of rubber, plastic, and other components (hoses, cables, harnesses, etc.) which contains rubber and plastics shall be entrusted to the processing contractor in accordance with applicable laws and regulations.

REMARK

- Put on the applicable protective equipment in response to the equipment for inspection and maintenance.
- For details about the protective equipment, see “Precautions for Inspection and Maintenance of High Voltage Parts”.

13. Remove the bracket (5).

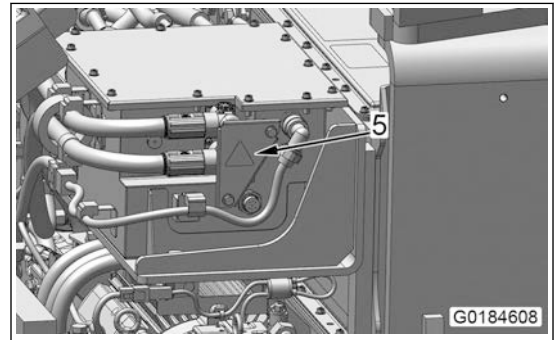

14. Disconnect the high voltage wiring (output cable) (6).

REMARK

Be careful not to let dirt attach to the connector at the removed wiring side.

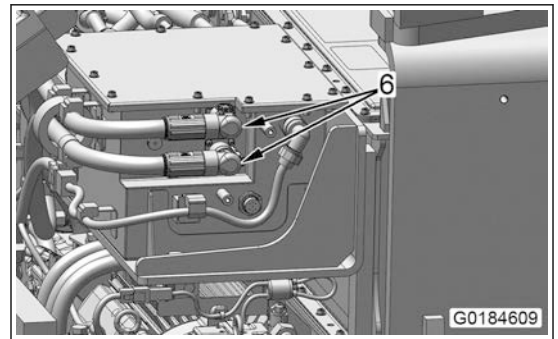
**Measure Battery Voltage**

15. Connect the battery voltage measurement cable B to the BMS side.

REMARK

- Connect the red tape (7) side to the connector at the bottom of the BMS side.
- After the cable is connected, apply force to pull it out, and make sure that it is engaged securely.

16. Fix the battery voltage measurement cable B on a table.

NOTICE

Be sure to do this procedure to measure safely.

17. Insert the voltage tester C to the connector of the battery voltage measurement cable B to measure the voltage.

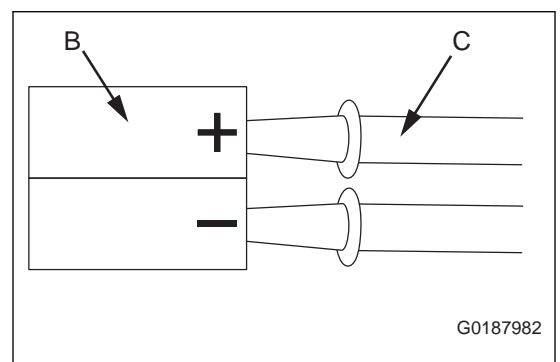
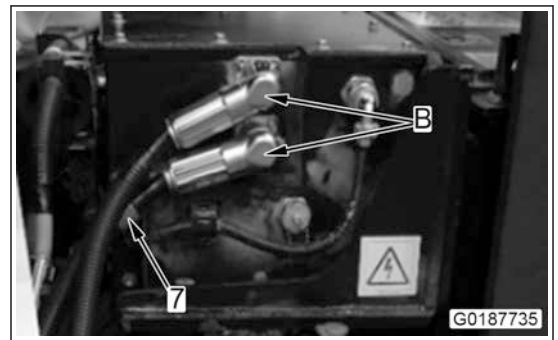

Precautions for Disconnection and Connection of Connectors

Disconnect Connectors

1. Hold the connectors when disconnecting.

When disconnecting the connectors, always hold the connecting portion. If the connector is fixed with screw, loosen the screw of the connector completely, hold the both of male and female connectors, and pull them out in parallel.

NOTICE

Do not pull the connectors with one hand.

REMARK

If it is a lock stopper type connector, pull it out as pushing the stopper (1) with your thumb.

2. When removing a connector from a clip

- Both of the connector and clip have stoppers (2), which are engaged with each other when the connector is connected.
- When removing a connector from a clip, pull the connector in parallel with the clip as removing stoppers.

NOTICE

If the connector is pried up and down or to the right or left, it may break the housing.

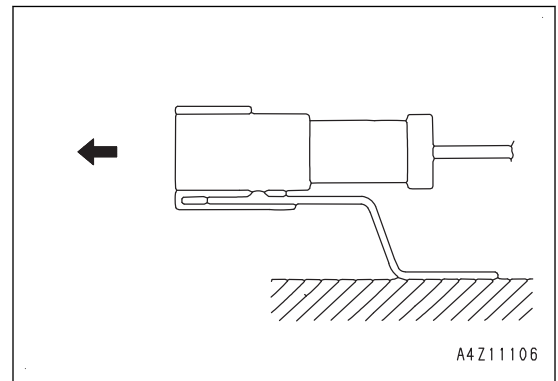
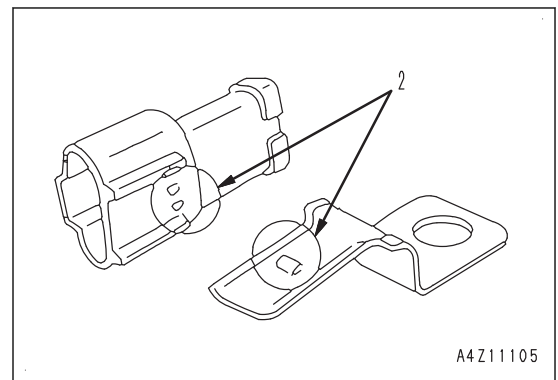
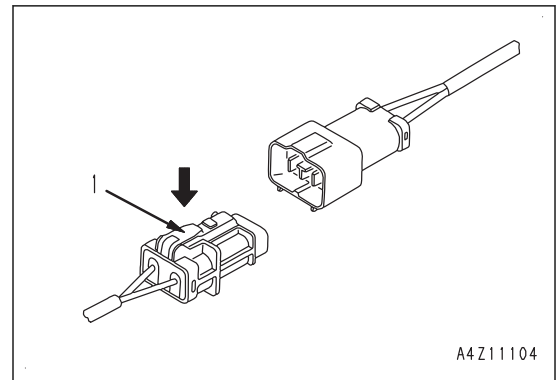

3. Action to be taken after removing connectors

After removing the connector, cover it with plastic bags to prevent entry of dust, dirt, oil, or water in the contact portion.

NOTICE

Be sure to cover the connector with plastic bags when leaving the machine disassembled for a long time, otherwise defective contact may occur.

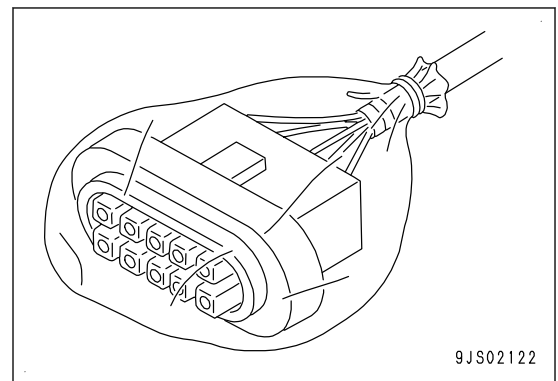

Connect Connectors

1. Check the connector visually.

- Check that there is no dust, dirt, oil, or water stuck to the connector pins (joint portion).

Type of bolt	A		B	
Nominal size - threads per inch	Tightening torque (Nm {kgfm})		Tightening torque (Nm {kgfm})	
	Range	Target	Range	Target
1-8UNC	883 to 1196 {90 to 122}	1040 {106}	245 to 333 {25 to 34}	284 {29}
1 ¹ / ₈ -7UNC	1187 to 1608 {121 to 164}	1393 {142}	333 to 451 {34 to 46}	392 {40}
1 ¹ / ₄ -7UNC	1598 to 2157 {163 to 220}	1873 {191}	451 to 608 {46 to 62}	530 {54}
1 ¹ / ₂ -6UNC	2354 to 3177 {240 to 324}	2765 {282}	657 to 892 {67 to 91}	775 {79}

REMARK

Tighten the unified fine threaded bolts and nuts to the torque shown in the table below unless otherwise specified.

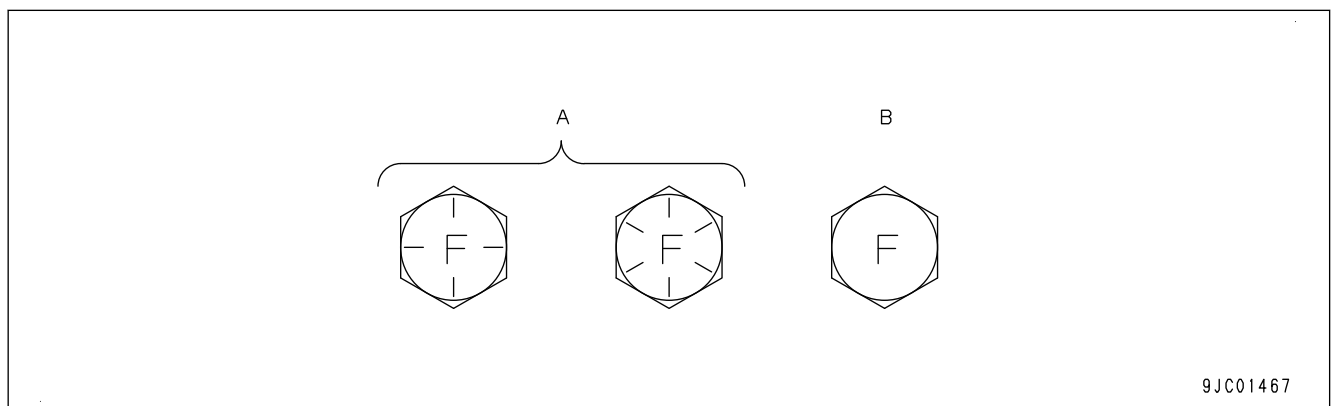

Type of bolt	A		B	
Nominal size - threads per inch	Tightening torque (Nm {kgfm})		Tightening torque (Nm {kgfm})	
	Range	Target	Range	Target
1 ¹ / ₄ -28UNF	14.7 to 19.6 {1.5 to 2}	17.7 {1.8}	3.9 to 4.9 {0.4 to 0.5}	4.41 {0.45}
5 ⁵ / ₁₆ -24UNF	34.3 to 39.2 {3.5 to 4}	34.3 {3.5}	7.8 to 9.8 {0.8 to 1}	8.8 {0.9}
3 ³ / ₈ -24UNF	53.9 to 68.6 {5.5 to 7}	61.8 {6.3}	14.7 to 19.6 {1.5 to 2}	16.7 {1.7}
7 ⁷ / ₁₆ -20UNF	83.4 to 108 {8.5 to 11}	96.1 {9.8}	24.5 to 29.4 {2.5 to 3}	26.5 {2.7}
1 ¹ / ₂ -20UNF	127 to 167 {13 to 17}	147 {15}	34.3 to 49.0 {3.5 to 5}	41.2 {4.2}
9 ⁹ / ₁₆ -18UNF	186 to 245 {19 to 25}	216 {22}	49.0 to 68.6 {5 to 7}	58.8 {6}
5 ⁵ / ₈ -18UNF	255 to 343 {26 to 35}	294 {30}	73.5 to 98.1 {7.5 to 10}	83.4 {8.5}
3 ³ / ₄ -16UNF	441 to 598 {45 to 61}	520 {53}	127 to 167 {13 to 17}	147 {15}
7 ⁷ / ₈ -14UNF	716 to 961 {73 to 98}	843 {86}	196 to 265 {20 to 27}	226 {23}
1-14UNF	1020 to 1373 {104 to 140}	1196 {122}	284 to 382 {29 to 39}	333 {34}
1 ¹ / ₈ -12UNF	1353 to 1844 {138 to 188}	1598 {163}	382 to 520 {39 to 53}	451 {46}
1 ¹ / ₄ -12UNF	1804 to 2432 {184 to 248}	2118 {216}	510 to 686 {52 to 70}	598 {61}
1 ¹ / ₂ -12UNF	2707 to 3658 {276 to 373}	3177 {324}	765 to 1030 {78 to 105}	892 {91}

01 Specifications

System Diagram of Machine Monitor System.....	10-43
Function of Machine Monitor System	10-43
KOMTRAX System	10-45
System Diagram of KOMTRAX System	10-45
Function of KOMTRAX System.....	10-45
Component Parts of Control System	10-46
Machine Monitor	10-46
KOMTRAX Terminal.....	10-56
Machine Controller.....	10-58
Resistor for PC-EPC Valve.....	10-62
Motor Speed Adjustment Dial.....	10-63
Hydraulic System	10-65
Layout Drawing of Hydraulic System.....	10-65
CLSS	10-67
System Diagram of CLSS	10-67
Function of CLSS.....	10-68
Electric Motor and Pump Combined Control System.....	10-70
System Diagram of Electric Motor and Pump Combined Control System.....	10-70
Function of Electric Motor and Pump Combined Control System	10-71
Component Parts of Hydraulic System.....	10-73
Hydraulic Tank	10-73
Main Pump.....	10-78
Control Valve.....	10-90
Work Equipment System.....	10-136
Layout Drawing of Work Equipment System	10-136
Structure of Valve Control	10-139
PPC Lock System	10-141
System Diagram of PPC Lock.....	10-141
Function of PPC Lock System.....	10-143
Work Equipment and Travel Automatic Lock System	10-144
Function of Work Equipment and Travel Automatic Lock System.....	10-144
Operation of Lock Lever Automatic Lock System	10-144
Component Parts of Work Equipment System	10-145
Work Equipment and Swing PPC Valve	10-145
Attachment EPC Valve	10-150
Blade PPC Valve.....	10-151
Boom Swing PPC Valve.....	10-153
Bipartite Solenoid Valve	10-155
Boom Anti-drop Valve	10-159
Arm Anti-Drop Valve.....	10-164
Pilot Circuit Accumulator	10-169
Swing System	10-170
Layout Drawing of Swing System.....	10-170
Component Parts of Swing System.....	10-171
Swing Motor.....	10-171
Swing Machinery.....	10-178
Swing Circle.....	10-180
Travel System	10-181
Layout Drawing of Travel System.....	10-181
System Diagram of Travel Control System.....	10-183
Function of Travel Control System	10-183
Component Parts of Travel System.....	10-185
Travel Motor.....	10-185
Travel PPC Valve	10-194
Center Swivel Joint	10-197
Undercarriage and Frame	10-198
Layout Drawing of Undercarriage.....	10-198
Specifications of Undercarriage	10-199

High Voltage Wiring (Power Cable)

Layout Drawing of High Voltage Wiring (Power Cable)

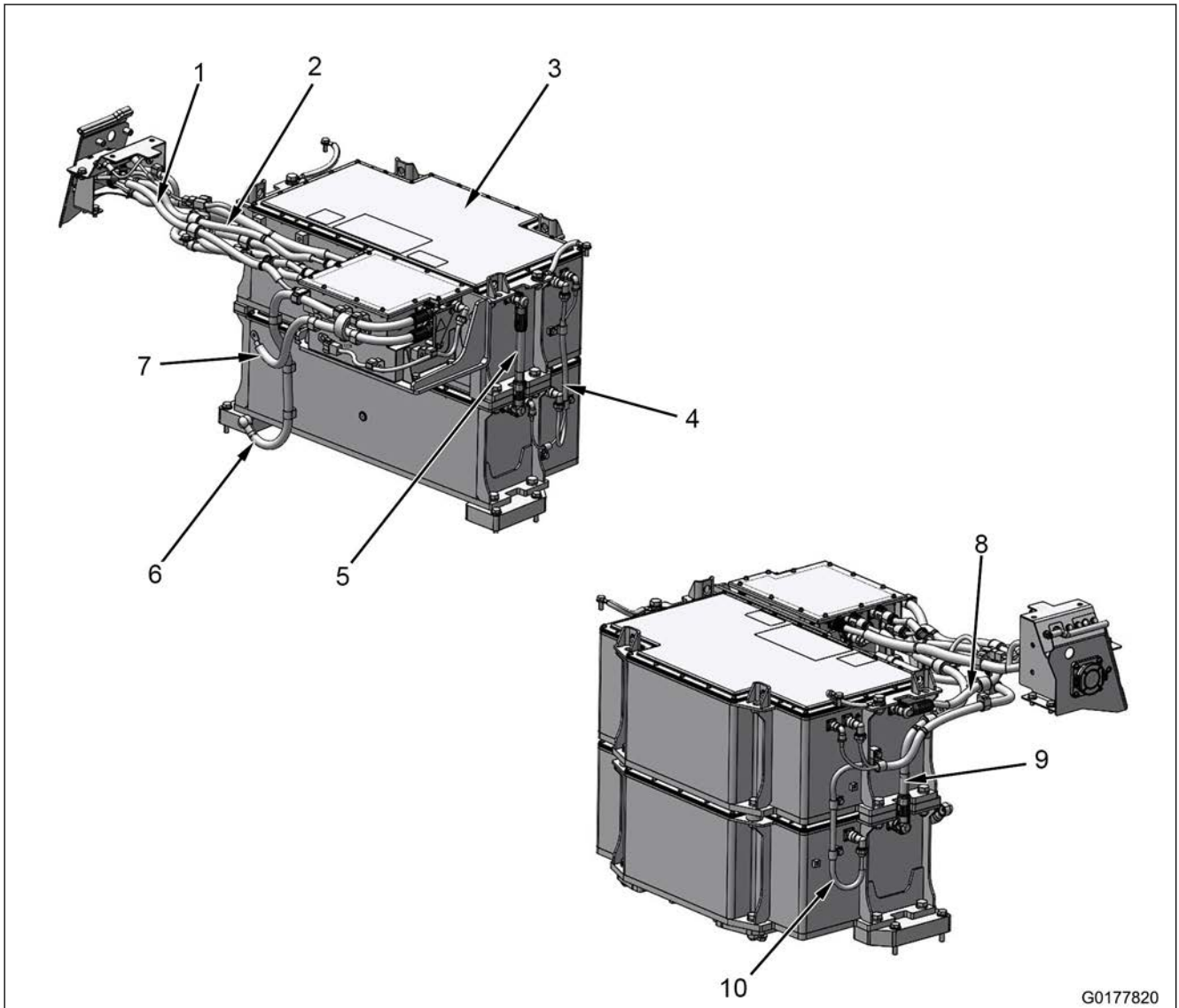

1: High voltage wiring (charge cable +)

2: High voltage wiring (charge cable -)

3: Battery

4: High voltage wiring (BMS, heater cable)

5: High voltage wiring (Upper and lower relay cable)
(*1)

6: High voltage wiring (output cable -)

7: High voltage wiring (output cable +)

8: High voltage wiring (DC cable +) (*1)

9: High voltage wiring (DC cable -) (*1)

10: High voltage wiring (BMS, heater cable)

*1: The wiring is activated continuously even if the power supply is set to OFF. When you do the maintenance and repair work, put a insulation cover over it, and handle it carefully.

Structure of High Voltage Wiring (Power Cable)

The wire uses a waterproof and shield structure.

Function of High Voltage Wiring (Power Cable)

The high voltage wiring supplies the high voltage power.

Electric Motor

Structure of Electric Motor

General View

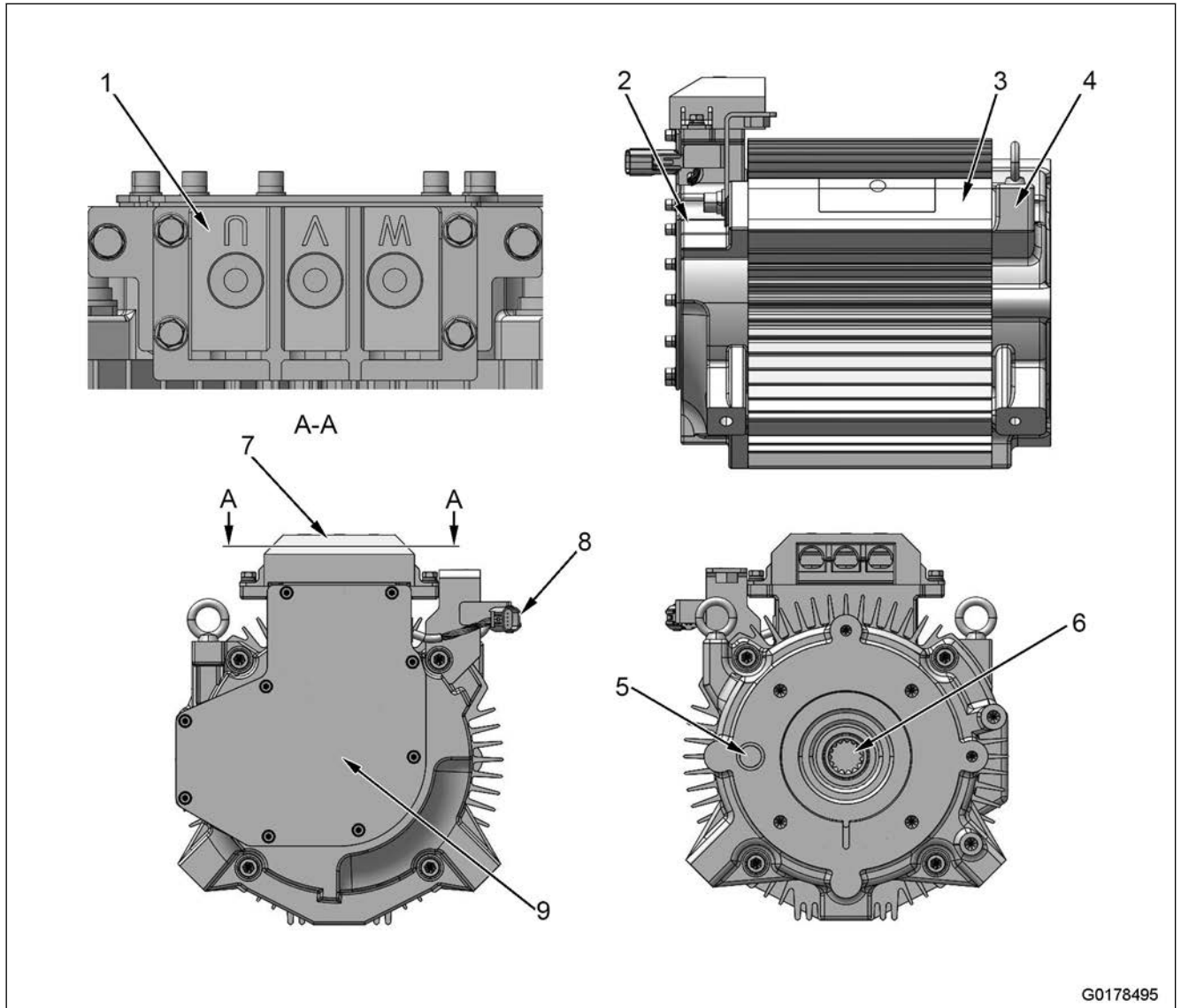

1: Terminal block

2: Bracket (anti-connection side)

3: Frame

4: Bracket (connection side)

5: Air breather

6: Involute spline hole

7: Terminal cover

8: Sensor connector

9: Sensor cover

Function of Electric Motor

The electric motor converts the electric energy to mechanical energy (rotation), and transmits the energy to the main pump.

KOMTRAX System

System Diagram of KOMTRAX System

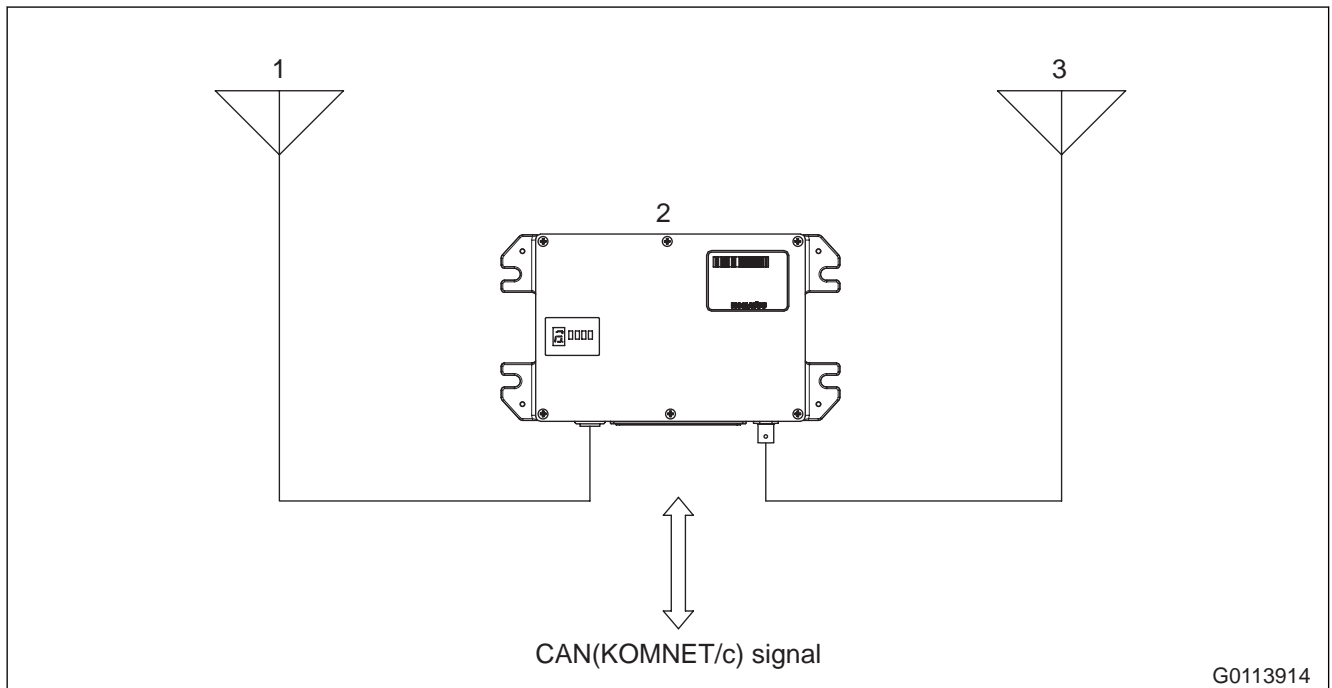

1: KOMTRAX GPS antenna

3: KOMTRAX communication antenna

2: KOMTRAX terminal

The KOMTRAX system consists of the KOMTRAX terminal, communication antenna, and GPS antenna.

Function of KOMTRAX System

- The KOMTRAX system transmits the information on the machine through radio communication. KOMTRAX administrator refers this information at the office, and supplies the services to customers.
- The KOMTRAX system transmits the information that follows.
 - Position information
 - Operation information
 - Alarm and failure information
 - Power consumption information
 - Maintenance information
 - Machine work condition information

REMARK

The radio station for KOMTRAX must be established separately to start the services.

Pin No.	Signal name	Input/output signal
15	(*1)	-
16	Stationary charger connection detection signal 1	Input
17	(*1)	-
18	GND (analog signal)	-
19	(*1)	-
20	Model selection switch 2	Input
21	(*1)	-
22	PPC lock solenoid relay operation monitor signal	Input
23	Working lamp switch	Input
24	CPU24 signal	Input
25	(*1)	-
26	CAN1_L(J1939)	Input/output
27	(*1)	-
28	Hydraulic oil temperature sensor	Input
29	Travel PPC pressure sensor	Input
30	Swing parking brake cancel PPC pressure sensor	Input
31	L.H. ATT control lever (main)	Input
32	(*1)	-
33	(*1)	-
34	(*1)	-
35	(*1)	-
36	(*1)	-
37	GND (digital signal)	-
38	(*1)	-
39	Model selection switch 1	Input
40	Work equipment PPC pressure switch	Input
41	PPC lock lever cancel signal	Input
42	Travel speed increase switch	Input
43	CPU24 signal	Input
44	(*1)	-
45	CAN0_H (KOMNET/c)	Input/output
46	GND (analog signal)	-
47	GND (analog signal)	-
48	(*1)	-
49	Service pressure sensor 2	Input
50	(*1)	-
51	R.H. ATT control lever (sub)	Input
52	(*1)	-
53	(*1)	-

Component Parts of Hydraulic System

Hydraulic Tank

Structure of Hydraulic Tank

General View

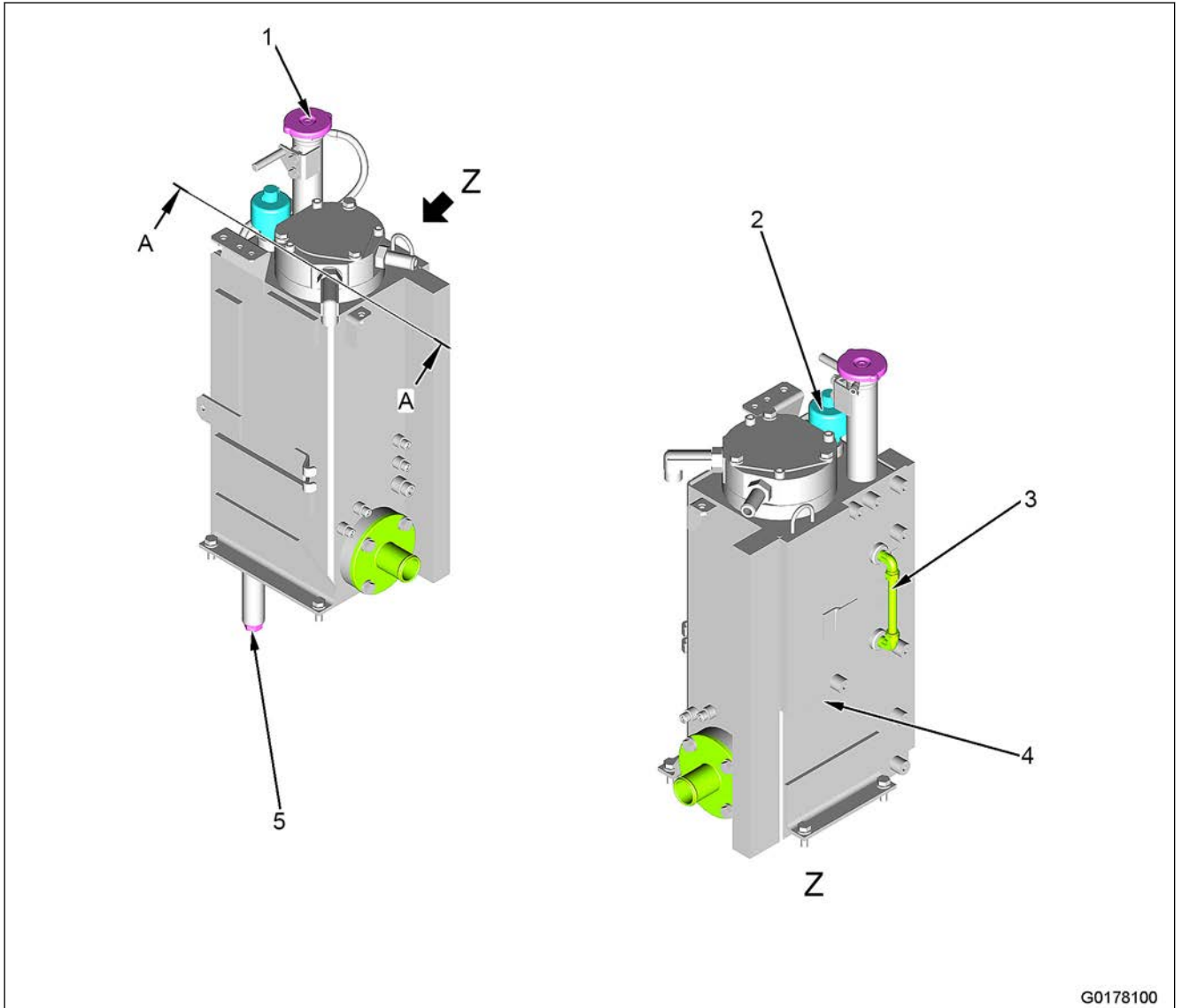

G0178100

- 1: Oil filler cap
- 2: Breather
- 3: Sight gauge

- 4: Hydraulic tank
- 5: Drain plug

4. As the servo piston (6) moves, the lever (1) moves to the right, and the spring (2) compresses to increase the spring force. The spool (3) moves to the right, and the port (C) and pump discharged pressure (B) are disconnected. The drain port (D) and port (C) are connected.
5. The pressure in the port (C) decreases, the piston pressure decreases, and the servo piston (6) stops and does not move to the right.

Operation When Servo Piston Stops (Balanced)

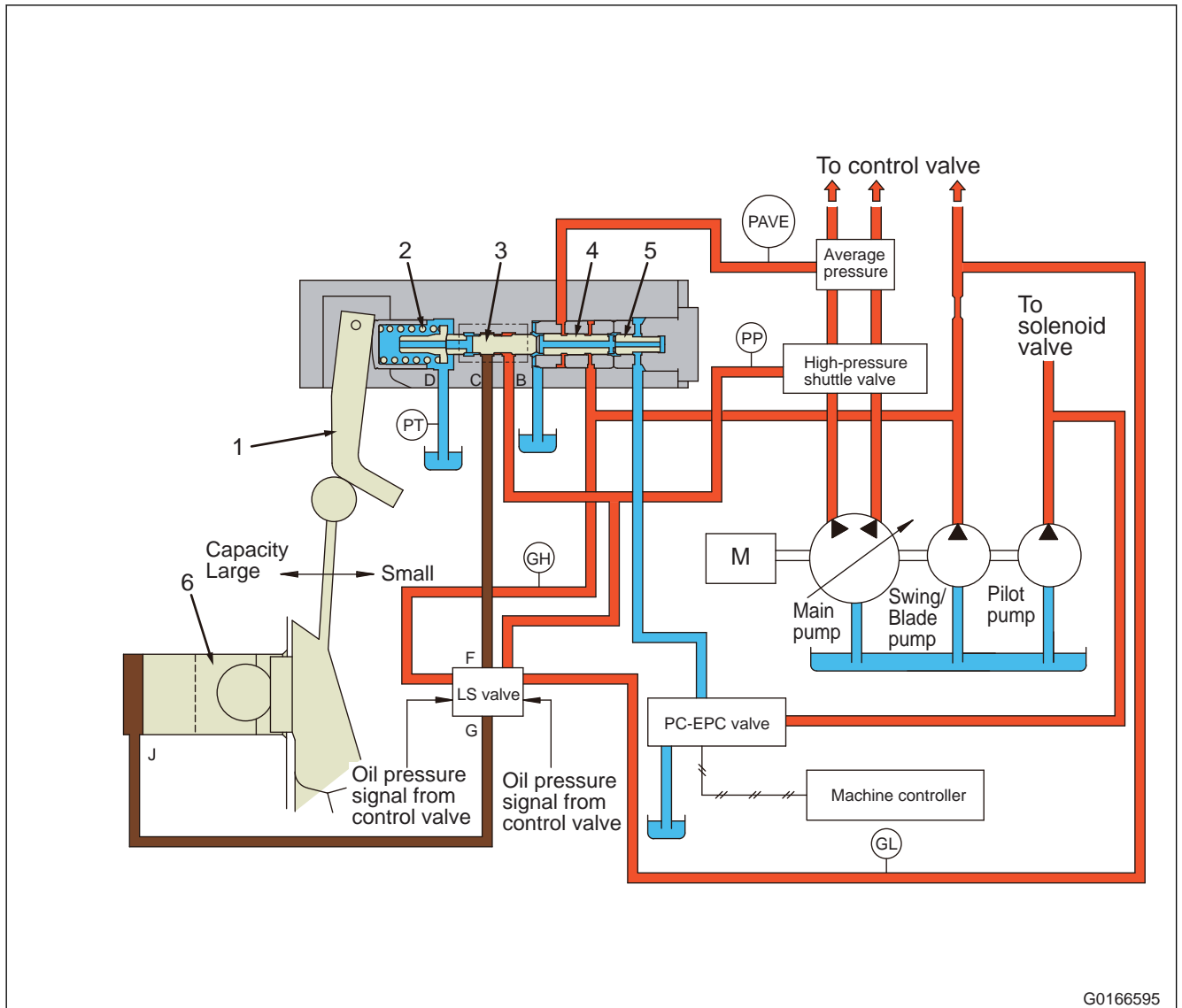

The servo piston (6) stops at the position (= pump discharged volume) where the push force caused by the pump average pressure (PAVE) applied to the spool (4) is balanced with the force of the spring (2).

When Swing and Blade Pump Pressure Increases or Decreases

The pressure applied to the spool (4) changes, and the stop position of the servo piston (6) is set as when the pump average pressure (PAVE) increases or decreases.

When PC-EPC Valve is in Operation

The signal current from the controller changes the output pressure of the PC-EPC valve, and the pressure applied to the spool (5) changes. The stop position of the servo piston (6) is set as when the pump average pressure (PAVE) increases or decreases.

Sectional View (AD-AD, AP-AP, AQ-AQ)

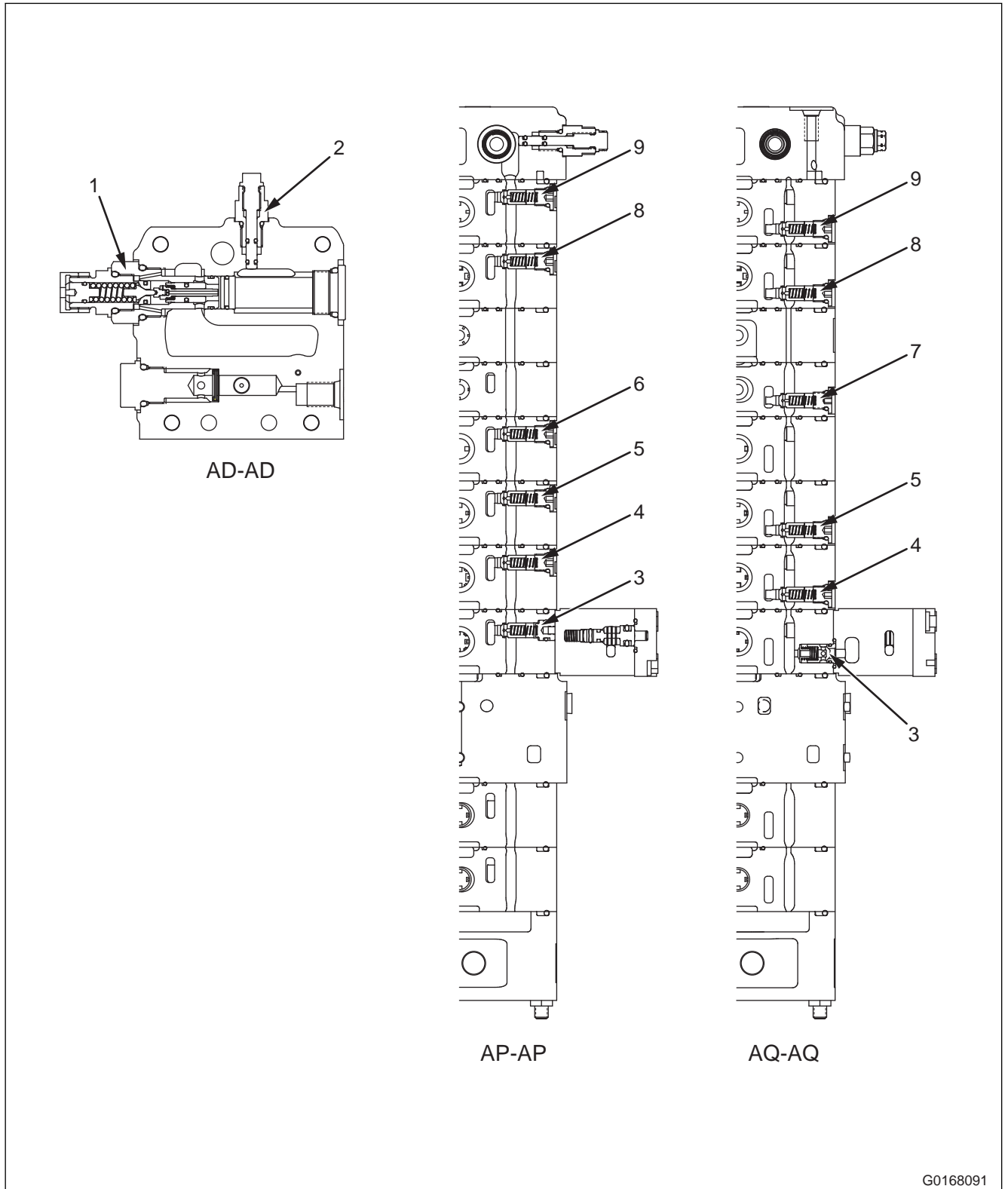

G0168091

- 1: Safety valve
- 2: Pressure relief plug
- 3: Check valve (boom)
- 4: Check valve (arm)
- 5: Check valve (bucket)

pressure (PLS) and actuator circuit pressure (PA) (pressure in port (A)), the flow rate from the pump is divided more to the compensated side as the opening area of the compensating pressure compensation valve becomes small.

Operation of Travel Junction Valve of Control Valve During Straight Travel

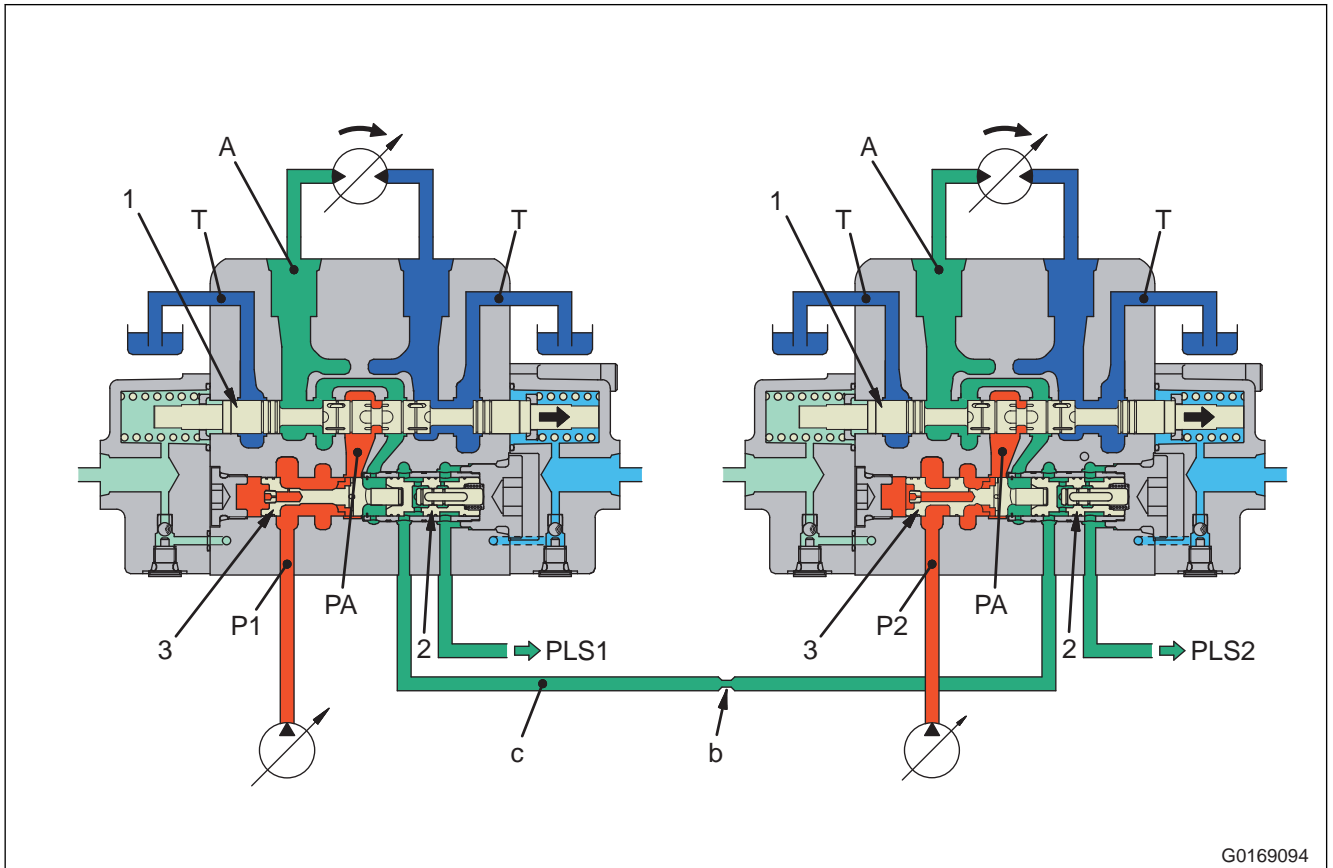

G0169094

1. When the right and left travel spools (1) are operated, the pump discharged volume flows from the pump circuits (P1) and (P2) and circuit (PA) to the actuator circuit (A).
2. At this time, the pressure reducing valve (2) for the right and left travel is pushed to the right, and the notch (a) opens.
3. Accordingly, the right and left travel actuator circuits (A) are connected by the junction circuit (c). If there is a difference in the flow rate between the right and left travel motors, it is compensated to reduce the travel deviation.

13: Breaker operation switch	18: Control valve
14: 1st-line attachment proportional switch	18a: Merge-divider valve
15: 1st-line attachment flow adjustment EPC valve	19: Main pump
16: PPC lock solenoid valve	20: Electric motor
17: Swing motor	21: Inverter
17a: Swing parking brake	

Function of PPC Lock System

- The PPC lock switch is connected to the lock lever. When the lock lever is set to the LOCK position, the PPC lock switch is turned OFF.
- When the PPC lock switch is set to OFF, the current to the PPC lock solenoid valve is cut out. As a result, the work equipment and machine will not move even when the control levers and pedals are operated.

Check Valve (When Electric Motor is Stopped)

The check valve is installed between the port (P) and PPC solenoid valve. When the electric motor is stopped, the reaction force of the spring (2) pushes the plunger (1) back to the left. It closes the circuit between the port (ACC) and port (P), and the accumulated pressure is kept in the accumulator.

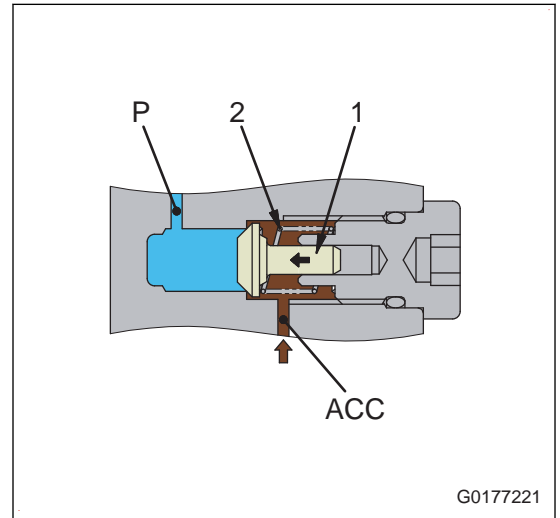

Check Valve (When Electric Motor is in Operation)

While the electric motor is in operation, the pilot oil pressure that flows to the port (P) pushes the plunger (1) to the right, and the port (P) and port (ACC) are connected.

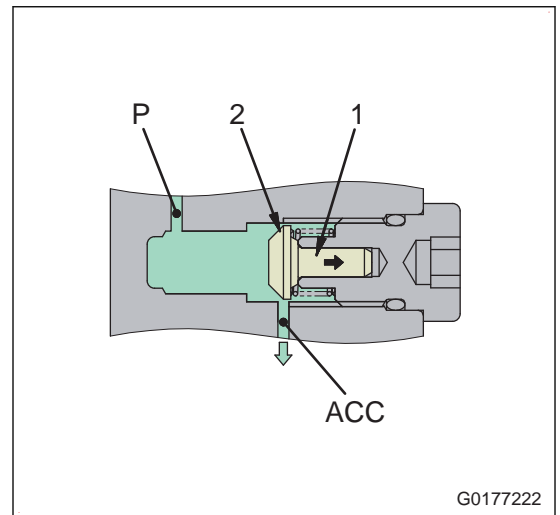

Component Parts of Swing System

Swing Motor

Structure of Swing Motor

General View

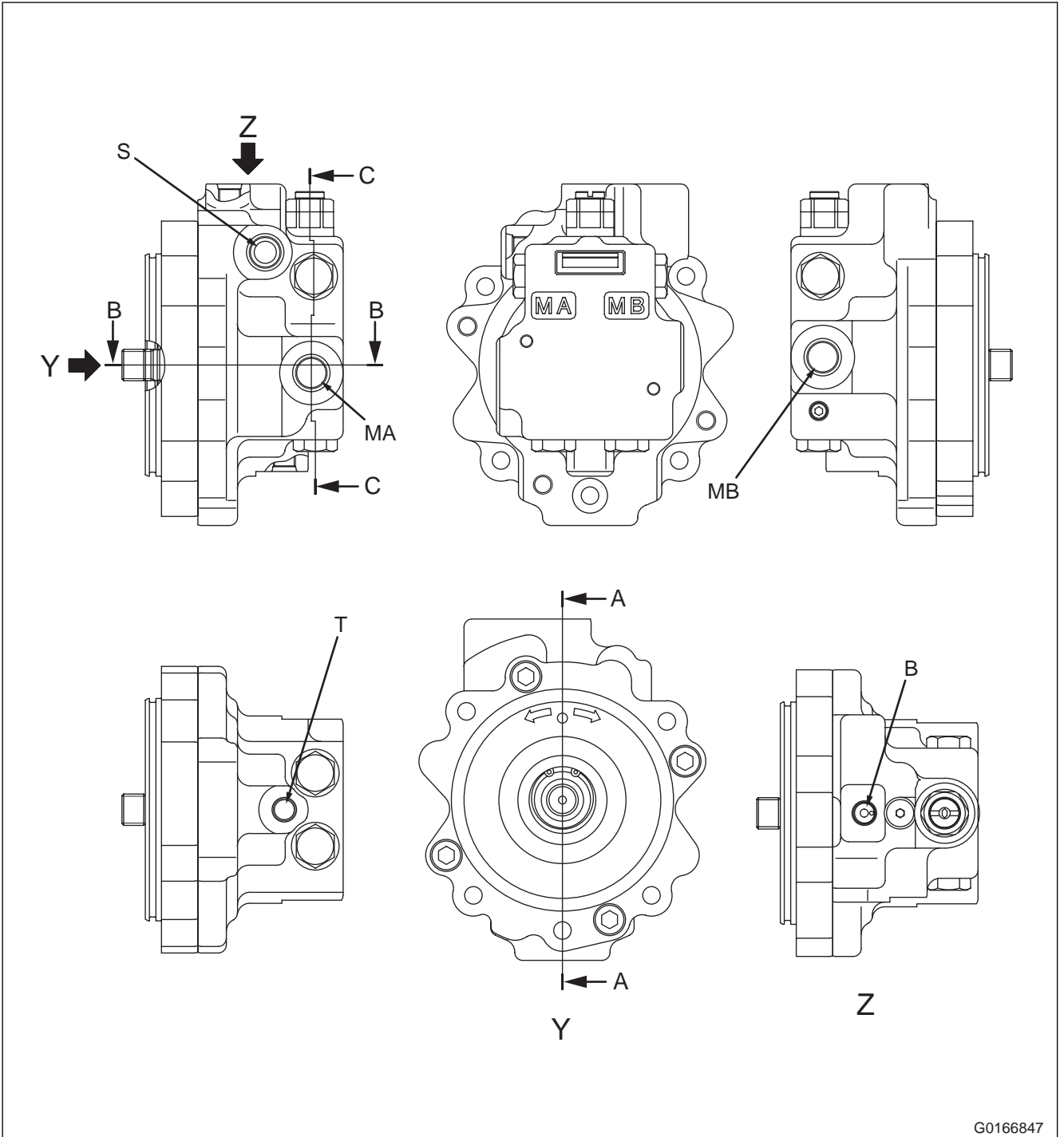

G0166847

B: From control valve

S: From control valve

MA: From control valve (swing LEFT port)

MB: From control valve (swing RIGHT port)

T: To hydraulic tank

Component Parts of Travel System

Travel Motor

Structure of Travel Motor

General View

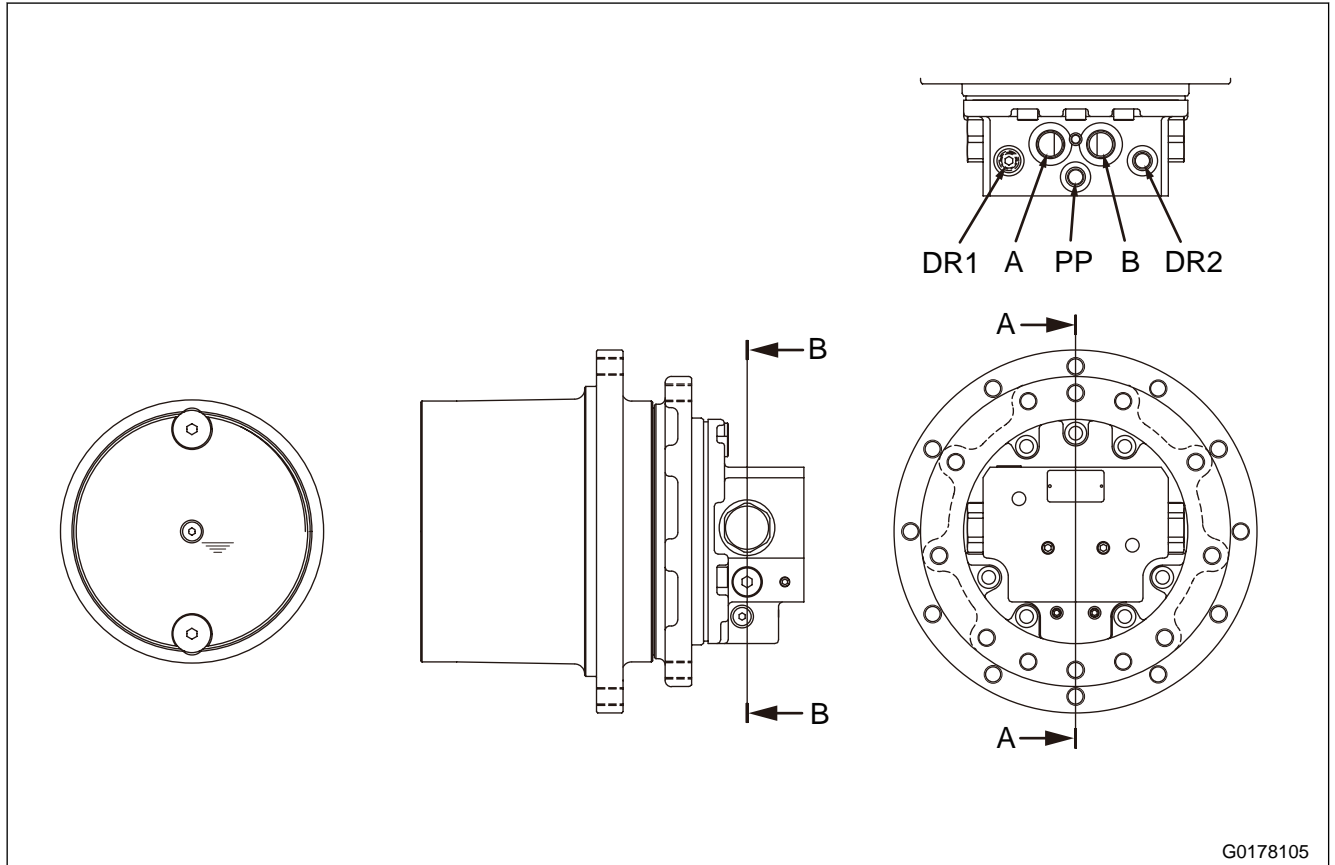

G0178105

L.H. travel motor

A: From control valve (left travel FORWARD port)

B: From control valve (left travel REVERSE port)

DR1: To hydraulic tank

DR2: Plug

PP: From 2nd travel speed solenoid valve

R.H. travel motor

A: From control valve (right travel REVERSE port)

B: From control valve (right travel FORWARD port)

DR1: Plug

DR2: To hydraulic tank

PP: From 2nd travel speed solenoid valve

Specifications of Undercarriage

Quantity of Carrier Rollers (One Side)

1 piece

Quantity of Track Rollers (One Side)

4 pieces

Travel

Item	Test condition	Unit	Standard value for new machine	Failure judgment criteria
Travel speed	<ul style="list-style-type: none"> Hydraulic oil temperature: 45 to 55°C Motor speed adjustment dial: High idle position Working mode: P (Power Mode) Time required for 20 m travel after a 10 m run on a level ground Measuring posture: See “Fig. 4” in “Machine Posture and Procedures to Measure Performance”. 	Low speed	25.7 to 29.7	23.7 to 31.7
		High speed	13.7 to 17.7	11.7 to 19.7
Travel deviation	<ul style="list-style-type: none"> Hydraulic oil temperature: 45 to 55°C Motor speed adjustment dial: High idle position Working mode: P (Power Mode) Travel deviation (X) in travel of 20 m after a 10 m run on a firm and level ground Measurement posture: See “Fig. 4” and “Fig. 5” in “Machine Posture and Procedures to Measure Performance”. 	Low speed	Max. 300	Max. 330
		High speed	Max. 300	Max. 330
Hydraulic drift while the machine travels	<ul style="list-style-type: none"> Hydraulic oil temperature: 45 to 55°C Electric motor is stopped Turn the sprocket side up on the slope of 30°, and stop the machine. Travel distance by machine drift for 5 minutes Measuring posture: See “Fig. 6” in “Machine Posture and Procedures to Measure Performance”. 	mm	0	0

Related Information on Testing and Adjusting

Tools for Examination and Adjustment

Tools to Examine Swing Circle Bearing Clearance

Symbol	Part No.	Part name	Number	Remark
A	Commercially available	Dial gauge	1	

Tools to Examine and Adjust Track Tension

Symbol	Part No.	Part name	Number	Remark
A	Commercially available	Wooden block	1	

Tools to Examine and Adjust Oil Pressure in Work Equipment, Travel, and Boom Swing Circuits

Symbol	Part No.	Part name	Number	Remark	
A	-	799-101-5002	Hydraulic tester	1	
	1	799-101-5120	Gauge	1	Pressure range: 40MPa
	2	799-101-5130	Gauge	1	Pressure range: 6MPa
B	790-261-1205	Digital hydraulic tester	1	Pressure range: 70MPa	
C	799-101-5220	Nipple	1	Size: M10 x 1.25 mm	
D	07002-11023	O-ring	1		
E	Commercially available	Pin	1	<ul style="list-style-type: none"> • Material quality: SS400 • Diameter: 50mm • Length: 100mm 	
F	799T-404-8500	Sensor adapter	1	Pressure range: 50MPa	

Tools to Examine and Adjust Swing and Blade Circuit Oil Pressure

Symbol	Part No.	Part name	Number	Remark	
A	-	799-101-5002	Hydraulic tester	1	
	1	799-101-5120	Gauge	1	Pressure range: 40 MPa
B	790-261-1205	Digital hydraulic tester	1	Pressure range: 70 MPa	
C	799-101-5220	Nipple	1	Size: M10 x 1.25 mm	
D	07002-11023	O-ring	1		
E	799T-404-8500	Sensor adapter	1	Pressure range: 50 MPa	

6. Operate the work equipment control lever to the full stroke in the boom LOWER direction.
7. Make sure that the work equipment is lowered to the ground.

NOTICE

If the work equipment does not lower or stops halfway, the pressure in the PPC accumulator can drop. You cannot release the remained pressure in this procedure.

REMARK

- The state of the PPC accumulator is correct when the work equipment is lowered to the ground by its own weight.
- The PPC accumulator is a periodic inspection item and an important periodic replacement part.

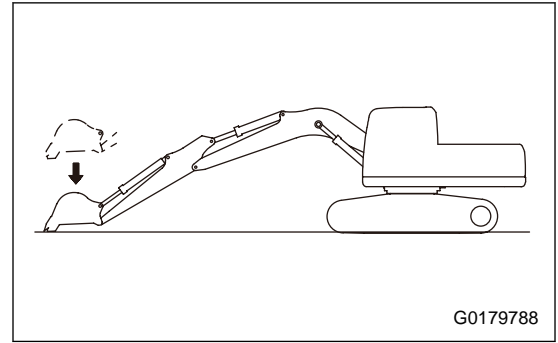
**Procedure to release remained pressure**

8. Start the electric motor.
9. Set the machine to the posture shown below, and lower the work equipment to the ground.

Arm cylinder: Fully extended (maximum arm IN)

Bucket cylinder: Fully extended (maximum bucket CURL) or fully retracted (maximum bucket DUMP)

REMARK

The boom anti-drop valve is installed at the boom cylinder bottom side. When the work equipment is lowered to the ground in this posture, the bottom side of the boom cylinder is stopped in the drain state, and the remained pressure becomes low.

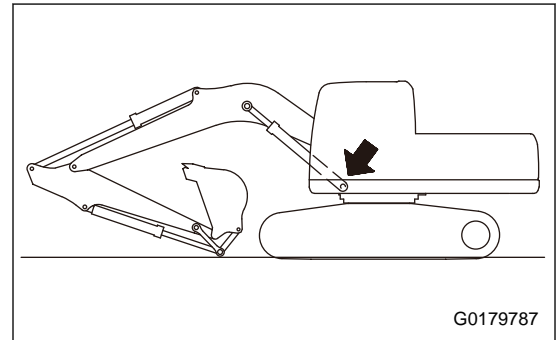

10. Turn the starting switch to the OFF position.
11. Release the remained pressure from the hydraulic tank. For details, see "How to Release Remained Pressure from Hydraulic Tank".

REMARK

Keep the oil filler cap of the hydraulic tank removed.

12. Turn the starting switch to the ON position.
13. Set the lock lever to the FREE position, and operate the R.H. and L.H. work equipment control levers to back and forth, left to right.

REMARK

The work equipment can be operated by the pressure charged in the PPC accumulator. But the pressure in the PPC accumulator is released after the work equipment control levers are operated several times.

14. Set the lock lever to the LOCK position.
15. Start the electric motor.
16. Set the motor speed adjustment dial to the MIN (low idle) position. Run the engine for approximately 10 seconds to charge pressure in the PPC accumulator.
17. Do the Steps 12, 13, 14, 15, and 16 continuously 4 to 5 times, and fully release the remained pressure in the hydraulic cylinder circuit.

▲ Before you remove the anti-drop valve, gradually loosen the mounting bolt of the anti-drop valve, and make sure that the oil pressure is released fully.

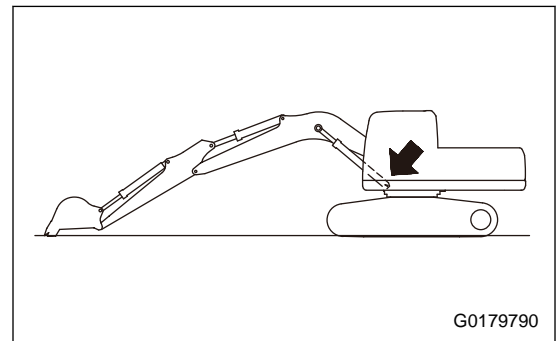

Restoration

9. Stop the electric motor.
10. Remove the pin E from the sprocket and track frame.
11. Remove the gauge A1.
12. Remove the nipple C.
13. Install the plug.
14. Install the cover on the left rear side of the machine.

How to Examine Boom Swing Relief Pressure by Machine Monitor

Prepare for test

1. Release the remained pressure from the hydraulic tank. For details, see “Release Remained Pressure from Hydraulic Circuit”.
2. Remove the cover on the left rear side of the machine.
3. Remove the plug of the main pump discharged pressure pickup port (P1) or (P2).

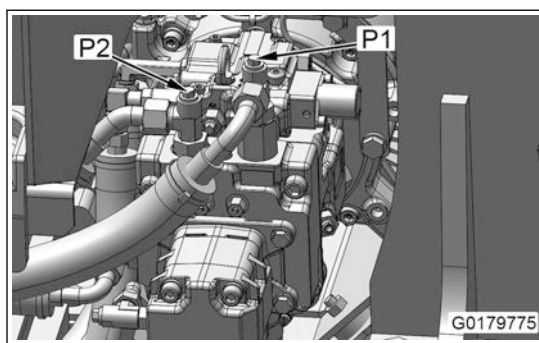

4. Install the nipple C, and connect the coupling (P11) or (P12) of the sensor adapter F.

REMARK

- The coupling (P11) side is shown with monitoring code: 01141 “Service Press. Sens1”.
- The coupling (P12) side is shown with monitoring code: 01142 “Service Press. Sens2”.

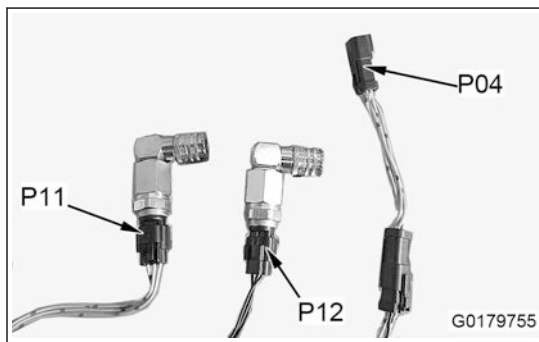
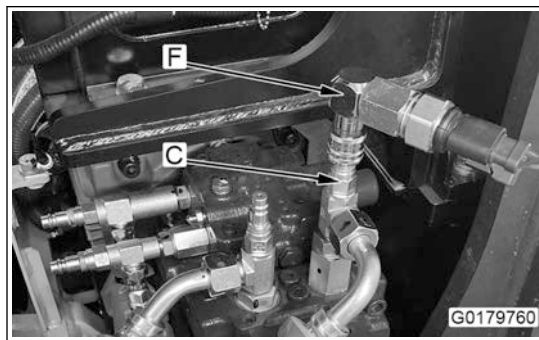

Check procedure

12. Examine oil pressure when the motor speed control dial is set in the MAX (high idle) position.

Restoration

13. Stop the electric motor.
14. Remove the sensor adapter E.
15. Remove the nipple C.
16. Install the plug.
17. Install the covers on the front left side and the rear left side of the machine.

How to Examine Oil Pressure of Control Circuit by Testing Tools**Set testing tool**

1. Release the remained pressure from the hydraulic tank. For details, see "Release Remained Pressure from Hydraulic Circuit".
2. Remove the cover on the left rear side of the machine.
3. Remove the plug of the pilot pump discharged pressure pickup port (P4).

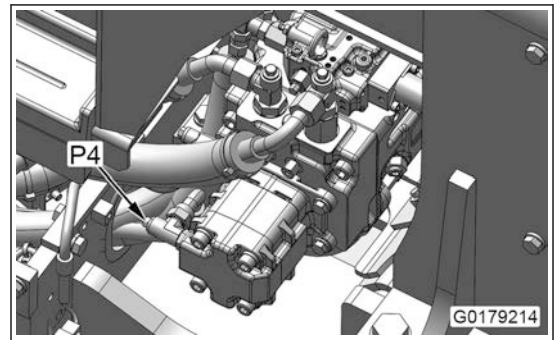

4. Install the nipple C, and connect the gauge A1 in the hydraulic tester A.

REMARK

The gauge in the digital hydraulic tester B can be used instead of the gauge A1.

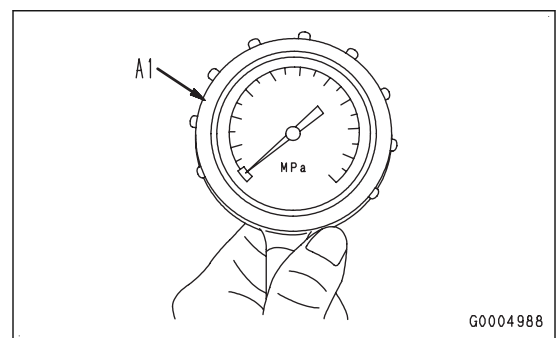
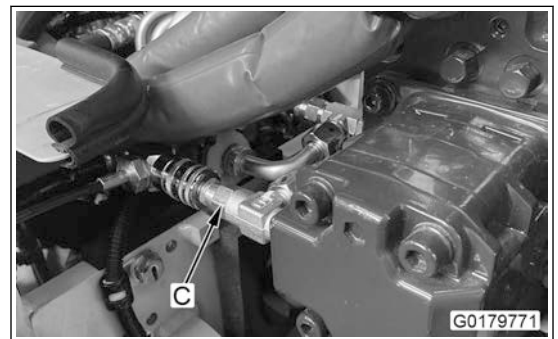
**Set measurement condition**

5. Start the electric motor and keep the hydraulic oil temperature in the specified inspection condition range.
Hydraulic oil temperature: 45 to 55°C
6. Set the working mode to P ("Power Mode").
7. Disable the auto-decelerator.

PPC Valve Piping Connection Table

Target circuit and operation	Port name at control valve side	Band color
Right travel (Forward)	PA1	Black/Yellow
Right travel (Reverse)	PB1	Green/Yellow
Left travel (Forward)	PA2	Brown/Yellow
Left travel (Reverse)	PB2	Orange/Yellow
Boom LOWER	PA3	Black
Boom RAISE	PB3	Yellow
Arm OUT	PA4	Orange
Arm IN	PB4	Green
Bucket DUMP	PA5	Red
Bucket CURL	PB5	Blue
Boom swing RIGHT	PA6	White/Blue
Boom swing LEFT	PB6	White/Red
Blade RAISE	PA7	Red/Yellow
Blade LOWER	PB7	Blue/Yellow
Swing RIGHT	PA8	Brown
Swing LEFT	PB8	White

For the standard values, see Standard Value Table, “Standard Value Table for Machine”.

How to Examine Outlet Pressure of PPC Valve with Machine Monitor

The outlet pressure in the travel PPC valve can be monitored with the machine monitor.

See “Set and Operate Machine Monitor”, and show and examine (06/13) “Predefined Mon” or monitoring code: 07101 “Travel PPC Pressure”.

REMARK

PPC valve outlet pressures other than the travel PPC valve outlet pressure can be monitored with the sensor adapter D. For the test procedure to use the sensor adapter D, see the procedure that follows.

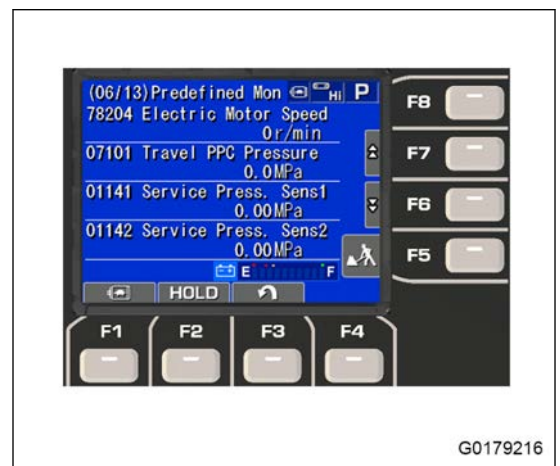

Prepare for test

1. Release the remained pressure from the hydraulic tank. For details, see “Release Remained Pressure from Hydraulic Circuit”.
2. Release the remained pressure in the cylinder circuit. For details, see “Release Remained Pressure from Hydraulic Circuit”.
3. Remove the cover on the left front side of the machine.
4. Remove the cover on the left rear side of the machine.
5. Open the floor. For details, see “How to Open and Close Floor”.
6. Disconnect the hose of the PPC circuit to be examined at the PPC valve side or control valve side.
7. Connect the adapter C, and connect the disconnected hose again.

⚠ Do not operate the lever to the bucket DUMP side.

- Wait for 30 seconds after the relief is started, and measure the leakage quantity from the cylinder head side for 1 minute with the measuring cylinder A.

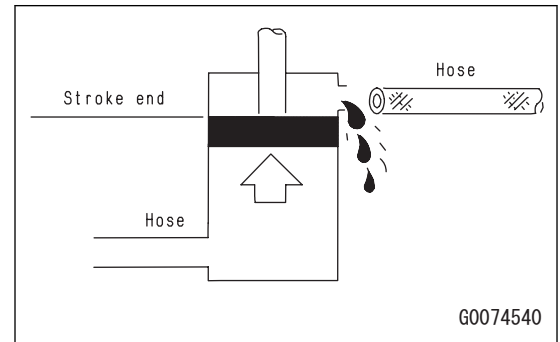

Restoration

- Stop the electric motor.
- Release the remained pressure in the bucket cylinder circuit. For details, see "Release Remained Pressure from Hydraulic Circuit".
- Remove the plug B, and install the hose (1).

 Hose (1): 54 to 93Nm {5.5 to 9.5kgfm}

How to Examine Oil Leakage from Boom Swing Cylinder

Set testing tool

- Start the electric motor.
- Set the boom swing cylinder to the most extended state (maximum swing LEFT).
- Stop the electric motor.
- Release the remained pressure in the boom swing cylinder circuit. For details, see "Release Remained Pressure from Hydraulic Circuit".
- Disconnect the hose (1) at the cylinder head side, and install the plug C at the hose side.

⚠ Do not disconnect the hose at the cylinder bottom side.

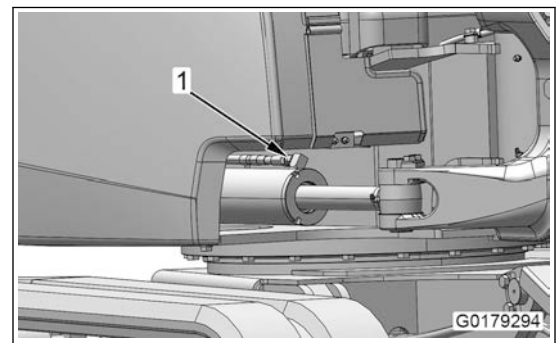

Set measurement condition

- Start the electric motor.
- Make sure that the hydraulic oil temperature is in the measurement condition range.
Hydraulic oil temperature: 45 to 55°C
- Turn the motor speed adjustment dial to the MAX (high idle) position.

Check procedure

- Do the boom swing relief to the left.

⚠ Do not operate the lever to the right.

15. Insert the lock pin (12) securely into the lock hole (b) from the inside.
16. Rotate the lock pin (12) until the detachment prevention hook on the top of the lock pin is securely caught by the pin (13) in the insertion part.

NOTICE

Make sure that the lock pin is securely caught in the pin and is not removed.

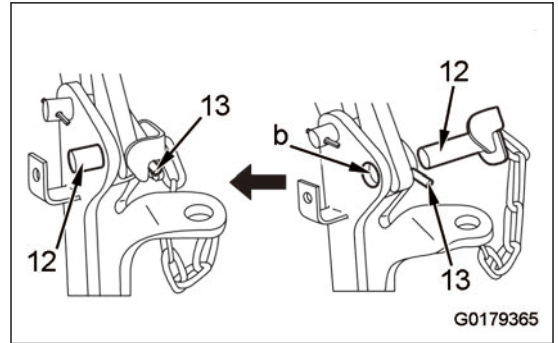

17. Put a cover on the wiring, which is always active, with the insulation sheet (14).

REMARK

- For cables that are always active, see Structure and Function, “High Voltage Wiring (Power Cable)”.
- Put on the correct protective equipment for the equipment for which check or maintenance is required.
- For protective equipment, see Index and Foreword, “Precautions for Inspection and Maintenance of High Voltage Parts”.



Procedure to Close Floor

1. Remove the insulation sheet (14) of the wiring, which is always active.



2. Remove the lock pin (12) of the second lock, and insert it into the storage hole (c).
If the lock pin (12) does not come off, hold the handle and raise the lock pin (12) to remove it.

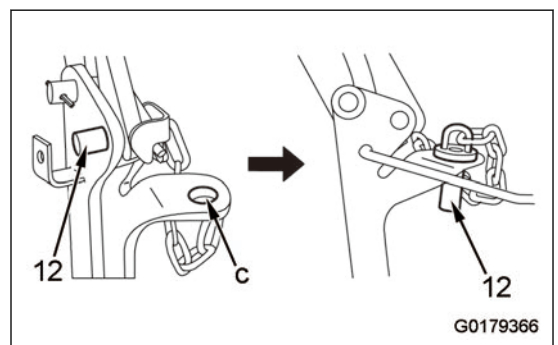

Predefined Mon (11/13) Motor Operation Directive

No.	Monitoring code	Table of monitoring items (shown on screen)	Unit			Applicable component
			SI	Metric	Imperial	
1	78204	Electric Motor Speed	r/min	rpm	rpm	MCN
2	78205	Elec Motor Torque	Nm	kgfm	lbft	MCN
3	65000	Motor Speed Command	r/min	rpm	rpm	MCN
4	65001	Motor Torque Command	Nm	kgfm	lbft	MCN

Predefined Mon (12/13) Electric Fan (1)

No.	Monitoring code	Table of monitoring items (shown on screen)	Unit			Applicable component
			SI	Metric	Imperial	
1	64591	Elec Fan Drive Relay	ONOFF	ONOFF	ONOFF	MCN
2	64592	ElecFan LowSpd Relay	ONOFF	ONOFF	ONOFF	MCN
3	78200	Electric Motor Temp	°C	°C	F°	MCN
4	64593	Invertor Temp	°C	°C	F°	MCN

Predefined Mon (13/13) Electric Fan (2)

No.	Monitoring code	Table of monitoring items (shown on screen)	Unit			Applicable component
			SI	Metric	Imperial	
1	64591	Elec Fan Drive Relay	ONOFF	ONOFF	ONOFF	MCN
2	64592	ElecFan LowSpd Relay	ONOFF	ONOFF	ONOFF	MCN
3	78200	Electric Motor Temp	°C	°C	F°	MCN
2	04401	Hydraulic Oil Temp	°C	°C	F°	MCN

How to See Battery Information

The battery condition can be examined in real-time by battery information on the number of charges, charge time, and communication information with the controller that controls the battery.

1. Select "Battery Information" on "Service Menu" screen.

REMARK

For the procedure to select this item, see "How to Operate Service Mode".



- This is the screen shown when all the abnormality records are deleted.

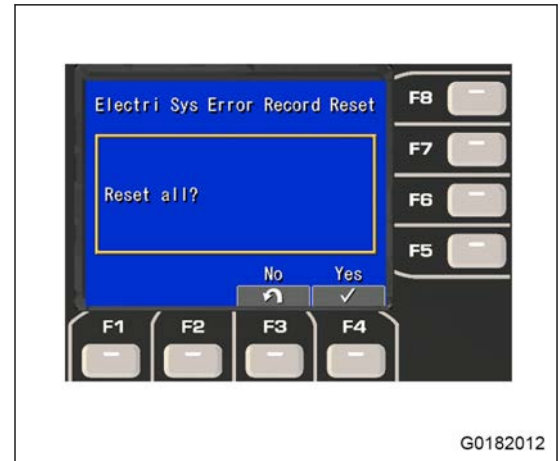

4. After the abnormality records were deleted, the screen to tell the end of the deletion is shown. Then, the screen goes back to "Electric Sys Error Record" (deletion mode) screen.

REMARK

- This is the screen when individual abnormality records are deleted.



- This is the screen shown when all the abnormality records are deleted.



How to See Maintenance Record

The machine monitor saves the maintenance information of the filters and oils. You can show and examine the maintenance record in accordance with the procedures that follow.

If the reset operation is done in the operator mode during maintenance, the number of maintenance done is saved on the abnormality.

2. When "Adjustment" screen is shown, select "Pump Absorption Torque" with the function switches.
 F3: The screen goes back to the "Service Menu" screen.
 F4: Enters the selected item.
 F8: Goes to the code input screen.

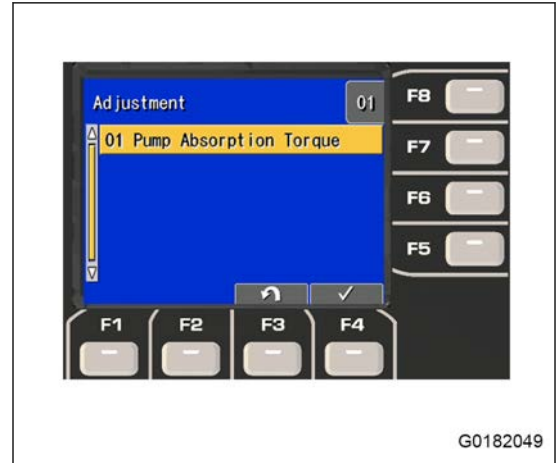

G0182049

3. When "Pump Absorption Torque" screen is shown, change the set value with the function switches.
 Set value: See the table for actual torque adjustment values.
 F1: Decreases the set value.
 F2: Increases the set value.
 F4: Validates or enters the setting, and the screen goes back to "Adjustment" screen.

REMARK

The 3-digit number in the left column does not change. This is the code for this function.



G0182050

Relational Table of Set Values and Torque Adjustment Values

Code	Set value	Torque adjustment value
021	000	+14.7Nm {+1.5kgfm}
	001	+9.8Nm {+1.0kgfm}
	002	+4.9Nm {+0.5kgfm}
	003	0Nm {0kgfm}
	004	-4.9Nm {-0.5kgfm}
	005	-9.8Nm {-1.0kgfm}
	006	-14.7Nm {-1.5kgfm}

3. Remove the nuts (2) (2 pieces) of the contactor part, and remove the slow-blow fuse (3).

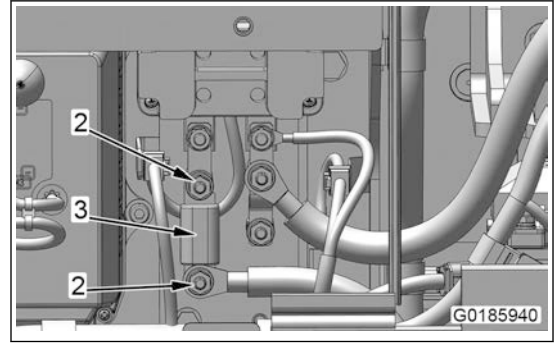
**Check procedure**

4. Do a continuity test with a multimeter to see if the fuse is blown. If the fuse is blown, replace it with a fuse of the same capacity.

REMARK

For the fuse capacity and related electrical components, see Troubleshooting, "Fuse Location Table".

Restoration

5. Install the slow-blow fuse (3), and install the nuts (2) (2 pieces) of the contactor part.
 Tightening torque of nut (2): 12.7 to 14.7Nm {1.3 to 1.5kgfm}
6. Install the cover (1).
7. Restore the data. See Index and Foreword, "Procedure to Restore High Voltage Parts".

Failure Code [D6L5KR]	40-149
Failure Code [D6L6MA]	40-150
Failure Code [D6L7MA]	40-151
Failure Code [D6L8KR]	40-152
Failure Code [D6L9KR]	40-153
Failure Code [D6LBNS]	40-154
Failure Code [D6LCNS]	40-155
Failure Code [D6LDNS]	40-156
Failure Code [D6LENS]	40-157
Failure Code [D6LFKA]	40-158
Failure Code [D6LGKA]	40-159
Failure Code [D6LHNS]	40-160
Failure Code [D6LJNS]	40-161
Failure Code [D6LKKA]	40-162
Failure Code [D6LLKA]	40-163
Failure Code [D6LMKA]	40-164
Failure Code [D6LNKA]	40-165
Failure Code [D6LPNS]	40-166
Failure Code [D811MC]	40-167
Failure Code [D862KA]	40-168
Failure Code [D8ALKA]	40-169
Failure Code [D8ALKB]	40-171
Failure Code [D8AQKR]	40-173
Failure Code [DAF0KT]	40-179
Failure Code [DAF0MB]	40-180
Failure Code [DAF0MC]	40-181
Failure Code [DAF3KK]	40-182
Failure Code [DAF9KQ]	40-184
Failure Code [DAFGMC]	40-185
Failure Code [DAFLKA]	40-186
Failure Code [DAFLKB]	40-188
Failure Code [DAFQKR]	40-190
Failure Code [DBH0MC]	40-196
Failure Code [DBH2KK]	40-197
Failure Code [DBH2KT]	40-200
Failure Code [DBH3KK]	40-202
Failure Code [DBH5KP]	40-204
Failure Code [DBH6KP]	40-207
Failure Code [DBH9KQ]	40-210
Failure Code [DBHJKT]	40-212
Failure Code [DBHJKY]	40-213
Failure Code [DBHKA]	40-214
Failure Code [DBHKB]	40-215
Failure Code [DBHKY]	40-216
Failure Code [DBHLKA]	40-217
Failure Code [DBHLKB]	40-219
Failure Code [DBHPKR]	40-221
Failure Code [DBHQKR]	40-225
Failure Code [DBHRKR]	40-231
Failure Code [DBHTKA]	40-236
Failure Code [DBHTKB]	40-238
Failure Code [DBHTKY]	40-240
Failure Code [DDNRKA]	40-242
Failure Code [DDNRKY]	40-244
Failure Code [DDNS00]	40-246
Failure Code [DDWLKA]	40-248
Failure Code [DDWLKB]	40-250
Failure Code [DF40KZ]	40-252

2. Loosen the bolt (3), and slide the plate (4) on the upper surface of the filler port (F).
3. Turn the cap of the filler port (F) slowly to release the internal pressure.
4. Remove the cap of the filler port (F).

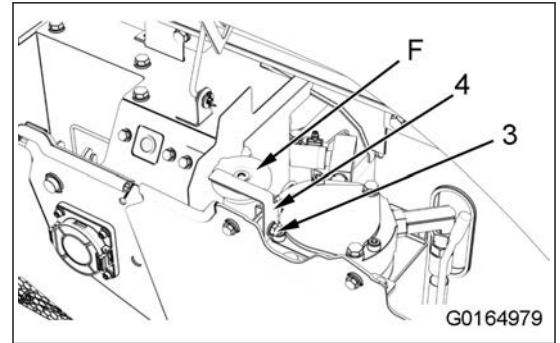

5. Put the container to receive the drained oil below the drain plug (P) on the lower side of the machine.
6. Use a handle for socket wrench to remove the drain plug (P). Drain oil.

Be careful not to be splashed with oil.

7. Make sure that there is no damage on the O-ring of the drain plug (P).

If there is damage, replace it with a new O-ring.

8. Install the drain plug (P).

Tightening torque: 58.8 to 78.5Nm {6 to 8kgfm}

9. Open the floor.

For detail, see Testing and Adjusting, "How to Open and Close Floor".

10. Remove the bolt (5) (M10).

11. Loosen the hose clamp (6), and disconnect the hose (7).

12. Loosen the 4 bolts (8) (M10), and remove the strainer (9).

13. Remove the dirt from the strainer (9), and then wash it in the clean diesel fuel or flushing oil.

If there is damage, replace it with a new strainer.

14. Secure the strainer (9) with the 4 bolts (8) (M10).

15. Connect the hose (7), and secure it with the hose clamp (6).

16. Install the bolt (5) (M10).

17. Close the floor.

For detail, see Testing and Adjusting, "How to Open and Close Floor".

18. Add oil through the filler port (F).

19. Examine the oil level.

For details, see "Examine Hydraulic Oil Level".

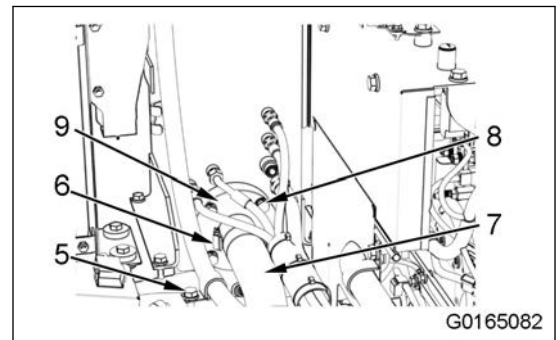
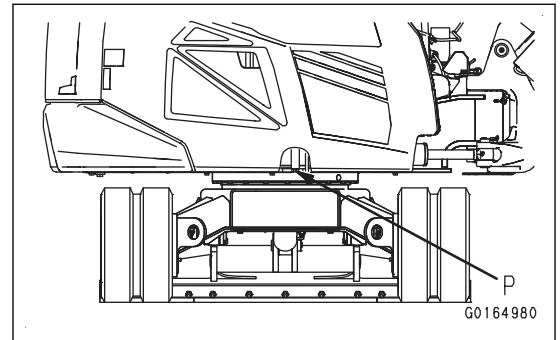

NOTICE

Be sure to bleed air from the hydraulic circuit after the work. If not, air is sucked into the pump. It causes harmful effects on the equipment.

For details, see Testing and Adjusting, "Pressurize Hydraulic Tank".

Symptom and Troubleshooting Numbers

No.	Symptom and troubleshooting numbers	Troubleshooting
		Index
Action level, failure code		
1	Action level is shown on the machine monitor. Push the switch F3 to show "Current Abnormality".	Do the troubleshooting for the failure code.
2	Failure code is shown on "Mechanic Sys Error Record".	
3	Failure code is shown on "Electric Sys Error Record".	
Electric motor		
4	Electric Motor Does Not Start (Electric Motor Does Not Run)	E-1
5	Auto-Decelerator is Not Operated or Canceled with Lever	E-2
Work equipment, swing, travel, overall blade		
6	All Work Equipment, Travel, Swing, Blade Do Not Operate	H-1
7	All Work Equipment or Travel Does Not Operate	H-2
8	Travel and Blade Do Not Operate	H-3
9	Swing and Blade Do Not Operate	H-4
10	All Work Equipment, Travel, Swing and Blade Speed or Power is Low	H-5
11	All Work Equipment and Travel Speed or Power is Low	H-6
12	Travel and Blade Speed or Power is Low	H-7
13	Swing and Blade Speed or Power is Low	H-8
14	Fine Control Performance or Response is Unsatisfactory	H-9
15	There is an Unusual Noise from Around Main Pump	H-10
16	Electric Motor Speed Drops Largely or Electric Motor Does Not Run	H-11
17	When Working Mode is Changed, Setting of Electric Motor and Hydraulic Pump is Not Changed	E-3
18	All Work Equipment, Swing, Travel Do Not Operate	E-4
19	All Work Equipment, Swing, Travel Cannot be Locked	E-5
Work equipment		
20	All Work Equipment Speed or Power is Low	H-12
21	All Work Equipment and Blade Speed or Power is Low	H-13
22	All Work Equipment Do Not Operate	H-15
23	All Work Equipment and Blade Do Not Operate	H-16
24	Boom Speed or Power is Low	H-17
25	Arm Speed or Power is Low	H-18
26	Bucket Speed or Power is Low	H-19
27	Boom Swing Speed or Power is Low	H-21
28	Work Equipment Does Not Move in Single Operation	H-22
29	Hydraulic Drift of Boom is Large	H-23
30	Hydraulic Drift of Arm is Large	H-24
31	Hydraulic Drift of Bucket is Large	H-25

Connector Contact Connection Table

(Rev. 2023.08)

Male and female refer to the gender of the pin portion. Convex and concave refer to the shape of the engaging portion (housing).

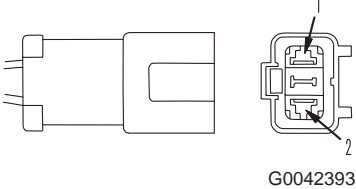
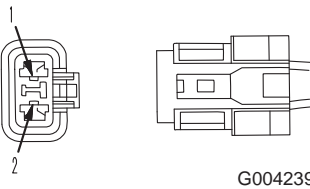
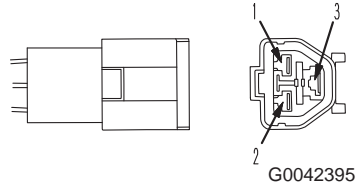
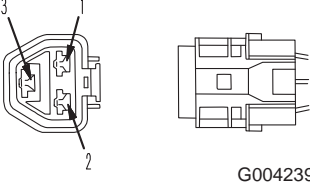
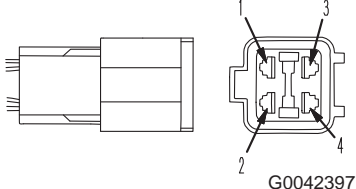
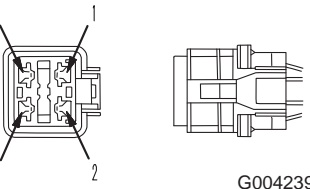
Total number of pins	X type connector		Special tool number for connection checks
	Male (concave engaging portion)	Female (convex engaging portion)	
1	Part No.: 08055-00181	Part No.: 08055-00191	799-601-7010 (T-branch)
2	 <p>G0042393</p>	 <p>G0042394</p>	799-601-7020 (T-branch)
	Part No.: 08055-00282	Part No.: 08055-00292	
3	 <p>G0042395</p>	 <p>G0042396</p>	799-601-7030 (T-branch)
	Part No.: 08055-00381	Part No.: 08055-00391	
4	 <p>G0042397</p>	 <p>G0042398</p>	799-601-7040 (T-branch)
	Part No.: 08055-00481	Part No.: 08055-00491	
-	Terminal part number: 79A-222-3370 <ul style="list-style-type: none"> • Wire size: 0.85 • Grommet: Black • Q'ty: 20 	Terminal part number: 79A-222-3390 <ul style="list-style-type: none"> • Wire size: 0.85 • Grommet: Black • Q'ty: 20 	-
-	Terminal part number: 79A-222-3380 <ul style="list-style-type: none"> • Wire size: 2.0 • Grommet: Red • Q'ty: 20 	Terminal part number: 79A-222-3410 <ul style="list-style-type: none"> • Wire size: 2.0 • Grommet: Red • Q'ty: 20 	-

Total number of pins	Connector for relay (socket)		Special tool number for connection checks
	Female (convex engaging portion)	Relay (concave engaging portion)	
5	<p>G0042483</p>	<p>G0042484</p>	799-601-7360 (T-branch)
	-	-	
6	<p>G0042485</p>	<p>G0042486</p>	799-601-7370 (T-branch)
	-	-	
5	<p>G0042487</p>	<p>G0042488</p>	-
	Part No.: 7861-74-5300	Part No.: 7861-74-5100 3BB-56-63210	
	<p>G0042489</p>	<p>G0042490</p>	
-	-	Part No.: RD-5-4417-OP	
5	<p>G0179603</p>	<p>G0179604</p>	-
	-	Part No.: 20Y-979-6771	

JAE connector (for inverter, power supply controller)			
Total number of pins	Controller side (plug)	Harness side (receptacle)	Special tool number for connection checks
36			-
	-	-	

Total number of pins	SRC connector		Special tool number for connection checks
	Male (concave engaging portion)	Female (convex engaging portion)	
66	<p>Part No.: 08195-51000</p>	<p>Part No.: 08195-52000</p>	-
-	Pin part number: 08195-03100 • Wire size: 0.3	Terminal part number: 08195-04100 • Wire size: 0.3	-
-	Pin part number: 08195-03200 • Wire size: 0.5, 0.75, 0.85	Terminal part number: 08195-04200 • Wire size: 0.5, 0.75, 0.85	-
-	Pin part number: 08195-03300 • Wire size: 1.25, 2	Terminal part number: 08195-04300 • Wire size: 1.25, 2	-
-	Pin part number: 08195-03400 • Wire size: 2 (AVS)	Terminal part number: 08195-04400 • Wire size: 2 (AVS)	-
-	Pin part number: 08195-03500 • Wire size: 3, 5	Terminal part number: 08195-04500 • Wire size: 3, 5	-
-	Pin part number: 08195-03600 • Wire size: 8	Terminal part number: 08195-04600 • Wire size: 8	-

Failure Code Table

Failure code	Failure (Shown on screen)	Applicable equipment	Action level	History category	Remarks
989L00	Engine Controller Lock Caution 1	MON	-	Electrical system	
989M00	Engine Controller Lock Caution 2	MON	-	Electrical system	
989N00	Engine Controller Lock Caution 3	MON	-	Electrical system	
B@HANS	Hyd Oil Overheat	MACHINE	L02	Mechanical system	
D105KA	Electric Fan Relay Low Speed Order Open Circuit	MACHINE	L01	Electrical system	
D105KB	Electric Fan Relay Low Speed Order Ground Fault	MACHINE	L01	Electrical system	
D105KY	Elec Fan Relay Low Speed Order Hot Short Circuit	MACHINE	L01	Electrical system	
D19JKZ	Personal Code Relay Open Circuit or Short Circuit	MON	L03	Electrical system	
D19ZKA	ElecMotor Oper RevLight Relay Drive Open Circuit	MACHINE	L01	Electrical system	
D19ZKB	ElecMotor Oper RevLight Relay Drive Ground Fault	MACHINE	L01	Electrical system	
D19ZKZ	ElecMotor Oper RevLight Relay Drive Short Circuit	MACHINE	L01	Electrical system	
D1HBKA	DISC) Main Contactor2	MACHINE	L04	Electrical system	
D1HBKB	GROUND FAULT) Main Contactor2	MACHINE	L04	Electrical system	
D1HBKY	SHORT_P) Main Contactor2	MACHINE	L03	Electrical system	
D610KF	TIME-UP) CHARGING START	MACHINE	L03	Electrical system	
D6L1KA	DISC) CHRGR RLY	MACHINE	L03	Electrical system	
D6L1KB	SHORT_P) CHRGR RLY	MACHINE	L01	Electrical system	
D6L2KA	DISC) DIS CHRGR RLY	MACHINE	L03	Electrical system	
D6L2KB	SHORT_P) DIS CHRGR RLY	MACHINE	L01	Electrical system	
D6L3KB	SHORT_P) HEATER RLY	MACHINE	L01	Electrical system	
D6L4KT	ABNL) SAVING DATA (BMS)	MACHINE	L03	Electrical system	
D6L5KE	TIME-UP) CHARGING END	MACHINE	L03	Electrical system	

No.	Cause	Procedure, measuring location, criteria, and remarks
4	Defective machine controller	If no failure is found by above checks, the machine controller is defective. (Because this is an internal defect, the troubleshooting cannot be done.)

Circuit Diagram of Hydraulic Oil Temperature Sensor

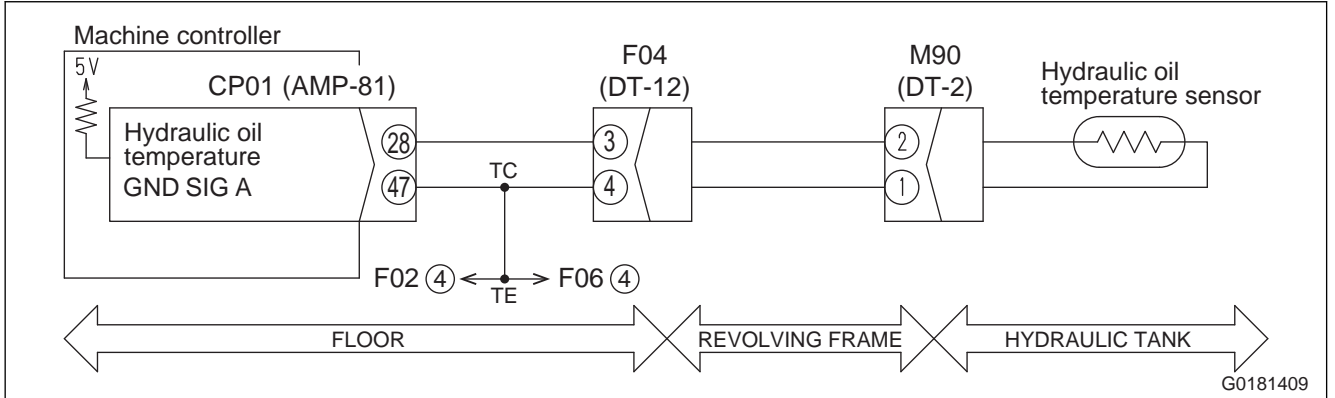

Circuit Diagram of Electric Motor Operation Lamp Relay

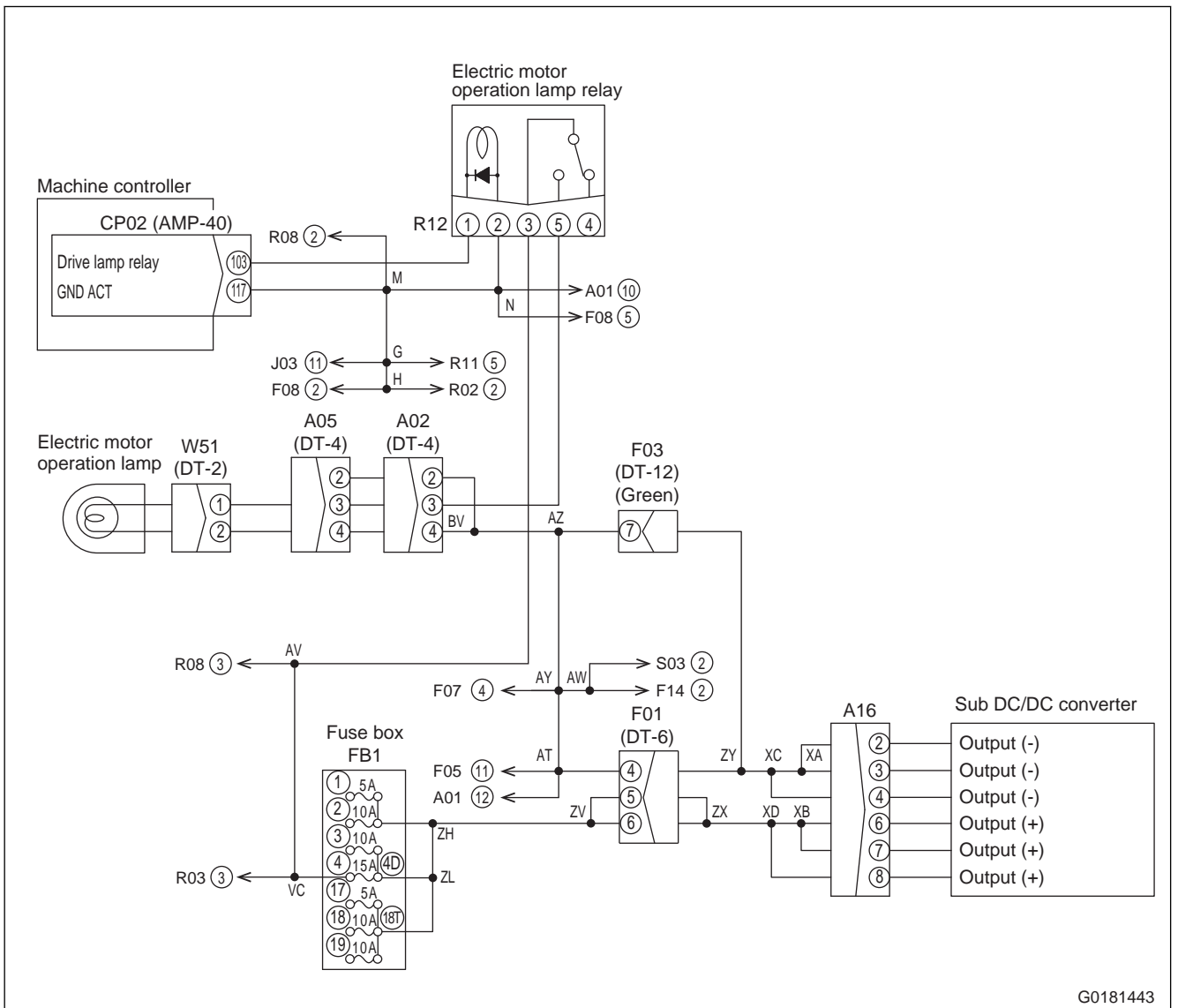

G0181443

Failure Code [D6L2KA]

Action level	Failure code	Failure	DISC) DIS CHRGR RLY (BMS system)
L03	D6L2KA		
Details of failure	When the discharge relay in the BMS box is ON, a voltage difference before and after the discharge relay of 5V or more is sensed for 5 seconds.		
Action of controller	<ul style="list-style-type: none"> During operation, shows a warning on the machine monitor, and operates the alarm buzzer. After the machine stops, turns off the discharge relay. During a charge, it stops the charge. 		
Phenomenon on machine	<ul style="list-style-type: none"> During operation, the machine power supply is turned off. Travel, swing, and work equipment cannot be operated. Charge is not possible. 		
Related information	<ul style="list-style-type: none"> When this failure is sensed, the machine power supply is turned off automatically. The failure code is shown when the special power supply for battery is turned from OFF to ON manually. If the discharge relay is fully open because of a failure, the machine power supply will not turn on. After the repair is done, make sure that the failure code is not shown with the operation that follows. Procedure: Turn on the special power supply for battery. Turn the starting switch to the ON position. 		

No.	Cause	Procedure, measuring location, criteria, and remarks	
1	Discharge relay is open	1. Turn the starting switch to the OFF position. 2. Make sure that the system operating lamp does not come on. Turn the special power supply for battery to the OFF position. (Wait for 10 minutes or more.) 3. Disconnect the battery plugs W50 and W60 and do the troubleshooting on the BMS side. ⚠ If the voltage is measured on the battery plug, personal injury or death can be caused by electric shock. Be sure to refer the Testing and Adjusting, "Measure Battery Voltage", and obey the content to measure.	
		Voltage	Between battery plug (BMS side) W50 positive contact and W60 negative contact
2	The BMS board is defective.	The circuit board is defective. (Because this is an internal defect, the troubleshooting cannot be done.)	

Failure Code [D6LENS]

Action level	Failure code	Failure	ABNL HIGH Temp.) MPACK1+ (BMS system)
L03	D6LENS		
Details of failure	The temperature sensed by the temperature sensor on the positive side of battery pack 1 is 90°C or more.		
Action of controller	<ul style="list-style-type: none"> • During operation, shows a warning on the machine monitor, operates the alarm buzzer, and stops the machine. • During charge, stops the charge. 		
Phenomenon on machine	<ul style="list-style-type: none"> • Travel, swing, and work equipment cannot be operated. • Charge is not possible. 		
Related information	After the repair is done, make sure that the failure code is not shown with the operation that follows. Procedure: Turn on the special power supply for battery. Turn the starting switch to the ON position.		

No.	Cause	Procedure, measuring location, criteria, and remarks
1	Strong-electricity cable halfway engaged	Make sure the cable is pushed into the connector until it is locked.
2	Loose wiring in positive connector	The wiring to the positive connector is loose. (Because this is an internal defect, the troubleshooting cannot be done.)
3	Defective temperature sensor (short circuit)	The temperature sensor has a short circuit. (Because this is an internal defect, the troubleshooting cannot be done.)

Failure Code [D8ALKB]

Action level	Failure code	Failure phenomenon	System Operating Lamp Short Circuit (KOMTRAX) (KOMTRAX system)
-	D8ALKB		
Details of failure	The KOMTRAX senses a short circuit because the output voltage does not become low level while it outputs current to the system operating lamp.		
Action of controller	Stops the output to the system operating lamp.		
Phenomenon on machine	When this failure code is active or shown in the abnormality record, the system operating lamp is turned off constantly.		
Related information	<p>NOTICE</p> <p>If this failure code is shown, it does not become possible to make sure that each controller stops normally with the system operating lamp. Be sure to turn the starting switch to the OFF position, wait for 10 minutes or more, and then turn the power supply for battery to the OFF position. If the power supply for the battery is turned to the OFF position before each controller stops correctly, the recorded data in KOMTRAX can be broken.</p> <ul style="list-style-type: none"> The system operating lamp cannot be operated from the KOMTRAX. But, there is no problem unless the power supply for the battery is turned to the OFF position. When the system operating lamp is on, the output voltage is at low level. After the repair is done, make sure that the failure code is not shown with the operation that follows. <p>Procedure: Turn on the special power supply for battery. Turn the starting switch to the ON position.</p>		

No.	Cause	Procedure, measuring location, criteria, and remarks		
1	Short circuit in wiring harness	1. Turn the starting switch to the OFF position. (Wait for 10 minutes or more.)		
		2. Turn off the special power supply for battery. (Wait at least 10 more minutes.)		
		3. Disconnect the connectors CC01, CK01, CL3, CP02, F15, F31, F37, and M22. Connect a T-adaptor to female side of M22 to do the troubleshooting.		
		Resistance	Between M22 (female) (1) and (2)	Min. 1MΩ
2	Defective KOMTRAX terminal	If no failure is found by above checks, the KOMTRAX terminal is defective. (Because this is an internal defect, the troubleshooting cannot be done.)		

Failure Code [DAFGMC]

Action level	Failure code	Failure phenomenon	GPS Module Malfunction (KOMTRAX system)
-	DAFGMC		
Details of failure	The KOMTRAX terminal senses malfunction of the GPS module.		
Action of controller	None.		
Phenomenon on machine	KOMTRAX system does not operate correctly.		
Related information	<ul style="list-style-type: none"> The abnormality is not sent to the machine monitor. After the repair is done, make sure that the failure code is not shown with the operation that follows. Procedure: Turn on the special power supply for battery. Turn the starting switch to the ON position.		
No.	Cause	Procedure, measuring location, criteria, and remarks	
1	Defective GPS module	The GPS module of the KOMTRAX terminal is defective. (Because this is an internal defect, the troubleshooting cannot be done.)	

Circuit Diagram of Machine Controller Solenoid Power Supply

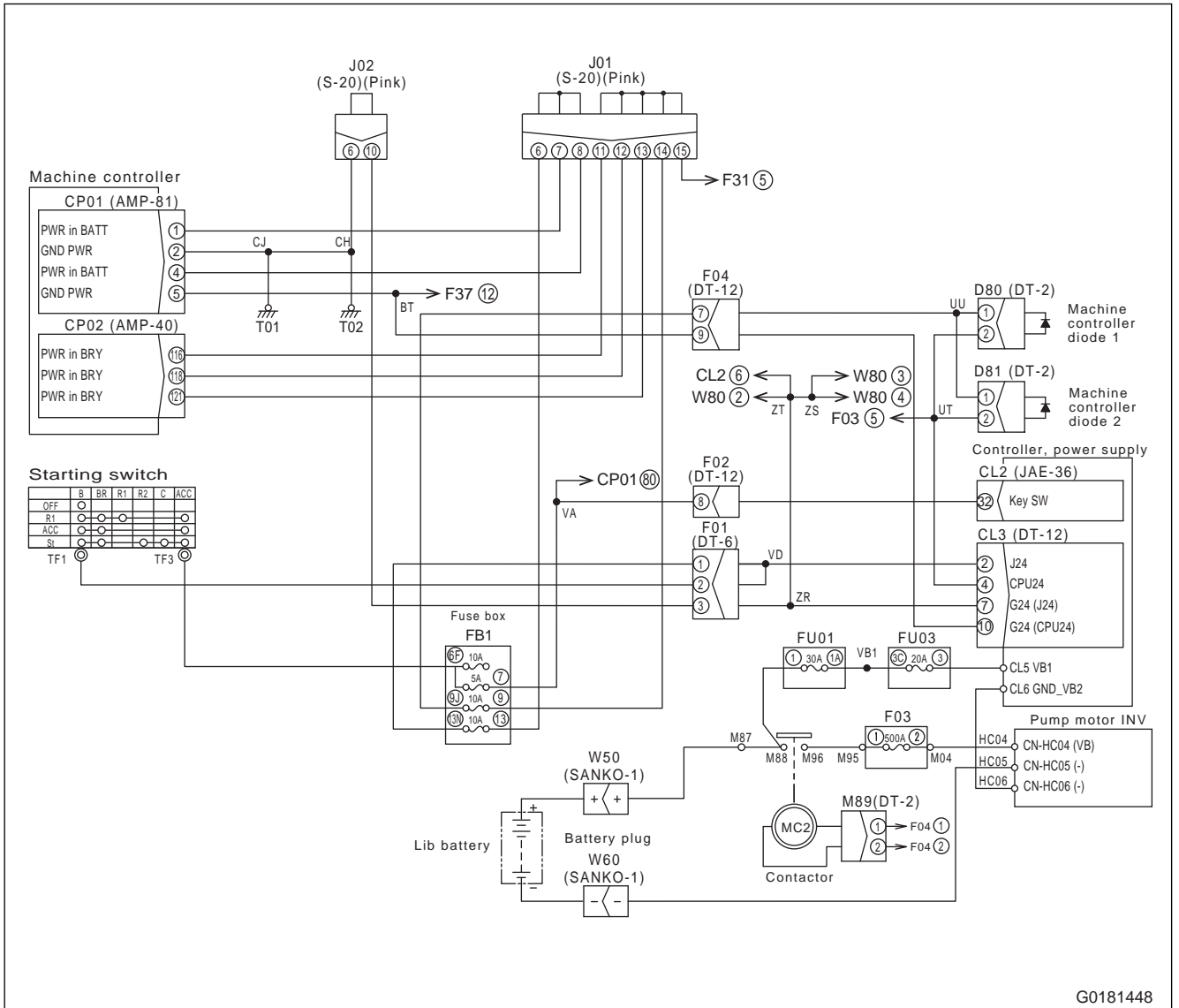

G0181448

Failure Code [DBHJKY]

Action level	Failure code	Failure phenomenon	Mach Controller Sol Return Circ Hot Short Circuit (Machine controller system)
L03	DBHJKY		
Details of failure	A hot short circuit is sensed in the solenoid return circuit.		
Action of controller	Blocks the ATT flow rate adjustment EPC return circuit.		
Phenomenon on machine	None		
Related information	After the repair is done, make sure that the failure code is not shown with the operation that follows. Procedure: Turn on the special power supply for battery. Turn the starting switch to the ON position.		
No.	Cause	Procedure, measuring location, criteria, and remarks	
1	Defective machine controller	The machine controller is defective. (Because this is an internal defect, the troubleshooting cannot be done.)	

CLICK HERE TO **DOWNLOAD** THE COMPLETE MANUAL

- Thank you very much for reading the preview of the manual.
- You can download the complete manual from: www.heydownloads.com by clicking the link below



- Please note: If there is no response to CLICKING the link, please download this PDF first and then click on it.

CLICK HERE TO **DOWNLOAD** THE COMPLETE MANUAL

No.	Cause	Procedure, measuring location, criteria, and remarks		
6	Open circuit in wiring harness (CAN2 communication circuit)	1. Turn the starting switch to the OFF position. 2. Make sure that the system operating lamp does not come on. Turn the special power supply for battery to the OFF position. (Wait for 10 minutes or more.) 3. Disconnect the connectors CP01 and F15. Connect a T-adapter to each female side to do the troubleshooting.		
		Resistance	Between CP01 (female) (45) and F15 (female) (11)	Max. 1Ω
			Between CP01 (female) (64) and F15 (female) (12)	Max. 1Ω
			Between CP01 (female) (45) and K02 (female) (A)	Max. 1Ω
			Between CP01 (female) (64) and K02 (female) (B)	Max. 1Ω
7	Ground fault in wiring harness (CAN2 communication circuit)	1. Turn the starting switch to the OFF position. 2. Make sure that the system operating lamp does not come on. Turn the special power supply for battery to the OFF position. (Wait for 10 minutes or more.) 3. Disconnect the connectors CANC, CC01, CK01, CP01, F15, F31, F37, and K02. Connect the T-adapter to the female side to do the troubleshooting.		
		Resistance	Between T01 and one of CANC (female) (1), CC01 (female) (3), CK01 (female) (10), CP01 (female) (45), F15 (female) (11), F31 (female) (6), F37 (female) (3), K02 (female) (A)	Min. 1MΩ
			Between T01 and one of CANC (female) (2), CC01 (female) (9), CK01 (female) (11), CP01 (female) (64), F15 (female) (12), F31 (female) (7), F37 (female) (10), K02 (female) (B)	Min. 1MΩ
8	Short circuit in wiring harness (CAN2 communication circuit)	1. Turn the starting switch to the OFF position. 2. Make sure that the system operating lamp does not come on. Turn the special power supply for battery to the OFF position. (Wait for 10 minutes or more.) 3. Disconnect the connectors CANC, CC01, CK01, F15, F31, F37, and K02. Connect a T-adapter to the female side of CP01 to do the troubleshooting.		
		Resistance	Between CP01 (female) (45) and each pin other than pin (45)	Min. 1MΩ
			Between CP01 (female) (64) and each pin other than pin (64)	Min. 1MΩ
9	Hot short circuit in wiring harness (CAN2 communication circuit)	1. Turn the starting switch to the OFF position. 2. Make sure that the system operating lamp does not come on. Turn the special power supply for battery to the OFF position. (Wait for 10 minutes or more.) 3. Disconnect the connector K02. Connect a T-adapter to the female side. 4. Turn on the special power supply for battery. 5. Turn the starting switch to the ON position to do the troubleshooting.		
		Voltage	Between K02 (female) (A) and T01	Max. 4V
			Between K02 (female) (B) and T01	Max. 4V

Circuit Diagram of ENABLE Command of Sub DC/DC Converter

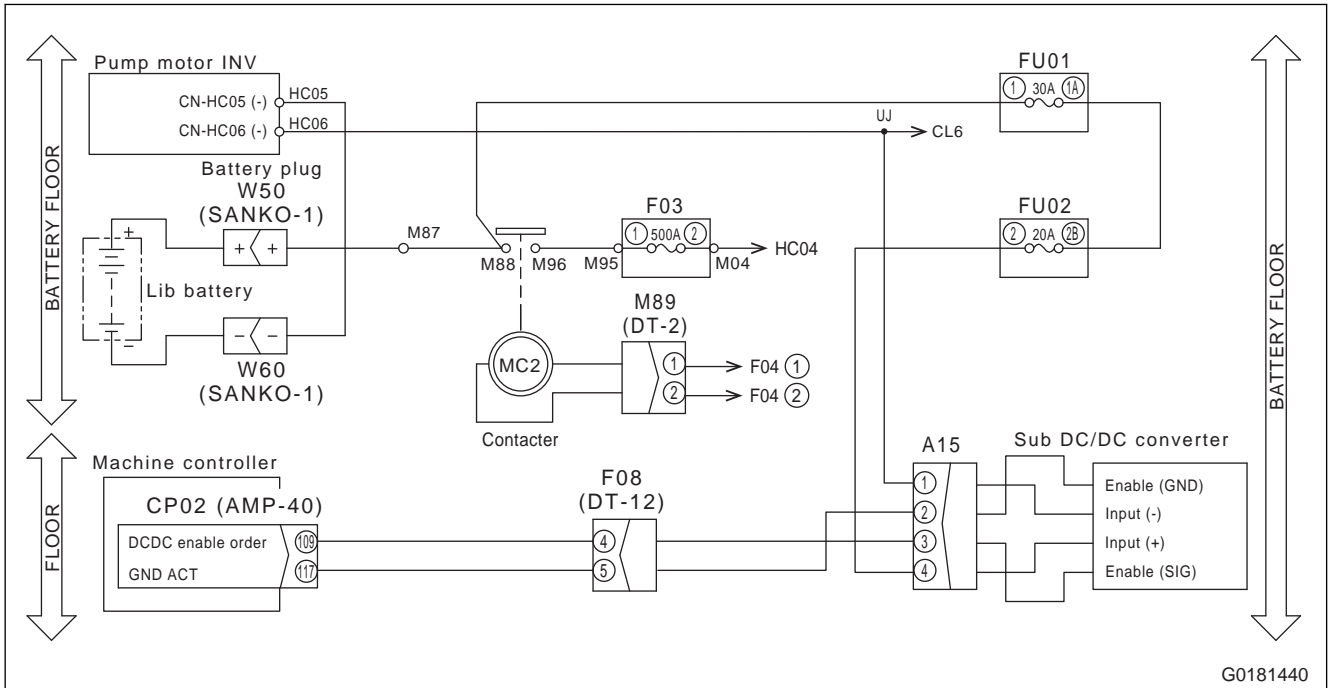

Failure Code [DFB1KZ]

Action level	Failure code	Failure phenomenon	Service Lever Potentio 1 Open or Short Circuit (Machine controller system)
L01	DFB1KZ		
Details of failure	When you operate the machine, the machine senses an error of the attachment proportional switch of the service lever 1 (right lever).		
Action of controller	<ul style="list-style-type: none"> Stops the output to the attachment flow rate adjustment EPC2 solenoid. Stops the output to the attachment flow rate adjustment EPC5 solenoid. 		
Phenomenon on machine	The attachment cannot be operated.		
Related information	<ul style="list-style-type: none"> This failure code can only be sensed when it is set to "With Attachment 1" or "With Attachment 2". The service lever 1 (right lever) potentiometer 1 signal voltage can be examined with the monitoring function. (Code: 42008) After the repair is done, make sure that the failure code is not shown with the operation that follows. Procedure: Turn on the special power supply for battery. Turn the starting switch to the ON position and set the attachment selection mode. 		

No.	Cause	Procedure, measuring location, criteria, and remarks		
1	5V sensor power output 1 error	If "Failure Code [DBH5KP]" is shown at the same time, do the troubleshooting for it first.		
2	Open circuit in wiring harness	<ol style="list-style-type: none"> Turn the starting switch to the OFF position. Make sure that the system operating lamp does not come on. Turn the special power supply for battery to the OFF position. (Wait for 10 minutes or more.) Disconnect the connectors CP01 and F26. Connect a T-adaptor to each female side to do the troubleshooting. 		
		Resistance	Between CP01 (female) (14) and F26 (female) (5)	Max. 1Ω
			Between CP01 (female) (6) and F26 (female) (2)	Max. 1Ω
			Between CP01 (female) (18) and (6)	4.0 to 6.0kΩ
			Between CP01 (female) (14) and (18)	0.25 to 5.0kΩ
Between CP01 (female) (14) and (6)	0.25 to 5.0kΩ			
3	Ground fault in wiring harness (contact with ground circuit)	<ol style="list-style-type: none"> Turn the starting switch to the OFF position. Make sure that the system operating lamp does not come on. Turn the special power supply for battery to the OFF position. (Wait for 10 minutes or more.) Disconnect the connectors CP01 and F26. Connect a T-adaptor to the female side of CP01 to do the troubleshooting. 		
		Resistance	Between CP01 (female) (14) and T01	Min. 1MΩ

Failure Code [DHS5MA]

Action level	Failure code	Failure phenomenon	Travel PPC Pressure Sensor Error (Machine controller system)
L01	DHS5MA		
Details of failure	The signal voltage of the travel PPC pressure sensor circuit is 0.3V and below or 4.5V and more.		
Action of controller	<ul style="list-style-type: none"> Controls the travel PPC pressure sensor as 0MPa {0kgf/cm²}. When the cause of failure is corrected, the machine will go back to the correct state. 		
Phenomenon on machine	<ul style="list-style-type: none"> The auto-deceleration function cannot be canceled. Operation performance of travel becomes slow. 		
Related information	<p>NOTICE</p> <p>If the 5V circuit (3) and the ground circuit (1) of the pressure sensor are connected reversely. It can cause damage to the pressure sensor. Be very careful during the check.</p> <ul style="list-style-type: none"> The travel PPC pressure can be examined with the monitoring function. (Code: 07101) Because the T-adaptor is "Socket type box" at the connector of the machine controller, the operating voltage of machine controller side cannot be measured. After the repair is done, make sure that the failure code is not shown with the operation that follows. Procedure: Turn on the special power supply for battery. Turn the starting switch to the ON position. 		

No.	Cause	Procedure, measuring location, criteria, and remarks		
1	Defective 5V sensor power supply 1 system	If "Failure Code [DBH5KP]" is shown at the same time, do the troubleshooting for it first.		
2	Open circuit in wiring harness (wire breakage or defective contact of connector)	1. Turn the starting switch to the OFF position.		
		2. Make sure that the system operating lamp does not come on. Turn the special power supply for battery to the OFF position. (Wait for 10 minutes or more.)		
		3. Disconnect the connectors CP01 and P02. Connect a T-adaptor to each female side to do the troubleshooting.		
		Resistance	Between CP01 (female) (6) and P02 (female) (3)	Max. 1Ω
		Between CP01 (female) (47) and P02 (female) (1)	Max. 1Ω	
		Between CP01 (female) (29) and P02 (female) (2)	Max. 1Ω	
3	Ground fault in wiring harness (contact with ground circuit)	1. Turn the starting switch to the OFF position.		
		2. Make sure that the system operating lamp does not come on. Turn the special power supply for battery to the OFF position. (Wait for 10 minutes or more.)		
		3. Disconnect the connectors CP01 and P02. Connect a T-adaptor to the female side of one of them to do the troubleshooting.		
	Resistance	Between T01 and one of CP01 (female) (29) and P02 (female) (2)	Min. 1MΩ	

Failure Code [DV00KB]

Action level	Failure code	Failure phenomenon	Buzzer Output Short Circuit (Machine monitor system)
L01	DV00KB		
Details of failure	When the output to the alarm buzzer circuit is ON, an abnormal current flows through the circuit.		
Action of controller	<ul style="list-style-type: none"> Stops the output to the alarm buzzer circuit. If the starting switch is turned to the OFF position one time after the cause of the failure is removed, the machine will go back to the correct state. 		
Phenomenon on machine	Alarm buzzer does not make sound.		
Related information	None		

No.	Cause	Procedure, measuring location, criteria, and remarks
1	Defective machine monitor	The machine monitor is defective. (Because this is an internal defect, the troubleshooting cannot be done.)

Failure Code [DXA8KB]

Action level	Failure code	Failure phenomenon	Pump PC-EPC Solenoid Short Circuit (Machine controller system)
L03	DXA8KB		
Details of failure	When the pump PC-EPC solenoid is energized, a short circuit is sensed because an abnormal current flows through the circuit.		
Action of controller	<ul style="list-style-type: none"> Stops the output to the pump PC-EPC solenoid. If the starting switch is turned to the OFF position one time after the cause of the failure is removed, the machine will go back to the correct state. 		
Phenomenon on machine	If the pump load is increased, the motor speed falls largely and the motor can stop.		
Related information	<ul style="list-style-type: none"> If the solenoid and wiring harness have no abnormality, set the pump secondary drive switch to the emergency position (upper side) to prevent the stop of the hydraulic oil pump. Drive current of the pump PC-EPC solenoid can be examined with the monitoring function. (Code: 01300) After the repair is done, make sure that the failure code is not shown with the operation that follows. Procedure: Turn on the special power supply for battery. Turn the starting switch to the ON position. 		

No.	Cause	Procedure, measuring location, criteria, and remarks			
1	Defective PC-EPC solenoid (internal short circuit, ground fault)	<ol style="list-style-type: none"> Turn the starting switch to the OFF position. Make sure that the system operating lamp does not come on. Turn the special power supply for battery to the OFF position. (Wait for 10 minutes or more.) Disconnect the connector M11. Connect a T-adapter to the male side to do the troubleshooting. 			
		Resistance	Between M11 (male) (1) and (2)	3 to 14Ω	
			Between M11 (male) (1) and T01	Min. 1MΩ	
2	Defective pump secondary drive switch (internal short circuit, ground fault)	<ol style="list-style-type: none"> Turn the starting switch to the OFF position. Make sure that the system operating lamp does not come on. Turn the special power supply for battery to the OFF position. (Wait for 10 minutes or more.) Disconnect the connector S25. Connect a T-adapter to the male side to do the troubleshooting. 			
		Resistance	Between S25 (male) (2), (3) and (5)	Switch position: Normal	Min. 1MΩ
			Between T01 and each of S25 (male) (2) and (3)	Switch position: Normal	Min. 1MΩ

Failure Code [F7FQKR]

Action level	Failure code	Failure phenomenon	CAN 2 Discon (ID Key Con) (Machine monitor system)
L03	F7FQKR		
Details of failure	The machine monitor cannot receive communication from the ID key continuously for 3 seconds.		
Action of controller	<ul style="list-style-type: none"> Turns off the output to the inverter because the signal from the ID key controller cannot be received and the machine cannot make a judge to start. If the starting switch is turned to the OFF position one time after the cause of the failure is removed, the machine will go back to the correct state. 		
Phenomenon on machine	<ul style="list-style-type: none"> You cannot do operations such as new registration or deletion of ID keys. If it occurs when the starting switch is turned to the ON position, you cannot travel or swing the machine, or operate the work equipment. 		
Related information	<ul style="list-style-type: none"> If “Failure Code [D8AQKR]” and “Failure Code [DBHQKR]” are shown at the same time, the machine controller or the KOMTRAX terminal can be defective. The ACC signal of the starting switch tells each controller and machine monitor that CAN communication is started with the CPU24 signal output by the power supply controller. Because of the continuous power supply, each controller and machine monitor are supplied with power even after the starting switch is turned to the OFF position. Because the signal of an active CAN2 communication line is pulse voltage, it cannot be measured with a multimeter. The termination resistance of 120Ω on the CAN communication line is found in K02 and the machine monitor. After the repair is done, make sure that the failure code is not shown with the operation that follows. Procedure: Turn on the special power supply for battery. Turn the starting switch to the ON position. 		

No.	Cause	Procedure, measuring location, criteria, and remarks		
1	Defective power supply to ID key controller	<ol style="list-style-type: none"> Turn the starting switch to the OFF position. Make sure that the system operating lamp does not come on. Turn the special power supply for battery to the OFF position. (Wait for 10 minutes or more.) Disconnect the connector CC01. Connect a T-adaptor to the female side. Turn on the special power supply for battery. Turn the starting switch to the ON position to do the troubleshooting. If the voltage shown below is abnormal, the wiring harness is defective.		
		Voltage	Between CC01 (female) (1) and (7)	Approx. 24V
2	Open circuit in wiring harness (Power supply circuit to ID key controller)	<ol style="list-style-type: none"> Turn the starting switch to the OFF position. Make sure that the system operating lamp does not come on. Turn the special power supply for battery to the OFF position. (Wait for 10 minutes or more.) Remove fuse No.13 in fuse box FB1. Disconnect the connector CC01. Connect a T-adaptor to the female side to do the troubleshooting. 		
		Resistance	Between CC01 (female) (1) and FB1-13	Max. 1Ω
			Between CC01 (female) (7) and T01	Max. 1Ω

Circuit Diagram of System Start Signal

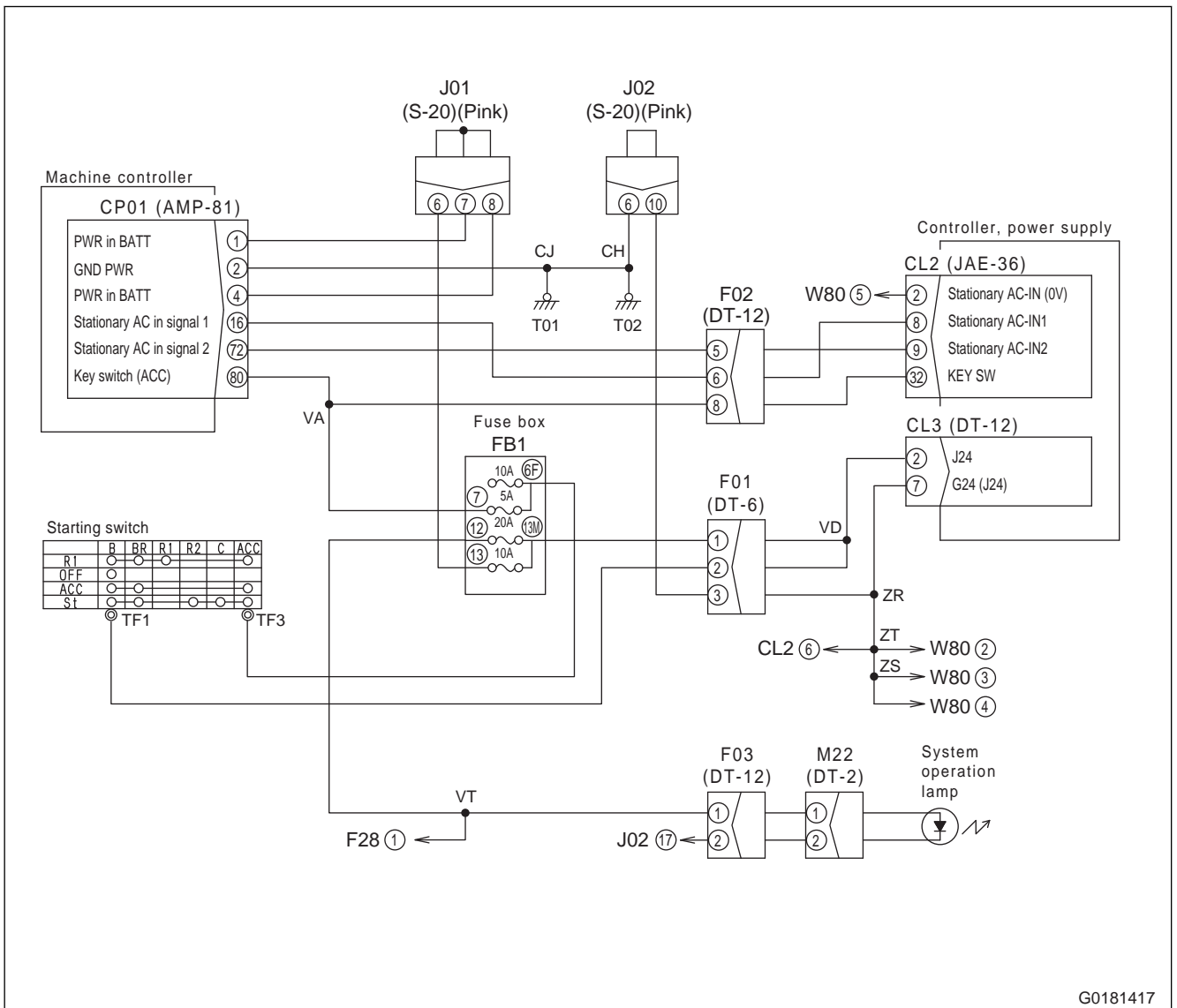

G0181417

Failure Code [GF02NS]

Action level	Failure code	Failure	ABNL HIGH TEMP) BATTERY CELL (BMS system)
L03	GF02NS		
Details of failure	Max Cell Temp $\geq 65^{\circ}\text{C}$ is sensed for 3 seconds.		
Action of controller	<ul style="list-style-type: none"> • During operation, shows a warning on the machine monitor, operates the alarm buzzer, and stops the machine. • During charge, stops the charge. 		
Phenomenon on machine	<ul style="list-style-type: none"> • The electric motor cannot start. • Charge is not possible. 		
Related information	<ul style="list-style-type: none"> • "Max Cell Temp" can be examined with the monitoring function. (Code: 64501 ($^{\circ}\text{C}$)) • After the repair is done, make sure that the failure code is not shown with the operation that follows. Procedure: Turn on the special power supply for battery. Turn the starting switch to the ON position. 		

No.	Cause	Procedure, measuring location, criteria, and remarks
1	Environmental temperature is high.	If the machine is used in an environment of 45°C or more, make the operating environment better.
2	Continuous operation	If the machine is operated and charged continuously without interruption, give a period to lower the temperature of the battery.
3	Defective battery (deterioration)	The battery pack is defective. (Because this is an internal defect, the troubleshooting cannot be done.)

Circuit Diagram of Inverter FET

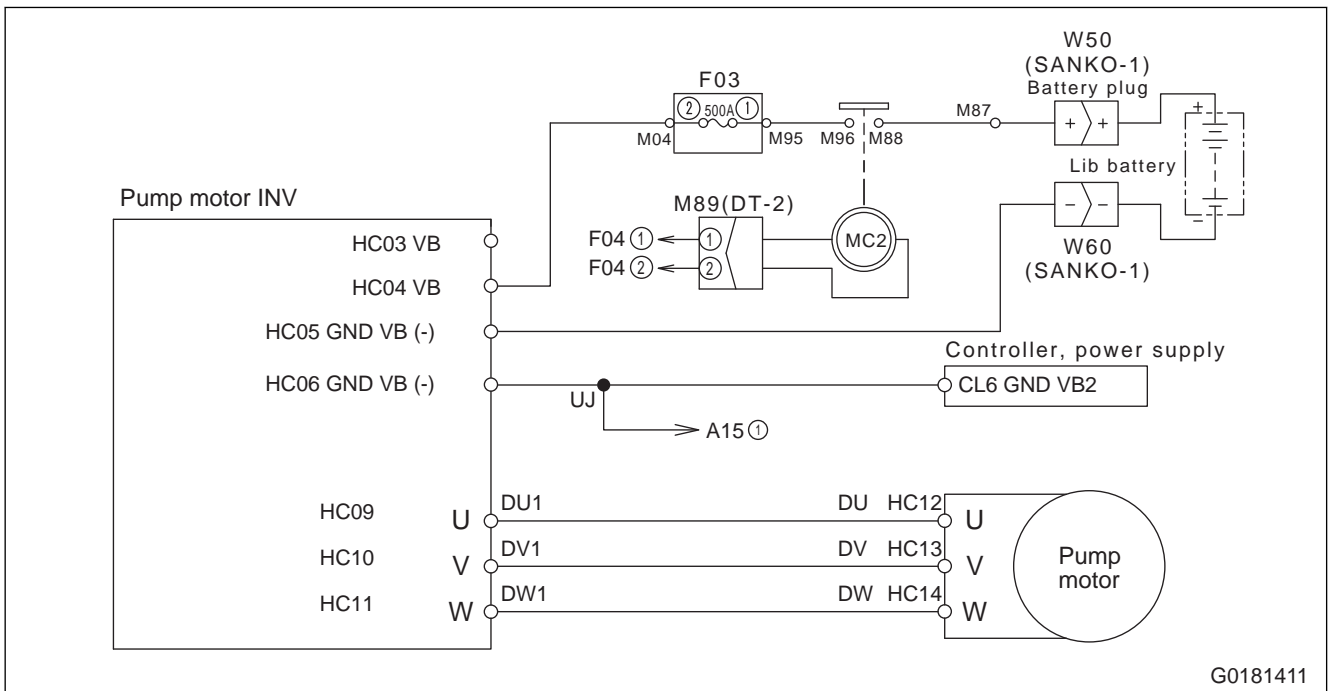

Circuit Diagram of Inverter Quick Charge

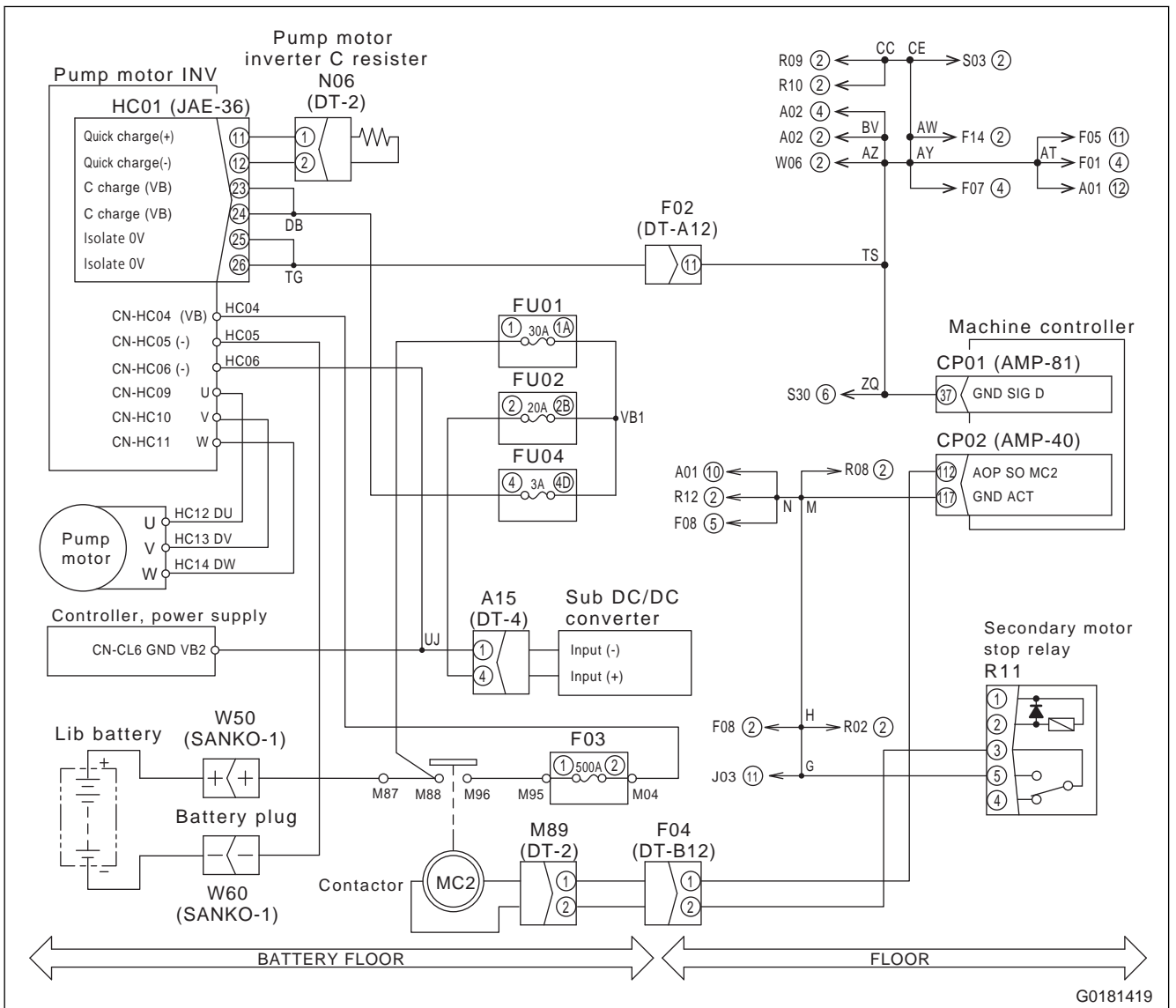

Failure Code [GF1MKB]

Action level	Failure code	Failure	SHORT) Upper FET(INV) (Inverter system)
L04	GF1MKB		
Details of failure	The FET in the inverter is broken and has a short circuit, and a voltage of 80% or more of the P3 (inverter main circuit capacitor) voltage is sensed continuously for 50msec at the electric motor terminals.		
Action of controller	<ul style="list-style-type: none"> Does not turn on the main contactor (MC2). Turns off the output to the inverter. If the starting switch is turned to the OFF position one time after the cause of the failure is removed, the machine will go back to the correct state. 		
Phenomenon on machine	Travel, swing, and work equipment cannot be operated.		
Related information	After the repair is done, make sure that the failure code is not shown with the operation that follows. Procedure: Turn on the special power supply for battery. Turn the starting switch to the ON position.		

No.	Cause	Procedure, measuring location, criteria, and remarks	
1	Short circuit in motor cable	1. Turn the starting switch to the OFF position.	
		2. Make sure that the system operating lamp does not come on. Turn the special power supply for battery to the OFF position. (Wait for 10 minutes or more.)	
		3. Visually examine the terminals DU1, DV1, and DW1 of the motor cable, and terminal HC04 (VB) for foreign material.	
		4. Disconnect each terminal of DU1, DV1, DW1, and HC04 to do the troubleshooting.	
	Resistance	Between DU1 (cable side) and HC04 (cable side)	Min. 1MΩ
		Between DV1 (cable side) and HC04 (cable side)	Min. 1MΩ
		Between DW1 (cable side) and HC04 (cable side)	Min. 1MΩ

Failure Code [GF33MA]

Action level	Failure code	Failure	ABNL) Rotation SNSR(ELE-MOT) (Inverter system)
L04	GF33MA		
Details of failure	<ul style="list-style-type: none"> The variation in the speed of the electric motor is abnormal. An open circuit in the electric motor speed sensor is sensed. 		
Action of controller	<ul style="list-style-type: none"> Turns off the output to the inverter. If the starting switch is turned to the OFF position one time after the cause of the failure is removed, the machine will go back to the correct state. 		
Phenomenon on machine	The machine does not operate.		
Related information	After the repair is done, make sure that the failure code is not shown with the operation that follows. Procedure: Turn on the special power supply for battery. Turn the starting switch to the ON position.		

No.	Cause	Procedure, measuring location, criteria, and remarks		
1	Open circuit in wiring harness of electric motor speed sensor (resolver)	1. Turn the starting switch to the OFF position. 2. Make sure that the system operating lamp does not come on. Turn the special power supply for battery to the OFF position. (Wait for 10 minutes or more.) 3. Disconnect the connectors HC02 and P22. Connect a T-adapter to the female side of P22 to do the troubleshooting.		
		Resistance	Between HC02 (female) (3) and P22 (female) (3)	Max. 1Ω
			Between HC02 (female) (4) and P22 (female) (4)	Max. 1Ω
			Between HC02 (female) (5) and P22 (female) (5)	Max. 1Ω
			Between HC02 (female) (28) and P22 (female) (6)	Max. 1Ω
			Between HC02 (female) (27) and P22 (female) (1)	Max. 1Ω
			Between HC02 (female) (29) and P22 (female) (2)	Max. 1Ω
2	Short circuit in electric motor speed sensor (resolver)	1. Turn the starting switch to the OFF position. 2. Make sure that the system operating lamp does not come on. Turn the special power supply for battery to the OFF position. (Wait for 10 minutes or more.) 3. Disconnect the connectors HC02 and P22 to do the troubleshooting.		
		Resistance	Between HC02 (female) (3) and (16)	Min. 1MΩ
			Between HC02 (female) (4) and (16)	Min. 1MΩ
			Between HC02 (female) (5) and (16)	Min. 1MΩ
			Between HC02 (female) (27) and (16)	Min. 1MΩ
			Between HC02 (female) (28) and (16)	Min. 1MΩ
			Between HC02 (female) (29) and (16)	Min. 1MΩ

Failure Code [GFAHKL]

Action level	Failure code	Failure	ABNL) FET LOW VOL. (CHGR1) (Machine controller system)
L03	GFAHKL		
Details of failure	The input voltage of the stationary battery charger is low.		
Action of controller	<ul style="list-style-type: none"> • Stops the charge. • Shows a warning on the machine monitor and operates the alarm buzzer. 		
Phenomenon on machine	Charge is not possible.		
Related information	Liquid crystal panel display of stationary battery charger: FET Undervoltage		

No.	Cause	Procedure, measuring location, criteria, and remarks		
1	Abnormal AC power supply voltage	1. Disconnect the charge plug. Turn off the power supply breaker on the building side. 2. Make sure that there is no obstacle in other load equipment. 3. Turn the power supply breaker on the building side to ON. 4. Measure the voltage of the AC power supply to do the troubleshooting. ⚠ Be careful not to get an electric shock when you measure AC voltage.		
		Voltage	Between U and V of power supply breaker on the building side	AC 360 to 440V
			Between V and W of power supply breaker on the building side	AC 360 to 440V
			Between W and U of power supply breaker on the building side	AC 360 to 440V
2	Defective control circuit board	If no failure is found by above checks, the control circuit board is defective. (Because this is an internal defect, troubleshooting cannot be done.)		
3	Defective stationary battery charger	If no failure is found by above checks, the stationary battery charger is defective. (Because this is an internal defect, troubleshooting cannot be done.)		

Charge Plug (Machine Side)

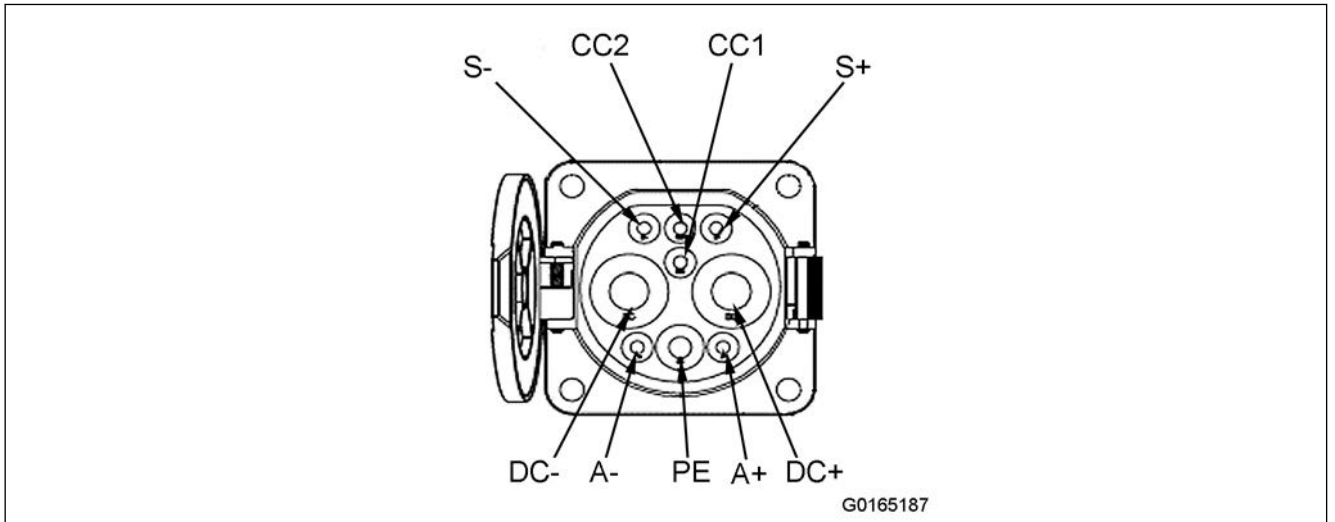

Charge Plug (Stationary Charger Side)

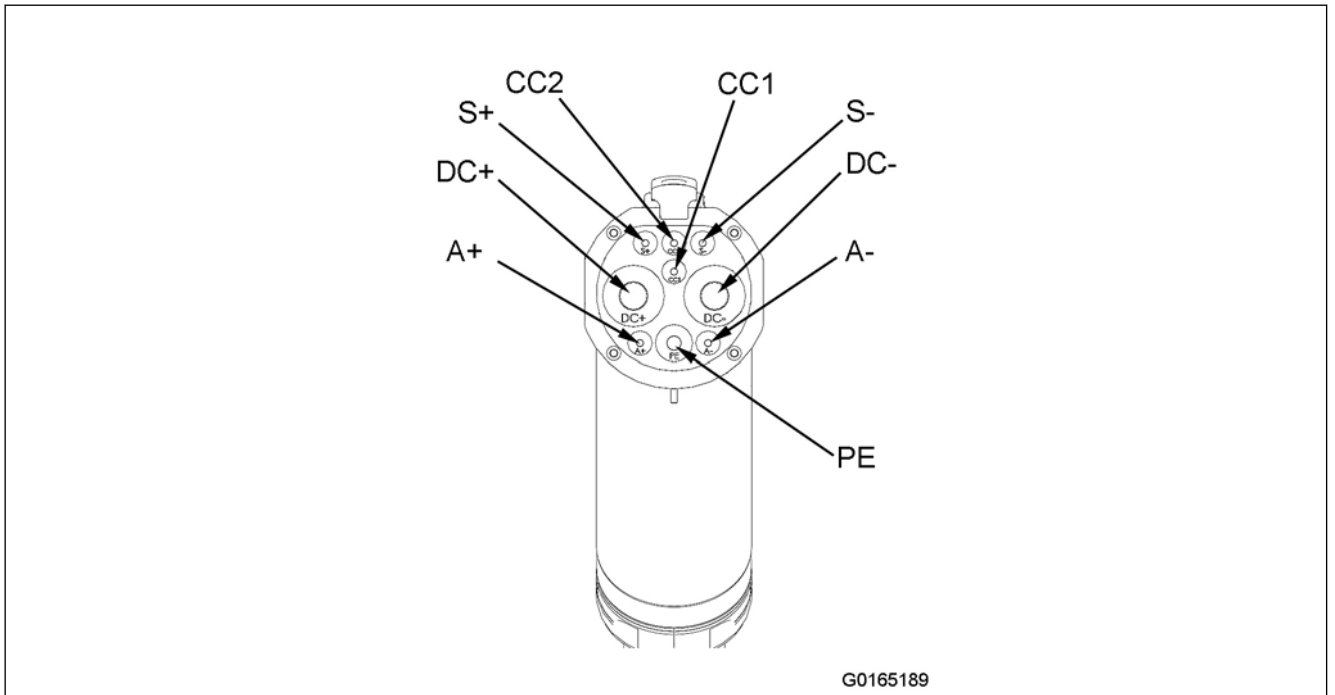

Circuit Diagram of ABNL) CAN COMM. (for CHGR)

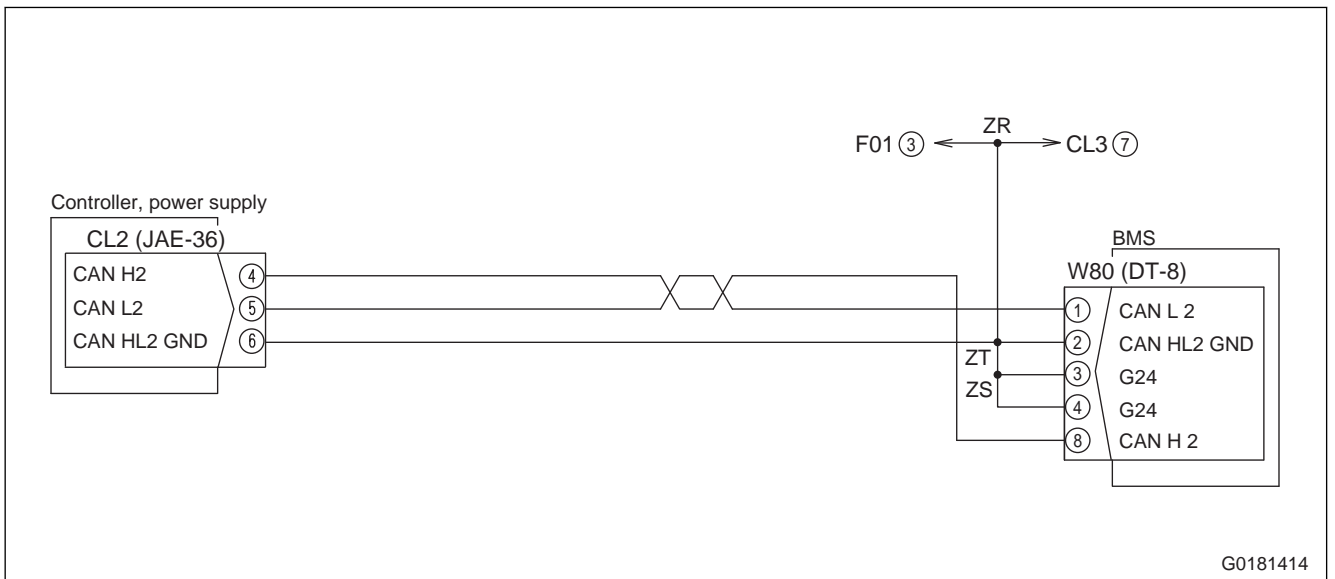

Circuit Diagram of Continuous Electric 24V System

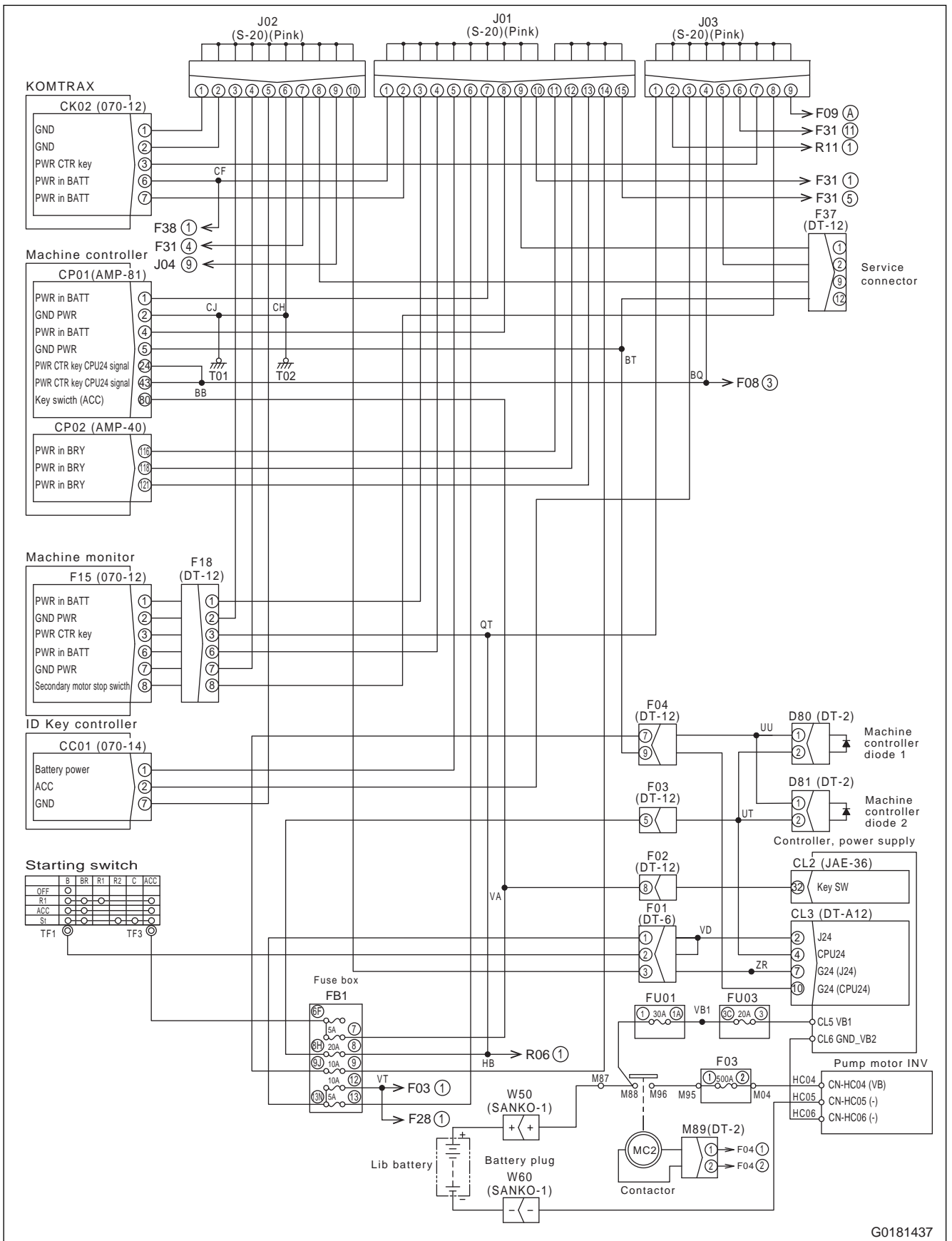

G0181437

Failure Code [GFDKKY]

Action level	Failure code	Failure	SHORT_P) K20 (Power supply controller system)
L04	GFDKKY		
Details of failure	When the K20 start signal is OFF, K20 detection voltage $\geq 5V$ is sensed continuously for 40sec.		
Action of controller	<ul style="list-style-type: none"> Stops the power supply output to K20. After the cause of the failure is removed, it recovers when the starting switch is turned to the OFF position one time or the system is put in the charge mode. 		
Phenomenon on machine	The component (inverter) that uses K20 cannot operate.		
Related information	After the repair is done, make sure that the failure code is not shown with the operation that follows. Procedure: Turn on the special power supply for battery. Turn the starting switch to the ON position.		

No.	Cause	Procedure, measuring location, criteria, and remarks		
1	Hot short circuit in wiring harness	1. Turn the starting switch to the OFF position.		
		2. Make sure that the system operating lamp does not come on. Turn the special power supply for battery to the OFF position. (Wait for 10 minutes or more.)		
		3. Disconnect the connector CL1.		
		4. Turn on the special power supply for battery.		
		5. Turn the starting switch to the ON position to do the troubleshooting.		
		Voltage	Between CL1 (female) (1) and CL6	Max. 1V
			Between CL1 (female) (2) and CL6	Max. 1V
2	Defective power supply controller	If no failure is found by above checks, the power supply controller is defective. (Because this is an internal defect, the troubleshooting cannot be done.)		

Circuit Diagram of Key 20V System

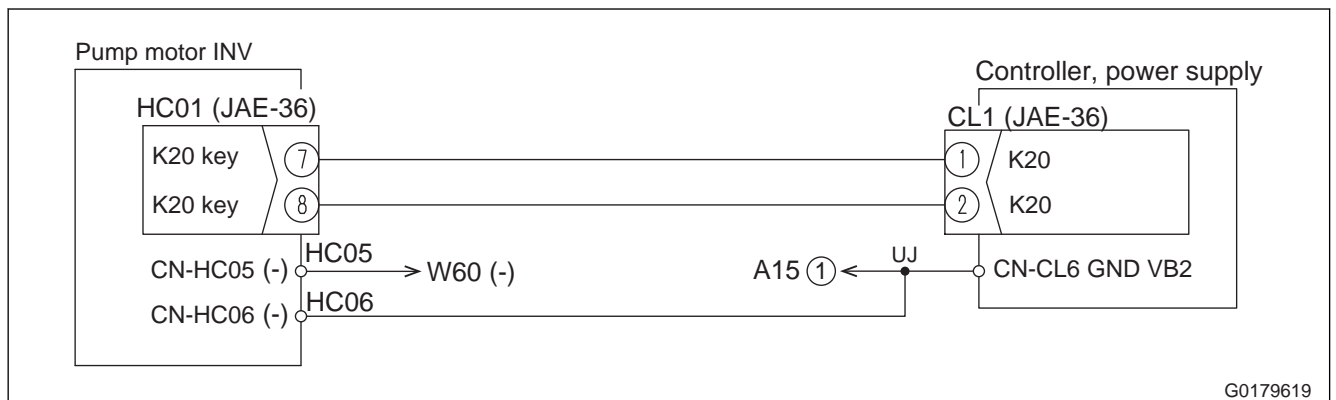

Failure Code [GFDVN8]

Action level	Failure code	Failure	HIGH2) TEMP (P-CON) (Power supply controller system)
L04	GFDVN8		
Details of failure	Power supply controller internal temperature $\geq 110^{\circ}\text{C}$ is sensed continuously for 500msec.		
Action of controller	<ul style="list-style-type: none"> • Stops the output to all power supplies. • When the internal temperature drops to 110°C or less, it recovers automatically. 		
Phenomenon on machine	The machine cannot operate.		
Related information	None		
No.	Cause	Procedure, measuring location, criteria, and remarks	
1	Overloaded power supply controller	Stop the machine and cool the temperature of the power supply controller.	
2	Defective temperature sensor of power supply controller	If this occurs frequently during usual operation, the power supply controller is defective. (Because this is an internal defect, the troubleshooting cannot be done.)	

Circuit Diagram of PPC Lock Switch

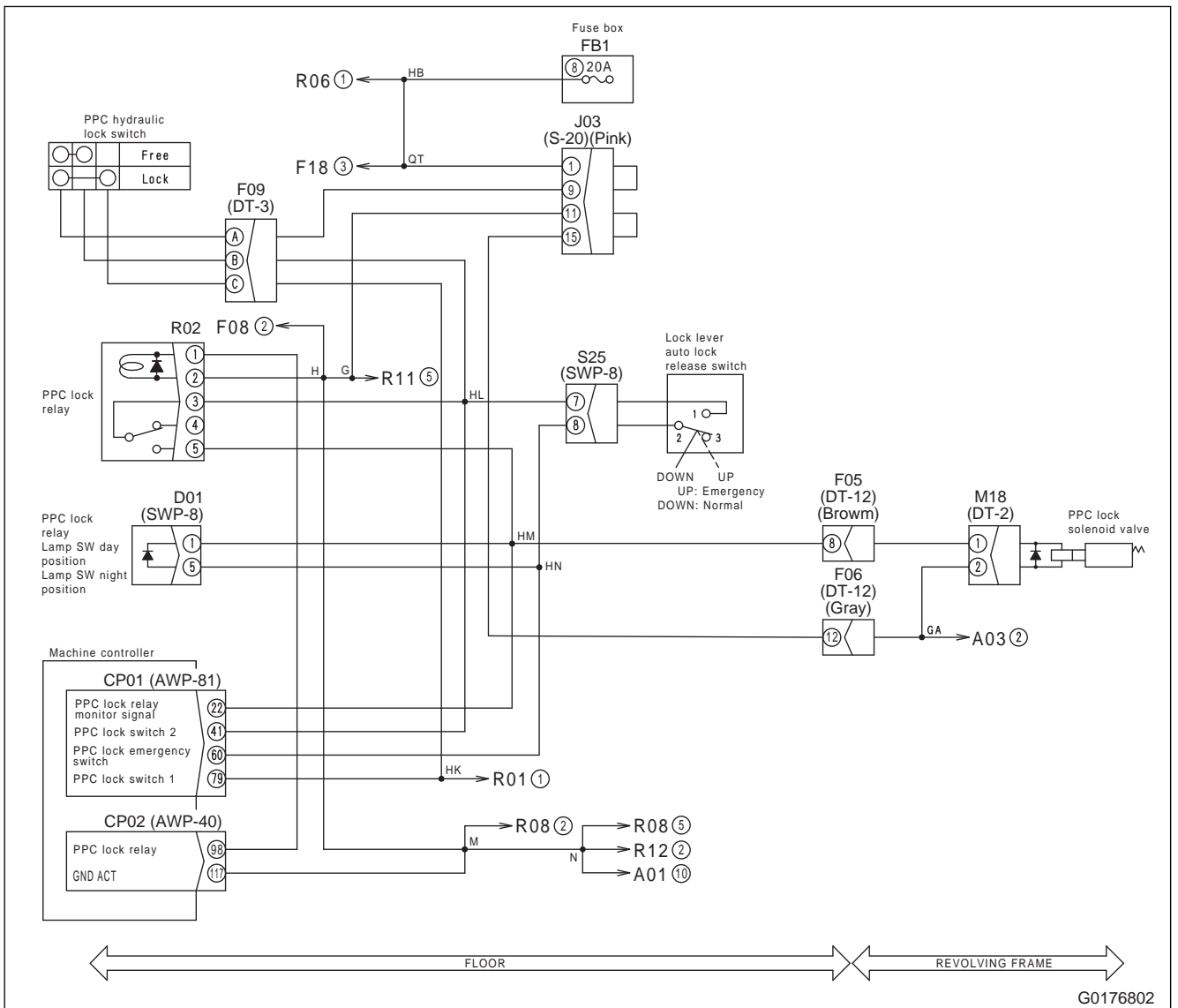

E-10 Some Areas of Machine Monitor Screen are Not Shown

Failure phenomenon	Some areas of the machine monitor screen are not shown.	
Related information	None	
No.	Cause	Procedure, measuring location, criteria, and remarks
1	Defective machine monitor (Liquid crystal panel part)	Turn the starting switch to the ON position to do the troubleshooting.
		Function switch operation: Hold down [F8] and push [F6], then release only [F6]. If the liquid crystal panel comes on (fully white), it is correct.
2	Defective machine monitor	If no failure is found by above checks, the machine monitor is defective. (Because this is an internal defect, troubleshooting cannot be done.)

Circuit Diagram of Horn

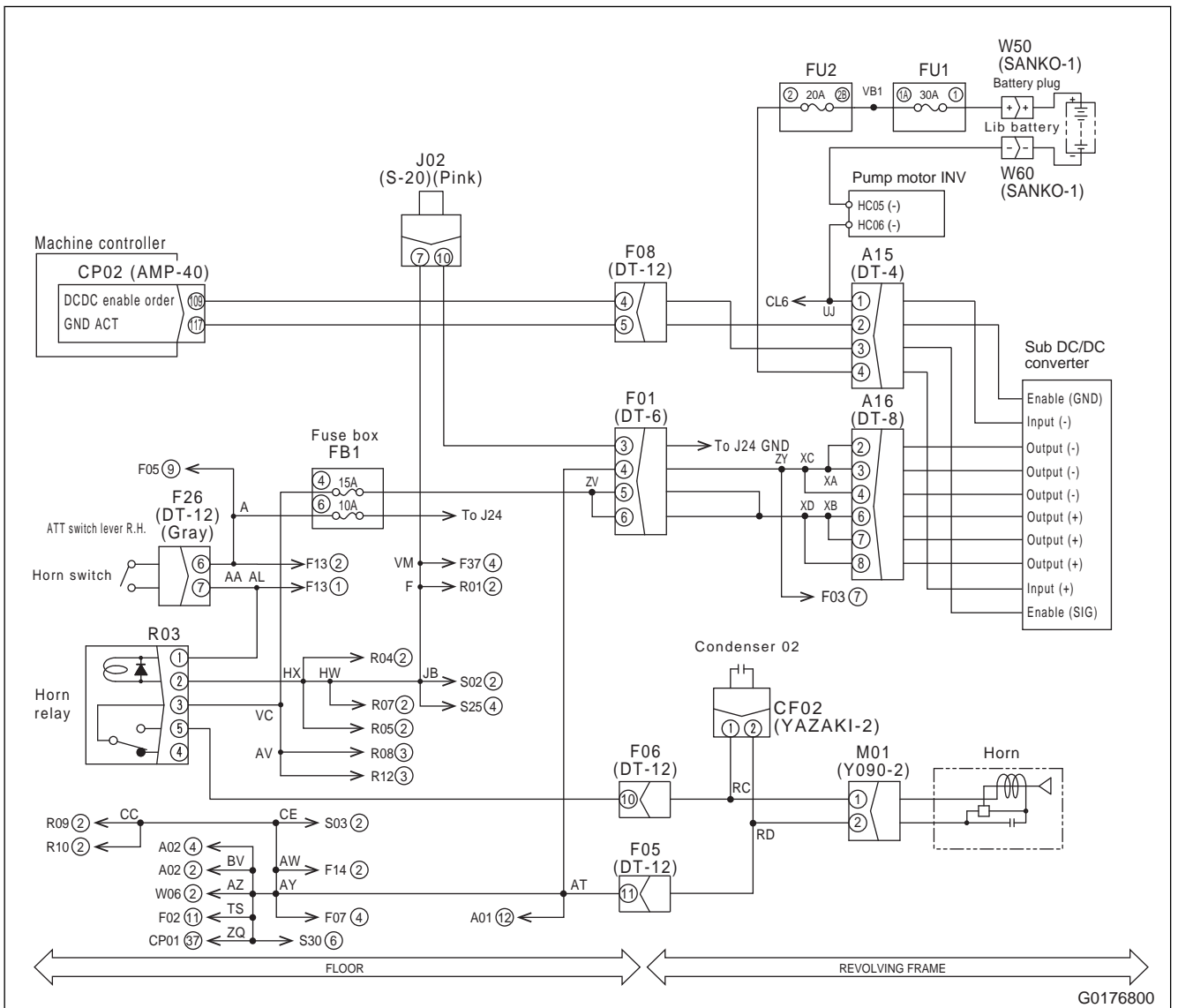

H-2 All Work Equipment or Travel Does Not Operate

Failure phenomenon	All work equipment or travel do not operate.
Related information	<ul style="list-style-type: none"> Do the troubleshooting after the working mode is set to Power mode (P). Make sure that the oil level in the hydraulic tank is correct. Set the hydraulic oil temperature to 45 to 55°C. Make sure that the swing and blade operations are correct.

No.	Cause	Procedure, measuring location, criteria, and remarks	
1	Defective adjustment or malfunction of main relief valve	1. Stop the electric motor for the preparation. 2. Start the electric motor, and run it at high idle to do the troubleshooting.	
		Main relief pressure	<ul style="list-style-type: none"> Arm IN relief Travel relief 26.0(+0.98/-1.47)MPa {265(+10/-15)kgf/cm ² }
		If the oil pressure does not become correct even after adjustment, there can be a malfunction or an internal defect of the main relief valve. Examine it.	

H-15 All Work Equipment Do Not Operate

Failure phenomenon	All work equipment do not operate.		
Related information	<ul style="list-style-type: none"> Do the troubleshooting after the working mode is set to Power mode (P). Make sure that the oil level in the hydraulic tank is correct. Set the hydraulic oil temperature to 45 to 55°C. Make sure that the travel, swing, and blade operations are correct. 		
No.	Cause	Procedure, measuring location, criteria, and remarks	
1	Defective seal of logic valve or pilot pressure check valve	<ol style="list-style-type: none"> Stop the electric motor for the preparation. Start the electric motor, and run it at high idle to do the troubleshooting. 	
		PPC valve outlet pressure	<ul style="list-style-type: none"> Right and left work equipment control levers: Neutral Boom swing control pedal: Neutral <p>0MPa {0kgf/cm²}</p> <ul style="list-style-type: none"> Right and left work equipment control levers: Two directions Boom swing control pedal: swing RIGHT <p>2.94(+0.49/-0.1)MPa {30(+5/-1)kgf/cm²}</p>

H-26 Hydraulic Drift of Blade is Large

Failure phenomenon	Hydraulic drift of the blade is large. (When the blade is raised or the blade pushes the ground)
Related information	<ul style="list-style-type: none"> Do the troubleshooting after the working mode is set to Power mode (P). Set the hydraulic oil temperature to 45 to 55°C.

No.	Cause	Procedure, measuring location, criteria, and remarks		
1	Defective blade cylinder	1. Stop the electric motor for the preparation. 2. Start the electric motor, and run it at high idle to do the troubleshooting.		
		Oil leakage from blade cylinder	Blade LOWER relief	Max. 10mℓ/min
2	Malfunction of blade RAISE (suction safety valve)	1. Stop the electric motor for the preparation. 2. Start the electric motor, and run it at high idle to do the troubleshooting.		
		Blade relief pressure	Blade RAISE relief	21.6(±0.98)MPa {220(±10)kgf/cm ² }
		If only the blade RAISE relief pressure is low, there can be an abnormality of the suction safety valve. Examine it. Make sure that the check valve of the suction safety valve sticks to the seat of the body (not stuck in the middle). REMARK The relief pressure of the suction safety valve cannot be adjusted while it is installed on the machine. If a failure is found, replace the safety valve assembly.		
3	Malfunction of blade valve (spool)	1. Release the remained pressure from the hydraulic tank and piping. 2. Stop the electric motor to do the troubleshooting.		
		<ul style="list-style-type: none"> Examine the control valve body and blade spool to see if they are not twisted or stuck. (They must move smoothly and not be stuck.) Remove the blade spool from the body, and examine it for damage and dirt. Be careful that dirt or other foreign materials do not enter when you restore it.		
4	Malfunction of blade LOWER (suction valve)	1. Stop the electric motor for the preparation. 2. Start the electric motor, and run it at high idle to do the troubleshooting.		
		Blade relief pressure	Blade LOWER relief	21.6(±0.98)MPa {220(±10)kgf/cm ² }
		If only the blade LOWER relief pressure is low of the swing and blade LOWER relief pressure, the suction valve can be abnormal. Examine it. <ul style="list-style-type: none"> Make sure that the check valve of the suction valve sticks to the seat of the body (not stuck in the middle). Remove the check valve from the body, and examine it for damage and dirt. Examine the spring for looseness or deformation. Be careful that dirt or other foreign materials do not enter when you restore it.		

H-35 Travel Speed Does Not Change, or Travel Speed is Too Slow or Fast

Failure phenomenon	Travel speed does not change, or travel speed is too slow or fast.
Related information	<ul style="list-style-type: none"> Do the troubleshooting after the working mode is set to Power mode (P). Make sure that the oil level in the hydraulic tank is correct. Set the hydraulic oil temperature to 45 to 55°C. If “Failure Code [DW43KA]”, “Failure Code [DW43KB]”, or “Failure Code [DW43KY]” is shown, do the troubleshooting for the failure code first. The ON/OFF state of the 2nd travel selector solenoid valve can be examined with the monitoring function. (Code: 02300)

No.	Cause	Procedure, measuring location, criteria, and remarks			
1	Malfunction of travel speed solenoid valve	1. Stop the electric motor for the preparation. 2. Start the electric motor, and run it at high idle to do the troubleshooting.			
		Solenoid valve outlet pressure	Travel speed: Lo	Travel lever: Neutral	0MPa {0kgf/cm ² }
			Travel speed: Hi	Travel lever: Fine operation	3.2(+0.2/0)MPa {32.6(+2/0)kgf/cm ² }
2	Defective travel motor (speed selector part)	If no failure is found by the above checks, there can be a malfunction of the speed selector part of the travel motor.			

50 Disassembly and Assembly

Symbol	Part name	Part No.	Specifications	Q'ty	Remarks
C	Socket (Width across flats: 41mm)	Commercially available		1	Removal and installation of nut
	Socket (Width across flats: 46mm)	Commercially available		1	
	Socket (Width across flats: 50mm)	790-302-1270		1	
	Socket (Width across flats: 50mm, long type)	790-302-1490		1	
	Socket (Width across flats: 55mm)	790-302-1280		1	
	Socket (Width across flats: 55mm, long type)	790-302-1470		1	
D	Push tool kit	790-201-1702		1	Press-fit of bushing
	• Grip	790-101-5021		1	
	• Bolt	01010-50816		1	
	• Push tool	790-201-1731		1	
	• Push tool	790-201-1741		1	
	• Push tool	790-201-1751		1	
	• Push tool	790-201-1761		1	
E	Push tool kit	790-201-1500		1	Press-fit of dust seal
	• Grip	790-101-5021		1	
	• Bolt	01010-50816		1	
	• Plate	790-201-1540		1	
	• Plate	790-201-1550		1	
	• Plate	790-201-1560		1	
	• Plate	790-201-1570		1	
F	Ring	796-720-1640		1	Installation of piston ring
	Clamp	07281-00909		1	
	Ring	796-720-1740		1	
	Clamp	07281-00809		1	
	Ring	796-720-1650		1	
	Clamp	07281-01029		1	
G	Expander	790-720-1000		1	

How to Install Swing Motor and Swing Machinery Assembly

Swing motor and swing machinery assembly

1. Lift the swing motor and swing machinery assembly (7), and set it to the installation position.



Swing motor and swing machinery assembly (7):
40kg

2. Install the swing motor and swing machinery assembly (7) with the bolts (6) (6 pieces).



Bolt (6): Liquid adhesive (LT-2)

3. Connect the hoses (1), (2), (3), (4), and (5).

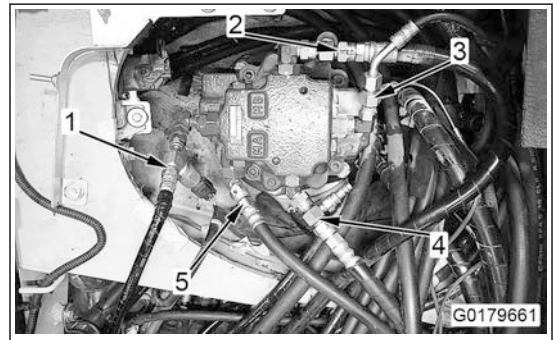
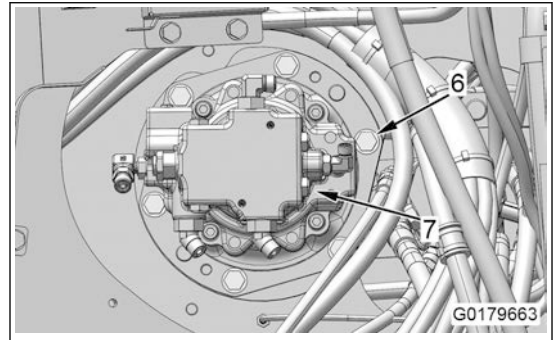

Floor frame assembly

4. Install the floor frame assembly. For details, see "Remove and Install Floor Frame Assembly".

How to Install Track Assembly

1. Lift the track assembly (4), and set it to the installation position.



Rubber shoe: 130kg

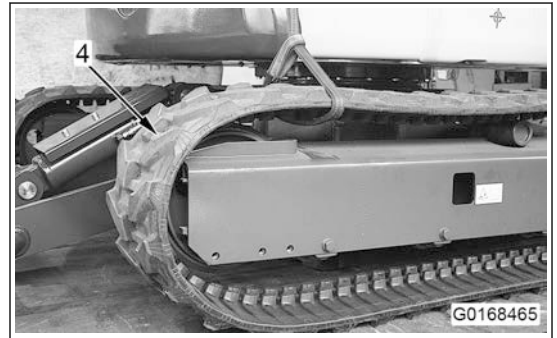

2. Install the cover (3) with the bolts (2) (3 pieces).

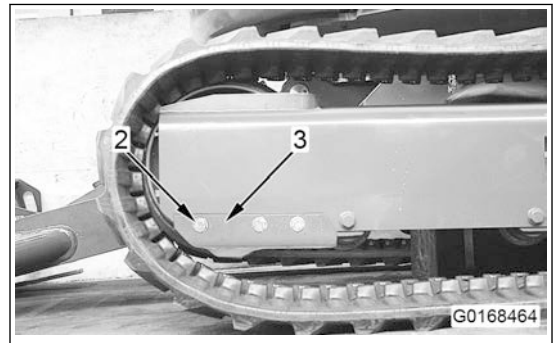

3. Tighten the valve (1), apply grease, and then adjust the track tension.

REMARK

Adjust the track tension. For details, see Testing and Adjusting, "Examine and Adjust Track Tension".

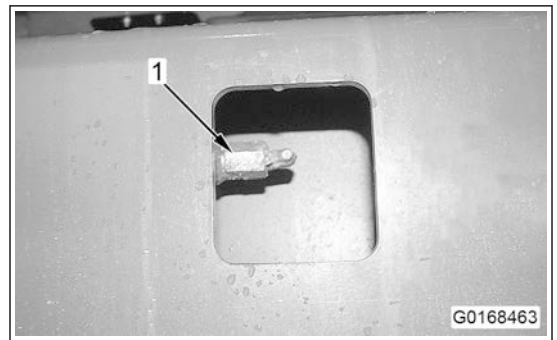

Protector

6. Install the protector. For details, see "Remove and Install Protector".

Hydraulic oil cooler assembly

7. Install the hydraulic oil cooler assembly. For details, see "Remove and Install Hydraulic Oil Cooler Assembly".

Battery assembly

8. Install the battery assembly. For details, see "Remove and Install Battery Assembly".

Floor frame assembly

9. Install the floor frame assembly. For details, see "Remove and Install Floor Frame Assembly".

Work equipment assembly

10. Install the work equipment assembly. For details, see "Remove and Install Work Equipment Assembly".

Remove and Install Hydraulic Tank Assembly

- ⚠ Stop the machine on a level ground, and lower the work equipment to the ground in a stable position.
- ⚠ Set the lock lever to the LOCK position.
- ⚠ Turn the starting switch to the OFF position to stop the electric motor.
- ⚠ Make sure that the system operating lamp is off, push and hold the button of the special power supply for battery for 5 seconds or more to turn off the special power supply for battery. (For details, see Testing and Adjusting, “Handle Special Power Supply for Battery”.)

How to Remove Hydraulic Tank Assembly

Drain hydraulic oil

1. Drain hydraulic oil. For details, see “Drain and Add Hydraulic Oil”.

Open and close floor

2. Open the floor. For details, see Testing and Adjusting, “How to Open and Close Floor”.

Cover

3. Open the maintenance cover (1), and fix it with the rod (2).
4. Remove the pin (3) and washer (4).
5. Disconnect the rod (2) from the maintenance cover (1).

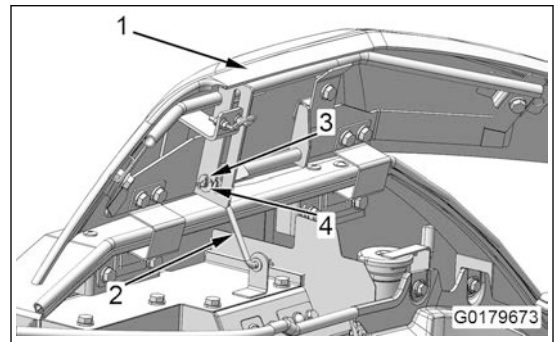

6. Remove the bolts (5) (4 pieces), and remove the maintenance cover (1).

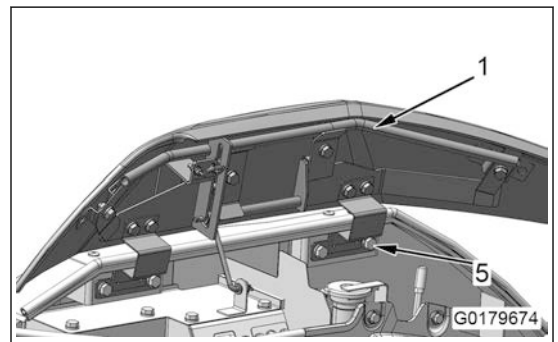

How to Install Blade Assembly

Blade assembly

1. Lift the blade assembly (4), and set it to the installation position.



Blade assembly (4): 190 kg

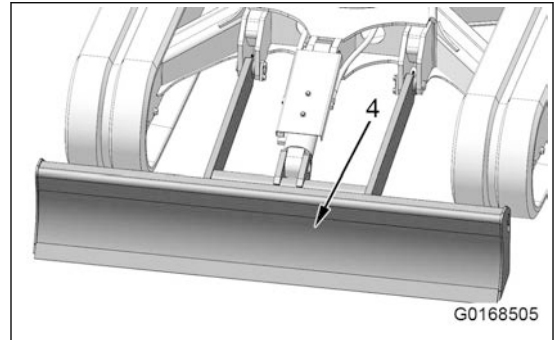

2. Install the pin (6) of the blade and frame with the right and left lock plates (5).



Pin (6): Grease (G2-T)

⚠ Do not insert your fingers into the pin holes when you align their positions.

REMARK

Adjust shims. For details, see Maintenance Standard, "Maintenance Standard for Work Equipment Linkage".

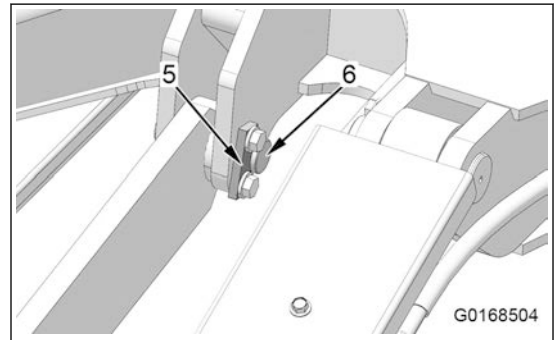

3. Lift the blade cylinder (1), and set it to the installation position.

4. Install the pin (3) with the lock plate (2).



Pin (3): Grease (G2-T)

⚠ Do not insert your fingers into the pin holes when you align their positions.

REMARK

Adjust shims. For details, see Maintenance Standard, "Maintenance Standard for Work Equipment Linkage".

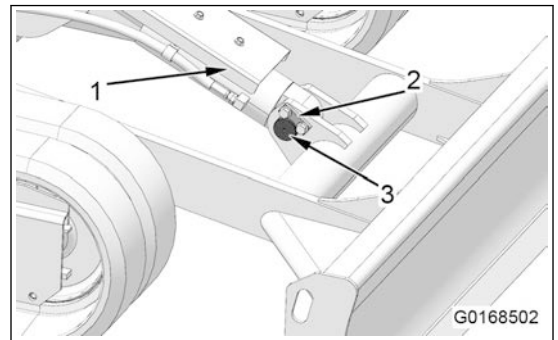

How to Assemble Anti-Drop Valve Assembly

Clean the parts with clean hydraulic oil fully, and replace the O-ring with a new one.

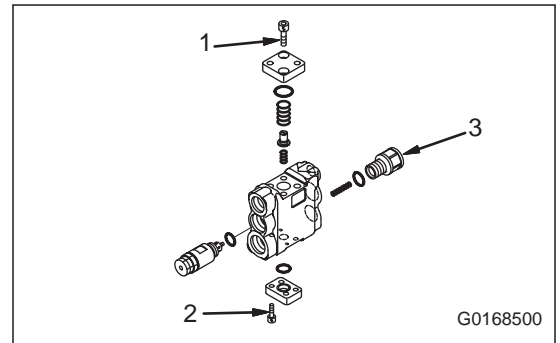

How to Install Floor Frame Assembly

Floor frame assembly

1. Lift the floor frame assembly (49), and set it to the installation position.



Floor frame assembly (49): 250kg

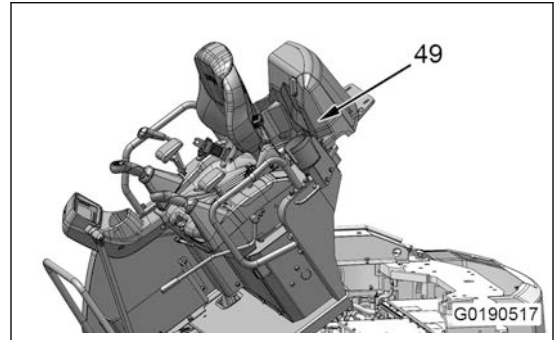

2. Install the pin (60) with the right and left bolts (59) (2 pieces).

⚠ Do not insert your fingers when you align the positions.

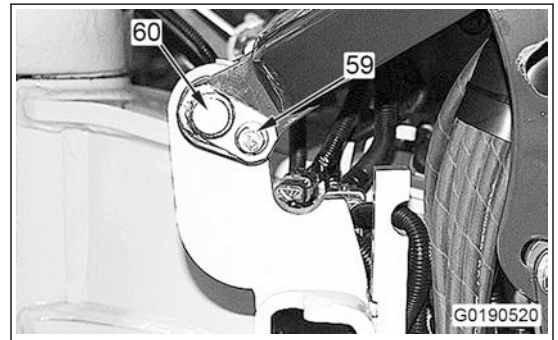

3. Connect the gas spring (58) with the bolts (57) (2 pieces).
4. Connect the wire (56) with the pin (55).
5. Install the collar (54), and install the cotter pin (53).
6. Install the pin (52).
7. Install the collar (51), and install the cotter pin (50).

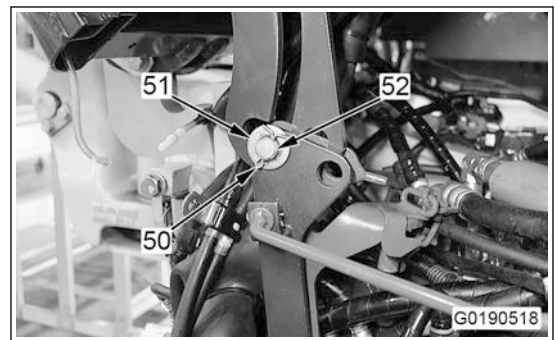
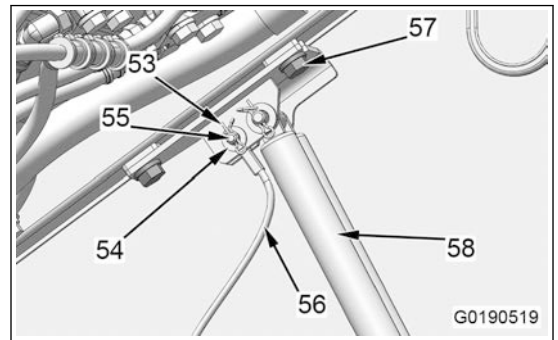

8. Connect the connector A01 (48) on the floor frame.

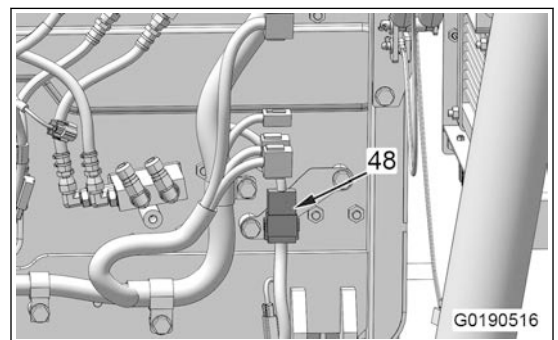

7. Remove the bolts (8) (7 pieces), and remove the cover (9).

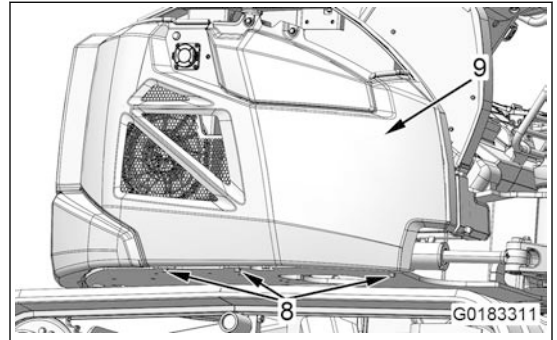
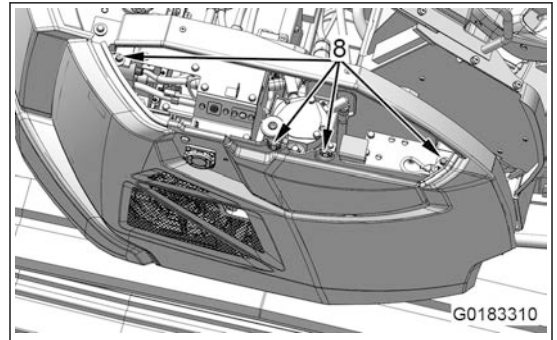

8. Remove the bolts (10) (4 pieces), and remove the cover (11).

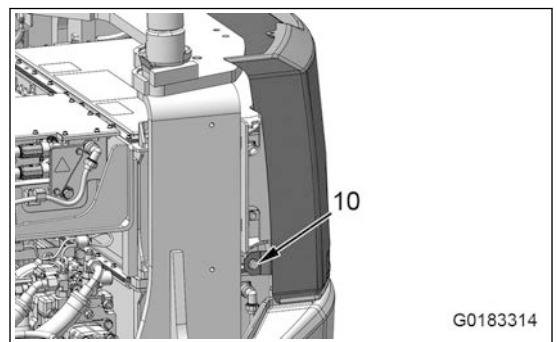
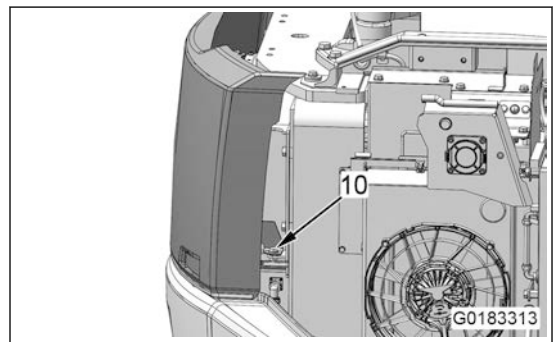
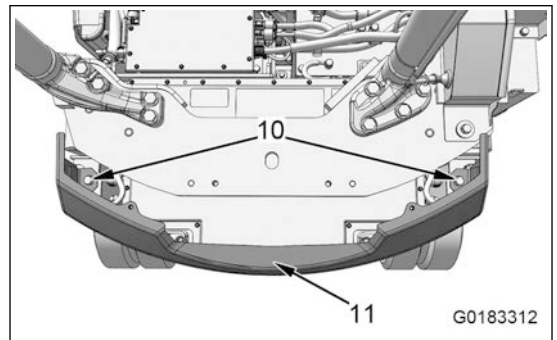

Charge inlet assembly

9. Remove the charge inlet assembly. For details, see “Remove and Install Charge Inlet Assembly”.

How to Install Charge Inlet Assembly

Charge inlet assembly

1. Install the charge inlet assembly (22) with the bolts (21) (3 pieces).
2. Connect the connector M22 (20).

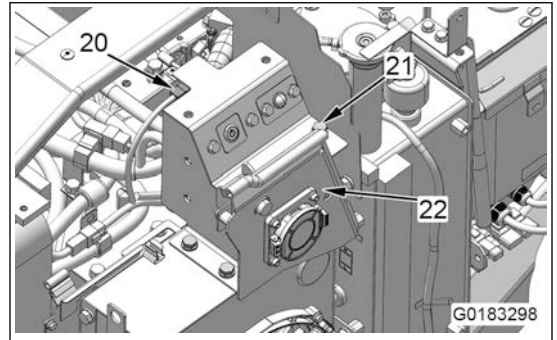

3. Connect the connector A3 (19), and install the clip (18).
4. Install the clamps (17) (2 pieces).

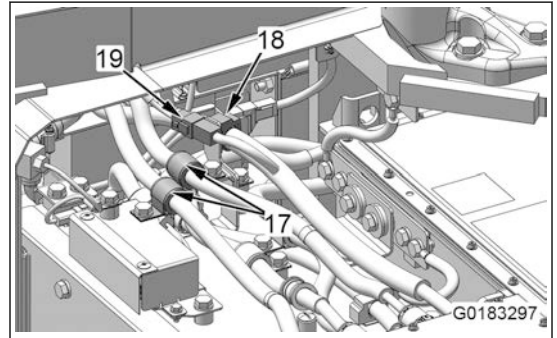

5. Connect the communication connector at receptacle on machine (14), high voltage connector at receptacle on machine (-) (15), and high voltage connector at receptacle on machine (+) (16).

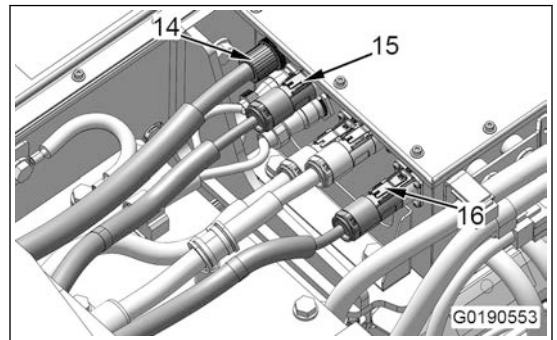

REMARK

- Make sure that the mark (a) of the communication connector at receptacle on machine (14) is set to the upper side of the machine.
- When you connect the high voltage connector at receptacle on machine (-) (15) and high voltage connector at receptacle on machine (+) (16), examine the items that follow.

- 1) Make sure that the O-ring is engaged into the groove correctly.
- 2) After you insert it until click sound comes out, apply force in the direction to pull, and make sure that it is engaged securely.
- 3) Make sure that the lock is applied while it is set horizontally.

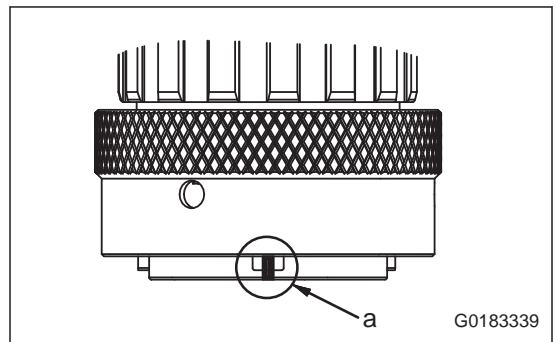

6. Install the band (13).

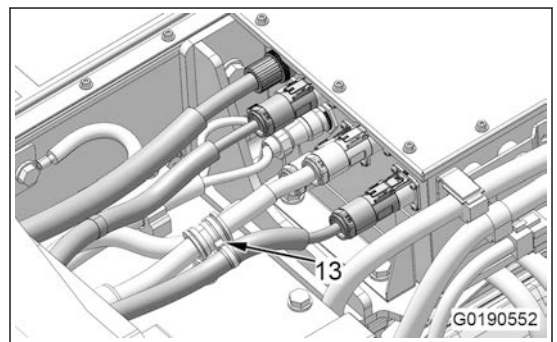

8. Install the cover (27) with the bolts (26) (2 pieces).

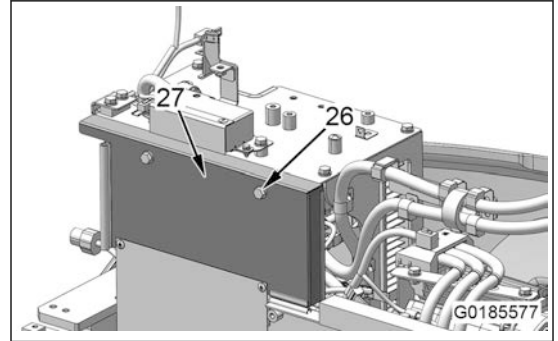

9. Connect the cable (25) with the bolt (24).

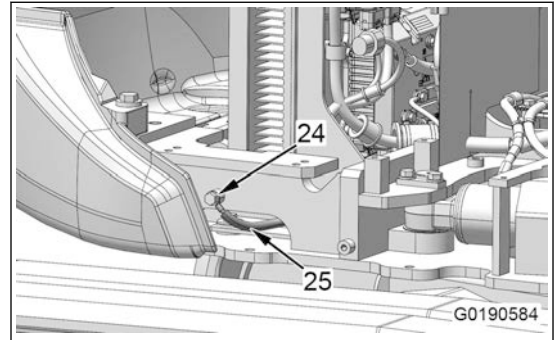

10. Install the clamps (23) (3 pieces).

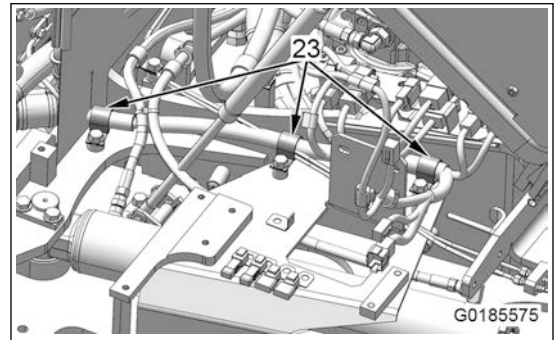

11. Install the relays R80 (21) and R82 (22) with the bolts (20) (2 pieces).

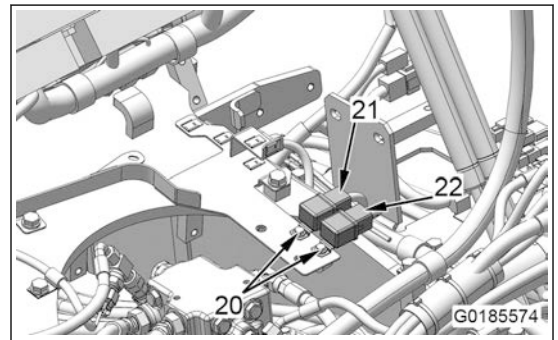

12. Install the cover (19) with the bolts (18) (2 pieces).

13. Install the clip (17).

14. Install the connectors F02 (11), F01 (12), F04 (13), A02 (14), F03 (15), and F08 (16) to the clip, and connect them.

15. Install the bands (10) (2 pieces).

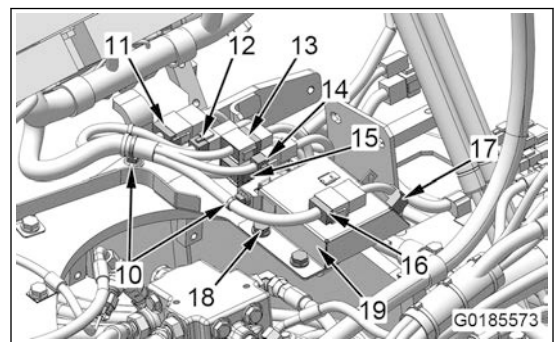

12. Remove the bolts (24) (4 pieces), and remove the DC/DC converter (14).

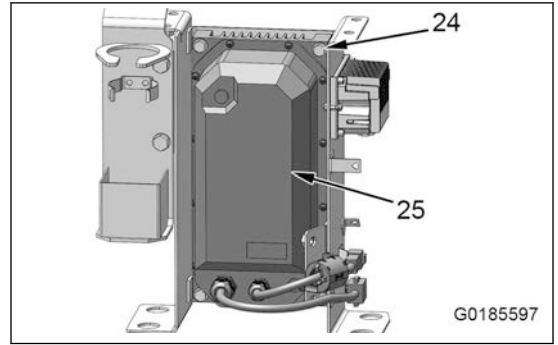

60 Maintenance Standard

Maintenance Standard for Idler

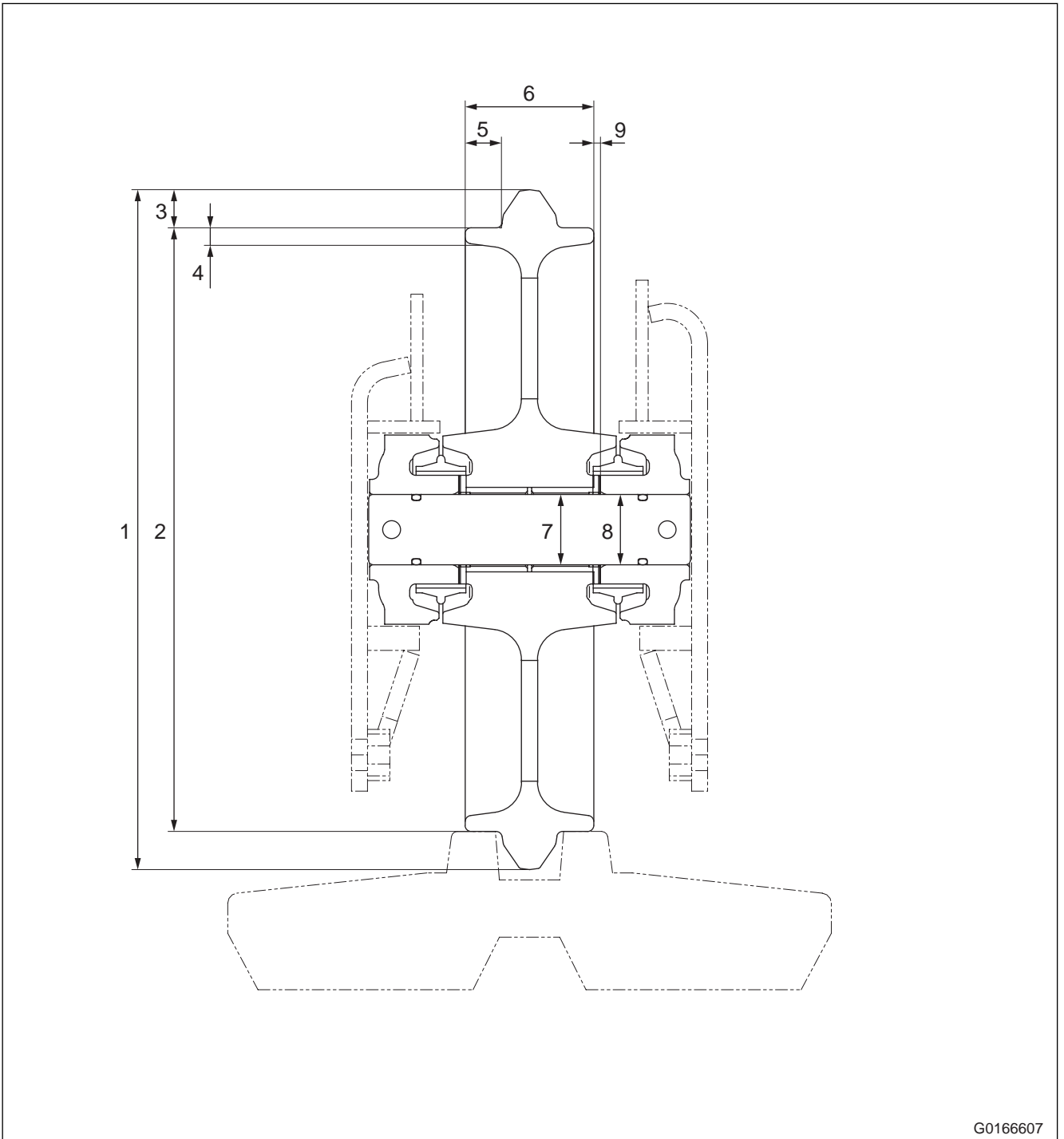

G0166607

No.	Item	Judgment criteria					Remedy
1	Tightening torque of suction safety valve, suction valve, and plug	39.2 to 49Nm {4 to 5kgfm}					Retighten.
2	Tightening torque of main relief valve	49 to 58.8Nm {5 to 6kgfm}					
3	Tightening torque of suction valve plug	6.9 to 9.8Nm {0.7 to 1.0kgfm}					
4	Suction valve spring	Standard dimensions			Repair limit		If it has damage or is deformed, replace the spring.
		Free height × outside diameter	Installed height	Load at installed height	Free height	Load at installed height	
		39.2×4.45mm	33.5mm	5.1N {0.52kgf}	-	4.12N {0.42kgf}	
5	Spool return spring	29×17.5mm	28.5mm	22.6N {2.3kgf}	-	18N {1.84kgf}	
6	Spool return spring	29.2×17.5mm	28.5mm	27.1N {2.76kgf}	-	21.7N {2.21kgf}	

No.	Item	Judgment criteria					Remedy	
		Standard dimensions			Repair limit			
1	Centering spring (for ports P1, P3, and P4)	Free height × outside di- ameter	Installed height	Load at in- stalled height	Free height	Load at in- stalled height	If it has damage or is deformed, replace the spring.	
		43.4× 15.3mm	31.9mm	12.9N {1.31kgf}	-	10.3N {1.05kgf}		
		2	Centering spring (for port P2)	42.5× 15.5mm	31.9mm	22.1N {2.25kgf}		-
3	Metering spring	26.5× 8.15mm	24.9mm	16.7N {1.70kgf}	-	13.3N {1.36kgf}		
4	Tightening torque of nut	69 to 88Nm {7 to 9kgfm}						Retighten.
5	Tightening torque of joint	39 to 49Nm {4 to 5kgfm}						
6	Tightening torque of plug	34.3 to 44.1Nm {3.5 to 4.5kgfm}						
7	Tightening torque of bolt	11.8 to 14.7Nm {1.2 to 1.5kgfm}						

No.	Item	Judgment criteria					Remedy
		Boss width		Hinge width		Standard clearance	
		Standard dimensions	Tolerance	Standard dimensions	Tolerance		
26	Joint part of arm and bucket cylinder	45mm	0mm -0.5mm	46mm	+1.0mm 0mm	1.0 to 2.5mm	Use shims to adjust the clearance to be 0.5mm or less.
		L26: Insert shims with thickness of 1.0mm (2) and 0.5mm (1). R26:-					
27	Joint part of arm and bucket	143.5mm	0mm -0.5mm	145mm	±1mm	0.5 to 3.0mm	-
		L27:- R27:-					
28	Joint part of link and bucket	143.5mm	0mm -0.5mm	145mm	±1mm	0.5 to 3.0mm	-
		L28:- R28:-					
29	Joint part of links	143.5mm	0mm -0.5mm	-	-	-	-
		L29:- R29:-					
30	Joint part of arm and link	143.5mm	0mm -0.5mm	-	-	-	-
		L30:- R30:-					
31	Joint part of track frame and blade	45mm	±0.8mm	48mm	+1.0mm 0mm	2.2 to 4.8mm	Use shims to adjust the clearance to be 1.0mm or less.
		(*1) L31: Insert a shim with thickness of 1.0mm (2). R31:-					
32	Joint part of track frame and blade cylinder	55mm	0mm -0.5mm	58mm	+1.0mm 0mm	3.0 to 4.5mm	Use shims to adjust the clearance to be 1.0mm or less.
		L32:- R32: Insert a shim with thickness of 1.0mm (4).					
33	Joint part of blade and blade cylinder	55mm	0mm -0.5mm	58mm	+1.0mm 0mm	3.0 to 4.5mm	Use shims to adjust the clearance to be 1.0mm or less.
		L33:- R33: Insert a shim with thickness of 1.0mm (4).					

*1: The figure shows the left joint part as an example. The insertion position of shim is different for the right and left parts.

The number in parentheses after each shim thickness is the required number of shims.

Function of Stationary Charger

- The stationary battery charger charges the battery optimally in response to the command from the BMS.
- The stationary battery charger starts charging automatically after the charge plug is connected.
- To stop charging with the stationary battery charger or start charging again while the battery charge is stopped, you can operate the charger with the charge stop switch or charge start switch.

REMARK

- For details of the charge method, see “Operation and Maintenance Manual”.
- For the breaker capacity setting of battery charger, see “Operation and Maintenance Manual”.
- For the battery charger setting and the power supply equipment of battery charger, see “Operation and Maintenance Manual”.

Input and Output Signals of Stationary Charger

Pin name	Signal name
DC(+)	DC power supply (+)
DC(-)	DC power supply (-)
PE	Ground
S(+)	CAN2_H
S(-)	CAN2_L
CC1	Detection of fitting (battery charger side)
CC2	-
A(+)	Detection of fitting (machine side)
A(-)	Detection of fitting (machine side)

Part No.	Part name	Number of pins	ID marking	T-adapter kit						Non-kit part
				799-A65-4600	799-902-9300					
799-601-4620	Adapter for controller (ENG-T4)	4	799-601-4620	•						
799-601-4630	Adapter for controller (ENG-T4)	2	799-601-4630	•						
799-601-4640	Adapter for controller (ENG-T4)	2	799-601-4640	•						
799-601-4651	Adapter for controller (ENG-T4)	24	799-601-4651	•						
799-601-4660	Adapter for controller (ENG-T4)	3	799-601-4660	•						
799-902-9310	Adapter for control box	19	799-902-9310		•					
799-902-9320	Adapter for IMU	10	799-902-9320		•					
799-902-9330	Adapter for MS cylinder	6	799-902-9330		•					
799T-601-4611	KDPF differential pressure sensor short socket adapter	4	799T-601-4611	•						
799T-601-4670	KDPF outlet pressure sensor short socket adapter	4	799T-601-4670	•						
799T-601-4680	KDPF dummy temperature sensor	4	799T-601-4680	•						

Upper Surface of Stationary Battery Charger

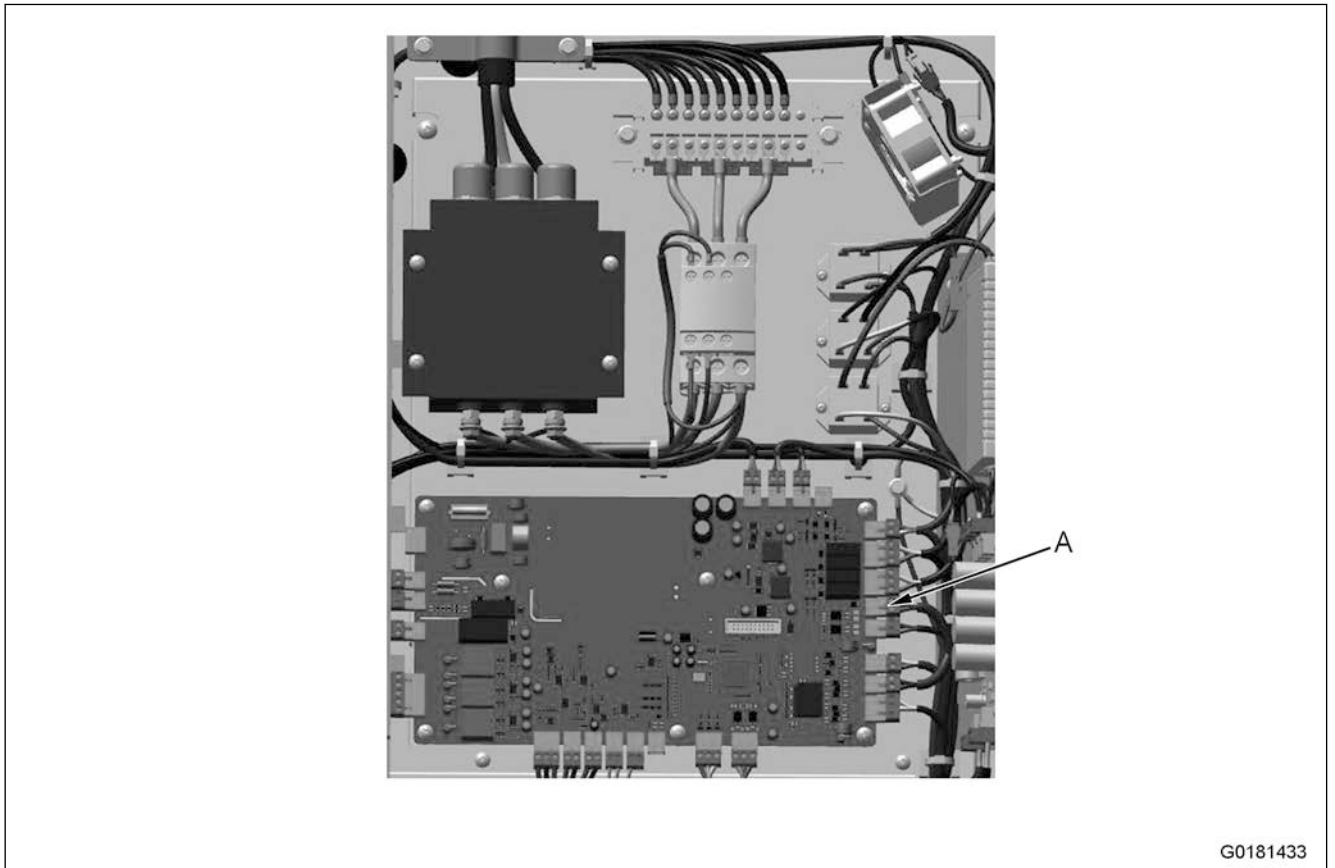

A: SW2 connector

Failure Code [GFAMMR]

Action level	Failure code	Failure	ABNL) PLUG FITTING (CHGR1) (Machine controller system)
L03	GFAMMR		
Details of failure	The charge plug of the stationary battery charger is not fully inserted.		
Action of controller	<ul style="list-style-type: none"> Stops the charge. Shows a warning on the machine monitor and operates the alarm buzzer. 		
Phenomenon on machine	Charge is not possible.		
Related information	Liquid crystal panel display of stationary battery charger: Plug Det Error		

No.	Cause	Procedure, measuring location, criteria, and remarks		
1	Defective charge inlet on machine side	<ol style="list-style-type: none"> Turn the starting switch to the OFF position. Make sure that the system operating lamp does not come on. Turn the special power supply for battery to the OFF position. (Wait for 10 minutes or more.) Disconnect the charge plug. Measure the resistance to sense the connection of the charge plug (machine side) to do the troubleshooting. 		
		Resistance	Between charge plug (machine side) terminal CC1 and terminal PE	Approx. 1kΩ
2	Defective charge cable (detection of engagement)	<ol style="list-style-type: none"> Disconnect the charge plug. Turn off the power supply breaker on the building side. After 10 minutes or more, open the cover of the stationary battery charger. Examine the continuity of the charge cable. 		
		Continuity	Between charge plug (stationary battery charger side) CC1 terminal and V-PE connector (A) terminal (2) in stationary battery charger	Continuity
			Between charge plug (stationary battery charger side) PE terminal and PE terminal (B) in stationary battery charger	Continuity
3	Defective control circuit board	If no failure is found by above checks, the control circuit board is defective. (Because this is an internal defect, troubleshooting cannot be done.)		
4	Defective stationary battery charger	If no failure is found by above checks, the stationary battery charger is defective. (Because this is an internal defect, troubleshooting cannot be done.)		

- Disconnect the connectors (20), (21), (22), (23), (24), (25), (26), (27), (28), (29), (30), (31), and (32).

REMARK

For the label name of the wiring harness, see the figure.

- Remove the bolt (33), and remove the round terminals (3 pieces).
- Remove the bands (34) (11 places).
- Pull out the wiring harness (35) from the part (a).

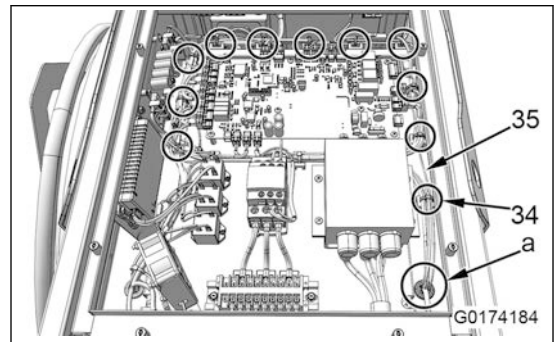
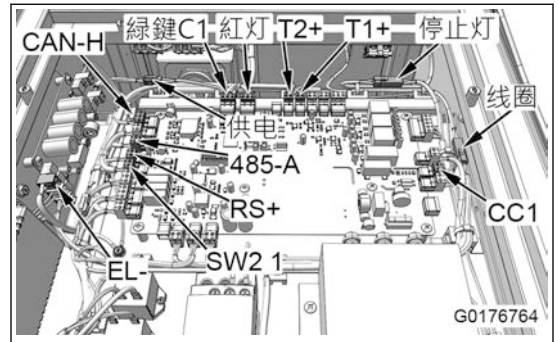
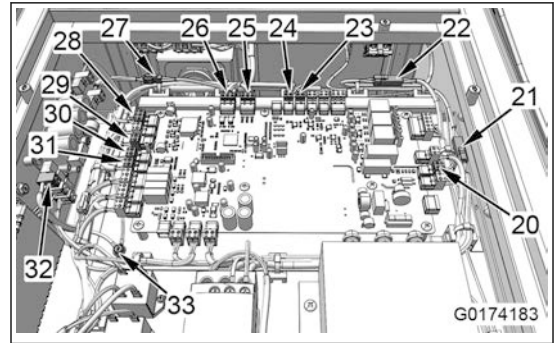

- Remove the bolts (36) (10 pieces), and remove the front cover (37).

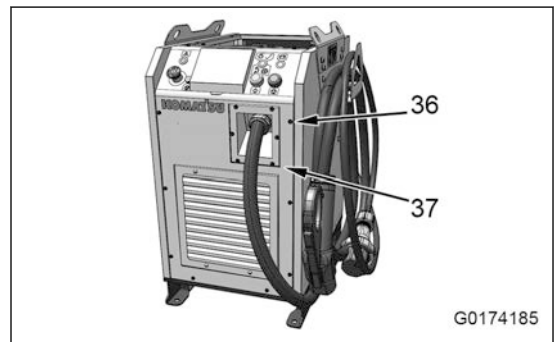

- Remove the bolts (38) (6 pieces), and remove the charge cable assembly (39).

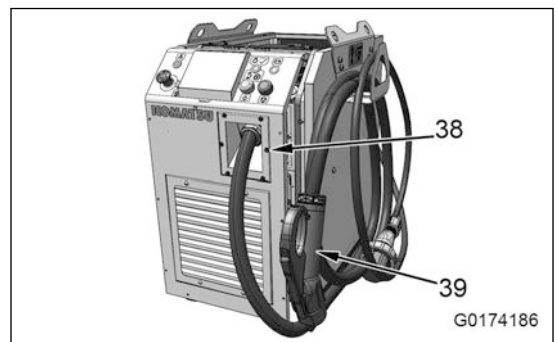

How to Install Contactor Cooling Fan

Contacting cooling fan

1. Install the contactor cooling fan (8) with the screws (7) (4 pieces).

REMARK

The screw (7) cannot be used again. Replace it with a new one.

 Screw (7): Liquid adhesive (LT-2)

 Screw (7): 0.98 to 1.27Nm{0.10 to 0.13kgfm}

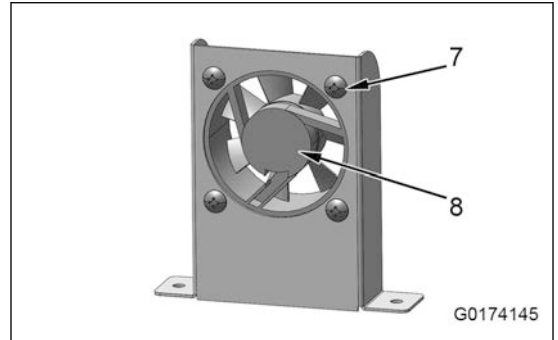

2. Install the contactor cooling fan assembly (6) with the screws (5) (2 pieces).

 Screw (5): 0.98 to 1.27Nm{0.10 to 0.13kgfm}

3. Connect the contactor cooling fan relay connector (4).
4. Install the band (3).

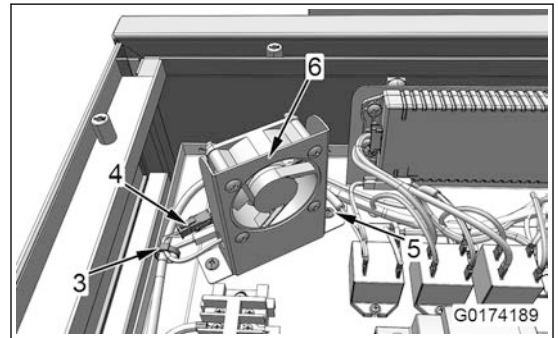

5. Install the upper cover (2) with the bolts (1) (8 pieces).

 Bolt (1): 5.0 to 5.5Nm{0.51 to 0.56kgfm}

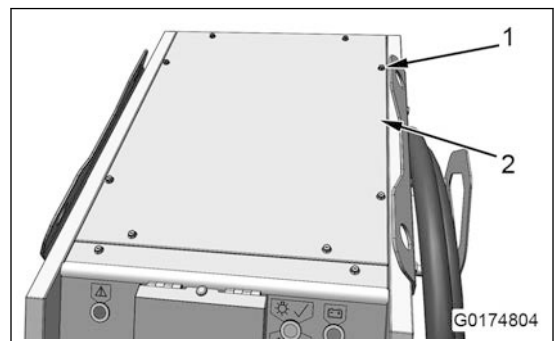

CLICK HERE TO **DOWNLOAD** THE COMPLETE MANUAL

- Thank you very much for reading the preview of the manual.
- You can download the complete manual from: www.heydownloads.com by clicking the link below



- Please note: If there is no response to CLICKING the link, please download this PDF first and then click on it.

CLICK HERE TO **DOWNLOAD** THE COMPLETE MANUAL