

Shop Manual

**HYDRAULIC
MINING
SHOVEL**

PC3000-6

**SERIAL NUMBER 06208 and up
46151 and up**

Unsafe use of this machine may cause serious injury or death. Operators and maintenance personnel must read this manual before operating or maintaining this machine. This manual should be kept near the machine for reference and must be periodically reviewed by all personnel who will come into contact with it.

Komatsu has Operation and Maintenance Manuals written in other languages. If a foreign language manual is required, contact your local distributor for availability.

KOMATSU

CLICK HERE TO **DOWNLOAD** THE COMPLETE MANUAL

- Thank you very much for reading the preview of the manual.
- You can download the complete manual from: www.heydownloads.com by clicking the link below



- Please note: If there is no response to CLICKING the link, please download this PDF first and then click on it.

CLICK HERE TO **DOWNLOAD** THE COMPLETE MANUAL

2.4 GENERAL PRECAUTIONS COMMON TO OPERATION ON THE EXCAVATOR

WARNING

WHEN MISUSED, THESE MACHINES ARE DANGEROUS.

Mistakes in operation, inspection, or maintenance may result in personal injury or death.

Before carrying out operation, inspection, or maintenance, always read this manual and the safety labels on the machine carefully and obey the warnings.

2.4.1 UNDERSTANDING THE MACHINE

Before operating the machine, read this manual thoroughly. If there are any places in this manual that you do not understand, ask the person in charge of safety to give an explanation.

2.4.2 PRECAUTIONS BEFORE STARTING OPERATION ON THE EXCAVATOR

2.4.2.1 ENSURING SAFE OPERATION

- Only trained and authorized personnel can operate and maintain the machine.
- During operations, personnel **are not** allowed outside of the operator's cabin.
- Follow all safety rules, precautions and instructions when operating or performing inspection or maintenance on the machine.
- If you are not feeling well, or are under the influence of alcohol or medication, your ability to safely operate or repair your machine may be severely impaired putting yourself and everyone else on your jobsite in danger.
- When working with another operator or with a person on worksite traffic duty, discuss the content of the operation beforehand and use pre-determined signals when carrying out these operations.

2.4.3 PREPARATIONS FOR SAFE OPERATION

2.4.3.1 PRECAUTIONS REGARDING SAFETY RELATED EQUIPMENT

- Be sure that all guards, covers and mirrors are in their proper positions. Have guards and covers repaired immediately if they are damaged.
- Understand the method of use of safety features and use them properly.
- Never remove any safety features. Always keep them in good operating condition.

2.4.3.2 INSPECTING THE MACHINE

Check the machine before starting operations. If any abnormality is found, do not operate the machine until repairs of the problem location have been completed.

2.4.10.4 PRECAUTION IN COLD AREAS

- Carry out the warming-up operation thoroughly. If the machine is not thoroughly warmed up before the control levers or control pedals are operated, the reaction of the machine will be slow or the machine may move in a way not expected by the operator. Particularly in cold weather, be sure to carry out the warming-up operation thoroughly.
- If the battery electrolyte is frozen, do not charge the battery or start the engine with a different power source. There is a hazard that this will ignite the battery and cause the battery to explode.
- Before charging or starting the engine with a different power source, melt the battery electrolyte and check that there is no leakage of electrolyte before starting.

2.4.11 OPERATION

2.4.11.1 CHECKS BEFORE OPERATION

If the checks before starting are not carried out properly, the machine will be unable to display its full performance, and there is also danger that it may lead to serious personal injury or death.

When carrying out the checks, move the machine to a wide area where there are no obstructions, and operate slowly. Do not allow anyone near the machine.

- Always fasten your seat belt.
- Check that the movement of the machine matches the display on the control pattern label in the cabin. If it does not match, replace it immediately with the correct control pattern label.
- Check the operation of the gauges and equipment, and check the operation of the bucket, arm, boom, travel system and swing system.
- Check for any problem in the sound of the machine, vibration, heat, smell, or gauges; check also that there is no leakage of oil or fuel.
- If any problem is found, carry out repairs immediately.

2.5.2 PRECAUTIONS FOR INSPECTION AND MAINTENANCE

2.5.2.1 PRECAUTION WHEN WELDING

⚠ WARNING

RISK OF EXPLOSION AND FIRE!

Welding, flame-cutting and grinding work on the machine increases the risk of explosion and fire which may result in serious injury or death.

All relevant safety measures must be followed and only under expressly obtained authorization.

Welding operations must always be carried out by a qualified welder and in a place equipped with proper equipment. There is a hazard of gas, fire, or electrocution when carrying out welding, so never allow any unqualified personnel to carry out welding.

2.5.2.2 BATTERY HANDLING

⚠ WARNING

RISK OF EXPLOSION AND FIRE!

Battery electrolyte contains sulphuric acid, and batteries generate flammable hydrogen gas, which may explode. Wrong handling can lead to serious injury or fire. For this reason, always observe the following precautions.

- Do not use or charge the battery if the battery electrolyte level is below the LOWER LEVEL line. This may cause an explosion. Check the battery electrolyte level periodically and add distilled water to bring the electrolyte level to the UPPER LEVEL line.
- When working with batteries, always wear safety glasses and rubber gloves.
- Never smoke or use any flame near the battery (Fig. 2-48).

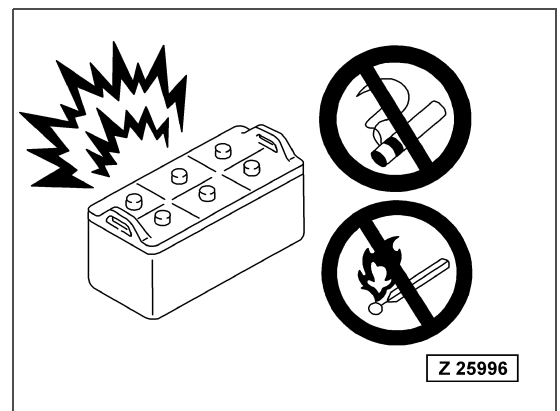

Fig. 2-48

- If you spill acid on your clothes or skin, immediately flush the area with large amount of water.
- If acid gets into your eyes (Fig. 2-49), flush them immediately with large amount of water and seek medical attention.
- Before working with batteries, activate the STOP switch and remove battery main switch key.

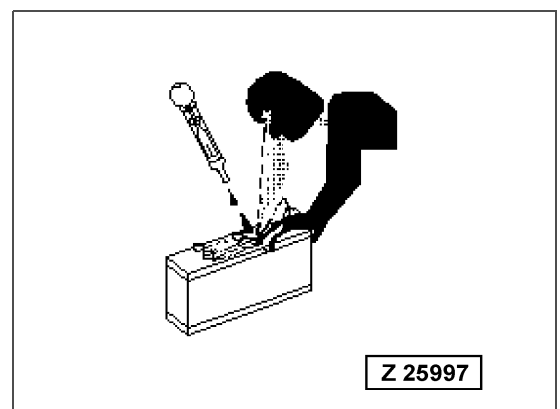

Fig. 2-49

2.7.5.5 INSTRUCTIONS FOR USE

Strap-Type Fall Absorber acc. to DIN EN 355 (Type E.K.N.-BFD)

Use

Within a fall-arrest system, the strap-type fall absorber (2) has to be used in conjunction with a safety harness (1) acc. to DIN EN 361. The maximum length including the safety rope must not exceed 2.0 m. For longer ropes, a rope-shortening device has to be applied in addition.

Fix the rope to the attachment point and attach the strap-type fall absorber to the catching hook in the back of the safety harness. The attachment point should be above the wearer and its minimum carrying capacity should be 10 KN, acc. to DIN EN 795.

The strap-type fall absorber and the safety rope must not be damaged, e.g. never pull them over sharp edges nor get them burnt by welding sparks.

Storing and maintenance

The strap-type fall absorber has to be kept dry in an airy and shady room. It must not be exposed to acids, caustic chemicals, nor to an aggressive atmosphere, and contact with oils has to be avoided. If the strap-type fall absorber is dirty, it may be cleaned with a little water and a light-duty detergent. Dry it in a shady place (nowhere near fire or other sources of heat). Protect it from sharp-edged objects.

Inspection

Prior to use, all parts have to be inspected for safe condition and damages. At least once a year, the strap-type fall absorber has to be tested by a competent person. A damaged or used strap-type fall absorber has to be removed from service immediately. The strap-type fall absorber must not be changed in any way.

Large Comfortable Cab

Gives full shift comfort

- Komatsu low noise cab on multiple viscous mounts for reduced noise and vibration.
- Large volume cab with deep front window.
- Comprehensive climate control with pressurised filtered air ventilation and air conditioning.
- High specification multi-adjustable air suspension seat.
- Well elevated operator position giving good all round view.

**MATCHED FOR
85 to 165 U.S. ton
TRUCKS**

**SHOVEL AND BACKHOE
BUCKET CAPACITY**

15 m³ 19.5 yd³



Advanced Hydraulics

Extended reliability and control

- Electronic pump management.
- Comprehensive monitored filtration.
- Simple open circuit hydraulic system with high efficiency swing out oil coolers.

Powerful Diesel Engine

Single Komatsu SSA12V159 engine

- Rated 940 kW 1260 HP, at 1800 rpm.
- Electronic engine management.
- Low engine emission levels meet EPA regulations.
- Optional time saving oil management system; Sentinel Engine Oil Management, Engine Reserve Oil Supply and Eliminator Oil Filter systems.

Easy and Safe Maintenance

Simple, common-sense design gives quick easy access to all major components

- Hydraulically operated ground access ladder; 60° angle with located bottom step.
- Generous access to all major service points from machinery house floor level.
- Enclosed, internally lit machinery house with firewall separating engine from pump area.
- Automatic central lubrication.
- ETM electronic monitoring system providing real time information about the operating status of the machine.
- Ground-level access to hydraulically powered swing down service arm with Wiggins connections.

1 INTRODUCTION

2.4.3.3 WEAR WELL FITTING CLOTHES AND PROTECTIVE EQUIPMENT

- Do not wear loose clothing and accessories. If these catch on the control levers or moving parts, there is a danger that it may cause the machine to move unexpectedly.
- Always wear a hard hat and safety shoes when working on the machine outside of the cabin. If the nature of the work requires it, wear safety glasses, mask, gloves, ear plugs and a safety belt when operating or maintaining the machine (Fig. 3-2).
- If you have long hair and it hangs out from your hard hat, there is a hazard that it may get caught up in the machine, so tie your hair up and be careful not to let it get caught.
- Check that all protective equipment functions properly before using it.

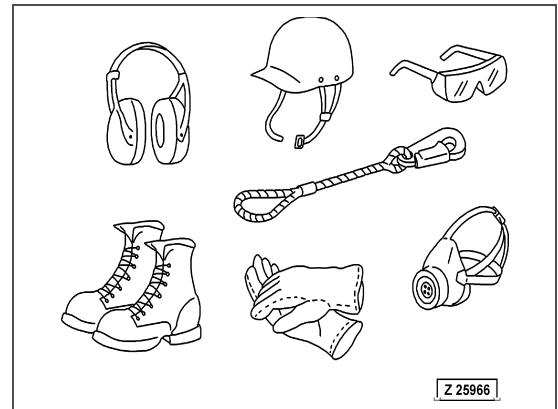

Fig. 3-2

2.4.3.4 KEEP MACHINE CLEAN

- If you get on or off the machine or carry out inspection or maintenance when the machine is dirty with mud or oil, there is a hazard that you will slip and fall. Wipe off any mud or oil from the machine. Always keep the machines clean.
- If water gets into the electrical system (Fig. 3-3), there is a hazard that it will cause malfunctions or a misoperation. If there is any misoperation, there is a danger that the machine may move unexpectedly and cause serious personal injury or death. When washing the machine with water or steam, do not allow the water or steam to come into direct contact with electrical components.

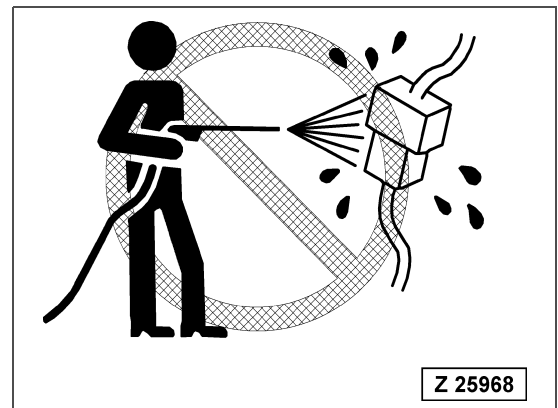

Fig. 3-3

2.4.3.5 PRECAUTIONS INSIDE OPERATOR'S COMPARTMENT

- When entering the operator's compartment, always remove all mud and oil from your shoes. If you operate the pedal with mud or oil affixed to your shoes, you may slip and this may cause a serious accident.
- Do not leave tools or machine parts lying around inside the operator's compartment. If tools or parts get into the control devices, they may obstruct operation and cause the machine to move unexpectedly, resulting in serious personal injury or death.
- Do not stick suction pads to the window glass. Suction pads act as a lens and may cause fire.
- Do not use a cell phone when driving or operating the machine. This may lead to mistakes in operation, which could cause serious personal injury or death.
- Never bring any dangerous objects such as flammable or explosive items into the operator's compartment.

2.4.11.2 PRECAUTIONS WHEN TRAVELLING IN FORWARD OR REVERSE

- Before travelling, set the machine so that sprocket (1) is behind the operator's seat (Fig. 3-21).
- If sprocket (1) is in front of the operator's cab, the machine moves in the opposite direction from the operation of the pedals (front and rear travel is reversed, left and right steering is reversed). Be extremely careful when operating the machine in this situation.

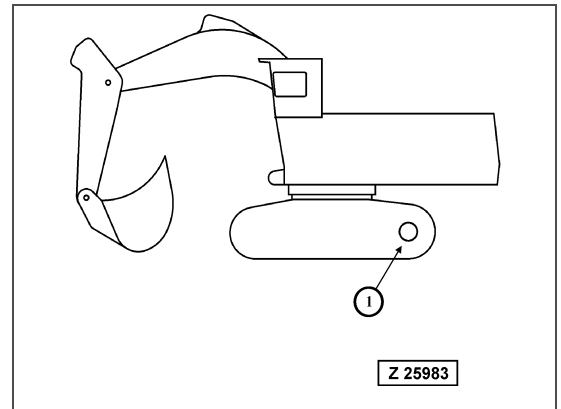

Fig. 3-21

- Before travelling, check again that there is no one in the surrounding area, and that there are no obstacles (Fig. 3-22).
- Before travelling, sound the horn to warn people in the area.
- Always operate the machine only when seated.
- Do not allow anyone apart from the operator to ride on the machine.
- Check that the travel alarm works properly.
- Secure the cab door when it is both open and closed.
- Always keep the cab door closed when operating the machine.

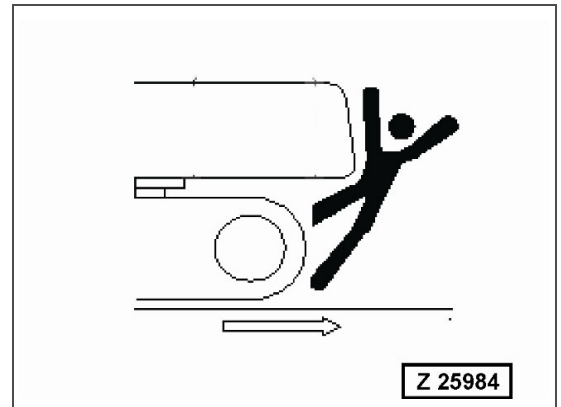

Fig. 3-22

- If there is an area to the rear of the machine which cannot be seen, position a signal person. Take special care not to hit other machines, objects or people when turning or swinging the machine (Fig. 3-23)

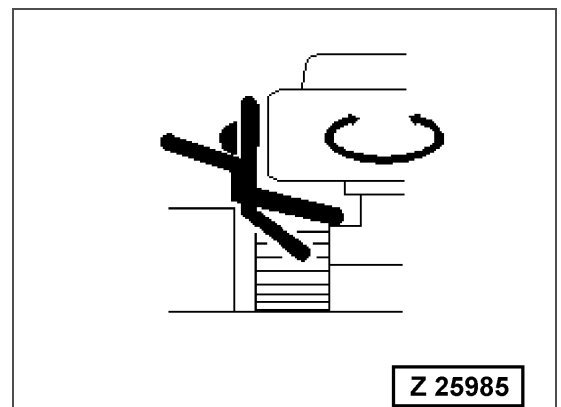

Fig. 3-23

NOTE! Always be sure to carry out the above precautions even when the machine is equipped with mirrors or camera systems.

- This storage period is part of the usable lifetime and must be considered when installing a new hose line. If, for example, a hose line with a one year storage time is to be installed, the remaining service life of the hose line must be considered. All hose lines are marked with the date of production.
- Hose lines considered as Safety Critical Parts have to be replaced earlier. Refer to the chapter "Lubrication and Maintenance Schedule" in the MAINTENANCE section of the Operation and Maintenance Manual for further information.

All hydraulic hoses of the Shovel have to be replaced when their service life has expired, even if there is no visible damage. Refer to the chapter "Lubrication and Maintenance Schedule" in the MAINTENANCE section of the Operation and Maintenance Manual for further information.

NOTICE

Repairs on hydraulic hoses are not allowed. Use ONLY GENUINE Komatsu Mining Germany replacement hose lines.

2.5.3.4 INSPECTION OF HOSE LINES

WARNING

FLUID UNDER HIGH PRESSURE!

The hydraulic system is always under internal pressure and can lead to serious injury when leaking. When inspecting or replacing piping or hoses, always check that the pressure in the hydraulic circuit has been released.

Inspect all hoses, hose lines and fittings carefully during the course of the daily walk-around inspection. Check for leaks and damages. Beware of pinhole leakages. Replace damaged parts without delay.

Some examples of faults on hydraulic hoses requiring replacement of the concerned part:

- Damage to the outer layer (e.g. chafed spots, cuts or scratches).
- Brittle top layers. Flaws on the hose material
- Distortion of the hose line (strong deviation from the original shape) under pressurized and pressureless conditions or when kinked or crushed, e.g. disintegration of hose layers or blistering.
- Leaks.
- Detachment of hose and fitting. Damaged hose fitting.

2.5.3.5 PERIODIC REPLACEMENT OF SAFETY CRITICAL PARTS

To ensure safety at all times when operating the machine, the user of the machine must always carry out periodic maintenance. In addition, to further improve safety, the user should also carry out periodic replacement of the parts given in the table. These parts are particularly closely connected to safety and fire prevention.

With these parts, the material changes as time passes, or they easily wear or deteriorate. However, it is difficult to judge the condition of the parts simply by periodic maintenance, so they should always be replaced after a fixed time has passed, regardless of their condition. This is necessary to ensure that they always maintain their function completely. However, if these parts show any abnormality before the replacement interval has passed, they should be repaired or replaced immediately.

If the hose clamps show any deterioration, such as deformation or cracking, replace the clamps at the same time as the hoses.

When replacing the hoses, always replace the O-rings, gaskets, and other such parts at the same time.

3. SPECIFICATIONS

4 MAIN ASSEMBLY GROUPS

Legend for illustration (Z 24026):

- A** View from machine back side
- B** View from machine left side
- C** Top view

- 1 Counter weight (welded box design)
- 2 Lifting eye (fix mounted)
- 3 Lifting eye (mounted only for transport)
- Sx Point of gravity, 2215 mm
- Sy Point of gravity, 1200 mm
- W Minimum rope angel = 40° ,
- L Rope length single 2,5 - 3 m, min. 20 ton
- A** View from machine back side
- B** View from machine left side
- C** Top view

Prime Drive Assembly

Legend for illustration Z 22176

- 1 Diesel Engine
- 2 Torsion type coupling (diesel drive)
- 3 Pump distributor gear (PTO)
- 4 Adapter flange
- 5 Torsion type coupling (electric drive)
- 6 Electric motor

General

The PC 3000 diesel is driven by a Komatsu diesel engine:

Model:	SSA 12 V 159
Type:	4-cycle, water-cooled, direct injection
Aspiration:	Turbocharged and after cooled
Number of cylinders	12
Rated power	940 kW (1269 HP) @ 1800 rpm
Governor	All-speed, electronic

The engine is controlled by two signal lines for the main fuel valve and the RPM control. Engine monitoring sensors direct connected to relays and modules in the cab base. Visual monitoring by text display and gauges at the dash board.

Legend for illustration Z22186a

1	Gear pump
2	Pressure filter
3	Relieve valve block
4	Cooler inlet line (hot oil)
5	Cooler inlet
6	Cooler outlet
7	Return line to PTO (cold oil)
8	Relieve line form relieve valve (cooler by pass)
9	PTO cooler
10	Gear box (PTO)
11	Suction line
12	Solenoid valve (by pass controlling)
13	Drain line from relieve valve
14	Temperature sensor B49-1
15	Temperature sensor B182
16	Pressure switch B17-1

Description

A external gear pump (1) aspirate gear oil from the gear box sump (10) and pumps it through a cooler (9) back to the gear box. The lubrication and cooling circuit is protected by a filter (2) and a pressure relieve valve (3).

The gear oil coolers (9) are a small part of the hydraulic oil coolers thus the gear oil gets cooled by the same air stream as the hydraulic oil. From the coolers the oil flows to the spray nozzle port of the gear box via return line (7). The spray nozzle insure proper and adequate distribution of the oil to lubricate and cool down the gears and bearings.

The circuit is monitored by the pressure switches B17-1 (16). With to low lube oil pressure (<0,5 bar) a fault message will be displayed at the text monitor of the dash board in the cabin.

The gear oil temperature is monitored by the temperature sensor B49-1 (14). If the temperature increase to the specified temperature a fault message will be displayed at the text monitor of the dash board in the cabin.

With low oil temperature a second temperature sensor B182 (15) activates solenoid valve Y53-1 (12) to reduce the release pressure of the pressure relieve valve so the main oil flow by pass direct back to the gear box via relieve line (8).

The connection to the suction tank can be closed with the main gate valve (13) to prevent oil flow during repairs. This unit is controlled by the switch S31, it make sure a engine start is not possible with a closed main gate valve. Fault message „**Start blocked because of main Shut-Off (gate) valve**“ is displayed at the operators dash board.

The suction oil tank is a welded sheet-metal construction. The oil capacity of the suction oil tank and connecting pipe is together 102 liters.

A main screen filter in the line between main oil reservoir and suction tank protect the pumps for solid gross oil contamination. Additional screen filters in the aspiration line to each main pump protect the suction tank and the other pumps for contamination through a failed main pump.

WARNING

It is important to clean the screen filters in the pump suction line according to the maintenance manual and after a pump replacement.

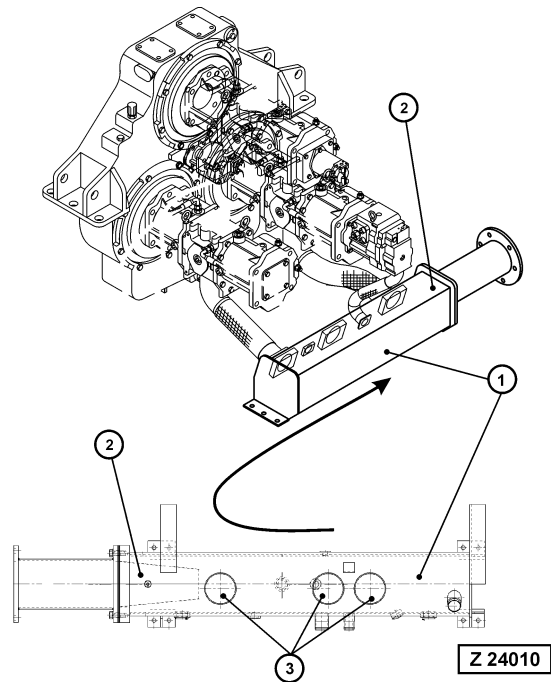

Legend for illustration Z 25231

- | | |
|----|-----------------------------------|
| 1 | Fan pump (HPF125) |
| 2 | Oil filter |
| 3 | Pressure line to valve and motors |
| 4 | Pressure relieve valve |
| 5 | Solenoid valve |
| 6 | Fan motor |
| 7 | Return line to reservoir |
| 8 | Pressure line to motor |
| 9 | Valve return line to reservoir |
| 10 | Check valve |
| 11 | Leak oil from motors |
| 12 | Leak oil from valve |

Function:

From the pump (1) the oil flows through the filter (2) and distributed to the fan motors (6) and the pressure relieve valve (4).

Return oil from the motors flows back to the reservoir or cooler via line (7) and the return oil collector tube.

The check valve (10) acts as an anti cavitation valve to enable free oil circulation when the oil flow to the motor is stopped and the motor runs by its own momentum.

The fan drive circuit is protected by the pilot controlled pressure relief valve (4). This valve operates in relation with the solenoid valve (5) controlled by the hydraulic oil temperature.

With de-energized solenoid the relief valve opens by the adjusted pressure so that the fans run with the max. speed. With energized solenoid the pilot pressure of the relief valve is drained to the tank so that the relieve valve pressure is reduced which cause that the fan speed is very low.

Adjustment

1. Connect reliable pressure gauges to the check points M1.1 (0 - 100 bar) and M1.2 (0-60 bar).
2. Start engine and let engine run in high idle. If hydraulic oil is not at operating temperature warm it up.
3. Read the pressure at the gauges.
 - M1.1 = X4 = 60 ± 3 bar
 - M1.2 = X2 = 35 ± 3 bar
4. If required adjust the X4 pressure with pressure relieve valve 252.2 (left cartridge) or X2 pressure with pressure regulation valve 252.1 (right cartridge).
5. Loosen lock nut
6. Set respective pressure with set screw. Turn set screw ccw to reduce the pressure and cw to increase it.
7. Tighten lock nut and.
8. Watch both pressure during adjustment because of a influence between each other.

Check sheet FSA Page 5

PC3000/6_Frontshovel

Ser. No.:

Date:

19 Right forw, Stick in
 Y132b Y132b Y132c

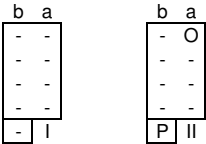
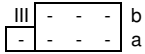

20 Right forw, Bucket fill
 Y132b Y132b Y132c

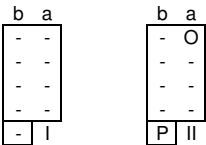
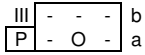

21 Right forw, Bucket empty
 Y132b Y132b Y132c

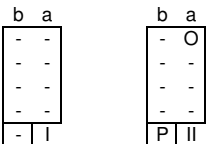
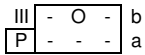

22 Right forw, Clam close
 Y132b Y132b Y132c

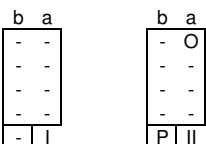
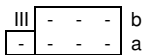

Check sheet BHA Page 6

29 Boom down, Stick out, Bucket empty, Swing right

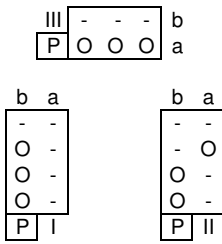

30 Boom down, Stick in, Bucket fill

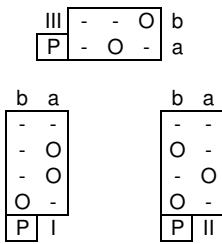

31 Boom up, Stick in, Bucket empty, Swing left

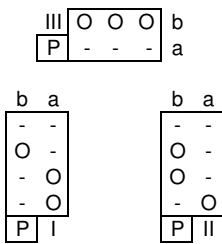

32 Boom up, Stick out, Bucket empty, Swing left

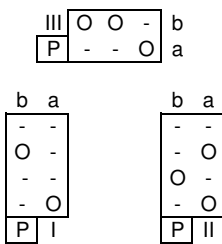

33 Boom up, Stick in, Bucket fill, Swing left

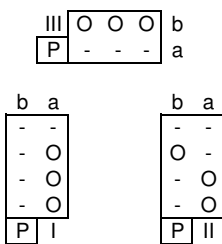

Legend for illustration Z 25279

Numbers in brackets are component numbers for the hydraulic diagram

Control block III

- 7 SRV (66.2), stick cylinder rod side
- 8 ACV (68.5), stick cylinder piston side
- 21 MRV block III

Function:

Main control valve Type MO:

Illustration Z 22217

Upper picture

Spool centering springs (1) keeps the spool (3) in neutral center position if there is no pilot pressure at pilot port a or b.

Precise control grooves (2) provide for sensitive controlling because a motion is started always while the pressure oil and the return oil first passes this fine control grooves before spool is inter connecting the entire groove to the service line port.

In neutral position of the spool (3) the pump oil flows back via port PU to outlet T and from there via pipes back in the oil reservoir.

Lower picture

The spool is pushed to the left position by pilot pressure at pilot port a. Port PU is closed and the connection through the check valve P1 to the service port A is open. Also the connection from the other service port B (return line) is connected to the port T (return line to reservoir).

Function

The auxiliary gear pumps are used for the pilot pressure circuit and PTO gear lubrication.

The illustrated gear pump type is SAL (2) 63 for PTO lubrication, with a oil delivery of 63 cm³/rev. The pilot oil pump from the same principle the type is SAR (3) 56 and a delivery volume of 56cm³/ rev.

Make sure to bleed the pump at the suction side for the first start after oil or pump exchange

All gear pumps are maintenance and adjustment free.

Main pump operating principals

Each main pump (1) consist two separate swash plate pumps (1a and 1b) and one central centrifugal charge pump (4). The pump drive shaft (9) transfers engine torque via the pump distributor gear box to the two single tandem pumps (1a and 1b) which are assembled in line. The suction chamber between the pumps is equipped with a centrifugal charge pump (4). The centrifugal pump is driven from the drive shaft via a bevel gear. Each tandem main pump (1a and 1b) leads the oil volume of its two single pumps together in one high pressure outlet line (10).

A electronic pump regulation controller (16) controls individually a proportional valve (servo valve) (2) of the pump control block (3) which controls via a internal valve and a control piston the swash plate angel. The swash plate angel determine the pump delivery per revolution [$V_g = \text{cm}^3/\text{rev}$]. The whole pump regulation system is called **Electronic Pump Control EPC**.

The pump control block (3) of each main pump (1a and 1b) needs external hydraulic oil supply (7) of 35 +3 bar, it supports the swash plate control system until the pump outlet pressure is high enough to supports the regulation system.

A pressure transducer (10) in the outlet line of each main pump monitors continuous the respective pump pressure and send the pressure signal to the electronic pump regulation controller (16). The electronic pump regulation controller (16) use the pump outlet pressure and the engine speed signal from the speed pic up (13) to control the pump delivery via proportional valves (2).

Only the electronic pump controller (16) controls the main pumps (1), there is no additional hydraulically controlling equipped.

The pump regulation controller is divided in two main function.

1. Pump regulation

The pump regulation reduce the pump intake power via the pump delivery (reduced swash plate angel) to the maximum engine output power Z 25141. With no regulation the pump intake power exceed under full hydraulically load the maximal engine power so that the engine stall to much, low revolutions means low output power and low machine performance. For this reason the pump regulation try to regulate the pump intake power to the maximal engine output power which is achieved at 1800 1/min engine revolutions. If the hydraulic system is under load and the pumps stalls the engine to 1800 1/min or below the regulation system reduce the pump delivery (reduced pump intake power) just to keep the 1800 1/min.

2. Cut off function (CO)

The cut off (CO) function reduce the pump output flow to Q_{\min} just before the main relieve valve (MRV) opened to limit the pump output pressure, Z 25140. The CO prevent a full oil flow through the main relieve valve (MRV) back in the oil tank when the service line oil flow is restricted or blocked, like a restricted bucket in the wall or a cylinder in final stop. Without CO function is the oil flow through the MRV to high, the hydraulic oil temperature increases unnecessarily and the valve size is to small so that the restricted high oil flow cre-

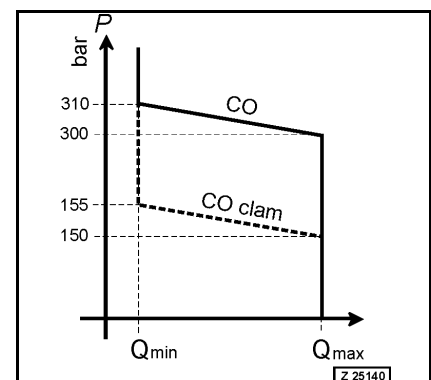
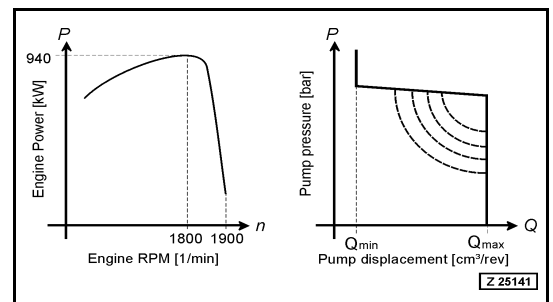

General

The pump regulation is working as a engine load limiting system to ensure optimum use of the power required for the excavator under varying operating conditions and to avoid overload of the engine. With an undesirable overload of the engine the engine rpm drops under the maximum engine output power (max. power by 1800 1/min) and results in bad excavator performance up to engine problems.

The main engine load indicator is the engine rpm, it is indicated by a pic up (rpm sensor) at the engine fly wheel. The frequency of the sensor is proportional to the engine rpm and direct connected to the pump controller CR700. If the engine rpm is more as 1800 1/min the controller moves the main pumps via the EPC proportional valves to maximum output volume (Qmax). If the engine rpm is stalled to 1800 1/min or lower the pump controller reduce via the EPC proportional valves the pump output volume to limit the pump power just to keep the engine at 1800 1/min (maximum engine power).

Independent of the engine load the pump controller CR700 reduce the pump output volume to Qmin if the pump pressure increase up to 312 bar. The pump output pressure signal comes from the pressure transducer at the high pressure filter: This function is called "cut off function" to prevent high oil flow (Qmax) through the main relieve valves (MRV) in time when the oil flow is restricted or blocked like a cylinder in final stop position.

Selected pilot signals from the X2 board are connected to the pump controller CR700. This signals are used to give different main pump priorities of the torque and volume distribution during selected excavator functions. E.g. with activated swing system the respective pump is out of the regulation (torque priority) so that the swing system operates with fixed pump volume. In the same time the controller lower the pump volume to a pre set value so that there is no over speed risk for the swing motor (volume distribution).

10.7.8 Table of fault messages and adjustments

Abbreviations	Description
MM	Multi Monitor
EPC	Electronic Pump Controller
P1....P6	Pump 1.....Pump 6
SOL	Solenoid
RPM	Rounds Per Minute
Qmin / Qmax	Minimum / Maximum pump displacement

The following tables show all possible pump controller generated fault messages with additional information about:

- fault message description - refer to "Fault message description" on page 273
- controller in- and output condition to generate the respective fault message - refer to "Failure code and detection logic" on page 274
- main pump situation and controller action at the time of failure occurrence - refer to "Situation and reaction after fault" on page 275
- Required condition or action to reset the pump regulation system after fault eliminating - refer to "Trouble shooting and fault message reset" on page 276
- Trouble shooting guide - refer to "Trouble shooting and fault message reset" on page 276

For all possible items of menu 04 "Adjustment" refer to "Controller Adjustment table" on page 280

Fault message description

Failure message (display)	Description
P1 EPC SOL Short circuit	Electrical connection of solenoid valve from Electronic Pump Controller shorted to ground
P1 EPC SOL Disconnection	Electrical connection of solenoid valve from Electronic Pump Controller disconnected
P1_2 Pump pressure sensor abnormality	Wrong electrical signal from pressure transducer of pump X_Y
Sensor power supply abnormality	Wrong power supply tension of pressure transducer from the main pumps
Engine speed sensor abnormality	Wrong tension signal of engine speed sensor (pick up at flywheel)

Legend for illustration Z 22251

1	Main control blocks
3	Rotary joint
4	Travel motors
5	Attachment cylinder
6	Swing motor
7	Distributor manifold

All other numbers are component numbers from the hydraulic diagram.

Function:

From the control blocks (I, II, III) the oil returns via return oil pipes and the return oil collector manifold (15) into the tank whenever the spools of the control blocks are in neutral position. On its way to tank the oil must pass the back pressure valve (25) and the return oil filters (50.2, 50.2, 50.3).

The function of the back pressure valve (25) ensures:

- enough oil supply for all anti-cavitation valves
- enough oil flow through the oil coolers

If the operator starts a movement the relevant spool in the control block allows the flow from the pump to the chosen attachment cylinder either piston or rod end or to the travel or swing motor. From the opposite side of the cylinder or motor the oil returns to the control block and from there via the return oil pipes through the filters back to the tank.

Each circuit is provided with one MRV and at least one SRV (3) and ACV.

To limit the lowering speed of the attachment there are throttle check valves in the relevant service line see illustration Z 25299. The throttle valves are only in circuits where the gravity can move the cylinder. To limit the gravity supported cylinder moving the throttle valve restrict the return oil flow. flow from (5) to (4). In the opposite direction from (4) to (5) which is only pump pressure supported a internal check valve opens so that there is no flow restriction. The speed must be limited to prevent cavitation in the cylinder supply line and to limits the return oil flow through the valve blocks to prevent erosion and cavitation in the blocks.

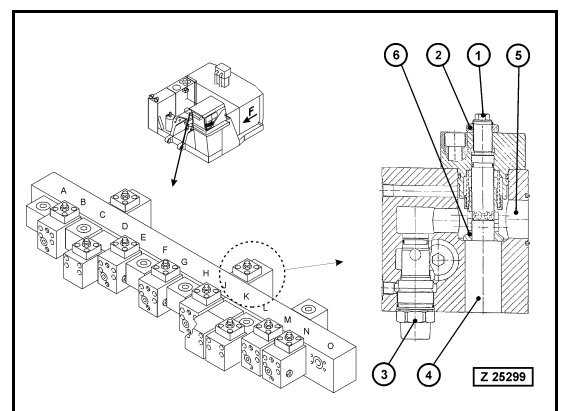

Table 2: SRV location chart BHA

Function	Qty total	Location	SRV Component No.	Section Position Port No.(*)	Pressure [bar]
boom up	3	Manifold	63.8	B, rear	350
		Manifold	63.9	N, rear	350
		Manifold	63.10	D, rear	350
boom down	1	Block II	66.3	B1, left	350
stick out	3	Manifold	63.3	E, rear	350
		Manifold	63.5	J, front	350
		Manifold	63.6	J, rear	350
stick in	3	Block I	66.8	A2, right	350
		Block II	66.7	B3, left	350
		Block III	66.2	B3, left	350
bucket fill	3	Manifold	112.2	C, front	350
		Manifold	70	M, front	350
bucket dump	2	Manifold	63.4	G, rear	350
		Manifold	63.7	L, rear	350

* Section: Section of the distribution manifold,
 Position: front or rear of the manifold in operation direction
 Port No. from the control valve block

Legend for illustration Z25305

1	Drive housing
2	Drive shaft
3	Sun gear shaft
4	Multi disc brake, spring loaded pilot pressure released
5	Breather filter motor adapter housing
6b	Oil level gauge (dip stick) motor adapter housing
7	Disc brake housing
8	Cylindrical roller bearing
9	Internal ring gear
10	Cylindrical roller bearing
11	Bearing ring
12	Cartridge
13	Spherical roller bearing
14	Oil drain plug, gear box
15	Cylindrical roller bearing
16	Oil level gauge (dip stick) gear box
17	First planetary stage
18	Drive shaft to second stage
19	Second planetary stage
20	Radial seal ring
21	Drive pinion
22	Grease line port
23	Centering circle

Description

The slew gear is of compact design with a two stage planetary gear including a multi disc house brake. The gear is bolted to the superstructure and fits firmly due to the fine machined centering circle (23) and the bolt force. The torque loaded on the hydraulic motor is transmitted by the drive shaft (2) to the first planetary stage (17). The sun shaft (16) transmits the torque from the planetary support from the first stage (17) to the sun shaft (18) of the second stage (19). By the planetary gears the output drive shaft rotates and transmits the torque to the pinion (21).

The drive housing and the gear box are filled with gear oil. The aeration of the compartments is done by breather filters. The bottom roller bearing is lubricated external via a lubrication port (22) to the central lubrication system or manually via a grease nipple.

Legend for illustration Z 22270a

1	Main pump I
2	Main pump II
3	Main pump III
9	Main control block I
10	Main control block II Main control block III
14.1	Travel brake valve block left
14.2	Travel brake valve block right
58	Rotary joint
59.1	Travel motor left
59.2	Travel motor right
62	Travel control pedal left
74	Travel control pedal right
75.1	Shuttle valve pilot line left
75.2	Shuttle valve pilot line left
75.3	Shuttle valve pilot line left / right
76.1	Pressure switch B37 pilot pressure monitoring 7 bar

Function

The travel system is divided in two separate circuits. One for the left track and the second for the right track. Each circuit is supplied by one pump. Left track from pump I (1) via control block I (9) and the right track from pump II (2) via control block II (10).

Control pedal (62) controls the left track and (74) the right track. In the pilot line are shuttle valves connected which leads the pilot oil independent from the pressurized travel pilot line to pressure switch B37. The electrical signal from pressure switch B37 is used to give the travel function in control block I and II priority over the attachment function because the travel spool valve is the last in the control block and have the last hydraulically priority.

When operating the control pedals for travelling pump oil flows via the activated control block through the rotary joint and the travel brake valve to the respective travel motor.

The rotary joint enables a hydraulic oil flow through the center of the machine from the superstructure to the car body independent from machine rotation.

The travel brake valve protects the travel motors from over speeding during down hill traveling.

12. TRACK TENSION SYSTEM

Functional test after adjustment:

1. Bleed all air from the system. Connect pressure check hoses to check point M29.1, 29.2, 29.3, 29.4 at all tensioning cylinder.
2. Make sure that the shut off valves (87), (89.1), (89.2) and (89.3) are in operating position.
3. Connect a pressure (0 -400 bar) gauge to one of the check points M29.x
4. Start engine and let it run in high idle.
5. The gauge pointer should increase slowly up to 35 bar.
6. Travel the machine in one direction. Watch the gauge. The gauge pointer should show pressure peaks with more as 35 bar.
7. Unplug solenoid valve Y16 at the valve and filter frame. The pressure should decrease back to 35 bar to the low pressure setting of the PIV.
8. Stop engine
9. Remove gauges. Reconnect plug of solenoid valve Y16.

NOTICE

The pressure may drop to a lower pressure as 35 bar after a while because of internal leaks and decreasing temperature.

Function of service arm control

If the service arm is in up position the electrical proximity switch S23 is activated and the engine is running the solenoid valves energize Y124a (33.2) and Y 124c (259.2) and pressurize the piston side of the service arm cylinder (121) so the piston side of the cylinder is permanent pressurized. It keeps the service arm permanent against the upper final stop without a additional mechanical lock.

If the service arm is out of the proximity switch and there is no manual pull switch activated all solenoid valves Y124a, Y124b and Y124c are de-energized and the cylinder is hydraulically blocked.

NOTICE

Lifting of the service arm is only possible with running engine.

2. Engine is stopped

Only lowering is possible by stopped engine. Turn the main key switch into ON position and activate the enable switch. Pull the service arm control chain underneath the counter wight to lower the arm. It will activate the solenoids Y124b and Y124c and the arm will lower by gravity. The gravity force push the oil of the cylinder piston side through the open solenoid valve Y124c to port A of solenoid valve Y124b. From this solenoid valve the oil flows back to the tank via port T and the orifice (259.5). The rod site of the cylinder get oil via the anti cavitation valve (259.3)

Electrical explanation

See hints for reading the electrical diagram

To enable the service arm control it is necessary to activate the enable switch S94 at the dash board it cancel the power to the pilot control solenoid valves via the contact 6/2 of relay K146 and connect power to control switch S87 via contact 9/5. If the engine is running and the service arm in upper initial position there is power through switch S87 contact 21/22, K3a 7/11 and K145, 6/10 to relay K147 which activates solenoid valve Y124a and Y124c so the arm is automatically pressurized against the upper final stop. If the pull switch S87 is activated contact 13/14 connect power to time relay D48 which activates 1 sec via contact 15/18 alteration relay K158. The alteration relay K158 change after each power impulse at terminal A1 its contact condition. With repeatedly activated pull switch S87 the relay K158 change its contact condition and energize alternately relay K148 for service arm down or K147 service arm up. Every time when one of the solenoid valve Y124a or Y124b is activated the solenoid valve Y124c activates parallel to release the hydraulically lock of shut off valve (259.2) to the cylinder piston side. If the service arm is out of the proximity switch S23 relay K145 is de-energize which open the contact 6/10 to relay K147 and the automatically pressurized up function is canceled. In the same time relay K145 cancel the pilot control circuit via contact 4/12, activates the horn light circuit to the maximum filling monitoring system.

15.2.5 Pump, motor, cylinder

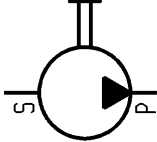
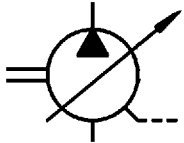
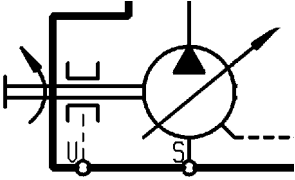
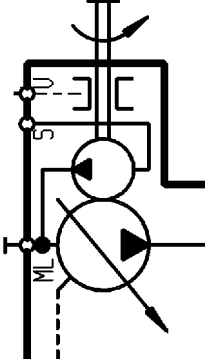
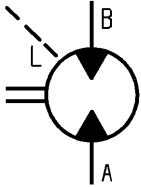
Item	Symbol	Description	Used as / at / on
54.		Drive shaft of a motor or pump with one direction	Main pumps, swing motor, fan drive, travel drive
55.		Hydraulic pump with fix volume per REV suction port S, pressure outlet P	Fan pump, pilot pump,
56.		Hydraulic pump with variable output volume per REV with external case drain	Main pump
57.		Hydraulic pump assembly with pump bearing lubrication, one direction and external case drain	Main pump
58.		Variable hydraulic pump with charge pump and external drive shaft bearing lubrication	Main pump
59.		Hydraulic motor can be used in both direction, with external case drain L	Fan motor

Explanation of the drawing concept

Legend for illustration Z 22375

1	Drawing number
2	Sheet number / quantity of sheets
3	Designation of drawing
4	Designation of component or assembly
5	Column (vertical sections)
6	Lines (horizontal sections)
7	Component symbol
8	Negative power line, machine ground
9	Designation of phase
10	Positive power supply line, coming from F12
11	Terminal, one of the X2 board terminal rail
12	Cable plug and pin number
13	Relay coil
14	Relay contacts, partially with detailed information
15	Cross reference, link to further connection
16	Indication of relay contact condition (open or close) and contact location

General Function

For maximum machine reliability and maximum lifetime the principal bearing points must be frequently lubricated with a sufficient amount of lubricant. For best lubricating reliability with minimum maintenance automatic lubrication system controlled from the PLC lubricates the any connected lubrication points in a adjustable time intervals with the required amount of lubricant as soon as the machine is in normal service.

The excavator is equipped with two independent lubrication systems. The CLS (**C**entral **L**ubricating **S**ystem) supplies the attachment bearings and swing ring bearing with grease. The SLS (Swing ring gear Lubrication System) supplies the open gear of the swing ring with grease.

The two independent lubrication systems are necessary because the bearing and the open gear teeth require different type of lubricants.

Adjustments lubricating pump speed

Stroke speed (Q)

For a sufficient lubricating pump operation 18 – 20 double strokes/ min of the pump drive cylinder are required. Therefore the flow reducing valve (2) has to be adjusted accordingly.

Procedure:

1. Disconnect electrical plug connection from the lubricant pressure release valve (9), so no pressure built up will take place during the following test.
2. Start engine and run at high idle.
3. Activate the required lube system manually with dash board switch S24 (CLS) or S26 (SLS) and count strokes per minute, visible via the oscillating pipe (24).

If adjustment is required:

4. Loosen lock nut (2.1)
5. Turn setscrew (2) cadre to increase or cr. to decrease the stroke speed until the right number of strokes is achieved.
6. Tighten lock nut (3.1).
7. Reconnect electrical plug from lubricant pressure release valve (9).

Lubricant in line filter

The in line filter between lubricant pump and injectors prevent a system contamination of rough particles. To prevent to high intake pressure with blocked filter the filter element is equipped with a by- pass function.

Maintenance procedure:

1. Remove plug screw (1) (36 mm spanner) with gasket (2)
2. Take out spring (6), spring guide (5) and filter element (3)
3. Clean all parts and inspect for damage.
4. Remove filter element (3), spring guide (5) and spring (6)
5. Install plug screw (1) with gasket (2), if necessary use new gasket.

Swing ring Lubrication System (SLS) function and controlling with ETM system

General:

Machines with ETM system use standard relays and time relays to control the lubrication system. The central lubrication system (CLS) and the swing ring lubrication system (SLS) use its independent own control system.

Function:

See illustration Z22023b, Z24027 and the respective electric and hydraulic circuit diagram of your machine. Behind component numbers in brackets the coordinates of electric plan Z24027.

As soon as the battery master switch is activated and circuit breaker F25 is closed the SLS system is permanent supplied with 24 V DC. Independent of the key switch S1 is the lubrication system supplied via line 30. Contact 1-2 of the end line pressure switch B46 is in pressureless condition connected and supply via different relay contacts relays and finally solenoid valves Y9 (main pump control solenoid valve, lubrication pump on / off) and Y9a (Lubricant pressure release valve).

1. Pause time condition (PT)

End line pressure switch B46 (E7) is in its initial electrical condition contact 1-2 is connected, electrical power is available to the relays via terminal X2 152-153. Until engine runs in high idle relay K45b (D7) energize and activates pause time relay D7 (C7) the pause time counting starts.

2. Lubrication starts (PI)

Until the time setting of pause time relay D7 (C7) is elapsed its contact D7 (D8) closes. The SLS lubrication system is ready to start but only after activated swing lever with activate swing monitoring relay K73 (E8) its contact close and now K37 (C8) energize and close its contact to activate pump solenoid valves Y9 (C3) and lubricant pressure release solenoid valve Y9a (C2) via fault relay contact K38 (E3). The lubrication pump starts and the pressure release line closed so the lubricant pressure can increase. Until all injectors have injected its adjusted amount of lubricant to the lubrication pinion the lubricant pressure in the supply line increases up to the end line pressure switch B46 (E7) setting of 180 bar.

3. Lubrication stops (S+, PR)

The activated end line pressure switch opened its contact 1-2 and closes 1-3. With open contact 2 time relay D7 (C7) de energize so that its contact D7 18-15 opened and relay K37 de energize. With de energized K37 solenoid valves Y9 and Y9a de energize, now the lubrication pump stops and the pressure release line opened and release the lubricant pressure back in the lubricant container (PR). With released lubricant pressure end line pressure switch B43 (C7) change back to the initial contact position 1-2 (S-) so that time relay D7 (C7) starts to count again the pause time (PT) up to the next lubrication.

7.3	BACK PRESSURE VALVE ADJUSTMENT	7-144
7.4	FAN DRIVE	7-146
7.4.1	FAN PUMP	7-148
7.4.2	PRESSURE RELIEVE VALVE	7-149
7.4.3	TEMPERATURE RELAY	7-151
7.5	COOLER FAN DRIVE ADJUSTMENT	7-152
8.	CONTROLLING	8-155
8.1	PILOT PRESSURE SUPPLY AND ADJUSTMENT.....	8-156
8.1.1	PILOT CONTROL ARRANGEMENT	8-158
8.1.2	PILOT PRESSURE ADJUSTMENT.....	8-160
8.1.3	CHECK OF CONTROL PRESSURE	8-162
8.2	SLEW BRAKES	8-164
8.3	TRAVEL PARKING BRAKE	8-167
8.4	CHECK OF THE PILOT CONTROL LOGIC	8-169
8.4.1	CHECK SHEET FSA PAGE 1	8-171
8.4.2	CHECK SHEET BHA PAGE 1	8-184
9.	COMPONENTS	9-193
9.1	MAIN CONTROL BLOCK AND VALVE ARRANGEMENT.....	9-194
9.1.1	FSA ARRANGEMENT	9-196
9.1.2	BHA ARRANGEMENT.....	9-200
9.2	DISTRIBUTOR MANIFOLD	9-204
9.2.1	FRONT SHOVEL ATTACHMENT FSA	9-204
9.2.2	BACK HOE ATTACHMENT BHA	9-206
9.2.3	SRV WITH THROTTLE CHECK VALVE	9-208
9.2.4	ANTI CAVITATION VALVE (CHECK VALVE).....	9-210
9.3	MAIN CONTROL BLOCK.....	9-212
9.3.1	LOAD HOLDING VALVE	9-218
9.3.2	HIGH PRESSURE FILTER.....	9-220
9.3.3	PRESSURE RELIEVE VALVES AND ANTI-CAVITATION VALVE	9-222
9.3.4	PRESSURE RELIEVE VALVES AND ANTI-CAVITATION VALVE.....	9-224
9.4	COMPACT VALVE BLOCKS	9-226
9.5	COMPACT VALVE BLOCKS	9-228
9.6	AUXILIARY GEAR PUMPS	9-230
9.7	HYDRAULIC CYLINDER	9-232
9.8	SWING RING.....	9-234
10.	MAIN HYDRAULIC PUMPS AND PUMP REGULATION	1-237
10.1	GENERAL	1-238
10.1.1	PUMP LOCATION	1-240
10.2	MAIN PUMP OPERATING PRINCIPLES	1-242
10.2.1	MAIN PUMP FUNCTION	1-247
10.3	MAIN PUMP CHECKS AND ADJUSTMENTS	1-250
10.3.1	PEAK POINT DIESEL ENGINE TEST.....	1-250
10.3.2	PRESSURE TRANSDUCER TEST	1-252

20. If the engine is operated for a long time in a place which is not ventilated well, you may suffer from gas poisoning. Accordingly, open the windows and doors to ventilate well.

PRECAUTIONS WHEN CARRYING OUT ANY OPERATION

When carrying out removal or installation (disassembly or assembly) of units, be sure to follow the general precautions given below when carrying out the operation.

Precautions when carrying out removal work

- If the coolant contains antifreeze, dispose of it correctly.
- After disconnecting hoses or tubes, cover them or fit plugs to prevent dirt or dust from entering.
- When draining oil, prepare a container of adequate size to catch the oil.
- Confirm the match marks showing the installation position, and make match marks in the necessary places before removal to prevent any mistake when assembling.
- To prevent any excessive force from being applied to the wiring, always hold the connectors when disconnecting the connectors. Do not pull the wires.
- Fit wires and hoses with tags to show their installation position to prevent any mistake when installing.
- Check the number and thickness of the shims, and keep in a safe place.
- When raising components, be sure to use lifting equipment of ample strength.
- When using forcing screws to remove any components, tighten the forcing screws uniformly in turn.
- Before removing any unit, clean the surrounding area and fit a cover to prevent any dust or dirt from entering after removal.
- After disconnecting any piping during disassembly operations make sure to use the correct plugs and seals when connecting the piping again.

Precautions when carrying out installation work

- Tighten all bolts and nuts (sleeve nuts) to the specified torque.
- Install the hoses without twisting or interference and fix them with intermediate clamps, if there are any.
- Replace all gaskets, O-rings, cotter pins, and lock plates with new parts.
- Bend the cotter pins and lock plates securely.
- When coating with adhesive, clean the part and remove all oil and grease, then coat the threaded portion with 2 – 3 drops of adhesive.
- When coating with gasket sealant, clean the surface and remove all oil and grease, check that there is no dirt or damage, then coat uniformly with gasket sealant.
- Clean all parts, and correct any damage, dents, burrs, or rust.
- Coat rotating parts and sliding parts with engine oil.
- When press fitting parts, coat the surface with anti-friction compound (LM-P).

Continue reading on the next page

Legend for illustration Z 22192a

- (B4) Hydraulic oil level switch, level too low
- (B24) Low pressure switch, hydraulic tank breather filter monitoring. Switch point 0.08 bar (negative pressure).
- (B25) Pressure switch, leakage oil filter monitoring. Switch point 0.5 bar.
- (B26) Pressure switch, return oil filter monitoring. Switch point 2.0 bar.
- (B32) Temperature transmitter (analogue) hydraulic oil temperature.
- (B40) Temperature sensor, hydraulic oil cooler fan speed minimal (oil cool)
- (B42) Oil level switch, refilling system maximum filling (lamp H52).
- (B46) End line pressure switch, swing ring lubrication system.
- (B50) Oil level switch, refill level.
- (B75) Temperature sensor, low hydraulic oil temperature. Causes pump derate to 1/2 Q_{max}, reduction of the return oil back pressure through Y101 and fade out of the auxiliary filter monitoring.
- (B171) Not shown. Temperature sensor, hydraulic oil cooler fan speed medium (oil temperature medium). Option for low temperature versions only.
- (S31) Proximity switch at the main gate valve monitors valve position. Closed gate valve causing start prevention or shutdown and generates a warning message.
- (Y101) Solenoid valve for reducing the return oil back pressure (B75 controlled).
- (H47) Light at the access ladder.
- (H47a) Light at the cabin entrance and steps.
- (H48) Working light cabin, old with front lights.
- (H48A) Working light cabin, old with front lights.
- (H49) Service light in front of the control blocks.
- (H49A) Service light in front of the control blocks.
- (H50) Working light, on top of the oil cooler frame.
- (H50A) Working light, on top of the oil cooler frame.

Engine related parts	Engine oil pressure switch low idle [N.O. type]	B1	Measure voltage	If the condition is within the range shown in the table below, it is normal.		<ol style="list-style-type: none"> 1) S1 OFF 2) Disconnect connector 3) Insert T-box 4) S1 ON 5) Open disconnect-terminals 1 & 2 at the T-box 6) Engine low idle
				Between (1) - (2)	0V	
					<ol style="list-style-type: none"> 7) shutdown 	
					<ol style="list-style-type: none"> 7) shutdown 	
	Engine oil pressure switch high idle [N.O. type]	B30	Measure voltage	If the condition is within the range shown in the table below, it is normal.		<ol style="list-style-type: none"> 1) S1 OFF 2) Disconnect connector 3) Insert T-box 4) S1 ON 5) Open disconnect-terminals 1 & 2 at the T-box 6) Engine high idle
				Between (1) - (2)	0V	
					<ol style="list-style-type: none"> 7) shutdown 	
					<ol style="list-style-type: none"> 7) shutdown 	
	Coolant temperature sensor (PT100 type)	B2	Measure resistance	If the condition is within the range shown in the table below, it is normal.		<ol style="list-style-type: none"> 1) S1 OFF 2) Disconnect connector 3) Insert T-box
				Between (1) - (2)	Refer to PT100 temperature charts	
				<ol style="list-style-type: none"> 7) shutdown 		
				<ol style="list-style-type: none"> 7) shutdown 		
Coolant pressure switch high idle [N.O. type]	B41	Measure voltage	If the condition is within the range shown in the table below, it is normal.		<ol style="list-style-type: none"> 1) S1 OFF 2) Disconnect connector 3) Insert T-box 4) S1 ON 5) Open disconnect-terminals 1 & 2 at the T-box 6) Engine high idle 	
			Between (1) - (2)	0V		
				<ol style="list-style-type: none"> 7) Low idle 		
				<ol style="list-style-type: none"> 7) Low idle 		
Fuel level sensor (pressure sensor)	B63	Measure voltage	If the condition is within the range shown in the table below, it is normal.		<ol style="list-style-type: none"> 1) S1 OFF 2) Disconnect connector 3) Insert T-box 4) S1 ON 5) Open terminals 1 & 2 at T-box 6) Engine OFF 	
			Between B (1) - A (3) Between A (2) - C (3)	22 - 24V 0.8 - 1.0V		

Message -1- Gear lubrication out of function (PTO)**[2/3]**

Possible cause	Step	Test condition & Inspection	Procedure	Nominal value
Disconnection in the signal wiring between pressure switch B17 and Input signal module E39 (slave) of ETM version -A- or Input signal module E34 (CAN-node) of ETM version -B-.	4	▶ Main key switch S1 in the ON position.		
		ETM version -A- Check the input signal at the Input signal module E39 (slave) pin 1. ETM version -B- Check the input signal at the Input signal module E34 (CAN-node) pin 81. Is the signal present?	Yes The signal wiring between pressure switch B17 and Input signal module is OK. Go to next step.	No Disconnection, short circuit, or fault in the wiring (including connectors and pins) between pressure switch B17 and Input signal module. If necessary, check the segments of the signal wiring separately, locate the problem, and repair as necessary.
Adjustment of PTO valve block incorrect	5	Refer to the Service Manual section 2 -PTO LUBRICATION AND COOLING- and follow the given adjustment procedures. Are the pressure adjustments as specified?	Yes Go to next step.	
			No Carry out adjustments as necessary. After that recheck if the PTO gear lubrication pressure is in normal range.	
Setting of temperature switch unit K182 for oil cooler relief incorrect.	6	Check the PTO gear oil settings (viscosity) according to the table below. Are the oil settings correct?	Yes Recheck pressure switch B17 for continuity and rectify as necessary.	
			No Adjust K182 to the correct switching point and verify that trouble message 1 -Gear lubrication out of function- is not set again.	
Final check	7	Bring the machine back into the original condition. Start the machine and verify that the trouble code does not arise again.		

Adjust switch unit K182 to the respective oil viscosity grade as follows:

Oil viscosity grade according to ISO	HLP T32	CLP 150	SAE 80W-90
-K182- Adjust temperature limit value to switching point °C	+15°	+48°	+54°

Message -6- Leak oil filter restricted

[2/3]

Possible cause	Step	Test condition & Inspection	Procedure	Nominal value	
Defective pressure switch B25	4	Check Pressure switch B25 according to the Standard value table in this section. Is the test result OK?	Yes	Go to next step.	
			No	Replace pressure switch. After that recheck that the trouble condition does no longer exist.	
Incorrect or no supply voltage at the pressure switch B25	5	► Start engine and run at high idle.			
		Using the T-box, measure the supply voltage for B25 at the connector terminal 1. Is the correct supply voltage present?	Yes	Go to step 7.	V_{\min} 22V
			No	Go to next step.	V_{\max} 24V
Disconnection in the voltage supply wiring between circuit breaker F15 and pressure switch B25. (disconnection or defective contact in any connector)	6	► Engine stopped and main key switch S1 in OFF position.			
		Refer to the wiring diagram. Using the T-box, check the voltage supply wiring segments between the pressure switch B25 and circuit breaker F15 for continuity. Is continuity present?	Yes	Go to next step.	
			No	Disconnection, short circuit, or fault in the wiring between connector X67/7 and circuit breaker F15. If necessary, check the segments of the voltage supply wiring separately, locate the problem, and repair as necessary.	
Disconnection in the signal wiring between pressure switch B25 and Input signal module E39 (slave) of ETM version -A- or Input signal module E34 (CAN-node) of ETM version -B-.	7	► Main key switch S1 in the ON position.			
		ETM version -A- Check the input signal at the Input signal module E39 (slave) pin 6. ETM version -B- Check the input signal at the Input signal module E34 (CAN-node) pin 76. Is the signal present?	Yes	The signal wiring between pressure switch B24 and Input signal module is OK.	
			No	Disconnection, short circuit, or fault in the wiring (including connectors and pins) between pressure switch B25 and Input signal module. If necessary, check the segments of the signal wiring separately, locate the problem, and repair as necessary.	
Final check	8	Bring the machine back into the original condition. Start the machine and verify that the trouble message does not arise again.			

Message -10- Engine shutdown: too low engine oil pressure

[2/5]

Possible cause	Step	Test condition & Inspection	Procedure	Nominal value	
Malfunction of interacting relays in the wiring loop.	3	► Engine stopped and main key switch S1 in ON position.			
		Check the relevant relays in the wiring loop for proper functioning. Refer to the illustrations on page [3/5, 4/5 and 5/5] for typical configuration of the controlling relays. Use the applying electrical diagram and the Service Manual of your machine for the checking procedure. Are the relays in proper working order?	Yes	Go to next step.	
			No	Replace defective relays. Verify that trouble message 10 - Too low engine oil pressure- is not set again. Go to final step 5.	
Full flow oil filters plugged or components of the engine lubricating system (oil pressure regulator, pressure relief valve, lubricating oil pump) malfunction.	4	Contact the engine manufacturer's service staff for support.	Repair or replace defective parts as necessary. Verify that trouble message 10 - Too low engine oil pressure- is not set again. Go to final step 5.		
Final check	5	Bring the machine back into the original condition. Start the machine and verify that the trouble message does not arise again.			

Message -16- Caution, travel gear house brake ON**[2/5]**

Possible cause	Step	Test condition & Inspection	Procedure	Nominal value	
Disconnection in the signal wiring between pressure switch B48 and Input signal module E39 (slave) of ETM version -A- or Input signal module E34 (CAN-node) of ETM version -B-.	3	▶ Main key switch S1 in the ON position.			
		ETM version -A- Check the input signal at the Input signal module E39 (slave) pin 16. ETM version -B- Check the input signal at the Input signal module E34 (CAN-node) pin 66. Is the signal present?	Yes	The signal wiring between pressure switch B24 and Input signal module is OK.	
			No	Disconnection, short circuit, or fault in the wiring (including connectors and pins) between pressure switch B25 and Input signal module. If necessary, check the segments of the signal wiring separately, locate the problem, and repair as necessary.	
Defective ground connection at the pressure switch B48	4	▶ Prepare with the main key switch S1 in OFF position, and then carry out troubleshooting with the main key switch S1 in ON position.			
		Disconnect the cable connector X61F and check for proper ground connection at the connector terminal 2. Is the ground connection OK?	Yes	Go to next step.	
Defective pressure switch B48 (switch does not close)	5	▶ Prepare with the main key switch S1 in OFF position, and then carry out troubleshooting with the main key switch S1 in ON position.			
		Disconnect connectors X61E and X61F. Measure the continuity of the pressure switch B48 between the connector pins 1 and 2. Is continuity present?	Yes	Go to next step.	$R_{\max} 1\Omega$
The travel parking brake does not release even the engine is running	6	▶ Keep the engine running at high idle.			
		Check if battery voltage (approx. 24 V) is present at terminal 8 of relay K3. Is battery voltage (approx. 24 V) present?	Yes	Go to next step.	$V_{\min} 22V$ $V_{\max} 24V$
			No	Check if supply voltage is present at circuit breaker F21. Check the relay K3 and its wiring. Repair or replace as necessary.	

Message -19- Slew ring lubrication system fault**[3/8]**

Possible cause	Step	Test condition & Inspection	Procedure	Nominal value
Disconnection in the voltage supply wiring between circuit breaker F21 and pressure switch B47. (disconnection or defective contact in any connector)	11	► Engine stopped and main key switch S1 in OFF position.		
		Refer to the wiring diagram. Using the T-box, check the voltage supply wiring segments between the pressure switch B47 and circuit breaker F21 for continuity. Is continuity present?	Yes Go to next step. No Disconnection, short circuit, or fault in the wiring between connector X69/1 and circuit breaker F21. If necessary, check the segments of the voltage supply wiring separately, locate the problem, and repair as necessary.	
No lubrication during the last 4.2 working hours. Bucket movement disabled due to malfunction of relay K50.	12	► Keep the main key switch S1 in the ON position.		
		Check the function of relay K50 in the X2 switch box. - K50 active (24 V): Bucket movement enabled, LED ON. - K50 inactive (0 V): Bucket movement disabled Does the function of relay K50 meet the above specification?	Yes Go to next step. No Replace relay K50 and check for proper system function. If the problem is not yet rectified go to next step.	
Malfunction or damage in the wiring circuit of relay K50	13	Refer to the wiring diagram on page [8/8]: - Check if B+ voltage is present - Check for proper ground connection - Check the wiring for continuity Is any problem diagnosable in the wiring circuit of relay K50?	Yes Repair the wiring or replace any defective electrical component as necessary. Go to final step 14. No Check if any other fault message is set which may be in cross-correlation with the existing problem. If so, follow the applying troubleshooting chart and after that recheck for proper system function.	
Final check	14	Bring the machine back into the original condition. Start the machine and verify that the fault message does not arise again. Verify that the operation cycles of the lubrication system correspond to the diagram shown on next page.		

CLICK HERE TO **DOWNLOAD** THE COMPLETE MANUAL

- Thank you very much for reading the preview of the manual.
- You can download the complete manual from: www.heydownloads.com by clicking the link below



- Please note: If there is no response to CLICKING the link, please download this PDF first and then click on it.

CLICK HERE TO **DOWNLOAD** THE COMPLETE MANUAL

Circuit diagram related to message -21- and -22-

[6/6]

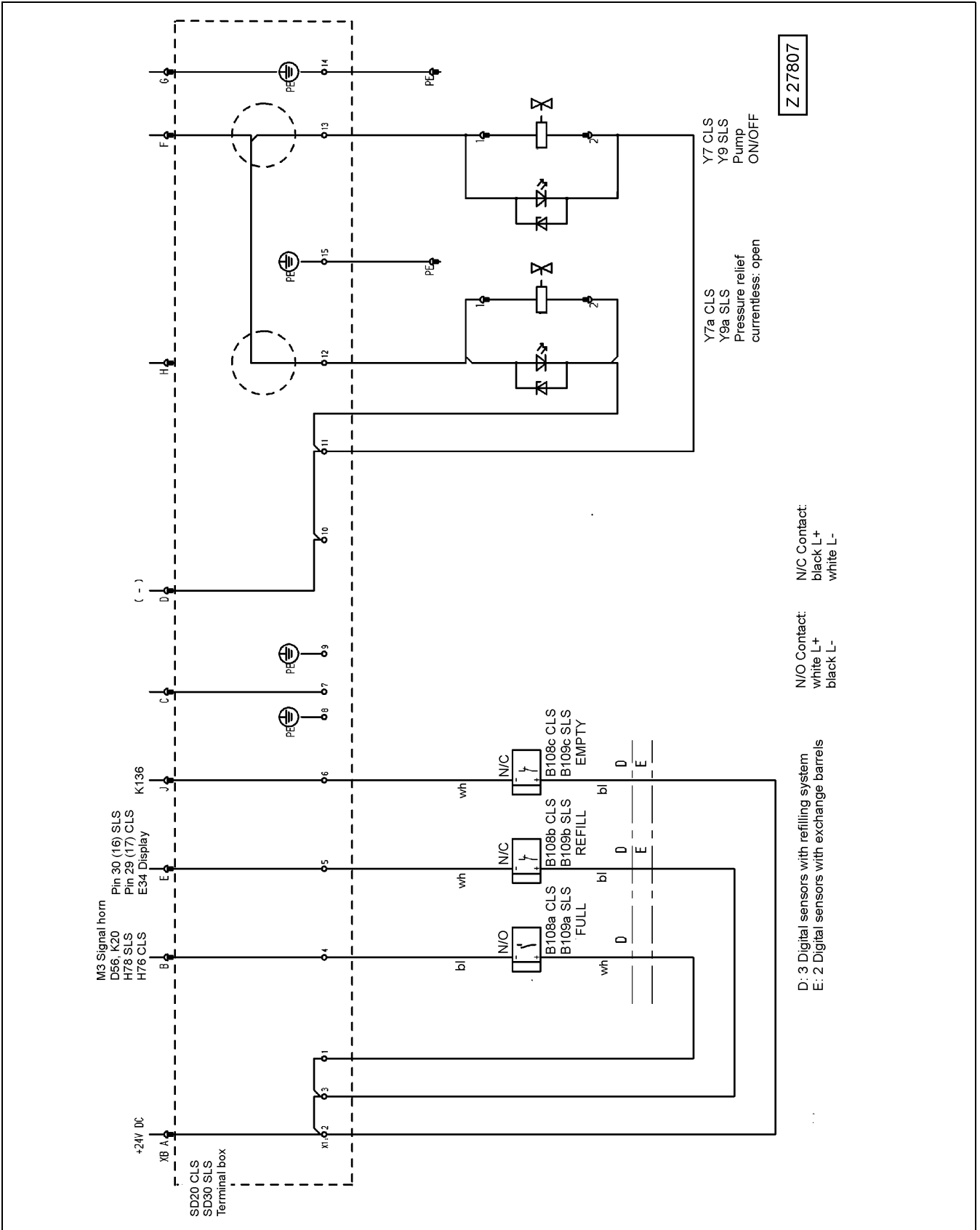

Z 27807

Illustrations related to trouble message -39-

[3/4]

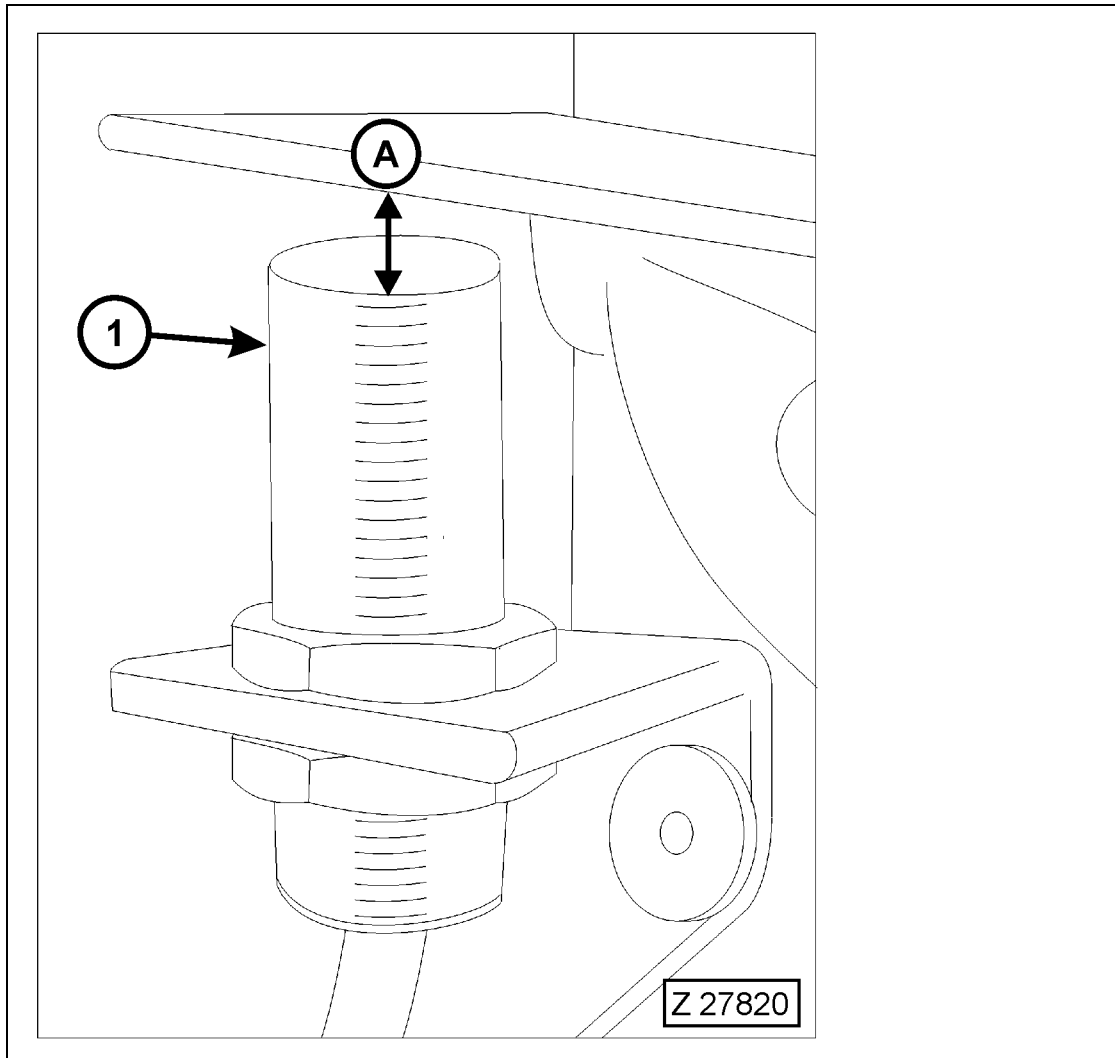
**Legend for illustration Z27820**

(1) Proximity switch S31

(A) Gap: 3 - 5 mm

Circuit diagram related to trouble message -44-

[4/4]

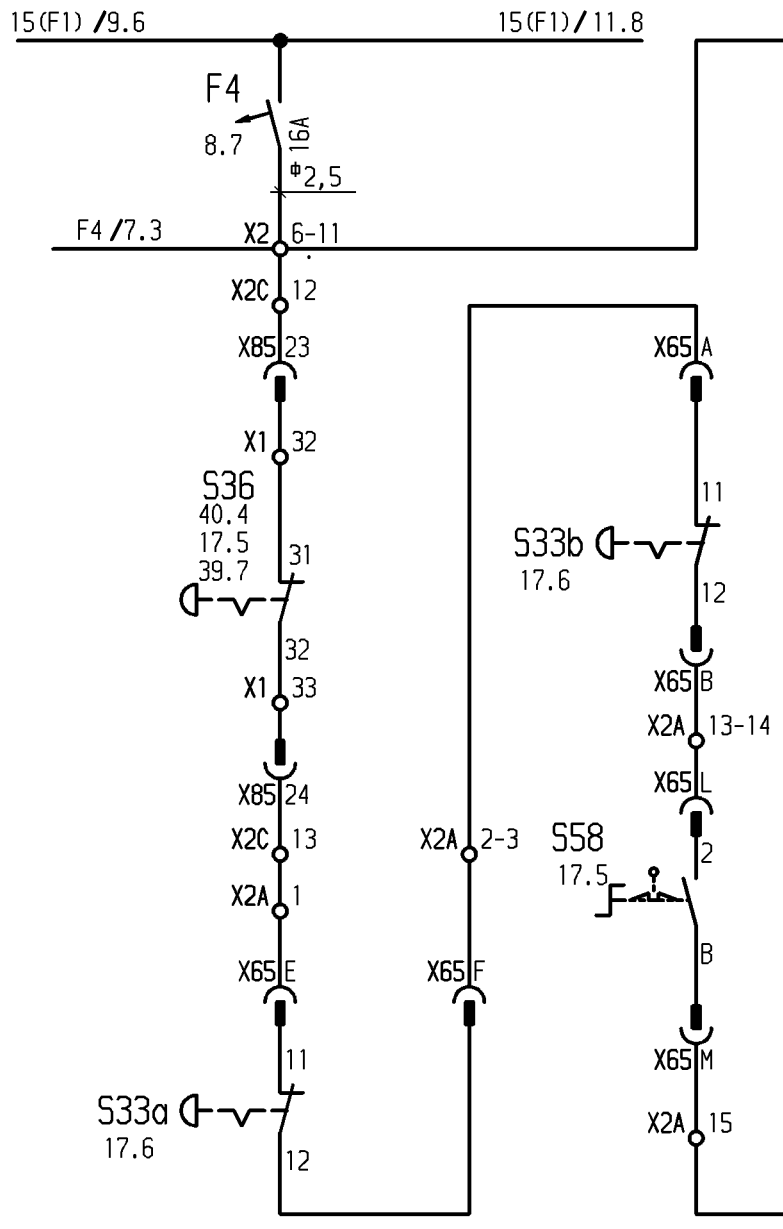

Z 27829

MESSAGE -55- REFILL HYDRAULIC OIL

[1/4]

Trouble code	Trouble	Refill hydraulic oil
Message page 55		
Contents of trouble	<ul style="list-style-type: none"> Sensor B50 indicates that the hydraulic oil level is below the normal operating range. 	
Related information	<ul style="list-style-type: none"> If the sensor B50 does not sense oil, its signal voltage turns to 0 V. A problem with the sensor or connected wiring may also cause the trouble, see table [2/4] for testing procedure of the signal wiring and connections. For more information see also the illustrations on page [3/4 and 4/4]. 	
Problem that appears on machine	<ul style="list-style-type: none"> Risk to run out of hydraulic oil 	

Possible cause	Step	Test condition & Inspection	Procedure	Nominal value
The hydraulic oil level is below the normal operating level	1	<ul style="list-style-type: none"> Check with stopped engine and the attachment in its defined position. 		
		Verify if the hydraulic oil level in the main oil reservoir is above or below the oil level sensor B50, see illustration Z27888 on page 3 of this chart. Refer also to illustration Z28000 on page 4 of this troubleshooting chart, which shows the hydraulic oil tank label with the defined positions at the bottom of the label and the relevant oil levels on the left and right side of the label. Is the oil level below the sensor B50?	Yes Refill specified hydraulic oil and verify that trouble message 55 is not displayed again.	
Incorrect or no supply voltage in the circuit of the oil level sensor B50	2	<ul style="list-style-type: none"> Prepare with the main key switch S1 in OFF position, and then carry out troubleshooting with the main key switch S1 in ON position. 		
		Disconnect the cable connector from the oil level sensor B50, insert the T-box, and measure the supply voltage at the cable connector terminal A. Is supply voltage present?	Yes Go to step 5.	V_{min} 22V V_{max} 24V
	3	Check if supply voltage is present at the power supply line F12. Is supply voltage present?	No Go to next step.	
			Yes Go to step 4.	V_{min} 22V V_{max} 24V
		No Disconnection or short circuit in any wire segment (including connectors) between sensor B50 and the main power supply from F1. Locate the problem and repair as necessary		

TROUBLESHOOTING BY SYMPTOMS

SEL007 - Oil becomes contaminated quickly

[2/2]

Judgment Table

		Causes							
		Worn piston ring, cylinder liner	Clogged breather or breather hose	Clogged oil filter	Worn valve, valve guide	Clogged turbocharger drain pipe	Defective seal at turbocharger turbine end	Defective safety valve	Exhaust smoke is black
Questions	Confirm the recent repair history								
	Degree of use of the machine	Operated for a long period	◇			◇		◇	
	Engine oil must be added more frequently		■						
	Non-specified engine oil is used			○					
Check items	Colour of exhaust gas	Blue under light load	■						
		Black							■
	Amount of blow-by gas	Excessive	■			○	○	○	
		None		■					
		When the filter is inspected, metal particles are found	○		■	○			
		When exhaust pipe is removed, the inside is dirty with oil				■			
	Engine oil temperature rises quickly					■			
Troubleshooting	Measured compression pressure it is too low		●			●			
	When the breather element is checked, hose is broken or it is clogged with dirty oil			●					
	When the oil filter is inspected, it is found to be clogged				●				
	Turbocharger drain tube is clogged						●		
	Excessive play at the turbocharger shaft							●	
	When the safety valve is inspected, the spring is found to be catching or broken								●
	Remedy	Replace	Clean	Replace	Replace	Clean	Replace	Replace	Follow troubleshooting for: Exhaust

SHY006 - MACHINE DEVIATES DURING TRAVEL MOVEMENT

[1/1]

Trouble code	Trouble	Machine deviates during travel movement
SHY006		
Contents of trouble	<ul style="list-style-type: none"> • During machine traveling the shovel deviates to one side. • The shovel is traveling only (no other movement is done). • Precondition: flat ground and same grip on both sides. 	
Related information	<ul style="list-style-type: none"> • The PM-CLINIC procedures were performed successfully. • The SRV and MRV adjustments meet the nominal values of the hydraulic diagram. • The left and right track wear measurement is on the same level. 	
Problem that appears on machine	<ul style="list-style-type: none"> • During machine traveling the shovel deviates to one side. • The operator has to stop the shovel after a couple of meters in order to correct the direction of travel to straight forward. 	
Possible causes	<ul style="list-style-type: none"> • Defective hydraulic travel motor. • Internal leak in the rotary joint. 	

Possible cause	Step	Test condition & Inspection	Procedure	Nominal value	
Defective hydraulic travel motor Internal leak in the rotary joint	1	► Keep the engine running at high idle.			
		Connect high pressure gauges (400 bar) to the main blocks. Disconnect the parking brake solenoid Y16 in order to close the brake. Actuate the travel pedals and read the current pressure at the gauges. Is there any pressure difference between left and right, or loss of pressure?	Yes	Disconnect the ports A and B at the travel motors (in order to exclude the travel motors). Plug the hoses and the inlet ports of the travel motors. Now check the pressure again. If the pressure values are still the same as before, replace the travel motor(s).	SRV: 310 bar MRV: 315 bar
			No	If the pressure values are not the same as before, repair or replace the rotary joint due to an internal leakage.	
Final check	2	Bring the machine back into the original condition. Start the machine and verify that the repair was successful.			

SHY017 - SWING PARKING BRAKE WITHOUT FUNCTION

[1/1]

Trouble code	Trouble	Swing parking brake without function
SHY017		
Contents of trouble	<ul style="list-style-type: none"> The swing parking brake is inoperative (the superstructure moves) although the swing parking brake switch S29 is switched to position 1 (brake closed). The X2 pressure circuit is already tested and ok (X2 pressure 35 bar at valve Y5). The electrical circuit is already tested and ok. 	
Related information	<ul style="list-style-type: none"> The swing parking brake is a disc brake, mounted on the top of the swing gearbox. The -Siebenhaar- swing gearbox has an external swing brake housing with a separate oil filling. The -L&S- swing gearbox has an integrated swing brake system which is lubricated by the gearbox oil. Both swing parking brakes are working as a -Spring Loaded System-. That means the pilot pressure opens the swing parking brakes. Without pilot pressure the springs close the swing parking brakes. 	
Problem that appears on machine	<ul style="list-style-type: none"> The swing parking brake is inoperative. 	
Possible causes	<ul style="list-style-type: none"> The pilot pressure in the swing parking brake circuit is not released. The brake discs are burnt and/or the piston seals are defective. 	

Possible cause	Step	Test condition & Inspection	Procedure	Nominal value	
The pilot pressure in the swing parking brake circuit is not released	1	► Main key switch S1 in OFF position & maintenance safety switch S58 locked.			
		The solenoid valve Y5 is mechanically stuck. The pilot pressure in the swing parking brake line is not released to the hydraulic oil tank. Is the piston of the solenoid valve stuck?	Yes	Replace the solenoid valve Y5.	
			No	Go to next step.	
The brake discs are burnt and the piston seals are defective	2	► Main key switch S1 in OFF position & maintenance safety switch S58 locked.			
		Perform the following steps: <ul style="list-style-type: none"> Disconnect the pilot pressure supply hoses for the swing parking brakes from the swing gearbox. Install a manual hydraulic pump with 60 bar manometer in order to test the swing parking brake piston seals. Use a manual pump and increase the pressure up to 35 bar. The built-up pressure must be held for 15 minutes. Can you build-up and hold the pressure for 15 minutes?	Yes	Check for leaks or mixed-up connections in the pilot supply lines for the swing parking brake system.	35 bar for 15 minutes
			No	Repair or replace the swing parking brake and check the swing parking brake for proper operation.	
Final check	3	Bring the machine back into the original condition. Start the machine and verify that the repair was successful.			

SME008 - Abnormal noise coming from the work equipment (lack of grease)**[2/2]**

Possible cause	Step	Test condition & Inspection	Procedure	Nominal value
Contaminated grease is used (grease barrel refilling without refilling the filter)	2	► Main key switch S1 OFF & maintenance safety switch S58 locked.		
		The injectors are worn out due to contaminated grease in the barrel. No or not enough grease causes early wear and noise at the pins and bushings of the attachment. Are pins and bushings worn out due to lacking grease and defective injectors?	Yes	Replace the contaminated grease by specified grease. Clean or replace the barrel as necessary. Replace the defective pins and bushings on the attachment side. Check all grease injectors for proper function. Pre-lubricate all pins and bushings through the injectors until the new grease flows out.
		No	Go to next step.	
Daily fault messages of the CLS system occur. Download the data from the protocol memory of the ETM and verify the system status	3	► Keep the main key switch S1 in ON position.		
		Download the data from the protocol memory of the ETM and verify the system status. Do the memory data show a lot of -bucket cut off- messages due to missing grease?		Repair or replace any defective parts of the CLS system as necessary. Replace the defective pins and bushings on the attachment side (standardization as primary state). Check all grease injectors for proper function. Pre-lubricate all pins and bushings through the injectors until the new grease flows out.
Final check	4	Bring the machine back into the original condition. Start the machine and verify that the repair was successful.		

3.6.3	PILOT OIL PUMP (GEAR PUMP)	3-97
3.6.3.1	REMOVAL OF THE PILOT OIL PUMP	3-98
3.6.3.2	REPLACEMENT OF THE PILOT OIL PUMP	3-100
3.6.4	MAIN GATE VALVE	3-101
3.6.4.1	REMOVAL OF THE MAIN GATE VALVE	3-101
3.6.4.2	REPLACEMENT OF THE MAIN GATE VALVE	3-103
3.6.5	HYDRAULIC OIL RESERVOIR	3-104
3.6.5.1	REMOVAL OF THE HYDRAULIC OIL RESERVOIR	3-106
3.6.5.2	REPLACEMENT OF THE HYDRAULIC OIL RESERVOIR	3-111
3.6.6	MAIN CONTROL VALVE BLOCKS	3-114
3.6.6.1	GENERAL INFORMATION	3-114
3.6.6.2	REMOVAL OF THE MAIN CONTROL VALVE BLOCKS	3-124
3.6.6.3	REPLACEMENT OF THE MAIN CONTROL VALVE BLOCKS	3-129
3.6.7	MAIN RELIEF VALVES (MRV)	3-130
3.6.7.1	REMOVAL OF THE MRV AT THE MAIN CONTROL VALVE BLOCKS	3-130
3.6.7.2	REPLACEMENT OF THE MRV AT THE MAIN CONTROL VALVE BLOCKS ..	3-131
3.6.8	SERVICE LINE RELIEF VALVES (SRV)	3-132
3.6.8.1	REMOVAL OF SRV ON THE MAIN CONTROL VALVE BLOCKS	3-132
3.6.8.2	REPLACEMENT OF SRV ON THE MAIN CONTROL VALVE BLOCKS	3-134
3.6.9	ANTI-CAVITATION VALVES (ACV)	3-135
3.6.9.1	REMOVAL OF ACV ON MANIFOLD	3-136
3.6.9.2	REPLACEMENT OF ACV ON MANIFOLD	3-138
3.6.9.3	REMOVAL OF ACV ON MAIN CONTROL VALVE BLOCKS	3-139
3.6.9.4	REPLACEMENT OF ACV ON MAIN CONTROL VALVE BLOCKS	3-141
3.6.10	THROTTLE CHECK VALVES	3-142
3.6.10.1	REMOVAL OF THROTTLE CHECK VALVES	3-144
3.6.10.2	REPLACEMENT OF THROTTLE CHECK VALVES	3-147
3.6.10.3	REMOVAL OF THE DIFFUSER ON THE MANIFOLD (FSA ONLY)	3-148
3.6.10.4	REPLACEMENT OF THE DIFFUSER ON THE MANIFOLD (FSA ONLY)	3-150
3.6.11	MANIFOLD	3-152
3.6.11.1	LAYOUT	3-152
3.6.11.2	REMOVAL OF THE MANIFOLD	3-154
3.6.11.3	REPLACEMENT OF THE MANIFOLD	3-156
3.7	SLEW DRIVE	3-157
3.7.1	SLEW GEAR BOX	3-158
3.7.1.1	REMOVAL OF THE SLEW GEAR BOX	3-159
3.7.1.2	REPLACEMENT OF THE SLEW GEAR BOX	3-162
3.7.2	SWING MOTOR	3-166
3.7.2.1	REMOVAL OF THE SWING MOTOR	3-167
3.7.2.2	REPLACEMENT OF THE SWING MOTOR	3-170
3.7.3	SLEW PARKING BRAKE	3-172
3.7.3.1	REMOVAL/DISASSEMBLY OF THE SLEW PARKING BRAKE (L&S)	3-174
3.7.3.2	REPLACEMENT/ASSEMBLY OF THE SLEW PARKING BRAKE (L&S)	3-177
3.7.3.3	REMOVAL OF THE SLEW PARKING BRAKE (SIEBENHAAR)	3-179
3.7.3.4	REPLACEMENT OF THE SLEW PARKING BRAKE (SIEBENHAAR)	3-182
3.7.4	DYNAMIC SLEW BRAKE	3-185
3.7.4.1	REMOVAL OF THE SLEW SERVICE BRAKE VALVE	3-188
3.7.4.2	REPLACEMENT OF THE SLEW SERVICE BRAKE VALVE	3-190

All PARTS & SERVICE NEWS which are mentioned in the procedures are listed in chapter 8. The numbers of the PARTS & SERVICE NEWS do not label the latest edition. Ensure that the latest edition is always filed to the binder of this manual.

- The following symbols and designations are used in the manual to designate instructions of particular importance:

▲ DANGER

Refers to orders and prohibitions designed to prevent serious injury or death.

▲ WARNING

Refers to orders and prohibitions designed to prevent injury or extensive damage.

▲ CAUTION

Refers to special information and/or orders and prohibitions directed towards preventing damage.

NOTE: Refers to special information on removing or installing assemblies, for example if any special technique needs to be applied.

Fall protection systems have to be treated with care and to be kept clean and ready for use. It has to be warned against bringing the systems into contact with acids or other caustic liquids and gases, oils, detergents, or sharp-edged objects.

If the harness has become wet during use or cleaning, do not dry near a fire or other sources of heat, but rather in a natural way in not too warm rooms. Keep the harness freely suspended or loosely rolled up.

When using the fall protection systems, the pertaining safety regulations in force and the "Rules for Use of Personal Fall Arrest Systems" have to be observed for protection against danger.

▲ WARNING

At least every 12 months, the safety harness and its components have to be inspected by a competent person authorized by the manufacturer and they have to be maintained, if the manufacturer considers it to be necessary.

2.2.5.3 RECOMMENDATIONS FOR USE OF THE HOLDING HOOKS AND HOLD-BACK HOOKS OF THE SAFETY HARNESS

During the holding function, the connectors may only be placed around a mast or any other construction between the two holding hooks, so that the free fall is limited to max. 0.5 m.

It should be strictly seen to it that the connector is not slung around constructions with too small diameters or sharp edges.

With the lateral holding hooks, work may only be carried out on horizontal or almost horizontal surfaces (roofs). The connectors have to be adjusted in such a way that the area, where danger of falling down prevails, cannot be reached.

- Open the cable brackets (Fig. 3-4, Pos. 1) and clear all wiring harnesses (Fig. 3-4, Pos. 2) from the roof frame (Fig. 3-4, Pos. 5).

NOTE: Clear the wiring harnesses which are mounted at the roof frame from outside as well.

WARNING

Pay attention to the Fire Detection and Suppression System. Refer to the separate manuals "Fire Detection and Actuating System" and "Fire Suppression System"

The wires of the Fire Detection and Suppression System must not be bent excessively or be damaged to remain functional.

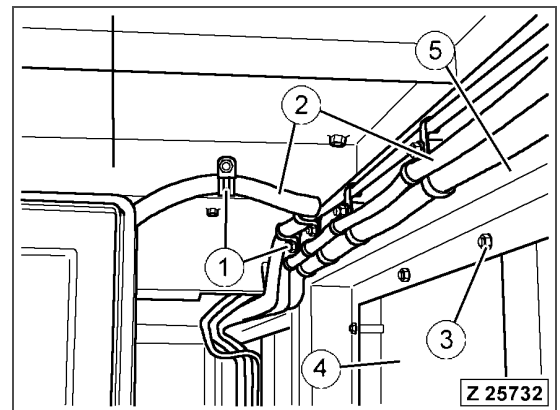

Fig. 3-4

- Remove nuts (Fig. 3-4, Pos. 3) and bolts at the top row of all wall plates (Fig. 3-4, Pos. 4) to clear the roof frame (Fig. 3-4, Pos. 5) from the walls of the engine housing.
- Remove the cover (Fig. 3-5, Pos. 1).

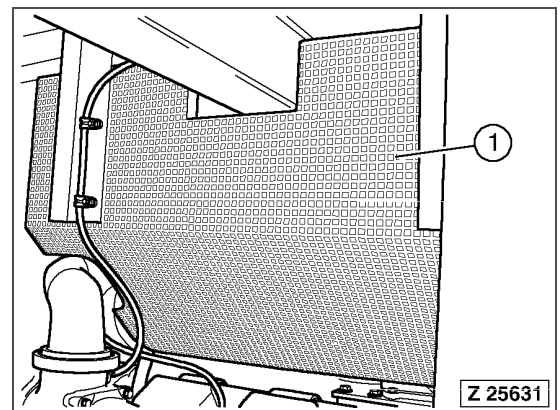

Fig. 3-5

- Remove the clamps (Fig. 3-6, Pos. 1) at the exhaust pipes and remove the flexible pipes (Fig. 3-6, Pos. 2) to both mufflers.
- Remove the clamps (Fig. 3-6, Pos. 3) of the intake hoses and remove the air intake pipes (Fig. 3-6, Pos. 4) from the intake manifolds.

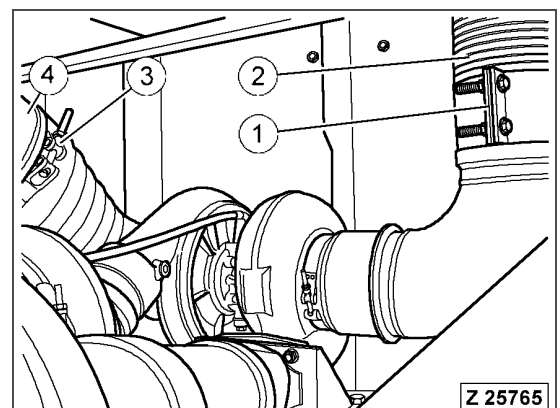

Fig. 3-6

- Remove the hand rails from the engine house roof.

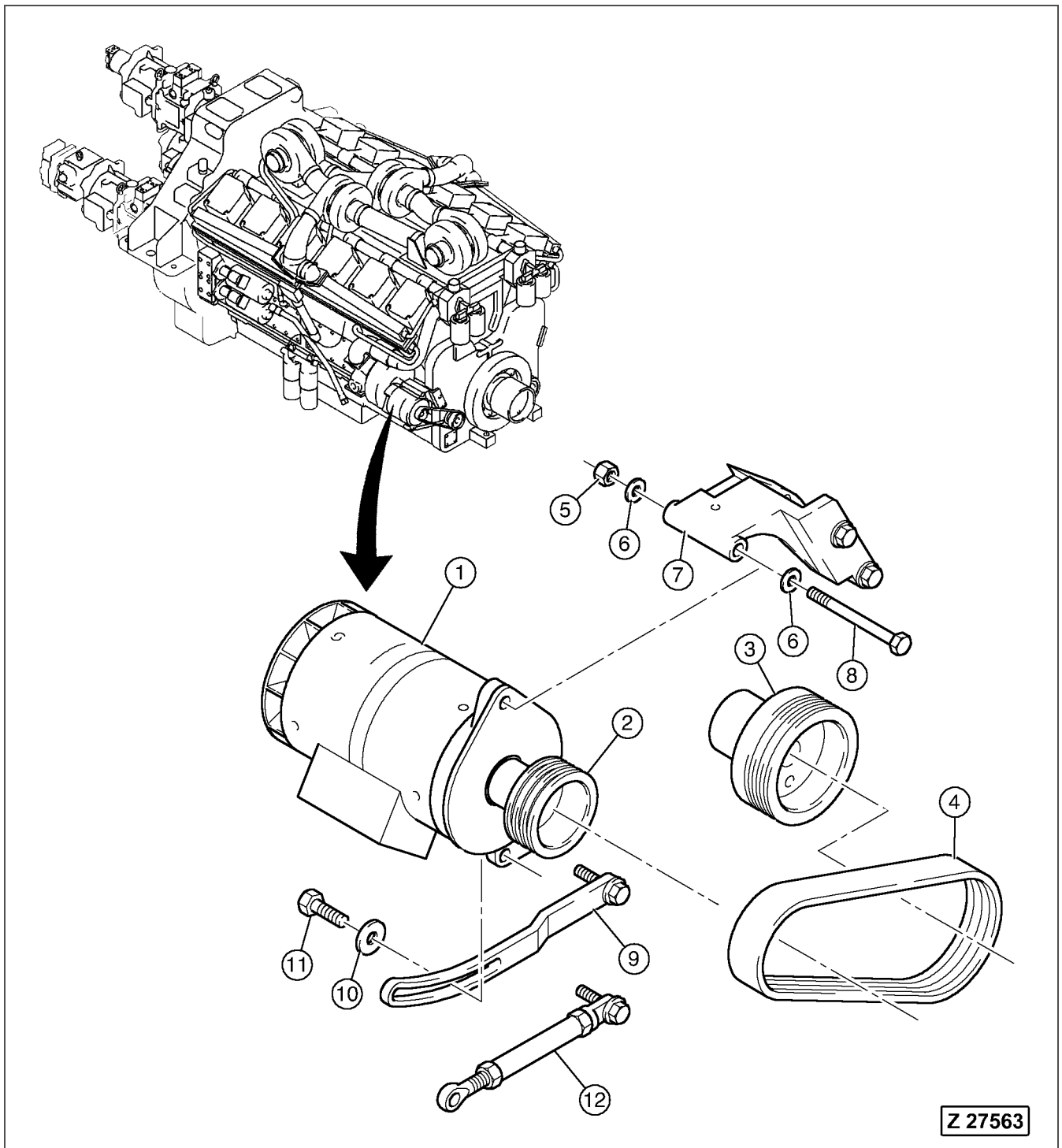





Fig. 3-19 Removal of alternator

- Loosen bolt (Fig. 3-19, Pos. 8).
- Remove bolt (Fig. 3-19, Pos. 11) and remove washer (Fig. 3-19, Pos. 10) from either the slotted bar (Fig. 3-19, Pos. 9) or the turn buckle (Fig. 3-19, Pos. 12).
- Remove the tension belt (Fig. 3-19, Pos. 4) from the pulleys (Fig. 3-19, Pos. 2 and 3).
- Remove bolt (Fig. 3-19, Pos. 8), nut (Fig. 3-19, Pos. 5), and washers (Fig. 3-19, Pos. 6) and remove the alternator.

3.3.8.2 REPLACEMENT OF THE STARTER MOTOR.

Special tools:	n/a
Additional equipment:	n/a
	Starter motor: 35 kg Starter motor with prelubrication pump: 43.5 kg
	Second person to remove the starter motor
	If there is nothing mentioned explicitly, tighten all bolts according to KOMATSU company standard, refer to section 6.5 on page 6-12.

- Carry out installation in reverse order to removal.

NOTE: A second person is required to install the starter motor.



Tightening torque for starter motor mounting bolts (multi-point): 215 Nm



- Check engine oil and refill to the specified level if required (starter with pre lubrication pump).

Refer to the Engine Operation & Maintenance Manual volume 2.

- Close the hand wheel (Fig. 3-46, Pos. 1) of main gate valve between suction oil reservoir and main oil reservoir.

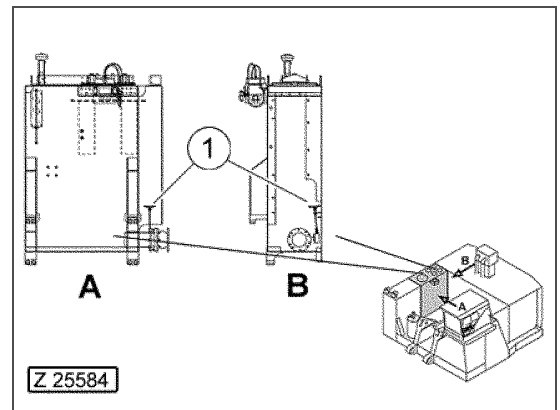

Fig. 3-46

- Open the cover (Fig. 3-47, Pos. 1) of the return oil filter.
- Transfuse oil from the suction oil reservoir into the main oil reservoir, refer to the PARTS & SERVICE NEWS No. "AH10530".

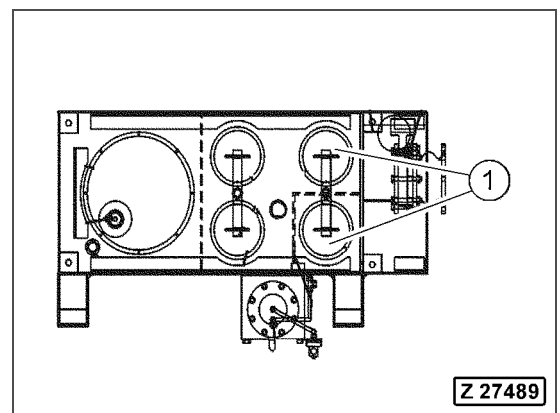

Fig. 3-47

- Remove the return oil hoses (Fig. 3-48, Pos. 1) on the main pumps to accelerate the draining of oil from the pump.

NOTE: The following steps indicate the standard procedure for main pump removal. It is also possible to access the main pump assemblies with a crane by opening the PVG sound silencer gate on the right side of the engine housing.

Carry out the following steps only if you refer to the standard procedure.

- Remove all cables which are fixed at the roof plates over the pumps or running through the plates.

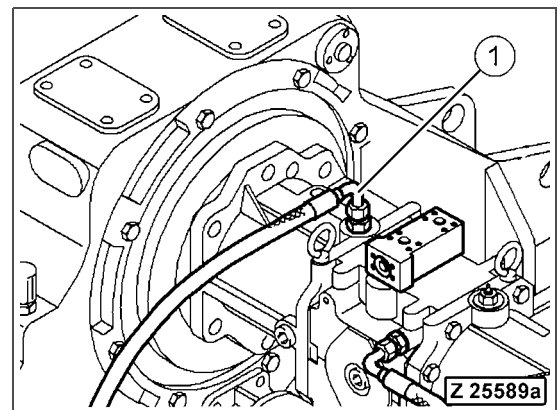





Fig. 3-48

WARNING

Pay attention to the Fire Detection and Suppression System. Refer to the separate manuals "Fire Detection and Actuating System" and "Fire Suppression System".

The wires of the Fire Detection and Suppression System must not be bent excessively or be damaged to remain functional.

3.5.1.7 REPLACEMENT OF MAIN PUMP 3

Special tools:	n/a
Additional equipment:	Crane Paste "Optimol White" PN 999 039
	Main pump 3 assembly: 481 kg
	Dogman/rigger
	If there is nothing mentioned explicitly, tighten all bolts according to KOMATSU company standard, refer to section 6.5 on page 6-12.

- Carry out installation in reverse order to removal.

NOTE: Always use new O-rings at the SAE-flange connections.

Use "Optimol White" on the spline shaft of the pump.



- Refill oil at the level plug (Fig. 3-66, Pos. 1) in the spline shaft housing.

For the proper lubricant, refer to the Operation & Maintenance Manual, chapter 4, section "FLUIDS AND LUBRICANTS".

Fill up to lower edge of level plug openings.

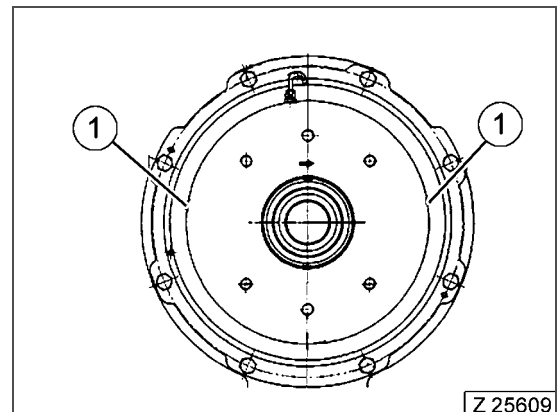

Fig. 3-66

- Open the main gate valve completely.
- Bleed air from the hydraulic system, refer to Operation & Maintenance Manual, chapter 4, section "HYDRAULIC SYSTEM - CHANGE OIL, REPLACE SUCTION STRAINERS AND PULSATION DAMPER" and to the PARTS & SERVICE NEWS No. "AH06519".

NOTE: To bleed air from the PTO oil circulation pump backfill the pump.

- Add hydraulic oil up to the specified level.
- Carry out the teaching procedure for main pump 3. Refer to the Service Manual.

Legend for Fig. 3-80:

- (1) Collector tube
- (2) Connection to distributor pipe
- (3) Connection to back pressure valve
- (4) Back pressure valve
- (5) Connection to return oil chamber (not cooled)
- (6) Pulsation damper
- (7) Distribution to each cooler (four)
- (8) Resistor close to inlet of the cooler
- (9) Cooler outlet
- (10) Cooled return oil to the reservoir
- (11) Connection to return oil chamber (cooled oil)
- (12) Screen filter (cooler protection)
- (13) Filter monitoring difference pressure switch
- (14) Oil cooler
- (15) Return oil filter chamber
- (16) Hydraulic oil reservoir
- (17) Distributor pipe

The return oil from the hydraulic system flows via hoses into the collector tube (Fig. 3-80, Pos. 1). One pair of hoses (Fig. 3-80, Pos. 3) connects the tube with the back pressure valve (Fig. 3-80, Pos. 4) at the return oil chamber of the hydraulic oil reservoir.

Another pipe connects the collector tube via a screen filter (Fig. 3-80, Pos. 12) to a distributor pipe and pulsation damper (Fig. 3-80, Pos. 6). This pulsation damper is for preventing damage of the oil cooler and pipes due to pressure peaks. A differential pressure switch (Fig. 3-80, Pos. 13) monitors the screen filter condition. Another two or four hoses (Fig. 3-80, Pos. 7) (depends on the number of cooler elements) connects the distributor pipe (Fig. 3-80, Pos. 17) to the oil cooler (Fig. 3-80, Pos. 14).

The back pressure valve (Fig. 3-80, Pos. 5) limits the return oil pressure, which is created by the oil flow through the restriction (Fig. 3-80, Pos. 8) in front of the cooler (Fig. 3-80, Pos. 14).

On the flow to the cooler the hydraulic oil pass, the restriction gets cooled in the cooler and then flows through the lines (Fig. 3-80, Pos. 10) into the filter chamber (Fig. 3-80, Pos. 15) of the hydraulic oil reservoir (Fig. 3-80, Pos. 16).

The restriction and the connected pulsation damper act as shock absorbers to prevent cooler cracks created from pressure peaks.



Besides the function to limit the back pressure, the valve (Fig. 3-80, Pos. 4) acts as an oil flow control valve if the oil temperature has not reached its minimum operation temperature.

⚠ WARNING

Always wear a Safety harness when working at the hydraulic oil coolers.

- Change the resistor closes (Fig. 3-80, Pos. 8) and all blind plugs from the old oil cooler to the new oil cooler.
- Apply glue PN 256 952 40 at the profiled joints (Fig. 3-91, Pos. 5 to 7) and attach the profiled joints to the oil cooler:
(Fig. 3-91, Pos. 5) 30 x 1600
(Fig. 3-91, Pos. 6) 25 x 1600
(Fig. 3-91, Pos. 7) 15 x 1600
- Carry out further installation in reverse order to removal.
- Open the main gate valve completely.
- Bleed air from the hydraulic system, refer to the Operation & Maintenance Manual, chapter 4, section "HYDRAULIC SYSTEM - CHANGE OIL, REPLACE SUCTION STRAINERS AND PULSATION DAMPER" and to the PARTS & SERVICE NEWS No. "AH06519".
- Add hydraulic oil up to the specified level.
- Add PTO gear oil to the specified level.

3.6.4.2 REPLACEMENT OF THE MAIN GATE VALVE

Special tools:	n/a
Additional equipment:	n/a
	Main gate valve: 22 kg
	If there is nothing mentioned explicitly, tighten all bolts according to KOMATSU company standard, refer to section 6.5 on page 6-12.

- Carry out installation in reverse order to removal.



- Fill hydraulic oil into the hydraulic oil reservoir, approx. 2900 liters.

Refer to the Operation & Maintenance Manual, chapter 4, section "HYDRAULIC SYSTEM - CHANGE OIL, REPLACE STRAINERS AND PULSATION DAMPER".

- Open the main gate valve completely.
- Bleed air from the hydraulic system, refer to Operation & Maintenance Manual, chapter 4, section "HYDRAULIC SYSTEM - CHANGE OIL, REPLACE SUCTION STRAINERS AND PULSATION DAMPER" and to the PARTS & SERVICE NEWS No. "AH06519".
- Add hydraulic oil up to the specified level.

Legend for Fig. 3-124:

Main control valve block 1

- (1) SRV (67), stick cylinder rod side
- (2) ACV (68.1), stick cylinder rod side
- (3) ACV (68.2), stick cylinder piston side
- (4) ACV (68.4), travel backward
- (5) ACV (68.3), travel forward
- (19) MRV block 1

Main control valve block 2

- (9) SRV (66.3), boom cylinder rod side
- (10) SRV (98), boom cylinder piston side
- (11) SRV (66.5), bucket cylinder rod side
- (12) SRV (66.4), bucket cylinder piston side
- (13) SRV (66.7), stick cylinder rod side
- (14) ACV (68.6) + SRV (66.6), stick cylinder piston side
- (15) ACV (68.8), travel backward
- (16) ACV (68.7), travel forward
- (20) MRV block 2

NOTE: The numbers in brackets behind the valve type (ACV/SRV) are component numbers for the hydraulic diagram.
Refer to the hydraulic diagram of the respective machine to identify the individual valves.
Fig. 3-124 shows a standard arrangement of BHA.

- Remove the MRV (Fig. 3-138, Pos. 1, 2 or 3) from the main control valve block.

NOTE: When the MRV is removed, oil will flow out of the main control valve block. Catch it in an oil pan.

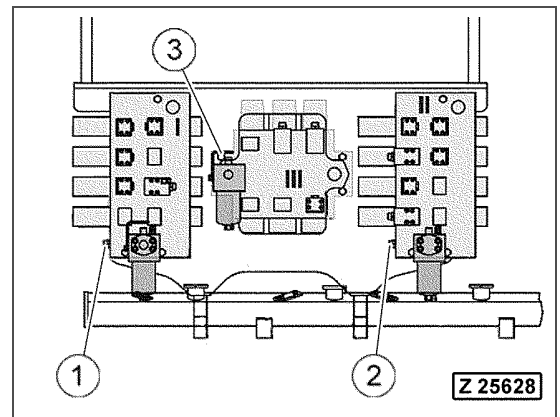

Fig. 3-138

3.6.7.2 REPLACEMENT OF THE MRV AT THE MAIN CONTROL VALVE BLOCKS

Special tools:	36 mm Socket wrench, PN 232 374 40
Additional equipment:	n/a

NOTE: Fit new O-rings to the MRV.

- Carry out installation in reverse order to removal.

NOTE: Tighten the MRV (Fig. 3-138, Pos. 1, 2 or 3) to the specified torque.



**Tightening torque for MRV:
300 Nm**

- Open the main gate valve completely.
- Bleed air from the hydraulic system, refer to the Operation & Maintenance Manual, chapter 4, section "HYDRAULIC SYSTEM - CHANGE OIL, REPLACE SUCTION STRAINERS AND PULSATION DAMPER" and to the PARTS & SERVICE NEWS No. "AH06519".
- Add hydraulic oil up to the specified level.
- Check and adjust the MRV using Multi Monitor.

WARNING

Wear hearing protection when checking relief pressure.

- Open the cover (Fig. 3-151, Pos. 1) of the return oil filter.
- Transfuse oil from the return manifold into the main oil reservoir, refer to the PARTS & SERVICE NEWS No. "AH10530".

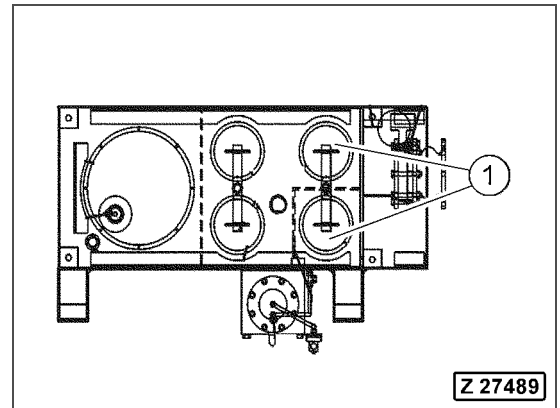

Fig. 3-151

- Disconnect the hydraulic piping (Fig. 3-152, Pos. 1) with the union (Fig. 3-152, Pos. 2) from the throttle check valve (Fig. 3-152, Pos. 3).

NOTE: When the pipes are disconnected, the oil inside the piping and the valve will flow out. Catch it in an oil pan. Cap the openings with blind plugs to avoid contamination.

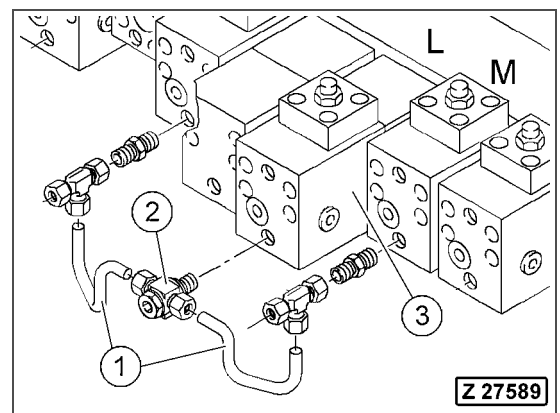

Fig. 3-152

- Disconnect the flex hose (Fig. 3-153, Pos. 5) from the throttle check valve (Fig. 3-153, Pos. 1).
- Remove the four bolts (Fig. 3-153, Pos. 2) and remove the SAE-flange (Fig. 3-153, Pos. 3) from the throttle check valve (Fig. 3-153, Pos. 1).

NOTE: When the hydraulic lines are removed, the oil inside the piping and the valve will flow out. Catch it in an oil pan. Cap the openings with blind plugs to avoid contamination.

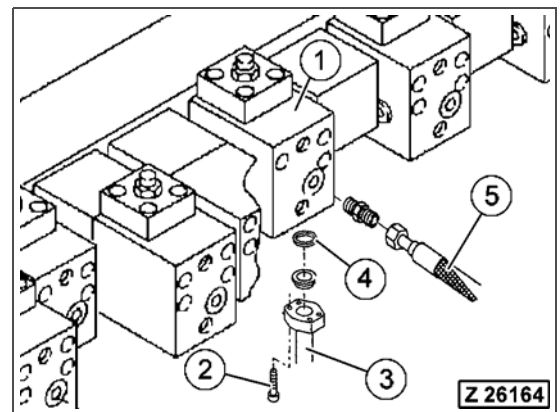





Fig. 3-153

3.7.1.1 REMOVAL OF THE SLEW GEAR BOX

Special tools:	n/a
Additional equipment:	Crane Swivel hoist ring: 4 x M16
	Swing motor with attached slew service brake valve: 260 kg Slew gear box (Siebenhaar): 1700 kg Slew gear box (L&S): 1880 kg
	Dogman/rigger
	For further information about the needed blind plugs, refer to section 6.6 on page 6-16.

NOTE: The machine can be equipped either with a slew gear of manufacturer "L&S" or of manufacturer "Siebenhaar". The removal and the replacement of the slew gear by different manufacturers are analogously the same. Refer to the data plate on each slew gear housing to find out the manufacturer of the slew gear.

- Prepare an area of flat ground large enough to accommodate the machine, boom and crane.
- Park the machine on the prepared flat ground area.

NOTE: If the ground condition is too poor to guarantee safe and stable stand of the machine and the additional working equipment (crane, mobile working platforms, forklift, etc.), make sure that the machine is moved to any location with appropriate ground condition.

- Relieve the pressure in the hydraulic system, refer to the Operation & Maintenance Manual, chapter 3, section "RELIEVE PRESSURE IN THE HYDRAULIC SYSTEM".
- Isolate the machine according to local regulations.

WARNING

Hot hydraulic oil!

Do not carry out the following work on a hot machine.
Wait until the temperature of the hydraulic oil is below 50 °C.
Disobedience may result in personal injury from heated oil.

- Open the cover (Fig. 3-163, Pos. 1) of the return oil filter.
- Transfuse oil from the return manifold into the main oil reservoir, refer to the PARTS & SERVICE NEWS No. "AH10530".

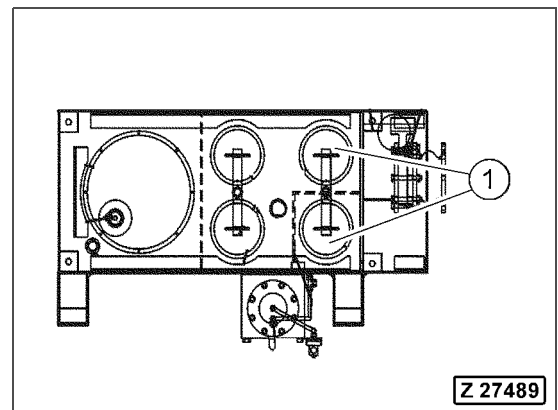

Fig. 3-163

General:

Brake applied:

The outer disks engaged to the housing by serration and the inner disks in serrated connection with the drive shaft are pressed together by the springs. This results in a fixed connection between housing and drive shaft due to the friction between the spring pressurized discs.

Brake released:

Oil pressure via the pilot port reaches the bottom of the piston and forces the piston upwards against the thrust washer and the spring force. This eliminates the spring force towards the disks so that the friction between the discs is released and the inner shaft can rotate. Only the brake of the L&S gear box uses an additional spacer ring (sinus ring) to keep the discs apart. It should reduce the friction in released condition.

The minimum release pressure is 12 bar. In normal working conditions, the releasing pressure X2 is about 35 bar.

NOTE: The swing parking brake must only be applied with the superstructure at a complete standstill. Applying the parking brake with superstructure still slewing may result in severe damage to the brake.

▲ WARNING

- **Only use the swing parking brake in emergency situations to stop the rotating superstructure.**
 - **If the parking brake has been used for an emergency stop, it is necessary to shut down the excavator and to have the parking brake of the swing gear inspected and repaired if necessary. Contact your Komatsu dealer for repairing the brakes.**
-

NOTE: When replacing the swing circle, all fastening bolts must also be replaced.

- Install three swivel hoist rings displaced by 120° at the inner slew ring and lift it using a crane.

⚠ DANGER

Risk of falling weights!

Death or serious injury may result.

When lifting the swing circle, make sure that nobody steps below the lifted weight.

- Place the swing circle (Fig. 3-194, Pos. 2) onto the mounting cross (Fig. 3-194, Pos. 1).
- Centre the swing circle (Fig. 3-194, Pos. 2) on the mounting cross (Fig. 3-194, Pos. 1) with help of the transport star.
- Position the mounting cross with the swing circle resting on it under the superstructure platform (Fig. 3-194, Pos. 3) and connect the mounting cross to a crane.

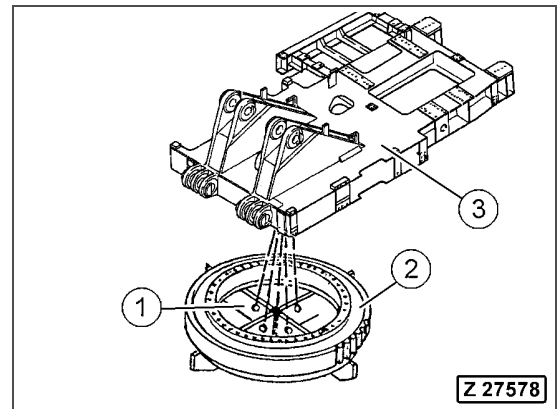

Fig. 3-194

NOTE: In order to avoid damage to the sling accessory, use edge protection at all sharp edges.

The mounting cross is accessible from the center of the machine (Fig. 3-195, arrow).

⚠ CAUTION

In order to avoid damages to the manifold or the pipes between manifold and main control valve blocks, it is recommended that the manifold (Fig. 3-195, Pos. 1) is removed.

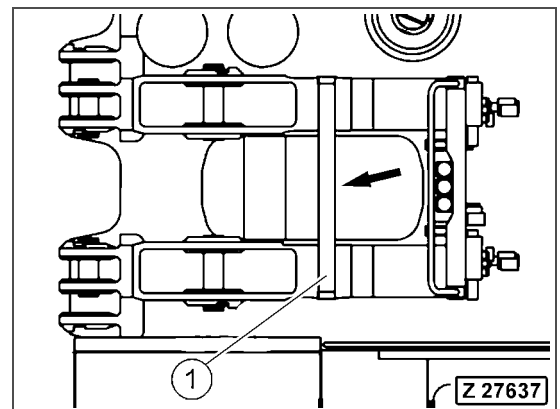

Fig. 3-195

- Mating surfaces must be absolutely fat-free. Even the solvent must be rinsed away before assembling.
- Check flatness of the mating surfaces.

- Remove the mounting bolts (Fig. 3-210, Pos. 1) from all viscous mounts (Fig. 3-210, Pos. 3).

WARNING

Do not remove the mounting bolts (Fig. 3-210, Pos. 1) on both sides of the cabin at the same time.

- Remove the mounting bolts (Fig. 3-210, Pos. 2) of the absorber plate with the viscous mount(s) (Fig. 3-210, Pos. 3) to be removed.
- Raise the Operator's cab using the two jacking screws (Fig. 3-210, Pos. 4) and remove the relevant absorber plate with the viscous mount(s).
- Remove the viscous mount(s) from the absorber plate.

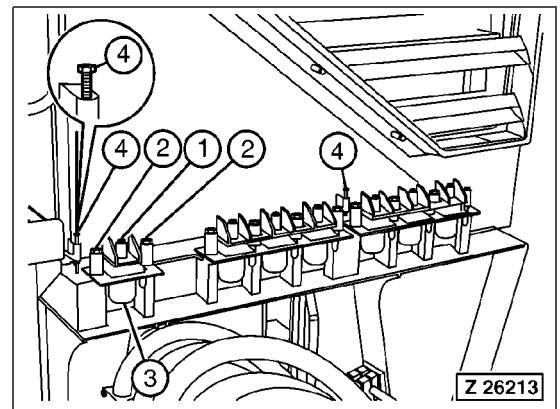



Fig. 3-210

3.9.3.2 REPLACEMENT OF THE CAB MOUNTS



Special tools:	n/a
Additional equipment:	Safety harness in conformity with EN 361 Mobile elevator working platform
	Viscous mount: 4.6 kg Absorber plate 1 incl. viscous mount: 9 kg Absorber plate 2 incl. viscous mounts: 12 kg Absorber plate 3 incl. viscous mounts: 19.5 kg
	If there is nothing mentioned explicitly, tighten all bolts according to KOMATSU company standard, refer to section 6.5 on page 6-12.

WARNING

Always wear a Safety harness when working at the operator's cab.

- Carry out installation in reverse order to removal.
- Unscrew the two jacking screws (Fig. 3-210, Pos. 4) as far as to an unhampered position to the cab base and lock them with a nut.

3.11.2 REPLACEMENT OF ACCESS LADDER

Special tools:	n/a
Additional equipment:	Safety harness in conformity with EN 361 Crane Mobile elevator working platform
	Access ladder: 130 kg
	Dogman/rigger
	If there is nothing mentioned explicitly, tighten all bolts according to KOMATSU company standard, refer to section 6.5 on page 6-12.

WARNING

- Provide an adequate working platform for safe access to the access ladder bearing.
- Always wear a Safety harness when working at the access ladder assembly.

- Carry out installation in reverse order to removal.



Tightening procedure for the self-locking nuts (Fig. 3-222, Pos. 2):
Tighten the nuts until they have contact with the ladder carrier frame.
Then tighten the nuts by turning them by 45° (1/8 turn).

NOTE: Apply grease to the pivot pin (Fig. 3-222, Pos. 6) at the access ladder cylinder moving rod.

⚠ DANGER

Risk of falling weights!**May result in death or serious injury**

When moving superstructure, make sure that all personnel are clear.

NOTE: The unhardened spot of race surfaces (changeover area between beginning and ending of hardening process) is punch marked with an "S" at the inner resp. outer side of each slew ring (Fig. 3-234, Pos. 1 and 2).

- Align the spots (Fig. 3-234, Pos. S) to each other.
- Prepare new bolts and sleeves. Lubricate the threads and the head surface of the bolts with compound, PN 324 969 40.
- Remove the torque support lever of the rotary joint before installing the superstructure, refer to section 4.3.3.1 on page 4-84.

NOTE: To simplify the alignment of the slew ring to the undercarriage, install two threaded pins M 30 x 250 (Fig. 3-234, Pos. 3) displaced by 180° at the outer slew ring (Fig. 3-234, Pos. 2).

- Align the superstructure to the undercarriage and lower the superstructure.
- Insert 4 bolts (Fig. 3-235, Pos. 3) with resilient sleeves (Fig. 3-235, Pos. 2) displaced by 90° and lower the superstructure.
- Remove the two threaded pins from the outer slew ring.
- Install all remaining bolts and tight them manually.

 **Tighten all bolts crosswise to the required torque, refer to the PARTS & SERVICE NEWS No. "AH00511" last edition.**

NOTE: If approx. 10 bolts (front and rear) are tightened the superstructure can be unhooked from the crane.

- Reinstall the torque support lever of the rotary joint.

⚠ CAUTION

Make sure to use the specified bolts and torque for the torque support lever mounting bolts, refer to section 4.3.3.2 on page 4-87.

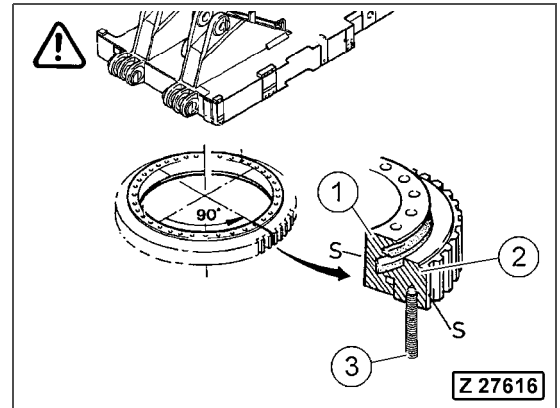

Fig. 3-234

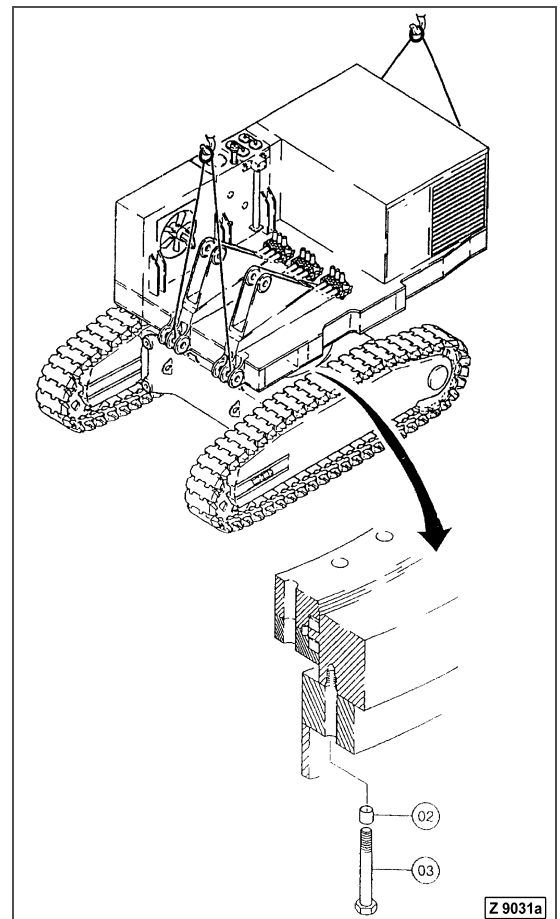

Fig. 3-235

- Flame-cut the nuts (Fig. 4-3, Pos. 3) from the locking bolts (Fig. 4-3, Pos. 1). Remove the locking bolts (Fig. 4-3, Pos. 1), washers (Fig. 4-3, Pos. 2), and nuts (Fig. 4-3, Pos. 3) from one track shoe (Fig. 4-3, Pos. 5).

⚠ WARNING

- Ensure nothing flammable is in the working area during flame-cutting and welding work.
 - For welding follow the welding precautions given in the Operation & Maintenance Manual, chapter 4, section "WELD REPAIRS".
-

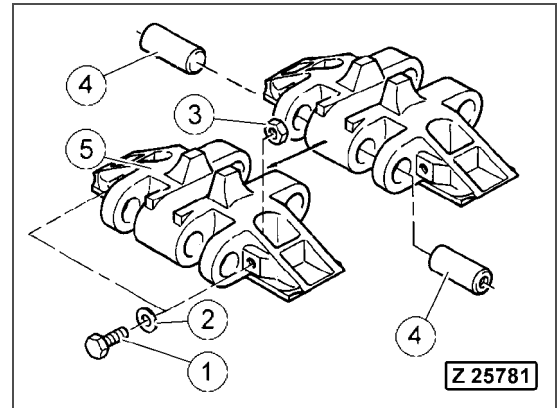

Fig. 4-3

- Pull out two pins (Fig. 4-3, Pos. 4) to open the track group using the pin-driving press, PN 232 313 40.

NOTE: Open the track group at the guide wheel side for track group exchange.

- Sling the upper end of the track group using a chain and link it to a dozer in front of the excavator.

NOTICE: The dozer must stand in a distance of more than the length of the full unrolled track group.

- De-isolate the machine according to local regulations.
- Switch S155 to Q_{min} .

⚠ DANGER

**Danger of getting overrun or squished.
 Serious injury or death may result.
 Make sure nobody stays in driving direction of the excavator or the dozer.
 Make sure nobody stays next to the crawler carrier.**

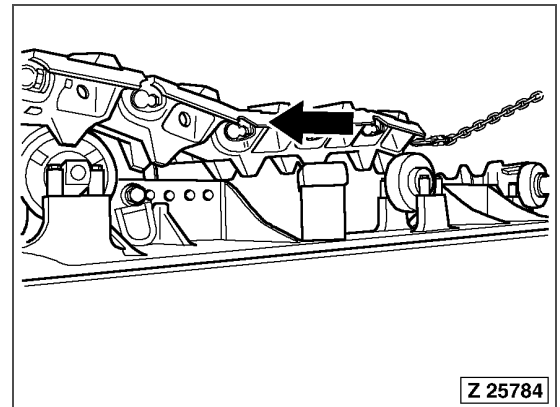

Fig. 4-4

- Drive the excavator and the dozer backwards slowly and unroll the track group from the excavator (Fig. 4-4).

NOTE: The dozer must drive twice as fast as the excavator and travels the double distance.

- When the upper end of the track group runs off the sprocket, stop the excavator while driving the dozer backwards slowly to prevent the track from knocking over.

▲ DANGER**Danger of hydraulic pressure.**

May result in blindness, serious injury, permanent disfigurement, or scaring.

The hydraulic system may be pressurized. Make sure that the pressure is relieved before any hydraulic lines will be removed.

- Disconnect the pressure hose (Fig. 4-30, Pos. 1).

NOTE: When the pressure hose is removed, hydraulic oil from inside the piping and the pressure accumulator will flow out.

Catch it in an oil pan.

Cap the openings with blind plugs to avoid contamination.

- Remove four bolts (Fig. 4-30, Pos. 2) and remove the pressure accumulator (Fig. 4-30, Pos. 3).
- Remove socket (Fig. 4-30, Pos. 4) and union (Fig. 4-30, Pos. 5).

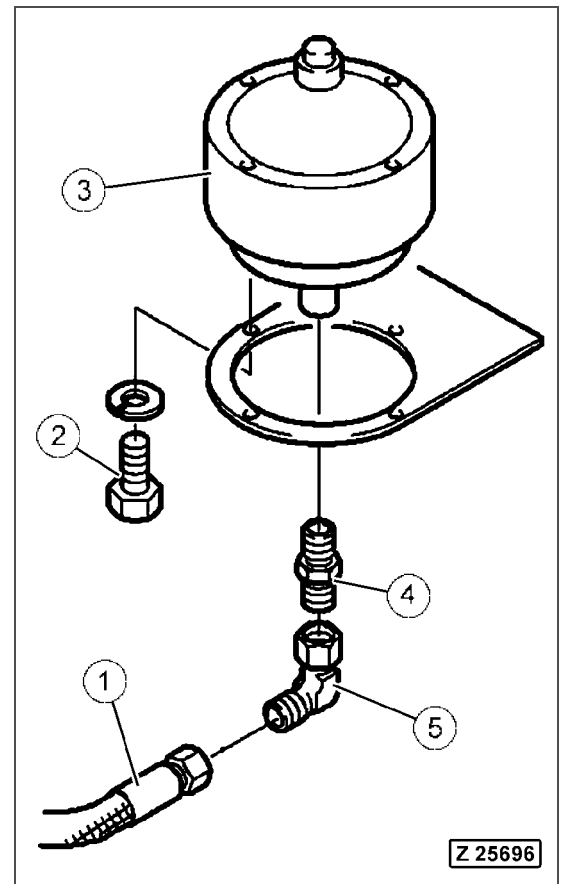

Fig. 4-30

- Disconnect the hose (Fig. 4-43, Pos. 6) and pull it out.

NOTE: At this, the new hose is pulled in place.

- Disconnect the old hose and the union from the new hose and install it in reverse order to removal.
- Carry out the subsequent work, refer to section 4.2.7.5 on page 4-34.

4.2.7.4 SUBSTITUTE THE HYDRAULIC HOSES INSIDE THE CRAWLER FRAME

Hydraulic hose:

Fig. 4-40, Pos. 7 to 9

- Carry out the precursory work, refer to section 4.2.7.1 on page 4-29.
- Remove the covers (Fig. 4-44, Pos. 1 and 2).

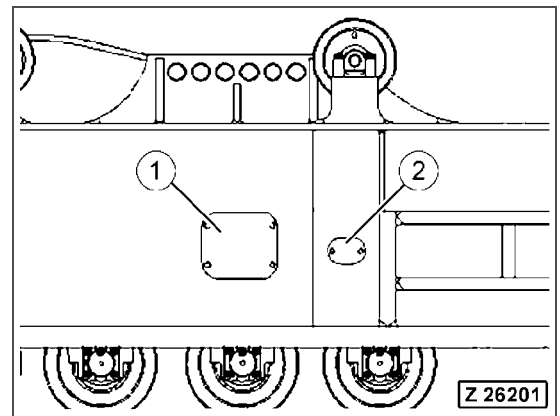

Fig. 4-44

- Open the respective hose clamps (Fig. 4-43, F) to clear the hydraulic hoses (Fig. 4-43, Pos. 7 and 8) from the crawler frame.
- Disconnect both ends of the hydraulic hoses (Fig. 4-43, Pos. 7 to 9) and remove the hydraulic hoses.

NOTE: When a hose is disconnected, hydraulic oil from inside the piping or the hose will flow out.
Catch it in an oil pan.
Cap the openings with blind plugs to avoid contamination.

- Install a new hydraulic hose in reverse order to removal.
- Carry out the subsequent work, refer to section 4.2.7.5 on page 4-34.

⚠ WARNING

Hot hydraulic oil!

Do not carry out the following work on a hot machine. Wait until the temperature of the hydraulic oil is below 50 °C. Disobedience may result in personal injury from heated oil.

⚠ DANGER

Danger of hydraulic pressure.

May result in blindness, serious injury, permanent disfigurement, or scarring.

The hydraulic system may be pressurized. Make sure that the pressure is relieved before any hydraulic lines will be removed.

- Remove the travel motor (Fig. 4-54, Pos. 3) but leave all hoses connected, refer to section 4.2.9.1 on page 4-41.

NOTE: Support the travel motor, so that the hydraulic hoses are not stressed.

- Remove the pressure hose (Fig. 4-54, Pos. 1) and the breather hose (Fig. 4-54, Pos. 2) from the travel parking brake (Fig. 4-54, Pos. 4).

NOTE: When the pressure hose is removed, hydraulic oil from inside the piping will flow out. Catch it in an oil pan. Cap the openings with blind plugs to avoid contamination.

- Sling the travel parking brake.
- Remove the mounting bolts of the travel parking brake and remove the travel parking brake by pulling it out of the travel gear box (Fig. 4-54, Pos. 5) using a crane.

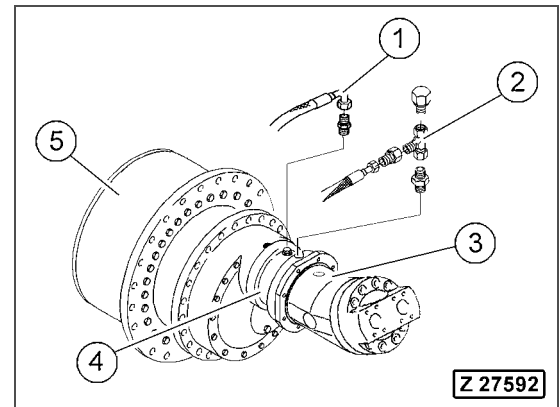

Fig. 4-54

⚠ DANGER

Risk of falling weights!

Death or serious injury may result.

When lifting the travel parking brake, make sure that nobody steps below the weight.

NOTE: When the travel parking brake is removed, a rest of oil from inside the brake will flow out. Catch it in an oil pan to avoid contamination.

- Check the oil level in the carrier roller. The following positions of the oil level and filler plug have been defined for checking the oil level in the carrier rollers:
 - 9.00 o'clock or 3.00 o'clock position, equal to 90° angle from TOP position of the plug to left or to the right = MINIMUM oil level.
 - 9.30 o'clock or 2.30 o'clock position, equal to 75° angle from TOP position of the plug to left or to the right = MAXIMUM oil level (factory filling).

NOTE: For information about the proper lubricant, refer to the Operation & Maintenance Manual, chapter 4, section "FLUIDS AND LUBRICANTS".

- Insert new bolts (Fig. 4-79, Pos. M48) and two new measuring bolts (Fig. 4-79, Pos. 7) with a resilient sleeve and pre tighten with specified torque.

NOTE: Lubricate all bolts (Fig. 4-79, Pos. M48) with MPG (Multi Purpose Grease).

Clean bottom and top surface of resilient sleeves and contact area completely free of paint.

Use the hydraulic torque wrench PN 793 376 73 + PN 793 374 73, refer to section 6.3.2 on page 6-6.



Pre tightening torque for crawler carrier mounting bolts: 2100 Nm

- Lift the car body on the left side using a crane.
- Support left side of the car body with appropriate stands. The left side should be approx. 200 mm higher than the other side (Fig. 4-77 and Fig. 4-78). Lower the car body on the stands.

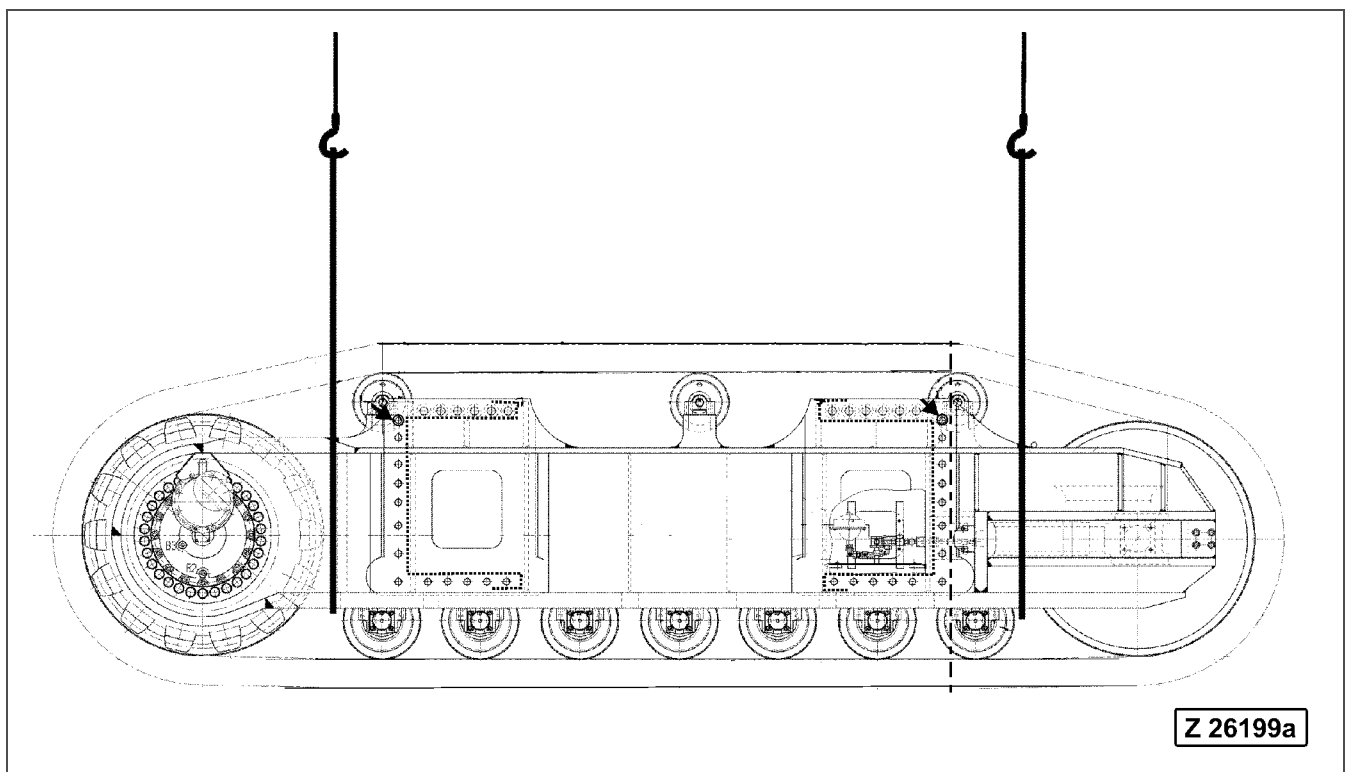

Fig. 4-80 Crawler carriers attached to cranes

WARNING

Before lifting the crawler carrier, make sure that the crane operators are trained in dual crane lift.



- Lift the left crawler carrier with two cranes (Fig. 4-80) and align it with the car body.

5 ATTACHMENT

- Check bushes for wear and damage. Replace if required.
- If required, disconnect the other boom cylinder from the boom and remove it using the same procedure.
- If required, remove the pipe work from the removed cylinder(s). Discard the seals, fit the caps to the cylinder(s) openings to avoid environmental contamination.

Legend for Fig. 5-25:

- (1) Stick cylinder
- (2) Stick
- (3) Boom
- (4) Bolt
- (5) Shackle
- (6) Pin
- (7) Seal
- (8) Bolt
- (9) Shackle
- (10) Catch
- (11) Pin
- (12) Pipe
- (13) Seal
- (14) Seal
- (15) Bush

Special tools:	n/a
Additional equipment:	Safety harness in conformity with EN 361 2 x crane Mobile elevator working platform
	Stick Cylinder: 2420 kg Pin stick cylinder/stick: 82 kg Pin stick cylinder/boom: 84 kg
	Dogman/rigger
	For further information about the needed blind plugs, refer to section 6.6 on page 6-16.

WARNING

- Always wear a Safety harness when working at the attachment.
- Most of the following operations require the use of men safety cages on elevator working platforms.

NOTE: At first the wear of the bushes in the hydraulic cylinders should be checked, refer to the PARTS & SERVICE NEWS No. "AH08508".

Legend for Fig. 5-40:

- (1) Seal fixing ring
- (2) Bucket link rod
- (3) Lock
- (4) Nut-cap
- (5) Right-hand steering rod
- (6) Pin
- (7) Thread hole
- (8) Left-hand steering rod
- (9) Moving rod
- (10) Cylinder body
- (11) Bolt
- (12) Shackle
- (13) Pin
- (14) Seal
- (15) Pipe
- (16) Seal
- (17) Seal
- (18) Bush

- Remove the seal fixing rings (Fig. 5-58, Pos. 1) located on both sides between the steering rod (Fig. 5-58, Pos. 6) and the stick (Fig. 5-58, Pos. 7).
- Remove the bolt (Fig. 5-58, Pos. 2) and undo the lock (Fig. 5-58, Pos. 3)
- Remove the nut-cap (Fig. 5-58, Pos. 4) from the pin (Fig. 5-58, Pos. 5), then fit the "Thread Protector" PN 409 329 40.
- Pull the pin (Fig. 5-58, Pos. 5 / Fig. 5-56, Pos. 4) out completely to clear both steering rods or if removing the right-hand steering rod only, pull the pin out just enough to clear the right-hand steering rod.

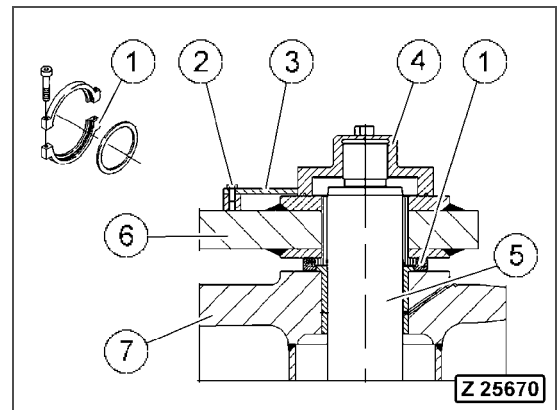

Fig. 5-58

⚠ WARNING

Sling the pin as soon as it is possible and support it using a crane to prevent the pin from falling.

NOTE: Pull the pin (Fig. 5-58, Pos. 5) out using two puller bolts at threaded holes (Fig. 5-59, Pos. 1).

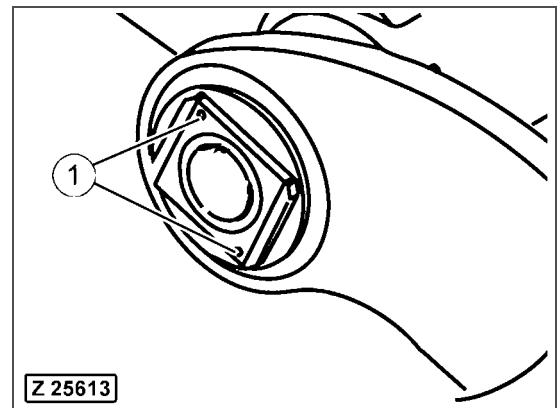





Fig. 5-59

- Remove the steering rod(s) using a crane.

⚠ DANGER

**Risk of falling weights!
Death or serious injury may result.
When moving the steering rod, make sure that nobody steps below the lifted weight.**

Special tools:	n/a
Additional equipment:	Safety harness in conformity with EN 361 Crane Oil drain pan Mobile elevator working platform
	Stick cylinder hoses: 24.6 kg
	Dogman/rigger
	f there is nothing mentioned explicitly, tighten all bolts according to KOMATSU company standard, refer to section 6.5 on page 6-12. For further information about the needed blind plugs, refer to section 6.6 on page 6-16.

WARNING

- Always wear a Safety harness when working at the attachment.
- Most of the following operations require the use of men safety cages on elevator working platforms.

- Prepare an area of flat ground large enough to accommodate the machine, boom and crane.
- Park the machine on the prepared flat area and position the bucket on the ground with the bucket cylinders in fully extended and the stick cylinders in fully retracted position (Fig. 5-71).

NOTE: If the ground condition is too poor to guarantee safe and stable stand of the machine and the additional working equipment (crane, mobile working platforms, forklift, etc.), make sure that the machine is moved to a location with appropriate ground condition.

- Relieve the pressure in the hydraulic system, refer to the Operation & Maintenance Manual, chapter 3, section "RELIEVE PRESSURE IN THE HYDRAULIC SYSTEM".
- Isolate the machine according to local regulations.

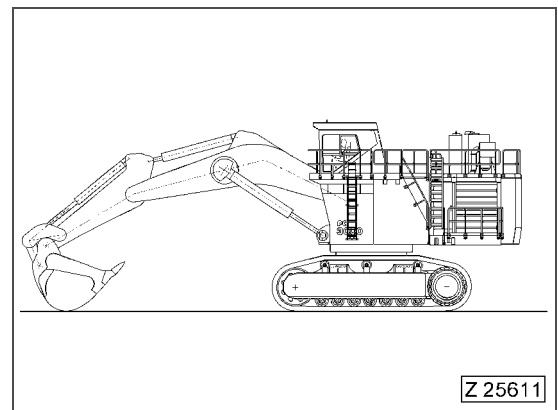

Fig. 5-71

- Relieve the pressure in the hydraulic system, refer to the Operation & Maintenance Manual, chapter 3, section "RELIEVE THE PRESSURE IN THE HYDRAULIC SYSTEM".
- Isolate the machine according to local regulations.

▲ DANGER

Danger of hydraulic pressure!

Blindness, serious injury, permanent disfigurement, or scarring may result.

The hydraulic system may be pressurized. Make sure that the pressure is relieved before any hydraulic line will be removed.

- Disconnect the boom arc hoses incl. grease feeding lines from the boom, refer to section 5.2.6.1 on page 5-144.

NOTE: When the hydraulic hoses are disconnected, the oil inside the piping will flow out. Catch it in an oil pan.

Cap the openings with blind plugs to avoid contamination.

- Attach the second crane to the rear part of the boom.
- Remove the bolts (Fig. 5-82, Pos. 1) and the shackles (Fig. 5-82, Pos. 2) securing the pins (Fig. 5-82, Pos. 4).
- Remove the pins (Fig. 5-82, Pos. 4) attaching the boom to the superstructure.

▲ WARNING

Sling the pin as soon as possible and support it using a crane to prevent the pin from falling.

- Remove the boom with attached stick cylinders and boom cylinders using two cranes. Place it on appropriate stands.

▲ WARNING

Make sure that the crane operators are trained in dual crane lift.

▲ DANGER

Risk of falling weights!

Death or serious injury may result.

When moving the boom, make sure that nobody steps below the lifted boom.

- Switch S155 to Q_{\min} and retract the boom cylinder fully.
- Remove the wire rope securing the piston rod of the boom cylinder.
- Extend and retract the boom cylinder (Fig. 5-92, Pos. 1) slowly at Q_{\min} 2...3 times as far as possible to partly bleed the cylinder.

▲ WARNING

The air in the cylinder will result in slightly jerky movements of the cylinder.



- Operate the boom cylinder slowly at Q_{\min} and use the chain hoist to align the boom cylinders to the superstructure.

▲ DANGER

Never put hands into the holes when aligning the boom cylinder to the superstructure.

- Insert the pin (Fig. 5-92, Pos. 5).
- Isolate the machine according to local regulations.
- Install the shackle (Fig. 5-92, Pos. 4) and the bolt (Fig. 5-92, Pos. 3) to secure the pin (Fig. 5-92, Pos. 5).
- Detach the chain hoist from the boom cylinder body.
- Carry out further installation in reverse order to removal.
- De-isolate the machine according to local regulations.
- Perform the bleeding procedure for the boom cylinders. Refer to the PARTS & SERVICE NEWS No. "AH06524".
- Bleed air from the hydraulic system, refer to the Operation & Maintenance Manual, chapter 4, section "HYDRAULIC SYSTEM - CHANGE OIL, REPLACE SUCTION STRAINERS AND PULSATION DAMPER" and to the PARTS & SERVICE NEWS No. "AH06519".
- Add hydraulic oil up to the specified level.
- Check for leaks and the cylinders operation.
- Check the hydraulic oil level again and add oil if required.

5.2.3.4 REPLACEMENT OF THE STICK CYLINDERS

Special tools:	n/a
Additional equipment:	Safety harness in conformity with DIN EN 361 Forklift 2 x chain hoist Crane Mobile elevator working platform (telescopic or articulated boom lift)
	Stick cylinder: 1635 kg Pin stick cylinder/boom: 60.5 kg Pin stick cylinder/stick: 52 kg
	Dogman/rigger
	If there is nothing mentioned explicitly, tighten all bolts according to KOMATSU company standard, refer to section 6.5 on page 6-12.

WARNING

- Always wear a safety harness when working at the attachment.
- Most of the following operations require the use of men safety cages on elevator working platforms.

NOTE: When performing the installation procedures, comply to the following:

Always discard used seals and install new seals!

Apply the appropriate grease on every bush and pin on assembly!

- If required, install the pipe work, the connecting blocks, and the seals at the cylinder(s).
- Attach two chain hoists to the underside of the boom.
- For safety reasons tie the piston rod to the cylinder body with a wire rope.
- Place the stick cylinder on a forklift horizontally, and position the stick cylinder right underneath the chain hoists.
- Connect a chain hoist to each side of the stick cylinder.

DANGER

Risk of falling weights!

Death or serious injury may result.

When moving the stick cylinder, make sure that nobody steps below the lifted cylinder.

- Support the bucket cylinder by means of the installation tool using the forks of a forklift.
- Remove the bolts (Fig. 5-115, Pos. 3), the washers (Fig. 5-115, Pos. 2) and the shackle (Fig. 5-115, Pos. 4).
- Remove the pin (Fig. 5-115, Pos. 1) to clear the bucket cylinder from the boom.

WARNING

Slung the pin as soon as possible and support it using a crane to prevent the pin from falling.

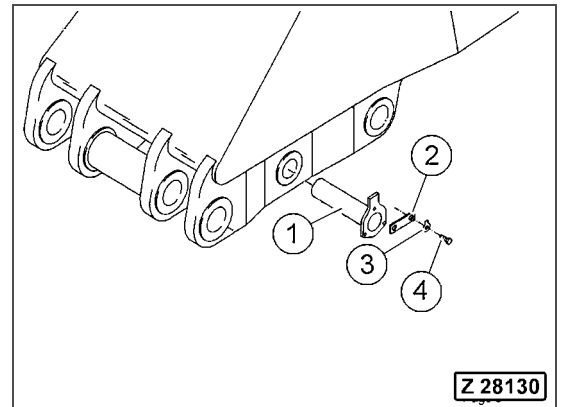

Fig. 5-115

- De-isolate the machine according to local regulations.
- Switch S155 to Q_{min} and retract the bucket cylinder fully.
- Tie the piston rods to the bucket cylinder body with a wire rope.
- Relieve the pressure in the hydraulic system, refer to the Operation & Maintenance Manual, chapter 3, section "RELIEVE THE PRESSURE IN THE HYDRAULIC SYSTEM".
- Isolate the machine according to local regulations.

WARNING

Hot hydraulic oil!

Do not carry out the following work on a hot machine. Wait until the temperature of the hydraulic oil is below 50 °C. Disobedience may result in personal injury from heated oil.

DANGER

Danger of hydraulic pressure!

Blindness, serious injury, permanent disfigurement, or scarring may result.

The hydraulic system may be pressurized. Make sure that the pressure is relieved before any hydraulic line will be removed.

- Disconnect the hydraulic hoses from the bucket cylinder, refer to section 5.2.6.5 on page 5-164.

NOTE: When the hydraulic hoses are disconnected, the oil inside the piping and the hoses will flow out. Catch it in an oil pan.

Cap the openings with blind plugs to avoid contamination.

- Insert the pin (Fig. 5-130, Pos. 3) connecting clam cylinder (Fig. 5-130, Pos. 2) to the bucket clam (Fig. 5-130, Pos. 1).
- Relieve the pressure in the hydraulic system, refer to the Operation & Maintenance Manual, chapter 3, section "RELIEVE PRESSURE IN THE HYDRAULIC SYSTEM".
- Isolate the machine according to local regulations.
- Install the shackle (Fig. 5-130, Pos. 5), with the bolts (Fig. 5-130, Pos. 6) and lock washers (Fig. 5-130, Pos. 7).

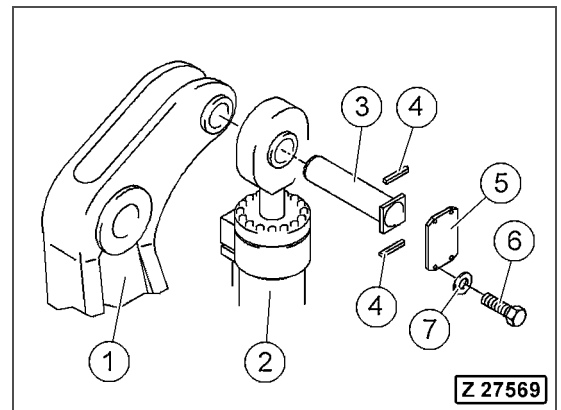





Fig. 5-130

- Detach the crane and remove the supporting blocks from the clam cylinder.
- Carry out further installation in reverse order to removal.
- Perform the bleeding procedure for the clam cylinders. Refer to the PARTS & SERVICE NEWS No. "AH06524".
- Bleed air from the hydraulic system, refer to the Operation & Maintenance Manual, chapter 4, section "HYDRAULIC SYSTEM - CHANGE OIL, REPLACE SUCTION STRAINERS AND PULSATION DAMPER" and to the PARTS & SERVICE NEWS No. "AH06519".
- Add specified hydraulic oil up to the specified level.
- Check for leaks and the cylinders operation.
- Check the hydraulic oil level again and add oil if required.

Legend for Fig. 5-138:

- (1) Hose clamp line
- (2) Boom
- (3) Bolt
- (4) Hydraulic pipe
- (5) Hydraulic hose
- (6) Ring
- (7) O-Ring



Special tools:	n/a
Additional equipment:	Safety harness in conformity with DIN EN 361 Crane Mobile elevator working platform (telescopic or articulated boom lift) Oil drain pan
	Stick arc hose: 17 kg...27 kg (depending on diameter)
	Dogman/rigger
	If there is nothing mentioned explicitly, tighten all bolts according to KOMATSU company standard, refer to section 6.5 on page 6-12. For further information about the needed blind plugs, refer to section 6.6 on page 6-16.

NOTE: In case that two hose clamp lines (Fig. 5-138, Pos. 1) are installed, KOMATSU recommends the replacing of the hydraulic lines on the stick and the boom and the hydraulic hoses between stick and boom (stick arc hoses).

Follow the instructions given in the PARTS & SERVICE NEWS No. "AH08530".

WARNING

- Always wear a safety harness when working at the attachment.
- Most of the following operations require the use of men safety cages on elevator working platforms.

Special tools:	n/a
Additional equipment:	Crane Mobile elevator working platform (telescopic or articulated boom lift) Oil drain pan
	Clam cylinder hose at stick: 26 kg
	Dogman/rigger
	If there is nothing mentioned explicitly, tighten all bolts according to KOMATSU company standard, refer to section 6.5 on page 6-12. For further information about the needed blind plugs, refer to section 6.6 on page 6-16.

WARNING

- Always wear a safety harness when working at the attachment.
- Most of the following operations require the use of men safety cages on elevator working platforms.

- Prepare an area of flat ground large enough to accommodate the machine, boom, and crane.
- Park the machine on the prepared flat area with the superstructure turned by 90° and position the bucket on the ground as shown (Fig. 5-148).

NOTE: If the ground condition is too poor to guarantee safe and stable stand of the machine and the additional working equipment (crane, mobile working platforms, forklift, etc.), make sure that the machine is moved to any location with appropriate ground condition.

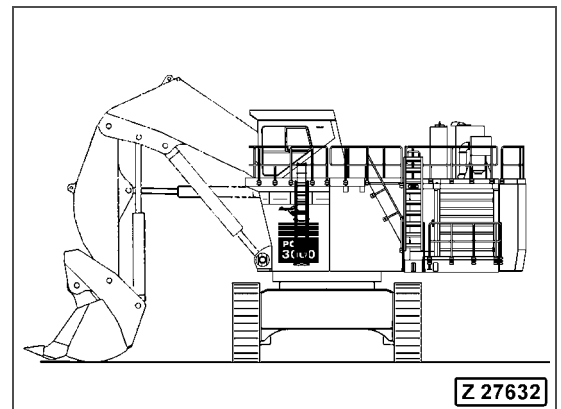

Fig. 5-148

- Relieve the pressure in the hydraulic system, refer to the Operation & Maintenance Manual, chapter 3, section "RELIEVE THE PRESSURE IN THE HYDRAULIC SYSTEM".
- Isolate the machine according to local regulations.
- Sling the hydraulic hose (Fig. 5-147, Pos. 1) to be removed.

6 SERVICE INFORMATION

CLICK HERE TO **DOWNLOAD** THE COMPLETE MANUAL

- Thank you very much for reading the preview of the manual.
- You can download the complete manual from: www.heydownloads.com by clicking the link below



- Please note: If there is no response to CLICKING the link, please download this PDF first and then click on it.

CLICK HERE TO **DOWNLOAD** THE COMPLETE MANUAL