

# Shop Manual

HYDRAULIC  
EXCAVATOR

***PC2000-11***

SERIAL NUMBERS 30001 and up

**KOMATSU**

CLICK HERE TO **DOWNLOAD** THE COMPLETE MANUAL

- Thank you very much for reading the preview of the manual.
- You can download the complete manual from: [www.heydownloads.com](http://www.heydownloads.com) by clicking the link below



- Please note: If there is no response to CLICKING the link, please download this PDF first and then click on it.

CLICK HERE TO **DOWNLOAD** THE COMPLETE MANUAL

**REMARK**

- The figure shows an example of fitting of O-ring.
- An O-ring is fitted to every joint of the air conditioner piping.

For tightening torques, see THE OTHER INFORMATION, "Precautions for disconnection and connection of air conditioner piping".

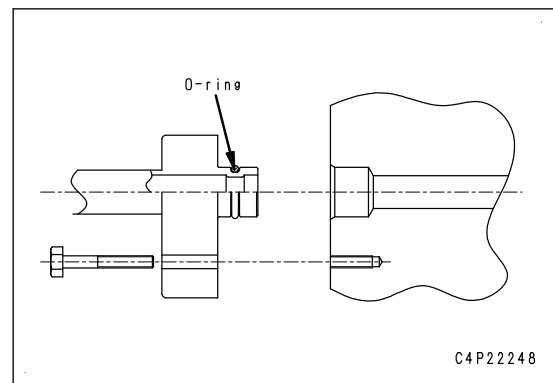
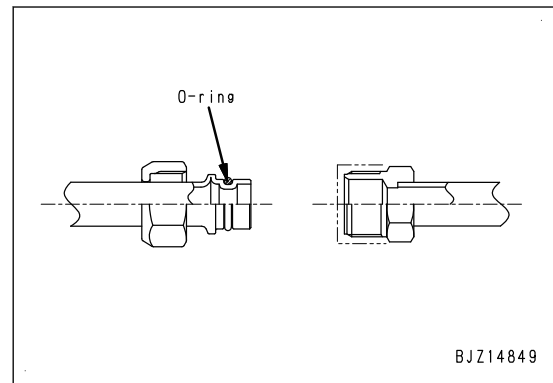

## Standard clearance and standard value

- The clearance made when new parts are assembled is called the standard clearance, which is indicated by the range from the minimum clearance to the maximum clearance.
- When some parts are repaired, the clearance is generally adjusted to the standard clearance.
- The values indicating performance and function of new products or equivalent are called “standard value”, which is indicated by a range or a target value.
- When some parts are repaired, the value of performance/function is set to the standard value.

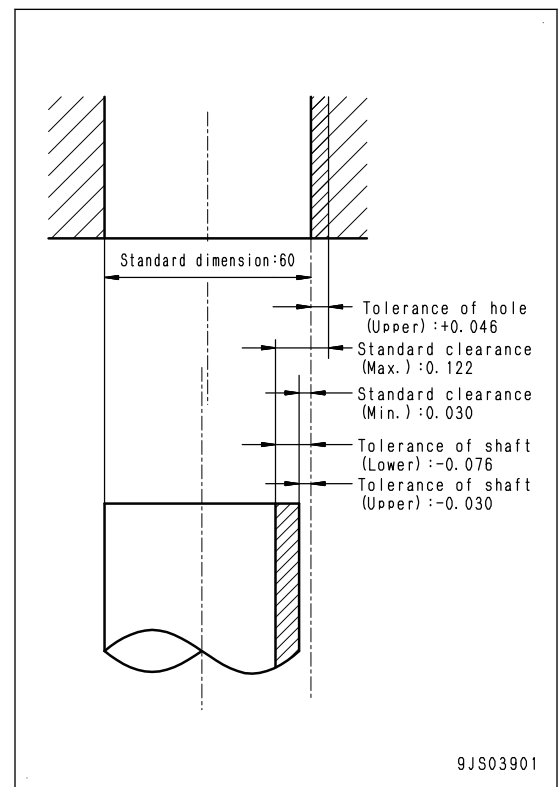

## Standard interference

- When the diameter of a hole of a part shown in the given standard dimension and tolerance table is smaller than that of the shaft to be inserted, the difference between those diameters is called “interference”.
- Subtract the maximum dimension of the hole from the minimum dimension of the shaft and call it (A). Subtract the minimum dimension of the hole from the maximum dimension of the shaft and call it (B). The range between (A) and (B) is “standard interference”.
- After repairing or replacing some parts, measure the dimension of their hole and shaft and check that the interference is in the standard range.

## Repair limit and allowable value or allowable dimension

- The dimension of parts changes due to the wear or deformation while they are used. When the dimension changes exceeding certain value, parts cannot be used any longer. This value is called “repair limit”.
- If a part is worn to the repair limit, it must be replaced or repaired.
- The performance and function of products lower while they are used. A value with which the product can be used without causing a problem is called “allowable value” or “allowable dimension”.
- A product whose dimension is out of the allowable value, must be repaired. However, since the allowable values are generally estimated through various tests or experiences in most cases, the judgment must be made in consideration of the operating condition and customer's requirement.

## Allowable clearance

- Parts can be used until the clearance between them is increased to a certain limit. The limit at which those parts cannot be used is called “allowable clearance”.
- If the clearance between the parts exceeds the allowable clearance, they must be replaced or repaired.

## Allowable interference

- The allowable maximum interference between the hole of a part and the shaft of another part to be assembled is called “allowable interference”.
- The allowable interference shows the repair limit of the part of smaller tolerance.

WORK EQUIPMENT AND SWING PPC VALVE .....10-229

SUCTION SELECTOR VALVE .....10-235

PPC CUT-OFF VALVE .....10-238

SOLENOID VALVE .....10-243

PILOT CIRCUIT ACCUMULATOR .....10-246

SWING SYSTEM .....10-247

    LAYOUT DRAWING OF SWING SYSTEM .....10-247

    SWING CONTROL SYSTEM DIAGRAM .....10-250

        FUNCTION OF SWING CONTROL SYSTEM.....10-250

    SWING PRIORITY SYSTEM DIAGRAM .....10-253

        OPERATION OF SWING PRIORITY SYSTEM .....10-254

    COMPONENT PARTS OF SWING SYSTEM .....10-255

        SWING MOTOR .....10-255

        SWING MACHINERY .....10-265

        SWING CIRCLE.....10-267

TRAVEL SYSTEM.....10-268

    LAYOUT DRAWING OF TRAVEL SYSTEM .....10-268

    TRAVEL CONTROL SYSTEM DIAGRAM.....10-272

    TRAVEL STRAIGHT SYSTEM DIAGRAM .....10-273

        OPERATION OF TRAVEL STRAIGHT SYSTEM .....10-274

HIC SYSTEM .....10-276

    LAYOUT DRAWING OF HIC SYSTEM .....10-276

    HIC SYSTEM DIAGRAM .....10-277

    OPERATION OF HIC SYSTEM.....10-277

    COMPONENT PARTS OF TRAVEL SYSTEM .....10-280

        TRAVEL MOTOR.....10-280

        FINAL DRIVE.....10-293

        TRAVEL PPC VALVE.....10-295

        CENTER SWIVEL JOINT.....10-299

    ACCUMULATOR FOR HIC SYSTEM.....10-300

        STRUCTURE OF ACCUMULATOR FOR HIC SYSTEM .....10-300

        SPECIFICATIONS OF ACCUMULATOR FOR HIC SYSTEM.....10-300

LIFTING SYSTEM .....10-301

    HYDRAULICALLY OPERATED STAIRWAY SYSTEM .....10-301

        LAYOUT DRAWING OF HYDRAULICALLY OPERATED STAIRWAY SYSTEM .....10-301

        HYDRAULICALLY OPERATED STAIRWAY SYSTEM DIAGRAM .....10-302

        FUNCTION OF HYDRAULICALLY OPERATED STAIRWAY SYSTEM .....10-302

    COMPONENT PARTS OF LIFTING SYSTEM .....10-303

        SWITCH BOX .....10-303

        PROXIMITY SWITCH PART .....10-303

        CONTROL VALVE ASSEMBLY.....10-304

SERVICE CENTER SYSTEM .....10-305

    LAYOUT DRAWING OF SERVICE CENTER SYSTEM .....10-305

    SERVICE CENTER SYSTEM DIAGRAM.....10-307

        FUNCTION OF SERVICE CENTER SYSTEM .....10-307

    COMPONENT PARTS OF SERVICE CENTER SYSTEM .....10-309

        RAISE/LOWER SWITCH .....10-309

        PROXIMITY SWITCH PART .....10-309

        CONTROL VALVE ASSEMBLY.....10-310

        LEFT CONSOLE BOX SECTION IN CAB .....10-311

        SERVICE PANEL PART .....10-311

GREASE LUBRICATION SYSTEM .....10-314

    GREASE LUBRICATION SYSTEM DIAGRAM .....10-314

        FUNCTION OF GREASE LUBRICATION SYSTEM .....10-316

        SPECIFICATIONS OF GREASE LUBRICATION SYSTEM .....10-317

    COMPONENT PARTS OF GREASE LUBRICATION SYSTEM .....10-318

        GREASE PUMP.....10-318

        GREASE GUN .....10-320

## EGR VALVE

### EGR

Abbreviation for Exhaust Gas Recirculation

## STRUCTURE OF EGR VALVE

### Sectional view

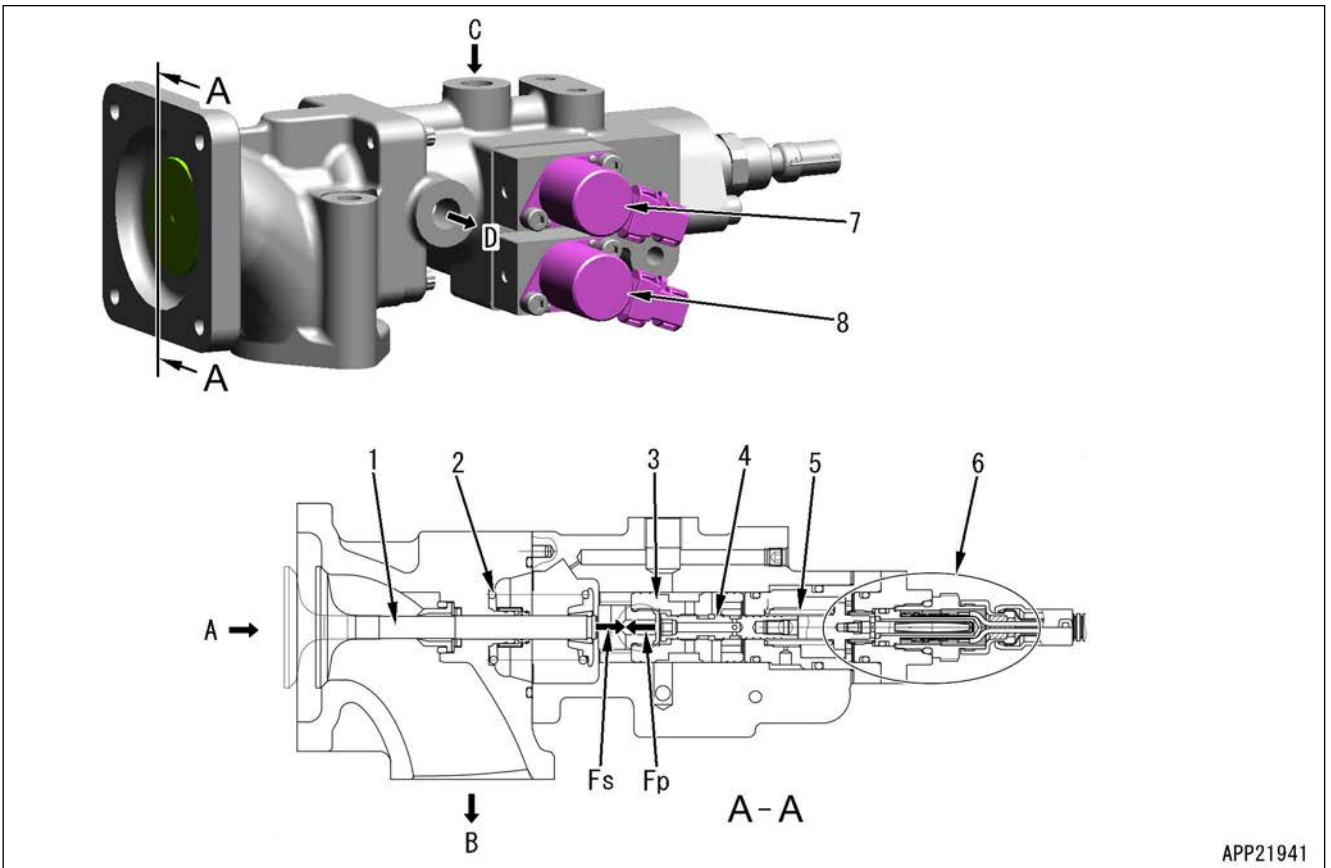

APP21941

A: EGR gas inlet (from EGR cooler)

B: EGR gas outlet (to intake manifold)

1: Valve

2: Spring

3: Power piston

4: Spool

C: Servo drive oil inlet

D: Servo drive oil outlet

5: Spring

6: EGR valve lift sensor

7: EPC valve (for EGR)

8: EPC valve (for VGT)

### Structure

- The EGR valve consists of the EGR gas flow control mechanism and EPC valve.

**OPERATION OF SAFETY VALVE OF COOLING FAN MOTOR**

1. The valve (2) of the safety valve (1) opens to release the pressurized oil into port (T) when the pressure in port (P) exceeding the cracking pressure of safety valve (1). The safety valve (1) prevents occurrence of abnormally high pressure in the port (P).

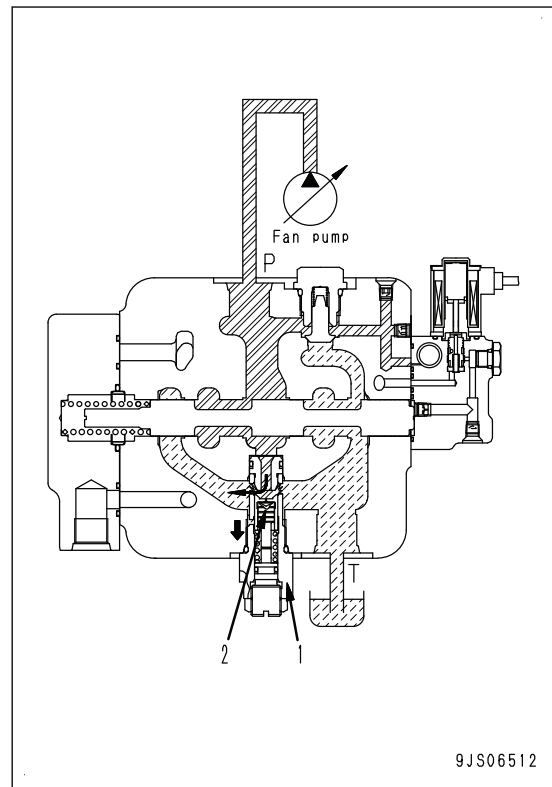

## INPUT AND OUTPUT SIGNALS OF VALVE CONTROLLER 1 DRC24Pin (CP04 connector)

Pin No.	Signal name	Input and output
1	Swing right PPC pressure sensor	Input
2	Arm OUT PPC pressure sensor	Input
3	(*1)	Input
4	GND (analog signal)	-
5	PPC lock solenoid valve monitor signal	Input
6	(*1)	Input
7	Swing left PPC pressure sensor	Input
8	Arm IN PPC pressure sensor	Input
9	(*1)	Input
10	(*1)	-
11	PPC lock	Input
12	(*1)	Input
13	Bucket DUMP PPC pressure sensor	Input
14	Boom LOWER PPC pressure sensor	Input
15	(*1)	Input
16	(*1)	Output
17	Key switch (Terminal C)	Input
18	PPC lock switch (solenoid side)	Input
19	Bucket CURL PPC pressure sensor	Input
20	Boom RAISE PPC pressure sensor	Input
21	GND (analog signal)	-
22	5V potentiometer power supply_0	Output
23	Key switch (Terminal ACC)	Input
24	PPC lock solenoid valve emergency drive switch monitor signal	Input

\*1: Never connect these pins, otherwise it may cause malfunctions or failures.

## DRC40Pin (CP05 connector)

Pin No.	Signal name	Input and output
1	5V potentiometer power supply_1	Output
2	Swing prolix switch	Input
3	(*1)	Input
4	(*1)	Input
5	Travel left reverse PPC pressure sensor	Input
6	(*1)	Input
7	Model selection 4	Input
8	(*1)	Output
9	(*1)	Output

CE1: Front EPC output pressure pickup port  
 CE2: Rear EPC output pressure pickup port  
 CH1: Front EPC source pressure pickup port  
 CH2: Rear EPC source pressure pickup port  
 CP1: Front pump discharged pressure pickup port  
 CP2: Rear pump discharged pressure pickup port  
 CPR: Pilot source pressure pickup port  
 CS1: Front control pressure pickup port  
 CS2: Rear control pressure pickup port  
 E1: Front EPC command current  
 E2: Rear EPC command current  
 E3: Front swash plate angle sensor output voltage  
 E4: Rear swash plate angle sensor output voltage  
 P1: Discharge port  
 P2: Discharge port  
 PF: Self pressure reducing valve source pressure port  
 PR3: Pilot source pressure input port (rear of the inline filter attached to the machine body)  
 1: Front pump  
 2: Rear pump  
 3: VC valve  
 4: EPC valve

PR4: Pilot source pressure output port (front of the in-line filter attached to the machine body)  
 PR5: Pilot source pressure pickup port  
 S: Intake port  
 T1: Drain port  
 T2: Drain plug  
 T3: Drain plug  
 T4: Drain plug  
 T5: Drain plug  
 T6: Air bleeder  
 T7: Drain branch piping port  
 T8: Drain plug  
 T9: Drain plug  
 T10: Drain plug  
 T11: Drain plug  
 5: Self-pressure reducing valve  
 6: Filter  
 7: Swash plate angle sensor (for the front)  
 8: Swash plate angle sensor (for the rear)

**Outline**

The hydraulic pump consists of two variable displacement swash plate type piston pumps, VC valve, EPC valve, and self-pressure reducing valve.

B21: To the boom cylinder bottom  
B31: To the bucket cylinder bottom

B41: To the swing motor [Port (MA)]  
B51: To the right travel motor [Port (PB)]

## PPC CUT-OFF VALVE

### STRUCTURE OF PPC CUT-OFF VALVE

- 5: Yoke
- 6: Plunger
- 7: Cushion cylinder
- 7a: Plunger
- 7b: Plug
- 8: Pressure reducing valve
- 9: Check valve
- 10: Check valve
- 11: Relief valve equipped with the check valve
- 12: Drain valve
- 13: Safety valve
- 14: Air bleeding plug
- 15: Check valve block

**HIC SYSTEM DIAGRAM**

**System diagram**

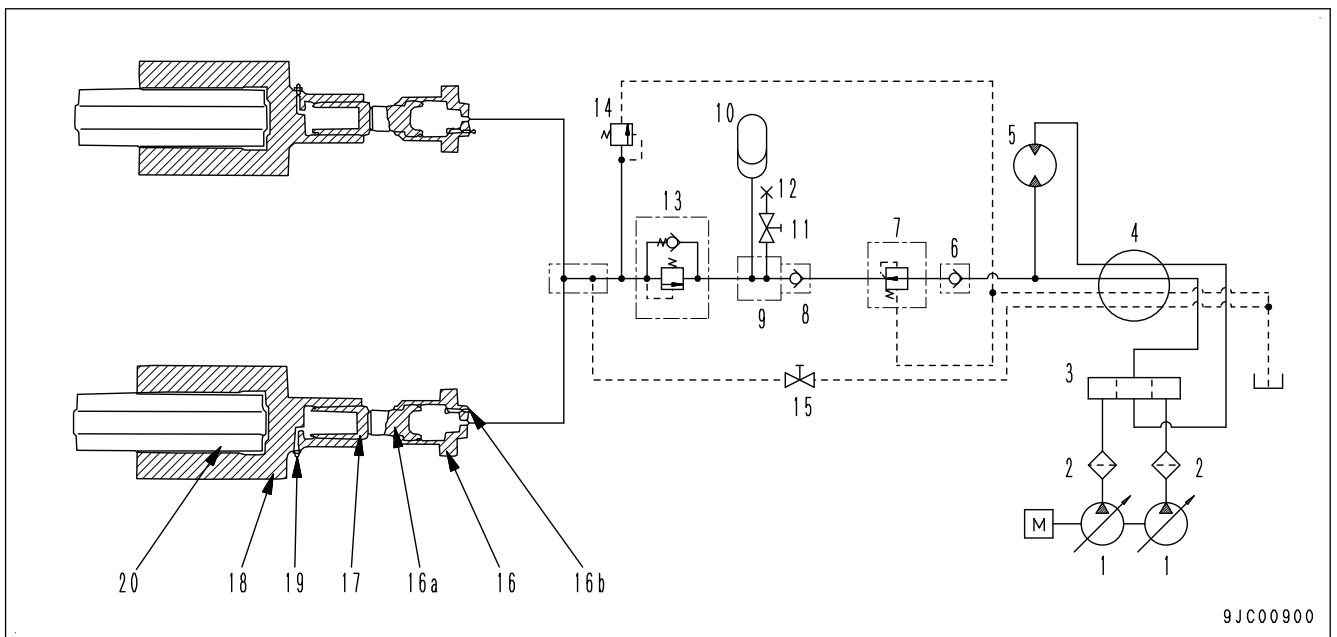

- 1: Hydraulic pump
- 2: Inline filter
- 3: Control valve
- 4: Center swivel joint
- 5: R.H. travel motor
- 6: Check valve
- 7: Pressure reducing valve  
Set pressure: 17.7 MPa {180 kgf/cm<sup>2</sup>}
- 8: Check valve
- 9: Check valve block
- 10: Accumulator
- 11: Air bleeding plug
- 12: Plug
- 13: Relief valve equipped with the check valve  
Cracking pressure: 8.0 MPa {82 kgf/cm<sup>2</sup>}
- 14: Safety valve  
Set pressure: 38.2 MPa {390 kgf/cm<sup>2</sup>}
- 15: Drain valve
- 16: Cushion cylinder
- 16a: Plunger
- 16b: Plug
- 17: Plunger
- 18: Yoke
- 19: Valve
- 20: Idler

**OPERATION OF HIC SYSTEM**

- Oil pressure from the forward travel circuit of the R.H. travel motor (5) is charged into the hydraulic circuit of HIC system via the check valve (6) and the pressure reducing valve (7).
- After pressure the reducing valve (7) reduces the pressure to the set pressure, oil from the R.H. travel motor fills the cushion cylinder (16), and extends the plunger (16a) to the stroke end.

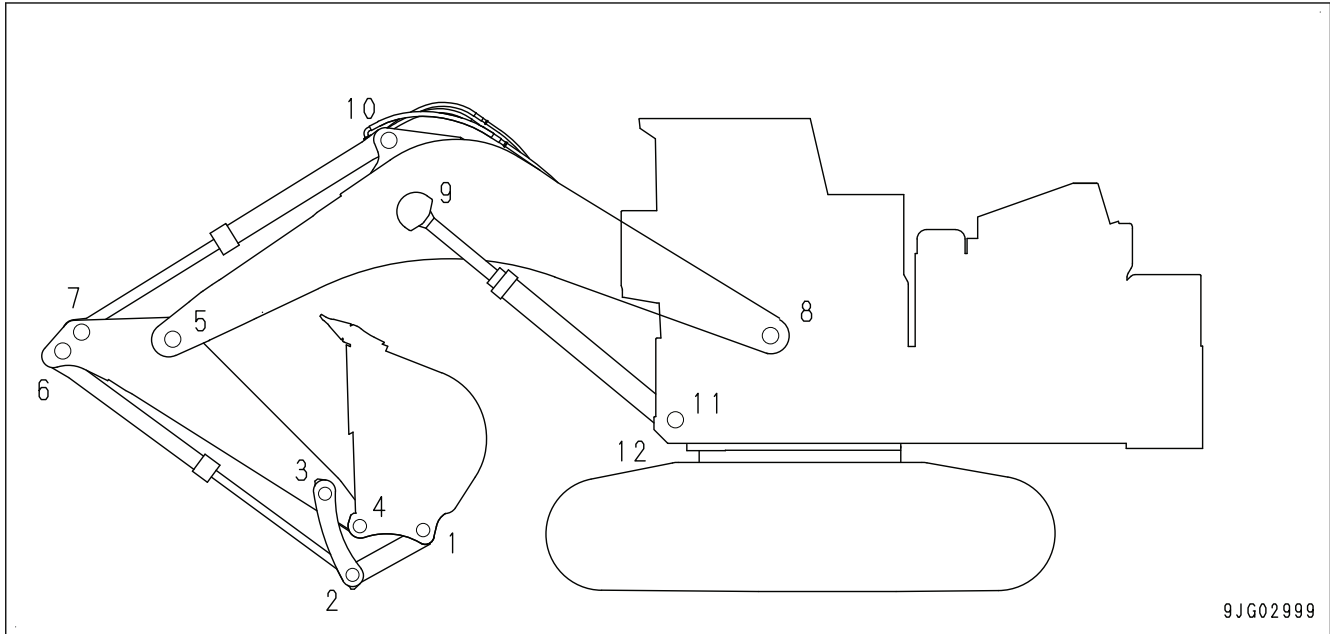

**Injector distribution valve line**

**Backhoe specifications**

	Lubrication points	Discharged volume	
1	Front link + Bucket pin	1.30 cc/rev x 2	
2	Front link + Wrist link	1.30 cc/rev x 4	
3	Arm B boss	1.30 cc/rev x 4	
4	Arm A boss + Bucket pin	1.30 cc/rev x 4	
5	Arm C boss + Boom top pin	Arm	1.30 cc/rev x 2
		Boom	0.72 cc/rev x 2
6	Bucket cylinder bottom pin	0.97 cc/rev x 2	
7	Arm cylinder head pin	1.30 cc/rev x 2	
8	Boom foot pin	0.97 cc/rev x 4	
9	Boom cylinder head pin	1.30 cc/rev x 2	
10	Arm cylinder bottom pin	1.30 cc/rev x 2	
11	Boom cylinder bottom pin	0.13 cc/rev x 2	
12	Swing circle	1.30 cc/rev x 10	

**FUNCTION OF GREASE LUBRICATION SYSTEM**

- Auto greasing function  
When the greasing mode selector switch is at the auto greasing position, the controller operates the grease pump at fixed intervals. When the pump reaches the set pressure, the injector greases each greasing point. The monitor shows the auto greasing operation status of the grease pump.
- Manual greasing function  
When the greasing mode selector switch is at the manual greasing position, the controller operates the grease pump continuously. The monitor shows the manual greasing operation status of the grease pump.
- Remaining grease alarm display function  
If the remaining grease level is low, the controller inputs the low level switch signal, the monitor displays the warning, and the grease caution lamp flashes.

Machine model			PC2000-11	
Engine			SAA12V140E-7	
Item	Measurement condition	Unit	Standard value for new machine	Repair limit
Swing drift on a slope	<ul style="list-style-type: none"> <li>Hydraulic oil temperature 45 to 55 °C</li> <li>Bucket: No load</li> <li>Engine: Stopped</li> <li>Set the machine on 15 ° slope, and set the upper structure sideways.</li> <li>Make match marks on the swing circle outer race and the track frame.</li> <li>Distance that match marks move apart after 5 minutes</li> <li>Measuring posture: See "MACHINE POSTURE AND PROCEDURE FOR MEASURING PERFORMANCE", "Fig. 3".</li> </ul>	mm	0	0
Leakage from swing motor	<ul style="list-style-type: none"> <li>Hydraulic oil temperature 45 to 55 °C</li> <li>Fuel control dial: MAX (High idle) position</li> <li>Swing lock switch: ON</li> <li>Leakage for 1 minute while oil pressure in SWING circuit is relieved</li> </ul>	l/mim	Max. 5	Max. 10

**Traveling**

Machine model			PC2000-11	
Engine			SAA12V140E-7	
Item	Measurement condition	Unit	Standard value for new machine	Repair limit
Travel speed (idle running)	<ul style="list-style-type: none"> <li>Hydraulic oil temperature 45 to 55 °C</li> <li>Working mode: P+ (Power Plus Mode)</li> <li>Fuel control dial: MAX (High idle) position</li> <li>Time required to complete 5 idle turns of track off the ground after 1 idle turn</li> <li>Measuring posture: See "MACHINE POSTURE AND PROCEDURE FOR MEASURING PERFORMANCE", "Fig. 4".</li> </ul>	Sec.	90.5 to 110.5	90.5 to 110.5

14. Operate the work equipment control lever to perform Boom RAISE relief, and measure the change in pressure.

For standard values, see the "Gauge pressure" in STANDARD VALUE TABLE, "STANDARD VALUE TABLE FOR ENGINE".

**REMARK**

- The absolute pressure includes the atmospheric pressure. Check the atmospheric pressure because it changes with altitude.
- The relationship between the absolute pressure and the gauge pressure is as follows.

Gauge pressure = Absolute pressure - Atmospheric pressure

Remove the testing tools and restore the machine after the test is finished.

 Boost pressure pickup plug (6):

Liquid adhesive (LT-2)

 Boost pressure pickup plug (6) :  
2.9 to 5.9 Nm {0.3 to 0.6 kgfm}

## TEST SUPPLY PUMP

- ⚠ Place the machine on a level surface, carefully lower the work equipment to the ground, set the lock lever to LOCK position, and then stop the engine.
- ⚠ Immediately after the engine is stopped, its parts and oil will still be very hot and may cause burn injuries. Wait for the temperature to go down, and then start the work.

Check this item under the following conditions.

Engine coolant temperature: 60 to 100 °C

Refer to this section, if the supply pump is judged to be defective and no other failure is found after performing "TROUBLESHOOTING BY FAILURE CODE (DISPLAY OF CODE)" or "TROUBLESHOOTING OF ENGINE (S MODE)". The test identifies the defective pump (supply pump-L or supply pump-R).

### METHOD FOR TESTING SUPPLY PUMP

1. Open the covers (1) and (2).
2. Start the engine.
3. Select and display the following monitoring items. See "SET AND OPERATE MACHINE MONITOR".

Monitoring code: 17201 "PCV Close Timing (TDC Standard)"

Monitoring code: 31706 "Final Throttle Position"

Monitoring code: 01002 "Engine Speed"

Monitoring code: 04107 "Coolant Temperature"

Monitoring code: 42700 "Engine Oil Temperature"

Monitoring code: 18600 "Inject Fueling Command"

4. Set the engine coolant temperature so that it is within the testing condition range.
5. Set the working mode to P+ ("Power Plus Mode").
6. Turn off the auto-deceleration.
7. Turn the fuel control dial to MAX (High idle) position.
8. Finely operate the swing control lever to check the "PCV Close Timing (TDC Standard)" value and "Engine Speed" when the "Final Throttle Position" value is set to 100 %.

#### REMARK

- Record the results because they will be compared with other measurements later.
  - Operate the swing control lever finely just enough for PPC pressure switch to be turned on. Do not relieve the circuit pressure by this operation.
9. Turn the starting switch to OFF position.
  10. Check that the system operating lamp is not lit.

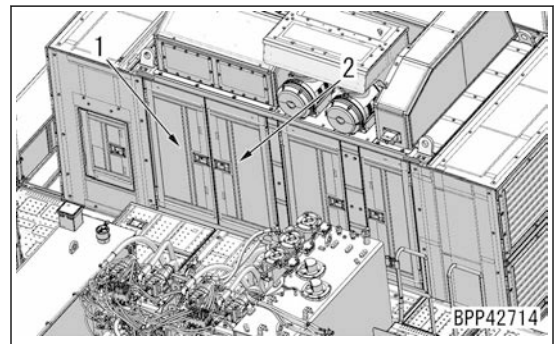

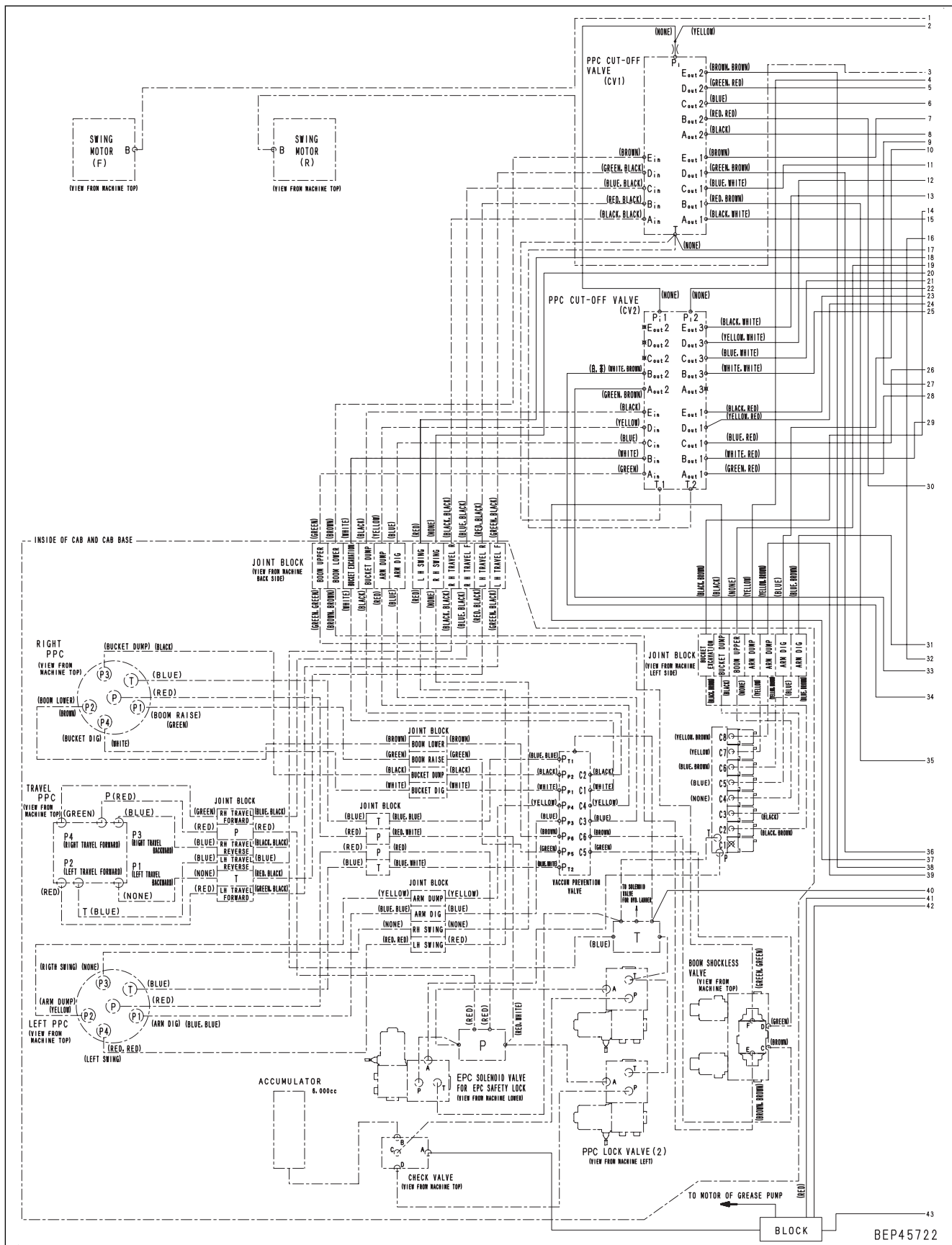

See STANDARD VALUE TABLE, "STANDARD VALUE TABLE FOR MACHINE" for standard values.

Remove the testing tools and restore the machine after the test is finished.

## METHOD FOR TESTING OUTLET PRESSURE OF EPC SOLENOID VALVE OF OIL COOLER FAN PUMP

1. Release the remaining pressure by referring to "RELEASE REMAINING PRESSURE FROM HYDRAULIC SYSTEM".
2. Open the hydraulic pump room inspection cover.
3. Remove the pump discharged pressure pickup port (2), and attach the nipple C and O-ring D.

(2): Radiator fan pump EPC solenoid output pressure pick-up port (PMF)

4. Connect the gauge A1 in hydraulic tester A.

### REMARK

Gauge in the digital hydraulic tester B can also be used instead of the gauge A1.

5. Start the engine.
6. Select "Fan Speed Mode Select" from the adjustment menu of the service mode, and set the fan speed to 100 % by referring to "SET AND OPERATE MACHINE MONITOR".
7. Select "Pre-defined Monitoring" (01/39) or the following monitoring item, and display it by referring to "SET AND OPERATE MACHINE MONITOR".

Monitoring code: 04401 "Hydraulic Oil Temperature"

8. Adjust the hydraulic oil temperature so that it is within the specified range.
9. Run the engine with the fuel control dial in MAX (High idle) position, and test the O/C fan pump EPC solenoid valve outlet pressure.

See STANDARD VALUE TABLE, "STANDARD VALUE TABLE FOR MACHINE" for standard values.

Remove the testing tools and restore the machine after the test is finished.

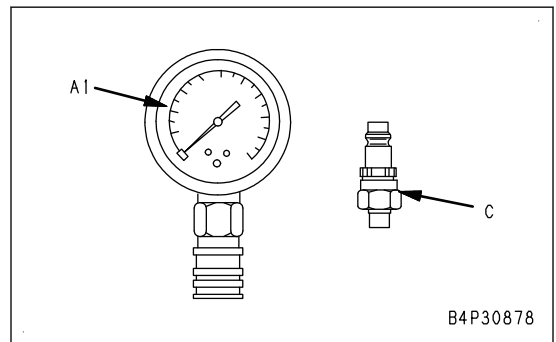
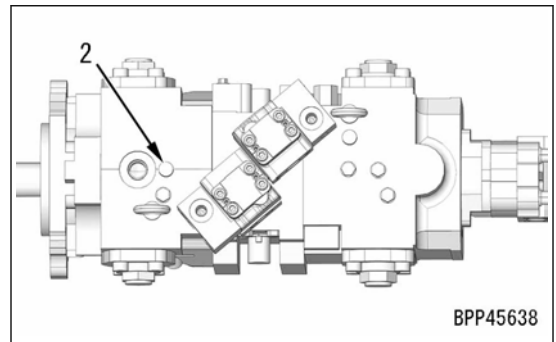

### CHECKING FUNCTION BY LCD (LIQUID CRYSTAL DISPLAY)

If the following operation is performed with the numeral input and function switches while the standard screen is displayed, the LCD screen will turn completely white.

Switch operation (simultaneous): 4 + F2

- When ending switch operation, first release a finger from the F2 switch.
- If a display error is indicated on the LCD (liquid crystal display), only its part is displayed in black.
- If any function switch is pressed, the display returns to the original screen.

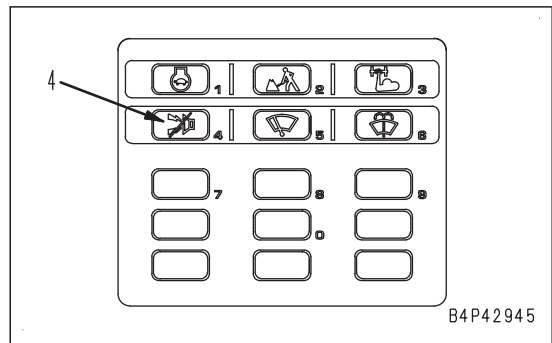
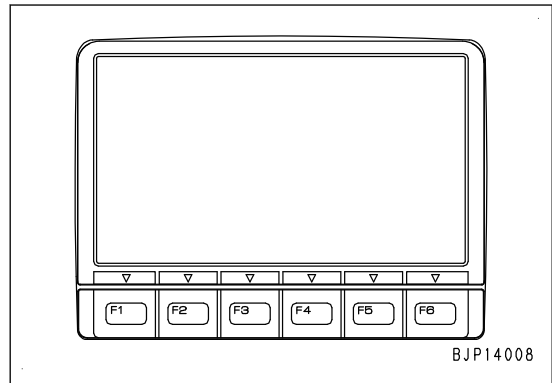

### CHECKING FUNCTION OF SERVICE METER

When checking the service meter while the starting switch is turned to OFF position, perform the following operation using the numeral input switches; only the service meter section will be displayed.

Switch operation (simultaneous): 4 + 1

#### REMARK

- A slight time lag occurs when opening the LCD (liquid crystal display) monitor. Hold down the switches until the screen is displayed.
- If either switch is released, the monitor is turned off.

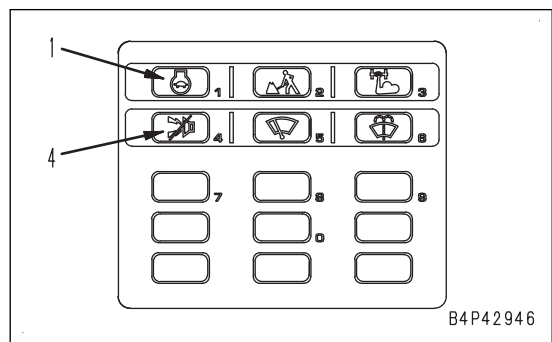
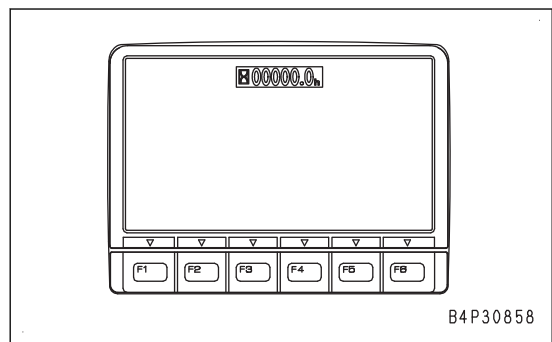

### METHOD FOR SETTING USAGE LIMITATION AND CHANGING PASSWORD

A password can be set for an user limitation setting of the machine monitor. Password input screen appears when resetting the maintenance items once the password is set.

For the operation method of "Operator ID Change", see "Operation and Maintenance Manual".

Observe the following procedure when setting the usage limitation or changing the password.

6. Select one of the maintenance items. When the individual maintenance item screen is displayed, select "On or Off Setting".

F3: Moves the selection downward

F4: Moves the selection upward

F5: Selection is canceled. The screen returns to "Maintenance Mode Change" screen.

F6: Enters the selected item. The screen returns to "ON" or "OFF" screen of the individual maintenance items.

**REMARK**

This is an example of the displayed screen of the "Engine Oil Change Interval".

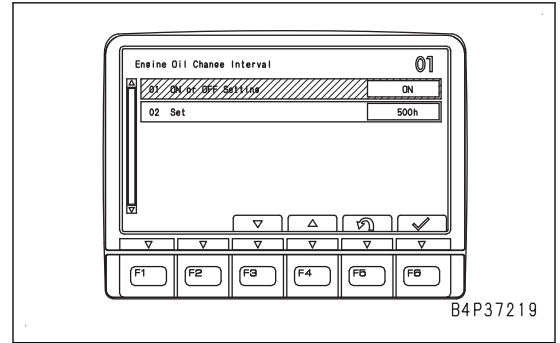

B4P37219

7. On the individual maintenance item screen, select "ON" or "OFF" with the function switches.

"ON": Function of the particular maintenance item becomes enabled in operator mode.

"OFF": Function of the particular maintenance item becomes ineffective in operator mode.

F3: Moves the selection downward

F4: Moves the selection upward

F5: Selection is canceled. The screen returns to the individual maintenance item screen.

F6: Enters the selection. The screen returns to the individual maintenance item screen.

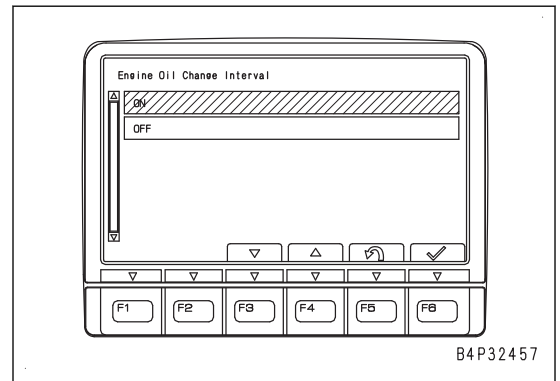

B4P32457

8. Select "Set" of the individual maintenance item. Set the maintenance time using the function switches on the appeared screen.

Default: Maintenance set time set in the machine monitor (Recommended value by the manufacturer. This is not changeable).

Set: Maintenance notice time that can be freely set. Maintenance reminder function works according to this set time in operator mode (the time can be increased or decreased in multiples of 25 h).

F3: Decreases the set value.

F4: Increases the set value.

F5: Contents of setting is canceled. The screen returns to the "Maintenance Mode Change" screen.

F6: Enters the setting and returns the screen to the "Maintenance Mode Change" screen.

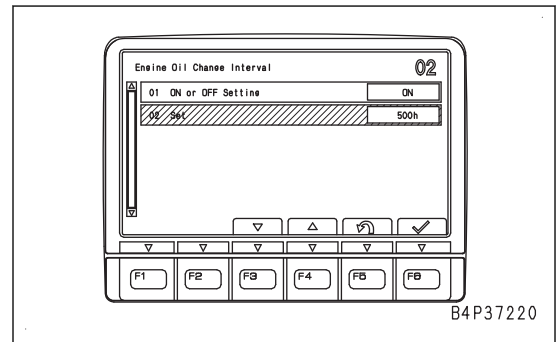

B4P37220

**REMARK**

- Press F6 to enter the setting. The screen returns to "Maintenance Mode Setting", and the setting is enabled.
- If the value of an item which is set to "ON" is changed after one operating hour or more from the setup, the change is recognized as a reset operation.

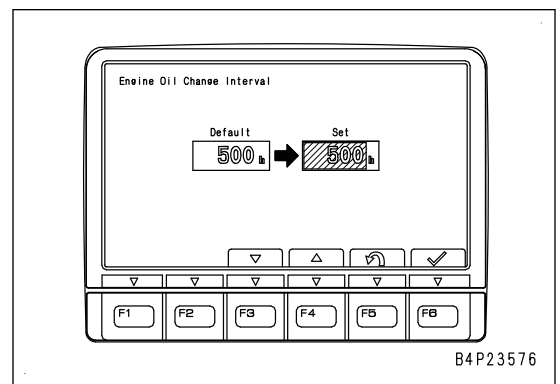

B4P23576

- When the “Pump 1 I-q Automatic Calibration” screen is displayed, select “Restore to Factory Setting” using the function switch or numeral input switch.

**REMARK**

For selecting method, see “METHOD FOR OPERATING SERVICE MODE” in “SERVICE MODE”.

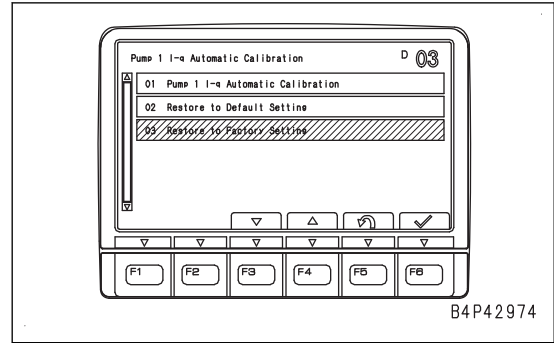

- Pressing F6 returns to the factory setting. When F6 is pressed, the “Pump 1 I-q Automatic Calibration” screen appears. When “F” appears in the top right corner of the screen, it indicates that the setting has been returned to the factory setting.

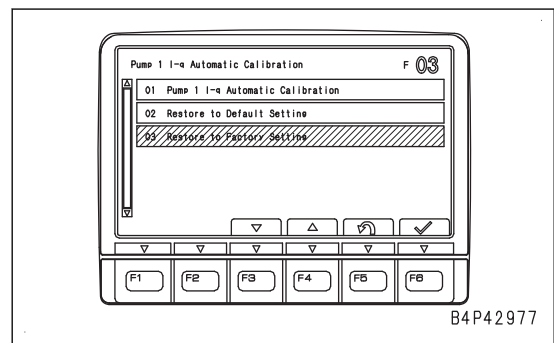
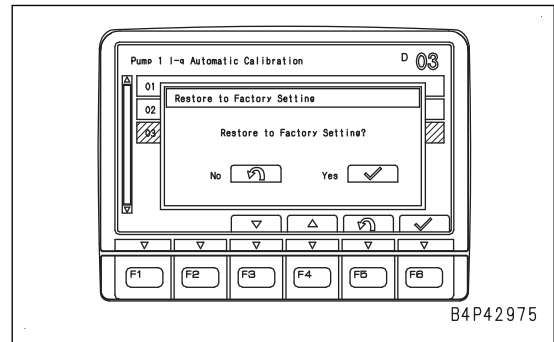

**METHOD FOR ADJUSTING WITH ADJUSTMENT MENU (Pump 2 I-q Automatic Calibration)**

Use the adjustment menu to check the various settings of the machine or to adjust the value.

- Select “Adjustment” on “Service Menu” screen.

**REMARK**

For selecting method, see “METHOD FOR OPERATING SERVICE MODE” in “SERVICE MODE”.

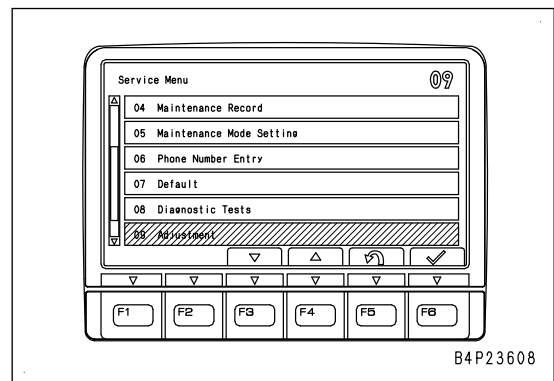

# Pm CLINIC

## Pm CLINIC SERVICE

Machine model	Serial number	Service meter
<input type="checkbox"/> P2000-11		h
User name	Date of inspection	Inspector
	/ /	

Specifications	
Main parts	Shoe width
<input type="checkbox"/> Boom, standard <input type="checkbox"/> (                    )	<input type="checkbox"/> 810 mm (Double) <input type="checkbox"/> (                    )
<input type="checkbox"/> Arm, standard <input type="checkbox"/> (                    )	<input type="checkbox"/> 1010 mm (Triple)
<input type="checkbox"/> Bucket, standard <input type="checkbox"/> (                    )	

Operating condition		
Quarry, Mining	Construction	Type of soil
<input type="checkbox"/> Coal	<input type="checkbox"/> Construction, civil engineering	<input type="checkbox"/> Rock
<input type="checkbox"/> Gold	<input type="checkbox"/> Road	<input type="checkbox"/> Gravel
<input type="checkbox"/> Limestone	<input type="checkbox"/> Tunnel	<input type="checkbox"/> Sand
<input type="checkbox"/>	<input type="checkbox"/>	<input type="checkbox"/> Clay

Check of oil and coolant levels		
<input type="checkbox"/> Radiator coolant	When necessary	
<input type="checkbox"/> Engine oil	<input type="checkbox"/> PTO gear case oil	<input type="checkbox"/> Machinery case oil
<input type="checkbox"/> Hydraulic oil	<input type="checkbox"/> Final drive case oil	<input type="checkbox"/> (                    )

Outside air temperature	Altitude
°C	m

Operator's comment
Result of visual inspection

H-35 UPPER STRUCTURE OVERRUNS EXCESSIVELY WHEN IT STOPS SWINGING (BOTH RIGHT AND LEFT).....40-1382

H-36 UPPER STRUCTURE OVERRUNS EXCESSIVELY WHEN IT STOPS SWINGING (ONLY ONE DIRECTION EITHER RIGHT OR LEFT) .....40-1383

H-37 SHOCK IS LARGE WHEN UPPER STRUCTURE STOPS SWINGING (BOTH RIGHT AND LEFT) .....40-1384

H-38 SHOCK IS LARGE WHEN UPPER STRUCTURE STOPS SWINGING .....40-1385

H-39 LARGE UNUSUAL NOISE IS HEARD WHEN UPPER STRUCTURE STOPS SWINGING (BOTH RIGHT AND LEFT).....40-1386

H-40 LARGE UNUSUAL NOISE IS HEARD WHEN UPPER STRUCTURE STOPS SWINGING IN ONLY ONE DIRECTION .....40-1387

H-41 SWING DRIFT ON A SLOPE IS LARGE .....40-1388

H-42 FAN SPEED IS ABNORMAL (SUCH AS EXCESSIVE NOISE OR VIBRATION OF FAN, OR OVERHEATING) .....40-1389

TRUBLESHOOTING OF ENGINE (S-MODE) .....40-1390

INFORMATION MENTIONED IN TROUBLESHOOTING TABLE (S MODE).....40-1390

S-1 ENGINE DOES NOT CRANK WHEN STARTING SWITCH IS TURNED TO .....40-1391

S-2 ENGINE CRANKS BUT NO EXHAUST GAS COMES OUT .....40-1392

S-3 FUEL IS BEING INJECTED BUT ENGINE DOES NOT START (MISFIRING:ENGINE CRANKS BUT DOES NOT START) .....40-1393

S-4 ENGINE STARTABILITY IS POOR.....40-1394

S-5 ENGINE DOES NOT PICK UP SMOOTHLY .....40-1396

S-6 ENGINE STOPS DURING OPERATION .....40-1398

S-7 ENGINE RUNS ROUGH OR IS UNSTABLE .....40-1400

S-8 ENGINE LACKS POWER.....40-1401

S-9 KDPF GETS CLOGGED IN A SHORT TIME .....40-1403

S-10 ENGINE OIL CONSUMPTION IS EXCESSIVE .....40-1405

S-11 OIL BECOMES CONTAMINATED QUICKLY .....40-1406

S-12 FUEL CONSUMPTION IS EXCESSIVE .....40-1407

S-13 OIL IS IN COOLANT (OR COOLANT SPURTS BACK OR COOLANT .....40-1408

S-14 OIL PRESSURE DROPS .....40-1409

S-15 FUEL MIXES INTO ENGINE OIL.....40-1411

S-16 WATER MIXES INTO ENGINE OIL (MILKY) .....40-1412

S-17 COOLANT TEMPERATURE RISES TOO HIGH (OVERHEATING) .....40-1413

S-18 UNUSUAL NOISE IS HEARD.....40-1415

S-19 VIBRATION IS EXCESSIVE .....40-1416

S-20 AIR CANNOT BE BLED FROM FUEL CIRCUIT .....40-1417

S-21 ACTIVE REGENERATION IS EXECUTED FREQUENTLY .....40-1418

S-22 ACTIVE REGENERATION TAKES TIME.....40-1419

S-23 WHITE SMOKE IS EXHAUSTED DURING ACTIVE REGENERATION.....40-1420

- 1) Remove the caps from the top of battery. (described before)
- 2) Look into the fluid filler port (3) and check the electrolyte level. If the electrolyte does not reach the sleeve (4), always add the purified water (example: commercially available battery fluid, etc.) so that the level reaches the bottom of the sleeve (UPPER LEVEL line).
  - (A) Correct level: Since the electrolyte level reaches to the sleeve bottom, the shape of the electrode plates will appear distorted due to the surface tension.
  - (B) Low level: Electrolyte level does not reach the bottom of sleeve, so electrode plates appear straight and not bent.
- 3) After adding, tighten the cap.

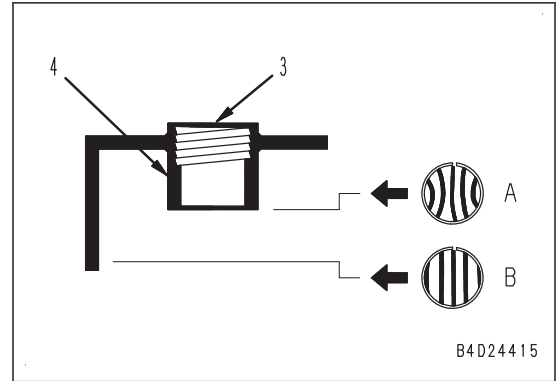

#### NOTICE

If purified water is added to above the UPPER LEVEL (U.L.) line, use a syringe to lower the level to the UPPER LEVEL (U.L.) line. Neutralize the removed fluid with baking soda (sodium bicarbonate), and then flush it away with a large amount of water.

#### Check of wiring harness for discoloration, burn and cover peeling

7. Check the wiring harness and cables for discoloration and burn.

**⚠ If discolored or burnt, the circuit may be shorted or grounded.**

- Check the wiring harnesses and cables for damage and peeling of the covers.
- If any abnormality is found, repair or replace the wiring harness or cables.

#### Check for coming off of wiring harness clamp and sagging of wiring harness

8. Check wiring harness for sagging and looseness due to coming off of harness clamp.

#### REMARK

In particular, carefully check the wiring harness around the hot and movable parts. If removed from the clamp, secure it with the clamp.

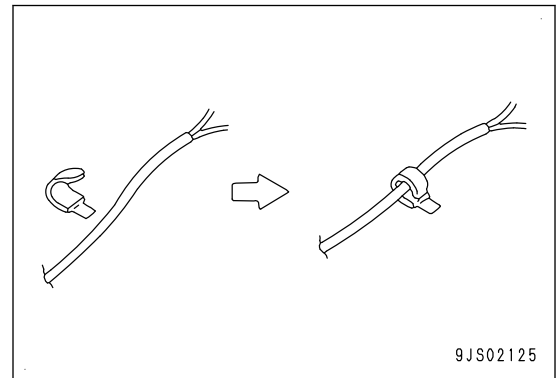

#### Check of grounding

9. Check the connecting state of each ground terminal.
  - Check the mounting bolts and nuts for looseness.
  - Check the contact face between the ground terminal (1) and mounting place of machine body for sticking of the insulator such as foreign material, etc. Battery ground cable is shown in the figure as an example.
  - For the position of each ground, see "CONNECTORS LIST AND LAYOUT".

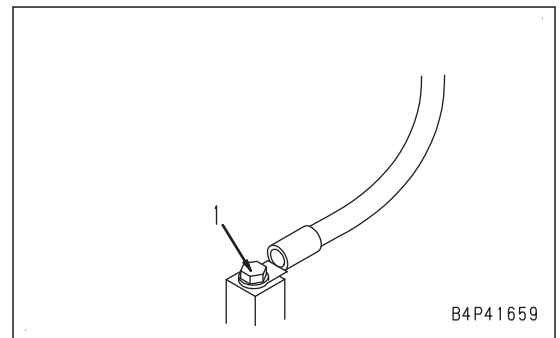

#### Check of connector for looseness and lock for damage

10. Check the connection of male and female connectors by pulling them by hand.

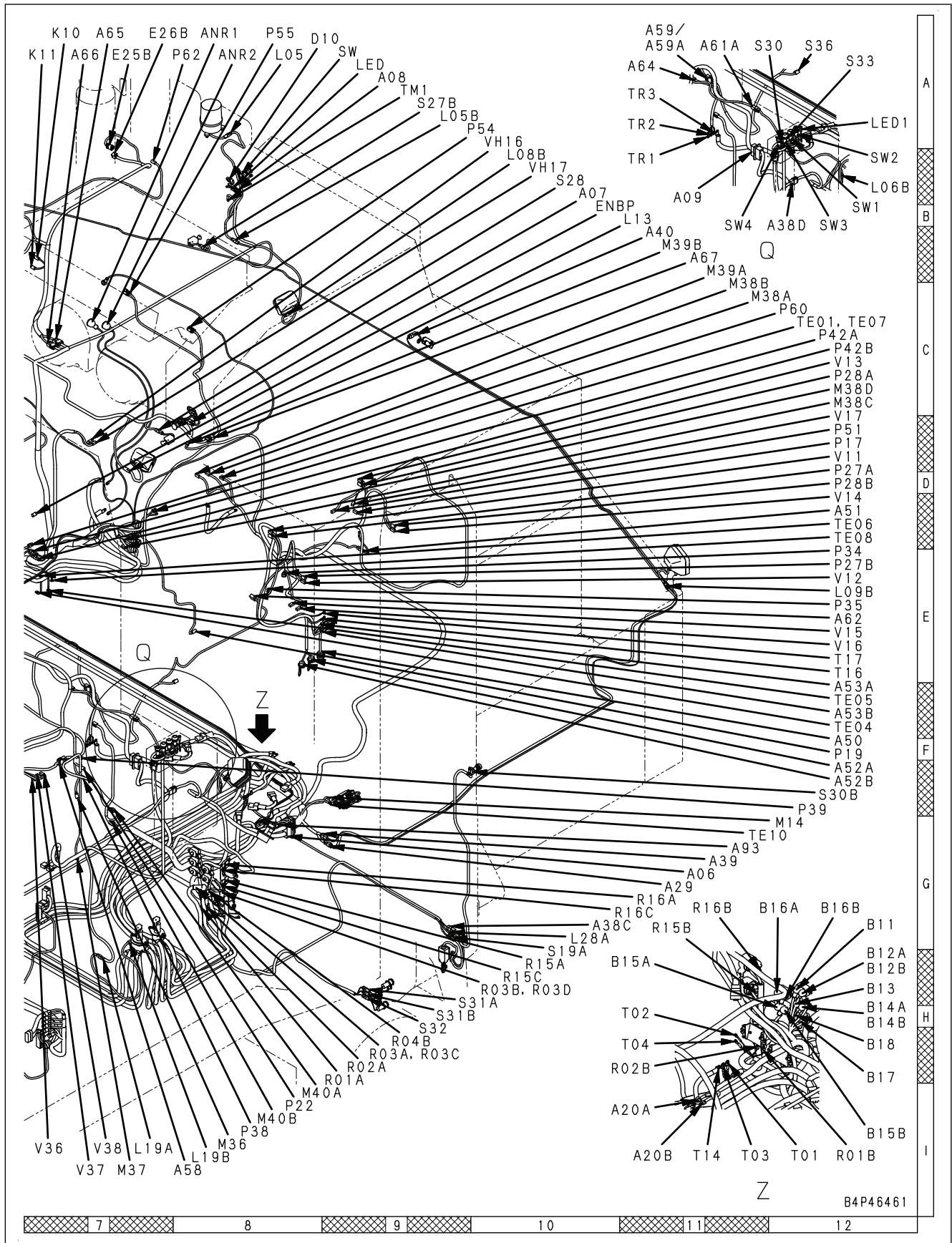

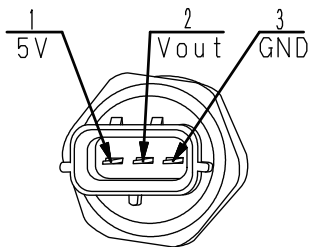
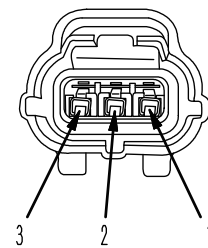
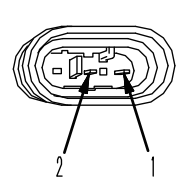
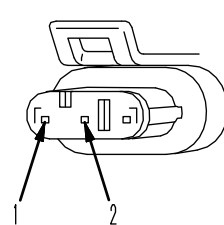
AMP connelor for engine			
No. of pins	Common rail (fuel) pressure sensor (95, 125, 140 engine)		
	Sensor side (plue)	Harness side (receptacle)	Testing connection use special tool Part No.
3			799-601-9420 (T-adapter) (kit:799-601-4101) (kit:799-601-4201)
	—	—	
No. of pins	Turbocharger speed sensor (107, 114 engine)		
	Sensor side (plue)	Harness side (receptacle)	Testing connection use special tool Part No.
3			799-601-4660 (Socket) (kit:799-A65-4600)
	☆ Without pin (3)	☆ Without pin (3)	

B4W21625

Failure code	Failure (displayed on screen)	Applicable equipment	Action level	History category	Remarks
CB2271	EGR Valve Position Sensor High Error_2	ENG	L03	Electrical system	
CB2272	EGR Valve Position Sensor Low Error_2	ENG	L03	Electrical system	
CB2349	EGR Valve Solenoid Open Circuit Error_2	ENG	L03	Electrical system	
CB2353	EGR Valve Solenoid Short Circuit Error_2	ENG	L03	Electrical system	
CB2357	EGR Valve Servo Error_2	ENG	L03	Electrical system	
CB2381	VGT Position Sensor High Error_2	ENG	L03	Electrical system	
CB2382	VGT Position Sensor Low Error_2	ENG	L03	Electrical system	
CB2383	VGT Solenoid Open Circuit Error_2	ENG	L03	Electrical system	
CB2386	VGT Solenoid Short Circuit Error_2	ENG	L03	Electrical system	
CB2387	KGT Servo Error_2	ENG	L03	Electrical system	
CB2637	KDOC Face Plugging_2	ENG	L01	Electrical system	
CB2639	Manual Stationary Regeneration Request_2	ENG	L01	Electrical system	
CB2732	Fuel Doser Solenoid 2 High Error_2	ENG	L03	Electrical system	
CB2733	Fuel Doser Solenoid 2 Low Error_2	ENG	L03	Electrical system	
CB2741	Fuel Dozer Solenoid Valve Swap Error_2	ENG	L03	Electrical system	
CB2777	Manual Stationary Regeneration Request but KDPF Regeneration Disable_2	ENG	-	Electrical system	
CB2878	Fuel Doser Solenoid 2 Servo Error_2	ENG	L03	Electrical system	
CB2881	Dosing Fuel Pressure Low Error 1_2	ENG	L03	Electrical system	
CB3133	KDPF Outlet Pressure Sensor High Error_2	ENG	L03	Electrical system	
CB3134	KDPF Outlet Pressure Sensor Low Error_2	ENG	L03	Electrical system	
CB3135	KDPF Outlet Pressure Sensor In Range Error_2	ENG	L03	Electrical system	
CB3167	Fuel Doser Degradation_2	ENG	-	Electrical system	
CB3251	KDOC Inlet Temperature High Error_2	ENG	L03	Electrical system	

**FAILURE CODE [B@HAZK]**

Action level	Failure code	Failure	Low hydraulic oil level (Machine monitor system)
L03	B@HAZK		
Detail of failure	Machine monitor detected a decrease in hydraulic oil level.		
Action of controller	None in particular		
Phenomenon on machine	If machine is used as it is, peripheral equipment of the work equipment circuit may be damaged.		
Related information	After completion of repair, check with following operation that the failure code is cleared. Procedure: Turn the starting switch to ON position.		

No.	Cause	Procedure, measuring location, criteria and remarks	
1	Low hydraulic oil level (when system is normal)	Since the hydraulic oil level may be low, check it and refill oil.	
2	Defective hydraulic oil level switch	1. Turn the starting switch to OFF position. 2. Disconnect the connector P39, and connect the T-adapter to male side. 3. Turn the starting switch to ON position.	
		Resistance	Between P39 (male) (1) and (2)
3	Open circuit in wiring harness	1. Turn the starting switch to OFF position. 2. Disconnect the connectors CP06 and P39, and connect the T-adapter to either female side.	
		Resistance	Between ground and CP06 (female) (9) or P39 (female) (1)
4	Defective pump controller	If no failure is found by above checks, pump controller is defective. (Since this is an internal defect, troubleshooting cannot be performed).	

**Circuit diagram related to hydraulic oil level**

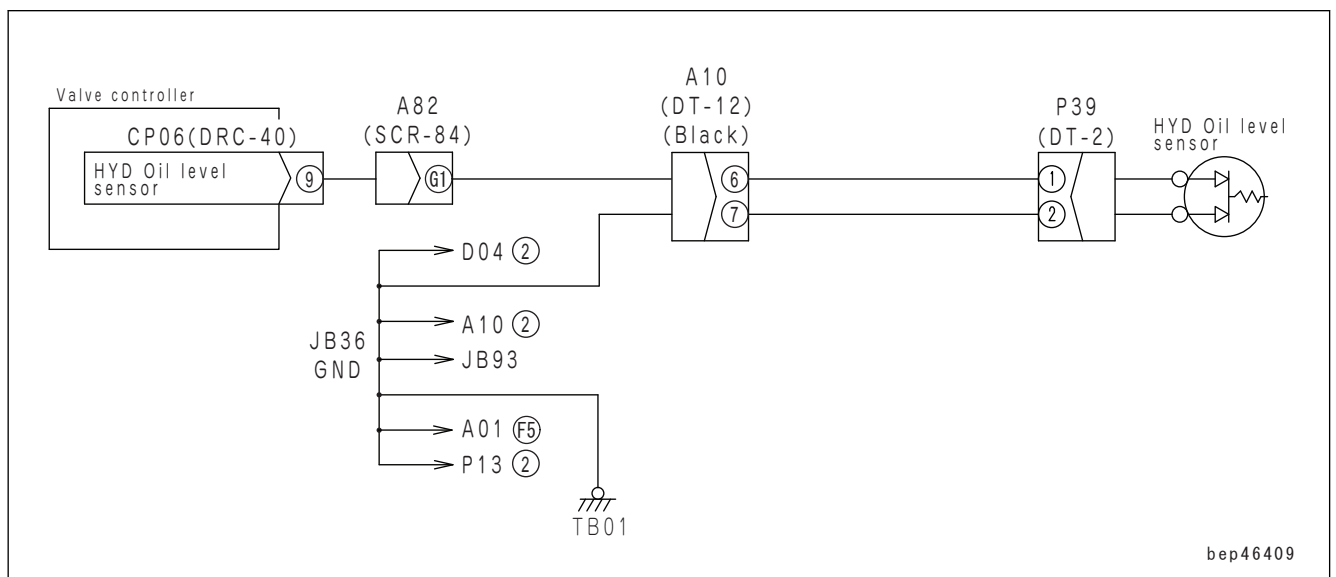

**FAILURE CODE [CA234]**

Action level	Failure code	Failure	Engine Overspeed (Engine controller system)
L02	CA234		
Detail of failure	Engine speed exceeds operating range.		
Action of controller	Restricts fuel injection rate until speed is lowered within operating range.		
Phenomenon on machine	Engine speed varies.		
Related information	<ul style="list-style-type: none"> <li>• If other failure code is also displayed at the same time, perform troubleshooting for that code first.</li> <li>• Engine speed can be checked by monitoring. (Code: 01002)</li> <li>• After completion of repair, check with following operation that the failure code is cleared. Procedure: Start the engine and run it at high idle.</li> </ul>		

No.	Cause	Procedure, measuring location, criteria and remarks
1	Incorrectly-used fuel	Perform checks since incorrect fuel may be used.
2	Incorrect machine usage	The mounted machine may be used incorrectly, instruct to use it correctly.
3	Defective engine controller	If no failure is found by preceding checks, engine controller is defective. (Since this is an internal defect, troubleshooting cannot be performed.)

**FAILURE CODE [CA386]**

Action level	Failure code	Failure	HC Desorb Request 1 (Engine controller system)
L03	CA386		
Detail of failure	High voltage occurs in sensor 1 power supply (5 V) circuit.		
Action of controller	<ul style="list-style-type: none"> <li>• Ignores signal from Bkup speed sensor, and operates by NE speed sensor signal.</li> <li>• Ignores signal from engine oil pressure sensor, and sets the oil pressure at fixed value (250 kPa {2.5 kgf/cm<sup>2</sup>}) and runs engine.</li> <li>• Ignores signal from ambient pressure sensor, and sets the ambient pressure at fixed value (52.44 kPa {0.53 kgf/cm<sup>2</sup>}) and runs engine.</li> <li>• Ignores signal from charge (boost) pressure sensor, and sets the charge (boost) pressure at fixed value (400 kPa {4.1 kgf/cm<sup>2</sup>}) and runs engine.</li> <li>• Ignores signal from crankcase pressure sensor, and sets the crankcase pressure at fixed value (0 kPa {0 kgf/cm<sup>2</sup>}) and runs engine.</li> <li>• Closes EGR valve and fully opens VGT (failed side).</li> <li>• Engine power deration.</li> <li>• Stops regeneration control.</li> </ul>		
Phenomenon on machine	Engine output is reduced.		
Related information	<ul style="list-style-type: none"> <li>• Connectors of electrical parts around engine may be defective due to heat and vibration. See "RELATED INFORMATION ON TROUBLESHOOTING", "CHECKS BEFORE TROUBLESHOOTING", "Electrical equipment", and check them according to the descriptions of wiring harness and connectors.</li> <li>• Engine power deration is canceled by turning the starting switch to OFF position after this failure code is cleared. (This deration is not canceled by simply failure code being cleared.)</li> <li>• After completion of repair, check with following operation that the failure code is cleared. Procedure: Turn the starting switch to ON position.</li> </ul>		

No.	Cause	Procedure, measuring location, criteria and remarks		
1	Defective sensor or wiring harness	1. Turn the starting switch to OFF position. 2. Disconnect following connectors one by one, and turn the starting switch to ON position each time. 3. After troubleshooting for one connector, return to step 1, and proceed to the next connector.  If this failure code is cleared, disconnected sensor or engine wiring harness is defective.  <b>REMARK</b> Many other failure codes are also displayed at the same time. This is because connector is disconnected. Ignore failure codes other than this failure code.		
		Connector	Bkup speed sensor	G_L
			Oil pressure sensor	POIL
			Charge (boost) pressure sensor	PIM_L
			Ambient pressure sensor	PAMB
			Crankcase pressure sensor	PCCV_L
			Engine wiring harness	ECM_L_J1

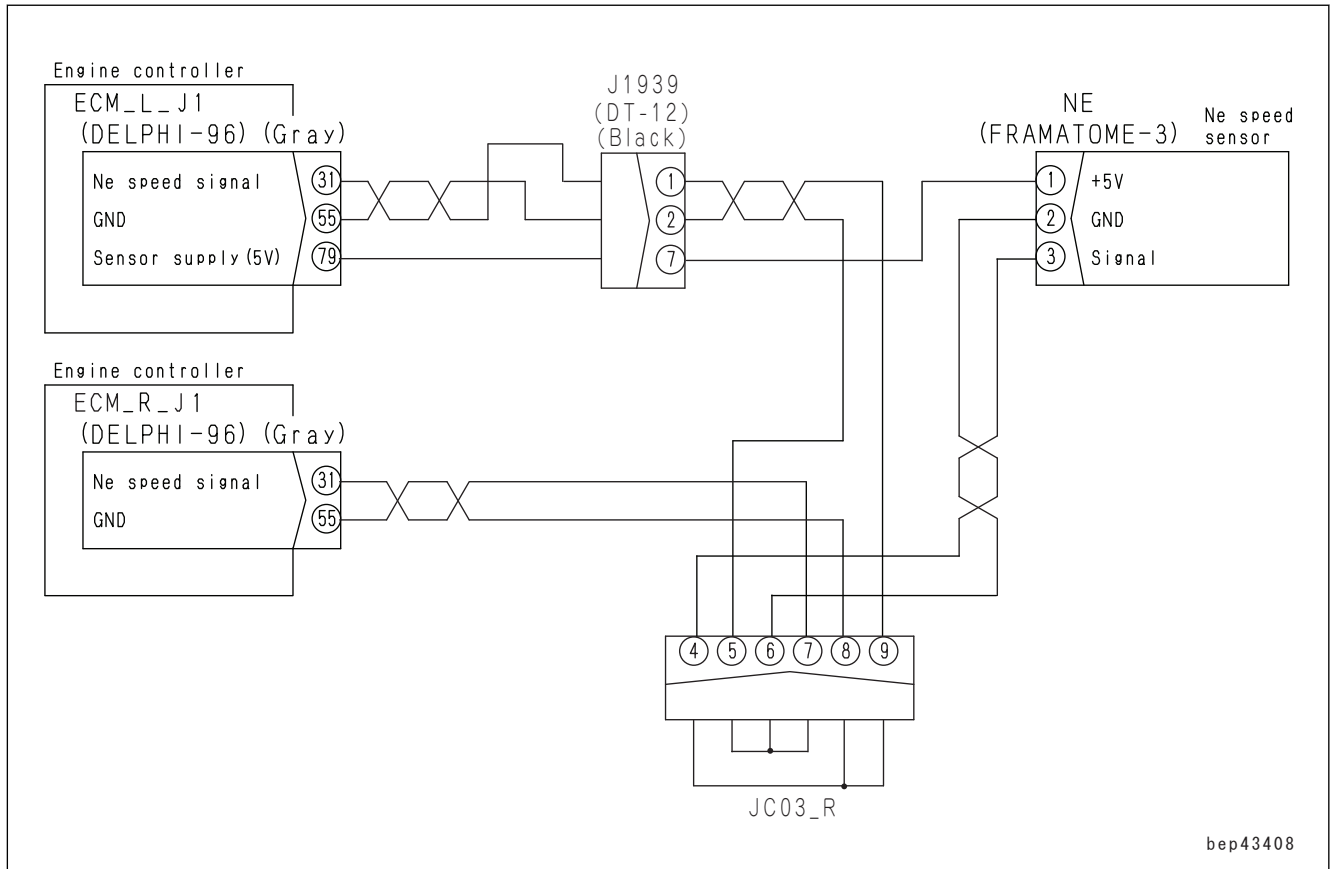

### Circuit diagram related to fuel doser solenoid valve

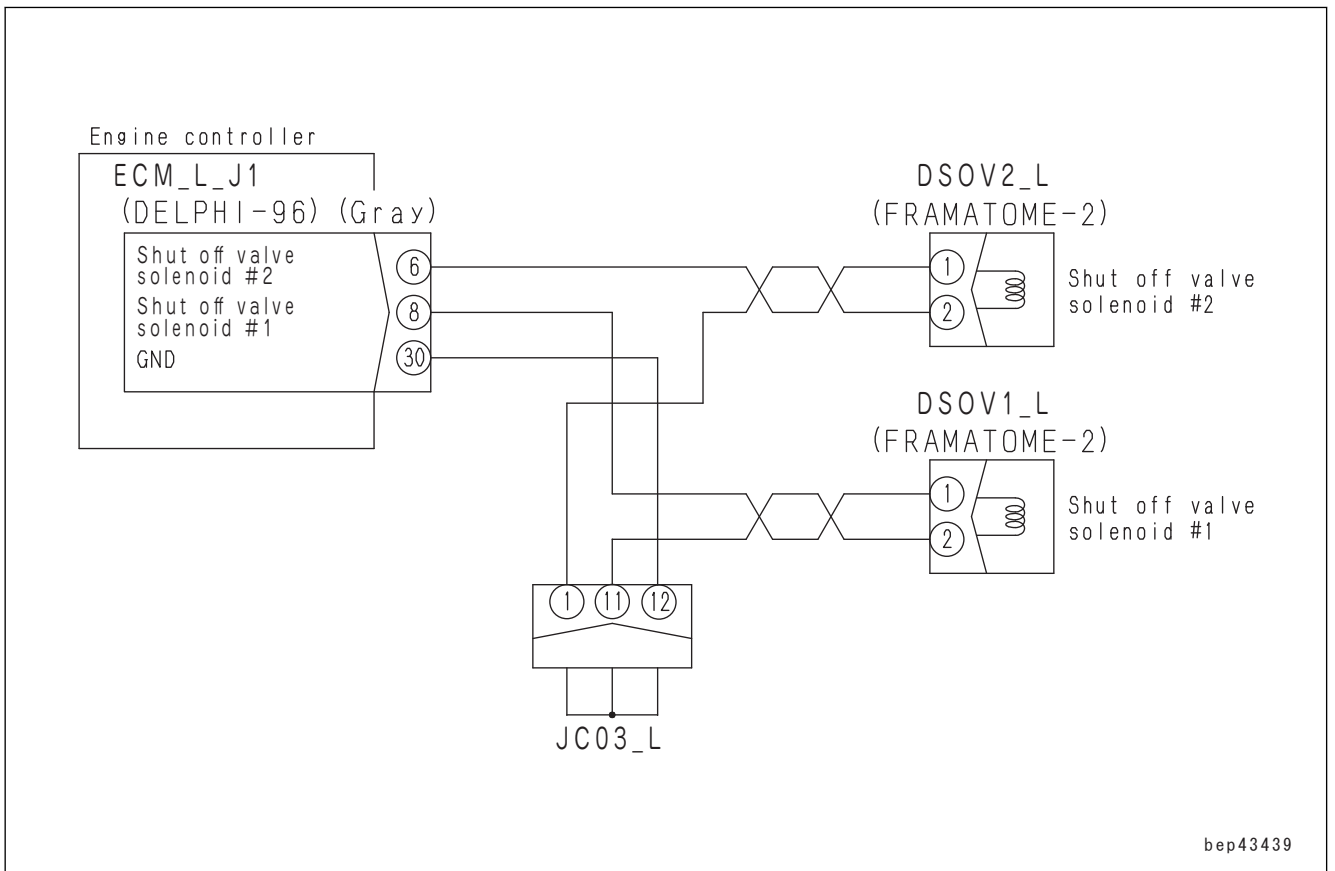

No.	Cause	Procedure, measuring location, criteria and remarks		
7	Open circuit in wiring harness	1. Turn the starting switch to OFF position. 2. Disconnect the connectors ECM_L_J1 and SEGR_L, and connect the T-adapter to female side of each connector.		
		Resistance	Between ECM_L_J1 (female) (81) and SEGR_L (female) (1)	Max. 1 Ω
			Between ECM_L_J1 (female) (57) and SEGR_L (female) (2)	Max. 1 Ω
			Between ECM_L_J1 (female) (88) and each of SEGR_L (female) (3) and (4)	Max. 1 Ω
8	Ground fault in wiring harness	1. Turn the starting switch to OFF position. 2. Disconnect the connectors ECM_L_J1 and SEGR_L, and connect the T-adapter to either female side.		
		Resistance	Between ground and ECM_L_J1 (female) (88) or SEGR_L (female) (3)	Min. 1 MΩ
9	Hot short circuit in wiring harness	1. Turn the starting switch to OFF position. 2. Disconnect the connector SEGR_L, and connect the T-adapter to female side. 3. Turn the starting switch to ON position.		
		Voltage	Between SEGR_L (female) (3) or (4) and (2)	Max. 1 V
10	Short circuit in wiring harness	1. Turn the starting switch to OFF position. 2. Disconnect the connectors ECM_L_J1 and SEGR_L, and connect the T-adapter to either female side.		
		Resistance	Between ECM_L_J1 (female) (81) and (88), or between SEGR_L (female) (1) and (3), or between SEGR_L (female) (1) and (4)	No continuity
			Between ECM_L_J1 (female) (88) and (57), or between SEGR_L (female) (2) and (3)	No continuity
11	Defective EGR valve lift sensor	1. Turn the starting switch to OFF position. 2. Insert the T-adapter into connector SEGR_L. 3. Turn the starting switch to ON position.		
		Voltage	Between SEGR_L (3) and (2)	1.0 to 4.0 V
12	Defective engine controller	If no failure is found by preceding checks, engine controller is defective. (Since this is an internal defect, troubleshooting cannot be performed.)		

**FAILURE CODE [CA3134]**

Action level	Failure code	Failure	HC Desorb Request 1 (Engine controller system)
L03	CA3134		
Detail of failure	Low voltage is generated in signal circuit of KDPF outlet pressure sensor.		
Action of controller	Drives the value of KDPF differential pressure sensor at an estimated value (gauge pressure). (If another failure code is also displayed at the same time, controller may set it to 0 kPa (gauge pressure) and runs engine.)		
Phenomenon on machine	None in particular		
Related information	<ul style="list-style-type: none"> <li>Connectors of electrical parts around engine may be defective due to heat and vibration. See "RELATED INFORMATION ON TROUBLESHOOTING", "CHECKS BEFORE TROUBLESHOOTING", "Electrical equipment", and check them according to the descriptions of wiring harness and connectors.</li> <li><b>⚠ KDPF is heated to Min. 500 °C. Be careful not to get burn injury.</b></li> <li>If failure code [CA1695] or [CA1696] is displayed, sensor power supply system may be defective. Perform troubleshooting for [CA1695] or [CA1696] first.</li> <li>Signal voltage detected by KDPF outlet pressure sensor can be checked by monitoring. (Code: 47001)</li> <li>Differential pressure detected by KDPF outlet pressure sensor can be checked by monitoring. (Code: 47000)</li> <li>After completion of repair, check with following operation that the failure code is cleared. Procedure: Turn the starting switch to ON position.</li> </ul>		

No.	Cause	Procedure, measuring location, criteria and remarks		
1	Open circuit in wiring harness	1. Turn the starting switch to OFF position. 2. Disconnect the connectors ECM_L_J2 and E25A, and connect the T-adapter to each female side.		
		Resistance	Between ECM_L_J2 (female) (32) and E25A (female) (1)	Max. 1 Ω
			Between ECM_L_J2 (female) (8) and E25A (female) (4)	Max. 1 Ω
			Between ECM_L_J2 (female) (41) and E25A (female) (2)	Max. 1 Ω
2	Ground fault in wiring harness	1. Turn the starting switch to OFF position. 2. Disconnect the connectors ECM_L_J2 and E25A, and connect T-adapter to either female side.		
		Resistance	Between ground and ECM_L_J2 (female) (42) or E25A (female) (3)	Min. 1 MΩ
3	Short circuit in wiring harness	1. Turn the starting switch to OFF position. 2. Disconnect the connectors ECM_L_J2 and E25A, and connect the T-adapter to female side of ECM_L_J2.		
		Continuity	Between ECM_L_J2 (female) (42) and each pin other than pin (42)	No continuity

**FAILURE CODE [CA3322]**

Action level	Failure code	Failure	HC Desorb Request 1 (Engine controller system)
L03	CA3322		
Detail of failure	The temperature detected by KDPF outlet temperature sensor differs from the expected value. (Signal voltage is within input range.)		
Action of controller	<ul style="list-style-type: none"> <li>• Uses KDOC outlet temperature for KDPF outlet temperature to run engine.(If failure is detected in KDOC outlet temperature sensor, too, controller takes it that KDPF outlet temperature is at default value (250 °C) and allows engine to run.)</li> <li>• Engine power deration.</li> <li>• Closes EGR valve.</li> <li>• Stops regeneration control.</li> <li>• Stops fuel dosing.</li> </ul>		
Phenomenon on machine	Engine output is reduced.		
Related information	<ul style="list-style-type: none"> <li>• Connectors of electrical parts around engine may be defective due to heat and vibration. See “RELATED INFORMATION ON TROUBLESHOOTING”, “CHECKS BEFORE TROUBLESHOOTING”, “Electrical equipment”, and check them according to the descriptions of wiring harness and connectors.</li> </ul> <p><b>⚠ KDPF and KDOC are heated to Min. 500 °C. Be careful not to get burn injury.</b></p> <ul style="list-style-type: none"> <li>• Temperature detected by KDPF outlet temperature sensor can be checked by monitoring. (Code: 47200)</li> <li>• If failure code [CA1925] or [CA1963] is displayed, fuel doser solenoid valve 1 may be defective. Perform troubleshooting for [CA1925] or [CA1963] first.</li> <li>• If failure code [CA3319] or [CA3321] is displayed, KDPF outlet temperature sensor may be defective. Perform troubleshooting for [CA3319] or [CA3321] first.</li> <li>• Temperature detected by KDPF outlet temperature sensor can be checked by monitoring. (Code: 47200)</li> <li>• To restart engine, wait until system operating lamp goes out after turning starting switch to OFF position, and then turn the starting switch to ON position.</li> </ul> <p><b>NOTICE</b></p> <ul style="list-style-type: none"> <li>• <b>This failure code requires “Loaded Diagnostics Operation To Confirm Failure Correction”. After investigating the cause of the problem and completing the repair, perform “Loaded Diagnostics Operation To Confirm Failure Correction” to ensure the failure code is cleared.</b></li> <li>• <b>This failure code can be cleared by performing “SERVICE MODE” and “METHOD FOR OPERATING TESTING MENU (ENGINE CONTROLLER ACTIVE FAULT CLEAR)” in TESTING AND ADJUSTING, “SET AND OPERATE MACHINE MONITOR”.</b></li> </ul>		

**FAILURE CODE [CB272]**

Action level	Failure code	Failure	PCV 1 Open Circuit Error_2 (Engine controller system)
L03	CB272		
Detail of failure	Open circuit is detected in supply pump PCV1_R circuit.		
Action of controller	None in particular		
Phenomenon on machine	<ul style="list-style-type: none"> <li>• Engine output is reduced.</li> <li>• Engine startability becomes poor.</li> </ul>		
Related information	<ul style="list-style-type: none"> <li>• Connectors of electrical parts around engine may be defective due to heat and vibration. See "RELATED INFORMATION ON TROUBLESHOOTING", "CHECKS BEFORE TROUBLESHOOTING", "Electrical equipment", and check them according to the descriptions of wiring harness and connectors.</li> <li>• While engine is running normally, Approx. 24 V of pulse voltage is supplied to PCV1_R(1). Because it is pulse voltage, it cannot be measured by using multimeter.</li> <li>• After completion of repair, check with following operation that the failure code is cleared. Procedure: Start the engine.</li> </ul>		

No.	Cause	Procedure, measuring location, criteria and remarks	
1	Defective supply pump PCV1_R	1. Turn the starting switch to OFF position.	
		2. Disconnect the connector PCV1_R, and connect the socket to male side.	
		Resistance	Between PCV1_R (male) (1) and (2) 2.3 to 5.3 Ω
		Between PCV1_R (male) (1) and ground	Min. 1 MΩ
2	Open circuit in wiring harness	1. Turn the starting switch to OFF position.	
		2. Disconnect the connector ECM_R_J1, and connect the T-adapter to female side.	
		Resistance	Between ECM_R_J1 (female) (23) and (24) (PCV1_R resistance) 2.3 to 5.3 Ω
3	Defective engine controller	If no failure is found by preceding checks, engine controller is defective. (Since this is an internal defect, troubleshooting cannot be performed.)	

**Circuit diagram related to PCV1**

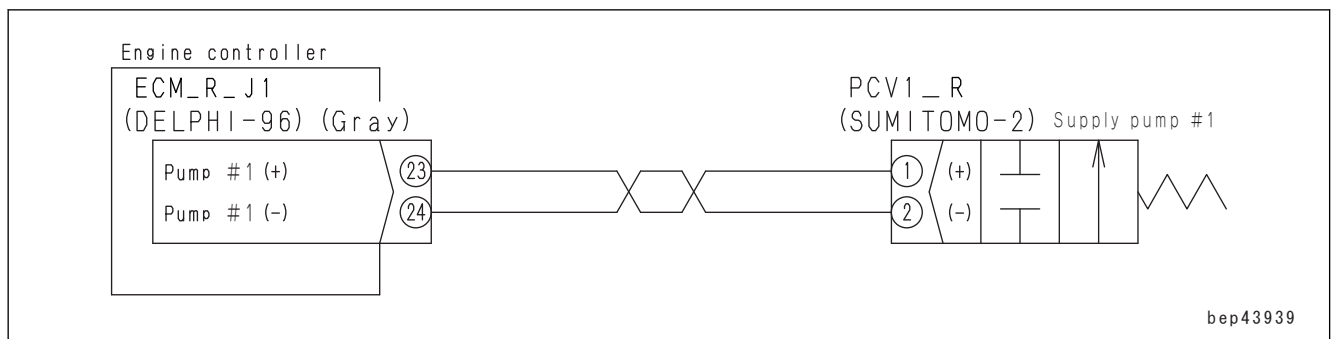

**FAILURE CODE [CB689]**

Action level	Failure code	Failure	Engine NE Speed Sensor Error_2 (Engine controller system)
L01	CB689		
Detail of failure	Error occurs in the signal from engine NE speed sensor.		
Action of controller	Operates by Bkup speed sensor (R) signal. Stops driving the right bank (when Bkup speed sensor (R) is also defective).		
Phenomenon on machine	Engine power deration (when Bkup speed sensor (R) is also defective).		
Related information	<ul style="list-style-type: none"> <li>Connectors of electrical parts around engine may be defective due to heat and vibration. See "RELATED INFORMATION ON TROUBLESHOOTING", "CHECKS BEFORE TROUBLESHOOTING", "Electrical equipment", and check them according to the descriptions of wiring harness and connectors.</li> <li>If failure code [CB238] or [CB239] is displayed, perform troubleshooting for that code first.</li> <li>Engine speed can be checked by monitoring. (Code: 01002)</li> <li>Speed sensor detects holes of flywheel and figures out the engine speed.</li> <li>After completion of repair, check with following operation that the failure code is cleared. Procedure: Start the engine.</li> </ul>		

No.	Cause	Procedure, measuring location, criteria and remarks		
1	Open circuit in wiring harness	1. Turn the starting switch to OFF position. 2. Disconnect the connectors ECM_L_J1, ECM_R_J1 and NE, and connect the T-adapter to each female side.		
		Resistance	Between ECM_R_J1 (female) (79) and NE (female) (1)	Max. 1 Ω
			Between ECM_R_J1 (female) (55) and NE (female) (2)	Max. 1 Ω
			Between ECM_R_J1 (female) (31) and NE (female) (3)	Max. 1 Ω
2	Ground fault in wiring harness	1. Turn the starting switch to OFF position. 2. Disconnect the connectors ECM_R_J1 and NE, and connect the T-adapter to either female side.		
		Resistance	Between ground and ECM_R_J1 (female) (31) or NE (female) (3)	Min. 1 MΩ
3	Hot short circuit in wiring harness	1. Turn the starting switch to OFF position. 2. Disconnect the connector NE, and connect the T-adapter to female side. 3. Turn the starting switch to ON position.		
		Voltage	Between ground and NE (female) (3)	Max. 1 V
4	Defective installation of flywheel	Perform checks since installation of the flywheel may be defective (looseness).		
5	Damaged engine NE speed sensor or defective installation	Perform checks since the engine NE speed sensor installation (looseness) may be defective.		

**FAILURE CODE [CB1844]**

Action level	Failure code	Failure	Crankcase Pressure Sensor Low Error_2 (Engine controller system)
L01	CB1844		
Detail of failure	Low voltage error is detected in signal circuit of crankcase pressure sensor.		
Action of controller	Sets the crankcase pressure to fixed value (0 kPa), and runs engine.		
Phenomenon on machine	None in particular		
Related information	<ul style="list-style-type: none"> <li>Connectors of electrical parts around engine may be defective due to heat and vibration. See "RELATED INFORMATION ON TROUBLESHOOTING", "CHECKS BEFORE TROUBLESHOOTING", "Electrical equipment", and check them according to the descriptions of wiring harness and connectors.</li> <li>If failure code [CB352] or [CB386] is also displayed, sensor power supply system may be defective. Perform troubleshooting for that code first.</li> <li>Signal voltage from crankcase pressure sensor can be checked by monitoring. (Code: 48401)</li> <li>Pressure detected by crankcase pressure sensor can be checked by monitoring. (Code: 48400)</li> <li>After completion of repair, check with following operation that the failure code is cleared. Procedure: Turn the starting switch to ON position.</li> </ul>		

No.	Cause	Procedure, measuring location, criteria and remarks		
1	Open circuit in wiring harness	1. Turn the starting switch to OFF position. 2. Disconnect the connectors ECM_R_J1 and PCCV_R, and connect the T-adapter to each female side.		
		Resistance	Between ECM_R_J1 (female) (78) and PCCV_R (female) (1)	Max. 1 Ω
			Between ECM_R_J1 (female) (54) and PCCV_R (female) (2)	Max. 1 Ω
			Between ECM_R_J1 (female) (63) and PCCV_R (female) (3)	Max. 1 Ω
2	Ground fault in wiring harness	1. Turn the starting switch to OFF position. 2. Disconnect the connectors ECM_R_J1 and PCCV_R, and connect the T-adapter to either female side.		
		Resistance	Between ground and ECM_R_J1 (female) (63) or PCCV_R (female) (3)	Min. 1 MΩ
3	Short circuit in wiring harness	1. Turn the starting switch to OFF position. 2. Disconnect the connectors ECM_R_J1 and PCCV_R, and connect the T-adapter to either female side.		
		Resistance	Between ECM_R_J1 (female) (63) and (54), or between PCCV_R (female) (2) and (3)	Min. 1 MΩ
4	Defective crankcase pressure sensor	1. Turn the starting switch to OFF position. 2. Insert the T-adapter into connector PCCV_R. 3. Turn the starting switch to ON position.		
		Voltage	Between PCCV_R (3) and (2)	0.3 to 4.7 V

A. Visual check							Go od	No go od
1	Fuel leakage to outside							
2	Clogged fuel tank breather							
B. Check with machine monitor (02 Abnormality Record, 01 Monitoring, 09 Cylinder Cutout Mode Operation)							Go od	No go od
3	Check of failure code							
4	Check of monitoring information							
	Code	Item to be displayed	Testing conditions	ISO unit	Standard value (reference value)	Measured value	Go od	No go od
	01002	Engine speed	Low idle	r/min	800 (±25)			
			High idle	r/min	1977 (±50)			
			Arm IN relief	r/min	1880 (±100)			
	31701	Throttle Position	Low idle	%	0			
			High idle	%	100			
	18600	Final inject fueling command (in weight)	Arm IN relief	mg/st	-		-	-
	36200	Rail Pressure Command	Arm IN relief	MPa	-			
	36400	Common Rail Pressure	Arm IN relief	MPa	-			
	36300	Injection Timing Command	Low idle	CB	-		-	-
			High idle	CB	-		-	-
			Arm IN relief	CB	-		-	-
	36500	Charge Pressure	Arm IN relief	kPa	-		-	-
04107	Coolant Temperature	Low idle	°C	-		-	-	
14200	Fuel Temperature	Low idle	°C	-		-	-	
5	Check of Cylinder Cutout Mode Operation (engine speed)							
	Function	Cutout cylinder	Testing conditions	ISO unit	Standard value (reference value)	Measured value	Go od	No go od
	Set cut-out to each cylinder.	No.1 cylinder	Low idle	r/min	-		-	-
		No.2 cylinder	Low idle	r/min	-		-	-
		No.3 cylinder	Low idle	r/min	-		-	-
		No.4 cylinder	Low idle	r/min	-		-	-
		No.5 cylinder	Low idle	r/min	-		-	-
No.6 cylinder		Low idle	r/min	-		-	-	

No.	Cause	Procedure, measuring location, criteria and remarks
1	Defective engine controller	If the failure code is not cleared after Cancel of Regeneration Disable from the machine monitor, the engine controller is defective. (Since this is an internal defect, troubleshooting cannot be performed.)

**FAILURE CODE [CB3314]**

Action level	Failure code	Failure	KDOC Inlet Temperature Sensor High Error_2 (Engine controller system)
L03	CB3314		
Detail of failure	Open circuit, hot short circuit, or sensor circuit error in KDOC inlet temperature sensor measuring section or probe (+) side		
Action of controller	<ul style="list-style-type: none"> <li>• Uses KDOC outlet temperature for KDOC inlet temperature to run the engine. (If failure is detected in KDOC outlet temperature sensor as well, the controller runs engine with the default value (250 °C).)</li> <li>• Engine power deration.</li> <li>• Closes EGR valve.</li> <li>• Stops regeneration control.</li> <li>• Stops fuel dosing.</li> </ul>		
Phenomenon on machine	<ul style="list-style-type: none"> <li>• Control malfunction of active regeneration</li> <li>• Soot accumulation is high.</li> <li>• Engine output is reduced.</li> </ul>		
Related information	<ul style="list-style-type: none"> <li>• Connectors of electrical parts around engine may be defective due to heat and vibration. See “RELATED INFORMATION ON TROUBLESHOOTING”, “CHECKS BEFORE TROUBLESHOOTING”, “Electrical equipment”, and check them according to the descriptions of wiring harness and connectors.</li> <li>• <b>⚠ KDPF and KDOC are heated to Min. 500 °C. Be careful not to get burn injury.</b></li> <li>• Engine power deration is canceled by turning the starting switch to OFF position after this failure code is cleared. (This deration is not canceled by simply failure code being cleared.)</li> <li>• After completion of repair, check with following operation that the failure code is cleared. Procedure: Turn the starting switch to ON position.</li> </ul>		

No.	Cause	Procedure, measuring location, criteria and remarks
1	Defective KDOC inlet temperature sensor	When KDPF is cooled down sufficiently or at idle (non-regeneration), if there are significant differences between KDOC inlet temperature and KDOC outlet temperature or KDPF outlet temperature, replace the sensor.  <b>REMARK</b> As to procedure for accessing KDOC inlet temperature sensor, KDOC outlet temperature sensor, and KDPF outlet temperature sensor, see DISASSEMBLY AND ASSEMBLY, “REMOVE AND INSTALL KDPF ASSEMBLY” and “DISASSEMBLE AND ASSEMBLE OF KDPF ASSEMBLY”.
2	Defective engine controller	If no failure is found by preceding checks, engine controller is defective. (Since this is an internal defect, troubleshooting cannot be performed.)

### Circuit diagram related to flash light relay

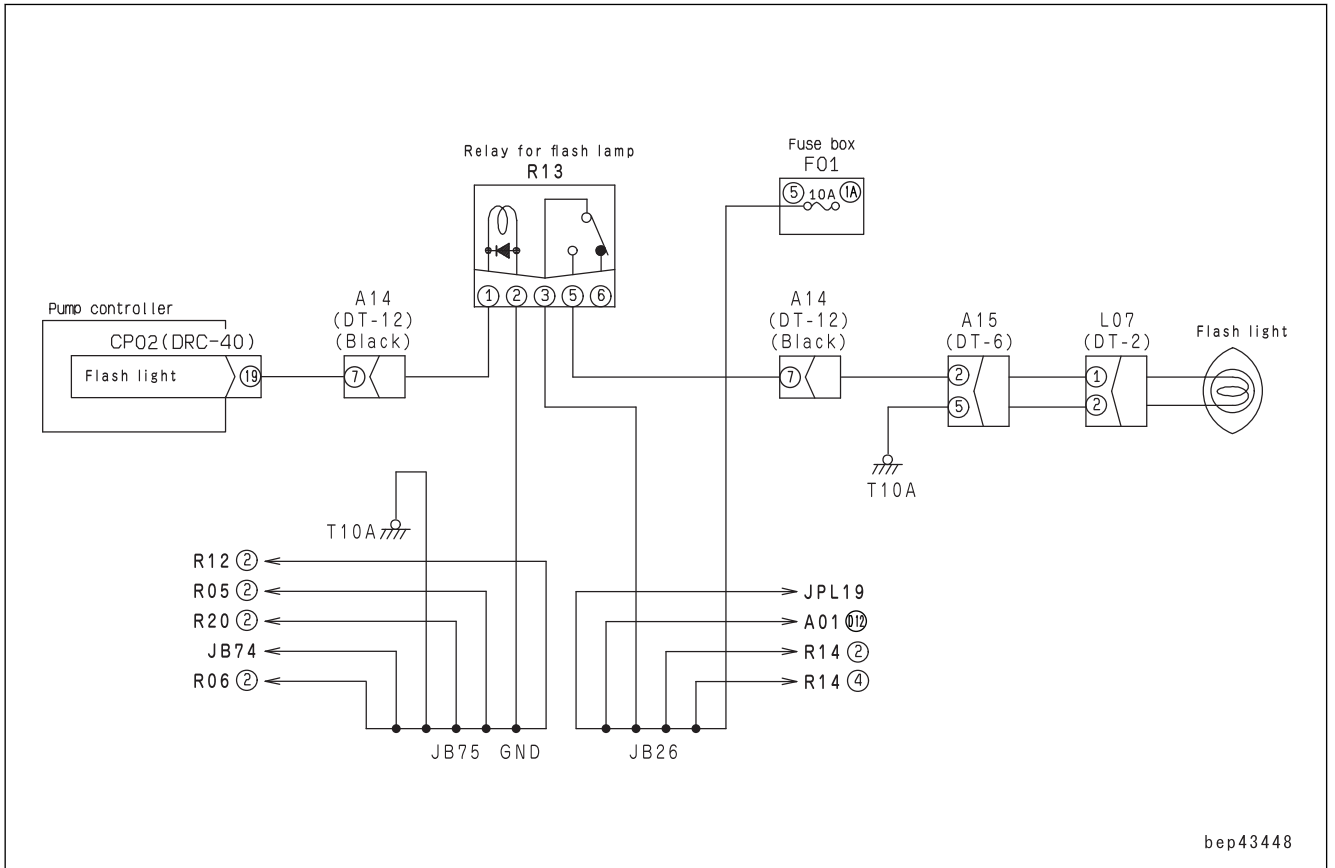

No.	Cause	Procedure, measuring location, criteria and remarks		
3	Ground fault in wiring harness	1. Turn the starting switch to OFF position. 2. While this failure code is displayed, it cannot be checked if the system operating lamp is turned off. Turn the battery disconnect switch to OFF position 3 minutes after turning the starting switch to OFF position. 3. Remove the fuse No.19 in the fuse box F01. 4. Disconnect the connector L19B, and connect the T-adapter to female side.		
		Resistance	Between ground and either F01-19 or L19B (female) (1)	Min. 1 MΩ
4	Defective pump controller	If no failure is found by preceding checks, pump controller is defective. (Since this is an internal defect, troubleshooting cannot be performed.)		

**FAILURE CODE [DB2RKR]**

Action level	Failure code	Failure	CAN 1 Defective Communication (Engine controller) (Machine monitor system)
L04	DB2RKR		
Detail of failure	Machine monitor does not recognize engine controller through CAN communication 1 line (KOM-NET/r).		
Action of controller	<ul style="list-style-type: none"> <li>Retains current working mode.</li> <li>Retains current selection of auto-deceleration.</li> <li>Retains information when the failure occurred.</li> </ul>		
Phenomenon on machine	<ul style="list-style-type: none"> <li>Information to be obtained from engine controller is not displayed and special functions that need information do not work. Or update of received data is stopped.</li> <li>Engine is uncontrollable.</li> <li>Engine speed and coolant temperature are undetectable.</li> <li>A gauge pointer for engine coolant temperature and hydraulic oil temperature disappears on machine monitor screen.</li> </ul>		
Related information	<ul style="list-style-type: none"> <li>Start of CAN communication is recognized by each controller when ACC signal of starting switch is received.</li> <li>If failure code [CA441] is also displayed, perform troubleshooting for that code first.</li> <li>If failure code [DB2QKR] is also displayed, engine controller system in cause 1 is probably defective.</li> <li>2 different failure codes, [DA2RKR] and [DBVRKR] are used for defective CAN communication by CAN 1 when it is detected by machine monitor. When these 2 failure codes are displayed, ground fault, short circuit or hot short circuit in wiring harness (CAN communication circuit) can be suspected.</li> <li>Terminating resistor of CAN 1 on cab side is provided in machine monitor, and that on engine side is connector "KOM/r_RES".</li> <li>Since each controller and machine monitor are connected directly to battery, they are supplied with power even after starting switch is turned to OFF position.</li> <li>Since signal of active CAN communication line is pulse voltage, it cannot be measured by using multimeter.</li> <li>After completion of repair, check with following operation that the failure code is cleared. Procedure: Turn the starting switch to ON position.</li> </ul>		

Circuit diagram related to system operating lamp

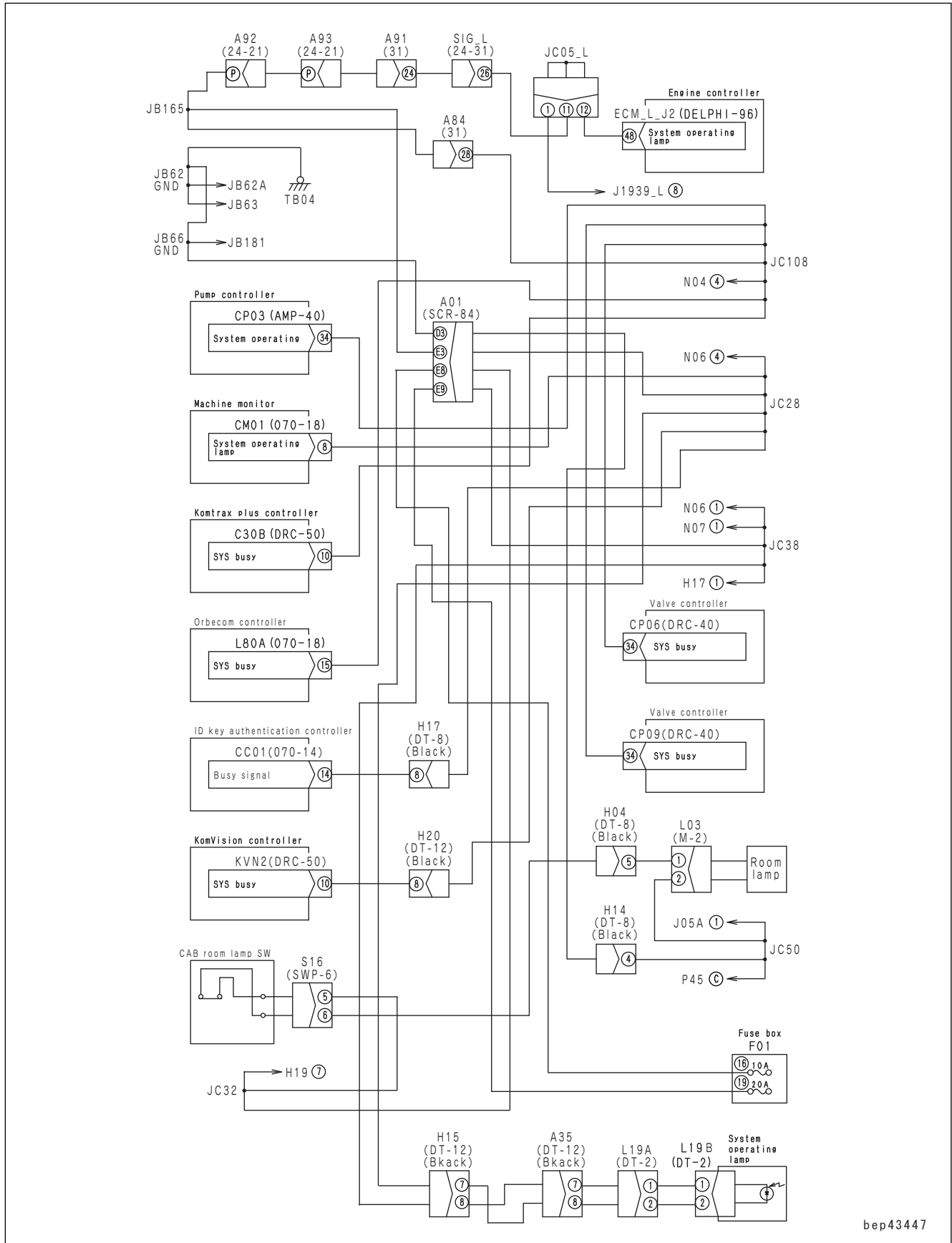

bep43447

## FAILURE CODE [DBXQKR]

Action level	Failure code	Failure	CAN 2 defective communication (Valve 2 controller) (Machine monitor system)
L03	DBXQKR		
Detail of failure	Machine monitor cannot recognize valve 2 controller through CAN communication 2 line (KOMNET/c).		
Action of controller	Retains information when the failure occurred.		
Phenomenon on machine	Information and special functions obtained from valve 2 controller do not operate or are not displayed. Receive data are not updated in other cases (Such as failure codes and monitoring codes sent from valve 2 controller).		
Related information	<ul style="list-style-type: none"> <li>After completion of repair, check with following operation that the failure code is cleared. Procedure: Turn the starting switch to ON position.</li> <li>Start of CAN communication is recognized by each controller when ACC signal of starting switch is received.</li> <li>8 different failure codes, [DA2QKR], [DB2QKR], [DBWQKR], [DBXQKR], [DAFQKR], [DBPQKR], [DBVQKR], and [D8AQKR] are used for defective CAN communication by CAN 2 when it is detected by machine monitor. When all of these 8 failure codes are displayed, ground fault, short circuit or hot short circuit in wiring harness (CAN communication line) can be suspected.</li> <li>This can be activated even when power supply to valve 2 controller is turned off.</li> </ul> <p><b>REMARK</b></p> <ul style="list-style-type: none"> <li>Since each controller and machine monitor are connected directly to battery, they are supplied with power even after starting switch is turned to OFF position.</li> <li>Since signal of active CAN communication line is pulse voltage, it cannot be measured by using multimeter.</li> </ul>		

No.	Cause	Procedure, measuring location, criteria and remarks		
1	Defective valve 2 controller power supply circuit	<ol style="list-style-type: none"> <li>Turn the starting switch to OFF position.</li> <li>Check that the system operating lamp is turned off, and then turn the battery disconnect switch to OFF position.</li> <li>Disconnect the connector CP06, and connect the T-adaptor to female side.</li> <li>Turn the battery disconnect switch to ON position.</li> <li>Turn the starting switch to ON position.</li> </ol>		
		Voltage	Between CP06 (female) (1) and ground	20 to 30 V
2	Open circuit in wiring harness	<ol style="list-style-type: none"> <li>Turn the starting switch to OFF position.</li> <li>Check that the system operating lamp is turned off, and then turn the battery disconnect switch to OFF position.</li> <li>Disconnect the connector CP06, and connect T-adaptor to female side. Disconnect the connector B01, and connect T-adaptor to male side.</li> </ol>		
		Resistance	Between CP06 (female) (1) and B01 (male) (4)	Max. 1 Ω
			Between CP06 (female) (21) and ground	Max. 1 Ω

No.	Cause	Procedure, measuring location, criteria and remarks	
4	Short circuit in wiring harness	1. Turn the starting switch to OFF position. 2. Disconnect the connectors CP01 and P22, and connect the T-adapter to female side.	
		Resistance	Between CP01 (9) and (21) or between P22 (female) (1) and (2) Min. 1 MΩ
5	Defective pump controller	If no failure is found by above checks, pump controller is defective. (Since this is an internal defect, troubleshooting cannot be performed).	

**Circuit diagram related to hydraulic oil temperature sensor**

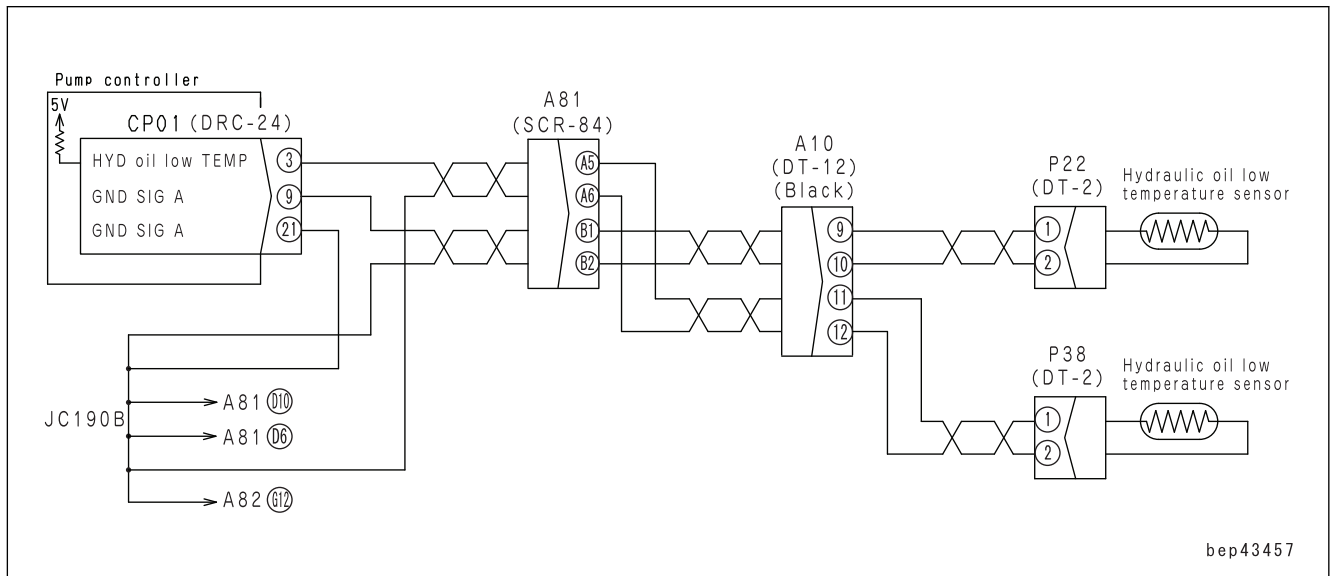

**FAILURE CODE [DHS3MA]**

Action level	Failure code	Failure	Arm IN PPC Pressure Sensor Malfunction (Pump controller system)
L01	DHS3MA		
Detail of failure	Signal voltage of arm IN PPC pressure sensor circuit is Max. 0.3 V or Min. 4.5 V.		
Action of controller	Controls arm IN PPC pressure sensor as 0 MPa. If cause of failure disappears, machine becomes normal by itself.		
Phenomenon on machine	Auto-deceleration function cannot be reset. Operability of arm IN is poor.		
Related information	<p><b>REMARK</b></p> <p>If 5V circuit (3) and GND circuit (1) of pressure sensor are connected inversely, pressure sensor will break. Accordingly, take extreme care when checking.</p> <ul style="list-style-type: none"> <li>As T-adapter for pump controller connector is “socket-type box”, operating voltage cannot be measured at pump controller connector.</li> <li>Arm IN PPC pressure can be checked with monitoring function. (Code: 07200 Arm IN PPC pressure))</li> <li>After completion of repair, check with following operation that the failure code is cleared. Procedure: Turn the starting switch to ON position or start the engine.</li> </ul>		

No.	Cause	Procedure, measuring location, criteria and remarks						
1	Defective 5 V sensor 1 power supply system	If failure code [DA26KP] is also displayed, perform troubleshooting for that code first.						
		<ol style="list-style-type: none"> <li>Turn the starting switch to OFF position.</li> <li>Disconnect the connector P06, and connect the T-adapter to female side.</li> <li>Turn the starting switch to ON position.</li> </ol> <p>If power supply voltage is abnormal, go to check on cause 3 and after.</p> <table border="1"> <tr> <td>Voltage</td> <td>Between P06 (female) (3) and (1)</td> <td>Power supply</td> <td>4.5 to 5.5 V</td> </tr> </table>			Voltage	Between P06 (female) (3) and (1)	Power supply	4.5 to 5.5 V
Voltage	Between P06 (female) (3) and (1)	Power supply	4.5 to 5.5 V					
2	Defective arm IN PPC pressure sensor (Internal defect)	<ol style="list-style-type: none"> <li>Turn the starting switch to OFF position.</li> <li>Insert the T-adapter into connector P06.</li> <li>Turn the starting switch to ON position.</li> </ol> <table border="1"> <tr> <td>Voltage</td> <td>Between P06 (2) and (1)</td> <td>Sensor output</td> <td>0.5 to 4.5 V</td> </tr> </table> <p><b>REMARK</b></p> <p>If power supply voltage is normal and sensor output voltage is abnormal, it is difficult to determine the failure between ground fault and hot short circuit in wiring harness. Check as follows.</p> <ol style="list-style-type: none"> <li>Turn the starting switch to OFF position.</li> <li>Exchange the connector P06 with connector of other PPC pressure sensor.</li> <li>Turn the starting switch to ON position, and display “Electrical System Abnormality Record” screen of machine monitor.</li> <li>If E mark is not displayed again for this failure code, arm IN PPC pressure sensor is defective.</li> </ol> <p><b>REMARK</b></p> <p>After troubleshooting, restore the connector.</p>			Voltage	Between P06 (2) and (1)	Sensor output	0.5 to 4.5 V
		Voltage	Between P06 (2) and (1)	Sensor output	0.5 to 4.5 V			

**FAILURE CODE [DKR1MA]**

Action level	Failure code	Failure	Rear Pump Swash Plate Sensor Malfunction (Pump controller system)
L01	DKR1MA		
Detail of failure	Signal voltage of front pump swash plate sensor circuit is Max. 0.5 V or Min. 4.5 V.		
Action of controller	If cause of failure disappears, machine becomes normal by itself.		
Phenomenon on machine	Function to control the engine and lower the low load matching speed does not work.		
Related information	<p><b>REMARK</b></p> <p>If 5 V circuit (A) and GND circuit (B) of swash plate sensor are connected inversely, pressure sensor will break. Accordingly, take extreme care when checking.</p> <ul style="list-style-type: none"> <li>As T-adapter for pump controller connector is "socket-type box", operating voltage cannot be measured at pump controller connector.</li> <li>Voltage from front pump swash plate sensor can be checked with monitoring function. (Code: 01138 Front pump swash plate sensor voltage)</li> <li>After completion of repair, check with following operation that the failure code is cleared. Procedure: Start the engine</li> </ul>		

No.	Cause	Procedure, measuring location, criteria and remarks			
1	Defective 5 V sensor 1 power supply system	<ol style="list-style-type: none"> <li>Turn the starting switch to OFF position.</li> <li>Disconnect the connector P27B, and connect the T-adapter to female side.</li> <li>Turn the starting switch to ON position.</li> </ol>			
		Voltage	Between P27B (female) (A) and (B)	Power supply	4.5 to 5.5 V

**FAILURE CODE [DKVGMA]**

Action level	Failure code	Failure	Arm OUT PPC Pressure Sensor 2 Malfunction
L03	DKVGMA		
Detail of failure	Arm OUT PPC pressure sensor voltage is Max. 0.3 V or Min. 4.5 V.		
Action of controller	Stops outputting arm OUT EPC.		
Phenomenon on machine	Arm OUT speed becomes slow.		
Related information	After completion of repair, check with following operation that the failure code is cleared. Procedure: Turn the starting switch to ON position.		

No.	Cause	Procedure, measuring location, criteria and remarks		
1	Defective 5 V sensor 1 power supply system	If failure code [DA26KP] is also displayed, perform troubleshooting for that code first.		
		<ol style="list-style-type: none"> <li>Turn the starting switch to OFF position.</li> <li>Disconnect the connector P05A, and connect the T-adaptor to female side.</li> <li>Turn the starting switch to ON position.</li> </ol>		
		Voltage	Between P05A (female) (3) and (1)	Power supply
2	Defective swing RIGHT PPC pressure sensor	<ol style="list-style-type: none"> <li>Turn the starting switch to OFF position.</li> <li>Insert the T-adaptor into connector P05A.</li> <li>Turn the starting switch to ON position.</li> </ol>		
		Voltage	Between P05A (2) and (1)	
3	Open circuit in wiring harness	<ol style="list-style-type: none"> <li>Turn the starting switch to OFF position.</li> <li>Disconnect the connectors CP07 and P05A, and connect the T-adaptor to each female side.</li> </ol>		
		Resistance	Between CP07 (female) (21) and P05A (female) (1)	Max. 1 Ω
			Between CP07 (female) (2) and P05A (female) (2)	Max. 1 Ω
			Between CP07 (female) (22) and P05A (female) (3)	Max. 1 Ω
4	Ground fault in wiring harness	<ol style="list-style-type: none"> <li>Turn the starting switch to OFF position.</li> <li>Disconnect the connectors CP07 and P05A, and connect the T-adaptor to either female side.</li> </ol>		
		Resistance	Between CP07 (female) (2) and ground, or P05A (female) (2) and ground	Min. 1 MΩ
5	Short circuit in wiring harness	<ol style="list-style-type: none"> <li>Turn the starting switch to OFF position.</li> <li>Disconnect the connectors CP07 and P05A, and connect the T-adaptor to female side of CP07.</li> </ol>		
		Resistance	Between CP07 (female) (2) and each pin other than (2)	No continuity

Circuit diagram related to rear camera

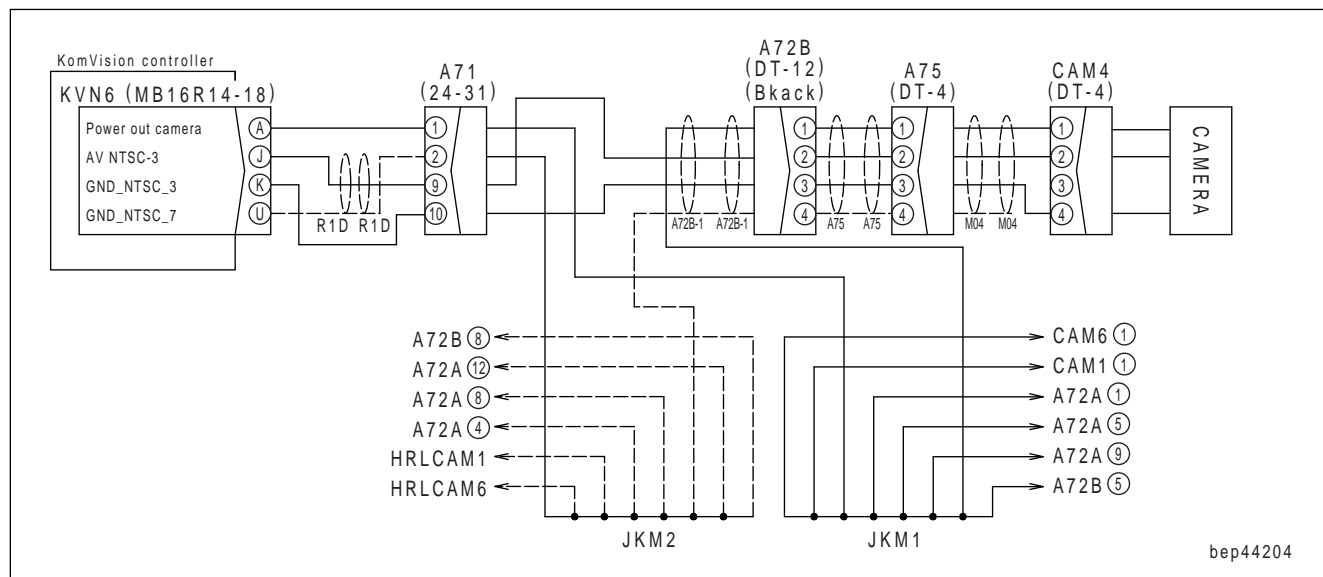

CLICK HERE TO **DOWNLOAD** THE COMPLETE MANUAL

- Thank you very much for reading the preview of the manual.
- You can download the complete manual from: [www.heydownloads.com](http://www.heydownloads.com) by clicking the link below



- Please note: If there is no response to CLICKING the link, please download this PDF first and then click on it.

CLICK HERE TO **DOWNLOAD** THE COMPLETE MANUAL

Circuit diagram related to 2-stage relief solenoid

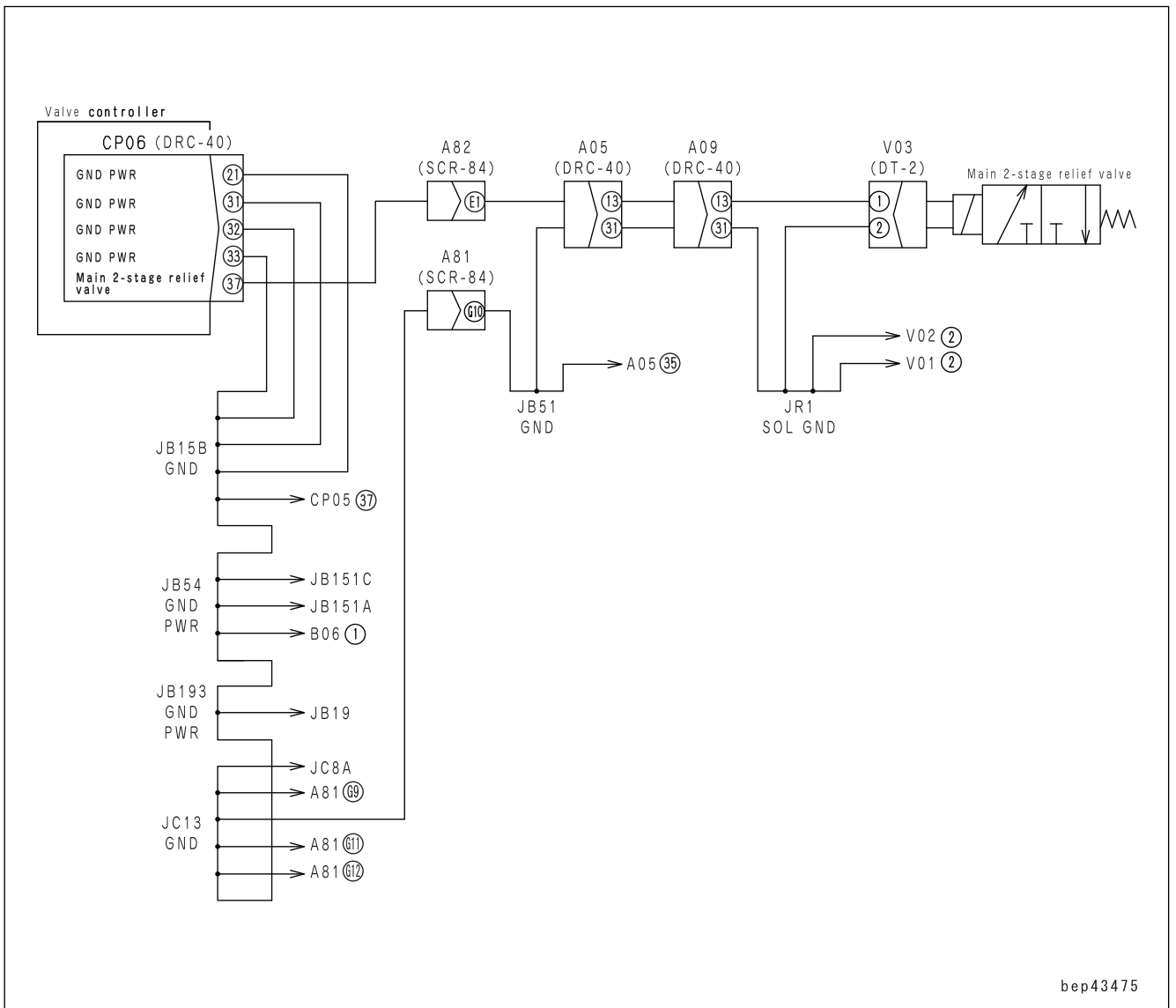

Circuit diagram related to main pump EPC solenoid

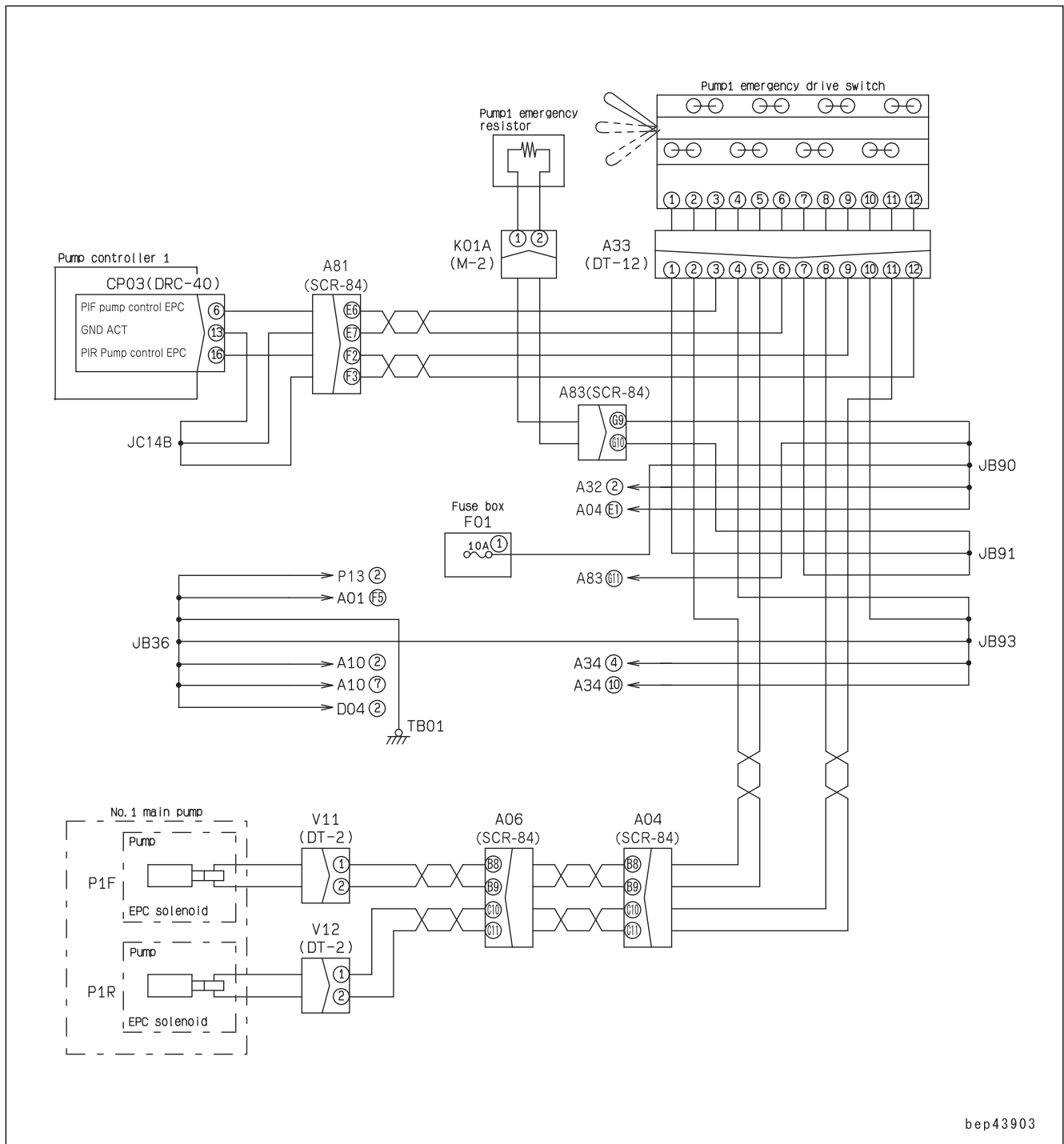

bep43903

## FAILURE CODE [DY2CKA]

Action level	Failure code	Failure	Window Washer Motor Open Circuit (Pump controller system)
-	DY2CKA		
Detail of failure	When controller drives window washer (GND is connected), output pressure of controller is higher than specified value, and open circuit is detected		
Action of controller	Stops output to washer motor. Even if cause of failure disappears, machine does not become normal until starting switch is turned to OFF position.		
Phenomenon on machine	Window washer does not operate.		
Related information	After completion of repair, check with following operation that the failure code is cleared. Procedure: Turn the starting switch to ON position + Turn on the washer switch.		

No.	Cause	Procedure, measuring location, criteria and remarks		
1	Defective fuse	1. Turn the starting switch to OFF position. 2. Check that the system operating lamp is turned off, and then turn the battery disconnect switch to OFF position. 3. Remove the fuse No.10 in the fuse box F01, and visually check it for burning out. 4. When it is not burnt out, check if it is blown out by continuity test.		
		<ul style="list-style-type: none"> <li>• When it is burnt out, check the wiring harness for ground fault.</li> <li>• When it is not burnt out but it has no continuity, replace the fuse.</li> </ul>		
2	Defective washer motor	1. Turn the starting switch to OFF position. 2. Disconnect the connectors M06A and M06B, and connect the T-adaptor to each male side.		
		Resistance	Between M06A (male) (1) and (2)	5 to 20 Ω
			Between ground and M06A (male) (1) or (2)	Min. 1 MΩ
			Between M06B (male) (1) and (2)	5 to 20 Ω
			Between ground and M06B (male) (1) or (2)	Min. 1 MΩ
3	Defective diode	1. Turn the starting switch to OFF position. 2. Disconnect the connector DW3, and connect the T-adaptor to male side.  <b>REMARK</b> Measure it with diode range.		
		Continuity	Between DW3 (male) (2) (+) and (1) (-)	Continuity
			Between DW3 (male) (1) (+) and (2) (-)	No continuity
4	Open circuit in wiring harness	1. Turn the starting switch to OFF position. 2. Disconnect the connector CP03 and relay RW5, and connect the T-adaptor to female side.		
		Resistance	Between CP02 (female) (84) and R48 (female) (1)	Max. 1 Ω
			Between RW5 (female) (2) and ground	Max. 1 Ω
5	Defective pump controller	If no failure is found by above checks, pump controller is defective. (Since this is an internal defect, troubleshooting cannot be performed).		

No.	Cause	Procedure, measuring location, criteria and remarks	
6	Hot short circuit in wiring harness	1. Turn the starting switch to OFF position. 2. Disconnect the connectors P21A and CM01, and connect the T-adapter to the female side. 3. Turn the starting switch to ON position.	
		<table border="1"> <tr> <td>Voltage</td> <td>Between CM01 (female) (15) and P21A (female) (1)</td> <td>Max. 1 V</td> </tr> </table>	Voltage
Voltage	Between CM01 (female) (15) and P21A (female) (1)	Max. 1 V	
7	Defective machine monitor	If no failure is found by preceding checks, the machine monitor is defective. (Since this is an internal defect, troubleshooting cannot be performed.)	

**Circuit diagram related to the fuel level sensor**

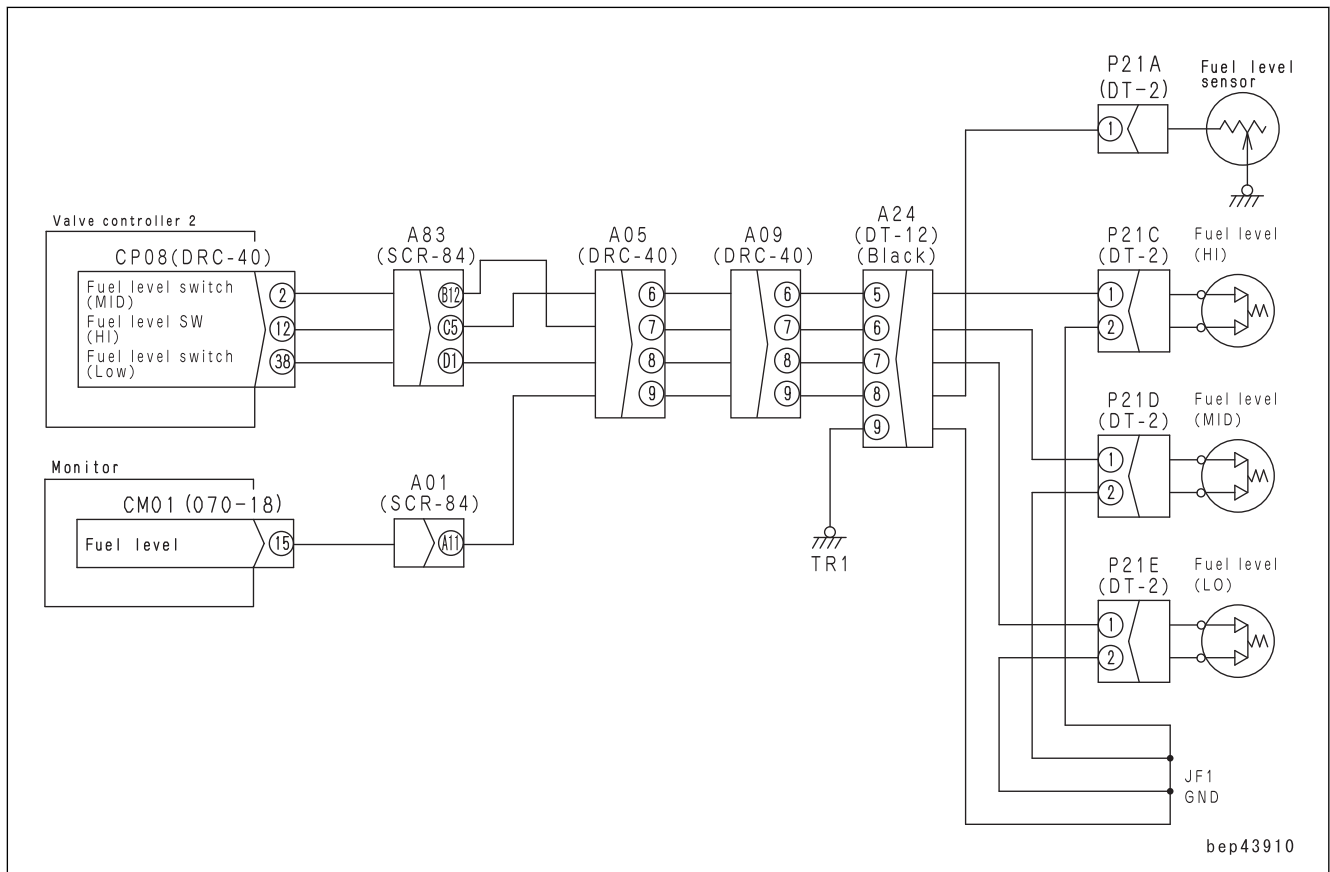

No.	Cause	Procedure, measuring location, criteria and remarks		
3	Ground fault in wiring harness	1. Turn the starting switch to OFF position. 2. Disconnect the connectors R08, R11, L01B, L01D, L01C and L01A, and connect the T-adapter to any female side.		
		Resistance	Between ground and L01B (female) (1) or R08 (female) (3)	Min. 1 MΩ
			Between ground and L01D (female) (1) or R08 (female) (1)	Min. 1 MΩ
			Between ground and L01C (female) (1) or R08 (female) (1)	Min. 1 MΩ
			Between ground and L01A (female) (1) or R08 (female) (3)	Min. 1 MΩ
			Between ground and L04B (female) (1) or R11 (female) (1) (working lamp)	Min. 1 MΩ
			Between ground and L04D (female) (1) or R08 (female) (3) (working lamp)	Min. 1 MΩ
			Between ground and L04C (female) (1) or R08 (female) (3) (working lamp)	Min. 1 MΩ
			Between ground and L04A (female) (1) or R08 (female) (1) (working lamp)	Min. 1 MΩ

Circuit diagram related to the air conditioner

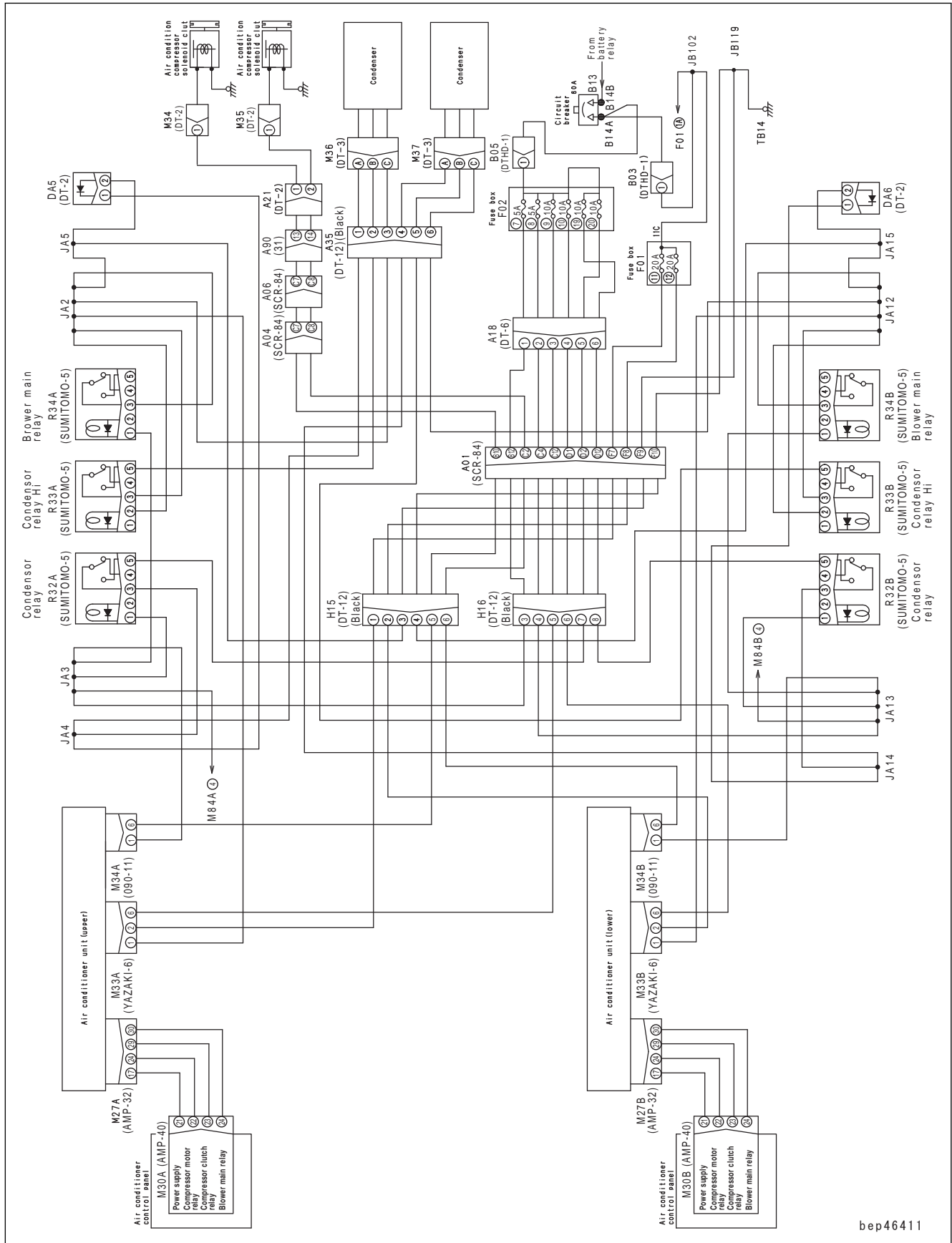

bep46411

## H-32 SWING ACCELERATION PERFORMANCE IS POOR OR SWING SPEED IS SLOW IN ONLY ONE DIRECTION

Failure	Swing acceleration performance is poor or swing speed is slow in only one direction.
Related information	<ul style="list-style-type: none"> <li>Check that the work equipment and travel mode are in the normal condition (if an abnormality is detected, perform the troubleshooting for related failure).</li> <li>Set the working mode to P+, turn the swing lock switch to OFF position, and then perform the troubleshooting for all the failures.</li> </ul>

No.	Cause	Procedure, measuring location, criteria and remarks	
1	Defective L.H. PPC valve (swing circuit)	Be ready with the engine stopped, and then perform troubleshooting with the engine at high idle.	
		PPC valve output pressure	L.H. control lever: Swing Left, Swing Right, full stroke Min. 2.74 MPa {Min. 28 kgf/cm <sup>2</sup> }
2	Defective swing control valve (spool)	The swing control valve spool may be defective. Check it directly.	
3	Defective swing control valve (suction valve)	The suction valve of the swing control valve may be defective. Check it directly. (Replacement between both sides is allowable, and you can check whether failure symptom changes for judgment.)	
4	Defective swing motor (suction valve)	The suction valve of the swing motor may be defective. Check it directly. (Replacement between both sides is allowable, and you can check whether failure symptom changes for judgment.)	
5	Defective swing motor (check valve)	The check valve of the swing motor may be defective. Check it directly. (Replacement between both sides is allowable, and you can check whether failure symptom changes for judgment.)	

**S-21 ACTIVE REGENERATION IS EXECUTED FREQUENTLY**

Failure	Active regeneration is executed frequently.
Related information	If any failure code is displayed, perform troubleshooting for that code first.

No.	Cause	Point to check, remarks	Remedy
1	Engine has been operated at a low or medium speed for prolonged time.	Unless heavy-duty operation is performed, soot is accumulated because the exhaust gas temperature does not rise.	Perform active regeneration for service and carry out complete combustion of soot to remove it completely.
2	Incorrect exhaust gas color	Remove the plug of hole for measuring the exhaust gas color before KDPF, and check the exhaust gas color. (Reference: For details, see TESTING AND ADJUSTING, "TEST EXHAUST GAS COLOR".)	Perform the troubleshooting for "KDPF GETS CLOGGED IN A SHORT TIME".
3	Blocked KDOC when exhaust gas color is defective	If frequency of regeneration is not improved after a corrective action for cause 2, KDOC is in a state of face plugging.	KDOC cleaning
4	Use of unspecified oil	Unspecified oil is used.	Use recommended oil described in Operation and Maintenance Manual.
5	Blocked KCSF by the use of unspecified oil	If frequency of regeneration is not improved after a corrective action for cause 4, KCSF is blocked.	KCSF cleaning and replacement
6	Coolant leakage to exhaust system	Check for lowering of coolant level.	Perform troubleshooting for "WATER MIXES INTO ENGINE OIL (MILKY)" in S mode.
7	Blocked KCSF caused by coolant leakage to exhaust system	Check for clogging at KCSF inlet.	KCSF cleaning and replacement
8	Use of unspecified fuel	Unspecified fuel is used.	Use recommended fuel described in Operation and Maintenance Manual.
9	Deteriorated KDOC by the use of unspecified fuel	Deteriorated KDOC due to high sulfur content (If the check result does not correspond to cause 1 to 9 and time of regeneration is not improved, KDOC is deteriorated.)	KDOC replacement
10	Ash accumulation to KDPF is actually large.	If the check result does not correspond to cause 1 to 9 and frequency of regeneration is not improved, ash accumulation to KDPF is actually large.	Perform TESTING AND ADJUSTING, "SET MACHINE MONITOR", "SERVICE MODE" and "TESTING MENU (ASH IN SOOT ACCUMULATION CORRECTION)".
11	Blocked KDOC	If the check result does not correspond to cause 1 to 10 and frequency of regeneration is not improved, KDOC is in a state of face plugging.	KDOC cleaning
12	Damaged KDOC	Check KDOC for damage.	KDOC replacement

SKETCHES OF SPECIAL TOOLS

Note: Komatsu does not take any responsibility for special tools manufactured according to these sketches.

Plate

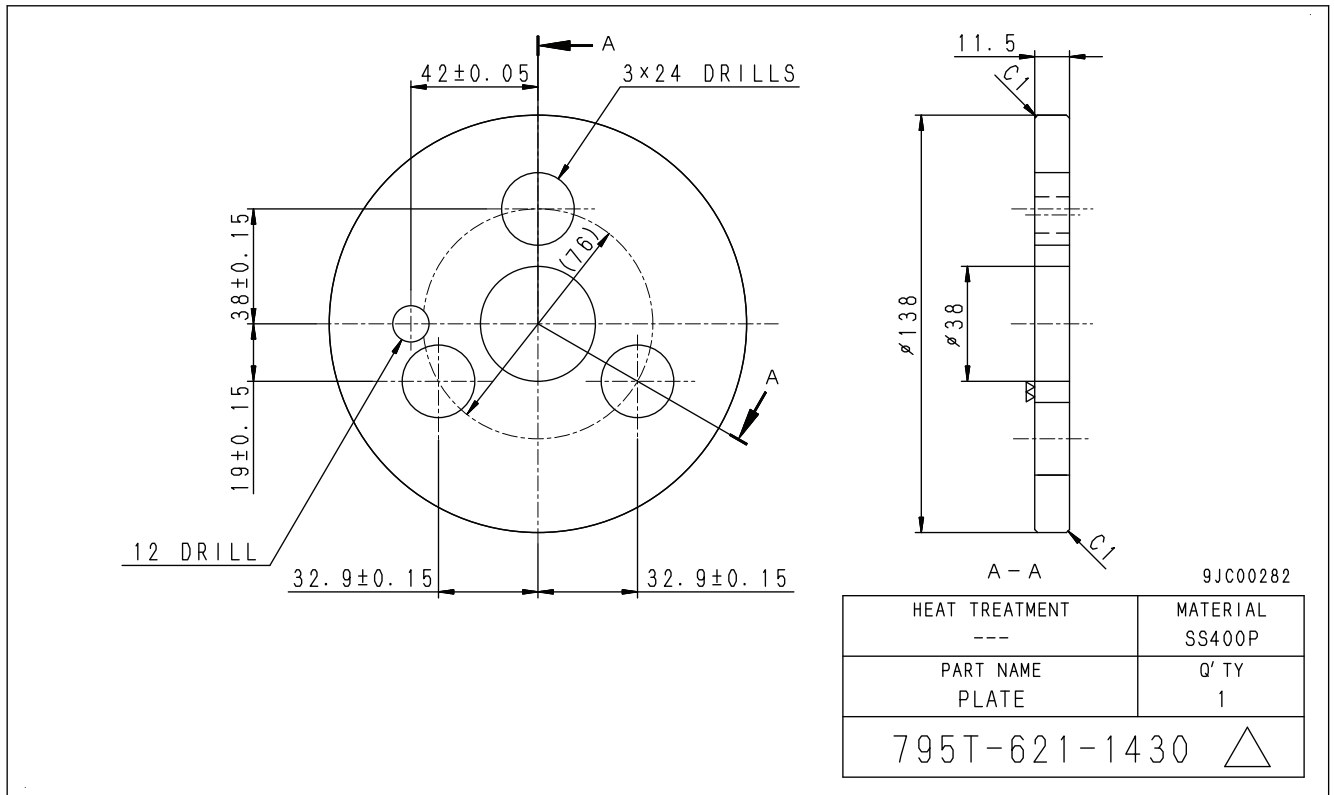

Push tool

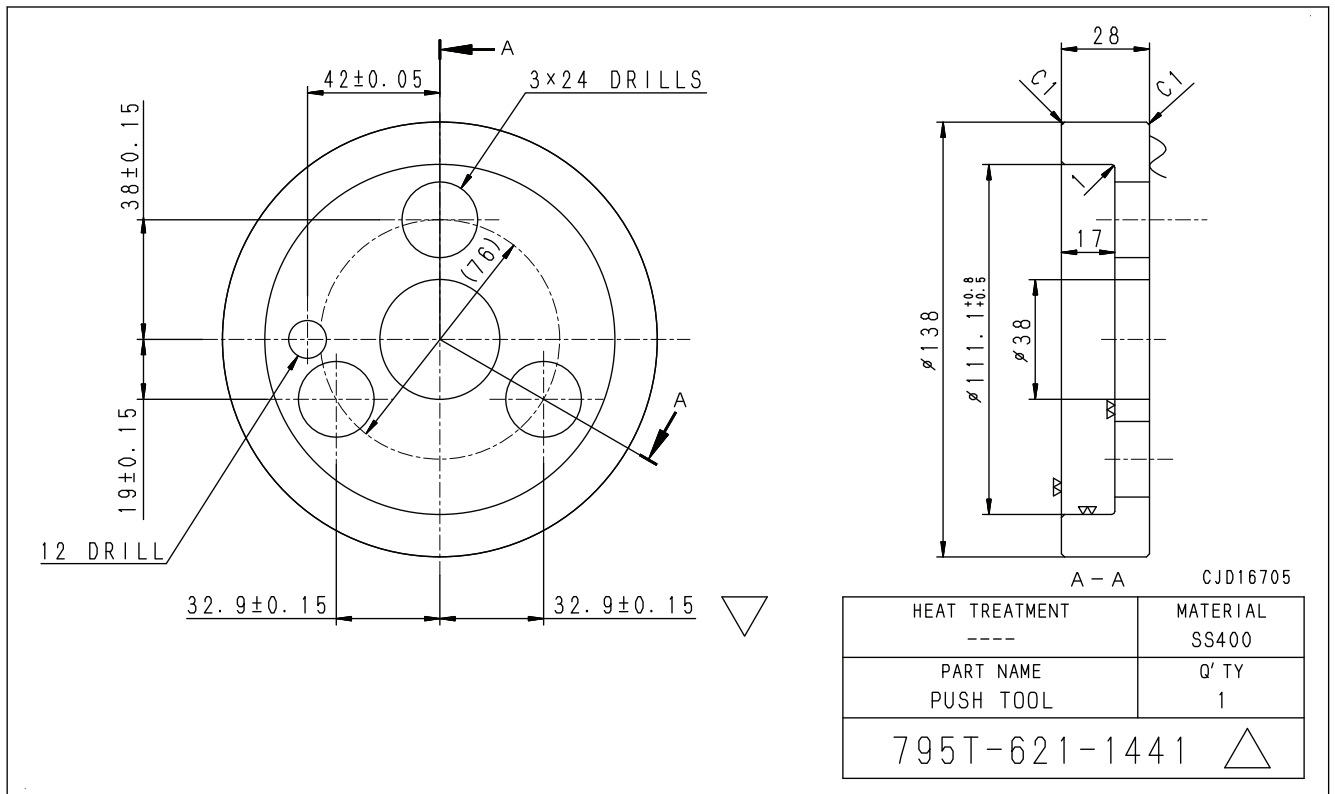

REMOVE AND INSTALL SUPPLY PUMP ASSEMBLY (LEFT BANK)

5. Remove bolts (6) (2 pieces).

Tool: Impact wrench, socket

Bolt (6): Width across flats 19 mm, M12

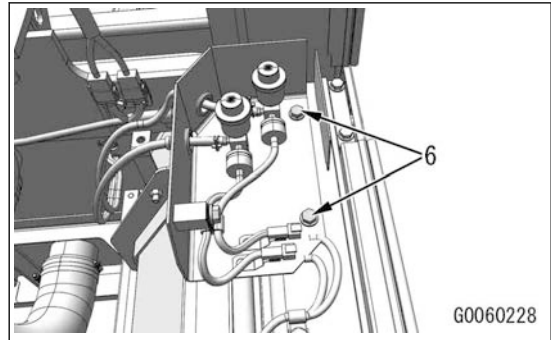

6. Remove clamps (7) (4 pieces), and disconnect hoses (8) (2 pieces).

Tool: Ratchet handle, socket

Clamp (7): Width across flats 11 mm

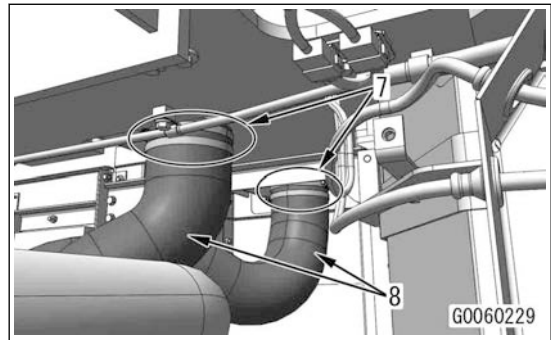

7. Disconnect connector A67 (9).

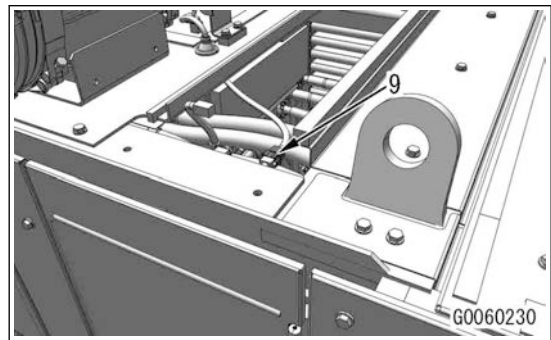

8. Remove bolts (10) (6 pieces), sling air cleaner assembly (11), and remove it.

Tool: Impact wrench, socket, wire sling

Bolt (10): Width across flats 19 mm, M12

 Air cleaner assembly (11):  
135 kg

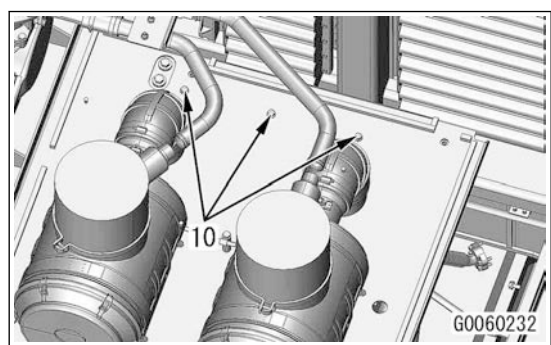
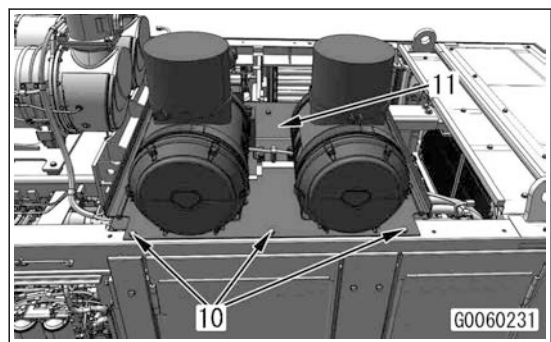

**KDPF assembly**

9. Remove KDPF assembly. For details, see "REMOVE AND INSTALL KDPF ASSEMBLY".

9. Adjust valve clearance for all the cylinders according to the following procedure.

- 1) Rotate crankshaft to positive rotation, set R.H. No.1 cylinder to compression top dead center according to movement of R.H. No.6 cylinder air intake valve, and then align stamp line (120) "R1.6TOP" of vibration damper (119) with pointer (121).

**REMARK**

- Perform cranking of engine with barring device (122) installed at front right of flywheel housing.
- When R.H. No.1 cylinder is around compression top dead center and air intake valve of R.H. No.6 cylinder moves, R.H. No.6 cylinder is at compression top dead center. R.H. No.1 cylinder comes at compression top dead center by rotating crankshaft to positive rotation by 1 turn. Check that air intake valve and exhaust valve can be moved by your hands as much as valve clearance when they are at compression top dead center.
- The figure shows number of cylinder and firing order. (Number in circle shows firing order.)

- 2) Loosen lock nut (103) of adjustment screw (104) of R.H. No.1 cylinder, insert feeler gauge for specified clearance between crosshead (123) and rocker arm (124), adjust it with adjustment screw (104) until you feel resistance.

Standard value of valve clearance  
 Air intake valve  $0.35 \pm 0.02$  mm  
 Exhaust valve  $0.57 \pm 0.02$  mm

- 3) Tighten lock nut (103) at this position, and fix adjustment screw (104).

**REMARK**

Check valve clearance again after tightening lock nut (103).

Tool: Torque wrench, box-end combination wrench, feeler gauge, flat-head screwdriver

Lock nut (103): Width across flats 17 mm

 Lock nut (103):  
 $58.7 \pm 5.9$  Nm { $6.0 \pm 0.6$  kgfm}

- 4) Perform cranking according to the firing order of engine, and adjust valve clearance of each cylinder while aligning each stamp line on vibration damper (119) with pointer (121).

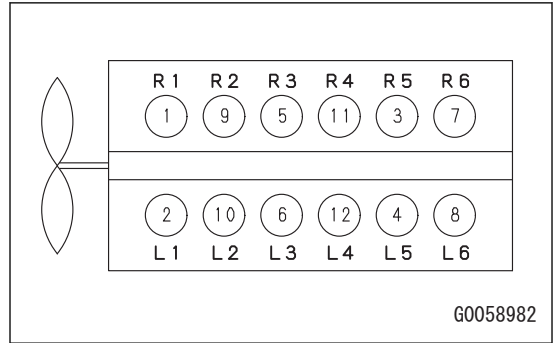

G0058982

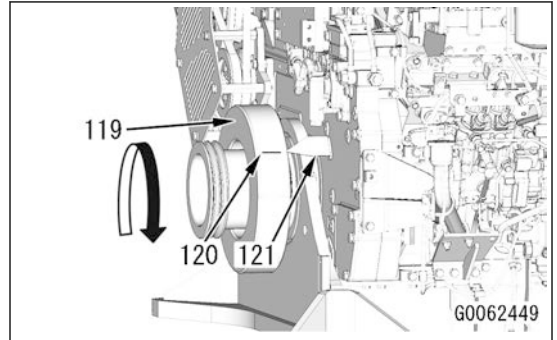

G0062449

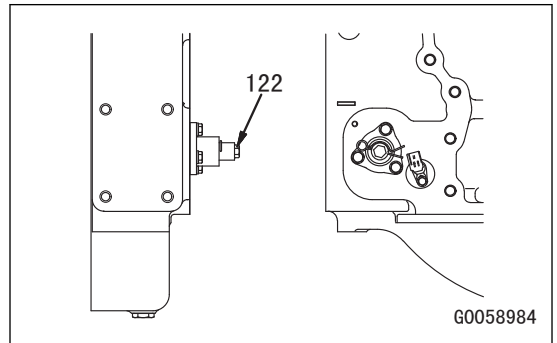

G0058984

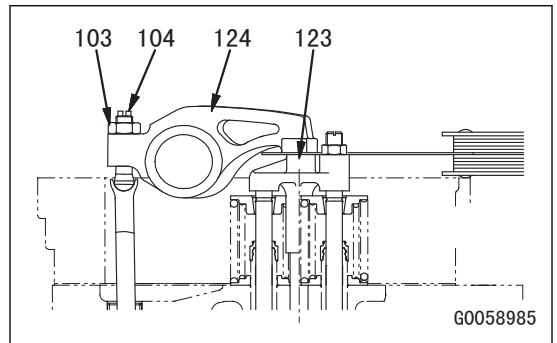

G0058985

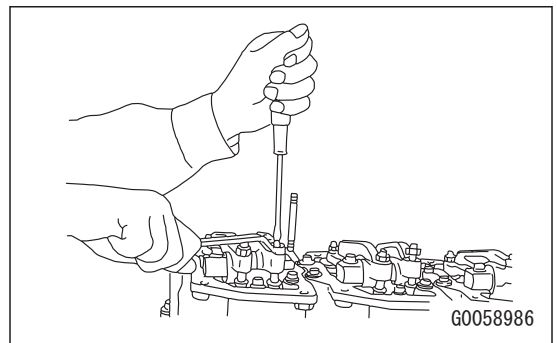

G0058986

REMOVE AND INSTALL INJECTOR ASSEMBLY (LEFT BANK)

41. Insert hose (43).

42. Insert hose (41).

Tool: Ratchet handle, socket

Clamp (40): Width across flats 7 mm

43. Install clamp (39).

Tool: Ratchet handle, socket, torque wrench

Bolt for clamp (39): Width across flats 19 mm, M12

 Bolt for clamp (39):  
98 to 123 Nm {10 to 12.5 kgfm}

44. Tighten the clamps (40) and (42).

**REMARK**

Install clamp (42) in the rotation range of (d) as shown in the figure so that it does not touch wiring harness connector.

Rotation range (d): 0 to 15 °

Tool: Ratchet handle, socket, torque wrench

Clamp (40), (42): Width across flats 7 mm

 Clamp (40), (42):  
4.4±0.49 Nm {0.45±0.05 kgfm}

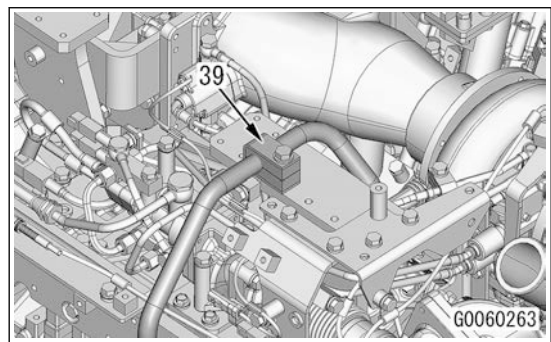
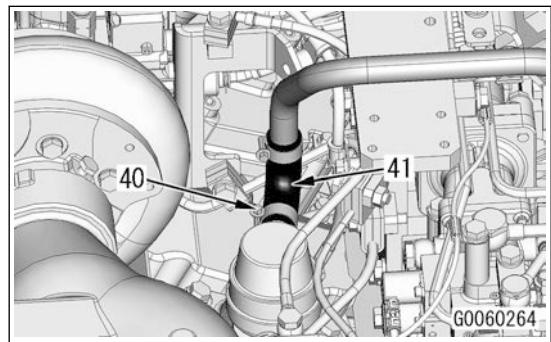
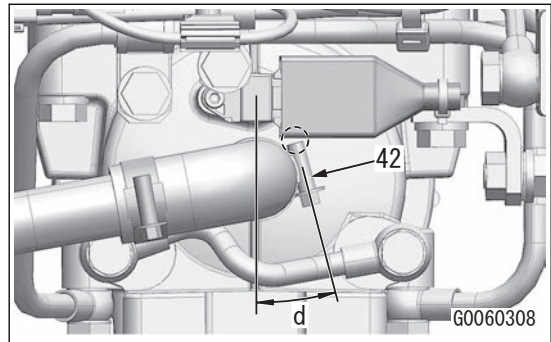
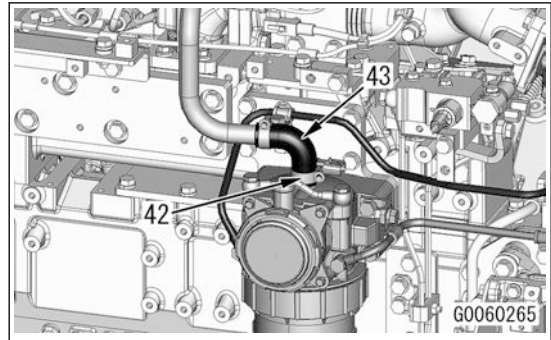

96. Remove joint bolt (417), and remove fuel doser water tube (418).

Tool: Impact wrench, socket

Joint bolt (417): Width across flats 19 mm, M14

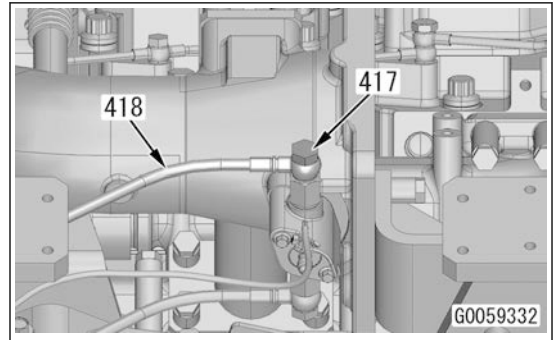

97. Remove clamp (419).

Tool: Impact wrench, socket

Bolt for clamp (419): Width across flats 17 mm, M10

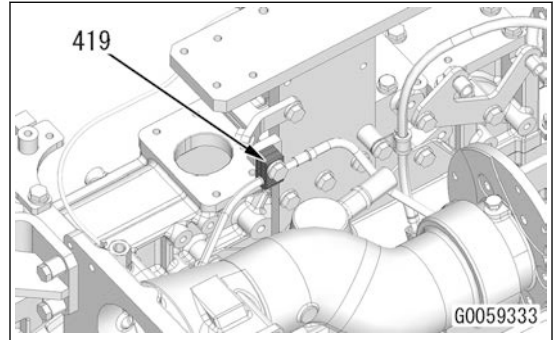

98. Remove joint bolt (420), and remove fuel doser water tube (421).

Tool: Impact wrench, socket

Joint bolt (420): Width across flats 19 mm, M14

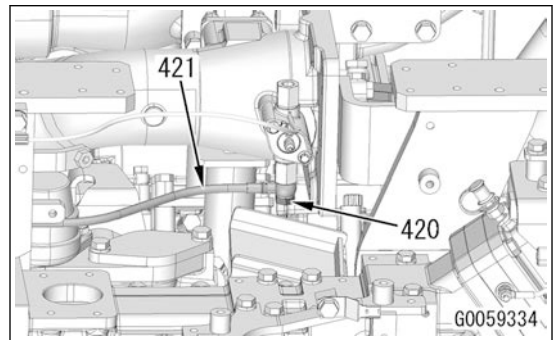

99. Remove clamp (643).

Tool: Impact wrench, socket

Bolt for clamp (643): Width across flats 17 mm, M10

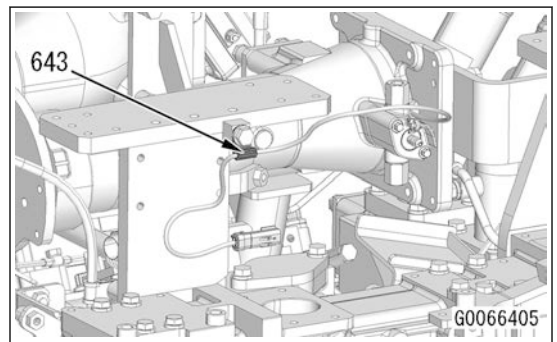

REMOVE AND INSTALL CYLINDER HEAD ASSEMBLY (RIGHT BANK)

 Bolt for clamp (472):  
11.7 to 14.7 Nm {1.2 to 1.5 kgfm}

78. Fasten clamp (468) to the specified torque.  
Tool: Ratchet handle, socket, torque wrench  
Bolt for clamp (468): Width across flats 10 mm, M6

 Bolt for clamp (468):  
11.7 to 14.7 Nm {1.2 to 1.5 kgfm}

79. Tighten bolt (473) to the specified torque.  
Tool: Ratchet handle, socket, torque wrench  
Bolt (473): Width across flats 17 mm, M6

Nut (474): Width across flats 17 mm

 Bolt (473):  
59 to 74 Nm {6 to 7.5 kgfm}

80. Tighten bolt (495) to the specified torque.  
Tool: Ratchet handle, socket, torque wrench  
Bolt (495): Width across flats 17 mm, M6

 Bolt (495):  
59 to 74 Nm {6 to 7.5 kgfm}

81. Tighten bolts (469) (2 pieces) to the specified torque.  
Tool: Ratchet handle, socket, torque wrench  
Bolt (469): Width across flats 17 mm, M10

 Bolt (469):  
59 to 74 Nm {6 to 7.5 kgfm}

82. Install bracket (467) with bolts (466) (2 pieces).  
Tool: Ratchet handle, socket, torque wrench  
Bolt (466): Width across flats 17 mm, M10

 Bolt (466):  
59 to 74 Nm {6 to 7.5 kgfm}

83. Install cover (464) and bracket (465) together as a unit with bolts (463) (2 pieces).

Tool: Ratchet handle, socket, torque wrench  
Bolt (463): Width across flats 17 mm, M10

 Bolt (463):  
59 to 74 Nm {6 to 7.5 kgfm}

84. Lightly fasten plate (462) with bolts (460) (2 pieces).

**REMARK**

Spacers (461) (2 pieces) and plate (462) are tightened together.

Tool: Impact wrench, socket  
Bolt (460): Width across flats 17 mm, M10

 Threaded portion and seat surface of bolt (460):  
Seizure prevention compound (LC-G)

85. Lightly fasten cover (459) with bolts (458) (2 pieces).  
Tool: Impact wrench, socket

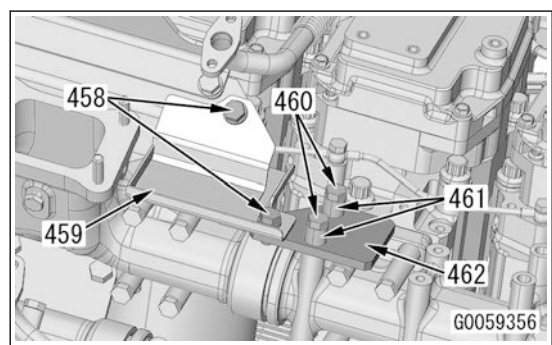
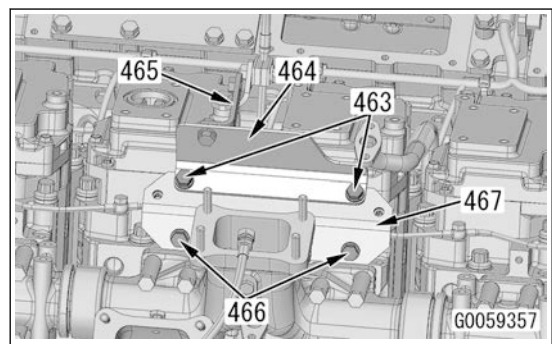

- 57. Remove boots (120) (2 pieces) from connectors ECM\_L\_J2 (121) and ECM\_L\_J1 (122).
- 58. Remove bolt (123), and disconnect ground terminal.

**REMARK**

Ground terminal, engine controller, and bracket are tightened together.

Tool: Impact wrench, socket

Bolt (123): Width across flats 13 mm, M8

- 59. Remove hexagonal socket head bolts (124), (125), and (126) in this order.

**REMARK**

Note that the length of each hexagonal socket head bolt are different.

Tool: Impact wrench, hexagonal wrench

Hexagonal socket head bolt (124), (125), (126): Width across flats 5 mm, M6

- 60. Disconnect connectors ECM\_L\_J2 (121) and ECM\_L\_J1 (122) from engine controller according to the following procedure.

**REMARK**

Disconnect connectors CM\_L\_J2 (121) and ECM\_L\_J1 (122) in this order.

- 1) While pressing the part (aa) of the connector, move lock lever (ab) in the direction of (ac), and release the lock.
- 2) Disconnect the connector in the direction of (ad).

- 61. Disconnect engine harness (127).

**REMARK**

Move the engine harness (127) to a safe place where it does not interfere with the work.

- 62. Remove bolts (141) (4 pieces), and remove heat insulation cover (142).

Tool: Impact wrench, socket

Bolt (141): Width across flats 17 mm, M10

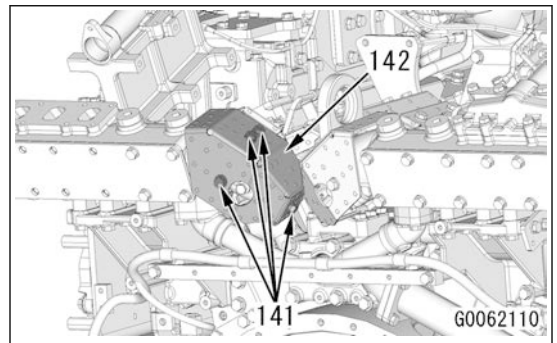
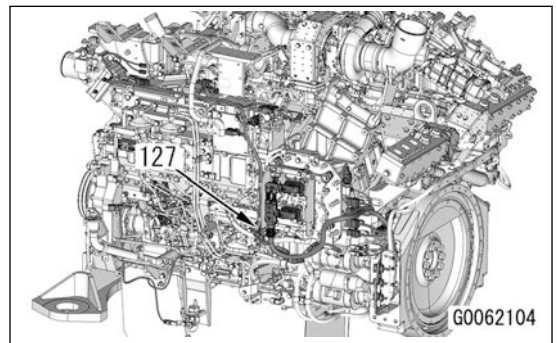
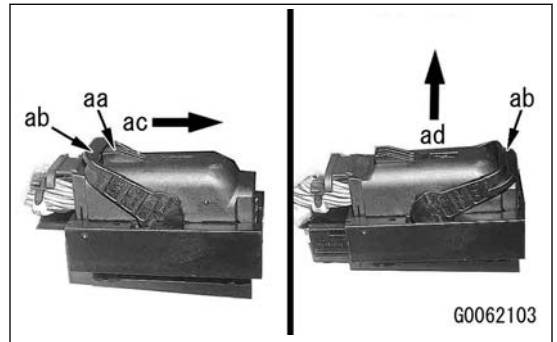
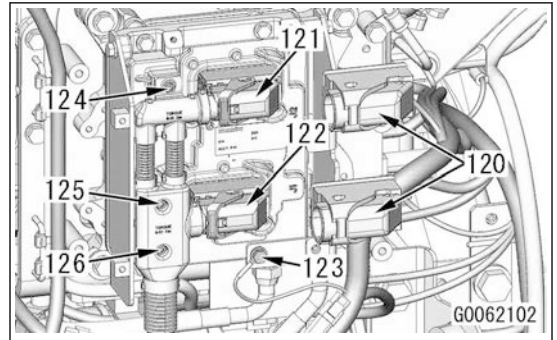

REMOVE AND INSTALL CYLINDER HEAD ASSEMBLY (LEFT BANK)

15. Install gaskets (612) (6 pieces) to cylinder head covers (607), (608) and rocker housings (610) (4 pieces).

**NOTICE**

Check that gasket groove is free from foreign material or scratch before installation.

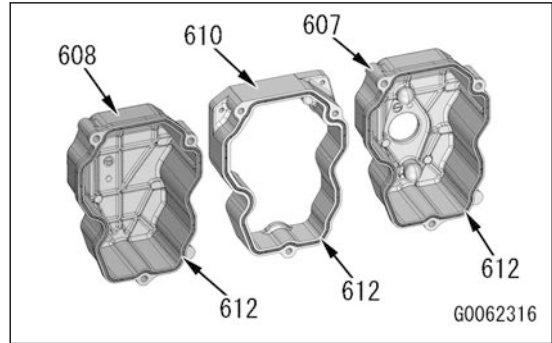

16. Install gaskets (611) (4 pieces) to cylinder head covers (602) (2 pieces) and (603) (2 pieces).

**NOTICE**

Check that gasket groove is free from foreign material or scratch before installation.

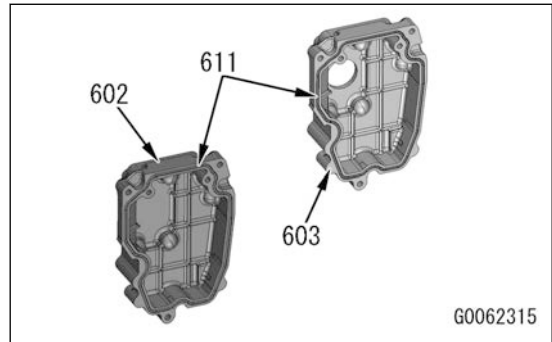

17. Install cylinder head cover according to the following procedure.

**NOTICE**

Check that cylinder head top surface is free from scratch, clean it by using a dry cloth, and remove foreign material.

**REMARK**

- Be careful not to drop gasket.
- Install cylinder head cover and cylinder head as the same set when disassembled.
- Check position of dowel pin before installation of cylinder head cover of No.2, 3, 5, and 6 cylinders.

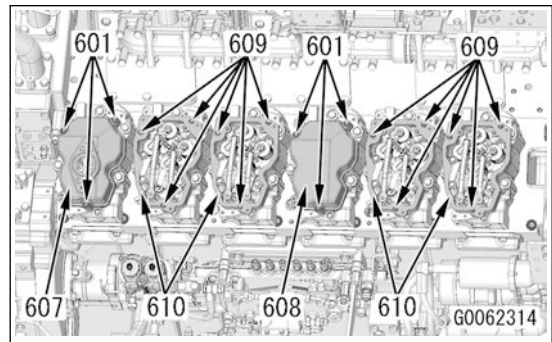

- 1) Install rocker housings (610) (4 pieces) with bolts (609) (12 pieces).

**REMARK**

Install bolt (609) by using socket (dodecagonal).

Tool: Ratchet handle, socket (dodecagonal), torque wrench

Bolt (609): Width across flats 8 mm, M8

 Bolt (609):  
29.4 to 34.3 Nm {3.0 to 3.5 kgfm}

- 2) Install cylinder head covers (607) and (608) with bolts (601) (6 pieces).

Tool: Ratchet handle, socket, torque wrench

Bolt (601): Width across flats 12 mm, M8

 Bolt (601):  
29.4 to 34.3 Nm {3.0 to 3.5 kgfm}

230. Connect connectors PDOSER\_L (73), DSOV1\_L (74), and DSOV2\_L (75) according to the following procedure.

- 1) Insert connector (d) until a click sound is heard, slide lock in the direction of (e), and lock it.

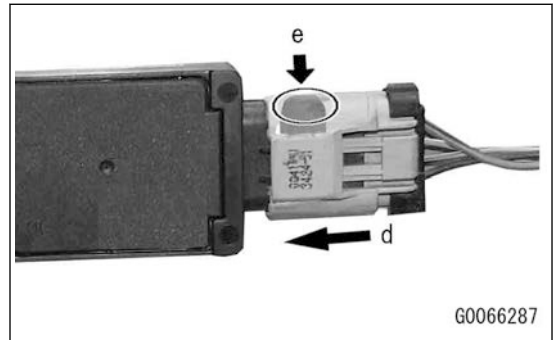
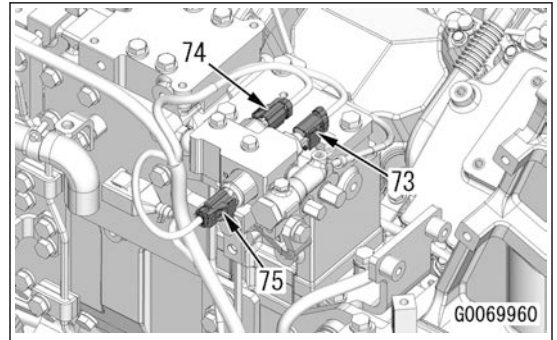

231. Place boots (78), (79), and (80).

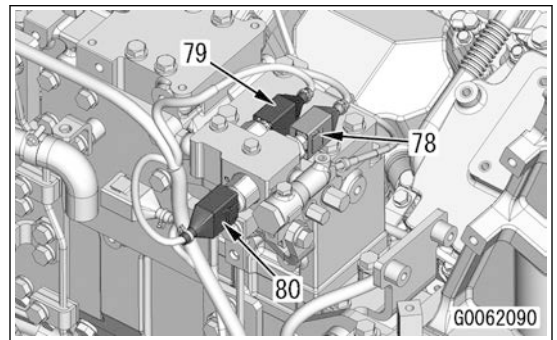

232. Install clamps (67) (2 pieces), (68), and (69).

Tool: Ratchet handle, socket, torque wrench

Bolt for clamp (67), (68), (69): Width across flats 17 mm, M10

-  Bolt for clamp (67), (68), (69):  
59 to 74 Nm {6 to 7.5 kgfm}

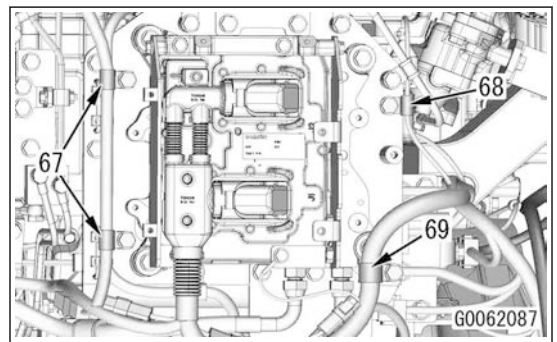

233. Install clamp (64).

**REMARK**

Spacer (65) and clamp (64) are tightened together.

Tool: Ratchet handle, socket, torque wrench

Bolt for clamp (64): Width across flats 17 mm, M10

-  Bolt for clamp (64):  
59 to 74 Nm {6 to 7.5 kgfm}

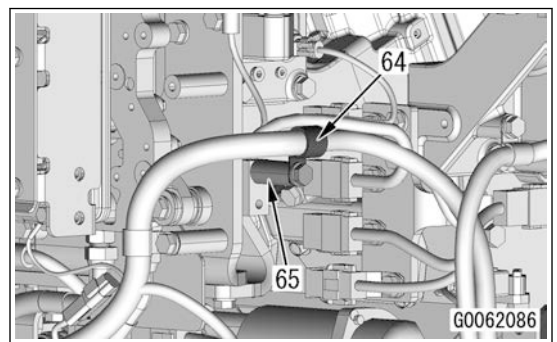

## REMOVE AND INSTALL EGR VALVE ASSEMBLY (LEFT BANK)

- ⚠ Park the machine on level ground, lower the work equipment to the ground and keep it in a stable position, and set the work equipment lock lever to LOCK position.
- ⚠ Stop the engine, set the battery isolator switch to OFF position, and take out the starting switch key. (For details, see TESTING AND ADJUSTING, “HANDLE BATTERY ISOLATOR AND STARTING MOTOR ISOLATOR”.)

### NOTICE

- Before disconnecting the wirings and hoses, check the connector numbers and installed positions, and record them.
- Prevent oil from flowing out.
- Replace seal washer with a new one.
- Replace O-ring and gasket with new ones.

## METHOD FOR REMOVING EGR VALVE ASSEMBLY (LEFT BANK)

### Engine hood assembly

1. Remove engine hood assembly. For details, see “REMOVE AND INSTALL ENGINE HOOD ASSEMBLY”.

### Air cleaner assembly

2. Remove clamps (1) (2 pieces), and disconnect tubes (2) (2 pieces).

Tool: Ratchet wrench, socket

Clamp (1): Width across flats 7 mm

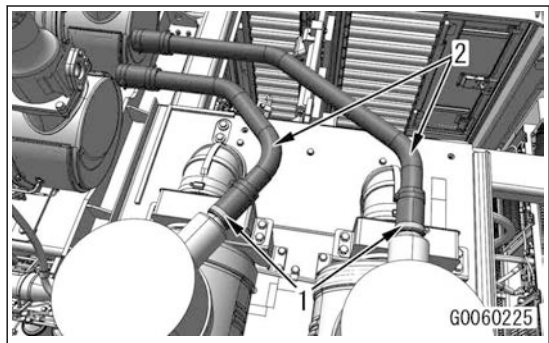

3. Disconnect connectors P23A (3) and P23B (4).

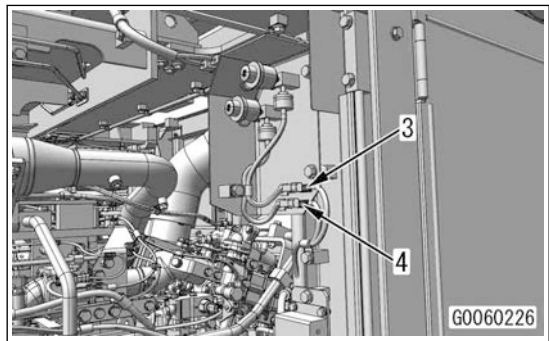

4. Remove clamps (5) (2 pieces).

Tool: Impact wrench, socket

Bolt for clamp (5): Width across flats 19 mm, M12

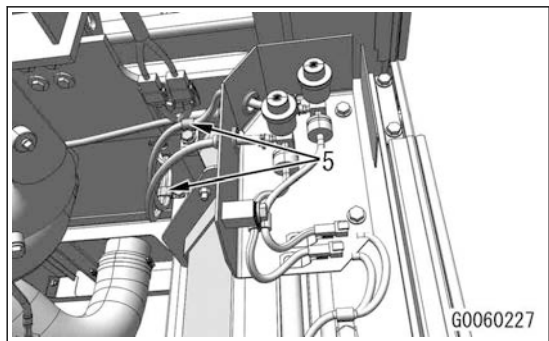

55. Remove clamps (75) (2 pieces).

Tool: Impact wrench, socket

Bolt for clamp (75): Width across flats 17 mm, M10

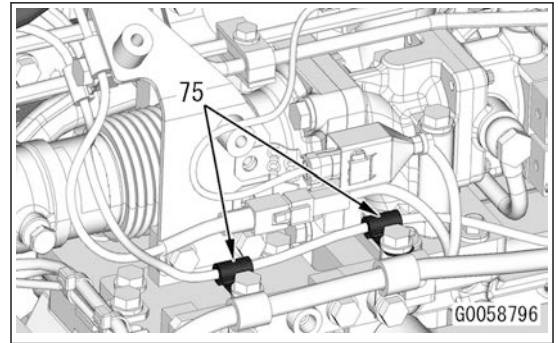

56. Remove clamps (78) (2 pieces).

**REMARK**

Move the VGT speed sensor harness (80) and VGT position sensor harness (81) to a safe place where they do not interfere with the work.

Tool: Impact wrench, socket

Bolt for clamp (78): Width across flats 17 mm, M10

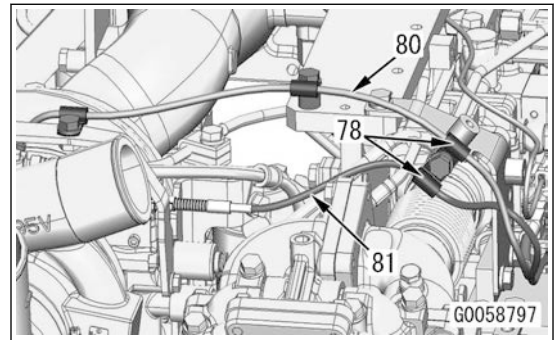

57. Remove bolts (82) (3 pieces), and remove bracket (83).

Tool: Impact wrench, socket

Bolt (82): Width across flats 17 mm, M10

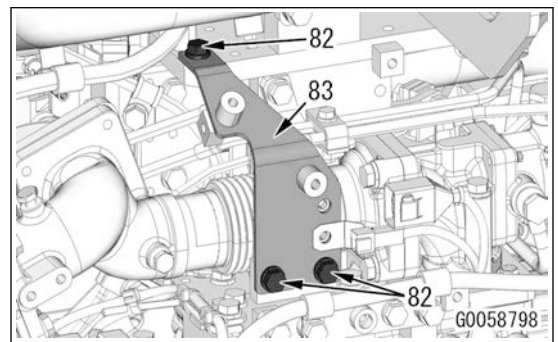

58. Remove clamps (228) and (229) (2 pieces).

Tool: Impact wrench, socket

Bolt for clamp (228), (229): Width across flats 17 mm, M10

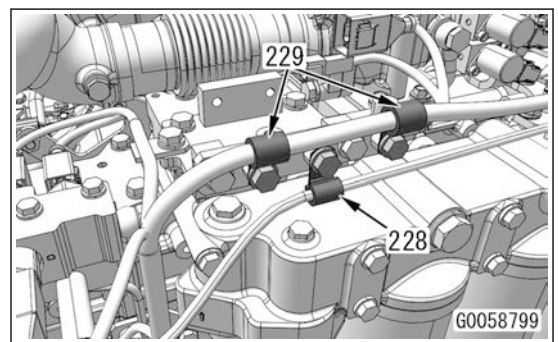

59. Remove bolts (84) (2 pieces), and remove bracket (85) and brackets (86) and (87) together as a unit.

Tool: Impact wrench, socket

Bolt (84): Width across flats 17 mm, M10

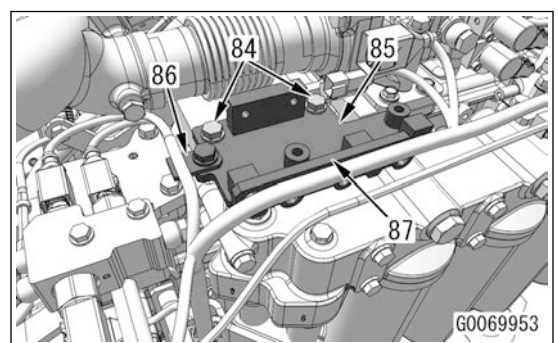

REMOVE AND INSTALL EGR COOLER ASSEMBLY (RIGHT BANK)

**Air cleaner assembly**

157. Sling air cleaner assembly (11), and install it with bolts (10) (6 pieces).

Tool: Ratchet wrench, socket, torque wrench, wire sling

Bolt (10): Width across flats 19 mm, M12

 Air cleaner assembly (11):  
135 kg

 Bolt (10):  
98 to 123 Nm {10.0 to 12.5 kgfm}

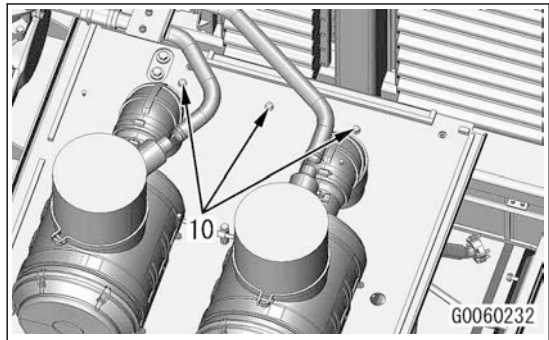
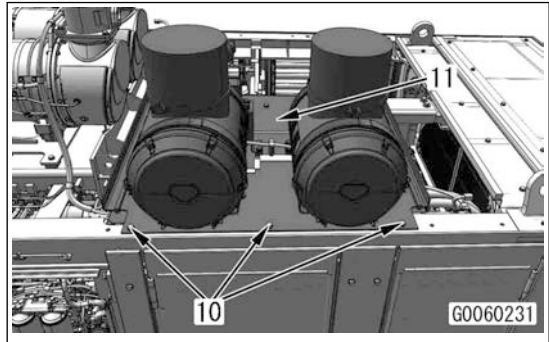

158. Connect connector A67 (9).

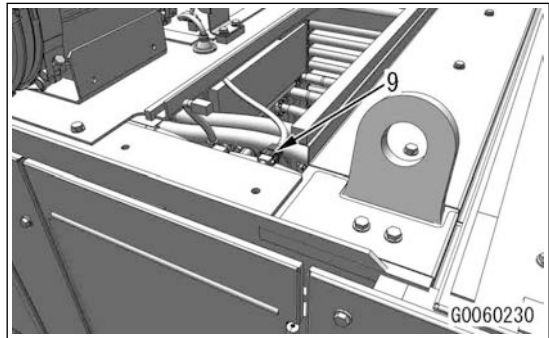

159. Connect hoses (8) (2 pieces) with clamps (7) (4 pieces).

Tool: Ratchet wrench, socket, torque wrench

Clamp (7): Width across flats 11 mm

 Clamp (7):  
10.5±0.5 Nm {1.07±0.05 kgfm}

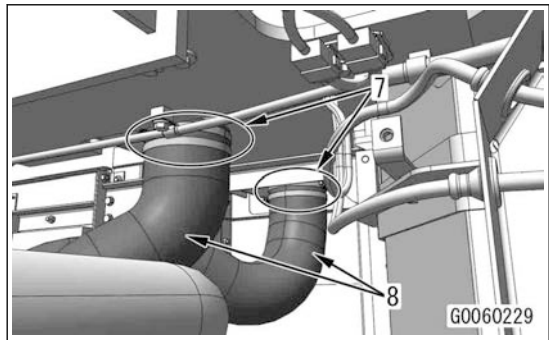

160. Install bolts (6) (2 pieces).

Tool: Ratchet wrench, socket, torque wrench

Bolt (6): Width across flats 19 mm, M12

 Bolt (6):  
98 to 123 Nm {10.0 to 12.5 kgfm}

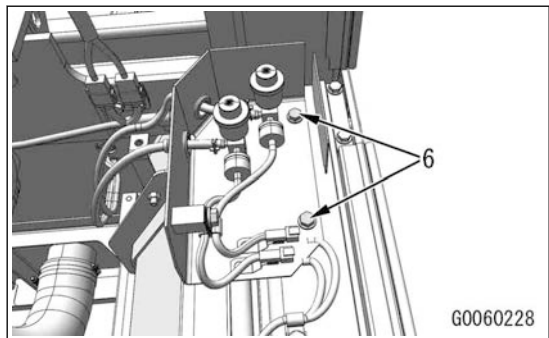

111. Install clamps (73) (2 pieces) and (74) (2 pieces).

**REMARK**

- Clamps (73) (2 pieces) and (74) (2 pieces) are tightened together respectively.
- Install exhaust gas temperature sensor harness at left bank to the bottom side (n), and install exhaust gas temperature sensor harness at right bank to the top side (o).

Tool: Ratchet handle, socket, torque wrench

Bolt for clamp (73), (74): Width across flats 17 mm, M10

 Bolt for clamp (73), (74):  
59 to 74 Nm {6 to 7.5 kgfm}

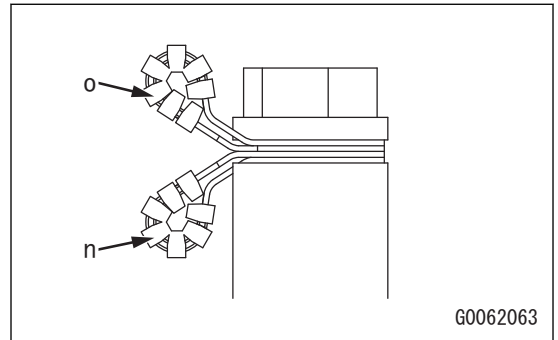
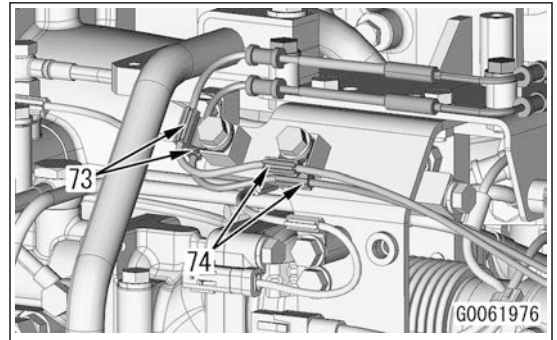

112. Install clamps (69) (2 pieces) and (70) (2 pieces).

**REMARK**

- Clamps (69) (2 pieces) and (70) (2 pieces) are tightened together respectively.
- Install exhaust gas temperature sensor harness at left bank to the inner side (p), and install exhaust gas temperature sensor harness at right bank to the outer side (q).

Tool: Ratchet handle, socket, torque wrench

Bolt for clamp (69), (70): Width across flats 17 mm, M10

 Bolt for clamp (69), (70):  
59 to 74 Nm {6 to 7.5 kgfm}

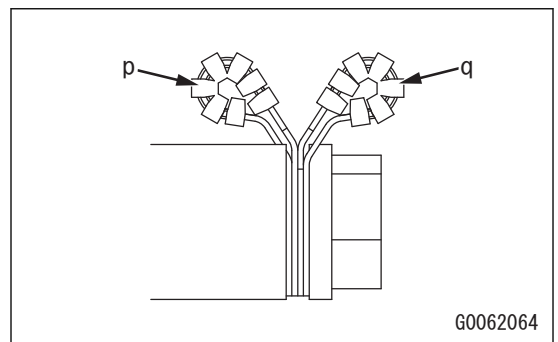
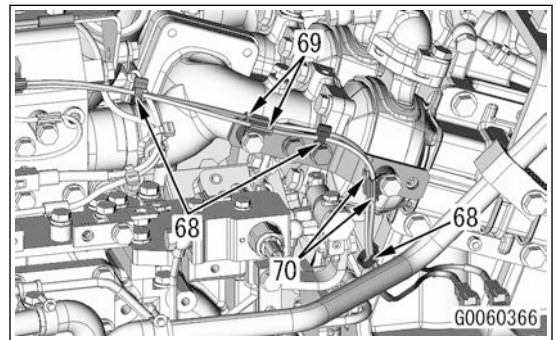

113. Install bands (68) (3 pieces).

**REMARK**

Adjust position of band, and install it so that exhaust gas temperature sensor harness does not interfere with parts around.

Tool: Nippers

## REMOVE AND INSTALL HYDRAULIC OIL COOLER ASSEMBLY

### Tools for removing and installing the hydraulic oil cooler assembly

Symbol	Part No.	Part name	Necessity	Q'ty	New/Redesign	Sketch	Remarks
A	Commercially available	Guide bolt (M10 × 190 mm)	■	1			

**⚠** Park the machine on level ground, lower the work equipment to the ground and keep it in a stable position, and set the work equipment lock lever to LOCK position.

**⚠** Release remaining pressure in the hydraulic circuit. For details, see TESTING AND ADJUSTING, "RELEASING REMAINING PRESSURE FROM HYDRAULIC SYSTEM".

### NOTICE

- Fit a plug or flange in the place where a hydraulic hose is disconnected to prevent oil from flowing out.
- Before disconnecting wires and hoses, check and note the connector numbers and installed positions.

## METHOD FOR REMOVING HYDRAULIC OIL COOLER ASSEMBLY

### Service arm

1. Run the engine at low speeds, retract the arm and bucket cylinder rods, lower the boom to set the bucket teeth in contact with the ground, and stop the engine.
2. Turn the starting switch to ON position within 15 seconds after stopping the engine, and move each control lever (for work equipment and travel) to its respective stroke end in order to release the internal pressure.
3. Set the lock lever to LOCK position.

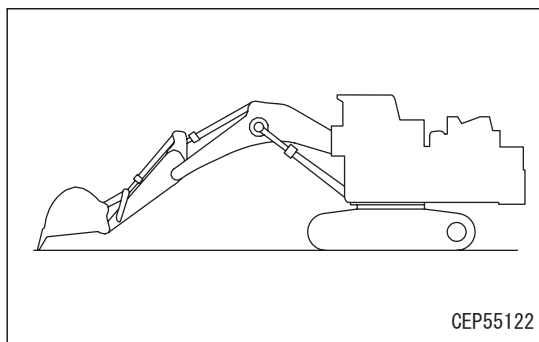

### Draining hydraulic oil

4. Open the oil filler port (1) of the hydraulic tank.

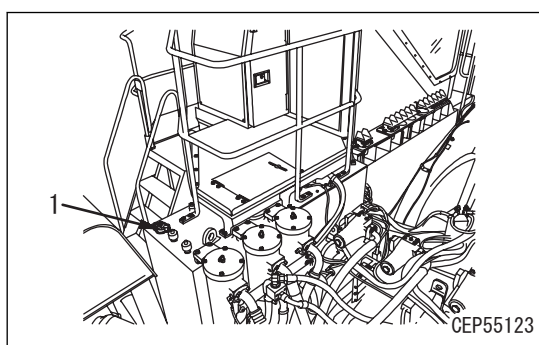

91. Open the cover (117).

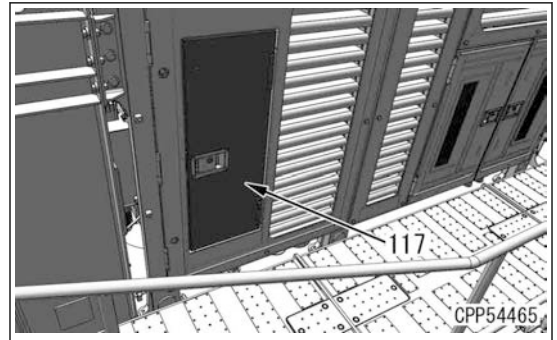

92. Remove the clamps (118) (3 pieces).  
Tool: Impact wrench, socket wrench  
Bolt for clamp (118): Width across flats 19 mm, M12

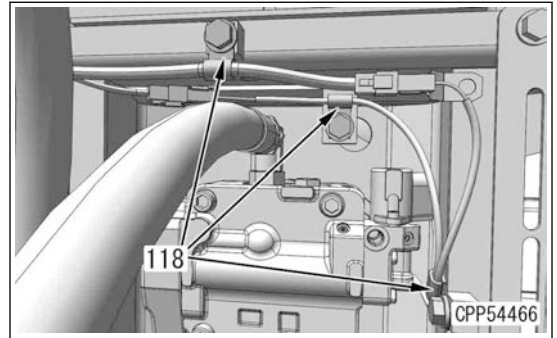

93. Disconnect the connectors V17 (119) and P51 (120).  
94. Remove the connectors V17 (121) and P51 (122) from the connector stand.

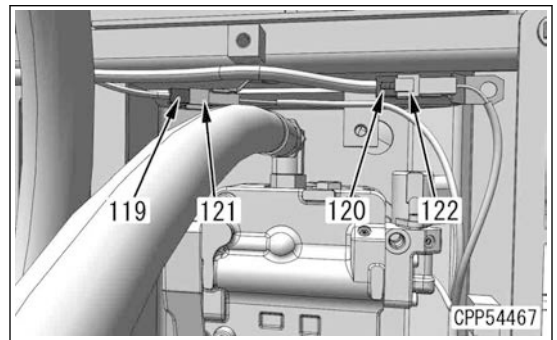

95. Remove the clamps (123) (6 pieces).  
Tool: Impact wrench, socket wrench  
Bolt for clamp (123): Width across flats 19 mm, M12

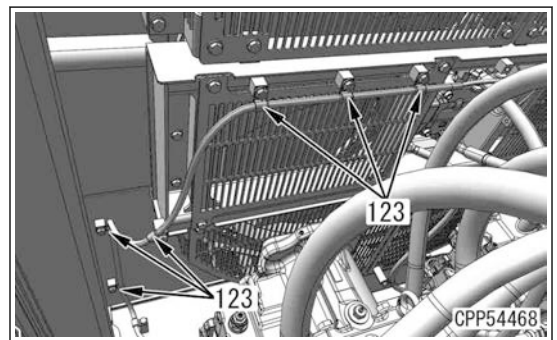

96. Remove the clamps (124) (2 pieces).  
Tool: Impact wrench, socket wrench  
Bolt for clamp (124): Width across flats 19 mm, M12

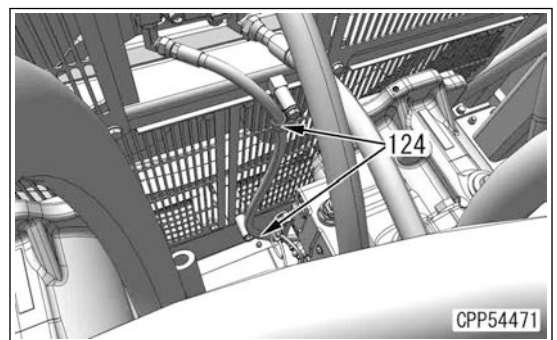

REMOVE AND INSTALL POWER MODULE PACKAGING ASSEMBLY

47. Remove the nuts (46) (4 pieces), and remove the brackets (47) (2 pieces).

Tool: Impact wrench, socket, wrench

Nut (46): Width across flats 17 mm, M10

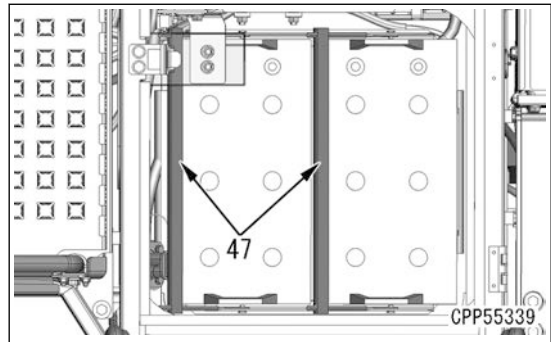
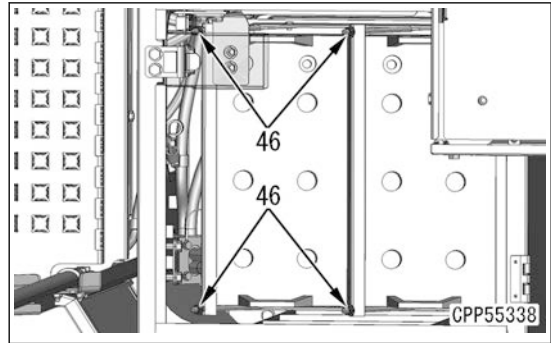

48. Remove the batteries (48) (2 pieces).

Tool: Webbing sling



Battery (48):

70 kg

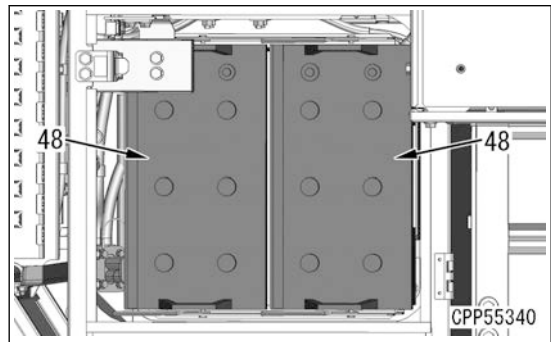

49. Remove the covers (49) (2 pieces).

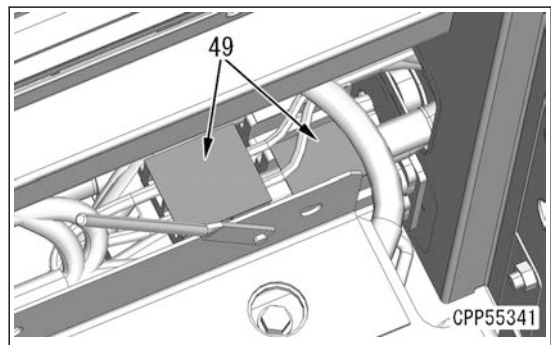

50. Remove the bolts (50) (2 pieces), and disconnect the terminals (2 pieces).

Tool: Impact wrench, socket

Bolt (50): Width across flats 13 mm, M8

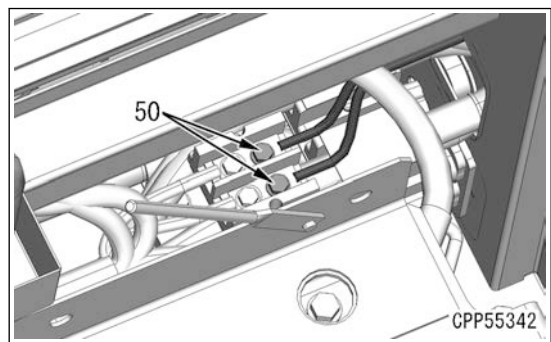

76. Disconnect connector M35 (94) and connector M34 (95).

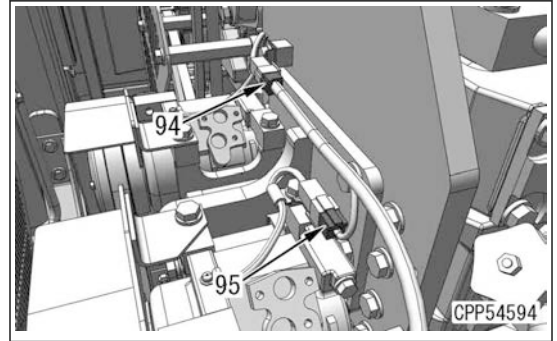

77. Remove bolts (96) (4 pieces) to remove cover (97).

Tool: Impact wrench, socket wrench

Bolt (96): Width across flats 19 mm, M12

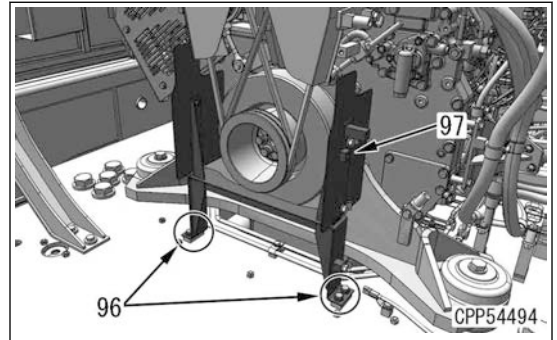

**Hose**

78. Remove clamp (98).

Tool: Impact wrench, socket wrench

Bolt for clamp (98): Width across flats 19 mm, M12

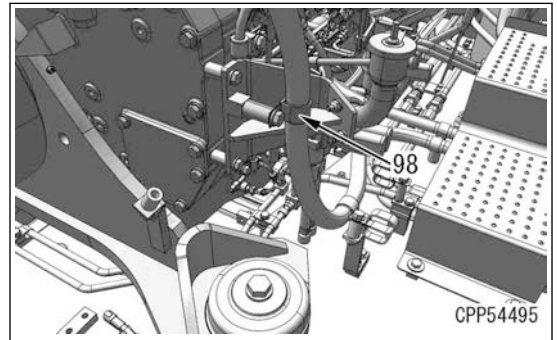

79. Remove clamps (99) and disconnect hose (100).

Tool: Ratchet handle, socket wrench

Clamp (99): Width across flats 7 mm

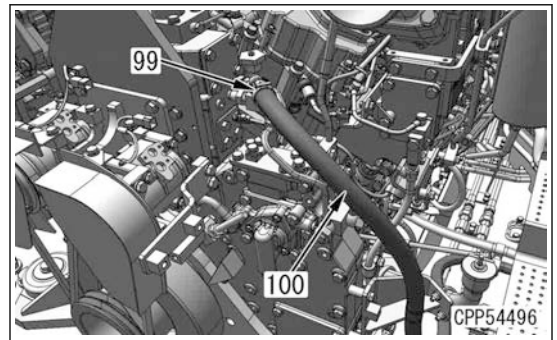

80. Loosen the sleeve nuts and disconnect hoses (101) (2 pieces).

**REMARK**

Fit a plug or cap to the disconnected hose and port to prevent oil from flowing out.

Tool: Spanner wrench

Hose (101): Width across flats 27 mm, Size #04

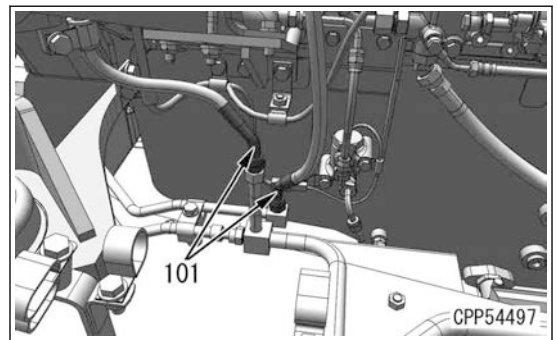

REMOVE AND INSTALL ENGINE PTO AND HYDRAULIC ASSEMBLY

103. Use bolts (54) (5 pieces) to install fan guard (55).  
 Tool: Ratchet handle, socket wrench, torque wrench  
 Bolt (54): Width across flats 19 mm, M12

 Bolt (54) :  
 98 to 123 Nm {10.0 to 12.5 kgfm}

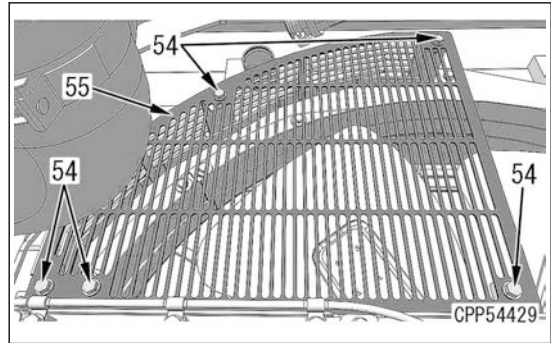

104. Use bolts (52) (5 pieces) to install fan guard (53).  
 Tool: Ratchet handle, socket wrench, torque wrench  
 Bolt (52): Width across flats 19 mm, M12

 Bolt (52) :  
 98 to 123 Nm {10.0 to 12.5 kgfm}

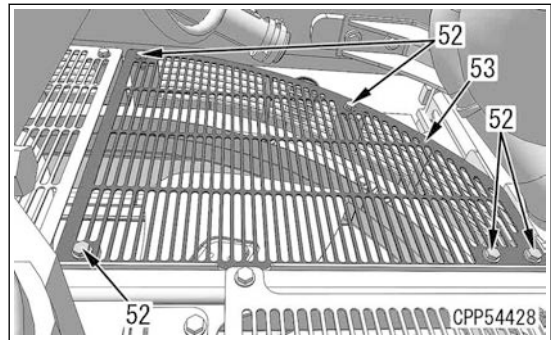

105. Connect tube (51) according to the following procedure.

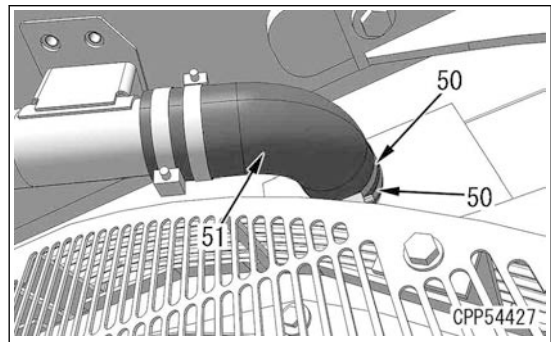

- 1) Connect the tube, aligning its end with the mark.

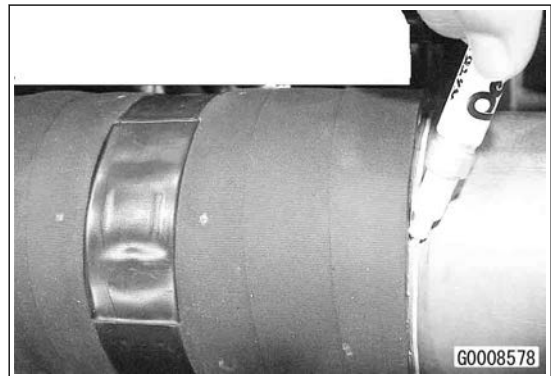

- 2) Set the MIKAROL clamp with its bridge (a) under bolt (d), and tighten the bolt so that overlap dimension (c) between bridge (a) and band (b) is 5 mm or above.

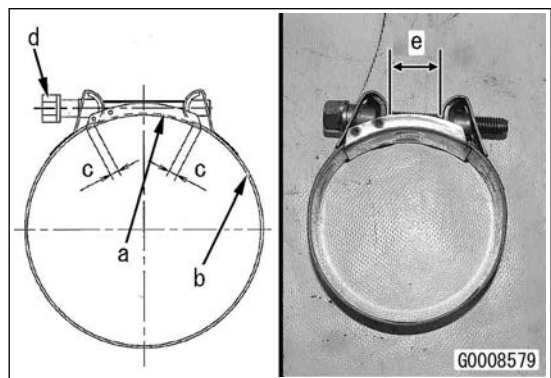

20. Remove bolts (27) (10 pieces) to remove left engine hood assembly (28) by lifting it up.

Tool: Lifting tool, impact wrench, socket

Bolt (27): Width across flats 19 mm, M12

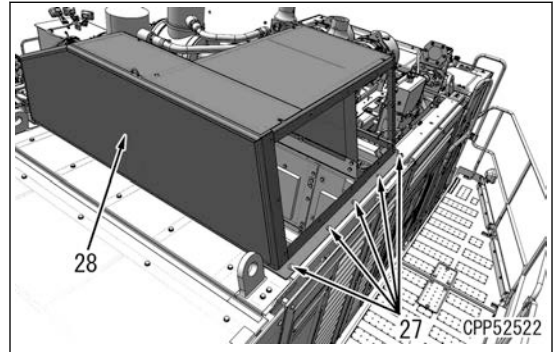
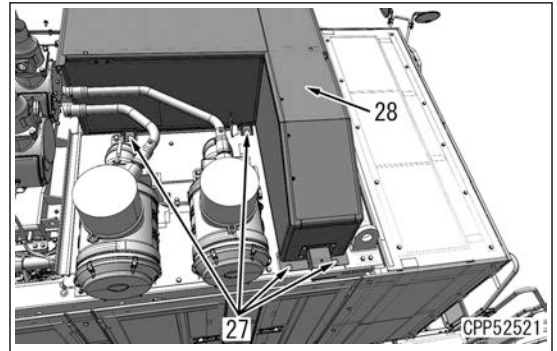

## METHOD FOR INSTALLING ENGINE HOOD ASSEMBLY

### Left engine hood assembly

1. Sling left engine hood assembly (28), and set the assembly to its installed position.

Tool: Wire sling

2. Use bolts (27) (10 pieces) to install left engine hood assembly (28).

Tool: Impact wrench, socket, torque wrench

Bolt (27): Width across flats 19 mm, M12

 Bolt (27) :  
98 to 123 Nm {10.0 to 12.5 kgfm}

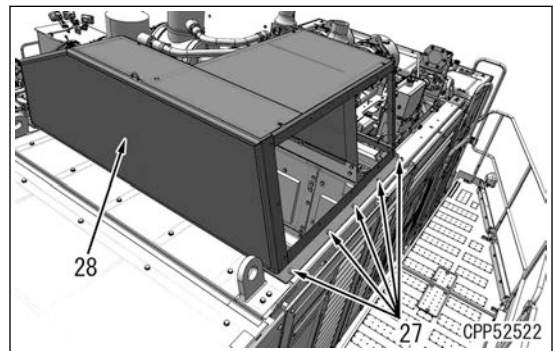
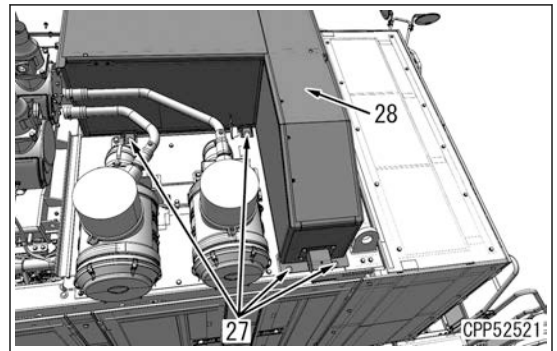

REMOVE AND INSTALL KCCV ASSEMBLY (RIGHT BANK)

- Remove bolt (17), and remove bracket (18).

**REMARK**

Bracket (18) and KCCV assembly (20) are tightened together.

Tool: Impact wrench, socket

Bolt (17): Width across flats 17 mm, M10

- Remove bolts (19) (3 pieces), and remove KCCV assembly (20).

Tool: Impact wrench, socket

Bolt (19): Width across flats 17 mm, M10

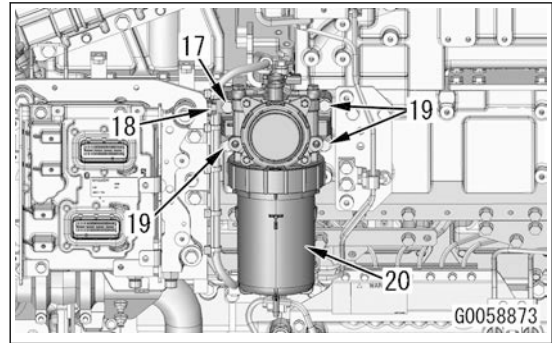

**METHOD FOR INSTALLING KCCV ASSEMBLY (RIGHT BANK)**

**KCCV assembly**

- Install KCCV assembly (20) with bolts (19) (3 pieces).

Tool: Ratchet handle, socket, torque wrench

Bolt (19): Width across flats 17 mm, M10

 Bolt (19):  
59 to 74 Nm {6 to 7.5 kgfm}

- Install bracket (18) with bolt (17).

**REMARK**

Bracket (18) and KCCV assembly (20) are tightened together.

Tool: Ratchet handle, socket, torque wrench

Bolt (17): Width across flats 17 mm, M10

 Bolt (17):  
59 to 74 Nm {6 to 7.5 kgfm}

- Lightly fasten tube (16) with joint bolt (15).

Tool: Impact wrench, socket

Joint bolt (15): Width across flats 17 mm, M12

- Fasten clamps (14) (2 pieces) lightly.

Tool: Impact wrench, socket

Bolt for clamp (14): Width across flats 17 mm, M10

- Tighten joint bolt (15) to the specified torque.

Tool: Ratchet handle, socket, torque wrench

Joint bolt (15): Width across flats 17 mm, M12

 Joint bolt (15):  
19.6 to 29.4 Nm {2.0 to 3.0 kgfm}

- Fasten clamps (14) (2 pieces) to the specified torque.

Tool: Ratchet handle, socket, torque wrench

Bolt for clamp (14): Width across flats 17 mm, M10

 Bolt for clamp (14):  
59 to 74 Nm {6 to 7.5 kgfm}

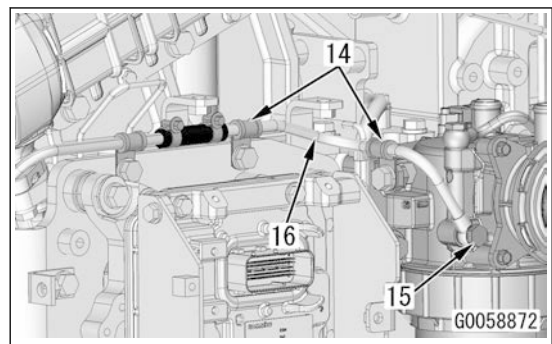
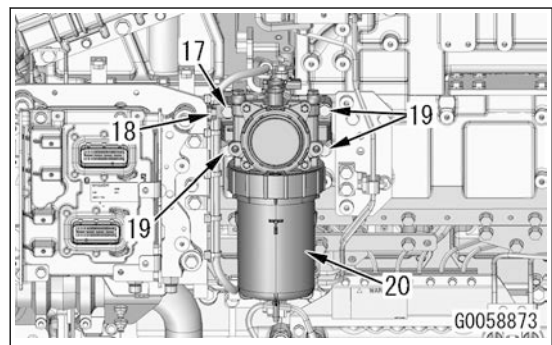

58. Install partition plate (32) with bolts (31) (8 pieces).

Tool: Ratchet handle, socket, torque wrench

Bolt (31): Width across flats 19 mm, M12

 Bolt (31):  
98 to 123 Nm {10.0 to 12.5 kgfm}

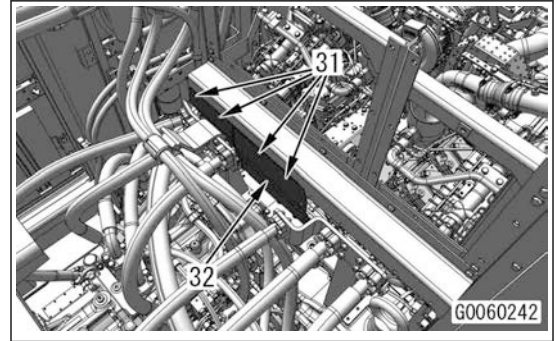

59. Install partition plate (30) with bolts (29) (9 pieces).

Tool: Ratchet handle, socket, torque wrench

Bolt (29): Width across flats 19 mm, M12

 Bolt (29):  
98 to 123 Nm {10.0 to 12.5 kgfm}

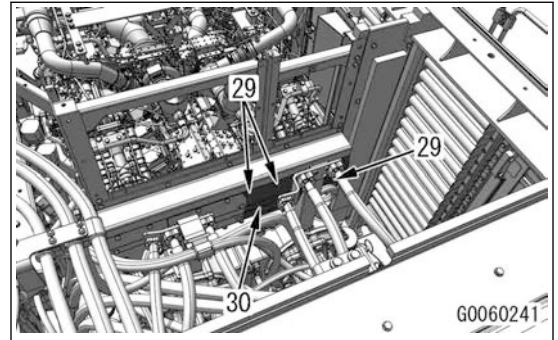

60. Install partition plate (28) with bolts (27) (8 pieces).

Tool: Ratchet handle, socket, torque wrench

Bolt (27): Width across flats 19 mm, M12

 Bolt (27):  
98 to 123 Nm {10.0 to 12.5 kgfm}

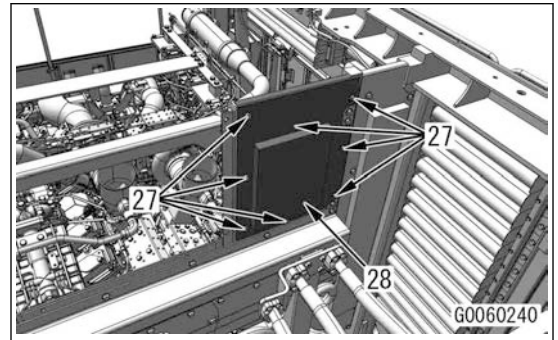

61. Install partition plate (26) with bolts (25) (8 pieces).

Tool: Ratchet handle, socket, torque wrench

Bolt (25): Width across flats 19 mm, M12

 Bolt (25):  
98 to 123 Nm {10.0 to 12.5 kgfm}

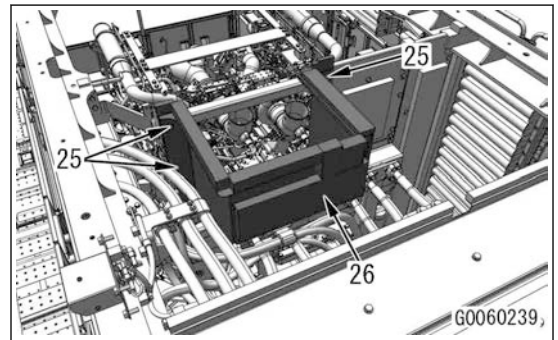

62. Sling frame (24), and install it with bolts (23) (4 pieces).

Tool: Ratchet handle, socket, torque wrench, wire sling

Bolt (23): Width across flats 19 mm, M12

 Frame (24):  
100 kg

 Bolt (23):  
98 to 123 Nm {10.0 to 12.5 kgfm}

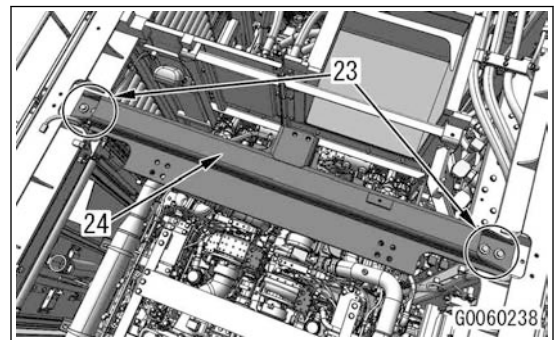

REMOVE AND INSTALL AIR CLEANER ASSEMBLY

7. Use bolts (9) (8 pieces) to install covers (10) (2 pieces).

Tool: Impact wrench, socket, torque wrench

Bolt (9): Width across flats 19 mm, M12

 Bolt (9) :  
98 to 123 Nm {10.0 to 12.5 kgfm}

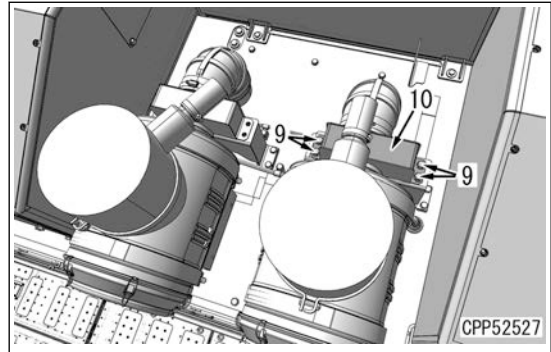
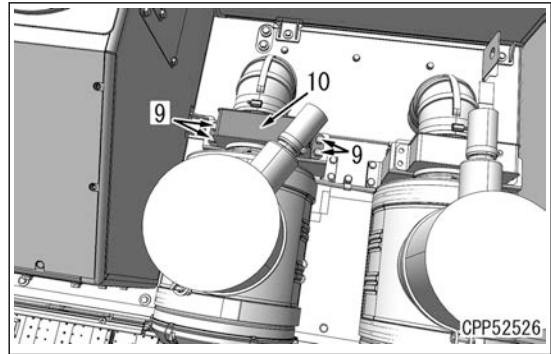

8. Connect tubes (8) (2 pieces) and install clamps (7) (2 pieces).

Tool: Ratchet handle, socket, torque wrench

Bolt for clamp (7): Width across flats 7 mm

 Bolt for clamp (7) :  
5.9 ± 0.5 Nm {0.6 ± 0.05 kgfm}

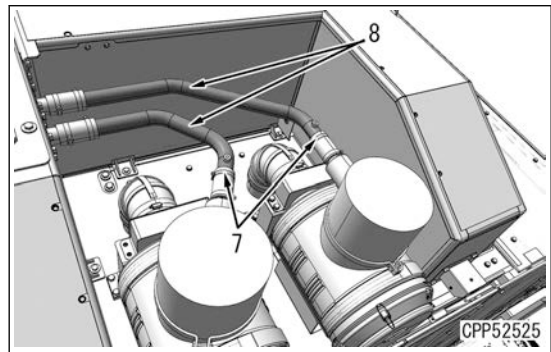

9. Use bolts (5) (2 pieces) to install bracket (6).

Tool: Impact wrench, socket, torque wrench

Bolt (5): Width across flats 19 mm, M12

 Bolt (5) :  
98 to 123 Nm {10.0 to 12.5 kgfm}

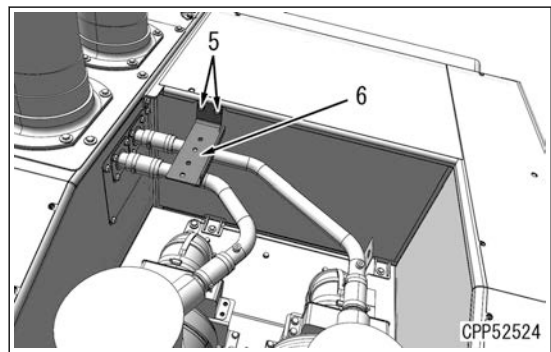

10. Use nuts (3) (4 pieces) to install U-bolts (4) (2 pieces).

Tool: Impact wrench, socket, torque wrench

U-bolt (4): Width across flats 17 mm, M10

 U-bolt (4) :  
11 to 28 Nm {1.12 to 2.86 kgfm}

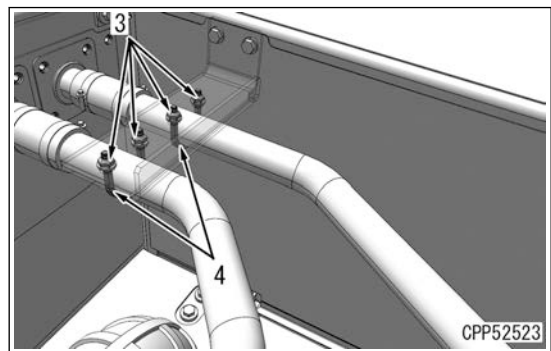

13. Remove the shim (40).

**REMARK**

Check the thickness and quantity of shims.

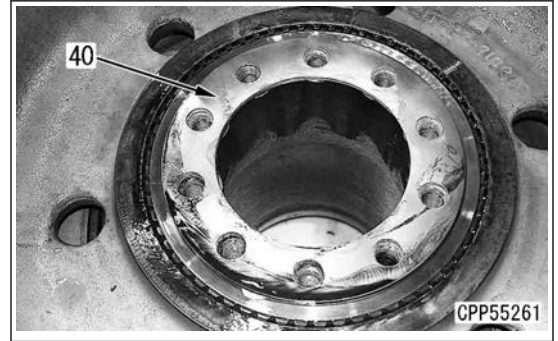

14. Sling the ring gear assembly (41), and remove it.

Tool: Lifting tool

 Ring gear assembly (41):  
220 kg

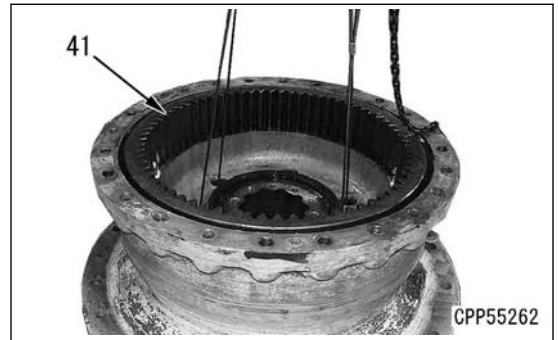

15. Remove the bolts (42a) (12 pieces) and lock plates (42) (6 pieces), and remove the case (44) from the ring gear (43).

**REMARK**

Put the matchmarks on the lock plate and ring gear before removing them.

Tool: Impact wrench, socket

Bolt (42a): Width across flats 19 mm, M12

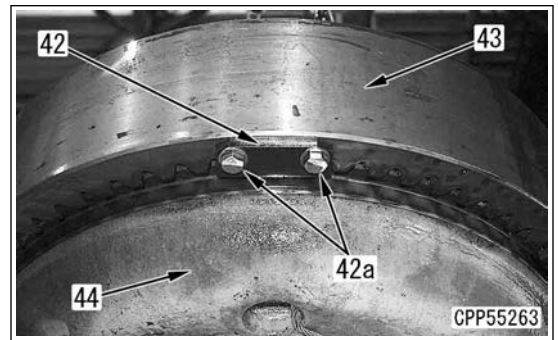

**Case assembly**

16. Remove the case assembly (45) from the housing assembly (46) by using the press.



17. Sling the case assembly (45), and remove it.

Tool: Lifting tool

 Case assembly (45):  
800 kg



## REMOVE AND INSTALL SWING CIRCLE ASSEMBLY

 Swing circle mounting face:  
Liquid gasket (LG-6)

 Swing circle internal tooth:  
Grease (G2-LI)

 Seal groove:  
Grease (G2-LI)

- Seal the oil bath grease.

**REMARK**

- The sealed amount of the oil bath grease (G2-LI: standard specification, GLT2-LI: extremely cold weather specification) is approximately 80 l.
- The capacity up to the internal tooth top surface is 500 l.

- Install the swing circle assembly (2) with the bolts (1) (60 pieces).

**REMARK**

Tighten the bolts (1) diagonally and evenly.

Tool: Ratchet handle, socket wrench, torque wrench

Bolt (1): Width across flats 55 mm, M36

 Bolt (1):  
Adhesive (LT-2)

 Bolt (1):  
2450 to 3040 Nm {250 to 310 kgfm}

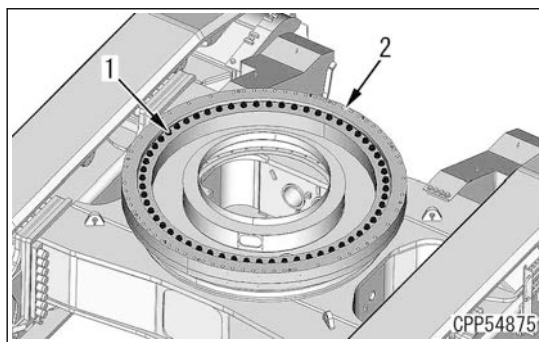
**Revolving frame assembly**

- Install the revolving frame assembly. See "REMOVE AND INSTALL REVOLVING FRAME ASSEMBLY".

7. Connect the connector L09B (9), and install the clamps (8) (11 pieces).

Tool: Impact wrench, socket, torque wrench

Bolt for clamp (8): Width across flats 19 mm, M12

 Bolt for clamp (8):  
98 to 123 Nm {10.0 to 12.5 kgfm}

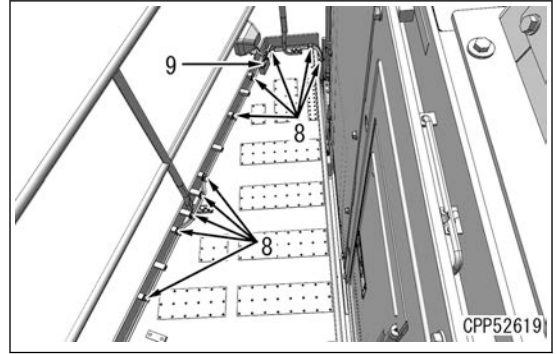

8. Connect the connectors CAM4 (6) and A49 (7), and install the clamps (5) (7 pieces).

Tool: Impact wrench, socket, torque wrench

Bolt for clamp (5): Width across flats 19 mm, M12

 Bolt for clamp (5):  
98 to 123 Nm {10.0 to 12.5 kgfm}

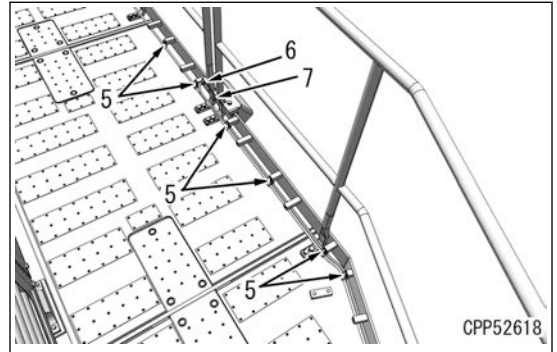

9. Connect the connector L09A (4), and install the clamps (3) (9 pieces).

Tool: Impact wrench, socket, torque wrench

Bolt for clamp (3): Width across flats 19 mm, M12

 Bolt for clamp (3):  
98 to 123 Nm {10.0 to 12.5 kgfm}

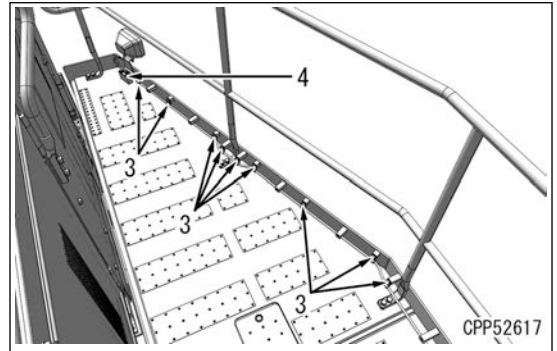

10. Install the covers (2) (6 pieces) with the bolts (1) (12 pieces).

Tool: Impact wrench, socket, torque wrench

Bolt (1): Width across flats 19 mm, M12

 Bolt (1):  
98 to 123 Nm {10.0 to 12.5 kgfm}

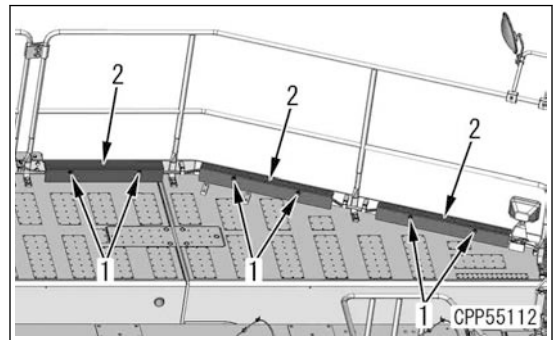
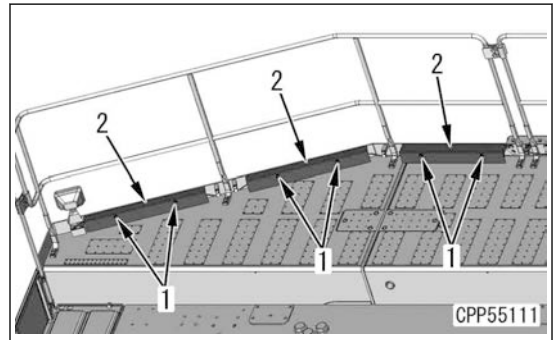

REMOVE AND INSTALL HYDRAULIC PUMP ASSEMBLY

64. By using the lifting tool (F), sling the No.1 main pump assembly (97), and hold it.



No.1 main pump assembly (97):

470 kg

65. Remove the bolts (98) (6 pieces).

Tool: Impact wrench, socket wrench

Bolt (98): Width across flats 36 mm, M24

66. Remove the No.1 main pump assembly (97) in the following procedure.

- 1) Move the pump to the fan side, and pull out the spline.
- 2) Rotate the main pump assembly by 90 °.
- 3) Sling the main pump assembly.

**REMARK**

Sling the No.1 main pump assembly (97) gradually, and remove it in order not to damage the hose.

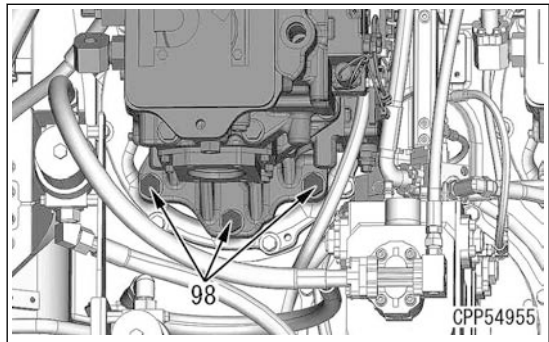
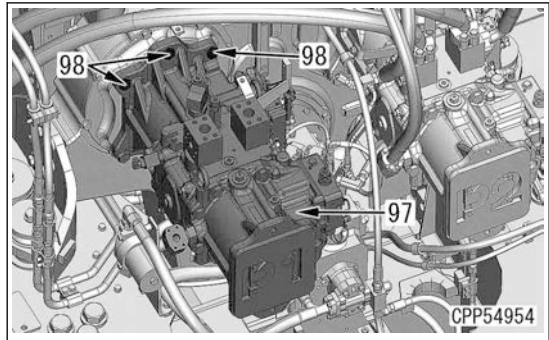

**No.2 main pump assembly**

67. Disconnect the connectors V14 (99) and P28B (100).

68. Disconnect the connectors V13 (101) and P28A (102).

69. Remove the clamps (103) (2 pieces).

Tool: Impact wrench, socket wrench

Bolt for clamp (103): Width across flats 17 mm, M10

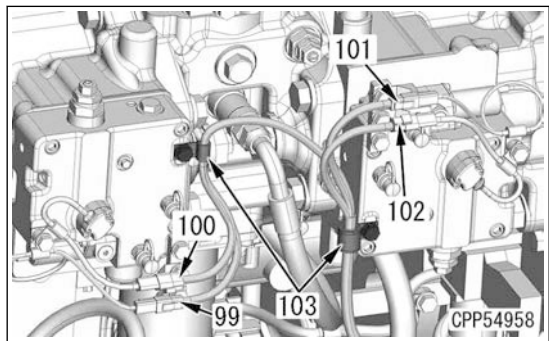

70. Remove the flange (104), and disconnect the hose (105).

Tool: Impact wrench, socket wrench

Bolt for flange (104): Width across flats 19 mm, M12

71. Remove the flange (106), and disconnect the hose (107).

Tool: Impact wrench, socket wrench

Bolt for flange (106): Width across flats 19 mm, M12

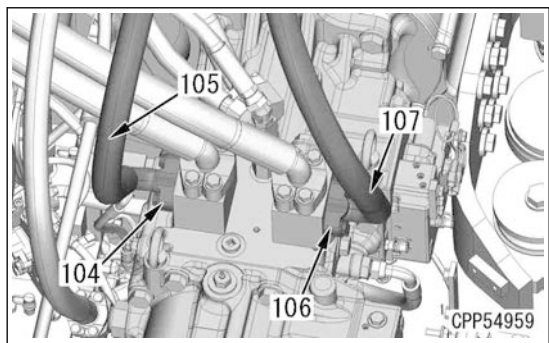

72. Remove the flange (108), and disconnect the hose (105).

Tool: Impact wrench, socket wrench

Bolt for flange (108): Width across flats 19 mm, M12

73. Remove the flange (109), and disconnect the hose (107).

Tool: Impact wrench, socket wrench

Bolt for flange (109): Width across flats 19 mm, M12

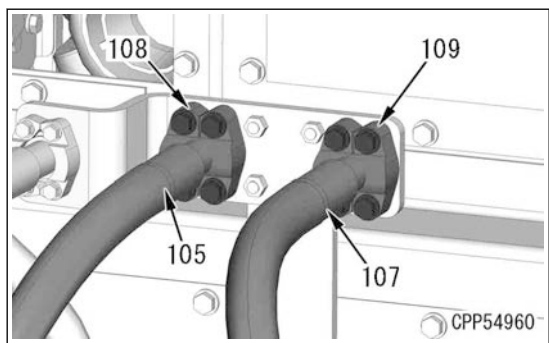

## METHOD FOR INSTALLING CONTROL VALVE ASSEMBLY

### Main valve (L)

1. Sling the main valve (L) (222), and set it to the mounting position.

Tool: Lifting tool



Main valve (L) (222):

830 kg

2. Install the bolts (224) (4 pieces).

Tool: Ratchet handle, socket wrench, torque wrench

Bolt (224): Width across flats 24 mm, M16



Bolt (224):

235 to 285 Nm {23.5 to 29.5 kgfm}

3. Install the bolts (223) (4 pieces), and install the main valve (L) (222).

Tool: Ratchet handle, socket wrench, torque wrench

Bolt (223): Width across flats 24 mm, M16



Bolt (223):

235 to 285 Nm {23.5 to 29.5 kgfm}

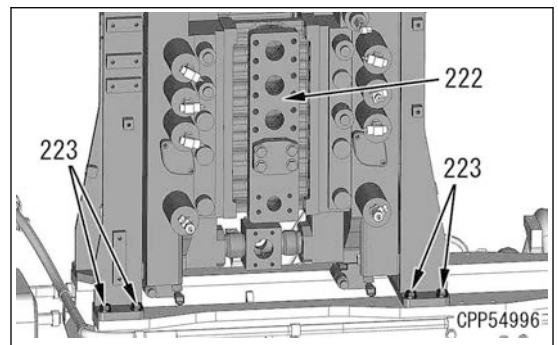
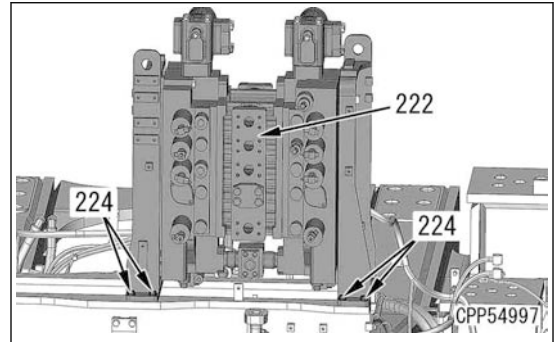

### Main valve (R)

4. Sling the main valve (R) (219), and set it to the mounting position.

Tool: Lifting tool



Main valve (R) (219):

830 kg

5. Install the bolts (221) (4 pieces).

Tool: Ratchet handle, socket wrench, torque wrench

Bolt (221): Width across flats 24 mm, M16



Bolt (221):

235 to 285 Nm {23.5 to 29.5 kgfm}

6. Install the bolts (220) (4 pieces), and install the main valve (R) (219).

Tool: Ratchet handle, socket wrench, torque wrench

Bolt (220): Width across flats 24 mm, M16



Bolt (220):

235 to 285 Nm {23.5 to 29.5 kgfm}

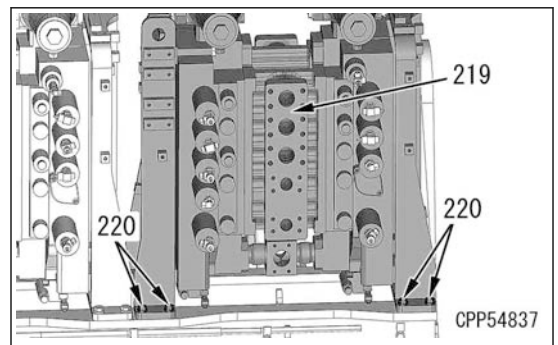
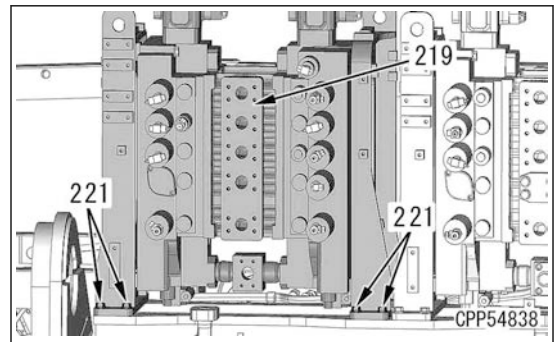

## METHOD FOR INSTALLING BUCKET CYLINDER ASSEMBLY

### Bucket cylinder assembly

1. Sling the bucket cylinder assembly (14) with the lifting tool (F), and set it to the mounting position.

#### NOTICE

- Never insert your fingers into the pin holes when aligning the holes.
- Expand the arm, and set the block (D) between the cylinder and arm.

 Bucket cylinder assembly (14):

900 kg

2. Sling the pin on the bottom side (17) with the lifting tool, and install it.

 Pin on the bottom side (17):

40 kg

 Inside of the bushing when assembling the pin:  
Anti-friction compound (LM-P)

 Greasing after assembling the pin:  
Grease (LM-G)

3. Install the plate (16) with the bolts (15) (2 pieces).  
Tool: Ratchet handle, socket wrench, torque wrench  
Bolt (15): Width across flats 36 mm, M24

 Bolt (15):  
785 to 980 Nm {80 to 100 kgfm}

4. Connect the greasing hose (13) with the sleeve nut.  
Tool: Wrench, torque wrench

Greasing hose (13): Width across flats 10 mm

 Greasing hose (13):  
11.0 to 14.0 Nm {1.1 to 1.4 kgfm}

5. Connect the hose (12) with the flange (11).  
Tool: Ratchet handle, socket wrench, torque wrench  
Bolt for flange (11): Width across flats 27 mm, M18

 Bolt for flange (11):  
320 to 400 Nm {33 to 41 kgfm}

6. Connect the hose (10) with the flange (9).  
Tool: Ratchet handle, socket wrench, torque wrench  
Bolt for flange (9): Width across flats 22 mm, M14

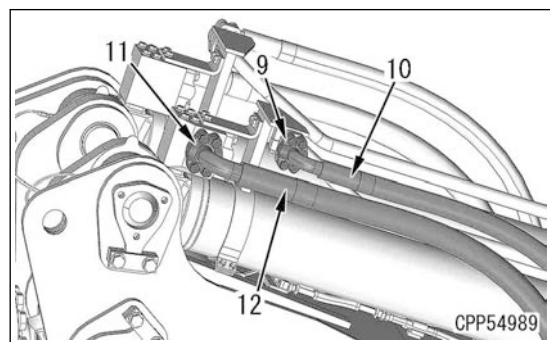
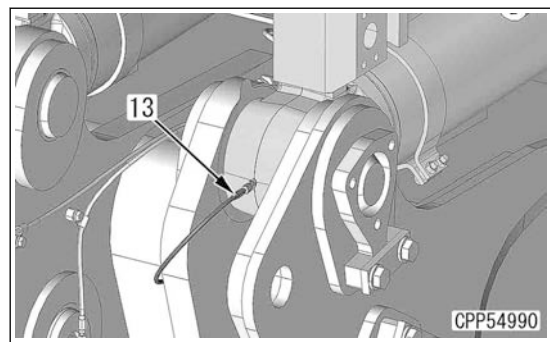
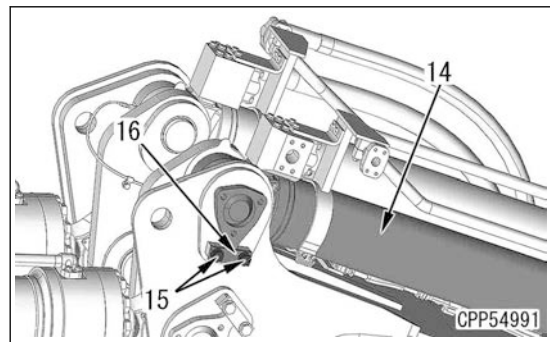
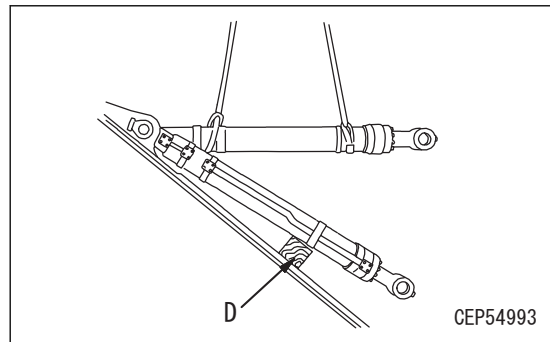
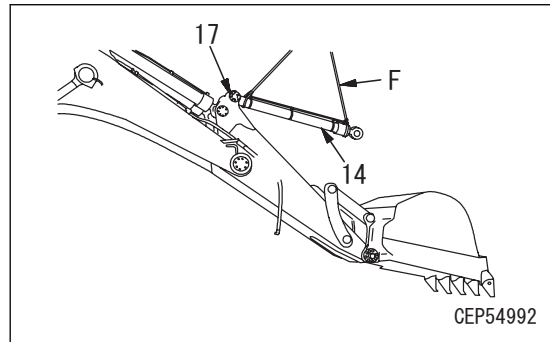

**Cap**

10. Pull out the cap (8) while screwing in the screws, etc. by using the pliers.

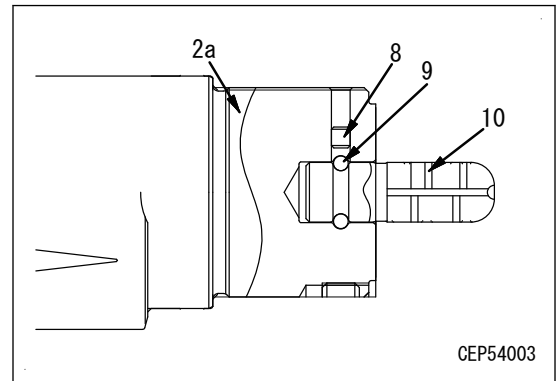

**Plunger (Only for the arm cylinder and bucket cylinder)**

11. Pull out the ball (9), and remove the plunger (10).  
 Ball (9) of the arm cylinder: 10 pieces  
 Ball (9) of the bucket cylinder: 11 pieces

**Disassembling the piston assembly**

12. Remove the ring (11).
13. Remove the wear ring (12).  
 Boom cylinder: 2 pieces  
 Bucket, arm cylinder: 4 pieces
14. Remove the piston ring (13).
15. Remove O-ring and backup ring (14).

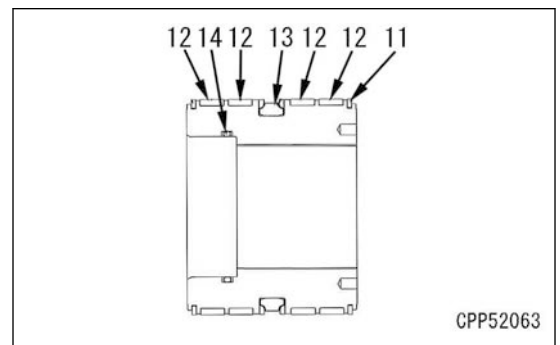
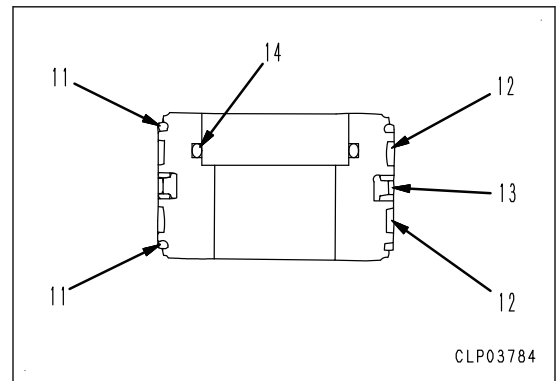

**Disassembling the cylinder head assembly**

16. Remove O-ring and backup ring (15).
17. Remove the snap ring (16), and remove the dust seal (17).
18. Remove the rod packing (18).
19. Remove the buffer ring (19).
20. Remove the snap ring (20).
21. Remove the bushing (21).

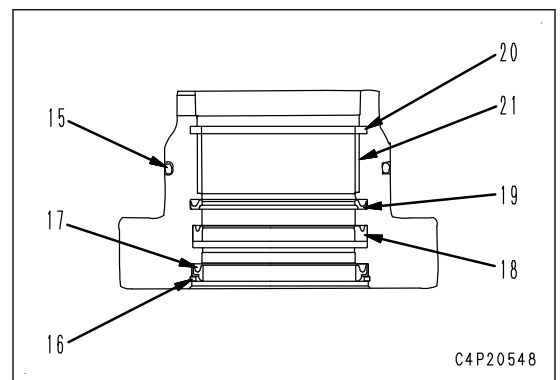

## REMOVE AND INSTALL OPERATOR'S CAB GLASS (ASSEMBLING TYPE)

Tools to be used when removing and installing the operator's cab glass (assembly type)

Symbol	Part No.	Part name	Necessity	Q'ty	New/Redesign	Sketch	Remarks
A	Commercially available	Needle-nose plier	•	1			Removing the operator's cab glass (assembly type)

- ⚠ Place the machine on a level ground, lower the work equipment completely to the ground in a stable posture, and set the work equipment lock lever to LOCK position.
- ⚠ Stop the engine, turn the battery isolator switch to OFF position, and remove the key. (For details, see TESTING AND ADJUSTING, "HANDLE BATTERY ISOLATOR AND STARTING MOTOR ISOLATOR".)

### METHOD FOR REMOVING OPERATOR'S CAB GLASS (ASSEMBLING TYPE)

Operator's cab glass (assembly type)

**REMARK**

This section explains removing and installing of the operator's cab glasses (assembly type) (1), (2), and (6).

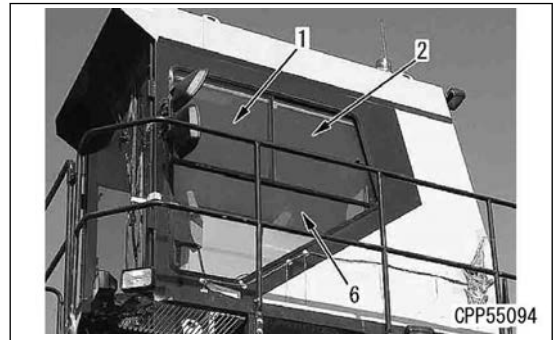

1. Remove the glasses (1) and (2) according to the following procedure.
  - 1) Lift the glasses (1) and (2) upward.
  - 2) Separate the glasses (1) and (2) from the lower frame (F), and tilt them sideways to remove them.

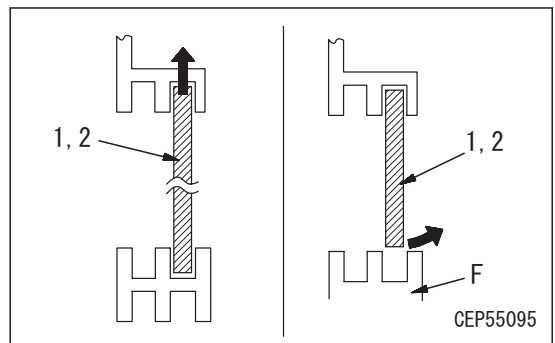

2. Remove the hexagonal socket head bolts (3) (9 pieces), and remove the cover (4).
 

Tool: Hexagonal wrench

Hexagonal socket head bolt (3): Width across flats 5 mm, M8

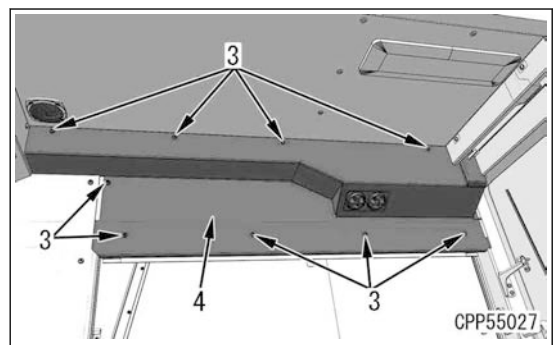

4. Remove the cap (5).

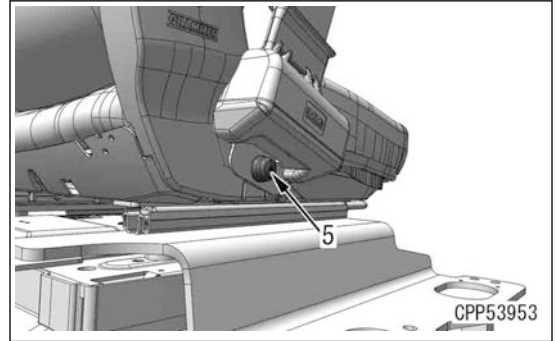

5. Remove the bolt (6), and remove the seat belt (7) on the reel side.

Tool: Impact wrench, socket wrench

Bolt (6): Width across flats 15.9 mm(5/8 in), nominal U7/16

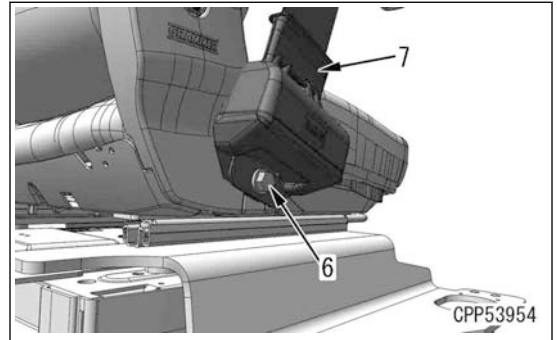

## METHOD FOR INSTALLING SEAT BELT

### Seat belt

1. Install the seat belt (7) on the reel side with the bolt (6).

Tool: Ratchet handle, socket wrench, torque wrench

Bolt (6): Width across flats 15.9 mm(5/8 in), nominal U7/16

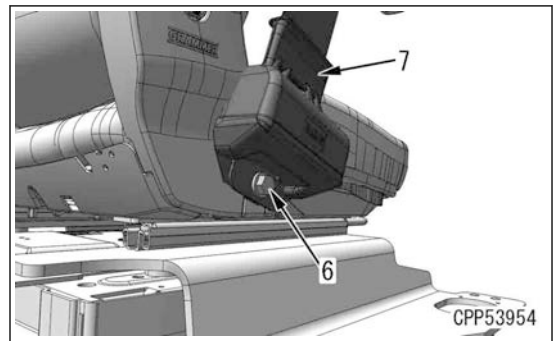

2. Install the cap (5).

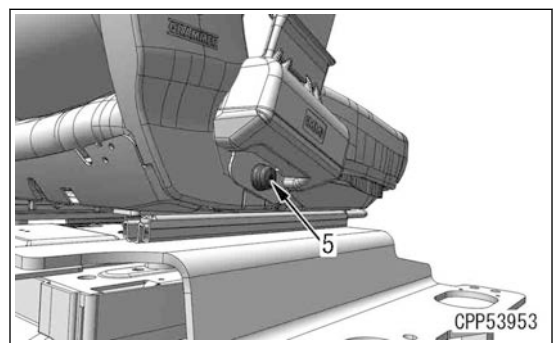

## REMOVE AND INSTALL KDPF TEMPERATURE SENSOR

3. Disconnect connector DPFT (5).

**REMARK**

Slide the yellow lever in the direction of the arrow, release the lock, and disconnect it.

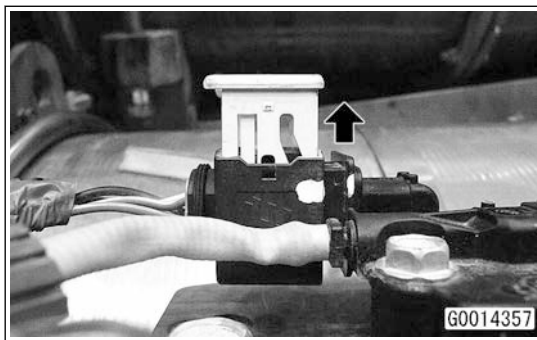
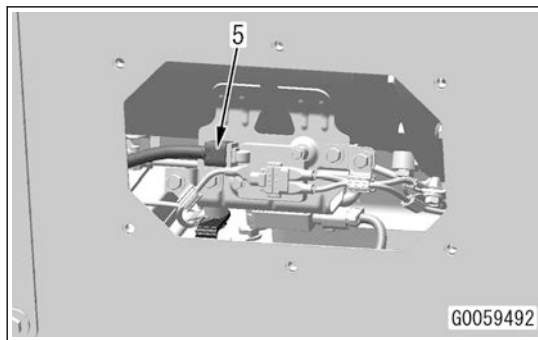

4. Remove clamps (6) (2 pieces).

**REMARK**

- Clamps (6) (2 pieces) are tightened together.
- Remove it while holding nut.

Tool: Impact wrench, socket

Bolt for clamp (6): Width across flats 14 mm, M10

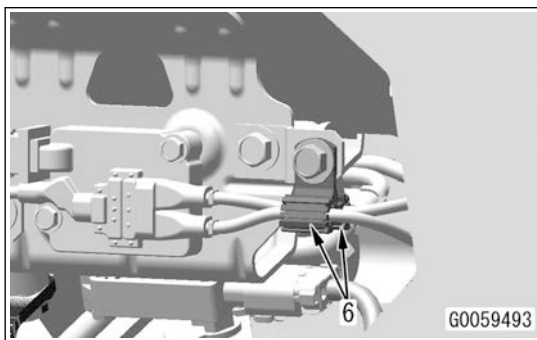

5. Remove clamps (7) (2 pieces).

**REMARK**

- Clamps (7) (2 pieces) are tightened together.
- Remove it while holding nut.

Tool: Impact wrench, socket

Bolt for clamp (7): Width across flats 14 mm, M10

6. Remove clamps (8) (2 pieces).

**REMARK**

- Clamps (8) (2 pieces) are tightened together.
- Remove it while holding nut.

Tool: Impact wrench, socket

Bolt for clamp (8): Width across flats 14 mm, M10

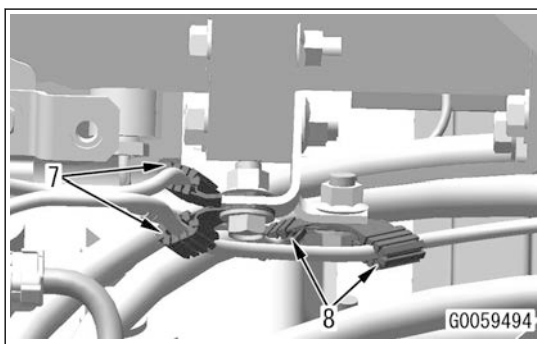

## ABBREVIATION LIST

- This list of abbreviations includes the abbreviations used in the text of the shop manual for parts, components, and functions whose meaning is not immediately clear. The spelling is given in full with an outline of the meaning.
- Abbreviations that are used in general society may not be included.
- Special abbreviations which appear infrequently are noted in the text.
- This list of abbreviations consists of two parts. The first part is a list of the abbreviations used in the text of the manual, and the second part is a list of the abbreviations used in the circuit diagrams.

### List of abbreviations used in the text

Abbreviation	Actual word spelled out	Purpose of use (major applicable machine (*1), or component/system)	Explanation
ABS	Antilock Brake System	Travel and brake (HD, HM)	This is a function that releases the brake when the tires skid (tires are not rotated). This function applies the brake again when the tires rotate.
AISS	Automatic Idling Setting System	Engine	This is a function that automatically sets the idle speed.
AJSS	Advanced Joystick Steering System	Steering (WA)	This is a function that performs the steering operations with a lever instead of using a steering wheel. This function performs gear shifting and changing forward and reverse direction.
ARAC	Automatic Retarder Accelerator Control	Travel and brake (HD, HM)	This is a function that automatically operates the retarder with a constant braking force when letting go of the accelerator pedal on the downhill.
ARSC	Automatic Retarder Speed Control	Travel and brake (HD, HM)	This is a function that automatically operates the retarder to ensure that the machine speed does not accelerate above the speed set by the operator when letting go of the accelerator pedal on the downhill.
ASR	Automatic Spin Regulator	Travel and brake (HD, HM)	This is a function that drives both wheels automatically using the optimum braking force when the tire on one side spins on the soft ground surfaces.
ATT	Attachment	Work equipment	A function or component that can be added to the standard specification.
BCV	Brake cooling oil control valve	BRAKE (HD)	This is a valve that bypasses a part of the brake cooling oil to reduce the load applied to the hydraulic pump when the retarder is not being used.
CAN	Controller Area Network	Communication and electronic control	This is one of communication standards that are used in the network on the machine.
CDR	Crankcase Depression Regulator	Engine	This is a regulator valve that is installed to KCCV ventilator. It is written as CDR valve and is not used independently.
CLSS	Closed-center Load Sensing System	Hydraulic system	This is a system that can actuate multiple actuators simultaneously regardless of the load (provides better combined operation than OLSS).

No.	Item	Judgment criteria	Remedy
1	Tightening torque of the bolt	181 to 240 Nm {18.5 to 24.5 kgfm}	Re-tighten
2	Tightening torque of the bolt	7.8 to 9.8 Nm {0.8 to 1 kgfm}	
3	Tightening torque of plug	127 to 176 Nm {13 to 18 kgfm}	
4	Tightening torque of plug	127 to 176 Nm {13 to 18 kgfm}	
5	Tightening torque of the nut	539 to 647 Nm {55 to 66 kgfm}	
6	Tightening torque of the nut	539 to 647 Nm {55 to 66 kgfm}	
7	Tightening torque of the nut	539 to 647 Nm {55 to 66 kgfm}	
8	Tightening torque of the bolt	152 to 160 Nm {15.5 to 16.4 kgfm}	
9	Tightening torque of plug	181 to 240 Nm {18.5 to 24.5 kgfm}	
10	Tightening torque of solenoid valve	127.4 to 176.4 Nm {13 to 18 kgfm}	
11	Tightening torque of plug	34.3 to 44.1 Nm {3.5 to 4.5 kgfm}	

Sectional views (A-A, B-B)

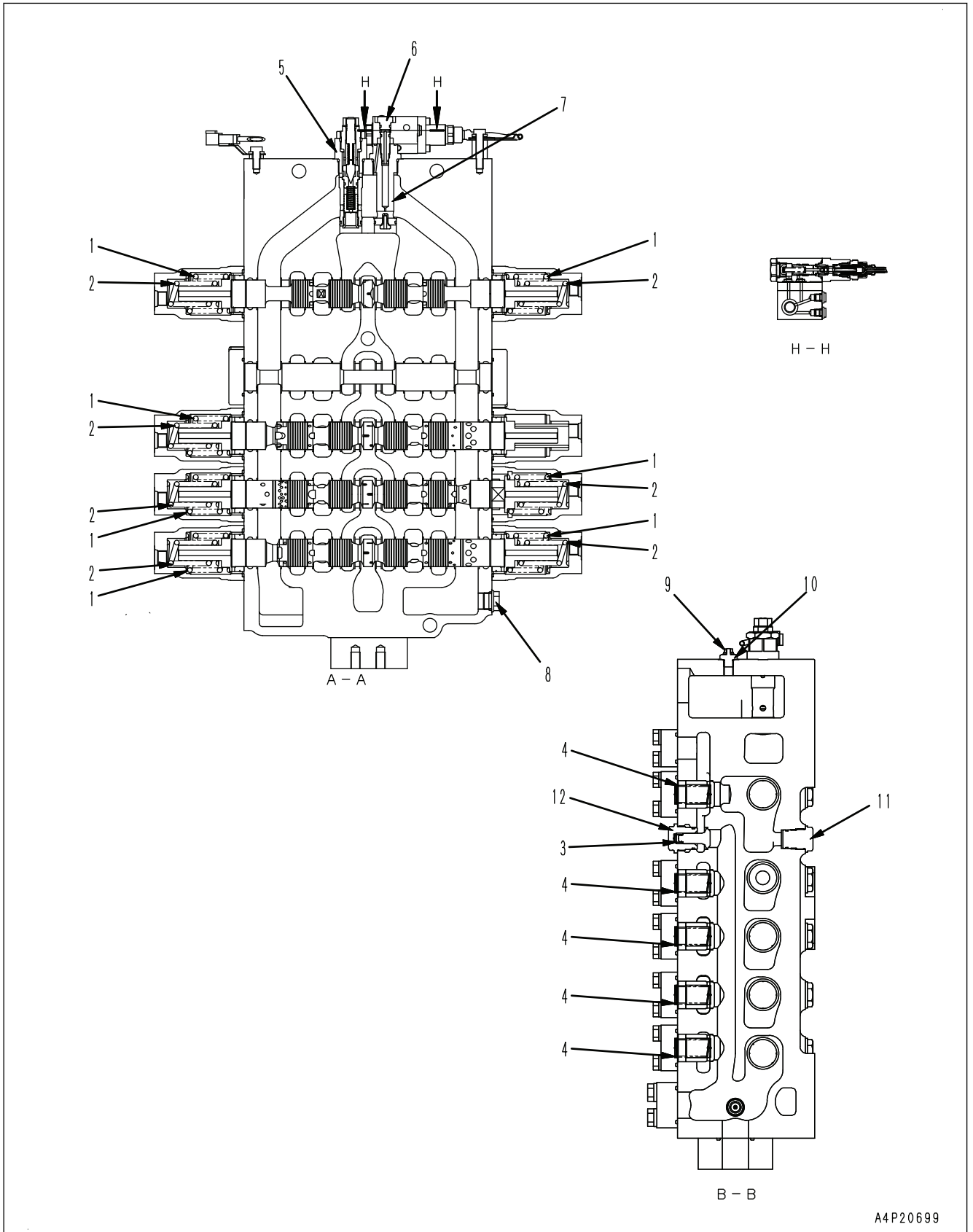

A4P20699

# CONTENTS

- ABBREVIATION LIST ..... 80-5
- AIR CONDITIONER SYSTEM ..... 80-11
  - PRECAUTIONS FOR REFRIGERANT ..... 80-11
  - AIR CONDITIONER COMPONENT ..... 80-12
  - AIR CONDITIONER COMPONENT ..... 80-14
  - SPECIFICATIONS OF AIR CONDITIONER ..... 80-16
  - CONFIGURATION AND FUNCTION OF REFRIGERATION CYCLE ..... 80-17
  - OUTLINE OF REFRIGERATION CYCLE ..... 80-18
- COMPONENT PARTS OF AIR CONDITIONER SYSTEM ..... 80-20
  - AIR CONDITIONER UNIT ..... 80-20
    - CONFIGURATION DIAGRAM OF AIR CONDITIONER UNIT ..... 80-20
    - FUNCTION OF AIR CONDITIONER UNIT ..... 80-22
    - FUNCTION OF EVAPORATOR AS AIR CONDITIONER UNIT COMPONENT ..... 80-23
    - FUNCTION OF HEATER CORE AS AIR CONDITIONER UNIT COMPONENT ..... 80-24
    - FUNCTION OF EVAPORATOR TEMPERATURE SENSOR AS AIR CONDITIONER UNIT COMPONENT ..... 80-24
    - FUNCTION OF SERVO MOTOR AS AIR CONDITIONER UNIT COMPONENT ..... 80-24
    - STRUCTURE OF EXPANSION VALVE AS AIR CONDITIONER UNIT COMPONENT ..... 80-25
    - FUNCTION OF EXPANSION VALVE AS AIR CONDITIONER UNIT COMPONENT ..... 80-25
    - OPERATE EXPANSION VALVE AS AIR CONDITIONER UNIT COMPONENT ..... 80-25
    - FUNCTION OF DUAL PRESSURE SWITCH ..... 80-26
  - AIR CONDITIONER CONTROLLER ..... 80-27
    - STRUCTURE OF AIR CONDITIONER CONTROLLER ..... 80-27
  - COMPRESSOR ..... 80-28
    - STRUCTURE OF COMPRESSOR ..... 80-28
    - SPECIFICATIONS OF COMPRESSOR ..... 80-28
    - FUNCTION OF COMPRESSOR ..... 80-28
  - CONDENSER ..... 80-29
    - STRUCTURE OF CONDENSER ..... 80-29
    - SPECIFICATIONS OF CONDENSER ..... 80-29
    - FUNCTION OF CONDENSER ..... 80-29
  - RECEIVER DRIER ..... 80-30
    - STRUCTURE OF RECEIVER DRIER ..... 80-30
    - SPECIFICATIONS OF RECEIVER DRIER ..... 80-30
    - FUNCTION OF RECEIVER DRIER ..... 80-30
  - SENSORS FOR AIR CONDITIONER SYSTEM ..... 80-31
    - FUNCTION OF SUNLIGHT SENSOR ..... 80-31
    - STRUCTURE OF AMBIENT TEMPERATURE SENSOR ..... 80-31
    - FUNCTION OF AMBIENT TEMPERATURE SENSOR ..... 80-31
- EXPLANATION OF PROCEDURE FOR TESTING AND TROUBLESHOOTING OF AIR CONDITIONER... 80-32
- CIRCUIT DIAGRAM AND ARRANGEMENT OF CONNECTOR PINS FOR AIR CONDITIONER ..... 80-34
- AIR CONDITIONER SYSTEM DIAGRAM ..... 80-36
  - AIR CONDITIONER CONTROL PANEL ..... 80-37
    - EXPLANATION OF AIR CONDITIONER EQUIPMENT ..... 80-37
  - INPUT AND OUTPUT SIGNALS OF AIR CONDITIONER CONTROLLER ..... 80-38
    - FUNCTION OF AIR CONDITIONER CONTROLLER ..... 80-39
- INSTALLATION LOCATIONS OF AIR CONDITIONER PARTS AND ARRANGEMENT OF CONNECTORS ..... 80-40
  - TESTING AIR LEAKAGE (DUCT) ..... 80-44
    - METHOD FOR TESTING AIR LEAKAGE (DUCT) ..... 80-44
  - TESTING AIR CONDITIONER USING SELF-DIAGNOSIS FUNCTION ..... 80-45
  - TEST VENT (MODE) CHANGEOVER ..... 80-47
    - METHOD FOR TESTING VENT (MODE) CHANGEOVER ..... 80-47
  - TESTING FRESH/RECIRC AIR CHANGEOVER ..... 80-51
    - METHOD FOR TESTING FRESH/RECIRC AIR CHANGEOVER ..... 80-51
  - TEST SUNLIGHT SENSOR ..... 80-52

Connector No.	Remarks	Location	Reference
[7] *1	Evaporator temperature sensor (frost sensor)	Air conditioner unit	Air conditioner unit and connectors layout

\*1: Connectors not used for troubleshooting.

### Fuses layout in fuse box F01

Open the cover of the fuse box behind the driver's seat.

No.10: Fuse for power supply to blower (fan) and air conditioner compressor (20 A)

No.14: Fuse for air conditioner unit, air conditioner controller and primary side power supply of electromagnetic clutch relay of air conditioner compressor (5 A)

No.19: Fuse for power supply (backup power supply) to air conditioner controller (5 A)

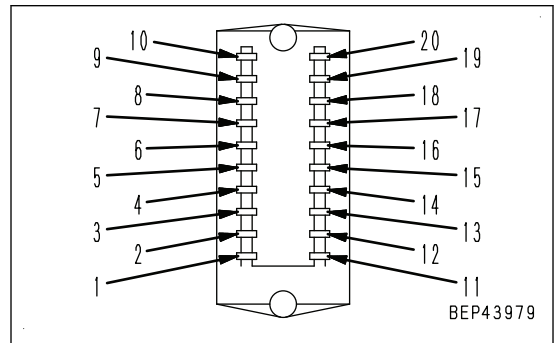
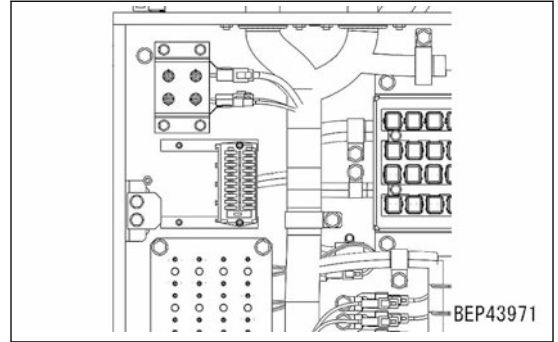

### Air conditioner unit and connectors layout

2: Power transistor connector [2]

3: FRESH/RECIRC air changeover servomotor connector [5]

4: Inside air temperature sensor connector [6]

5: Evaporator temperature sensor (frost sensor) connector [7]

#### REMARK

- Other than connector [2] on the rear side of the air conditioner unit, connectors cannot be disconnected while the unit is mounted on the machine.
- [2], [5], [6], and [7] are unlabeled connectors.

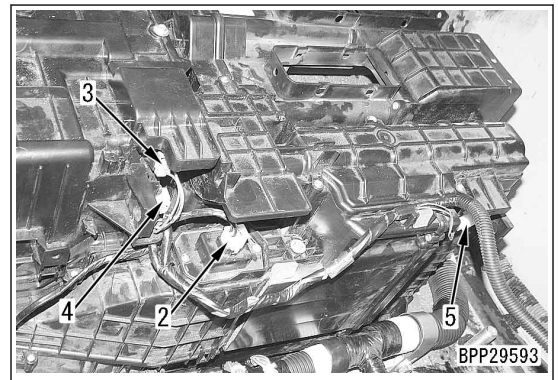

### Sunlight sensor connectors layout

1. Remove cover (1).

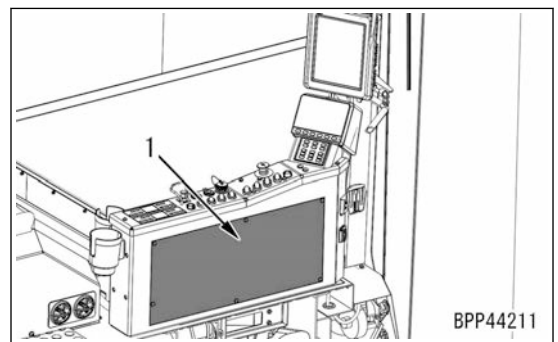

1. Select “Main Setting” (1) on the maintenance mode screen.

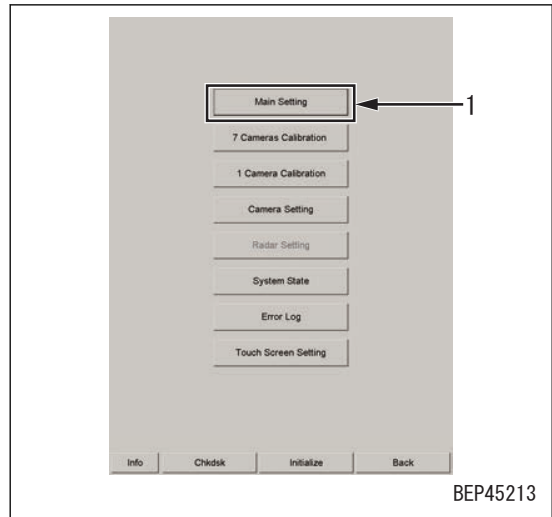

2. Set Machine Model (2) to “PC2000”.

When the machine model is set to “Machine Model”, “Body Front Options”, “Front End from Center”, “Rear End from Center”, “Swing Radius”, “Left End from Center”, “Right End from Center”, and “Limit Line(Middle)” are updated.

Check that the updated values are correct. If correction is required, see “Table of KomVision system default values” to correct setting values.

**REMARK**

Set Limit Line (Middle) according the customer's request.  
(Minimum value: SWING RADIUS+1500 mm)

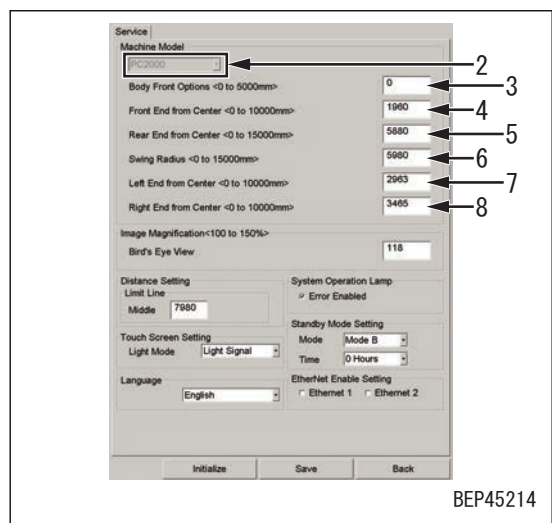
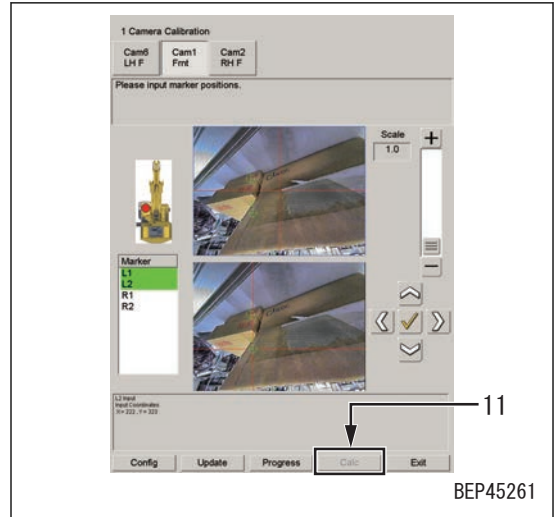

**Table of KomVision system default values**

No.	Setting item	Default value
3	Body Front Options <0 to 5000 mm>	0
4	Front End from Center <0 to 10000 mm>	1960
5	Rear End from Center <0 to 15000 mm>	5880
6	Swing Radius <0 to 15000 mm>	5980
7	Left End from Center <0 to 10000 mm>	2963
8	Right End from Center <0 to 10000 mm>	2465

3. Check the values in the monitor screen. If they are correct, press the “Save” button to save the values. Set items according to the procedure document for adjustment.

8. When specifying marker positions is completed for the camera to calibrate and the neighboring cameras on the right and left side, press the “Calc” button (11).



9. When the bird's eye view image taken from all the cameras is displayed on the “Result Bird's Eye View Dialog” screen (12), make sure that the grid lines on the calibration sheets are uniformly aligned, and that they are not greatly distorted.

10. Press the “CLOSE” button (13).  
The “Result Bird's Eye View Dialog” screen (12) is closed.

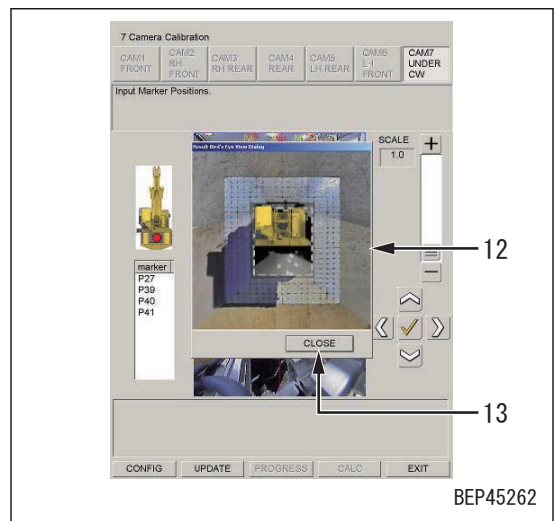

11. When the result display area (14) is displayed, perform the following operation.

- When “Calculation Completed Successfully.” is displayed: Proceed to step 12.
- When “Calculation completed, but large error - x.x Pixels.” is displayed: Specify the marker positions again starting at step 6.

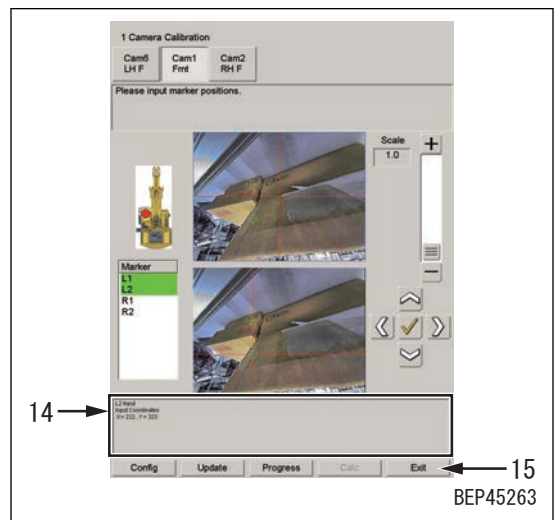

### Circuit diagram related to system operating lamp

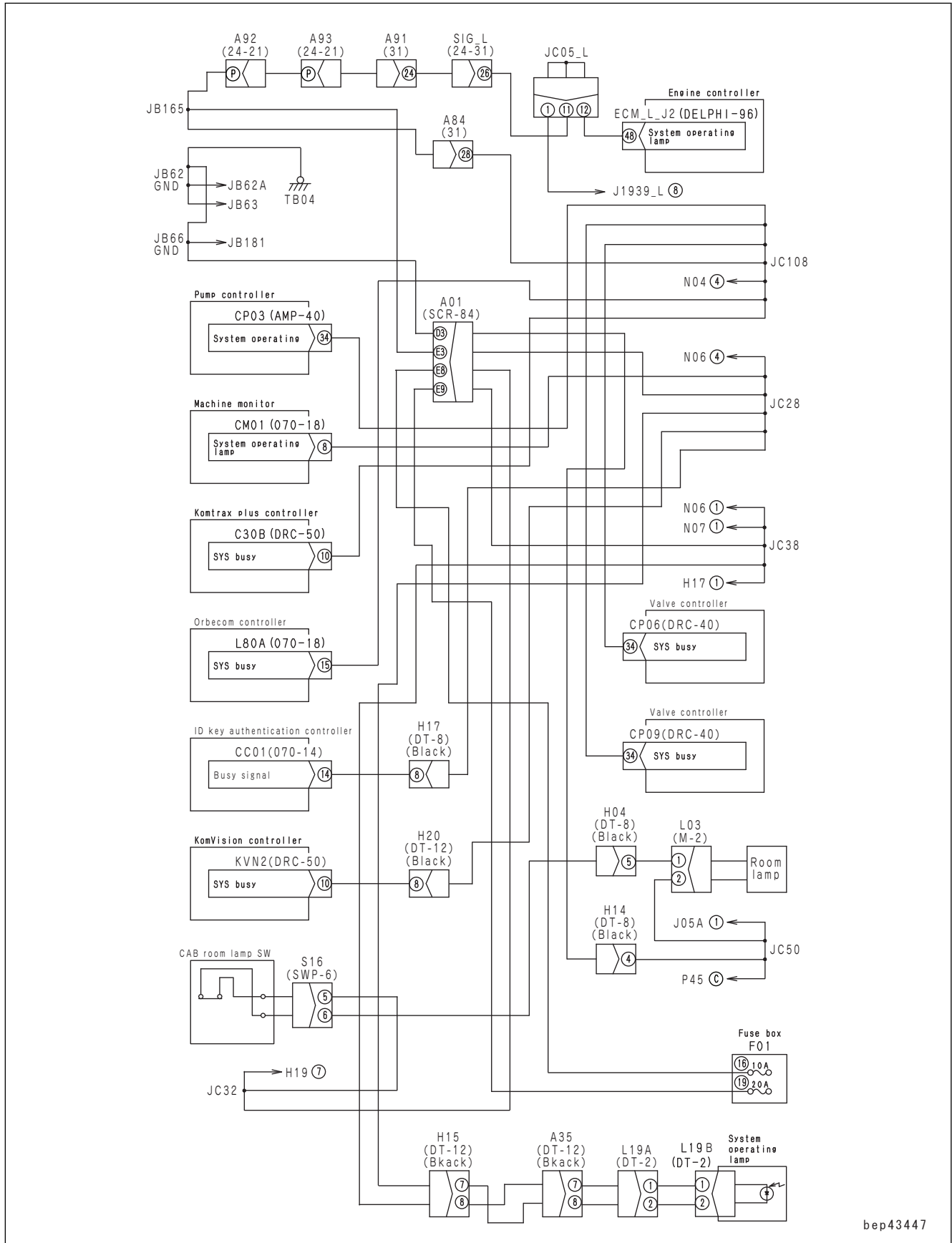

bep43447

Circuit diagram related to KomVision monitor night lighting switch

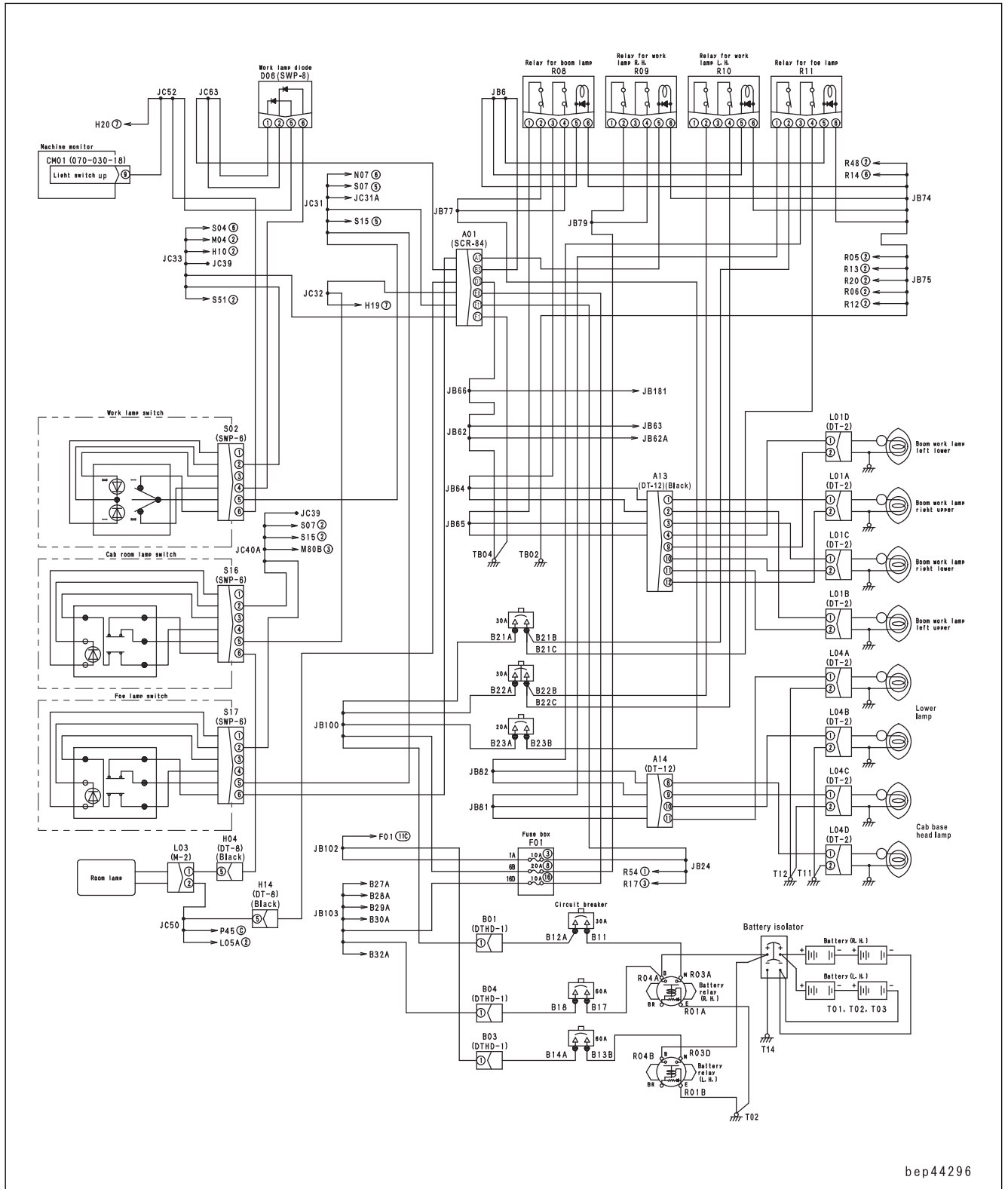

bep44296



CLICK HERE TO **DOWNLOAD** THE COMPLETE MANUAL

- Thank you very much for reading the preview of the manual.
- You can download the complete manual from: [www.heydownloads.com](http://www.heydownloads.com) by clicking the link below



- Please note: If there is no response to CLICKING the link, please download this PDF first and then click on it.

CLICK HERE TO **DOWNLOAD** THE COMPLETE MANUAL