

SHOP MANUAL



PC14R-3 PC14R-3HS
PC16R-3 PC16R-3HS

HYDRAULIC EXCAVATOR

SERIAL NUMBER

PC14R-3	F40003	and up
PC14R-3HS	F50003	and up
PC16R-3	F60003	and up
PC16R-3HS	F70003	and up

CLICK HERE TO **DOWNLOAD** THE COMPLETE MANUAL

- Thank you very much for reading the preview of the manual.
- You can download the complete manual from: www.heydownloads.com by clicking the link below



- Please note: If there is no response to CLICKING the link, please download this PDF first and then click on it.

CLICK HERE TO **DOWNLOAD** THE COMPLETE MANUAL

HOISTING INSTRUCTIONS

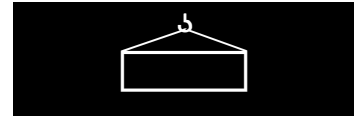

⚠ Heavy parts (25 kg or more) must be lifted with a hoist etc. In the Disassembly and Assembly section, every part weighing 25 kg or more is clearly indicated with the symbol 

- If a part cannot be smoothly removed from the machine by hoisting, the following checks should be made:
 - Check for removal of all bolts fastening the part to the relative parts.
 - Check for any part causing interference with the part to be removed.

2. Wire ropes

- Use adequate ropes depending on the weight of parts to be hoisted, referring to the table below:

WIRE ROPES (Standard «S» or «Z» twist ropes without galvanizing)	
Rope diameter (mm)	Allowable load (tons)
10.0	1.0
11.2	1.4
12.5	1.6
14.0	2.2
16.0	2.8
18.0	3.6
20.0	4.4
22.4	5.6
30.0	10.0
40.0	18.0
50.0	28.0
60.0	40.0

The allowable load value is estimated to be one-sixth or one-seventh of the breaking strength of the rope used.

- Sling wire ropes from the middle portion of the hook. Slings near the edge of the hook may cause the rope to slip off the hook during hoisting, and a serious accident can result.

Hooks have maximum strength at the middle portion.

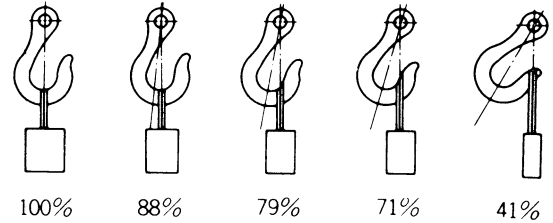

- Do not sling a heavy load with one rope alone, but sling with two or more ropes symmetrically wound on to the load.

⚠ Slings with one rope may cause turning of the load during hoisting, untwisting of the rope, or slipping of the rope from its original winding position on the load, which can cause dangerous accidents.

- Do not sling a heavy load with ropes forming a wide hanging angle from the hook.

When hoisting a load with two or more ropes, the force subjected to each rope will increase with the hanging angles.

The table below shows the variation of allowable load (kg) when hoisting is made with two ropes, each of which is allowed to sling up to 1000 kg vertically, at various hanging angles.

When two ropes sling a load vertically, up to 2000 kg of total weight can be suspended.

This weight becomes 1000 kg when two ropes make a 120° hanging angle.

On the other hand, two ropes are subjected to an excessive force as large as 4000 kg if they sling a 2000 kg load at a lifting angle of 150°.

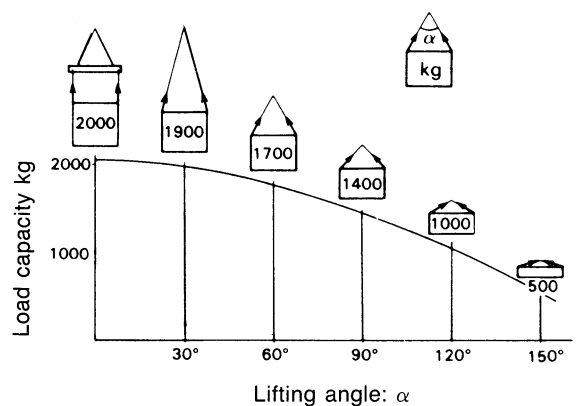

From liter to U.S. Gall.

1 ℓ = 0.2642 U.S. Gall.

	0	1	2	3	4	5	6	7	8	9
0	0	0.264	0.528	0.793	1.057	1.321	1.585	1.849	2.113	2.378
10	2.642	2.906	3.170	3.434	3.698	3.963	4.227	4.491	4.755	5.019
20	5.283	5.548	5.812	6.076	6.340	6.604	6.869	7.133	7.397	7.661
30	7.925	8.189	8.454	8.718	8.982	9.246	9.510	9.774	10.039	10.303
40	10.567	10.831	11.095	11.359	11.624	11.888	12.152	12.416	12.680	12.944
50	13.209	13.473	13.737	14.001	14.265	14.529	14.795	15.058	15.322	15.586
60	15.850	16.115	16.379	16.643	16.907	17.171	17.435	17.700	17.964	18.228
70	18.492	18.756	19.020	19.285	19.549	19.813	20.077	20.341	20.605	20.870
80	21.134	21.398	21.662	21.926	22.190	22.455	22.719	22.983	23.247	23.511
90	23.775	24.040	24.304	24.568	24.832	25.096	25.361	25.625	25.889	26.153

From liter to U.K. Gall.

1 ℓ = 0.21997 U.K. Gall.

	0	1	2	3	4	5	6	7	8	9
0	0	0.220	0.440	0.660	0.880	1.100	1.320	1.540	1.760	1.980
10	2.200	2.420	2.640	2.860	3.080	3.300	3.520	3.740	3.950	4.179
20	4.399	4.619	4.839	5.059	5.279	5.499	5.719	5.939	6.159	6.379
30	6.599	6.819	7.039	7.259	7.479	7.699	7.919	8.139	8.359	8.579
40	8.799	9.019	9.239	9.459	9.679	9.899	10.119	10.339	10.559	10.778
50	10.998	11.281	11.438	11.658	11.878	12.098	12.318	12.528	12.758	12.978
60	13.198	13.418	13.638	13.858	14.078	14.298	14.518	14.738	14.958	15.178
70	15.398	15.618	15.838	16.058	16.278	16.498	16.718	16.938	17.158	17.378
80	17.598	17.818	18.037	12.257	18.477	18.697	18.917	19.137	19.357	19.577
90	19.797	20.017	20.237	20.457	20.677	20.897	21.117	21.337	21.557	21.777

TRACK FRAME AND RECOIL SPRING

For steel shoe

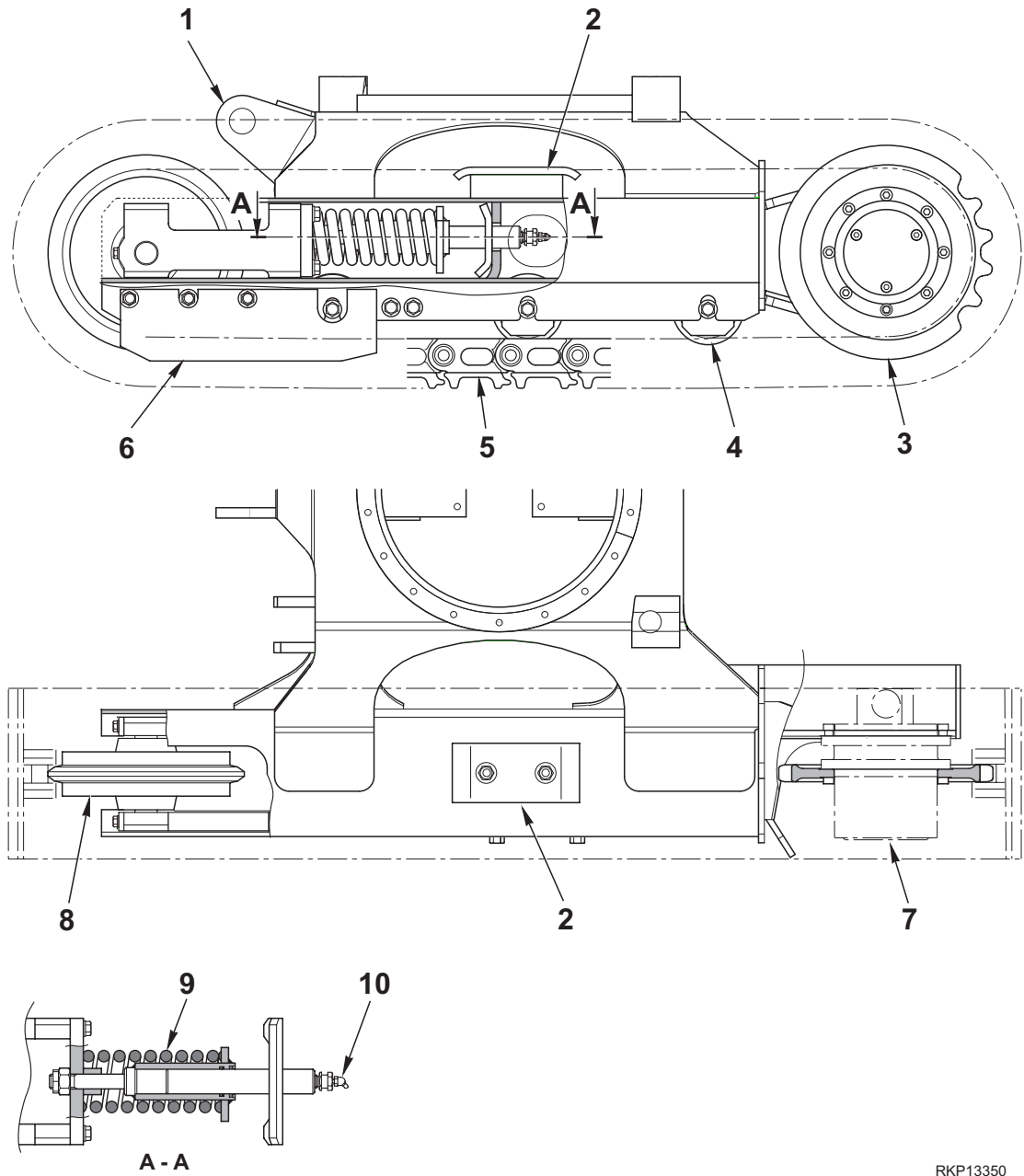

RKP13350

- | | |
|----------------|---------------------|
| 1. Track frame | 6. Guard |
| 2. Upper idler | 7. Final drive |
| 3. Sprocket | 8. Track shoe idler |
| 4. Lower idler | 9. Recoil spring |
| 5. Shoe | 10. Grease nipple |

Variable gauge version

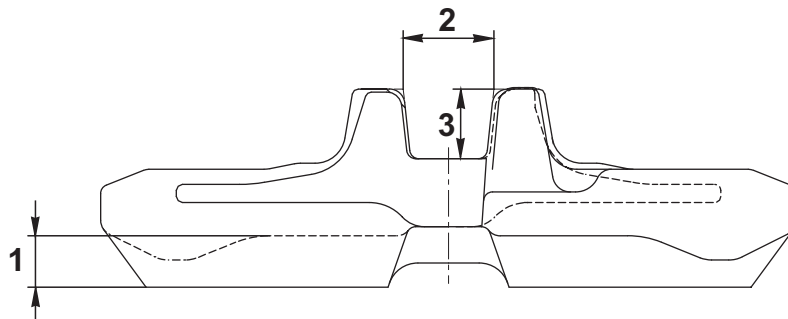
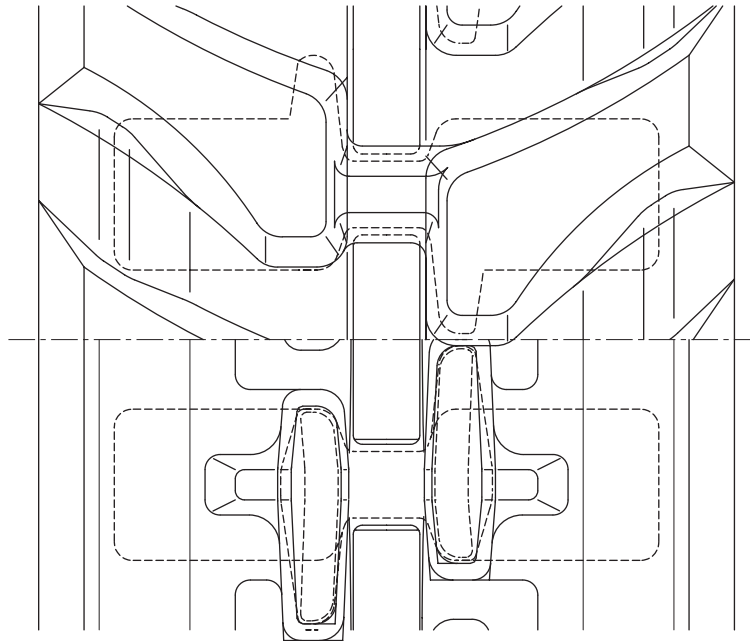

RKP13460

Unit: mm

N.	Check item	Value		Remedy
		Standard size	Repair limit	
1	Wear of lug height	25	5	Replace
		30	33	
2	Wear of roller guide	21	25	
3	Wear of meshing parts of sprocket			

PC14R-3 HS (variable gauge version)

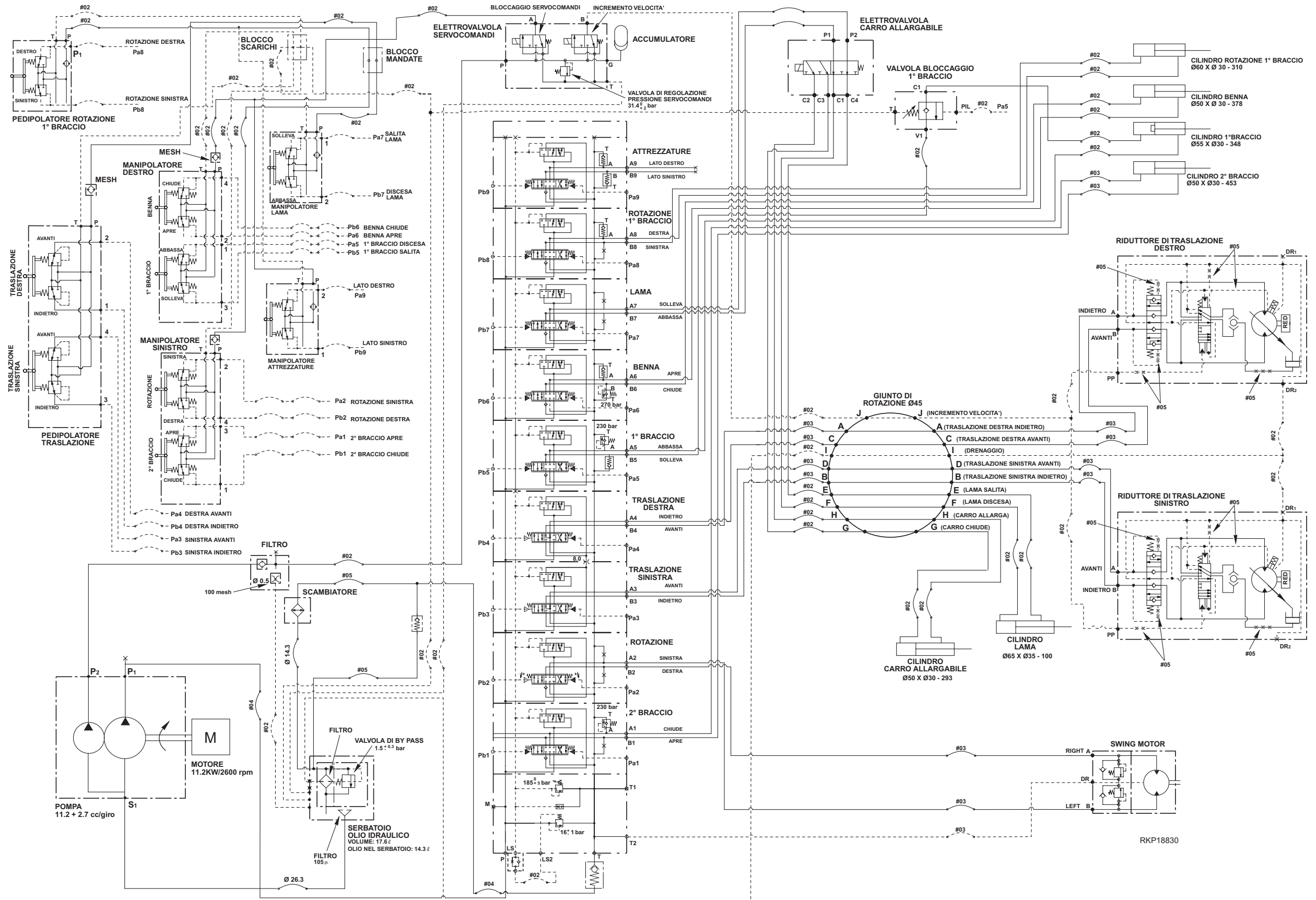

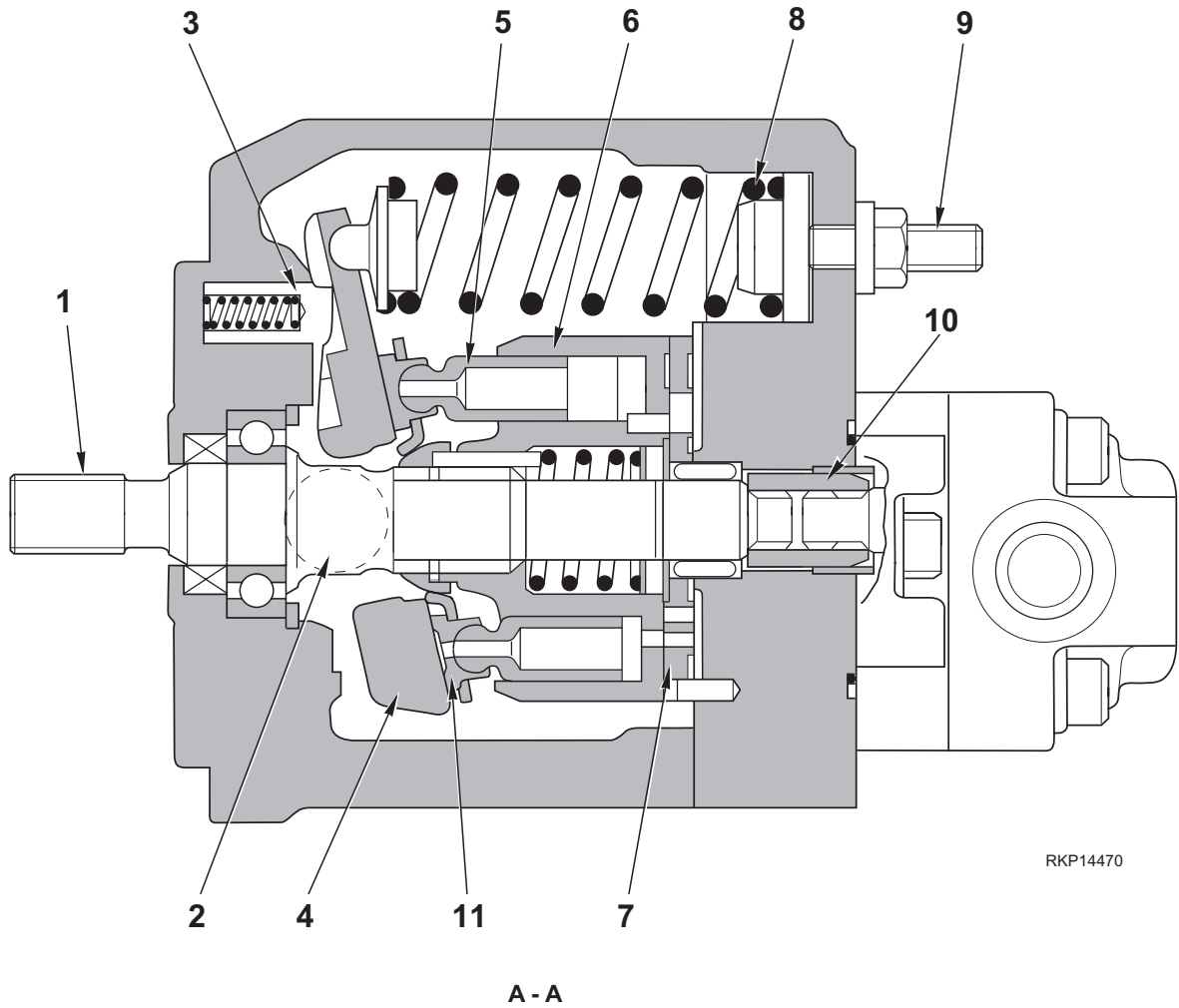

RKP14470

- 1. Shaft
- 2. Ball
- 3. Control piston
- 4. Swash plate
- 5. Piston
- 6. Cylinder block

- 7. Valve plate
- 8. Displacement adjustment spring
- 9. Adjustment screw
- 10. Joint
- 11. Shoe

BLADE PPC VALVE

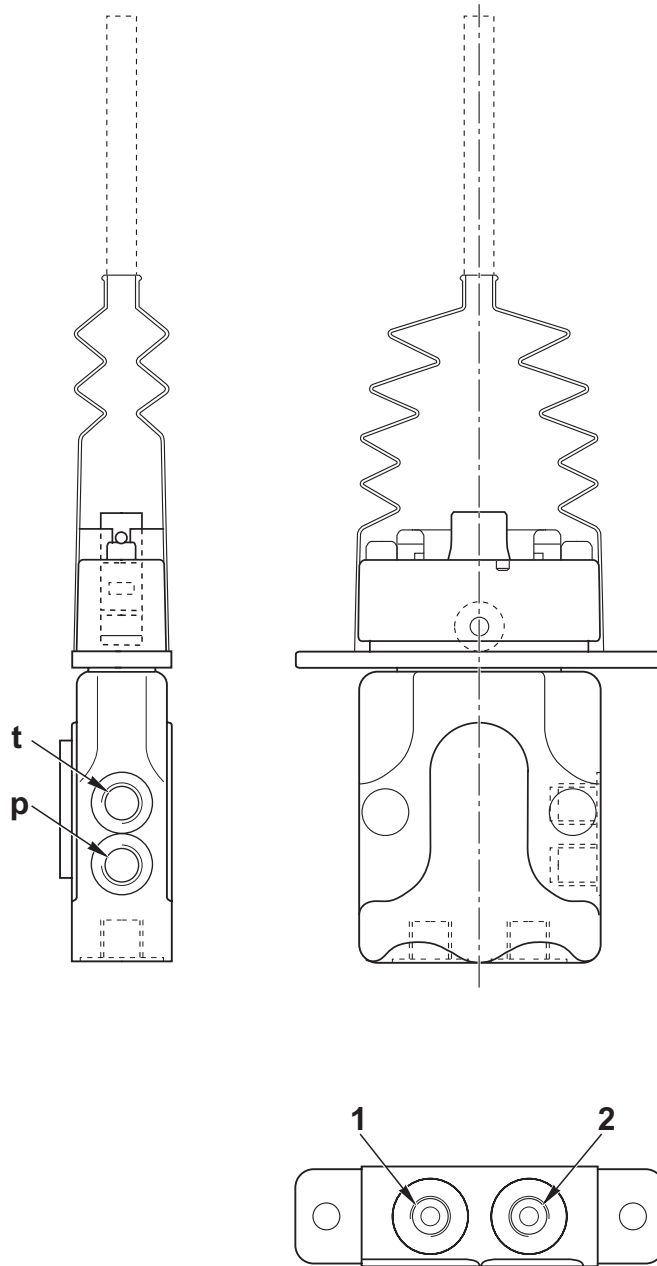

RKP18760

- T Port - To hydraulic tank
- P Port - From solenoid valve EV1 (A Port)
- 1 Port - To control valve (P Port) (Raise blade)
- 2 Port - To control valve (PB7 Port) (Lower blade)

Operation of 2nd motor

- Rocker cam (4) has 2 faces of **A** and **B** on the opposite side to the face on which shoe (6) slides. It is supported on 2 balls (7) fixed to body (8).
- Balls (7) are installed a little higher than the axis. Accordingly, in the 1st gear speed, face **A** is pressed against body (8) by the hydraulic force applied to piston (1) and the force of spring (9), and swash plate angle is set to **a** and the delivery of the motor is increased.

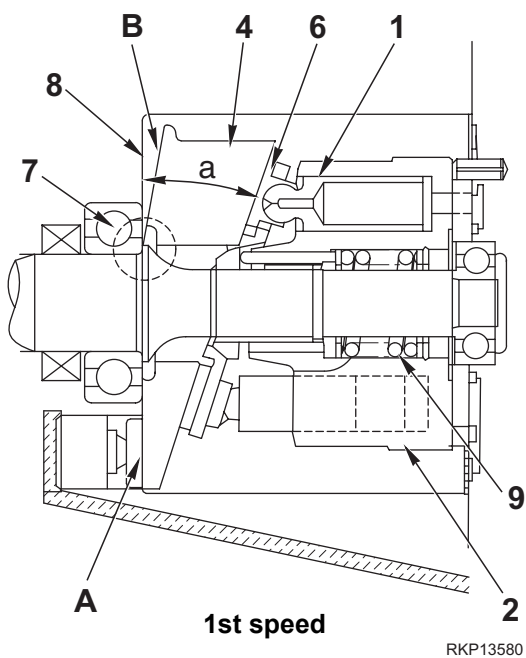

- If the 2nd gear lever is set, hydraulic oil **P** is led through the 2nd spool into control chamber (10).
- The control piston (11) moves to the right (→) until face **B** of rocker cam (4) contacts the travel motor body (8), and then rocker cam (4) is fixed at swash plate angle **b**. At this time, the delivery of the motor is reduced.

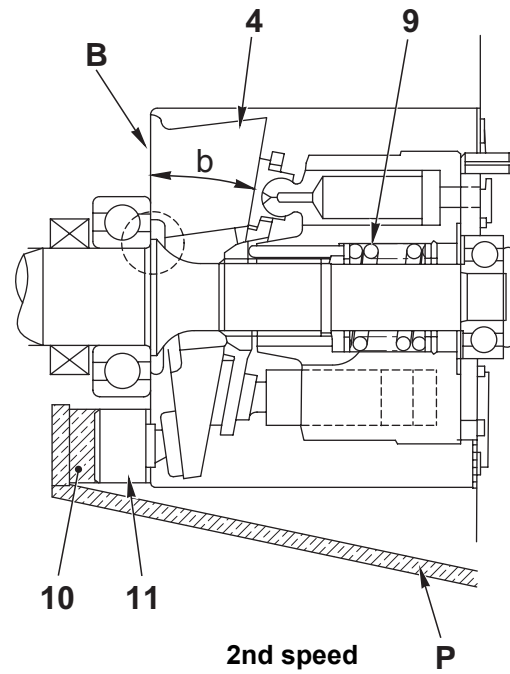

- While the engine is stopped, control chamber (10) is connected through the 2nd spool to the drain port.
- As a result, rocker cam (4) is returned to the 1st gear speed position by spring (9), thus the 1st gear speed is always selected when the machine starts travel.

20 CONTROLS AND ADJUSTMENTS

MACHINE SPECIFICATIONS AND COMPONENTS	3	CHECKING SERVO-CONTROL PRESSURE	37
PUMP FEATURES PC14R-3.....	10	CHECKING LS PRESSURE	39
PUMP FEATURES PC16R-3.....	11	ADJUSTING PPC VALVE CLEARANCE	41
CHECK POSITIONS.....	12	CHECKING FOR LEAKAGE INSIDE THE CYLINDERS.....	42
SPECIAL TOOLS.....	16	METHODS FOR TESTING FOR LEAKAGES INSIDE THE SWIVEL JOINT	45
TESTING ENGINE SPEED.....	17	ELIMINATING RESIDUAL PRESSURE FROM THE HYDRAULIC CIRCUITS.....	49
MEASUREMENT OF EXHAUST GAS COLOR.....	19	AIR BLEED.....	50
ADJUSTING VALVE CLEARANCE	21	CONTROL OF HYDRAULIC DRIFTS - ANALYSIS CAUSES OF A DRIFT	52
CHECKING COMPRESSION PRESSURE	23	HOW TO OPEN AND CLOSE (TILT) FLOOR (FOR CABIN)	58
CHECKING ENGINE OIL PRESSURE	24	HOW TO OPEN AND CLOSE (TILT) FLOOR (FOR CANOPY)	60
TESTING AND ADJUSTING FUEL INJECTION TIMING	25	ADJUSTING THE SERVO-CONTROL SAFETY MICROSWITCHES AND RUBBER PAD.....	62
ADJUSTING ENGINE STOP SOLENOID.....	27	KOMTRAX STATION OPENING CHECK (TC1310 station).....	63
BLEEDING AIR FROM FUEL CIRCUIT.....	28	KOMTRAX SYSTEM CHECKS.....	68
TESTING AND ADJUSTING FAN BELT TENSION	29		
ADJUSTING FUEL CONTROL LEVER LINKAGE.....	30		
MEASUREMENT OF CLEARANCE IN SWING CIRCLE BEARINGS.....	31		
TESTING AND ADJUSTING TRACK SHOE TENSION.....	32		
CONTROL AND REGULATION OF PRESSURE IN THE HYDRAULIC CIRCUITS.....	33		

PUMP FEATURES PC16R-3

PUMP "2"

Check item	Test Condition	Unit	Standard value for new machine	Service limit value
Discharge of gear pump	<ul style="list-style-type: none"> Oil temperature 45 – 55°C Engine speed: 2600 rpm Measure at set pressure of relief valve 	ℓ/min.	12.1	10.2

PISTON PUMP "1"

Check item	Test Condition	Check point	Flow rate at pressure (bar)	Standard discharge (ℓ/min)
Delivery piston pump	<ul style="list-style-type: none"> Oil temperature 45 – 55°C Engine speed: 2600 rpm ★ Inspect at points that are away from any variation in trend of curve. 	Each point	P	Q (See diagram)

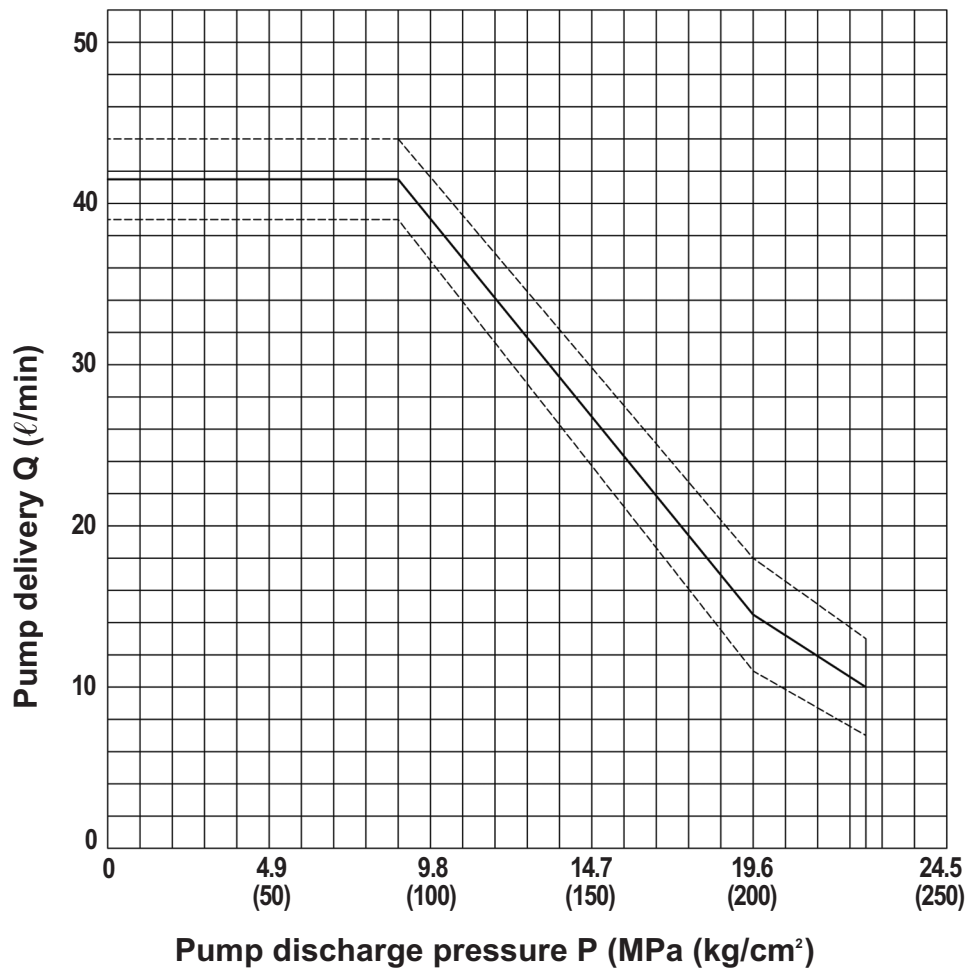

RKP14520



When measuring deliveries with the pumps mounted on the machine, it is difficult to use the accelerator to reach the precise number of revs needed for this test. Make delivery measurements with the engine running at about 2600 RPM and then make a proportional calculation to obtain the useful delivery check value.

ADJUSTING VALVE CLEARANCE

⚠ Carry out the valve clearance adjustment procedure on a cold engine.

⚠ Cylinder numbering begins on the fan side.

1 - Raise floor and engage lock pin. (For details, see "HOW TO OPEN AND CLOSE (TILT) FLOOR (FOR CABIN)").



2 - Remove the valve cover (1) and flywheel inspection plug.

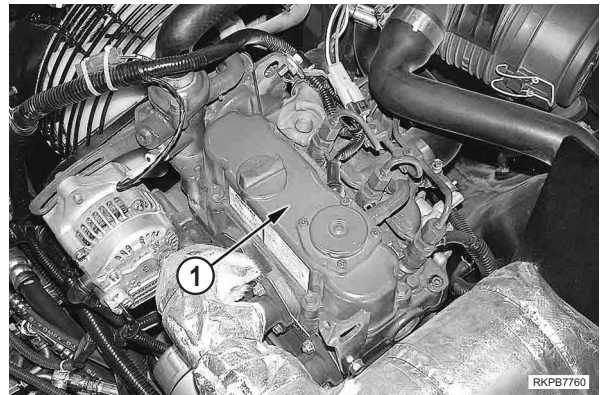

3 - Rotate the flywheel (2) in the normal direction of rotation to align the "1TC" index marking to the reference tab (3) that is visible in the inspection hole.

- ★ Ensure that cylinder No. 1 is in compression – i.e., there must be clearance between both rocker arms and the valves.
If this condition does not occur, rotate the driving shaft by one complete turn in the normal direction of operation and re-align the "1TC" index marking to the reference tab (3).

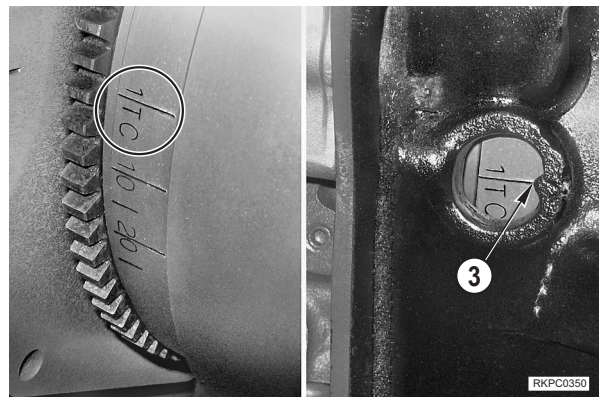

4 - While the No. 1 cylinder is at the compression top dead center, adjust the valve clearances marked with ● in the valve arrangement drawing according to the following procedure

	No. 1		No. 2		No. 3	
IN	EX	IN	EX	IN	EX	
●	●	○	●	●	○	

RKPC15160

MEASUREMENT OF CLEARANCE IN SWING CIRCLE BEARINGS

⚠ Be careful not to put a hand or foot under the undercarriage, while taking measurement.

1 - Fix dial gauge **G1** to the track frame and apply the probe to the underside of outer race perpendicularly.

★ Set dial gauge at the track frame rear.

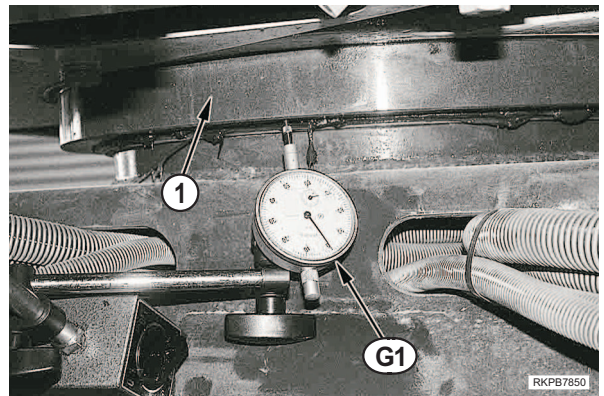

2 - Fully extend the equipment and lift the bucket teeth to reach the lower level of the revolving frame; rotate by 180°.

★ At this time, the front side of the upper structure rises and the front side lowers.

3 - Under this condition, set dial gauge **G1** to the zero point.

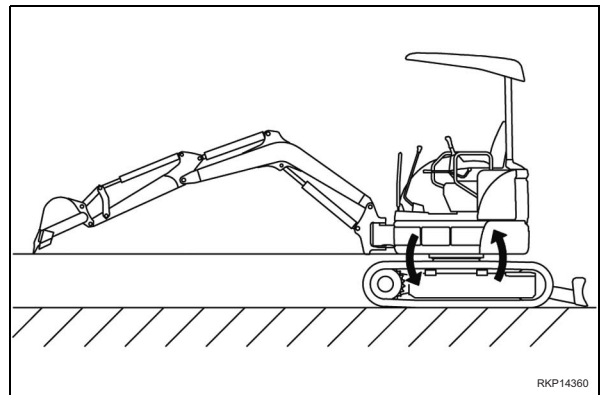

4 - Hold the arm nearly perpendicular to the ground, and lower the boom until the track shoes will be lifted at the work equipment.

★ The upper structure is raised at the front and lowered at the rear at that time.

5 - Read off the value in dial gauge **G1** in this condition.

★ The measured value is the clearance in swing circle bearing.

6 - Return the machine to the posture in Item 2 above, and confirm reading of dial gauge **G1** is zero.

★ If zero value is not indicated, repeat the steps in Items 3 through 5.

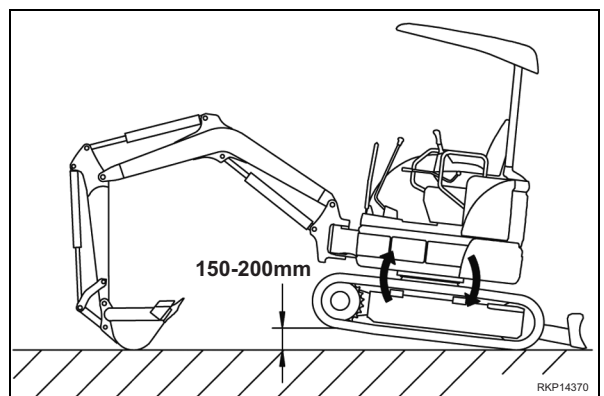

ADJUSTING PPC VALVE CLEARANCE

★ If the play of the left or right work equipment control lever is excessive, adjust it according to the following procedure.

- 1 -Remove the PPC valve (1) assembly.
- 2 -Loosen the nut (2) and remove the handle (3) and boot collar (4).

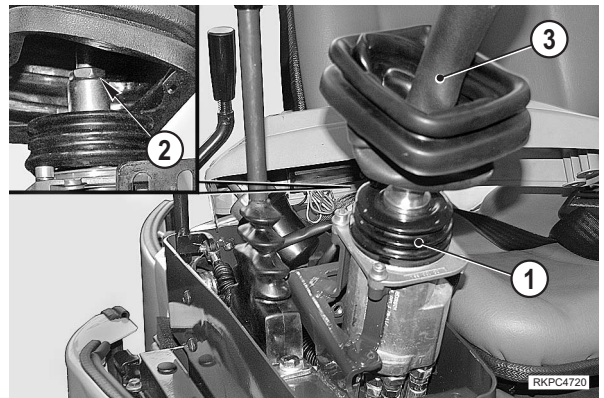

- 3 -Loosen and remove disc (5) and change spacer shim (6) until the disc rests on all heads of pistons (7).

 Handle: Loctite 262

 Handle nut: 40 Nm

★ Keep handle orientation unchanged while tightening.

 Disc: 50 Nm

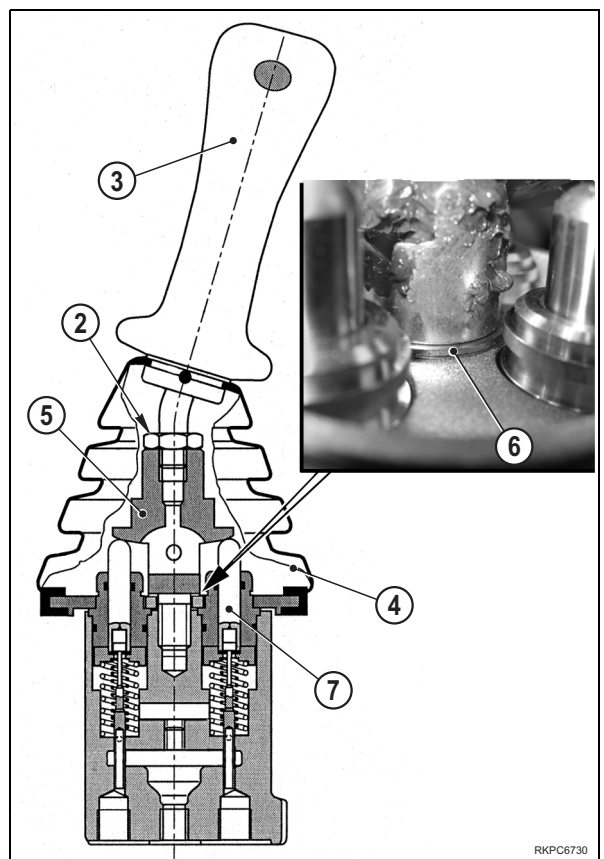

CLICK HERE TO **DOWNLOAD** THE COMPLETE MANUAL

- Thank you very much for reading the preview of the manual.
- You can download the complete manual from: www.heydownloads.com by clicking the link below



- Please note: If there is no response to CLICKING the link, please download this PDF first and then click on it.

CLICK HERE TO **DOWNLOAD** THE COMPLETE MANUAL

5. Pressurisation of the tank

- ★ This procedure should be performed every time the oil-refuelling cap is removed in order to remove hoses or other hydraulic equipment
- 1 -Start and run the engine at low idling and move the working equipment to the end of their travel as shown.
 - 2 -Stop the engine, loosen the tank plug (1) and then tighten the plug.
 - ★ This operation lets air into the tank when the level of the remaining oil is at minimum.
 - 3 -Start the engine and lower the working equipment to the ground

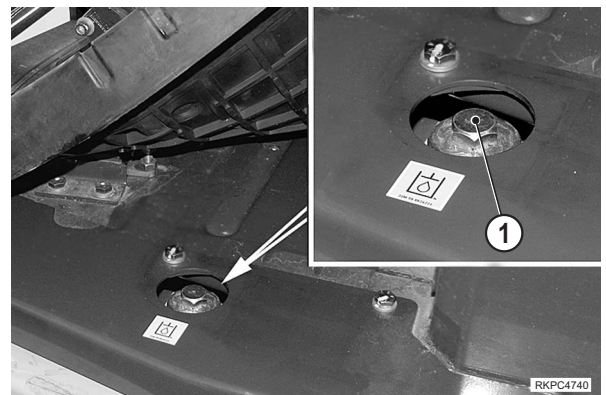
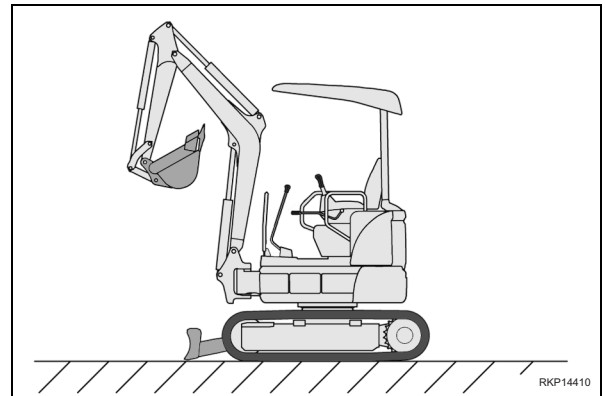

2 -While checking that the wiring and piping are not caught or damaged, pull down the floor slowly.

- ★ Do not put any part of your body under the floor while opening or closing the floor.

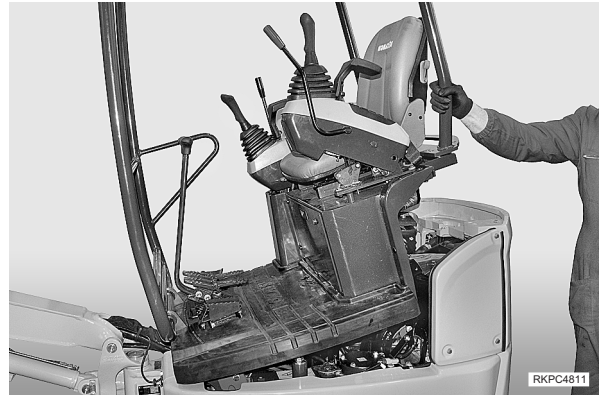

3 -Install 2 floor fixing bolts (2).

- ★ Replace screws if damaged.

 Screws: 157 -197 Nm

4 -Close engine rear cover.

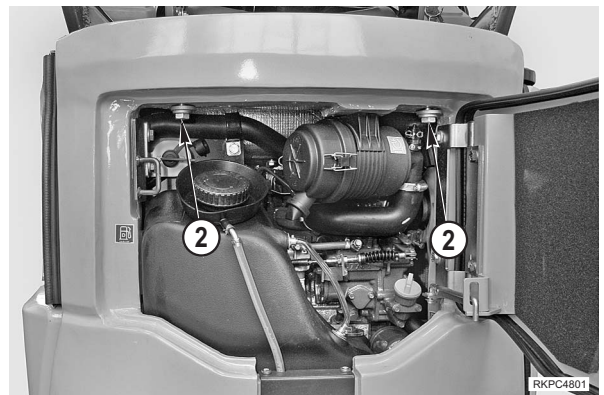

30 REMOVAL AND INSTALLATION

HOW TO READ THE MANUAL	3	SWIVEL JOINT	53
PRECAUTIONS TO BE TAKEN WHILE WORKING	4	• Removal.....	53
SPECIAL TOOLS	5	• Installation.....	55
CANOPY.....	7	SWING MOTOR.....	56
• Removal	7	• Removal.....	56
• Installation	8	• Installation.....	57
CABIN.....	9	HYDRAULIC OIL TANK	58
• Removal	9	• Removal.....	58
• Installation	11	• Installation.....	60
RADIATOR	12	SERVO-CONTROLS SUPPLY SOLENOID VALVE ...	61
• Removal	12	• Removal.....	61
• Installation	14	• Installation.....	61
HYDRAULIC OIL COOLER.....	15	RH PPC VALVE (BOOM - BUCKET)	62
• Removal	15	• Removal.....	62
• Installation	16	• Installation.....	65
COUNTERWEIGHT AND FUEL TANK.....	17	LH PPC VALVE (ARM - BUCKET).....	66
• Removal	17	• Removal.....	66
• Installation	20	• Installation.....	68
ENGINE-PUMP GROUP.....	21	UPPER FRAME SIDE SHIELD.....	69
• Removal	21	• Removal.....	69
• Installation	27	• Installation.....	70
HYDRAULIC PUMP.....	28	BLADE PPC VALVE.....	71
• Removal	28	• Removal.....	71
• Installation	29	• Installation.....	72
TRACKS	30	OPTIONAL EQUIPMENT PPC VALVE	73
• Removal	30	• Removal.....	73
• Installation	31	• Installation.....	73
IDLER WHEEL	32	BOOM SWING PPC VALVE.....	75
• Assembly.....	32	• Removal.....	75
PISTON - RECOIL SPRING - CYLINDER.....	33	• Installation.....	75
IDLER ROLLERS	36	TRAVEL PPC VALVE.....	77
• Removal	36	• Removal.....	77
• Installation	36	• Installation.....	78
• Assembly.....	37	FUNCTION SELECTION SOLENOID VALVE	
FLOOR.....	38	(HS version only).....	79
• Removal	38	• Removal.....	79
• Installation	44	• Installation.....	79
UPPER FRAME.....	47	TRAVEL MOTOR.....	80
• Removal	47	• Removal.....	80
• Installation	51	• Installation.....	80
SWING CIRCLE.....	52	• Assembly	81
• Removal	52	SPROCKET WHEEL	92
• Installation	52	• Removal.....	92
		• Installation.....	92

9 - Take out four screws and remove the heating assembly (14).

- ★ Place assembly on floor, leaving the cab deck edge clear.



10 - Remove the screws (13) previously left in for safety, raise and remove the whole cab (12).

- ⚠ Use caution and make sure that any members left on the floor do not get damaged.

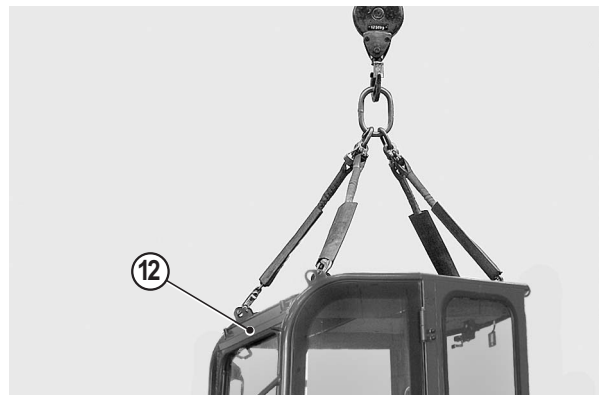

Installation

- To install, reverse the removal procedure.

ENGINE-PUMP GROUP

Removal

- ★ After disconnecting the hoses, plug the hoses and holes to prevent circuit contamination.

- ⚠ Eliminate all residual pressure.
(For details, see "20 CONTROLS AND ADJUSTMENTS").

1 -Remove canopy and frame side-guards. [*1]

2 -Tilt the floor (1) and engage lock pin. (For details, see "20 CONTROLS AND ADJUSTMENTS").

3 -Drain the fuel.

 Fuel: max. 19 ℓ

4 -Drain the coolant.

 Coolant:
with canopy: approx. 3.1 ℓ
with cab: approx 4.2 ℓ

5 -Drain the hydraulic oil.

 Hydraulic oil: approx 15.2 ℓ

6 -Disconnect hoses (2), (3) and remove suction filter (4). [*2]

7 -Open the rear door; loosen and remove the screws (5) and remove battery main switch assembly (6).

- ★ Place the assembly to one side.

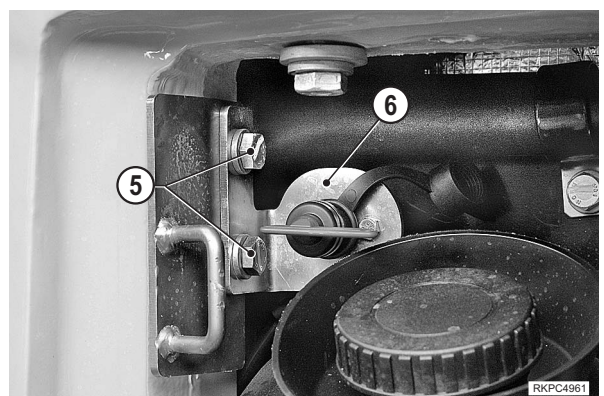
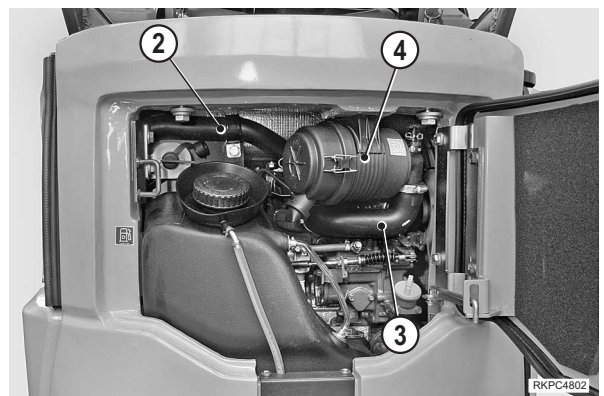
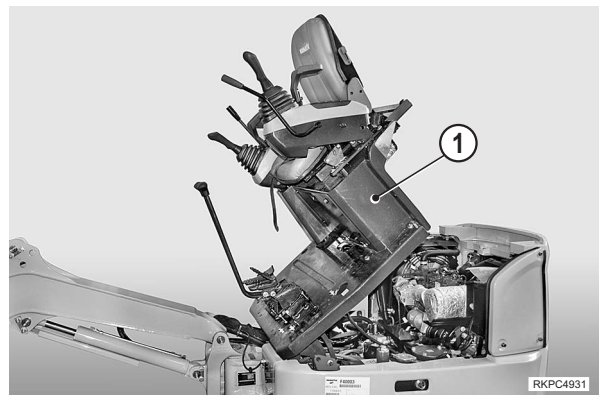

Installation

- To install, reverse the removal procedure.

[*1]

- ★ Adjust track tension.
(For details, see "20 CONTROLS AND ADJUSTMENTS").

15 -Working on the control valve, disconnect hoses coming from RH, LH and blade PPC valves (in all, 10 hoses relating to elements no. 1,2,5,6, and 7).

- ★ Check to ensure that all hoses have marks scribbled on, and note down their plugging positions.
- ★ Guard the quick connections and plug lines and holes to prevent contamination.

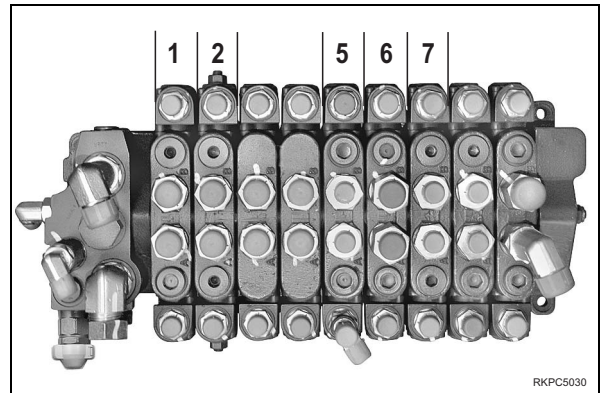

16 -Disconnect the servo-control feed and drain hoses (30), (31) (marked as **M** and **S** respectively). [*1]

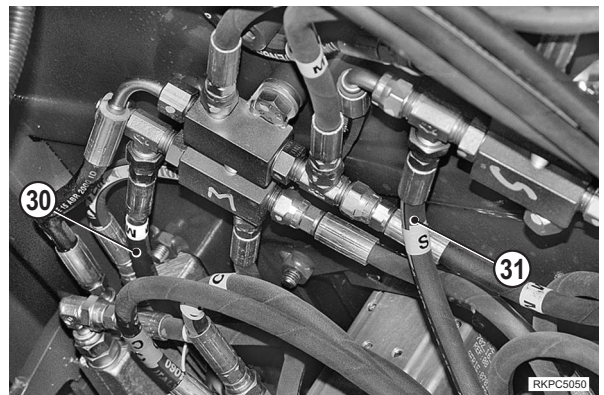

17 -Disconnect hoses (33), (34) from the optional equipment control PPC valve (32).

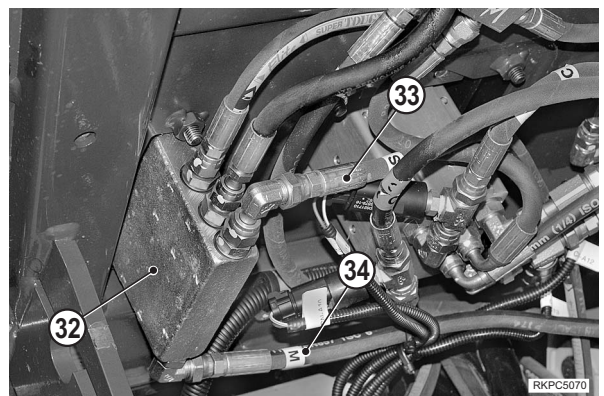

18 -Disconnect four hoses (36) from the travel PPC valve (35).

- ★ Note down the connection positions.

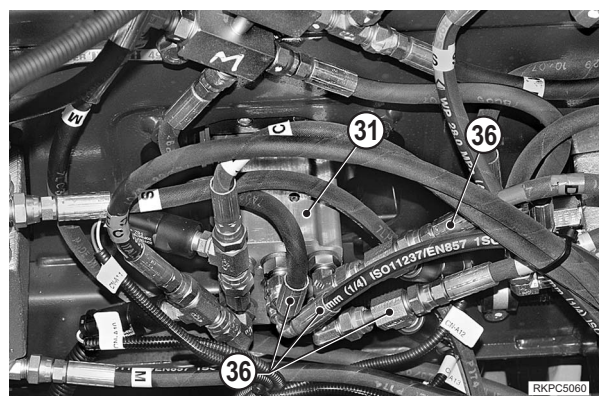

20 -Loosen and remove the frame retaining screws (32).
[*3]

21 -Slowly lift the frame (30) making sure that it is free from interfering parts and paying attention not to damage the swivel joint.



Full frame: 146 kg

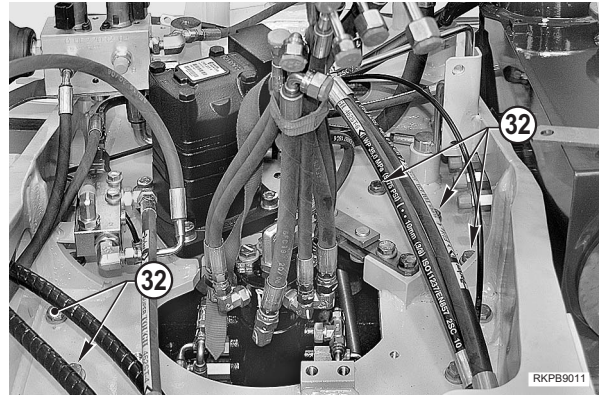

Installation

- To install, reverse the removal procedure.

[*1]



Base side pin and swivel support surfaces:
ASL800040



Head side pin and protection: ASL800050

[*2]



Screws: Loctite 262



Screws: 65 -72 Nm

[*3]



Screws: Loctite 262



Screws: 65.7 Nm

1 - Fill tank up to maximum level; start the engine to allow the oil to flow, then top up.



Hydraulic oil: approx 15.2 ℓ

2 - Bleed air from all cylinders and pressurize the system.

SERVO-CONTROLS SUPPLY SOLENOID VALVE

Removal

- ★ Package for vehicle with travel increment shown.
On PC14R-3, the package contains only the servo-controls solenoid valve.

- 1 -Release all residual pressure and drain the hydraulic oil.



Hydraulic oil: 15.2 ℓ

- 2 -Tilt the floor (1) and engage the lock pin.
(For details, see "20 CONTROLS AND ADJUSTMENTS").

- 3 -Mark the positions and disconnect the connectors (2), (3).

- 4 -Disconnect the increment hose and the servo-control hose (5), (6) from the feed and drain bundle (4).

- ★ Plug lines and holes to prevent contamination.

- 5 -Remove the lower screws and remove the complete package (7).

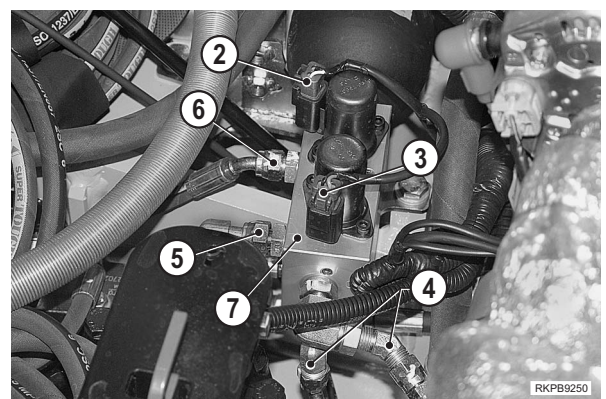
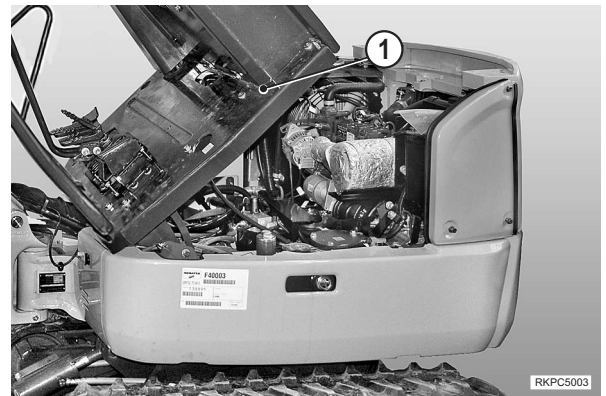

Installation

- To install, reverse the removal procedure.

- 1 -Fill hydraulic oil tank.



Hydraulic oil: approx 15.2 ℓ

- 2 -Start and run engine at low idling speed for a few minutes; stop the engine and check the oil level in the tank.

- 3 -Bleed air from all circuits and pressurize the system.
(For details, see "20 CONTROLS AND ADJUSTMENTS").

BLADE PPC VALVE

Removal

- 1 -Remove instrument panel (see "RH PPC VALVE (BOOM - BUCKET)") and release residual pressure.
- 2 -Tilt the floor (1) and engage the lock pin.
(For details, see "20 CONTROLS AND ADJUSTMENTS").

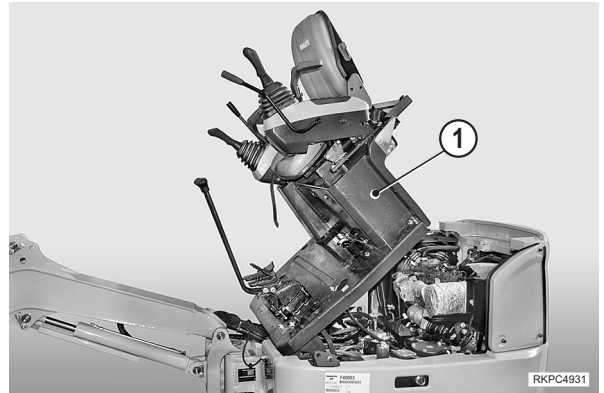

- 3 -Disconnect hose (2) (M white), (3) (S white) from distribution blocks.

★ Plug lines and holes to prevent contamination.

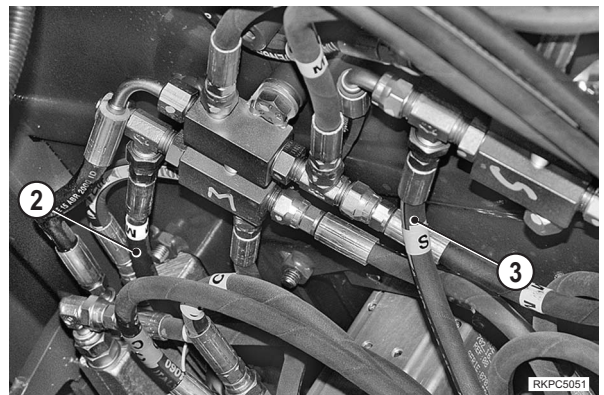

- 4 -Remove the front guard (4) protecting the PPC lines and cut the strap (5) retaining the servo-control lines.

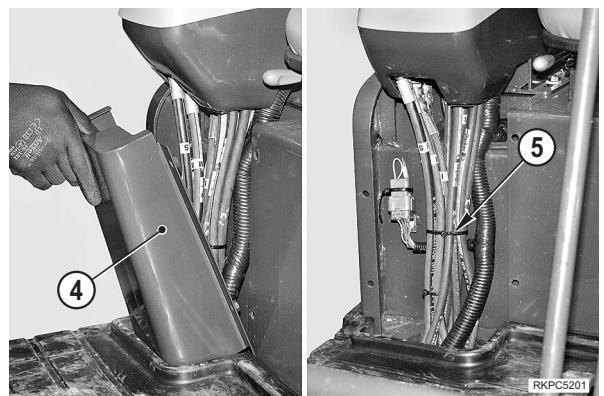

- 5 -Remove screws (6) and remove the PPC valve (7) and hoses.

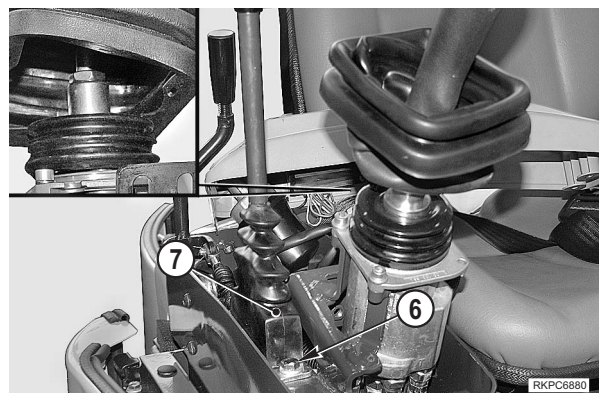

TRAVEL MOTOR (with increment)

Assembling

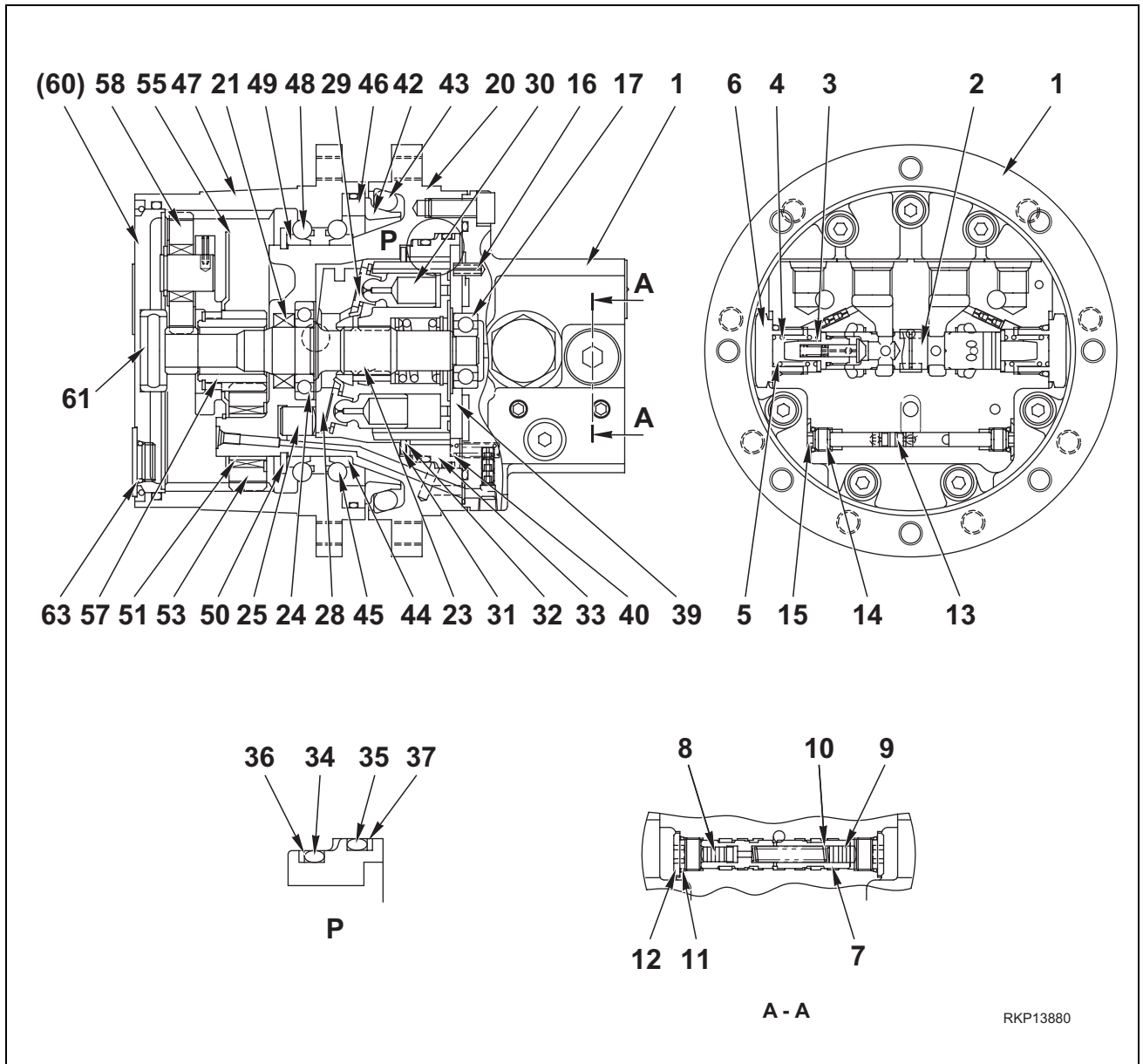

★ Only the assembly procedure will be described.

1. Hydraulic motor section

- Body 1 (1)

★ The parts other than the O-rings are supplied only as the parts of body 1 sub-assembly.

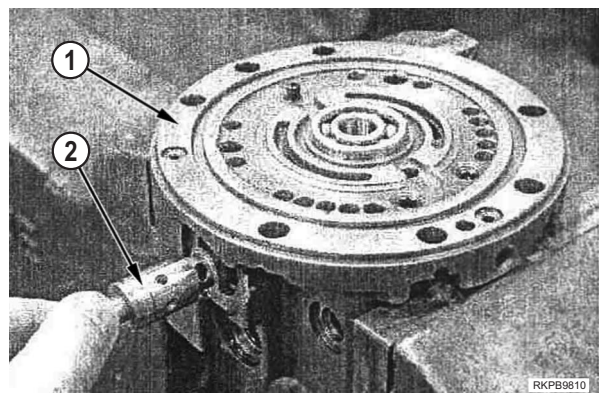

11 -Insert slide ring (61) in cover (60).

 Slide ring: ASL800050 For fitting the slide ring to the cover

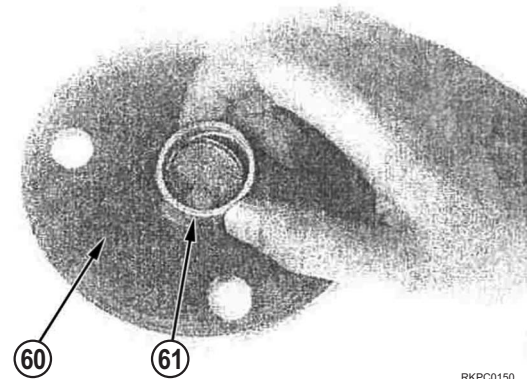

RKPC0150

12 -Supply hydraulic oil and install cover (60).

 Body (47) : Hydraulic oil (approx.300 cm³)

- ★ Take care not to damage the O-ring.
- ★ Match the letters of "DRAIN" on the cover to the cut of the body. (A)

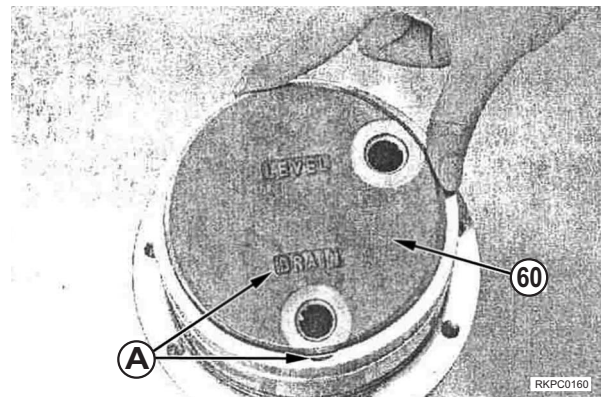

RKPC0160

13 -Install O-snap ring (62) to fix cover (60).

- ★ Use a flat bladed screwdriver on the edge of the snap ring to drive in the ring following the contour of the body (47).

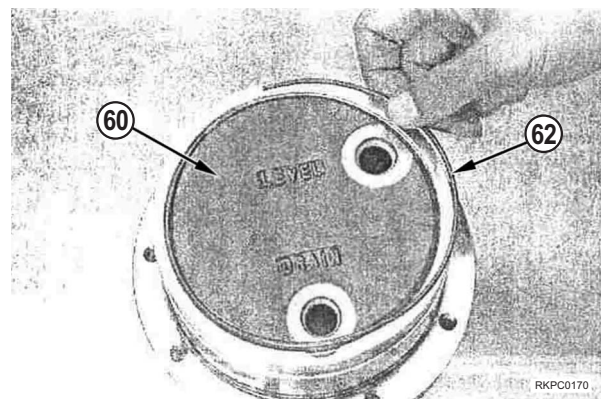

RKPC0170

14 -Tighten socket head plugs (63) (G3/8).

- ★ Tighten the plug on the side of the letters of "DRAIN" first. (Lock the cover with the flange of the plug.)

 Plug: 46 – 51 Nm {4.7 – 5.2 kgm}
(Width across flats of hexagon socket head: 8 mm)

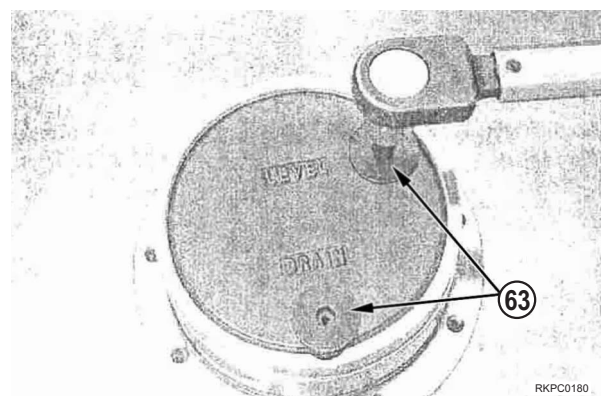

RKPC0180

BLADE CYLINDER

Removal

! Lower the working equipment to the ground with all safety devices engaged. Rest the back of the bucket on the ground with the arm in a vertical position.

1 - Remove the protection (1).

★ Place a supporting block «A» beneath the cylinder «A».

2 - Stop the engine, release the pressures in the cylinder (2) by moving the command lever several times in both directions.

3 - Remove the pin (3). [*1] [*3]

★ Note down position of any shims and direction of assembly.

4 - Start the engine to retract the piston (4). [*2]

5 - Stop the engine and release the residual hydraulic pressures. (For details, see "20 CONTROLS AND ADJUSTMENTS").

6 - Disconnect the tubes (5) and plug them. Also plug the holes in the cylinder (2) to prevent entry of impurities.

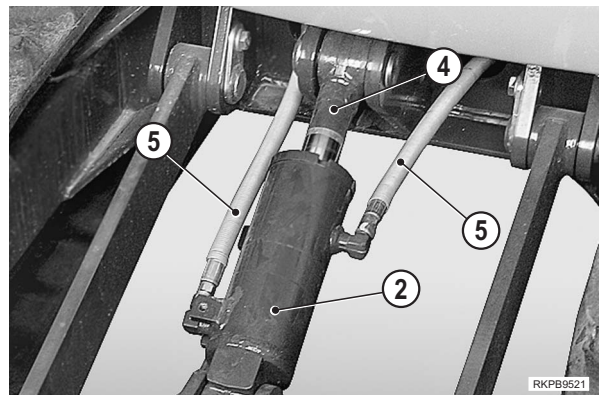
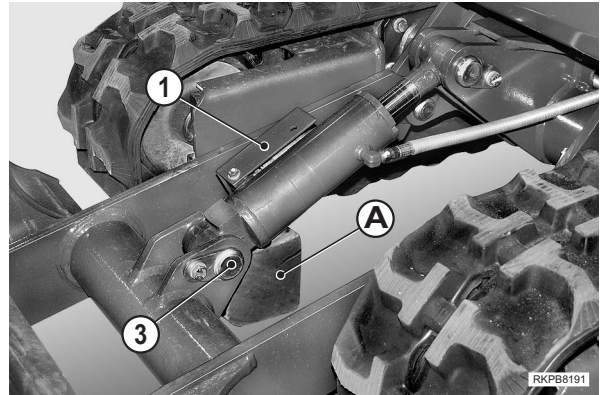

7 - Remove the pin (6). [*1] [*2] [*3]

8 - Remove the cylinder (2).

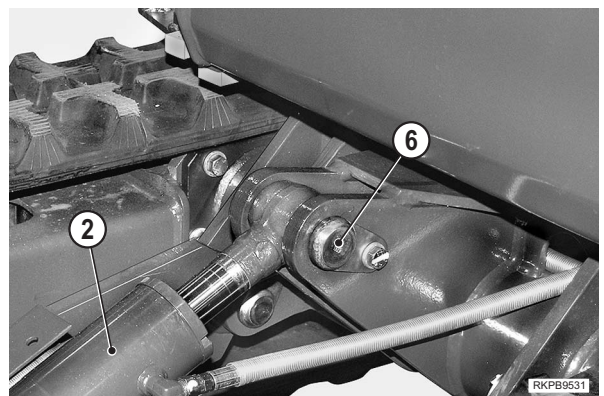

Installation

• To install, reverse the removal procedure.

[*1]

★ Insert the shims.

[*2]

! When aligning the positions between the hole and the pin, do not insert fingers in the holes to check alignment.

[*3]

 Internal bushings: ASL800040

1 - Start the engine and bleed the air from the cylinder. (For details, see "20 CONTROLS AND ADJUSTMENTS").

★ After bleeding the air, check the oil level in the tank.

Installation

- To install, reverse the removal procedure.

[*1]

- ★ Check the centering and the smooth movement of the protection (1).

 Shoes and guides: ASL800050

[*2]

- ★ Insert the shims.

[*3]

- ⚠ When aligning the positions between the hole and the pin, turn the engine over at low idling. Do not insert fingers in the holes to check alignment.

[*4]

- ★ Insert the shims.

 Internal bushings: ASL800040

- Start the engine to circulate the oil and bleed the air from the cylinder.
 - ★ When bleeding is complete, stop the engine. Check the oil level in the tank and pressurize the hydraulic system.
(For details, see "20 CONTROLS AND ADJUSTMENTS").

- 8 - Loosen the locknuts (6) and unscrew the spacer (7) until it is released from the moving frame (8).

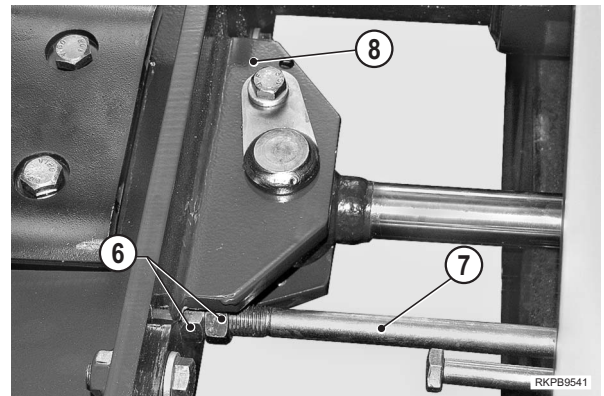

- 9 - Using a fork lift, support the whole moving frame (8) and slide it off.



Full moving frame:
with rubber track: approx. 105 kg
with iron track: approx 138 kg



Installation

- To install, reverse the removal procedure.
- 1 - Check maximum spreading by measuring the gap "D" between the moving and fixed frames; this can be adjusted with spacer (7). Lock into position with locknuts (6).
- ★ Size of "D": 249.5±05 mm

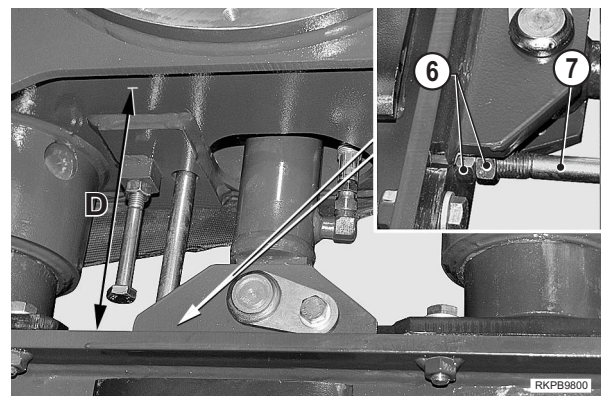

CLICK HERE TO **DOWNLOAD** THE COMPLETE MANUAL

- Thank you very much for reading the preview of the manual.
- You can download the complete manual from: www.heydownloads.com by clicking the link below



- Please note: If there is no response to CLICKING the link, please download this PDF first and then click on it.

CLICK HERE TO **DOWNLOAD** THE COMPLETE MANUAL