

# Shop Manual

ARTICULATED  
DUMP TRUCK

**HM400-2**

SERIAL NUMBERS 2001 and up

**ecot3**

**KOMATSU**

CLICK HERE TO **DOWNLOAD** THE COMPLETE MANUAL

- Thank you very much for reading the preview of the manual.
- You can download the complete manual from: [www.heydownloads.com](http://www.heydownloads.com) by clicking the link below



- Please note: If there is no response to CLICKING the link, please download this PDF first and then click on it.

CLICK HERE TO **DOWNLOAD** THE COMPLETE MANUAL

Failure code [CA2249] Low pressure in supply pump 2.....	44
Failure code [CA2271] Abnormally high signal voltage in EGR valve lift sensor .....	46
Failure code [CA2272] Abnormally low signal voltage in EGR valve lift sensor.....	48
Failure code [CA2351] Short circuit in EGR valve solenoid drive circuit.....	50
Failure code [CA2352] Disconnection in EGR valve solenoid drive circuit .....	52
Failure code [CA2555] Disconnection in intake air heater relay .....	52
Failure code [CA2556] Short circuit in intake air heater relay .....	54
Troubleshooting by failure code, Part 5 .....	SEN01112-01
Failure code [DAF9KM] Wrong connection of connector .....	3
Failure code [DAFRKR] Trouble in CAN communication (machine monitor) .....	4
Failure code [DAQ0KK] Lowering of source voltage.....	6
Failure code [DAQ0KT] Trouble in non-volatile memory.....	8
Failure code [DAQ2KK] Trouble in solenoid power supply system .....	10
Failure code [DAQ9KQ] Disagreement of model selection (Transmission controller).....	12
Failure code [DAQRKR] Trouble in CAN communication (Transmission controller).....	14
Failure code [DAQRMA] Disagreement of option setting (Transmission controller) .....	16
Failure code [DB10KT] Trouble in non-volatile memory.....	16
Failure code [DB12KK] Trouble in solenoid power supply system .....	18
Failure code [DB13KK] Lowering of battery direct voltage.....	20
Failure code [DB19KQ] Disagreement of model selection (Retarder controller).....	22
Failure code [DB1QMA] Disagreement of option setting (Retarder controller) .....	22
Failure code [DB1RKR] Trouble in CAN communication (Retarder controller).....	24
Failure code [DB2RKR] Trouble in CAN communication (Engine controller).....	26
Failure code [DD1ML4] Disagreement of accelerator-linked retarder switch signal.....	28
Failure code [DDTHKA] Trouble in Hi clutch flow sensor valve .....	30
Failure code [DDTJKA] Trouble in Lo clutch flow sensor valve.....	31
Failure code [DDTKKA] Trouble in 1st clutch flow sensor valve .....	32
Failure code [DDTLKA] Trouble in 2nd clutch flow sensor valve .....	33
Failure code [DDTMKA] Trouble in 3rd clutch flow sensor valve .....	34
Failure code [DDTNKA] Trouble in reverse clutch flow sensor valve.....	35
Failure code [DF10KA] Input of no lever signals.....	36
Failure code [DF10KB] Input of multiple lever signals .....	40
Failure code [DGF1KX] Transmission oil temperature out of range.....	44
Failure code [DGR2KZ] Ground fault in brake oil temperature sensor (rear).....	46
Failure code [DGR2L8] Disconnection in brake oil temperature sensor (rear) .....	48
Failure code [DGR3KZ] Ground fault in brake oil temperature sensor (center).....	50
Failure code [DGR3L8] Disconnection in brake oil temperature sensor (center).....	52
Failure code [DGR4KZ] Ground fault in brake oil temperature sensor (front).....	54
Failure code [DGR4L8] Disconnection in brake oil temperature sensor (front).....	56
Failure code [DGR6KX] Steering oil temperature out of range .....	58
Troubleshooting by failure code, Part 6 .....	SEN01113-01
Failure code [DGT1KX] Short circuit in torque converter oil temperature sensor system.....	4
Failure code [DHT5KX] Disconnection, ground fault, or short circuit in torque converter oil pressure sensor system .....	6
Failure code [DHT5L6] Trouble in torque converter oil pressure sensor.....	8
Failure code [DHU2KX] Trouble in accumulator oil pressure sensor (front) system .....	10
Failure code [DHU3KX] Trouble in accumulator oil pressure sensor (rear) system.....	12
Failure code [DJF1KA] Disconnection in fuel level sensor system .....	14
Failure code [DK51L5] Trouble in manual retarder potentiometer and RVS .....	16
Failure code [DK52KX] Trouble in dump lever potentiometer 1 .....	18
Failure code [DK53L8] Trouble in dump lever potentiometer 2.....	20
Failure code [DK54KX] Trouble in dump positioner sensor .....	22
Failure code [DKH0KX] Pitch angle sensor signal out of range.....	24
Failure code [DLF1KA] Disconnection in transmission input shaft speed sensor.....	26
Failure code [DLF1LC] Trouble in transmission input shaft speed sensor.....	27
Failure code [DLF2KA] Disconnection in transmission intermediate shaft speed sensor system .....	28

Testing and adjusting item	Symbol	Part No.	Part name	Qty	Remarks
Removal and installation of engine coolant temperature sensor	-	Commercially available	Socket	1	21 mm deep socket (MITOLOY 4ML 21 or equivalent) Applicable engine serial No.:530056–534132
		795T-981-1010	Socket	1	19 mm deep socket (MITOLOY 4ML 19 or equivalent) Applicable engine serial No.:534133 and up

\*: Included in 799-601-9000 and 799-601-9200

\*%: Included in 799-601-4101 and 799-601-4201

- ★ For types and part numbers for T-branch boxes and T-branch adapters for troubleshooting for machine monitor, controller, sensor, actuator, electrical parts and wiring harness, see "T-branch box and T-branch adapter table" in the troubleshooting section, General information on troubleshooting.

## Testing blow-by pressure

★ Testing instrument for blow-by pressure

Symbol	Part number	Part name
F	799 - 201 - 1504	Blow-by checker

⚠ **Stop the machine on the level ground, turn the parking brake switch ON, and set chocks to the tires.**

1. Remove engine under cover (small).
2. Install nozzle [1] and hose [2] to blow-by hose (1) and connect to gauge [3].

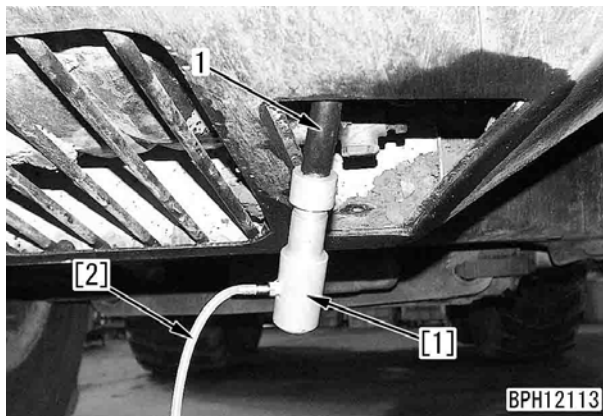

6. When the testing is completed, remove the instruments and set to the original condition.

3. Start the engine and raise the coolant temperature of the engine to the operating range.
4. Turn the parking brake switch ON, depress the brake pedal and set the gear shift lever to the D position.
 

⚠ **If the gearshift lever is operated to any position other than the D position, the machine may move off even if the brake is being depressed, so always test at the D position.**
5. Depress the accelerator pedal gradually and check blow-by pressure while the engine is running at high idle and the torque converter is stalling.
 

⚠ **There is danger of damage to the internal parts of the transmission, so never operate the gear shift lever to any position other than the D position during the stall operation.**

★ After completing the test, lower the engine speed to low idle, then return the gearshift lever to the N position.

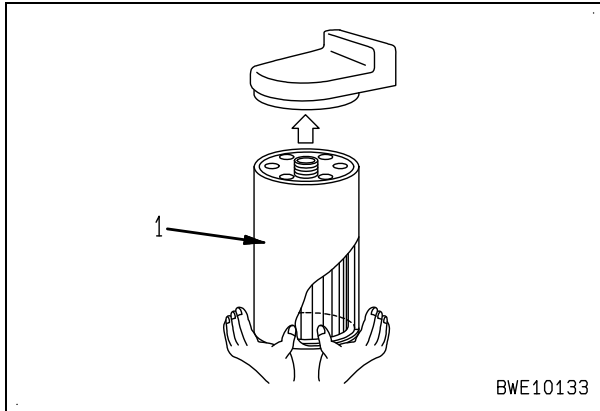

4. Remove air bleeding plug (3) of fuel main filter (2) and operate priming pump (4).

★ Operate until fuel flows through plug hole and when fuel is confirmed, install the plug.

🔧 Air bleeding plug:

7.8 – 9.8 Nm {0.8 – 1.0 kgm}

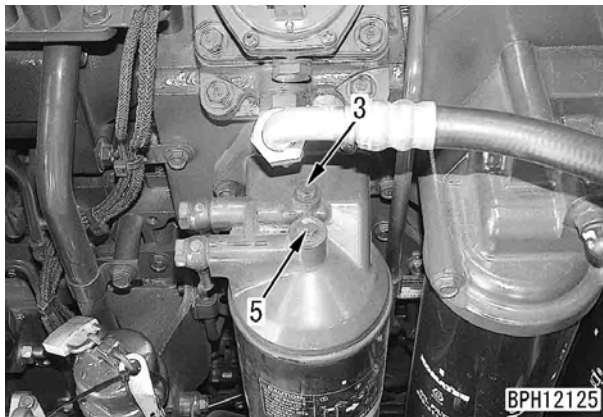

5. Remove air bleeding plug (5) of fuel main filter and operate priming pump (4).

★ Operate until fuel flows through plug hole and when fuel is confirmed, install the plug.

🔧 Air bleeding plug:

7.8 – 9.8 Nm {0.8 – 1.0 kgm}

6. Loosen supply pump air bleeder (6) and operate priming pump (4) 90 – 100 times.

★ Operate priming pump until fuel flows through bleeder and when fuel is confirmed, tighten bleeder and operate several times more until priming pump becomes stiff.

★ Air bleeder: 4.9 – 6.9 Nm {0.5 – 0.7 kgm}

7. Crank the engine with the starting motor and start the engine.

★ The air in the high-pressure circuit is bled automatically if the engine is cranked.

★ If the engine does not start, there still may be air in the low-pressure circuit. In this case, repeat the above procedure from step 4.

### Torque converter related

#### 2. Testing torque converter inlet pressure

- 1) Install hose [1] of hydraulic tester K1 to oil pressure inspecting coupler (2).

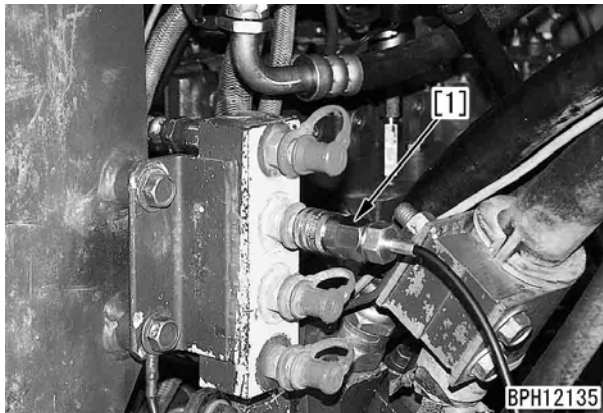

- 2) Connect hydraulic tester K2.
- 3) Start the engine and raise the temperature of the torque converter oil to the operating range.
- 4) While keeping the gear shift lever at the N position, inspect the oil pressure at high idle.



- 5) When the test is completed, remove the instruments and restore to the original condition.

#### 3. Testing torque converter outlet pressure

- 1) Tilt the cab up.
- 2) Remove oil pressure inspecting plug (3), then install nipple [1] and hose [2] of hydraulic tester K1.
  - ★ Pull the hose out to the rear of the transmission.

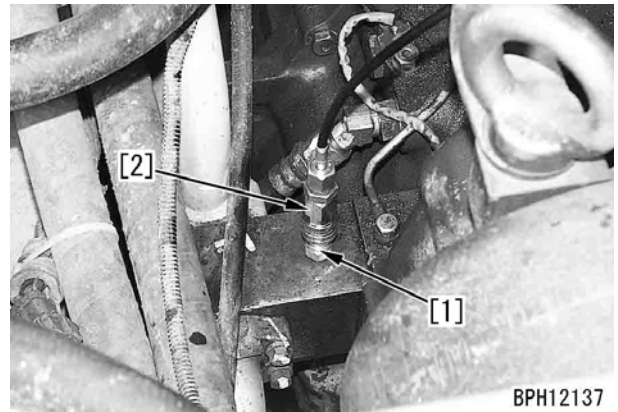

- 3) Tilt the cab down and return it to its original position.
- 4) Connect oil pressure gauge [3] of hydraulic tester K1.
  - ★ If oil pressure gauges are of the analog type, use the one with rated pressure 6 MPa {60 kg/cm<sup>2</sup>}.
- 5) Start the engine and raise the temperature of the torque converter oil to the operating range.
- 6) While keeping the gear shift lever at the N position, inspect the oil pressure at high idle. When operate retarder control lever at actuation position and release position.



- 7) When the test is completed, remove the instruments and restore to the original condition.

3. Adjusting the differential lock oil pressure for rear axle
- ★ If the rear axle differential lock oil pressure is not normal, adjust it with relief valve (13) of rear differential lock valve according to the following procedures.

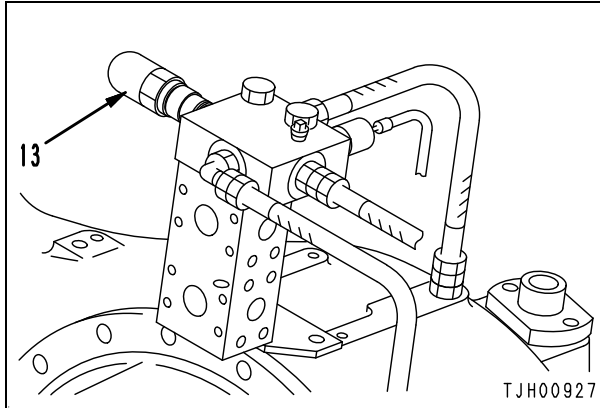

- ★ Procedure for adjustment is the same as for center differential lock valve.

Charging accumulator with nitrogen gas chart

Ambient temperature °C	Charging nitrogen gas		Remarks
	Mpa	kg/cm <sup>2</sup>	
15	4.34	44.2	
16	4.35	44.4	
17	4.37	44.5	
18	4.38	44.7	
19	4.40	44.8	
20	4.41	45.0	Standard gas pressure
21	4.43	45.2	
22	4.44	45.3	
23	4.46	45.5	
24	4.47	45.6	
25	4.49	45.8	
26	4.50	45.9	
27	4.52	46.1	
28	4.53	46.2	
29	4.55	46.4	
30	4.56	46.5	
31	4.58	46.7	
32	4.59	46.8	
33	4.61	47.0	
34	4.62	47.2	
35	4.64	47.3	
36	4.65	47.5	
37	4.67	47.6	
38	4.68	47.8	
39	4.70	47.9	
40	4.71	48.1	
41	4.73	48.2	
42	4.74	48.4	
43	4.76	48.5	
44	4.77	48.7	
45	4.79	48.8	

t = Gas temperature at time of charge (°C)  
Reference: t may be assumed to be ambient temperature.

9. After the accumulator is charged to the standard pressure, close the valve of nitrogen gas cylinder (c).
  - If the accumulator is charged too much, turn handle (b) to the left slowly with the valve of nitrogen gas cylinder (c) closed to release the nitrogen gas gradually to adjust.

10. Remove gas charge tool R1 from valve (4) of accumulator (1) according to the following procedure.

- 1) Turn handle (a) to the left to close the valve of the accumulator.
- 2) Turn handle (b) to the left to open and discharge nitrogen gas remaining in gas charge tool R1 and hoses.
- 3) Remove gas charge tool R1 from valve (4) of the accumulator.

11. Apply soap water to valve (4) of the accumulator to check that nitrogen gas is not leaking.

12. Install cap (3) and valve guard (2) to accumulator (1).

Cap: 9.8 – 12.7 Nm {1.0 – 1.3 kgm}

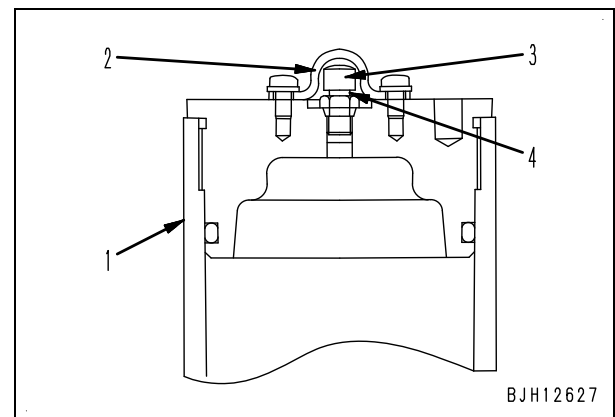

13. In a week after charging the accumulator with nitrogen gas, check that the nitrogen gas pressure has not lowered.

- ★ Check the functions in 5 minutes after stopping the engine. (If the engine is stopped for more than 5 minutes, the brake circuit pressure lowers and the functions cannot be checked accurately.)
- 1) Stop the machine on a level place and set the parking brake switch in the "PARK" position.
  - 2) Start the engine and run it at medium speed for 1 minute and then stop it.
  - 3) Turn the starting switch to the ON position and press the brake pedal repeatedly. Count the number of presses until the brake oil pressure caution lamp lights up.
    - If number of presses is less than 5: Accumulator gas pressure may have lowered.
    - If number of presses is 5 or more: Accumulator gas pressure is normal.

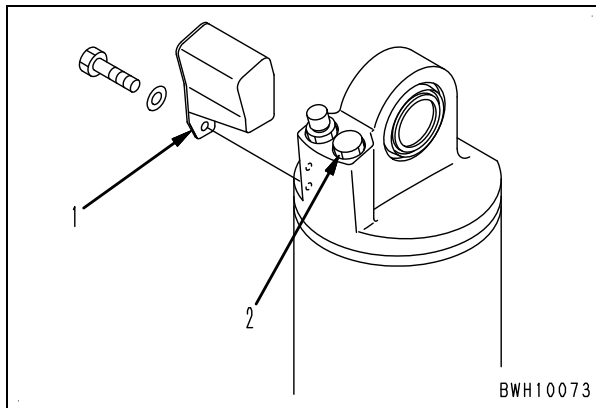

- 4) Operate the hydraulic jack to lower the frame slowly until the suspension cylinder is retracted to the specified oil volume length.

**⚠ Operate the hydraulic jack carefully to prevent the suspension cylinder from being retracted too far and suffering damage.**

- ★ Specified front oil volume length (a):  
53±3 mm
- ★ Specified rear oil volume length (b):  
66±3 mm

### 3. Adjusting of oil level

- ★ Adjust the oil level after completing the release of nitrogen gas.

- 1) Check that the suspension cylinder is the specified oil volume length.

- ★ Specified front oil volume length (a):  
53±3 mm
- ★ Specified rear oil volume length (b):  
66±3 mm

**⚠ Operate the hydraulic jack carefully.**

- 2) Remove oil level valve (2).  
 3) Remove the valve body from gas supply valve (3), and then install joint P6.  
 4) Install fitting P5 to joint P4, and then connect hose P3 and pump P2.  
 5) Operate pump P2 to release the gas from the mounting port of oil level valve (2).  
 ★ Keep sending oil to let the inside oil flow out from the mounting port until the oil without air bubbles flow out.  
 ★ Front cylinder oil charge amount (reference): 6.0 ℓ  
 ★ Rear cylinder oil charge amount (reference): 4.2 ℓ  
 6) Install oil level valve (2).

Oil level valve:

39.2 - 49.0 Nm {4 - 5 kgm}

- 7) Remove suspension tools P2 to P5, and then remove gas supply valve (3).

Air intake valve:

39.2 - 49.0 Nm {4 - 5 kgm}

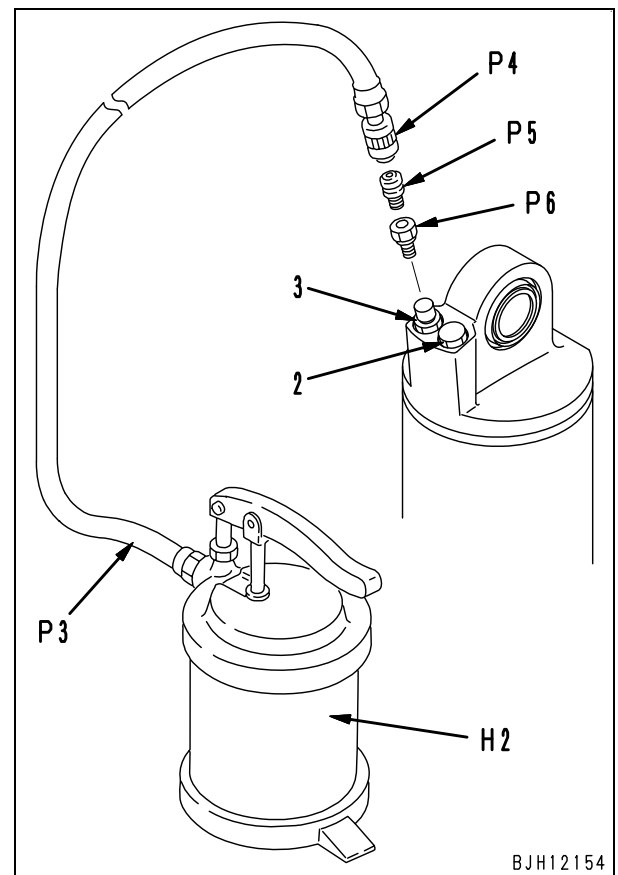

### 4. Charging with nitrogen gas

- ★ Charge with nitrogen gas after completing the adjustment of oil level.

- 1) Remove the cap at the top of air supply valve (3).

- 2) Connect suspension tools P7 to P12 as shown in the figure.

- ★ Connect joint P10 to the air supply valve.
- ★ Before installing the regulator, blow the filter at the mouthpiece thoroughly with nitrogen gas (min. 0.98 MPa {10 kg/cm<sup>2</sup>}) to prevent the entry of foreign materials.

- 3) Open valve [2] of nitrogen gas cylinder [1] and check the pressure (internal pressure of the cylinder) indicated by gauge P12.

- ★ The indicated pressure must be higher than the internal pressure of the cylinder by at least 0.98 MPa {10 kg/cm<sup>2</sup>}.

- ★ Cylinder internal pressure  
 Front: 4.31 MPa {44.0 kg/cm<sup>2</sup>}  
 Rear: 1.18 MPa {12.0 kg/cm<sup>2</sup>}

## Method for emergency escape at electrical system failure

If any problem occurs in the electrical system of the engine or transmission control system, it may disable the engine to start or the machine to move off.

If such a problem occurs, temporarily restore the engine or transmission electrical system to move the machine to a safe place, then carry out regular troubleshooting.

1. When any problem occurs in the engine control system and the engine cannot be started:
  - ★ Decide the escape method according to the following flowchart.
  - ★ Refer to "Special functions of machine monitor" for the method of checking the failure code.

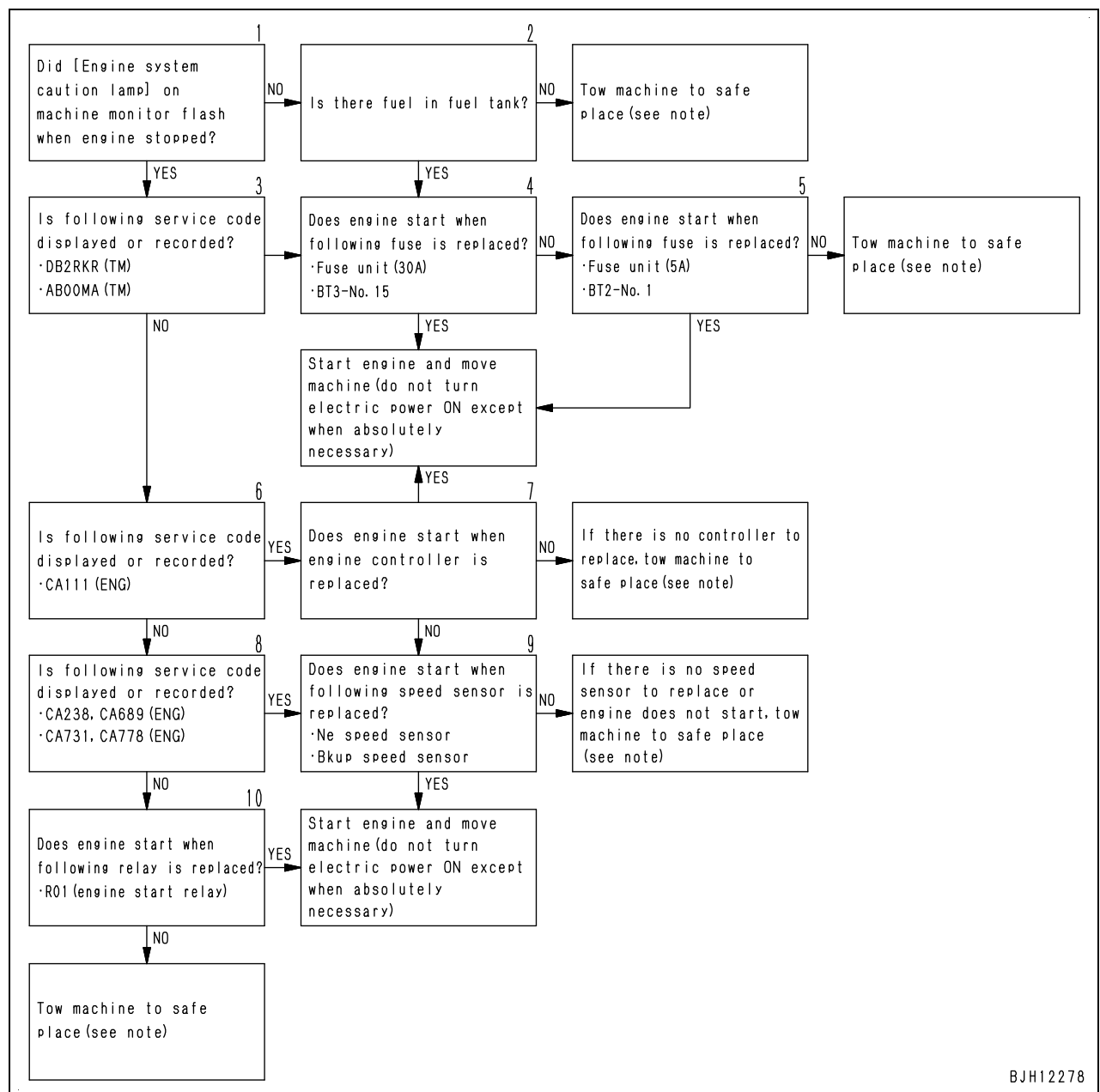

Note: If the engine cannot be started and the machine is to be towed, release the parking brake temporarily referring to "Method for emergency release of parking brake", since it cannot be released by operating the switch.

## Classification and procedures for troubleshooting

### Classification of troubleshooting

Type	Contents
Display of code	Troubleshooting by failure code
E mode	Troubleshooting of electrical system
H mode	Troubleshooting of hydraulic and mechanical system
S mode	Troubleshooting of engine

### Procedure for troubleshooting

If a phenomenon looking like a trouble occurs in the machine, select a proper troubleshooting No. according to the following procedure, and then go to the corresponding troubleshooting section.

1. Procedure for troubleshooting to be taken when action code and failure code are displayed on machine monitor:  
 If a action code and a failure code are displayed on the machine monitor, carry out the troubleshooting for the corresponding "Display of code" according to the displayed failure code.
2. When electrical system failure code or mechanical system failure code is recorded in fault history:  
 If a action code and a failure code are not displayed on the machine monitor, check for a mechanical system failure code and an electrical system failure code with the fault history function of the machine monitor.  
 If a failure code is recorded, carry out troubleshooting for the corresponding "Display of code" according to that code.

  - ★ If an electrical system failure code is recorded, delete all the codes and reproduce them, and then see if the trouble is still detected.
  - ★ A failure code of the mechanical system cannot be deleted.
3. When action code or failure code is not displayed and no failure code is recorded in fault history:  
 If a action code or a failure code is not displayed on the machine monitor and no failure code is recorded in the fault history, a trouble that the machine cannot find out by itself may have occurred in the electrical system or hydraulic and mechanical system.  
 In this case, check the phenomenon looking like a trouble again and select the same phenomenon from the table of "Phenomena supposed to show troubles", and then carry out troubleshooting corresponding to that phenomenon in the "**E mode**", "**H mode**", or "**S mode**".

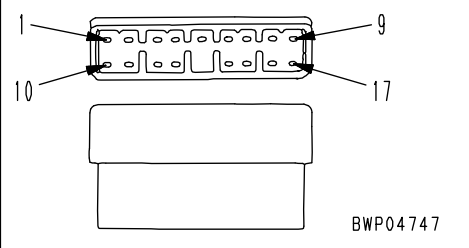
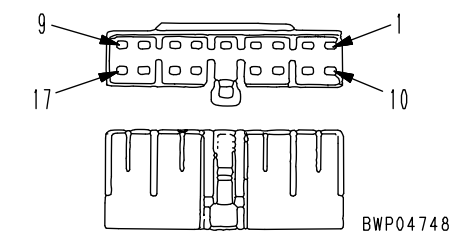
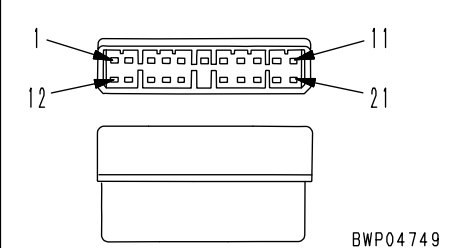
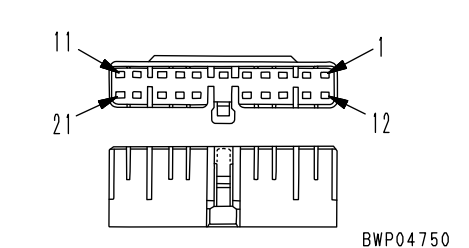
MIC type connector			
No. of pins	Male (female housing)	Female (male housing)	Testing connection use special tool Part No.
17	 <p style="text-align: right;">BWP04747</p>	 <p style="text-align: right;">BWP04748</p>	799-601-2730 (T-adapter)
	Body part No. : 79A-222-2730 (Q' ty:2)	Body part No. : 79A-222-2720 (Q' ty:2)	
21	 <p style="text-align: right;">BWP04749</p>	 <p style="text-align: right;">BWP04750</p>	799-601-2740 (T-adapter)
	Body part No. : 79A-222-2750 (Q' ty:2)	Body part No. : 79A-222-2740 (Q' ty:2)	
	Terminal part No. : 79A-222-2770 (Q' ty:50)	Terminal part No. : 79A-222-2760 (Q' ty:50)	

B4D18197

[The pin No. is also marked on the connector (electric wire insertion end)]

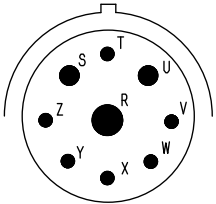
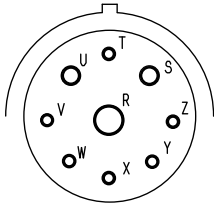
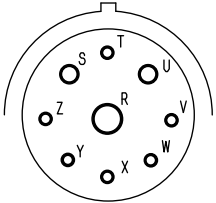
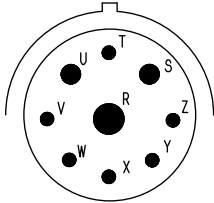
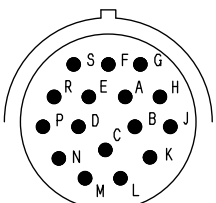
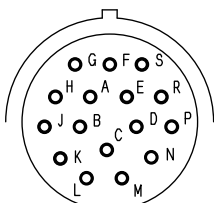
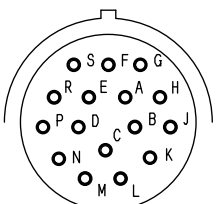
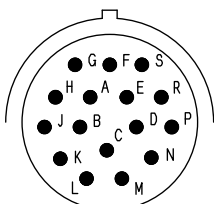
Type (shell size code)	HD30 Series connector		
	Body (plug)	Body (receptacle)	Testing connection use special tool Part No.
24-9 (5)	Pin (male terminal)	Socket (female terminal)	799-601-9250 (T-adapter)
			
	BWP05017	BWP05018	
	Part No. :08191-51201, 08191-51202	Part No. :08191-54101, 08191-54102	
24-16 (6)	Socket (female terminal)	Pin (male terminal)	799-601-9260 (T-adapter)
			
	BWP05019	BWP05020	
	Part No. :08191-52201, 08191-52202	Part No. :08191-53101, 08191-53102	
24-16 (6)	Pin (male terminal)	Socket (female terminal)	799-601-9260 (T-adapter)
			
	BWP05021	BWP05022	
	Part No. :08191-61201, 08191-62202, 08191-61205, 08191-62206	Part No. :08191-64101, 08191-64102, 08191-64105, 08191-64106	
24-16 (6)	Socket (female terminal)	Pin (male terminal)	799-601-9260 (T-adapter)
			
	BWP05023	BWP05024	
	Part No. :08191-62201, 08191-62202, 08191-62205, 08191-62206	Part No. :08191-63101, 08191-63102, 08191-63105, 08191-63106	

B4D18407

AMP connector for pump controller (CH700)		
No. of pins	PC200/220-8, PC270-8, PC300-8, PC400-8, PC128/138US-8 and so on	Testing connection use special tool Part No.
81	<p>Controller side (plug)</p>	799-601-4280 (Socket)
	<p>Harness side (receptacle)</p>	
	<p>Part No. : 7880-70-9040</p>	
40	<p>Controller side (plug)</p>	799-601-4280 (Socket)
	<p>Harness side (receptacle)</p>	
	<p>Part No. : 7880-70-9010</p>	

B4D184T7

CLICK HERE TO **DOWNLOAD** THE COMPLETE MANUAL

- Thank you very much for reading the preview of the manual.
- You can download the complete manual from: [www.heydownloads.com](http://www.heydownloads.com) by clicking the link below



- Please note: If there is no response to CLICKING the link, please download this PDF first and then click on it.

CLICK HERE TO **DOWNLOAD** THE COMPLETE MANUAL



### Location and connection of fuse (V)

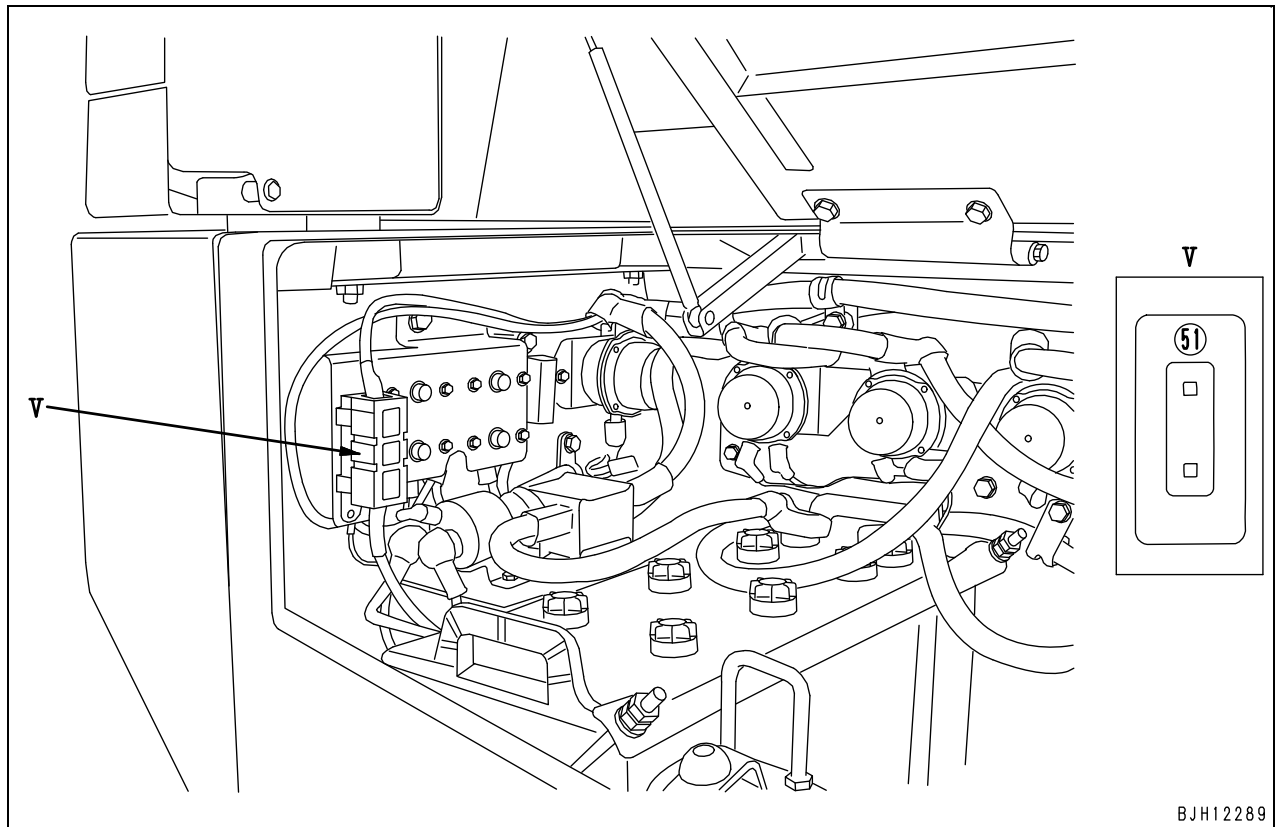

Type of power supply	Fuse No.	Fuse capacity	Destination of power
Accessory power supply	V	300 A	Intake air heater

## E-4 When starting switch is turned OFF, machine monitor cannot be operated

Trouble	When starting switch is turned OFF and switches are operated, service meter & integrated odometer, turn signal pilot lamp, and headlamp high beam pilot lamp on machine monitor are not turned ON or OFF.
Related information	

Possible causes and standard value in normal state	Causes		Standard value in normal state/Remarks on troubleshooting			
	Possible causes and standard value in normal state	1	Trip of circuit breaker (30 A)	If circuit breaker is broken, circuit probably has ground fault. (See cause 4.)		
2		Breakage of fuse (BT2-No. 18)	If fuse is broken, circuit probably has ground fault. (See cause 4.)			
3		Disconnection in wiring harness (Disconnection in wiring or defective contact in connector)	★ Prepare with starting switch OFF, then carry out troubleshooting without turning starting switch ON.			
			Wiring harness between terminal battery (-) – chassis ground (ER)	Resistance	Max. 1 Ω	
			Wiring harness between battery (+) – junction block – battery relay (66) – circuit breaker (82)	Resistance	Max. 1 Ω	
			Wiring harness between circuit breaker (84) – BT2(15)	Resistance	Max. 1 Ω	
			Wiring harness between BT2(16) – DPC1 (female) (4), (5)	Resistance	Max. 1 Ω	
4		Ground fault in wiring harness (Short circuit with GND circuit)	★ Prepare with starting switch OFF, then carry out troubleshooting without turning starting switch ON.			
			Wiring harness between battery (+) – junction block – battery relay (66) – circuit breaker (82)	Resistance	Min. 1 MΩ	
			Wiring harness between circuit breaker (84) – BT2(15) or circuit branch end	Resistance	Min. 1 MΩ	
			Wiring harness between BT2(16) – DPC1 (female) (4), (5) or circuit branch end	Resistance	Min. 1 MΩ	
5		Defective machine monitor	★ Prepare with starting switch OFF, then carry out troubleshooting without turning starting switch ON.			
			DPC1	Voltage		
			Between (4), (5) and (9), (10)	20 - 30 V		

Circuit diagram related to AISS LOW switch

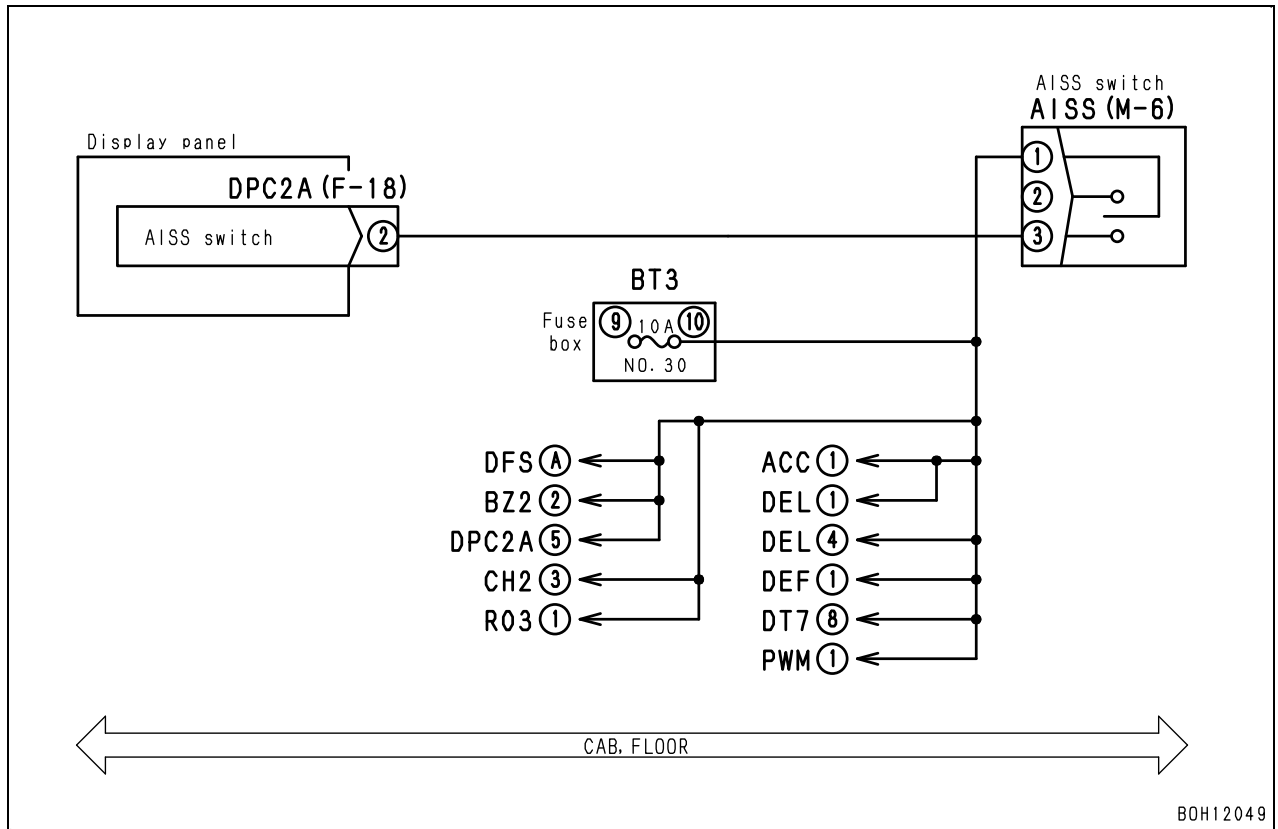

Trouble	(3)When turn signal lever and hazard lamp switch are operated, turn signal lamps on either of both sides do not blink (They blink normally when hazard switch is turned ON, however).
Related information	<ul style="list-style-type: none"> <li>Turn signal line is branched at switch and relay toward right, left, front, and rear. If only 1 lamp is defective, bulb may be broken or wiring harness on signal side or ground side may be defective.</li> </ul>

Possible causes and standard value in normal state	Causes		Standard value in normal state/Remarks on troubleshooting		
	Possible causes and standard value in normal state	1	Breakage of fuse (BT1-No. 2)	If fuse is broken, circuit probably has ground fault. (See cause 5.)	
2		Defective turn signal lever (Internal disconnection)	★ Prepare with starting switch OFF, then carry out troubleshooting without turning starting switch ON.		
			CM (male)	Turn signal lever	Resistance
			Between (6) – (7)	Neutral	Min. 1 MΩ
				Left	Max. 1 Ω
Between (6) – (8)		Neutral	Min. 1 MΩ		
		Right	Max. 1 Ω		
3		Defective hazard relay 2 (Internal defect)	★ Prepare with starting switch OFF, then turn starting switch ON and carry out troubleshooting.		R13
Replace hazard relay 2 (Right No.) with another relay. If turn signal lamp blinks at this time, hazard relay 2 is defective.					
4		Disconnection in wiring harness (Disconnection in wiring or defective contact in connector)	★ Prepare with starting switch OFF, then carry out troubleshooting without turning starting switch ON.		
			Wiring harness between BT1(4) – R13 (female) (6)	Resistance	Max. 1 Ω
			Wiring harness between CM (female) (6) – circuit branch end point	Resistance	Max. 1 Ω
5		Short circuit in wiring harness (Contact with GND circuit)	★ Prepare with starting switch OFF, then carry out troubleshooting without turning starting switch ON.		
			Wiring harness between BT1(4) – R13 (female) (6)	Resistance	Min. 1 MΩ
			Wiring harness between CM (female) (6) – FLS (female) (4) or R12 (female) (1)(3)	Resistance	Min. 1 MΩ

## E-15 Backup lamp and backup buzzer operate abnormally

Trouble	(1) When gearshift lever is set to R1 or R2, backup lamp and backup buzzer do not operate.
Related information	

Possible causes and standard value in normal state	Cause		Standard value in normal state/Remarks on troubleshooting		
	Possible causes and standard value in normal state	1	Breakage of fuse (BT1-No. 8)	If fuse is broken, circuit probably has ground fault. (See cause 4.)	
2		Defective backup lamp and backup buzzer relay (Internal defect)	★ Prepare with starting switch OFF, then turn starting switch ON and carry out troubleshooting.		
			Replace backup lamp and backup buzzer relay (Right No.) with another relay. If backup lamp and backup buzzer operate at this time, backup lamp and backup buzzer relay is defective.	R5	
3		Disconnection in wiring harness (Disconnection in wiring or defective contact in connector)	★ Prepare with starting switch OFF, then carry out troubleshooting without turning starting switch ON.		
			Wiring harness between R05 (female) (5)–circuit branch end point	Resistance	Max. 1 Ω
			Wiring harness between R05 (female) (6) – JCA – chassis ground (ER2)	Resistance	Max. 1 Ω
			Wiring harness between BT1(16) – R05 (female) (2), (4)	Resistance	Max. 1 Ω
4		Ground fault in wiring harness (Short circuit with GND circuit)	★ Prepare with starting switch OFF, then carry out troubleshooting without turning starting switch ON.		
			Wiring harness between R05 (female) (5)–circuit branch end point	Resistance	Min. 1 MΩ
			Wiring harness between BT1(16) – R05 (female) (2), (4)	Resistance	Min. 1 MΩ
			Wiring harness between CJK (female) (6) – chassis ground (94)	Resistance	Max. 1 Ω

Trouble	(2)When gearshift lever is set to R1, backup lamp and backup buzzer do not operate (They operate normally at R2, however).
Related information	

Possible causes and standard value in normal state	Cause		Standard value in normal state/Remarks on troubleshooting		
	Possible causes and standard value in normal state	1	Defective diode D06 (Internal disconnection)	★ Prepare with starting switch OFF, then carry out troubleshooting without turning starting switch ON.	
D06 (male)				Continuity	
Between (2) – (1)				There is continuity	
2		Disconnection in wiring harness (Disconnection in wiring or defective contact in connector)	★ Prepare with starting switch OFF, then carry out troubleshooting without turning starting switch ON.		
			Wiring harness between SF1 (female) (4) – D06 (female) (2)	Resistance	Max. 1 Ω
			Wiring harness between D06 (female) (1) – circuit branch end point	Resistance	Max. 1 Ω
3		Ground fault in wiring harness (Short circuit with GND circuit)	★ Prepare with starting switch OFF, then carry out troubleshooting without turning starting switch ON.		
			Wiring harness between SF1 (female) (4) – D06 (female) (2) or ATC2 (female) (25)	Resistance	Min. 1 MΩ

Trouble	(3) Air is not cooled (Cooling performance is insufficient)
Related information	

Possible causes and standard value in normal-state	Causes		Standard value in normal state/Remarks on troubleshooting		
		1	Defective diode	★ Prepare with starting switch OFF, then carry out troubleshooting without turning switch ON.	
Between (male) (2) (+) . (1) (.) of connector DIO				There is continuity	
Between (male) (1) (+) . (2) (.) of connector DIO				There is no continuity	
2		Defective air conditioner compressor	★ Prepare with starting switch OFF, then carry out troubleshooting without turning switch ON.		
			Between [17] on air conditioner compressor side of connector COMP . ground (Air conditioner compressor coil resistance)	Resistance	Approx. 15 Ω
			★ Prepare with starting switch OFF, then turn starting switch ON and carry out troubleshooting.		
			Between connector COMP (female) ([16]) (1) - ground	Voltage	20 – 30 V
3		Ground fault in wiring harness (Contact with GND circuit)	★ Prepare with starting switch OFF, then carry out troubleshooting without turning switch ON.		
			Between (2) - (9) of [12] on machine wiring harness side of connector AC1	Resistance	Min. 1 MΩ
			Between (2) of [11] on air conditioner wiring harness of connector AC1 - (9) of [12] on machine wiring harness side	Resistance	Min. 1 MΩ
			Between (11) of [11] on air conditioner wiring harness of connector AC1 - (9) of [12] on machine wiring harness side	Resistance	Min. 1 MΩ
			Between (11) - (9) of [12] on machine wiring harness side of connector AC1	Resistance	Min. 1 MΩ
			Between (2) of [15] on wiring harness side of connector ACRD - ground	Resistance	Min. 1 MΩ
4		Defective pressure switch	★ Prepare with starting switch OFF, then carry out troubleshooting without turning switch ON.		
			Between (1) . (2) on pressure switch side of connector ACRD	Resistance	Min. 1 Ω
5		Disconnection in wiring harness	★ Prepare with starting switch OFF, then turn starting switch ON and carry out troubleshooting.		
			Between (14) or (15) of connector [1] - ground (Air conditioner compressor coil resistance)	Resistance	Approx. 15 Ω
6		Defective control amplifier	★ Prepare with starting switch OFF, then turn starting switch ON and carry out troubleshooting.		
			Between connector CM (female) (1) - ground	Voltage	20 – 30 V

## Special tool list

- ★ Tools with part number 79\*T-\*\*\*-\*\*\*\* means that they are not available from Komatsu Ltd. (i.e. tools to be made locally).
- ★ Necessity
  - . . . . . Special tools that cannot be substituted and should always be used
  - . . . . . Special tools that will be useful if available and are substitutable with tools available on the market
- ★ New/Remodel:
  - N. . . . . Tools newly developed for this model. They have a new part number respectively.
  - R. . . . . Tools made available by redesigning the existing tools which were developed for other models. Each of them has a new part number assigned by setting forward the part number of the existing tool.
  - Blank. . . Tools already available for other models. They can be used without any modification.
- ★ Tools marked with ○ in the sketch column are presented in the sketches of the special tools (See "Sketches of special tools")

Component	Symbol	Part No.	Part name	Necessity	Q'ty	New/remodel	Sketch	Nature of work, remarks	
				■					
Removal and installation of fuel supply pump		1	795 - 630 - 5500	Standard puller	■	1			Removal of fuel supply pump
		2	01010 - 81090	Bolt	■	2			
		3	01643 - 31032	Washer	■	2			
Removal and installation of engine assembly		4	792-220-1110	Centering tool	■	2			Centering of engine assembly and transmission assembly
		5	01050-61225	Bolt	■	8			
Removal and installation of fuel injector and cylinder head		6	795-125-1210	Thickness gauge	■	1			Adjustment of clearance in crosshead
Removal and installation of cylinder head	A	7	790-331-1110	Angle tightening wrench	■	1			Angle tightening of cylinder head bolt
		8	795-931-1100	Seal puller	■	1			
Removal and installation of front oil seal and rear oil seal		9	795T-421-1210	Push tool	■	1	○	Removal front oil seal and rear oil seal	
			01050-31625	Bolt	■	4			
		01050-31645	Bolt	■	4				
		10	795T-421-1220	Push tool	■	1	○		
			01050-31625	Bolt	■	4			
		01050-31645	Bolt	■	4				
11	795-521-1110	Push tool	■	1					
	01050-31640	Bolt	■	4					
Disassembly, assembly of output shaft	1	B	790-201-2210	Plate	■	1		Press fitting of shaft bearing	
			790-201-2740	Spacer	■	1			
			791-600-1120	Bolt	■	1			
			790-101-2540	Washer	■	1			
			01580-01613	Nut	■	1			
			01643-31645	Washer	■	2			
			790 - 101 - 2102	Puller (294 kN {30 ton})	■	1			
	790 - 101 - 1102	Hydraulic pump	■	1					
	2			790-101-5401	Push tool kit	■	1		Press fitting of cage oil seal
				790-101-5431	● Plate		1		
				790-101-5421	● Grip		1		
				01010-51240	● Bolt		1		



# Articulated Dump Truck HM400-2

Machine model    Serial number  
HM400-2         2001 and up

---

## 50 Disassembly and assembly

### Power train, Part 1

---

Removal and installation of output shaft assembly-----	2
Disassembly and assembly of output shaft assembly-----	6
Removal and installation of transmission and front differential assembly-----	9
Disconnection and coupling of front differential and transmission-----	17
Disassembly and assembly of torque converter assembly-----	18
Disassembly and assembly of transmission assembly-----	26

2) Disconnect right rear brake hoses (9) and (10).

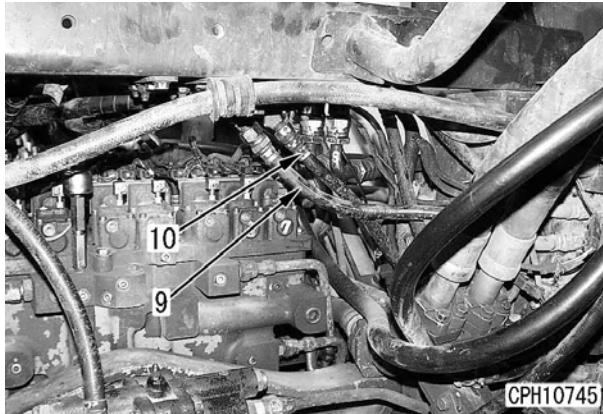

3) Disconnect left rear brake hoses (11) and (12).  
(Section above transmission)

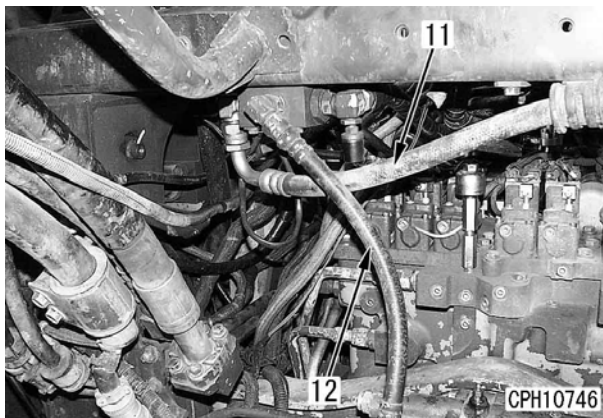

13. Vertical main bar  
Remove vertical main bar (13).  
⏏ Vertical main bar: 45 kg

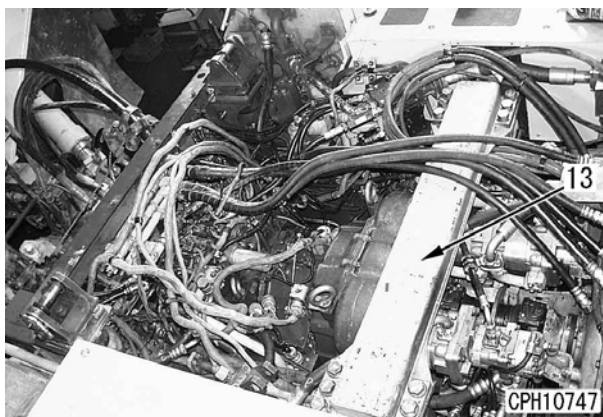

14. Frame and hose assembly  
Remove frame and hose assembly (14).

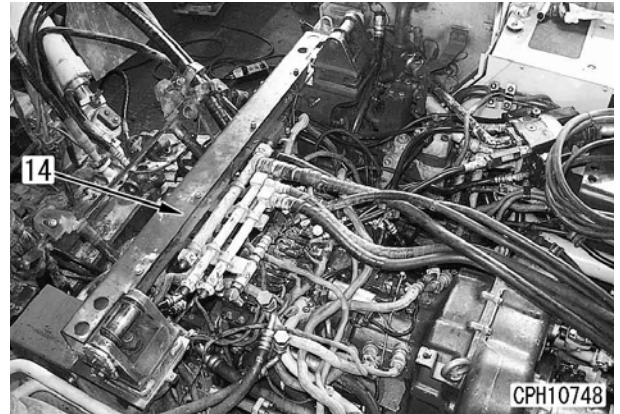

15. Centralized connectors between vehicle body and engine  
Remove top cover (15) and disconnect centralized connectors (16) and (17) between the vehicle body and engine.

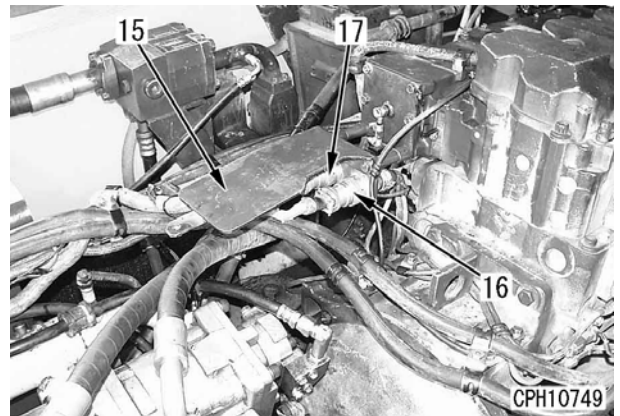

16. Steering pipes and hoses  
Disconnect steering hoses (18) – (22) and remove orifice (23).

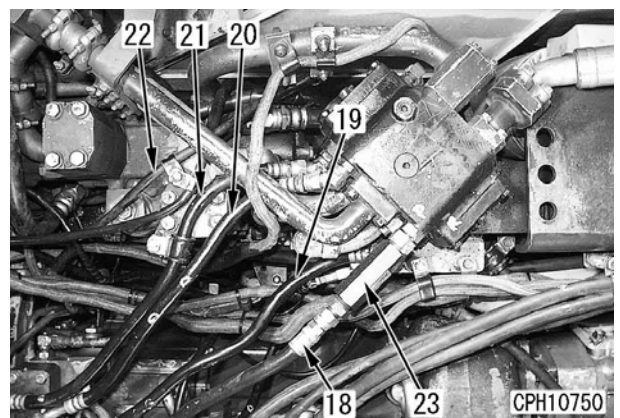

10) Remove disc (30) from case (29).

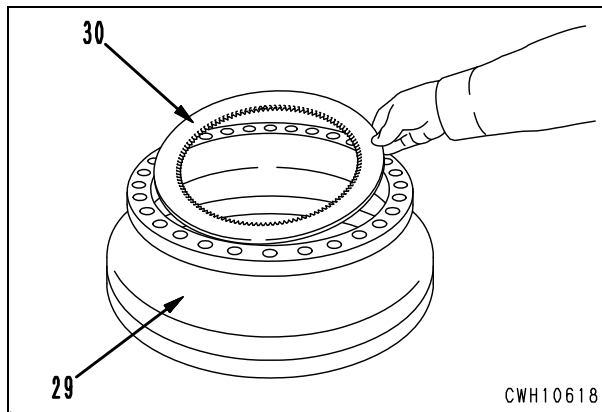

8. Disassembly of stator assembly

1) Remove the mounting bolts and stator (31) from race (32).

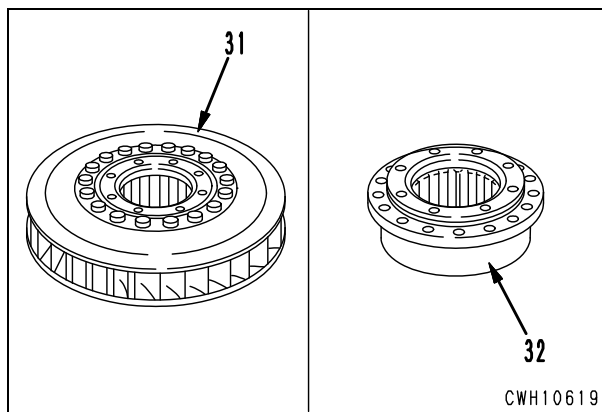

2) Remove bushings (33) and (34) from race (32).

3) Remove race (35) and free wheel (36) from race (32).

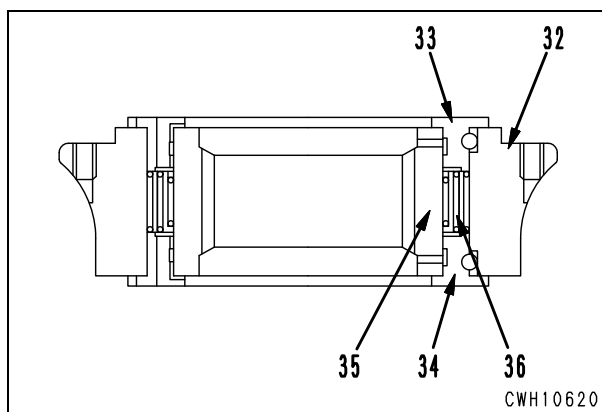

**Assembly**

1. Assembly of stator assembly

1) Install free wheel (36) and race (35) to race (32).

★ Install the free wheel with the arrow of the cage end on the input side.

★ Apply oil (TO30) to the sliding surfaces of the races.

2) Install bushings (34) and (33) to race (32).

★ Install the bushings by expansion fit.

★ Apply oil (TO30) to the sliding surfaces.

★ Put in the ball without fail.

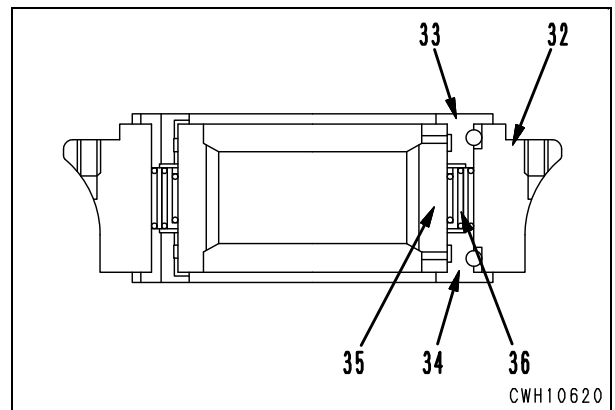

3) Install stator (31) to race (32).

Mounting bolt: Adhesive (LT-2)

Mounting bolt:

58.8 – 73.5 Nm {6 – 7.5 kgm}

★ Check the rotating direction of the stator. (View from input side)

Clockwise: Free

Counterclockwise: Locked

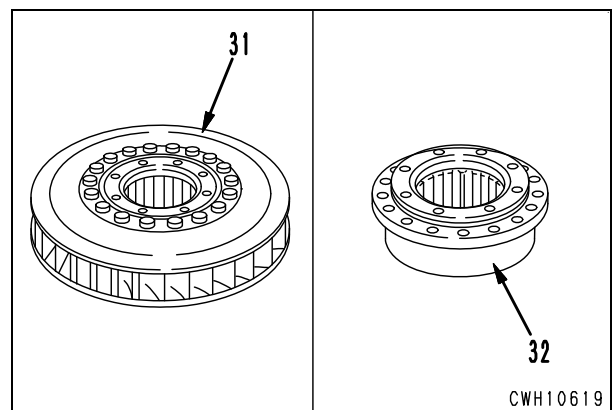

- 3] Remove snap rings (36) and (68) from shaft (35).  
 ★ Snap ring (68) is for the oil sump.

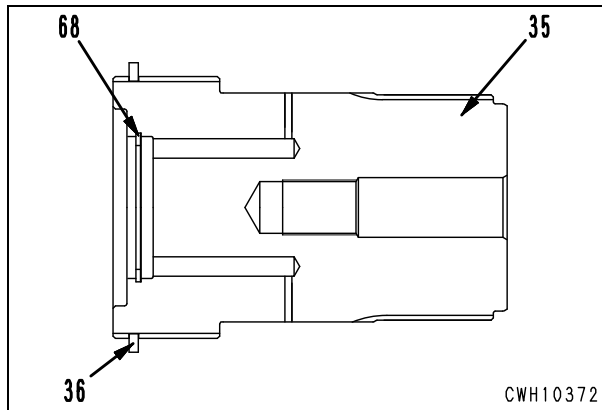

- 4] Remove gear (37), bearing (34) [Outer races (34-1b), (34-2b)], and bearing inner race (38a).

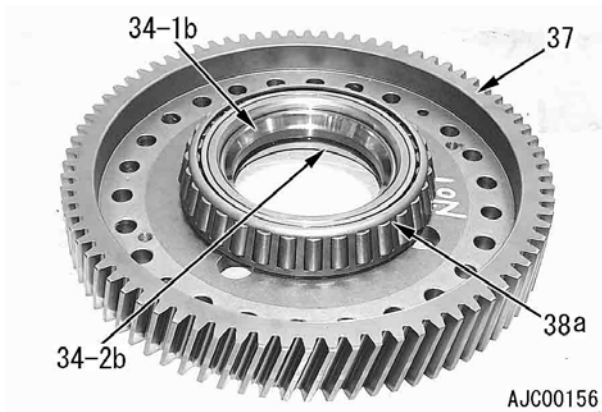

- 3] Remove snap ring (39) and sun gear (40).

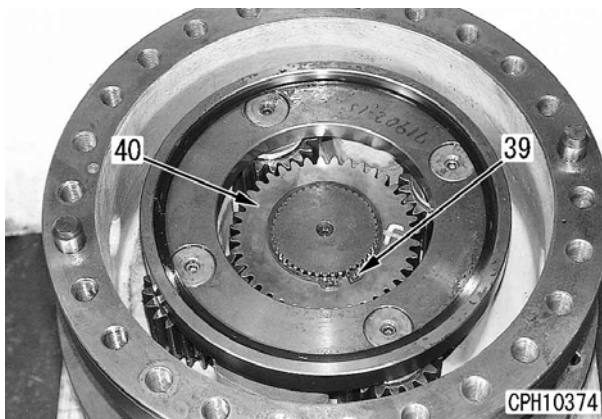

- 4] Remove snap ring (41).

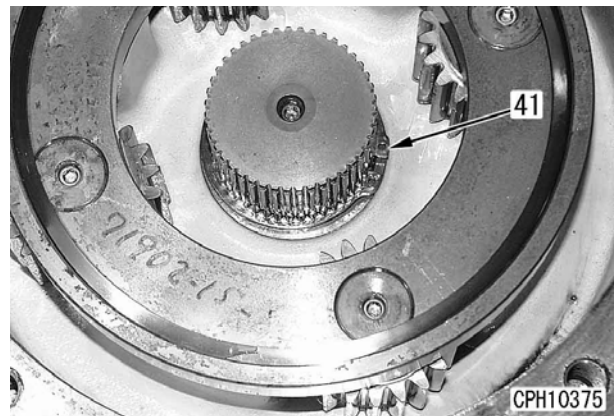

- 5] Remove the mounting bolts 12 pieces and carrier assembly (42).

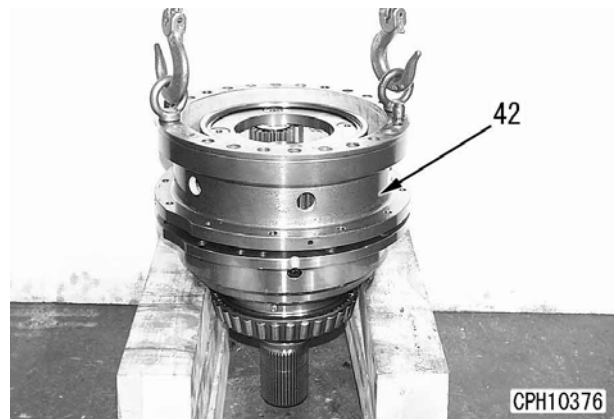

- 6] Disassemble the carrier assembly according to the following procedure.

- 1] Remove ring (43).
- 2] Drive out shaft (44) toward ball (45) and remove shaft (44), gear (46), ball (45), bearing (47) 2 pieces, and thrust washers (48) 2 pieces.

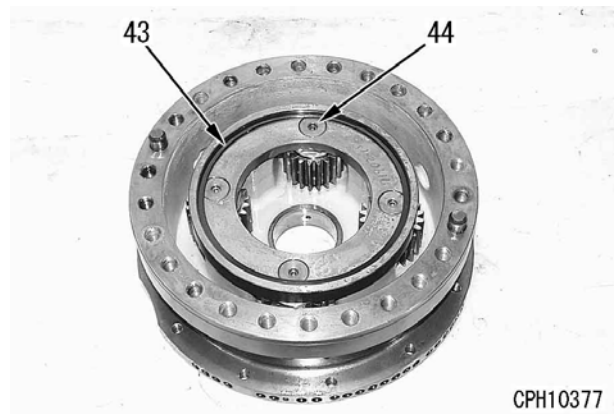



5) Remove end plate (169), plates (170) 12 pieces, discs (171) 11 pieces, and wave springs (172) 11 pieces from the R clutch.



7) Remove seal rings (176) and (177) from piston (175).

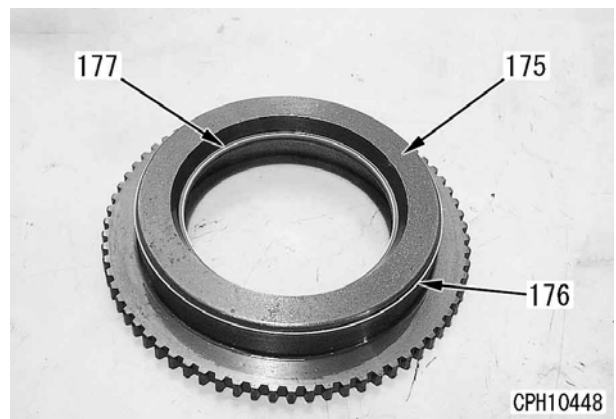
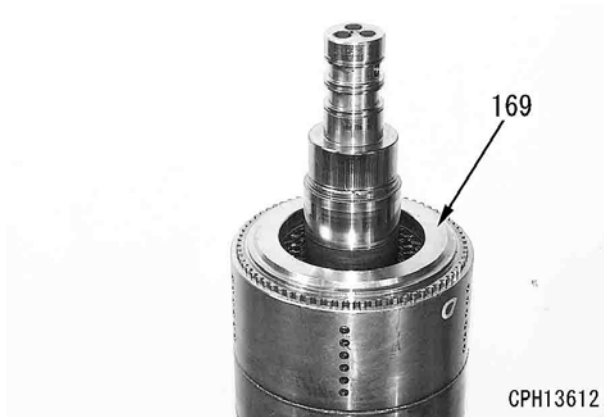

(FL clutch side)

8) Using push puller [4], remove gear (178) and bearing inner race (179a) together.

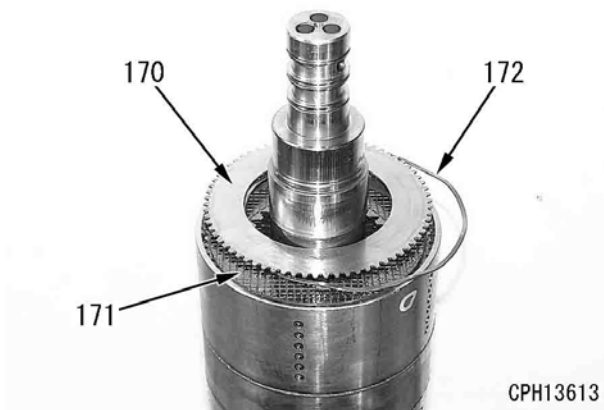

6) Remove thrust washer (173) and piston assembly (174).

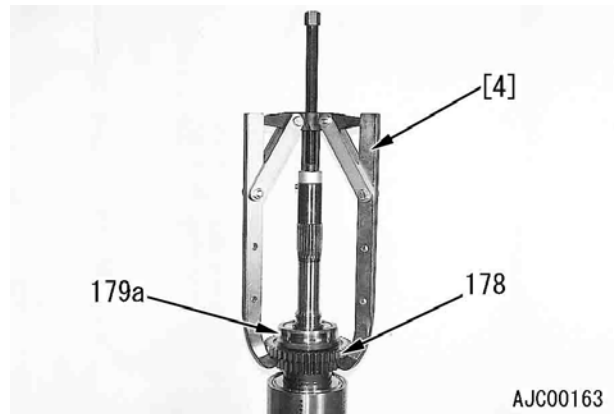

9) Remove spacer (180) 2 piece type and thrust washer (181), then remove gear and needle roller bearing (182) assembly.

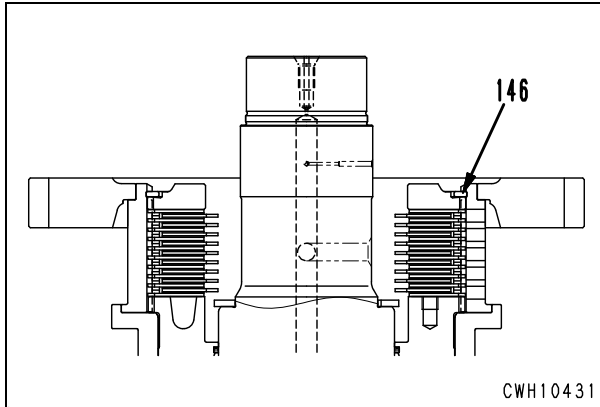

- 8) Install gear and needle roller bearing assembly (140), thrust washer (143), and spacer (142).
- ★ If the gear and needle roller bearing assembly (140) is difficult to install, repeat the procedure from step 5).

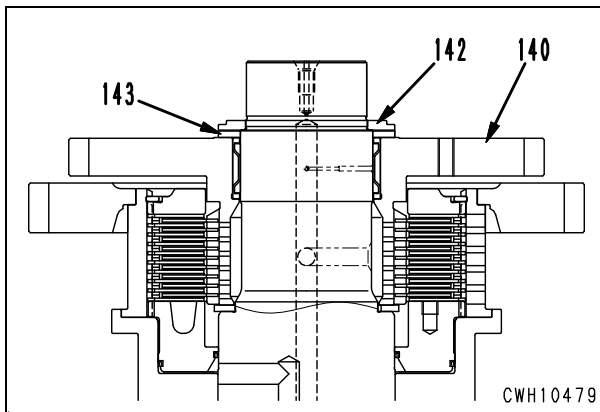

- 9) Install bearing inner race (141a) by shrink fit.
- ★ Shrink fit temperature: Approx. 120 °C for 30 minutes
  - ★ For bearing outer race (141b), see "Disassembly of transmission case assembly on opposite side of torque converter".



(1st clutch side)

- 10) Install seal rings (138) and (139) to piston (137).
- ★ Install the seal rings with the pressure receiving side directed to the housing.

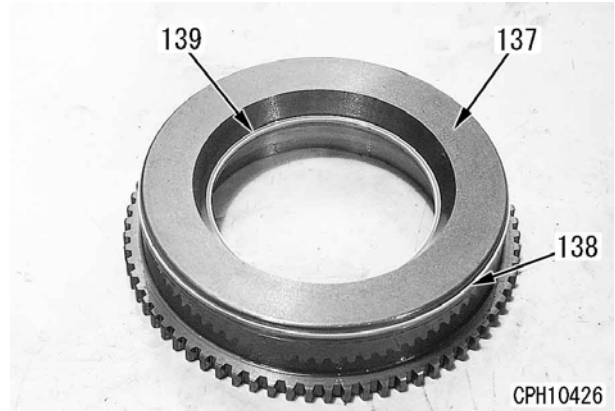

- 11) Install piston assembly (136) and thrust washer (134).
- ★ Using the hanging tap, install piston assembly (136), taking extreme care that the seal rings will not be caught.
  - 🔧 Apply oil (T030) to the periphery and contact surfaces of the seal rings.

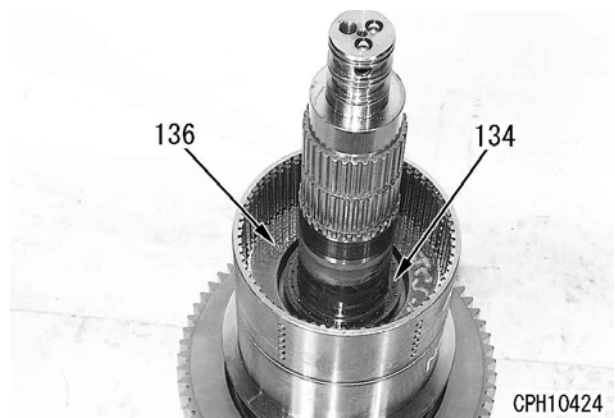
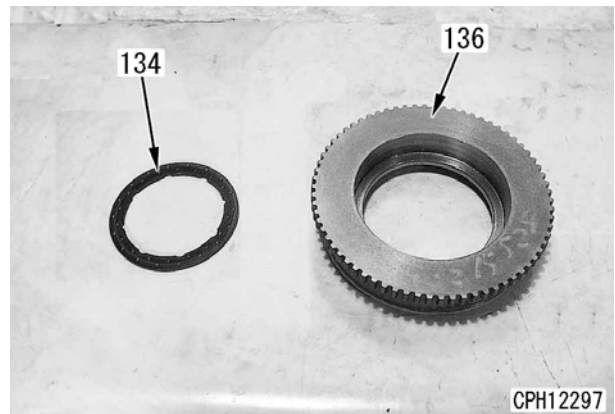

- 12) Install plates (131) 12 pieces, discs (132) 11 pieces, wave springs (133) 11 pieces, and end plate (130) to the 1st clutch.
- ★ Dip the discs in clean oil (T030) for at least 2 minutes before installing.

CLICK HERE TO **DOWNLOAD** THE COMPLETE MANUAL

- Thank you very much for reading the preview of the manual.
- You can download the complete manual from: [www.heydownloads.com](http://www.heydownloads.com) by clicking the link below



- Please note: If there is no response to CLICKING the link, please download this PDF first and then click on it.

CLICK HERE TO **DOWNLOAD** THE COMPLETE MANUAL