

Shop Manual

HD785-5LC

DUMP TRUCK

SERIAL NUMBERS **A10316 & UP**

KOMATSU[®]

CLICK HERE TO **DOWNLOAD** THE COMPLETE MANUAL

- Thank you very much for reading the preview of the manual.
- You can download the complete manual from: www.heydownloads.com by clicking the link below



- Please note: If there is no response to CLICKING the link, please download this PDF first and then click on it.

CLICK HERE TO **DOWNLOAD** THE COMPLETE MANUAL

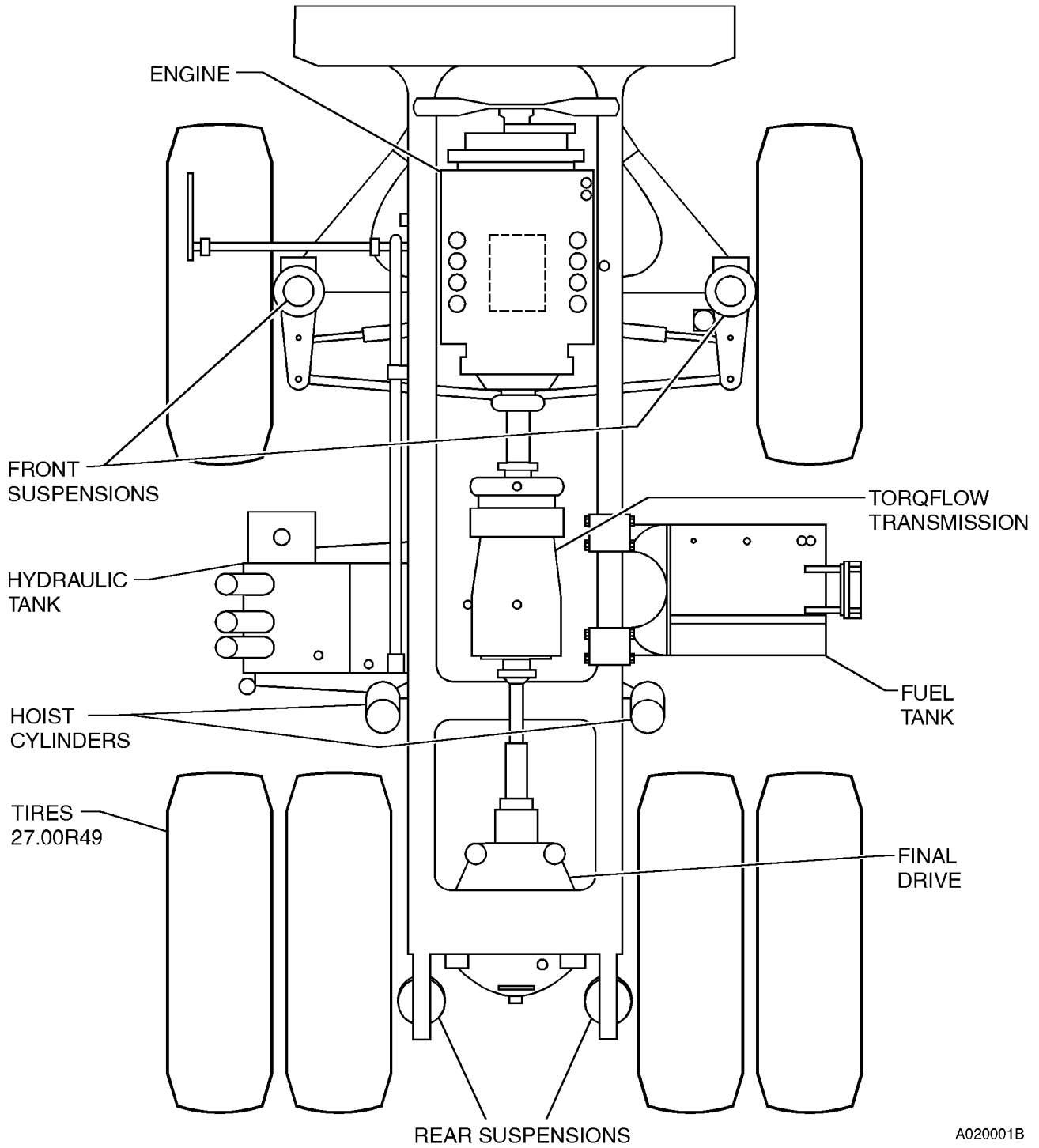

A020001B

HD785 MAJOR COMPONENTS

- Report immediately to supervisor any conditions on haul road, pit or dump area that may cause an operating hazard.
- Check for flat tires periodically during shift. If truck has been run on a “flat”, **it must not be parked in a building until the tire cools**. If tire must be changed, do not stand in front of rim and locking ring when inflating tire mounted on the machine. Observers should not be permitted in the area and should be kept away from the side of such tires.



Tire and rim assembly may explode if subjected to excessive heat. Personnel should move to a remote or protected location if sensing excessively hot brakes, smell of burning rubber or evidence of fire near tire and wheel area.

If the truck must be approached, such as to fight a fire, those personnel should do so only while facing the tread area of the tire (front or back), unless protected by use of large heavy equipment as a shield. Stay at least 50 ft. (15 m) from the tread of the tire.

In the event of fire in the tire and wheel area (including brake fires), stay away from the truck at least 8 hours or until the tire and wheel are cool.

- Keep serviceable fire fighting equipment at hand. Report used extinguishers for replacement or refilling.
- Always have parking brake applied when the truck is parked and unattended. **DO NOT** leave truck unattended while engine is running.
- When parking, park a safe distance from other vehicles as determined by supervisor.
- Stay alert at all times! In the event of an emergency, be prepared to react quickly and avoid accidents. If an emergency arises, know where to get prompt assistance.

Check When Traveling In Reverse

Before operating the machine or work equipment, do as follows:

- Sound the horn to warn people in the area. For machines equipped with a back-up alarm, check that the alarm works properly.
- Check that there is no one near the machine. Be particularly careful to check behind the machine.
- If necessary, designate a person to check the safety. This is particularly necessary when traveling in reverse.
- When operating in areas that may be hazardous or have poor visibility, designate a person to direct work site traffic.
- Do not allow any one to enter the line of travel of the machine. This rule must be strictly observed even on machines equipped with a back-up alarm or rear view mirror.

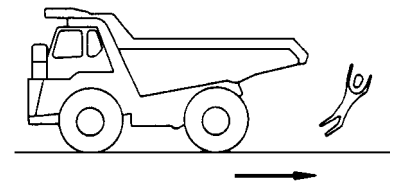

Traveling

- When traveling on rough ground, travel at low speed. When changing direction, avoid turning suddenly.
- Lower the dump body and set the dump lever to the FLOAT position when traveling.
- If the engine should stop when the machine is traveling, the emergency steering system will be activated. Apply the brakes immediately and stop the machine as quickly and safely as possible, and off the haul road, if possible.

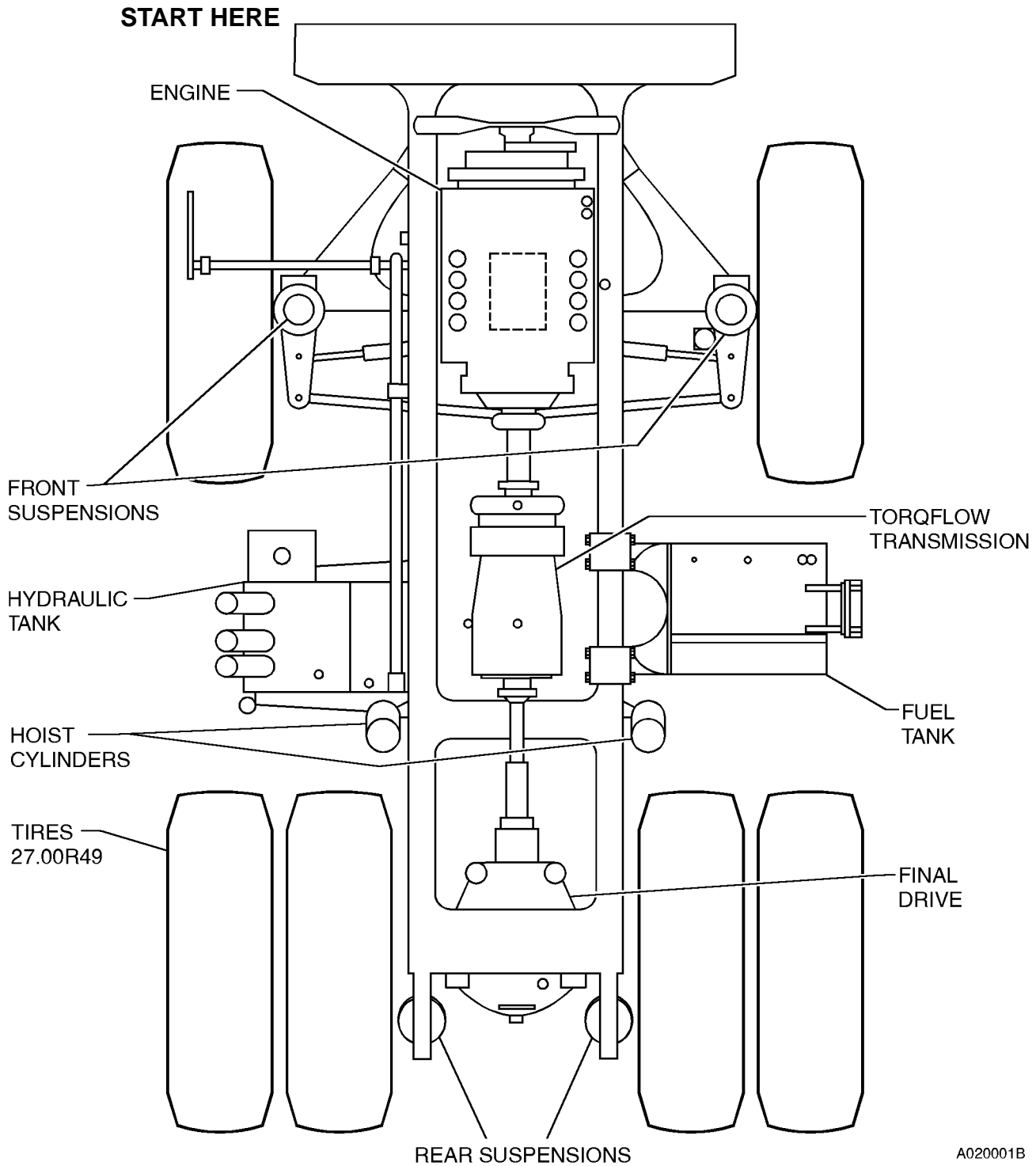

A020001B

HD785-5 “WALK-AROUND” INSPECTION

NOTE: Engine oil and transmission oil levels are checked most accurately when engine is running and all systems are at normal operating temperatures.

Refer to section P, Lubrication & Service, 10 Hour (Daily) Inspection for these procedures.

TOWING

Prior to towing a truck, many factors must be carefully considered. Serious personal injury and/or significant property damage may result if important safety practices, procedures and preparation for moving heavy equipment are not observed.

CAUTION

Both right and left planetary sun gears/drive axles should be removed before any towing. Refer to Section G in the Service Manual for these instructions. Extensive secondary damage can occur to final drive components and/or transmission, if truck is towed without first removing sun gears/drive axles.

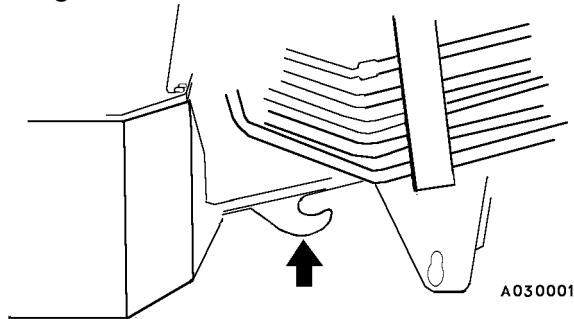

The truck must not be towed except in emergencies.

When towing becomes necessary, use the tow hook installed under the front frame and take the following precautions:

1. Block disabled truck to prevent movement while attaching tow bar.
2. If the engine is operable; keep the engine running while towing the machine, so that the steering and braking can be used.

If there is a failure in the air circuit, the brakes cannot be used, so be extremely careful when towing. When air pressure in air reservoir abnormally drops due to leakage from air circuit, parking brake and emergency brake are actuated. When towing truck, both brakes must be released. Refer to Brake Release following these Towing instructions.

If the engine is NOT operable, it is possible to steer using the emergency steering, but do not use it for more than 90 seconds, and travel at a speed of **less than** 5 km/h (3 mph).

3. If the truck loaded, dump the entire load. Never pull or tow a loaded truck.
4. If the engine is NOT operable, never haul the truck over 800m (2,625 ft.).

If the towing distance surpasses that limit, be sure to remove the drive shaft between the transmission and the differential case (if final drive sun gears have not been removed).

The towing speed must not be greater than 8 km/h (5 mph).

5. Inspect tow bar for capacity (it should be strong enough to tow 1.5 times the gross vehicle weight of truck being towed).
6. Determine that towing vehicle has adequate capacity to *both move and stop* the towed truck under all conditions.
7. Protect both operators in the event of tow bar failure.
8. Release disabled truck brakes and remove all blocking.

CAUTION

Do not tow the truck any faster than 8 kph (5 MPH).

9. Sudden movement may cause tow bar failure. Smooth and gradual truck movement is preferred.
10. Minimize tow angle at all times - NEVER EXCEED 30°. The towed truck must be steered in the direction of the tow bar.

The lubrication chart is located on the left hand front fender behind the ladder. Refer to Section P, Lubrication and Service, for more complete lubrication instructions.

LUBRICATION CHART

		LUBRICATION SPECIFICATION								
		-54°C TO -32°C	-32°C TO 0°C	0°C TO +32°C	ABOVE 32°C	ABOVE 40°C				
LUBE KEY	TYPE LUBRICANT	-65°F TO -25°F	-25°F TO 32°F	32°F TO 90°F	ABOVE 90°F	ABOVE 105°F				
A	ENGINE OIL	SEE ENG MAN*	SEE ENG MAN*	SEE ENG MAN*	SEE ENG MAN*	SEE ENG MAN*				
B	HYDRAULIC OIL	TO30/SAE 30	TO30/SAE 30	TO30/SAE 30	TO30/SAE 30	TO50/SAE 50				
C	HYDRAULIC OIL	TO10/SAE 10W*	TO10/SAE 10W*	TO10/SAE 10W	TO10/SAE 10W					
D	MOLYDISULPHIDE LUBE	#0	#1	#2	#2					
E	HYDRAULIC OIL	SEE SERVICE MAN.	SEE SERVICE MAN.	SEE SERVICE MAN.	SEE SERVICE MAN.					
F	HYDRAULIC OIL	TO10/SAE 10W*	TO10/SAE 10W*	TO30/SAE 30	TO30/SAE 30					
DESCRIPTION	SYM	PTS	L KEY	10HR	50 HR	100HR	250 HR	500 HR	1000 HR	2000 HR
ENGINE LUBE FILTER	1	4	A				SEE ENG MANUAL			
FUEL FILTER ELEMENT	2	2					SEE ENG MANUAL			
FRONT SUSP ASSY/PINS	3	8	D				GREASE			
STEERING CYL LINKAGE	4	4	D				GREASE			
STEERING LINKAGE	5	5	D				GREASE			
HYDRAULIC FILTER	6	3							CHANGE	
HYD. TANK (HOIST/STRG)	7	1	C	CHECK						CHANGE
HOIST CYLINDER PIVOT	8	4	D				GREASE			
U-JOINT ASSY (REAR)	9	3	D				GREASE			
FINAL DRIVE CASE	10	2					CHECK			CHANGE
AXLE SUPPORT PIN	11	8	D				GREASE			
REAR SUSPENSION PIN	12	4	D				GREASE			
DIFFERENTIAL CASE	13	1					CHECK			CHANGE
BODY HINGE PINS	14	2	D				GREASE			
CORROSION RESISTOR	15	2						CHANGE		
ENGINE CRANKCASE OIL	16	1	A	CHECK				CHANGE		
TRANS OIL FILTER	17	1						CHANGE		
FRONT BRAKE OIL TANK	18	1		CHECK						
U-JOINT ASSY (FRONT)	19	2	D				GREASE			
TRANSMISSION MOUNT	20	1	D					GREASE		
TRANSMISSION OIL	21	1	F	CHECK					CHANGE	
TRANS CASE BREATHER	22	2					CLEAN			
HYD TANK BREATHER ELE.	23	1					CHANGE			
DIFF CASE BREATHER	24	1					CLEAN			
ENGINE BY-PASS FILTER	25	2						CHANGE		
PARKING BRAKE	26	6	D						GREASE	
DUMP CONTROL LINKAGE	27	3	D							GREASE
ENG FRONT TRUNNION	28	1	D							GREASE
HYD TANK BRAKES	29	1	E	CHECK						CHANGE
TRANS. STRAINER	30	2							CLEAN	
HI PRESS HYD FILTER ELEMENT	31	2								CHANGE
AIR DRYER DESICCANT CART.	32	2							CHANGE	

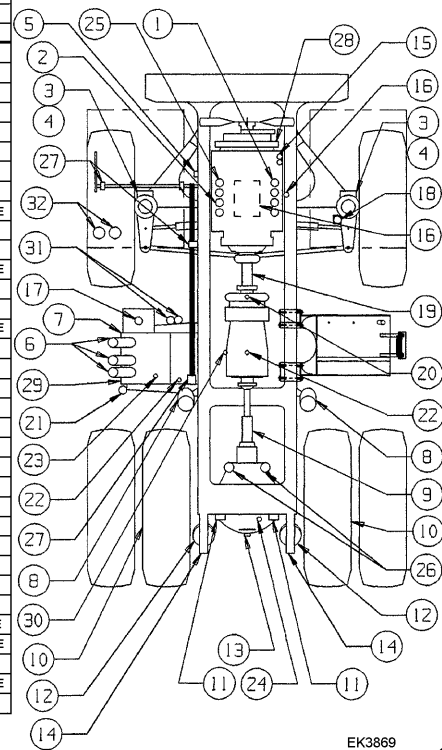

*AUXILIARY HEATERS REQUIRED BELOW -23°C (-10°F)

EK3869

CHASSIS STANDARD VALUES (Continued)					
	ITEM	MEASUREMENT CONDITIONS	UNIT	STANDARD VALUE	PERMISSIBLE VALUE
BRAKES					
Service brake braking distance	91 ton payload	<ul style="list-style-type: none"> Initial speed: 32 km/h (20 MPH) Distance from starting speed to stop Max. actuating air pressure: 8.3 kg/cm² (120 psi) Max. hydraulic pressure: Rear: 45 kg/cm² (640 psi) Front: 187 kg/cm² (2660 psi) On flat, dry road surface 	m (ft)	Max. 29 (95)	Max. 29 (95)
	Empty			Max. 22.3 (73)	Max. 22.3 (73)
Retarder brake braking distance	91 ton payload			Max. 29 (95)	Max. 38 (125)
	Empty			Max. 22.3 (73)	Max. 30 (98)
Brake actuating pressure	Front chamber		Min. 160 (2275)	Min. 160 (2275)	
	Rear chamber (service)		Min. 45 (640)	Min. 45 (640)	
	Rear chamber (retarder)	Min. 45 (640)	Min. 45 (640)		
Stopping distance when emergency brake is applied		<ul style="list-style-type: none"> Carrying 91 ton payload Initial speed: 32 km/h (20 mph) On flat, dry road surface 	m (ft)	Max. 60.9 (200)	Max. 60.9 (200)
PARKING BRAKE					
Braking Capacity (sin θ)		<ul style="list-style-type: none"> With 91 ton payload After adjusting clearance between disc and pad 	%	Min. 15	Min. 15
Starting Test		<ul style="list-style-type: none"> F2 Torque converter stall 	rpm	Min. 2070	Min. 2070
HOIST LEVER					
Operating Force	HOLD ⇒ RAISE	Center of control lever knob	kg (lbs.)	Max. 10 (22)	Max. 10 (22)
	RAISE ⇒ HOLD			Automatically reset	Automatically reset
	HOLD ⇒ FLOAT			5 - 10 (11 - 22)	5 - 10 (11 - 22)
	FLOAT ⇒ HOLD			3 - 6 (7- 13)	3 - 6 (7- 13)
	LOWER ⇒ FLOAT			Automatically reset	Automatically reset
	FLOAT ⇒ LOWER			Max. 13 (29)	Max. 13 (29)
Travel	RAISE ⇒ HOLD (A)	(Refer to Figure 6-1 for hoist lever positions "A", "B", and "C")	mm (in.)	15 ± 2 (0.6 ± 0.07)	15 ± 2 (0.6 ± 0.07)
	HOLD ⇒ FLOAT (B)			11 ± 2 (0.4 ± 0.07)	11 ± 2 (0.4 ± 0.07)
	FLOAT ⇒ LOWER (C)			11 ± 2 (0.4 ± 0.07)	11 ± 2 (0.4 ± 0.07)
HOIST VALVE					
Relief Pressure	Engine @ High Idle	<ul style="list-style-type: none"> Oil temp.: 50° - 80°C (122° - 176°F) Engine: Full throttle Measure at end of stroke when raising body 	kg/cm ² (psi)	200 ^{+15 / - 0.0} (2845 ^{+210 / - 0.0})	200 ^{+15 / - 0.0} (2845 ^{+210 / - 0.0})
	Engine @ Low Idle			185 ^{+10 / - 0.0} (2630 ^{+142 / - 0.0})	185 ^{+10 / - 0.0} (2630 ^{+142 / - 0.0})

NOTES

ROCK EJECTORS

Rock ejectors are placed between the rear dual wheels to keep rocks or other material from lodging between the dual tires. Failure to keep ejectors in working order could allow debris to build up between the dual wheels and cause damage to the tires. The rock ejectors can be pinned up out of the way if desired.

Inspection

1. The ejectors must be positioned on the center line between the rear tires within 0.25 in. (6.35 mm).
2. With the truck parked on a level surface, the arm structure should be approximately 4.88 in. (124 mm) away from the wheel spacer ring.

NOTE: With Rock Ejector Arm (2, Figure 3-7) hanging vertical, there must be NO GAP at stop on bracket (4).

3. If the arm (2) becomes bent, it must be removed and straightened.
4. The wear plates must be replaced if severely worn.
5. Inspect the mounting brackets, pins (1) and stops at each shift change for wear and/or damage, and repair as necessary.

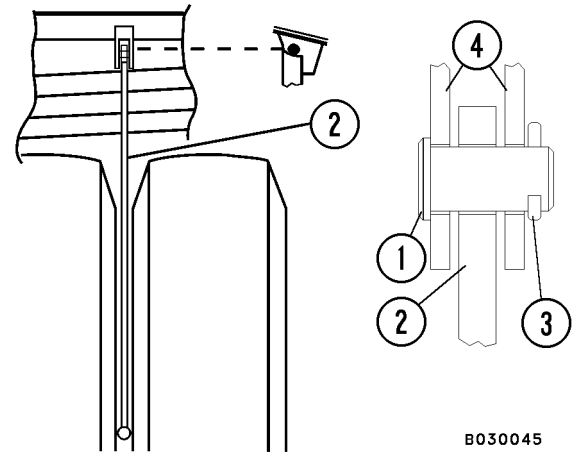

FIGURE 3-7. ROCK EJECTOR

- | | |
|---------------------|-------------------------|
| 1. Pin Structure | 3. Cotter Pin |
| 2. Rock Ejector Arm | 4. Rock Ejector Bracket |

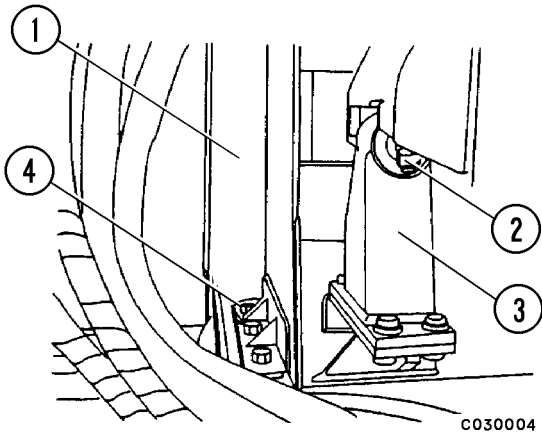

FIGURE 3-3. RADIATOR HOOD

- | | |
|------------------|---------------------|
| 1. Radiator Hood | 3. Radiator Support |
| 2. Damper | 4. Capscrews |

6. Remove hood according to Removal instructions in Section B.
7. Disconnect headlight wire (1, Figure 3-2) and air horn hoses (2) on the left side of the radiator.
8. Remove the plugs, capscrews, and nuts from across the top of the radiator hood that secures it to the cross brace below.

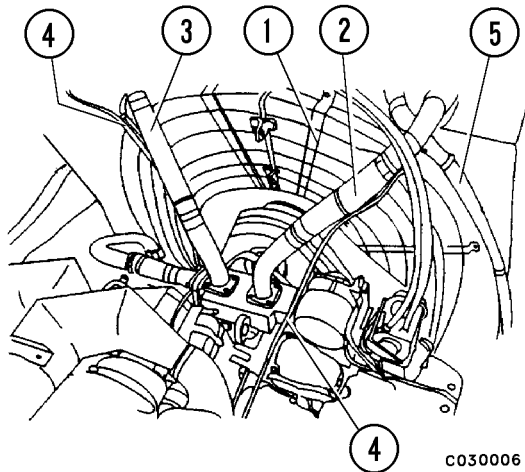

FIGURE 3-4. RADIATOR COMPONENTS

- | | |
|---------------------------|---------------------|
| 1. Fan Guard | 4. De-Aeration Hose |
| 2. Thermostat Outlet Hose | 5. Bypass Hose |
| 3. Thermostat Outlet Hose | |

9. Remove six (6) mounting capscrews (4, Figure 3-3) at the base of the radiator hood and remove. Tag the shims for proper placement during assembly.
10. Remove fan guard (1, Figure 3-4).
11. Remove thermostat outlet hoses (2 & 3).
12. Disconnect de-aeration hoses (4).
13. Disconnect hose at radiator cap neck (routed to coolant reservoir). Remove clamps attaching hose to radiator. Disconnect coolant level sensor.
14. Remove radiator outlet hose (2, Figure 3-5) and radiator bypass hose (1).
15. Remove connector hoses and tubes between air to air coolers (5) and engine.
16. Remove transmission oil cooler hoses (3). Remove oil cooler inlet hose and tube (4).



Radiator assembly weighs approximately 585 kg (1290 lbs.) Use adequate lifting device.

17. Attach a sling or hoist to the radiator and take up the slack. Remove radiator top mounting rod by removing nuts (1, Figure 3-6).
18. Remove radiator bottom mount capscrews (4) and remove radiator. Move radiator to a clean work area for service.

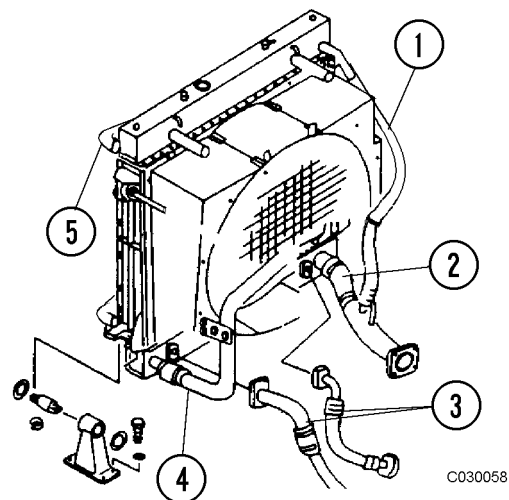

FIGURE 3-5. COOLANT AND OIL LINES

- | | |
|---------------------------|--------------------------|
| 1. Bypass Hose | 4. Oil Cooler Inlet Line |
| 2. Outlet Hose | 5. Air to Air Cooler |
| 3. Transmission Oil Hoses | |

9. If equipped with optional exhaust brake, install brake valves on mounting brackets and connect air lines at port on top of valves. (If exhaust brake valves have been removed for service, valves must be correctly positioned with the arrow (on side of valve body) pointed away from the turbocharger and toward the exhaust pipe. Refer to Section M for additional information.) Install exhaust pipes.
10. Install all coolant pipes and hoses. Install heater hoses. (Refer to *Cooling System* for final hose hookup after radiator is installed.)
11. Connect fuel supply and return hoses, fuel shut-off valve wiring. Connect air compressor lines.
12. With wiring harnesses positioned on engine, connect engine speed sensor (2, Figure 4-5), engine coolant temperature sensor (3). Install hoses and connect wiring as necessary for any optional equipment (fan clutch, coolant heaters).
13. Connect starter motor battery circuit cables (3, Figure 4-3) and ground cable from starter(s) to engine mount bracket. Connect oil pressure switches (4).
14. Connect alternator output wire (4, Figure 4-2), ground (2), air conditioner compressor clutch,

and heater relays behind filters on right and left sides of engine (see Figure 4-1).

15. Install cover (11, Figure 4-9).
16. If equipped with optional battery disconnect switch, close switch to restore battery power. If disconnect is not installed, connect the negative, then the positive battery cables.
17. Refer to Cooling System, Radiator Installation in this section and install the radiator and coolant lines. Install grille according to procedure in Section B.
18. Open the fuel supply valve.
19. Recheck engine to be assured all air, oil, electric, and fuel lines have been reconnected to the proper locations, that all connections are secure, and all hoses and wiring clamps are installed in their original positions.

NOTE: Refer to Section P, Lubrication and Service for the proper fluids.

20. Fill engine oil to the specified level. Refill radiator with coolant to the specified level and run the engine to circulate the oil and coolant through the system until temperatures are stabilized. Then check fluid levels again. Check for oil, fuel or coolant leakage.

FIGURE 4-9. INTAKE PIPING

1. Air Cleaner Assembly
2. Clamps
3. Elbow
4. Air Cleaner Cap (Standard)
5. Warm Air Intake (Optional)
6. Center Deck Structure
7. Intake Duct
8. Turbocharger
9. Support Bracket
10. Hump Hose
11. Cover
12. Dump Body

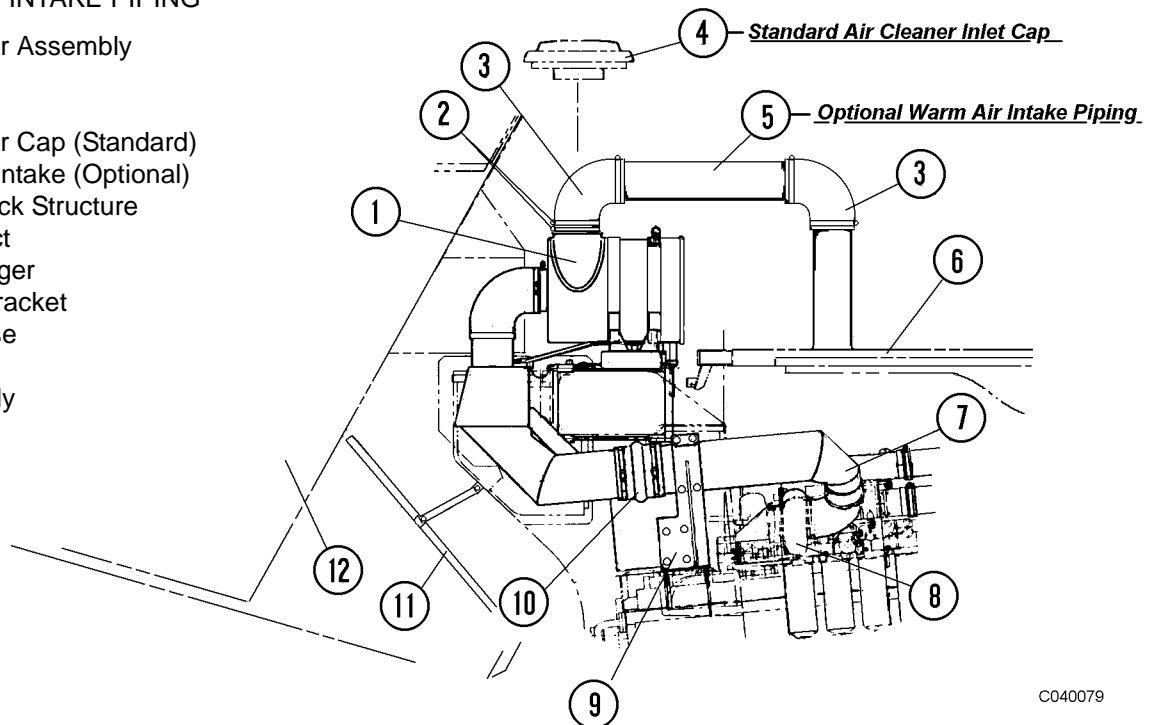

C040079

- c. Move air flow up and down vertically with pleats in filter material while slowly rotating filter element.
- d. When cleaning is complete, inspect filter element as shown in Figure 5-2 and if holes or ruptures are noted, replace the element with a new item.

Air Intake Troubleshooting

To insure maximum engine protection, be sure that all connections between air cleaner and engine intake are tight and positively sealed. If air leaks are suspected, check the following:

1. All intake lines, tubes and hump hoses for breaks, cracks, holes, etc., which could allow an intake air leak.
2. Check all air cleaner gaskets for positive sealing.
3. Check air cleaner elements, main and safety, for ruptures, holes or cracks.
4. Check air cleaner assembly for structural damage, cracks, breaks or other defects which could allow air leakage. Check all mounting hardware for tightness.

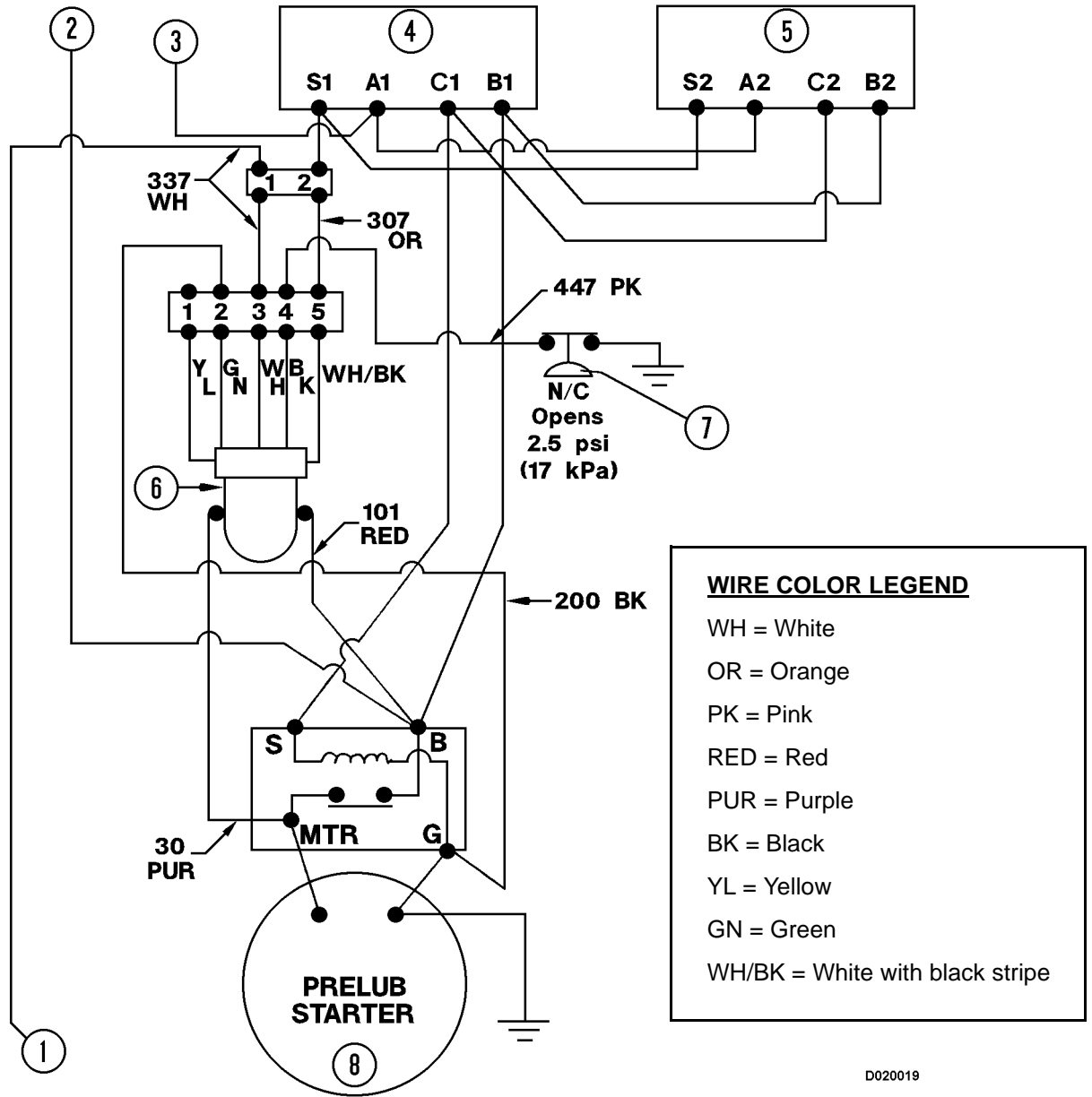

D020019

FIGURE 2-3. PRELUB SYSTEM ELECTRICAL DIAGRAM

- 1. Key Switch
- 2. 24VDC Battery (+)
- 3. Alternator Supply









- 4. Starter Safety Relay # 1
- 5. Starter Safety Relay # 2
- 6. Timer Solenoid

- 7. Prelub Oil Pressure Switch
- 8. Prelub Starter

MONITOR PANEL DISPLAYS

Figures 3-8 through 3-11 list the various monitor panel gauges, pilot lamps, caution lamps etc.. Each function is listed in its display category and shows the symbol (when applicable) that appears on the display area.

In addition, each function lists the conditions under which the display is ON or OFF and any additional warnings such as the central warning lamp or buzzer.

CATEGORY	SYMBOL	DESCRIPTION	DISPLAY CONDITIONS
CAUTION		Air Pressure On below 5.3 kg/cm ² (75 psi)	Display is OFF when system is normal . Display is ON when system is outside normal operating range. In addition, Central Warning Lamp and buzzer will turn ON.
		Engine Coolant Temperature On above 102°C (216°F)	
		Torque Converter Oil Temperature On above 120°C (248°F)	
		Retarder Oil Temperature On above 120°C (248°F)	
		Automatic Shift Control	OFF when operation is Normal. ON if fault occurs in Transmission Shift Controller system. Light will flash, and Central Warning Light and Alarm Buzzer will turn ON.
		Engine Control System	OFF when Normal When there is any Fault, lamp flashes, Central Warning Lamp lights up, and Alarm Buzzer sounds.
		Other Control System	OFF when Normal When there is any Fault, lamp flashes, Central Warning Lamp lights up, and Alarm Buzzer sounds.
		Fuel Level On when below LOW level	Display is OFF when fuel is above LOW level. Display flashes ON/OFF and Central Warning Light is ON when fuel is LOW.

D030096

FIGURE 3-8. MONITOR PANEL DISPLAYS, FUNCTIONS

SECTION D4

INTRODUCTION TO ELECTRICAL TROUBLESHOOTING

INDEX

POINTS TO REMEMBER WHEN TROUBLESHOOTING	D4-3
POINTS TO REMEMBER WHEN PERFORMING MAINTENANCE	D4-4
POINTS TO REMEMBER WHEN HANDLING ELECTRIC EQUIPMENT	D4-4
Handling Controller Boxes	D4-9
POINTS TO REMEMBER WHEN SERVICING HYDRAULIC EQUIPMENT	D4-10
CHECKS BEFORE TROUBLESHOOTING	D4-12
CONNECTOR TYPE AND LOCATION	D4-13
CONNECTOR LOCATION (Chassis)	D4-20
CONNECTOR LOCATION (Instrument Panel, Console)	D4-22
CONNECTOR LOCATION (Transmission, Rear Cab Area)	D4-23
CONNECTOR LOCATION (General Cab Area)	D4-24
CONNECTOR TYPE IDENTIFICATION CHARTS	D4-25
EXPLANATIONS OF FUNCTIONS (CONTROL MECHANISM) OF ELECTRICAL SYSTEM	D4-35
SYSTEM FUNCTION	D4-35
SELF-DIAGNOSTIC DISPLAY FUNCTIONS	D4-35
CHECKING OPERATION OF ELECTRICAL SYSTEM (No System Faults)	D4-37
LOCK-UP FUNCTION CHECK	D4-38
OPTIONAL CONTROLLERS	D4-38
MONITOR PANEL ACTION CODES AND SERVICE MODE	D4-39
OUTLINE	D4-39
ACTION CODE DISPLAY	D4-39
Service Mode	D4-40
SERVICE MODE OPERATION	D4-44
Brake Air Pressure Sensor	D4-52
SELF-DIAGNOSTIC DISPLAY METHOD FOR MONITOR PANEL AND CONTROLLERS	D4-53
MONITOR PANEL	D4-53
TRANSMISSION CONTROLLER	D4-53

CHECKS BEFORE TROUBLESHOOTING

		Item	Standard Values	Action
1. Checks before starting	Air Circuit, hydraulic oil, lubricating oil, cooling water,	1. Check fuel level 2. Check for dirt or water in fuel 3. Check for water in air tank 4. Check transmission oil level 5. Check hydraulic oil level 6. Check engine oil level (Level of oil in oil pan) 7. Check cooling water level 8. Check condition of dust indicator 9. Check front brake oil level (Level of oil in tank) 10. Check for water in emergency brake air tank	Fuel gauge - - Oil level gauge Sight gauge Oil level gauge - Dust indicator Oil level gauge -	Add fuel Clean, drain Drain Add oil Add oil Add oil Add water Clean Add oil Drain
	Air, hydraulic, mechanical components	11. Check play of steering wheel 12. Check operation of emergency steering 13. Check length of suspension for proper charge 14. Check tire inflation pressure and damage 15. Check wheel mounting nuts 16. Check operation of service brake 17. Check operation of parking brake 18. Check operation of emergency brake 19. Check operation of steering 20. Check the right and left view mirror 21. Check exhaust color and engine for abnormal noise 22. Check operation of retarder 23. Check wear of body pads	100-140 mm Operation: 20 sec. Label - - - - - - - - - - -	- Repair Adjust Charge air Tighten Adjust Adjust or repair Adjust or repair Adjust or repair Adjust Adjust or repair Adjust or repair Adjust or repair
	Electrical equipment	24. Check air horn 25. Check function of lights 26. Check function of gauges 27. Check monitor panel 28. Check truck monitor system 29. Check central warning light 30. Check for loose or corroded battery terminals 31. Check for loose or corroded alternator terminals 32. Check for loose or corroded starting motor terminals	- - - - - - - - -	Repair Repair or replace Adjust or replace Adjust or replace Repair or replace Repair or replace Re-tighten or clean Re-tighten or clean Re-tighten or clean
2. Other check Items	Hydraulic, Mechanical components	33. Check abnormal noise or smell 34. Check for oil leakage 35. Bleed air from all systems	- - -	Repair Repair Bleed air
	Electrical components	36. Check battery voltage (engine stopped) 37. Check level of battery electrolyte 38. Check for discolored, burnt, or bare wiring 39. Check for missing wiring clamps, hanging wire 40. Checks for water leaking onto wiring (check carefully water leakage at connectors and terminals) 41. Check for broken or corroded fuses 42. Check alternator voltage (engine running at over half throttle) 43. Noise when battery relay is operated. (Switch starting switch from ON to OFF)	20-30 V - - - - - - 27.5-29.5V	Replace Add or replace Replace Repair Disconnect connector and dry connection Replace Replace Replace

CONNECTOR LOCATION (Transmission, Rear Cab Area)

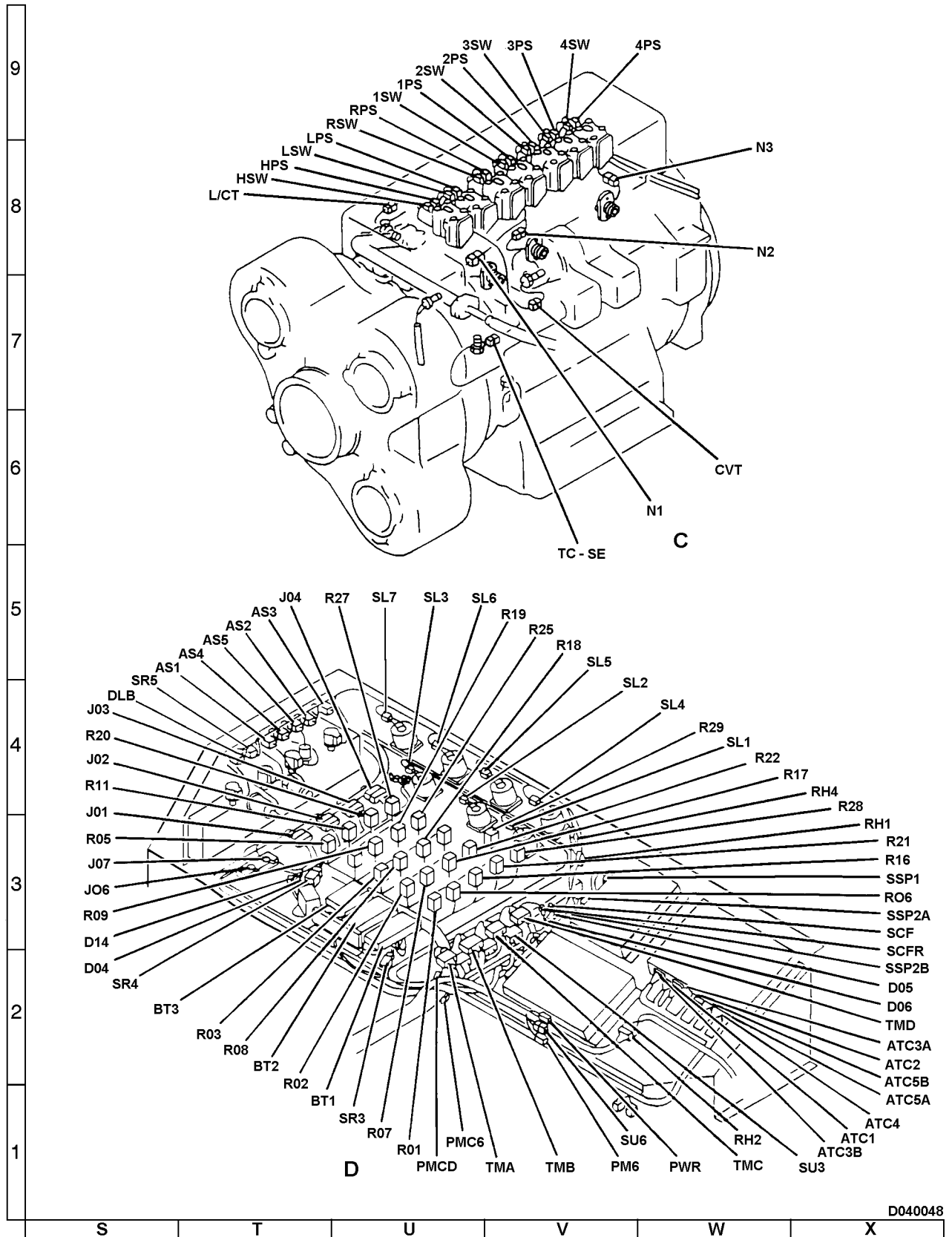
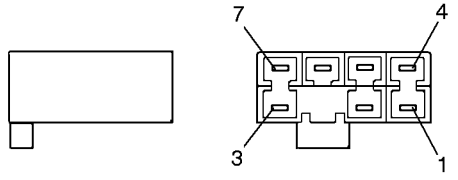
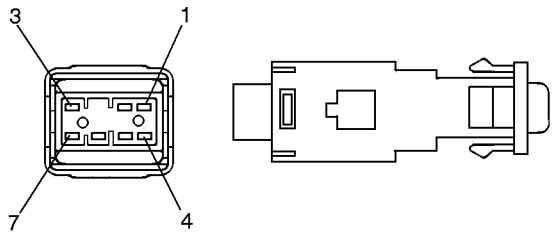
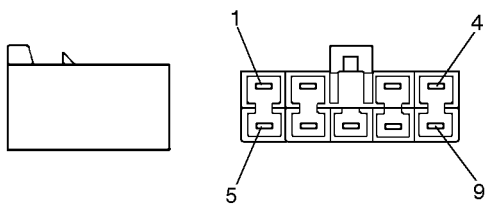
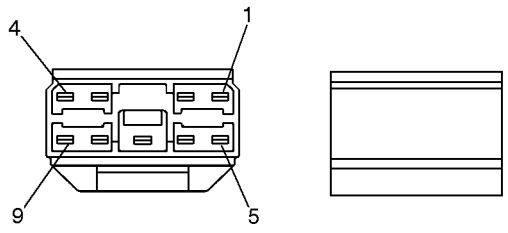

FIGURE 4-26. CONNECTOR LOCATIONS

PA connector

MALE (female housing)	No. of Pins	FEMALE (male housing)
	7	
	9	

D040084

Operation B: Changing display in truck data monitoring mode

1. When the system enters the truck data monitoring mode, it automatically displays first standard service meter on the monitor panel (controller code: A).
2. To go on to the next display, press switch (1) to the ON position for 0.2 - 2.5 seconds, then OFF. (Operation B)
3. To go back to the previous item, press switch (2) to the ON position for 0.2 - 2.5 seconds, then OFF. (Operation D)
4. After pressing mode change switch (1) to the ON position for at least 2.5 seconds, turn it OFF. (Operation C) The system will then move to the next controller and display the first item.
5. After holding switch (2) pressed to the ON position for at least 2.5 seconds, then OFF, (Operation E) the system will then move to the previous controller and display the first item.

Operation C: Changing display items in service code and trouble data display mode

1. When the system enters the service code and trouble data display mode, it first displays the elapsed time since the latest deletion. Then it automatically displays the first trouble data item on the monitor panel (controller code: A).
2. If there is no trouble data in the monitor panel memory, — is displayed.
3. To go on to the next item, press switch (1) to the ON position for 0.2 - 2.5 seconds, then OFF. (Operation B)
4. To go back to the previous item, press switch (2) to the ON position for 0.2 - 2.5 seconds, then OFF. (Operation D)
5. After pressing switch (1) to the ON position for at least 2.5 seconds, then OFF. (Operation C) The system will then move to the previous controller and display the first item of data.

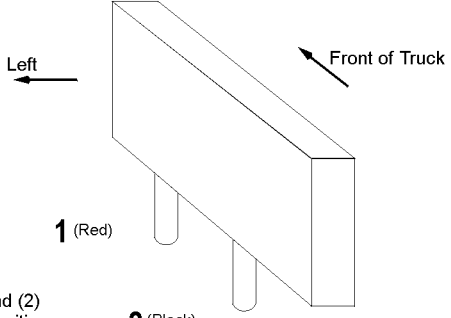
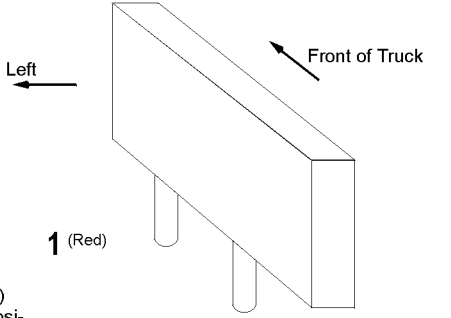
Name of operation	Method of operation	Function
A	 <p>Keep switches (1) and (2) pressed to the ON position at the same time for at least 0.2 seconds</p>	Switches display mode (See diagram for operation cycle for Method of operating Service Mode)
B	 <p>Keep switch (1) (red) pressed to the ON position for 0.2 - 2.5 seconds</p>	Advances to next display item in same mode (See diagram for operation cycle)

D040063

TABLE 1: METHODS OF OPERATING SWITCHES

2. Transmission mode display

The transmission controller always displays if the transmission is being controlled in the normal temperature mode or in the low temperature mode.

Transmission mode display		
	When normal	When abnormality is detected
Normal temperature mode	0.0	After E. [] is displayed, code is displayed to show a fault
Low temperature mode	0.C	After E.C is displayed, code is displayed to show a fault

3. Saving self-diagnostic display to memory

Once an fault is detected, even if the fault is removed, self-diagnostic display remains displayed for 5 minutes.

NOTE: The action code display on the monitor panel, the electronic controller display, warning lamp, and buzzer stop when the fault is removed.

NOTE: Even when two or more faults occur at the same time, all the fault occurrence data are transmitted to the network and the self-diagnostic display is given.

Display method: The code display starts with the faults that have occurred in order, and after completing the display of the content of all the faults, the display returns to the first code display. It continues to repeat this order. If the fault is repaired, it returns to the normal display 5 minutes after the repair.

METHOD OF DELETING DATA FROM TRANSMISSION CONTROLLER MEMORY

(CONTROL FROM MONITOR PANEL)

NOTE: For details, see Monitor Panel Action Code And Service Mode Function in the Foreword of the Troubleshooting Section.

A. Outline

NOTE: If the transmission controller is going to be used on another truck, delete the trouble data and other data related to the current truck from the memory of the transmission controller and PMC as follows.

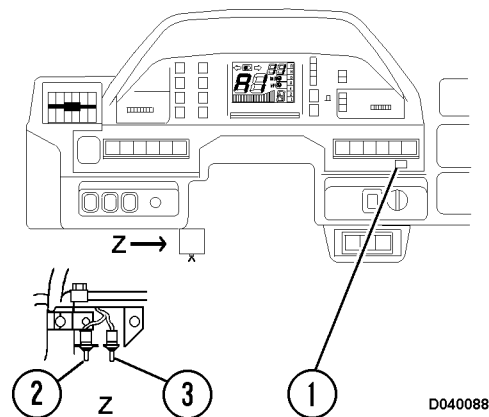

FIGURE 4-55. MODE SWITCHES

1. This function is used to delete data from the memory of the transmission controller and PMC.
2. This function is effected by operating bulb check switch (1, Figure 4-55) and mode change switches (2) (the red switch at the front of the truck and (3) (the black switch at the rear of the machine) and using the S-NET to send the command from the monitor panel to each controller to delete the data from memory.
3. The monitor panel accepts the operation for their function only when the key switch is ON and the engine is stopped. In addition, each controller also accepts the operation for this function only when the key switch in ON and the engine is stopped.
4. To prevent the data from being deleted from the memory of the wrong controller, an instrument panel caution display (5, Figure 4-56) lights up to make it possible to confirm the controller from which the data is being deleted.

1. Bulb Check Switch
2. Mode Switch (Red)
3. Mode Switch (Black)

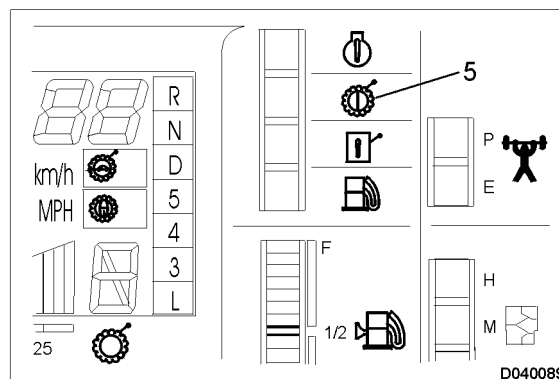

FIGURE 4-56. CONFIRMING DATA DELETION

5. Caution Light

Display code	Fault Conditions ◆ Possible causes:	Details of fault Check the wiring harnesses and equipment given below: Disconnection, short circuit in wiring harness (+): Positive, (-): Negative
b005 (E. ↔ 0.5) (E.C ↔ 0.5)	Double engagement of clutch ◆ With double engagement of clutch, input of fill sensor signal was detected Double engagement: Actuated for 2.1 - 4.7 sec	1. Defective controller 2. Defective fill switch 3. Between H SW - TM3 (3) - ATC5A (12) Between L SW - TM3 (6) - ATC5A (10) Between R SW - TM3 (9) - ATC5A (13) Between 1 SW - TM4 (3) - ATC5A (14) Between 2 SW - TM4 (6) - ATC5A (15) Between 3 SW - TM4 (9) - ATC5A (11) Between 4 SW - TM4 (12) - ATC5A (16)
b006 (E. ↔ 0.6) (E.C ↔ 0.6)	Disconnection, short circuit, short circuit with ground in transmission cut relay ◆ Transmission cut relay output terminal voltage • When actuated: > 11V • When not actuated: < 11V	1. Defective transmission cut relay 2. Between ATC1 (15) - TMC (3) - R25 (2), (1) (transmission cut relay) BT1 fuse No. 10
b007 (E. ↔ 0.7) (E.C ↔ 0.7)	Short circuit with ground in 12V output circuit (Shift lever power supply) ◆ 12V output terminal voltage, < 6V	1. Between (+) ATC2 (14) - TMB (1) - SF (1) 2. Defective voltage circuit inside controller
b008 (E. ↔ 0.8) (E.C ↔ 0.8)	Disconnection, short circuit, short circuit with ground in rear brake prevention solenoid ◆ Rear brake • When actuated: > 11V • When not actuated < 11V	1. Between (+) ASTC1 (13) - TMB (16) - RH4 (6) - SL4 (1) 2. Between (-) SL4 (2) - RH4 (5) - GND ER 3. Between (+) ATC1 (5) - TMC (10) - BT1 fuse No. 10 4. Defective rear brake solenoid
b009 (E. ↔ 1.0) (E.C ↔ 1.0)	Disconnection, short circuit, short circuit with ground in exhaust brake solenoid ◆ Exhaust brake • When actuated: > 11V • When not actuated: < 11V	1. Between (+) ATC1 (14) - TMB (15) - RH4 (5) - GND ER 2. Between (-) SL5 (2) - RH4 (5) - GND ER 3. Between (+) SL5 (1) RH4 (5) - BT1 fuse No. 10 4. Defective exhaust brake solenoid
b010 (E. ↔ 1.0) (E.C ↔ 1.0)	Defective engine speed sensor output ◆ Engine speed less than 350 rpm and transmission speed more than 500 rpm continues for 10 sec.	1. Engine speed sensor 1) Between E12 (1) - J09M (9) - TMD (13) - ATC3A (13) 2) Between E12 (2) - J09M (10) - TMD (14) - ATC3A (14) 2. Defective engine speed sensor
b011 (E. ↔ 1.1) (E.C ↔ 1.1)	Disconnection in transmission input shaft speed sensor ◆ If disconnection detection is actuated but there is no sensor signal	1. Input shaft speed sensor 1) Between N1 (1) - TM2 (1) - ATC3A (2) 2) Between N2 (2) - TM2 (2) - ATC3A (14) 2. Defective input shaft speed sensor
b012 (E. ↔ 1.2) (E.C ↔ 1.2)	Defective transmission intermediate shaft speed sensor output ◆ If disconnection detection is actuated but there is no sensor signal	1. Intermediate shaft speed sensor 1) Between N2 (1) - TM2 (3) - ATC3A (12) 2) Between N2 (2) - TM2 (4) - ATC3A (14)

The top code in the Display code column shows the monitor panel display and the bottom code (in []) shows the transmission controller LED display. (< less than - > greater than)

Condition when normal: Check with tester Voltage (V), current (A), resistance value Ω	Action of controller when a fault is detected	Symptoms that appear in truck when there is a fault Mechatronics display given, warning actuated																						
Check with Table 2 for the items for display codes b071 - b078 (E. \leftrightarrow 7.1, E.C \leftrightarrow 7.1 - E. \leftrightarrow 7.8, E.C \leftrightarrow 7.8)	Actuates transmission cut relay and shifts to Neutral	Transmission suddenly shifts to Neutral during propel or truck cannot move again																						
Check with Table 2 for the items for display codes b071 - b078 (E. \leftrightarrow 7.1, E.C \leftrightarrow 7.1 - E. \leftrightarrow 7.8, E.C \leftrightarrow 7.8)	Actuates transmission cut relay and shifts to Neutral	Transmission suddenly shifts to Neutral during propel or truck cannot move again																						
Check with Table 2 for the items for display codes b071 - b078 (E. \leftrightarrow 7.1, E.C \leftrightarrow 7.1 - E. \leftrightarrow 7.8, E.C \leftrightarrow 7.8)	Actuates transmission cut relay and shifts to Neutral	Transmission suddenly shifts to Neutral during propel or truck cannot move again																						
When each gear range is engaged using the shift checker, the fill switch signal is given with the combinations shown in Table1. Table 2 Solenoid valve check																								
<table border="1"> <thead> <tr> <th>ATC1 (female)</th> <th>ATC2 (female)</th> <th>Ω</th> </tr> </thead> <tbody> <tr> <td>Between (1) - (8), (16)</td> <td>—</td> <td>30 - 80 Ω</td> </tr> <tr> <td rowspan="6">—</td> <td>Between (9) - (19)</td> <td rowspan="6">5 - 25 Ω</td> </tr> <tr> <td>Between (7) - (17)</td> </tr> <tr> <td>Between (2) - (13)</td> </tr> <tr> <td>Between (4) - (15)</td> </tr> <tr> <td>Between (3) - (13)</td> </tr> <tr> <td>Between (8) - (18)</td> </tr> <tr> <td>Between (5) - (15)</td> <td></td> </tr> <tr> <td>Resistance value between each terminal</td> <td></td> <td>> 1 MΩ</td> </tr> <tr> <td>Between each terminal - chassis</td> <td></td> <td>> 1 MΩ</td> </tr> </tbody> </table>	ATC1 (female)	ATC2 (female)	Ω	Between (1) - (8), (16)	—	30 - 80 Ω	—	Between (9) - (19)	5 - 25 Ω	Between (7) - (17)	Between (2) - (13)	Between (4) - (15)	Between (3) - (13)	Between (8) - (18)	Between (5) - (15)		Resistance value between each terminal		> 1 M Ω	Between each terminal - chassis		> 1 M Ω	<p>Even when a disconnection is detected, it tries to send current to the solenoid</p> <ul style="list-style-type: none"> This is because there is no danger of damage to the controller even if there is a disconnection 	<ol style="list-style-type: none"> Power is lost when propelling, and when shifting up, transmission immediately shifts down again This frequently happens when going uphill loaded <ol style="list-style-type: none"> Shift indicator display shows "E"
ATC1 (female)	ATC2 (female)	Ω																						
Between (1) - (8), (16)	—	30 - 80 Ω																						
—	Between (9) - (19)	5 - 25 Ω																						
	Between (7) - (17)																							
	Between (2) - (13)																							
	Between (4) - (15)																							
	Between (3) - (13)																							
	Between (8) - (18)																							
Between (5) - (15)																								
Resistance value between each terminal		> 1 M Ω																						
Between each terminal - chassis		> 1 M Ω																						
Check with Table 2 for the items for display codes b091 - b098 (E. \leftrightarrow 9.1, E.C \leftrightarrow 9.1 - E. \leftrightarrow 9.8, E.C \leftrightarrow 9.8)	See items for display codes b091 - b098 (E. \leftrightarrow 9.1, E.C \leftrightarrow 9.1- E \leftrightarrow 9.8, E.C \leftrightarrow 9.8)	See items for display codes b091 - b098 (E. \leftrightarrow 9.1, E.C \leftrightarrow 9.1- E \leftrightarrow 9.8, E.C \leftrightarrow 9.8)																						
Check with Table 2 for the items for display codes b091 - b098 (E. \leftrightarrow 9.1, E.C \leftrightarrow 9.1 - E. \leftrightarrow 9.8, E.C \leftrightarrow 9.8)	See items for display codes b091 - b098 (E. \leftrightarrow 9.1, E.C \leftrightarrow 9.1- E \leftrightarrow 9.8, E.C \leftrightarrow 9.8)	See items for display codes b091 - b098 (E. \leftrightarrow 9.1, E.C \leftrightarrow 9.1- E \leftrightarrow 9.8, E.C \leftrightarrow 9.8)																						
Check with Table 2 for the items for display codes b091 - b098 (E. \leftrightarrow 9.1, E.C \leftrightarrow 9.1 - E. \leftrightarrow 9.8, E.C \leftrightarrow 9.8)	See items for display codes b091 - b098 (E. \leftrightarrow 9.1, E.C \leftrightarrow 9.1- E \leftrightarrow 9.8, E.C \leftrightarrow 9.8)	See items for display codes b091 - b098 (E. \leftrightarrow 9.1, E.C \leftrightarrow 9.1- E \leftrightarrow 9.8, E.C \leftrightarrow 9.8)																						
Check with Table 2 for the items for display codes b091 - b098 (E. \leftrightarrow 9.1, E.C \leftrightarrow 9.1 - E. \leftrightarrow 9.8, E.C \leftrightarrow 9.8)	See items for display codes b091 - b098 (E. \leftrightarrow 9.1, E.C \leftrightarrow 9.1- E \leftrightarrow 9.8, E.C \leftrightarrow 9.8)	See items for display codes b091 - b098 (E. \leftrightarrow 9.1, E.C \leftrightarrow 9.1- E \leftrightarrow 9.8, E.C \leftrightarrow 9.8)																						
Check with Table 2 for the items for display codes b091 - b098 (E. \leftrightarrow 9.1, E.C \leftrightarrow 9.1 - E. \leftrightarrow 9.8, E.C \leftrightarrow 9.8)	See items for display codes b091 - b098 (E. \leftrightarrow 9.1, E.C \leftrightarrow 9.1- E \leftrightarrow 9.8, E.C \leftrightarrow 9.8)	See items for display codes b091 - b098 (E. \leftrightarrow 9.1, E.C \leftrightarrow 9.1- E \leftrightarrow 9.8, E.C \leftrightarrow 9.8)																						
Check with Table 2 for the items for display codes b091 - b098 (E. \leftrightarrow 9.1, E.C \leftrightarrow 9.1 - E. \leftrightarrow 9.8, E.C \leftrightarrow 9.8)	See items for display codes b091 - b098 (E. \leftrightarrow 9.1, E.C \leftrightarrow 9.1- E \leftrightarrow 9.8, E.C \leftrightarrow 9.8)	See items for display codes b091 - b098 (E. \leftrightarrow 9.1, E.C \leftrightarrow 9.1- E \leftrightarrow 9.8, E.C \leftrightarrow 9.8)																						
Check with Table 2 for the items for display codes b091 - b098 (E. \leftrightarrow 9.1, E.C \leftrightarrow 9.1 - E. \leftrightarrow 9.8, E.C \leftrightarrow 9.8)	See items for display codes b091 - b098 (E. \leftrightarrow 9.1, E.C \leftrightarrow 9.1- E \leftrightarrow 9.8, E.C \leftrightarrow 9.8)	See items for display codes b091 - b098 (E. \leftrightarrow 9.1, E.C \leftrightarrow 9.1- E \leftrightarrow 9.8, E.C \leftrightarrow 9.8)																						
Check with Table 2 for the items for display codes b091 - b098 (E. \leftrightarrow 9.1, E.C \leftrightarrow 9.1 - E. \leftrightarrow 9.8, E.C \leftrightarrow 9.8)	See items for display codes b091 - b098 (E. \leftrightarrow 9.1, E.C \leftrightarrow 9.1- E \leftrightarrow 9.8, E.C \leftrightarrow 9.8)	See items for display codes b091 - b098 (E. \leftrightarrow 9.1, E.C \leftrightarrow 9.1- E \leftrightarrow 9.8, E.C \leftrightarrow 9.8)																						

c) Drop in voltage of battery direct power source is displayed

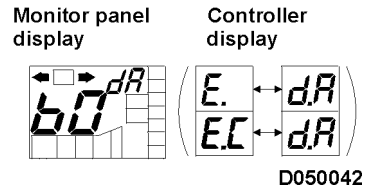

- When fuse BT2 (8) (15 - 16) is normal. If it is blown, check for a short circuit with the ground inside the controller and in the wiring harness between the fuse and controller.
- When the battery is normal.
- Before carrying out troubleshooting, check that all the related connectors are properly inserted.
- Always connect any disconnected connectors before going on the next step.

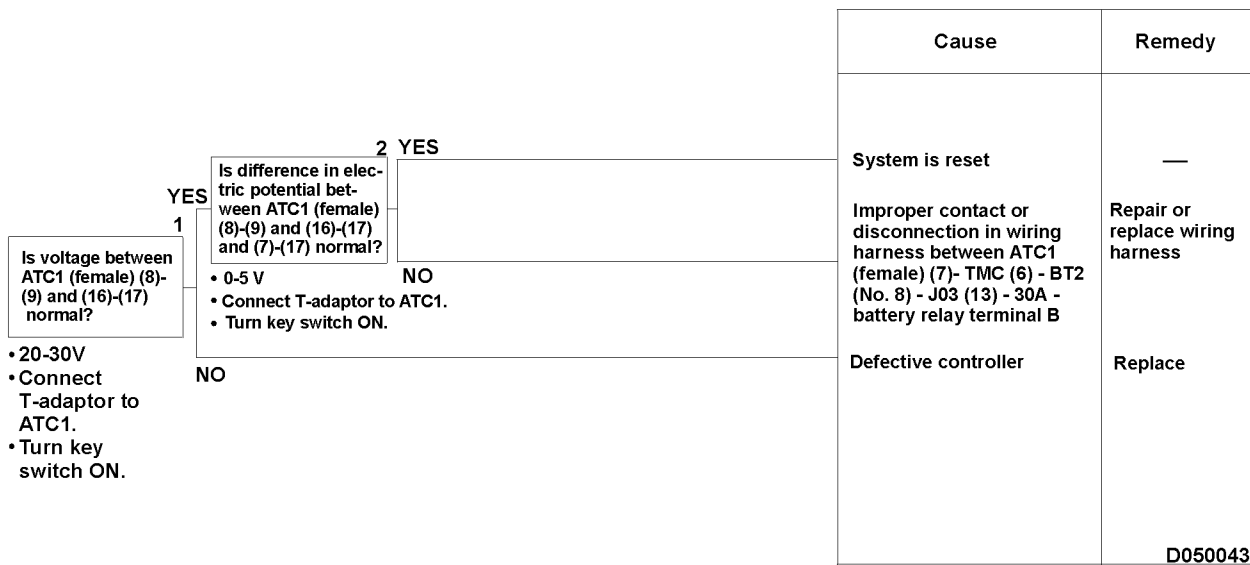

A-1 c) Related electrical circuit diagram

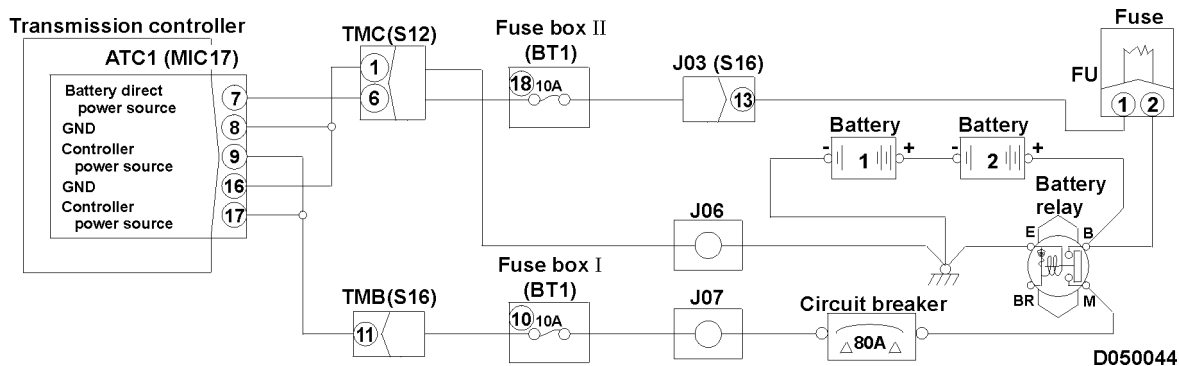

A-8 FAULT IN SPEED SENSOR

a) Disconnection in engine speed sensor [B] is displayed on truck

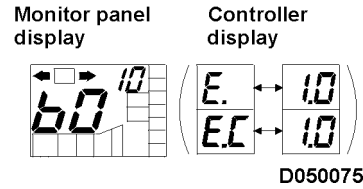

or

Failure of engine speed sensor is displayed on truck

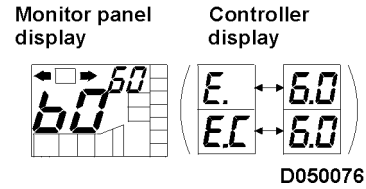

- Before carrying out troubleshooting, check that all the related connectors are properly inserted.
- Always connect any disconnected connectors before going on to the next step.

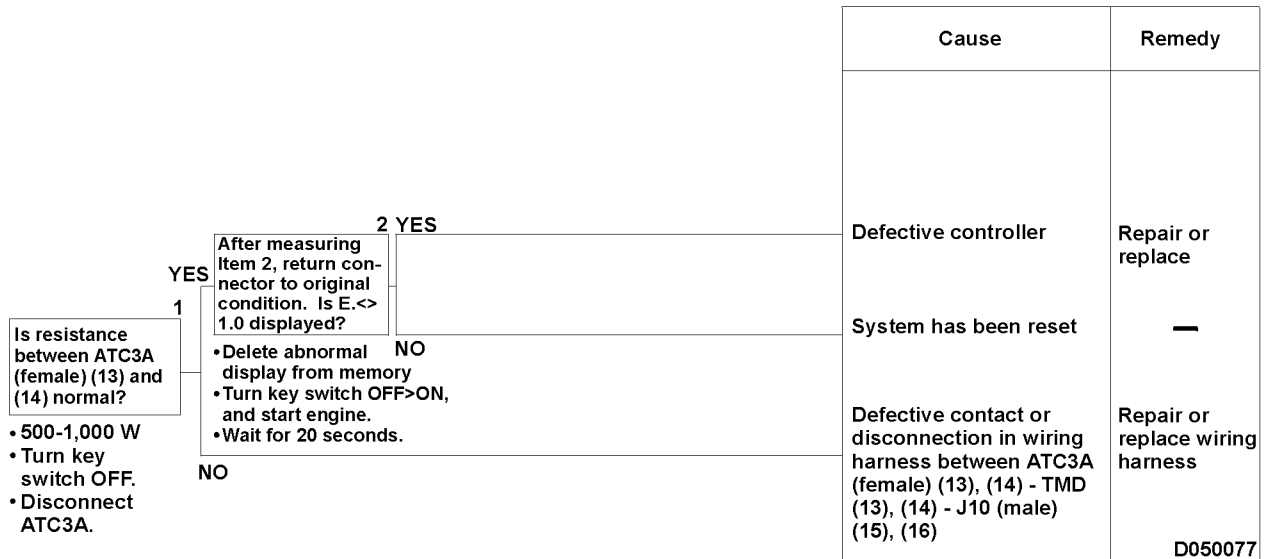

A-8 a) Related electrical circuit diagram

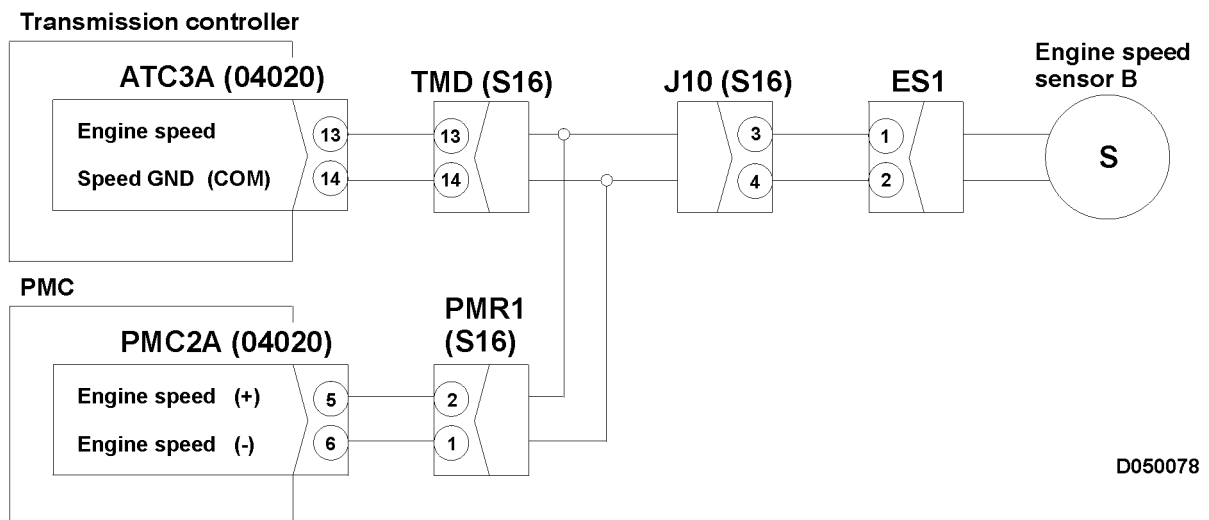

c) Shift lever position signal is not inputted

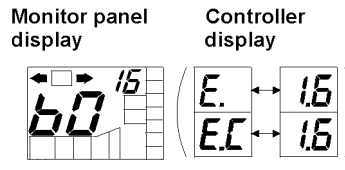

- Before carrying out troubleshooting, check that all the related connectors are properly inserted.
- Always connect any disconnected connectors before going on to the next step.

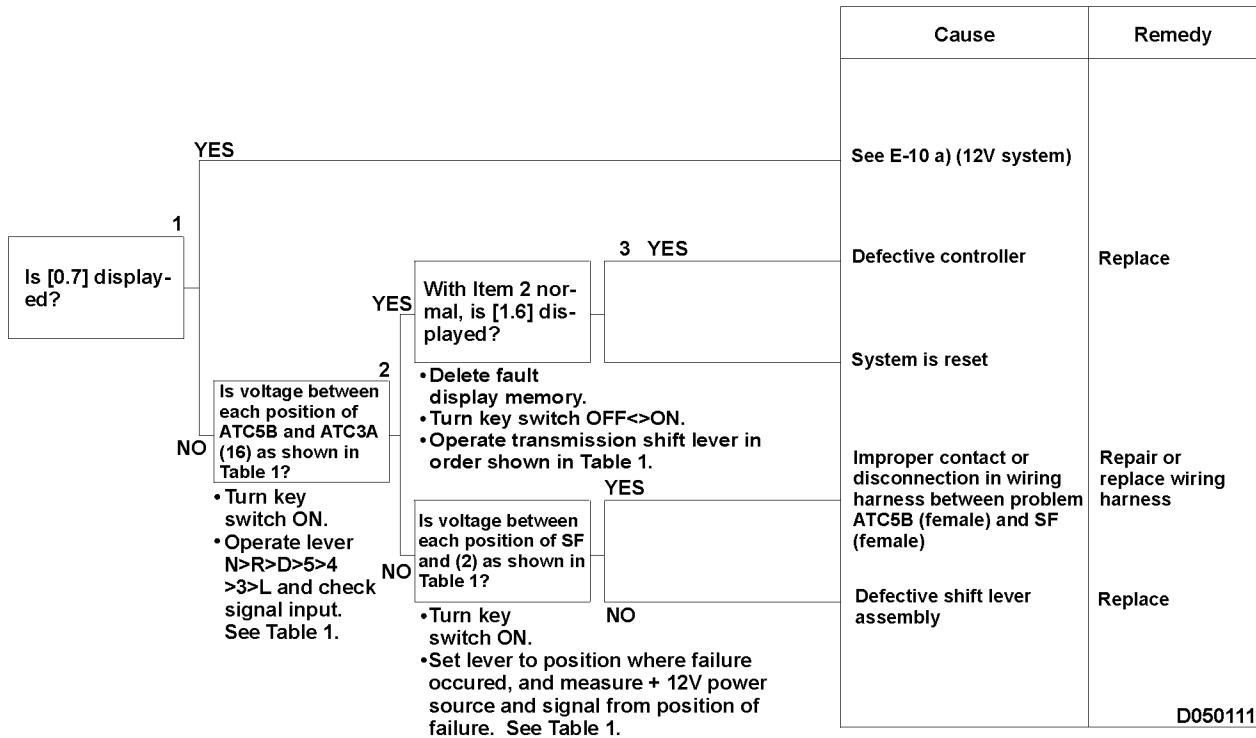
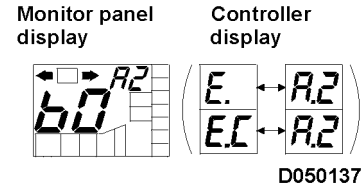

Table 1

Lever position	Terminal of TORQFLOW transmission controller	Voltage when position is selected	Voltage when position is not selected	Shift lever SF terminal
N	ATC5B (3)	< 1.0 V	> 15.0 V	SF (4)
R	ATC5B (2)	< 1.0 V	> 15.0 V	SF (3)
D	ATC5B (4)	< 1.0 V	> 15.0 V	SF (5)
5	ATC5B (5)	< 1.0 V	> 15.0 V	SF (6)
4	ATC5B (6)	< 1.0 V	> 15.0 V	SF (7)
3	ATC5B (7)	< 1.0 V	> 15.0 V	SF (8)
L	ATC5B (8)	< 1.0 V	> 15.0 V	SF (9)

A-17 FAULT IN SENSOR CIRCUITS

a) Fault in torque converter oil temperature sensor is displayed



- When the controller power source is normal.
- Before carrying out troubleshooting, check that all the related connectors are properly inserted.
- Always connect any disconnected connectors before going on to the next step.

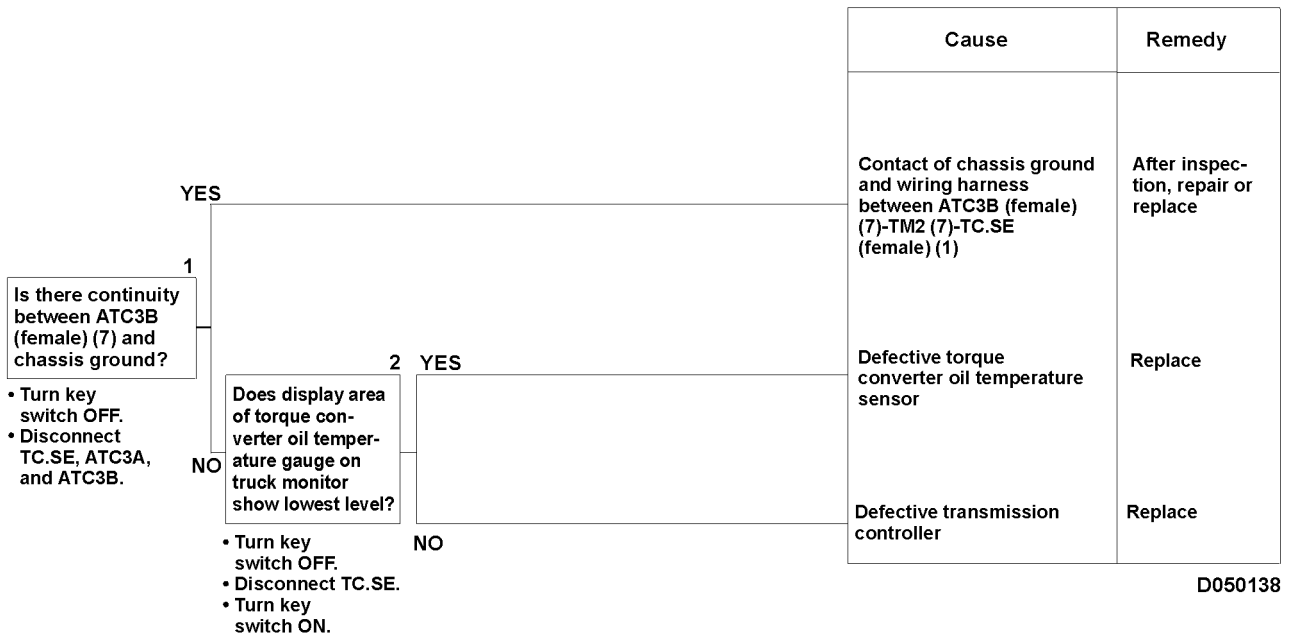

A-17 a) Related electrical circuit diagram

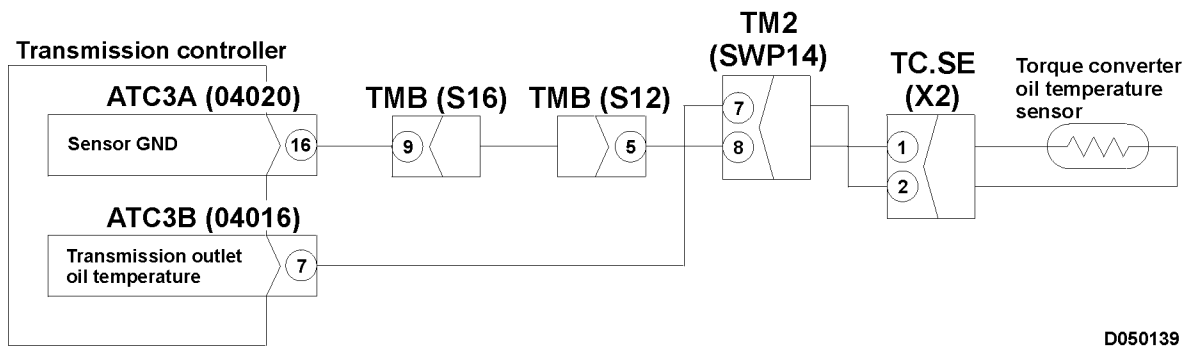

g) Rear brake oil pressure warning is displayed

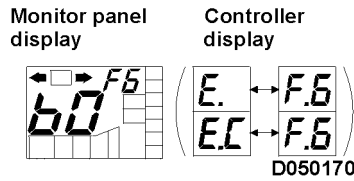

- Before carrying out troubleshooting, check if the rear brake chamber has reached the end of its stroke.
- Before carrying out troubleshooting, check that all the related connectors are properly inserted.
- Always connect any disconnected connectors before going on to the next step.

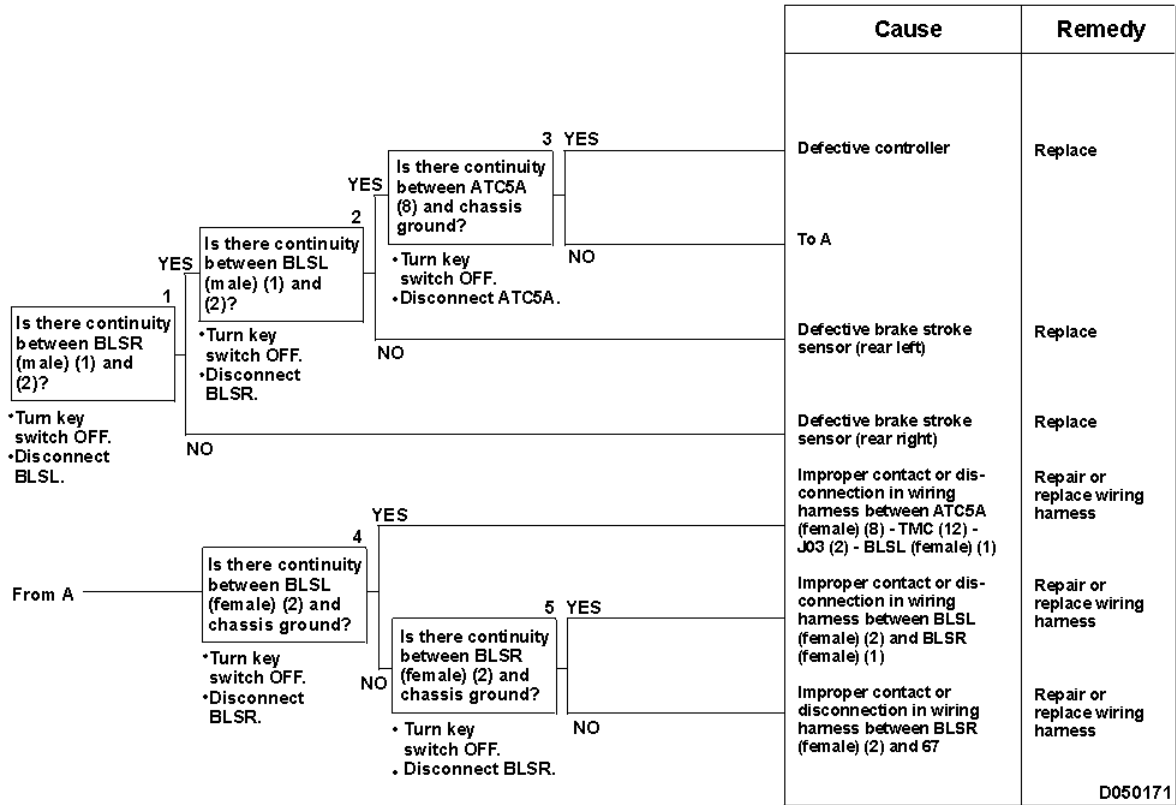

A-18 g) Related electrical circuit diagram

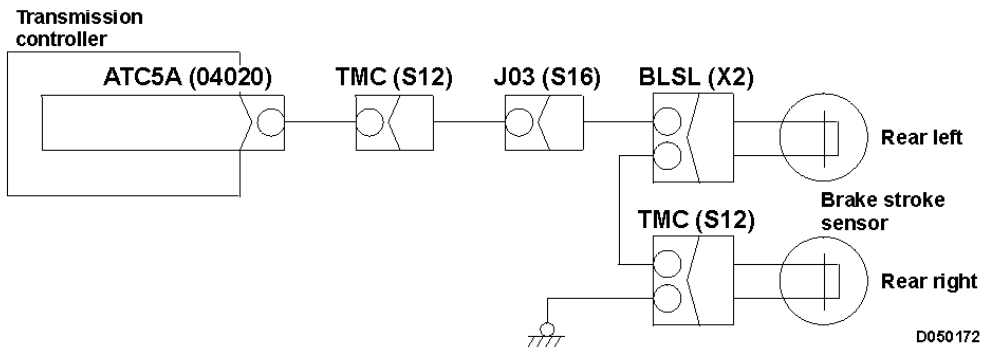

CONDITION WHEN NORMAL	CONTROLLER ACTION WHEN A FAULT IS DETECTED	TRUCK SYMPTOMS WHEN A FAULT IS PRESENT
	<ol style="list-style-type: none"> 1. Engine mechatronics caution lamp flashes. 2. Displays action code. 3. Engine Stop Lamp (red) flashes. 	<p>In some cases, the engine may not start. Engine output may be reduced or the speed may not increase.</p>
	<ol style="list-style-type: none"> 1. Engine mechatronics caution lamp flashes. 2. Displays action code. 3. Engine Protection Lamp (blue) flashes. 	<p>In some cases, the engine may not start. Engine output may be reduced or the speed may not increase.</p>
	<ol style="list-style-type: none"> 1. Engine mechatronics caution lamp flashes. 2. Displays action code. 3. Engine Check Lamp (yellow) flashes. 	<p>In some cases, the engine may not start. Engine output may be reduced or the speed may not increase.</p>

P-9 Central Warning Lamp does not operate, or monitor panel detects fault code (monitor panel display) [A002]

- Before troubleshooting, verify all connectors related to the wiring harnesses between the modules are properly inserted.
- Always connect any disconnected connectors before going on to the next step.

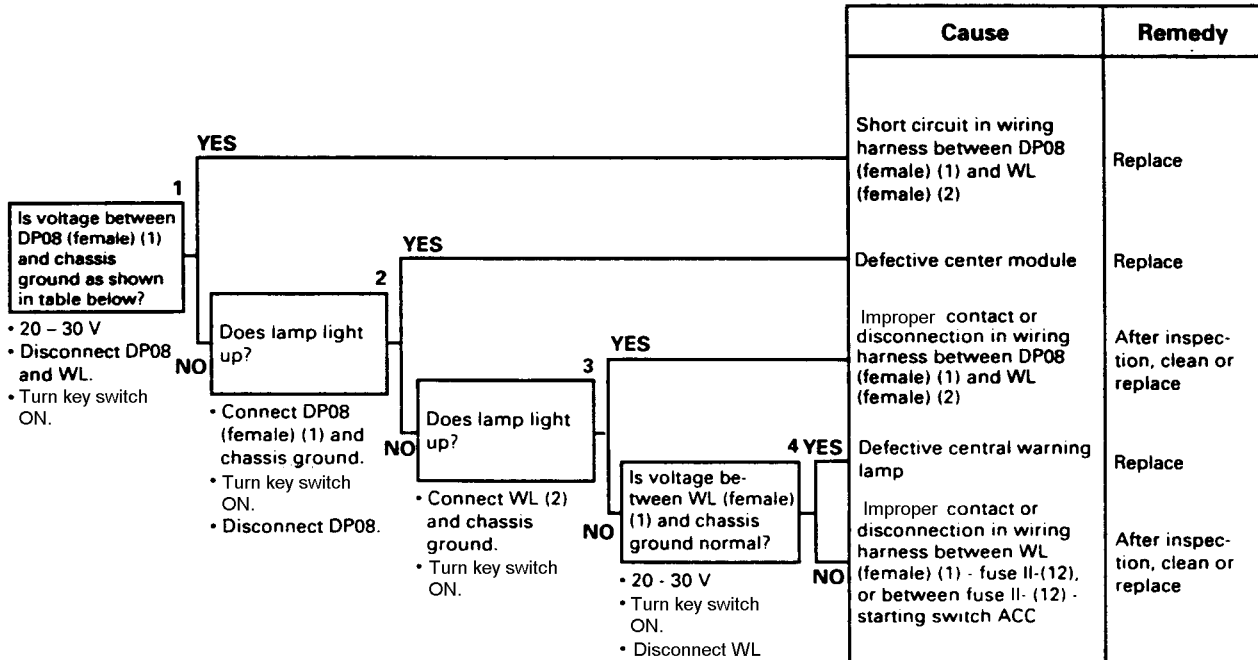

D060044

Related electrical circuit diagram

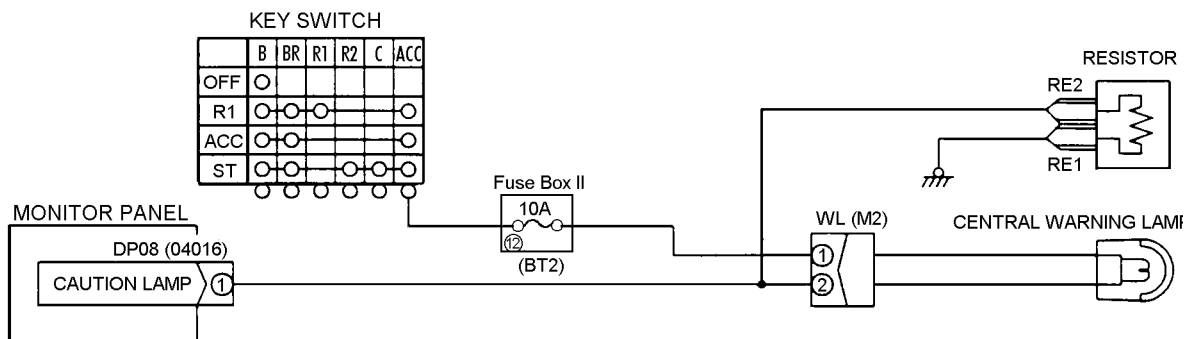

D060045

P-20 Engine oil pressure drop caution lamp does not operate, or monitor panel detects service code A001:

Monitor Panel Display

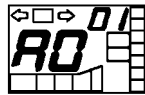

D060143

- Before troubleshooting, verify all connectors related to the wiring harnesses between the modules are properly inserted.
- Always connect any disconnected connectors before going on to the next step.

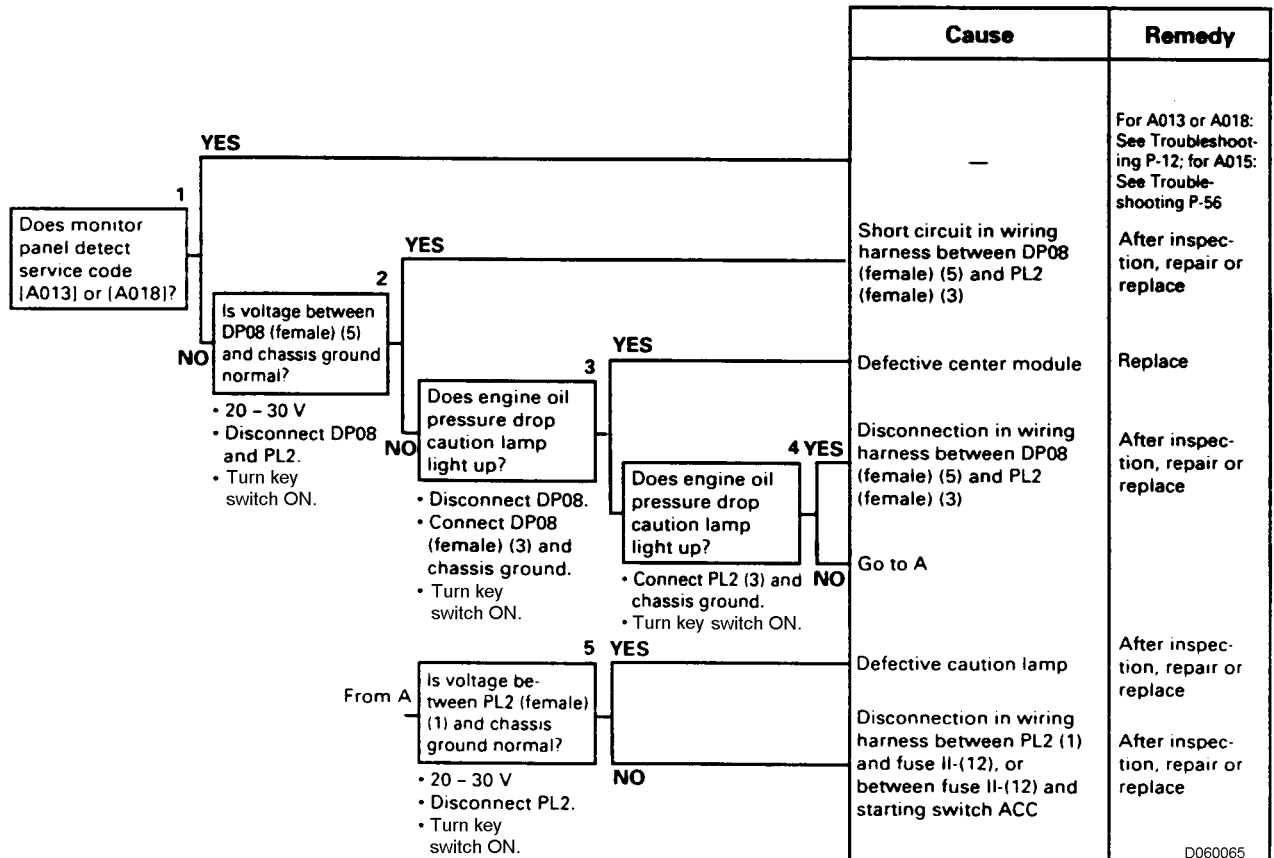

D060065

Related electrical circuit diagram

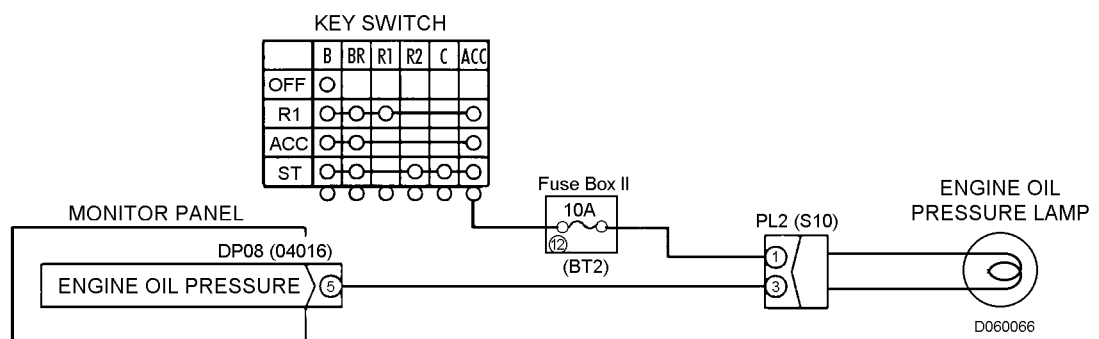

D060066

P-31 Preheating switch pilot lamp stays ON.

- Before troubleshooting, verify all connectors related to the wiring harnesses between the modules are properly inserted.
- Always connect any disconnected connectors before going on to the next step.

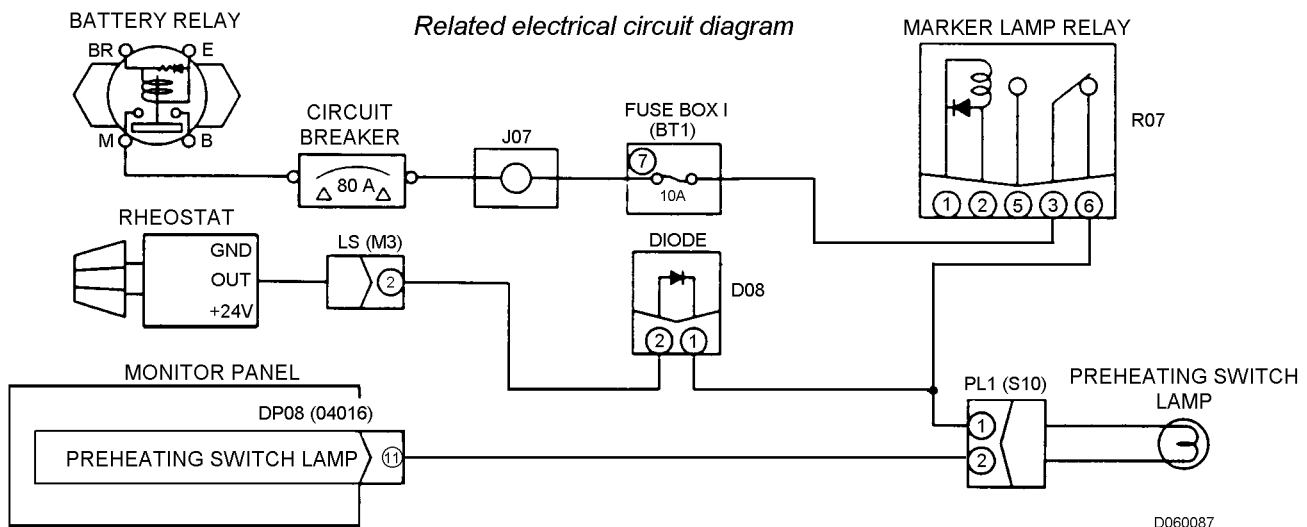
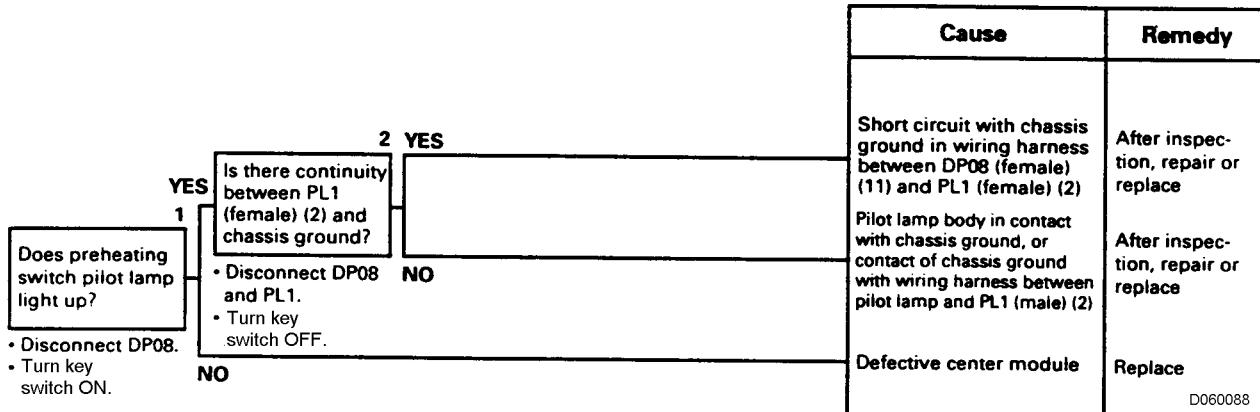

P-42 Steering oil temperature caution lamp does not operate, or monitor panel detects service code A001:

Monitor Panel Display



D060143

- Before troubleshooting, verify all connectors related to the wiring harnesses between the modules are properly inserted.
- Always connect any disconnected connectors before going on to the next step.

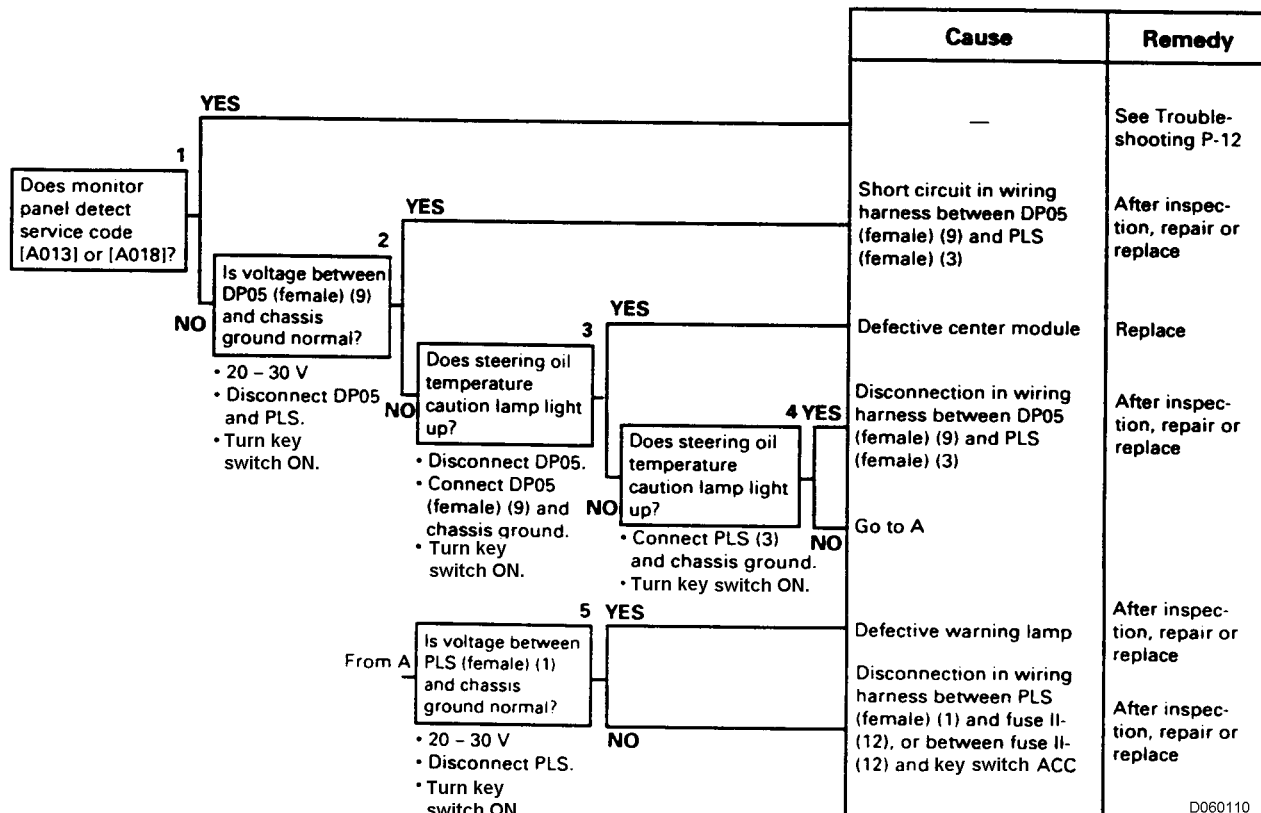

Related electrical circuit diagram

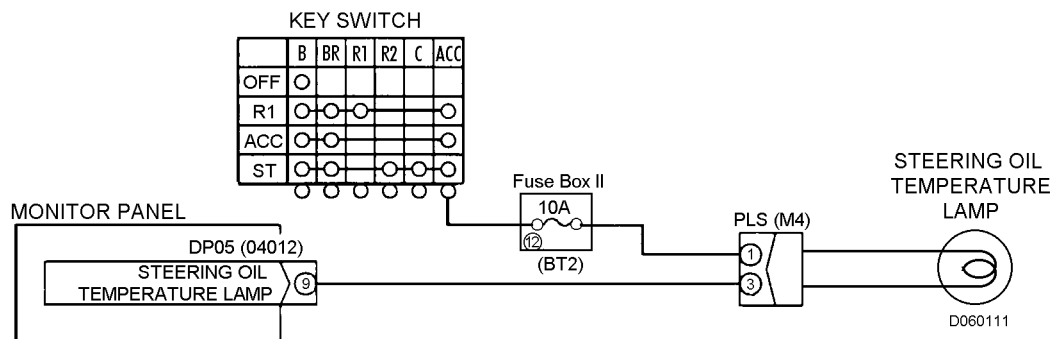

P-54 KPH/MPH speedometer unit selector does not operate

- Before troubleshooting, verify all connectors related to the wiring harnesses between the modules are properly inserted.
- Always connect any disconnected connectors before going on to the next step.

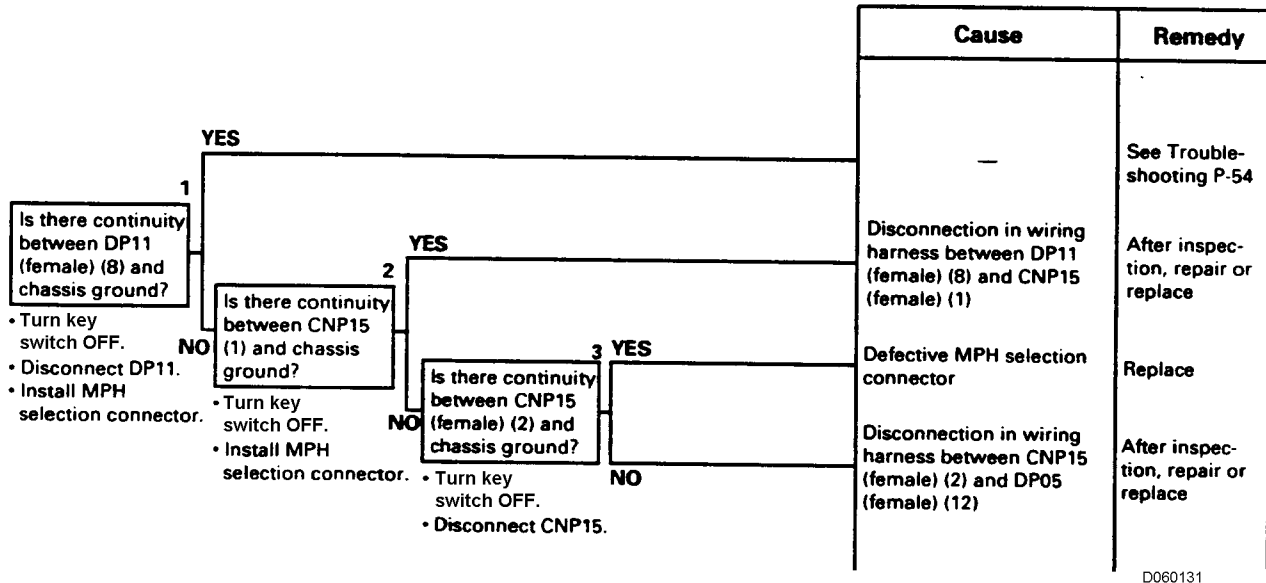

D060131

Related electrical circuit diagram

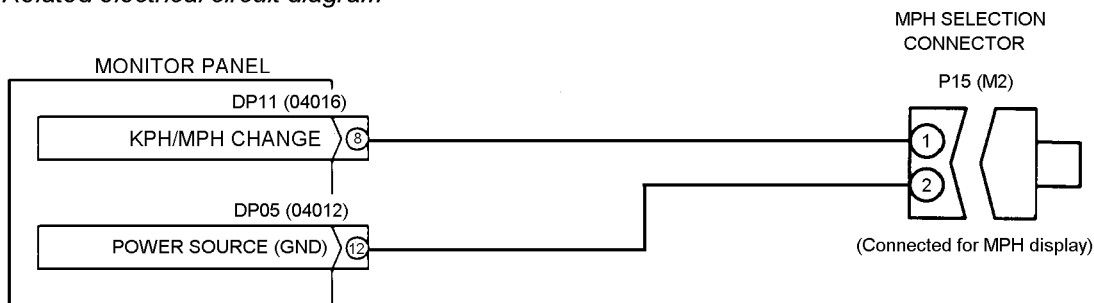

D060131

FAULT CODE LAMP	PID (P) SID (S)	SPN FMI	REASON	EFFECT (Only when fault code is active)
172 Red	S023	638 6	Fuel control rack is stuck in a position commanding excessive fueling to the engine	Engine shutdown
173 Yellow	S023	638 7	Fuel control rack is stuck in a position providing adequate, or less than adequate, fueling to the engine.	No action is taken by the ECM.
184 Red	S233	609 2	Primary and/or secondary ECM identification error.	Module identification at power up will fail, both modules will run as slaves.
221 Yellow	P108	108 3 or 4	More than 4.78 volts is detected at the ambient air pressure signal pin 32 of the engine harness.	No action is taken by the ECM.
222 Yellow	P108	108 4	Less than 0.20 volts is detected at the ambient air pressure signal pin 32 of the engine harness.	No action is taken by the ECM.
231 Yellow	P109	109 3	More than 4.72 volts is detected at the coolant pressure sensor signal pin 24 of the engine harness.	Engine protection for coolant pressure is disabled.
232 Yellow	P109	109 3	Less than 0.33 volts is detected at the coolant pressure sensor signal pin 24 of the engine harness.	Engine protection for coolant pressure is disabled.
233 Blue	P109	109 1	Low coolant pressure has been detected. Voltage signal at coolant pressure signal pin 24 of the engine harness indicates coolant pressure lower than 28 kPa (4 psi) at 800 rpm; 41 kPa (6psi) at 1300 rpm; 76 kPa (11psi) at 1800 rpm kPa (15 psi) above 2100 rpm.	Calibration dependent progressive power and speed derate and engine shutdown with increasing time after alert.
234 Red	P190	190 0	Engine speed signals on pin 17 of the engine harness indicate an engine speed greater than 2650 rpm.	The EHAB (fuel shutoff valve) is de-energized, (closed). The EHAB (fuel shutoff valve) is reenergized (opened) when engine speed falls below 2130 rpm.
235 Blue	P111	111 1	Low coolant level has been detected. Voltage signal on the coolant level signal pin 37 of the engine harness indicates low radiator coolant level in the vehicle.	Calibration-dependent progressive power and speed derate, and engine shutdown with increasing time after alert.
252 Yellow	P098	098 2	Low voltage detected at the lubricating oil level sensor supply pin 49 of the engine harness.	No action taken by the ECM.
253 Blue	P098	98 1	Voltage signal on the oil level signal pin 49 of the engine harness indicates low oil level in the engine.	Engine will not start.
254 Red	S017	632 4	Less than 16.5 volts detected at fuel shutoff valve solenoid supply pin 43 of the engine harness.	No action is taken by the ECM. Low voltage to the EHAB will cause it to stop fuel flow to the corresponding pump, and shut down that engine bank.
259 Red	S017	632 7	EHAB (fuel shutoff valve) is open and will not close.	ECM commands rack position to zero, which stops fueling corresponding engine bank.
342 Red	S253	630 13	The primary and secondary ECM calibrations do not match.	Engine will not start.
343 Yellow	S254	629 12	Microprocessor communication error internal to the ECM.	Variable; performance will or will not be affected.
346 OFF	S253	630 12	ECM power down internal data store error.	Power down data (which includes maintenance monitoring, current ECM/engine delta times, and past fault data) are lost.
415 Blue	P100	100 1	Very low oil pressure has been detected. Voltage signal at oil pressure signal pin 33 of the engine harness indicates oil pressure lower than 800 rpm; 121 kPa (17.5 psi) at 1200 rpm; 207 kPa (30 psi) at engine speeds greater than 1600 rpm.	Calibration dependent progressive power and speed derate and engine shutdown with increasing time after alert.
422 Yellow	P111	111 2	Voltage detected simultaneously on both the coolant level high and low signal pins 27 and 37 of the OEM interface harness, or no voltage detected on either pin.	No action taken by the ECM.
431 Yellow	P091	091,607 2 or 4	Voltage detected simultaneously on both the idle validation, off-idle and idle-signal pins 25 and 26 of the OEM interface harness.	None on performance.

b. Torque converter lock-up does not engage

Ask the operator the following questions:

- Did the problem suddenly happen?
YES = Internal seizure, damage
- When this happened, was there any abnormal noise?
YES = Broken part

Checks before troubleshooting

- Is the oil level in the transmission case correct?
- Is there any external oil leakage?
- Is current flowing to the lock-up solenoid? (Check using a voltmeter.)

Checking for problems:

- Main relief pressure
- Lock-up oil pressure
- Truck speed

No.	PROBLEM	CAUSE	REMEDY
1	Main relief pressure is low	a. Drop in main relief valve pressure	Repair or replace
		b. Defective lock-up solenoid	Repair or replace
2	With item 1 normal, lock-up pressure is low or "0"	a. Improper operation of lock-up solenoid valve spool	Repair or replace
		b. Improper operation of lock-up valve spool	Repair or replace
		c. Cracked lock-up clutch case	Replace
3	Solenoid is normal in item 2 (proper continuity, no short circuit)	a. Improper operation of lock-up valve spool	Repair or replace
4	Solenoid is defective in item 2 (no continuity or short circuit)	a. Improper operation of lock-up solenoid valve spool	Repair or replace
5	With items 1 - 4 normal, lock-up pressure is low	a. Worn lock-up clutch piston seal ring	Replace
		b. Worn lock-up clutch disc	Replace
6	Oil pressure is normal in item 5	a. Worn lock-up clutch disc	Replace
7	Lock-up pressure is low and main pressure is also low	a. Cracked lock-up clutch case	Replace
8	Lock-up requires excessive time to engage	a. Improper operation of lock-up valve spool	Repair or replace
		b. Worn lock-up clutch piston seal ring	Replace

H-15 Hoist cylinder lacks lifting force (lifting speed)

Checks before troubleshooting

- Is the hydraulic tank oil level correct?
- Is the control lever actuation normal?
- Is the control cable corroded?
- When the cable is disconnected at the hoist valve end, does the control lever move normally?
- Is there any external oil leakage between the pump and cylinder?

Checking for problems

- Relief pressure
- Body lifting speed

No.	PROBLEM	CAUSE	REMEDY
1	Steering wheel is also difficult to turn	a. Air sucked in at suction side of pump	Repair
		b. Clogged strainer	Clean
		c. Crushed suction tube	Repair
		d. Drop in performance of hydraulic pump	Replace
		e. Drop in performance of steering pump	Replace
		f. Drop in demand valve relief valve pressure or defective seal	Adjust, clean or replace
2	Steering wheel is normal	a. Improper operation of demand valve spool or stuck spool	Repair
		b. Improper operation of demand valve check valve	Repair
		c. Drop in hoist valve relief valve pressure or defective seal	Adjust or replace
		d. Drop in hoist valve safety valve pressure or defective seal	Adjust or replace
		e. Defective hoist valve suction valve seal	Clean or adjust
		f. Improper hoist valve check valve operation	Repair
		g. Defective hoist cylinder	Replace
3	Item 1 is defective and hoist circuit relief pressure is low	a. Air sucked in at suction side of pump	Repair
		b. Clogged strainer	Clean
		c. Crushed suction tube	Repair
		d. Drop in performance of hydraulic pump	Replace
		e. Drop in performance of steering pump	Replace
		f. Drop in demand valve relief valve pressure or defective seal	Adjust, clean or replace
4	Item 3 is abnormal and the sound of oil blowing through relief valve is heard	a. Drop in demand valve relief valve pressure or defective seal	Adjust, clean or replace
5	Hoist circuit pressure is too high at engine high idle (items 1 - 4 are normal)	a. Improper operation of demand valve check valve	Repair
		b. Improper hoist valve check valve operation	Repair
6	Only hoist circuit relief pressure is low	a. Drop in hoist valve relief valve pressure or defective seal	Adjust or replace
		b. Defective hoist cylinder	Replace

TORQUE CONVERTER

The torque converter is a 3-element, single-stage, two phase torque converter with lockup clutch. A water-to-oil type oil cooler is utilized to dissipate heat from the oil supply.

Stall ratio: 2.4:1.

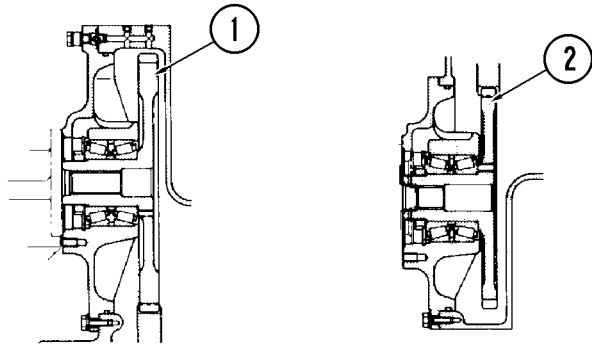

Section V - V

Section W - W

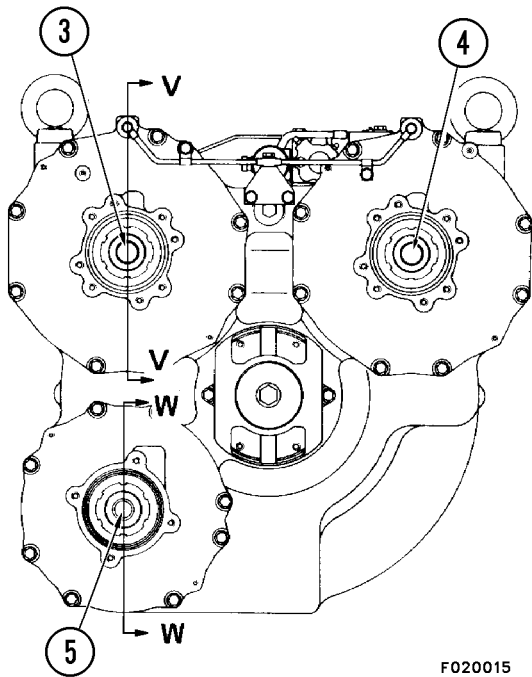

F020015

FIGURE 2-2. TORQUE CONVERTER DRIVE

- | | |
|----------------------------------|--|
| 1. Gear (63 Teeth) | 5. Torque Converter and Transmission Charge Pump Drive |
| 2. Gear (53 Teeth) | |
| 3. Brake Cooling Pump Drive | |
| 4. Steering and Hoist Pump Drive | |

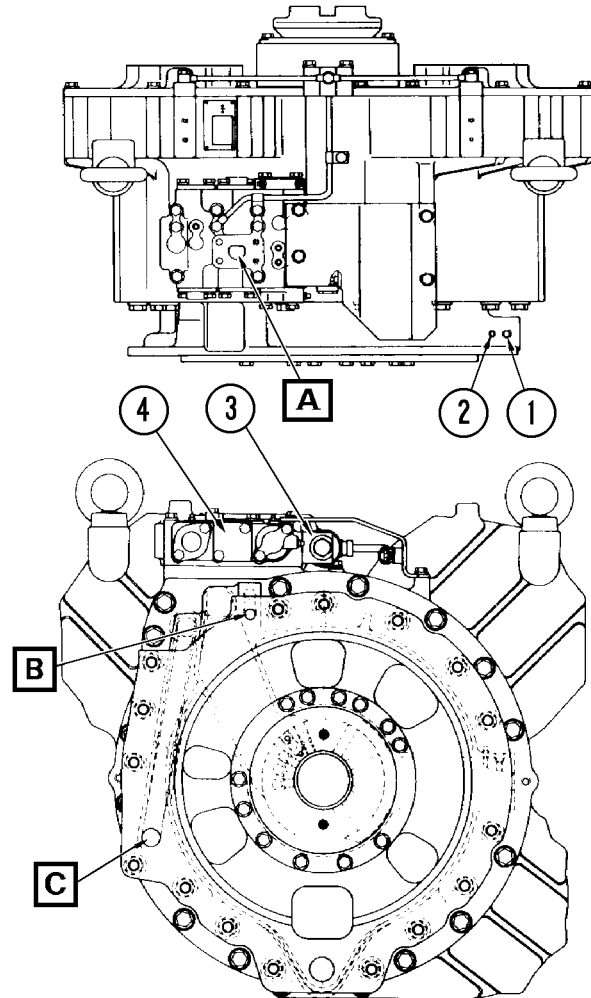

F020016

FIGURE 2-3. TORQUE CONVERTER HOUSING

- | | |
|--|--------------------------------|
| 1. Torque Converter Outlet Temperature Test Port | A. From Pump |
| 2. Torque Converter Outlet Pressure Test Port | B. To Transmission Shift Valve |
| 3. Solenoid Valve | C. To Transmission Lubrication |
| 4. Torque Converter Valve | |

Note: Prior to checking lockup pressure, test and verify main relief pressure is normal.

1. Shut down engine and be certain ignition is Off.
2. Install the shift checker (Refer to Figure 2-21):
 - a. Disconnect the chassis harness (6, Figure 2-21) from the transmission control box (4).
 - b. Connect shift checker harness (3) (white connectors) to the truck chassis harness connectors (SC1, SC2, SC3 & SC4) removed in step a.
 - c. Be certain shift checker power switch is Off. Connect harness (3) black connector to shift checker.
3. Remove plug (4, Figure 2-20). Install a 60 kg/cm² (850 psi) gauge in the port.
4. Start the engine, allow air pressure to build to normal operating range and be certain the parking brake is applied.
5. Turn the shift checker power switch On.
 - a. Press the 4th range shift button.
 - b. With the engine at high idle, press the lockup button to engage the lockup clutch. The hydraulic pressure should be:
 - 16 ± 0.5 kg/cm² (230 ± 10 psi).
6. Press the lockup button again to turn lockup Off.

7. Press the 4th range button again to return to neutral (N). Turn shift checker power switch Off.
8. Shut down the engine and remove the gauge installed in step 3 and replace port plug.
9. If no further tests are to be performed, the shift checker may be removed.
 - a. Disconnect harness connectors (5, Figure 2-21) from chassis harness (6) and remove shift checker.
 - b. Reconnect chassis harness connectors to transmission control box (4).

TORQUE CONVERTER STALL SPEED CHECK

Preparing For Stall Speed Check

Prior to running a stall test, insure that all systems such as exhaust piping, air intake piping, fuel controls, and engine warning systems are all working properly and within specifications. Insufficient fuel or restricted piping can affect stall speed.

The automatic transmission develops high torque in low gear ranges. Therefore, preparations must be made to shift the transmission to the highest gear range available to lower output torque.

This allows the truck service brakes to hold the truck motionless during the stall check procedure.

NOTE: If shift checker 799-607-2000 is to be used on trucks serial number A10190 or higher, harness connector 799-607-2120 must be used. Or, use shift checker 799-607-3000 and connect directly to trucks with serial numbers A10190 & higher.

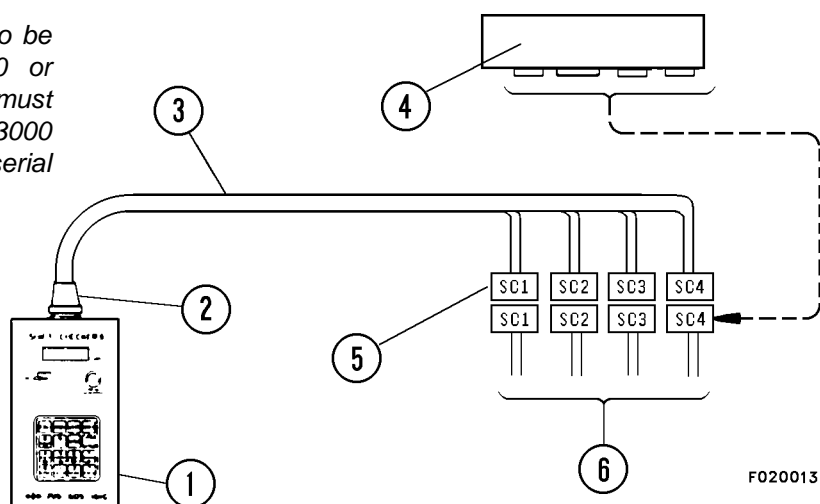

FIGURE 2-21. SHIFT CHECKER INSTALLATION

- | | |
|--|--|
| <ol style="list-style-type: none"> 1. Shift Checker
(Part No. 799-607-2000 or 799-607-3000) 2. Harness connector (to Shift Checker, see NOTE above) 3. Harness Assembly | <ol style="list-style-type: none"> 4. Transmission Control Box 5. Harness connectors (to Chassis Harness) 6. Truck chassis Harness
(Transmission Control Box) |
|--|--|

ECMV Removal

1. Remove the paint along the boundary between the fill switch assembly (16, Figure 2-38) and the valve body (1) at each ECMV to be removed.
2. Disconnect the electrical connectors for the fill switch assembly (16) and solenoid valve (9) from the harness.
3. Remove the switch and solenoid connectors from bracket (18).
4. Remove the transmission oil temperature sensor (4, Figure 2-36) from the filter head and test for proper operation. Refer to Section F6, Sensors, Switches for test procedure and specifications.

Disassembly

1. Before disassembly, flush the ECMV and valve seat (paint at corners of the mating surfaces must be removed thoroughly).

NOTE: Do not allow the solenoid connectors, fill switch connectors, or harness to be exposed directly to the water, etc.

2. Remove the mounting bolts (8, Figure 2-39) from the ECMV assembly (10), and separate the ECMV assembly from valve plate (12).
3. Remove solenoid connector (2, Figure 2-39) and fill switch connector (3) from bracket. Loosen bolts (17). Gently remove the flow sensor valve fill switch (16) and bracket. Be careful not to let spring (15) fall out of place.
4. Remove cover plate (21, Figure 2-38). Remove plug (13) by installing a capscrew in the tapped hole for easier removal. Then, remove the flow detecting valve spring (12), valve spool (11), and spring (15).
 - a. Examine valve body (1) and spool (11) as well as spring (15) for the existence of plating film pieces and other metallic particles. If found, remove them.
 - b. If foreign matter has lodged in the valves or the pistons, or if their functional movement is not smooth, recondition them with an oil stone, etc.
5. Remove spring (6), shims (7), piston (5), and valve (4) from the pressure control valve. Examine for any trapped foreign matter, seized spool, or rough movement. Be careful not to lose shims (7). Keep shims in storage, after confirming their quantity.
6. Remove the proportional solenoid valve (9).

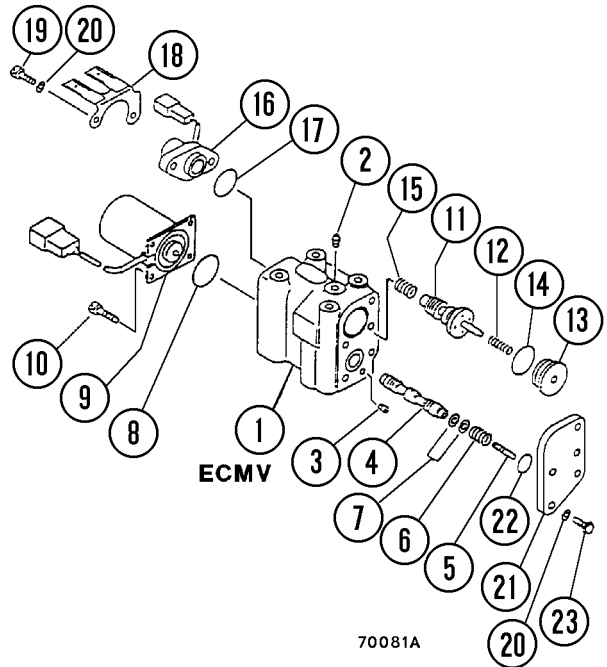

FIGURE 2-38. ECMV ASSEMBLY

1. Valve Body	12. Spring
2. Plug	13. Plug
3. Plug	14. O-ring
4. Pressure Control Valve	15. Spring
5. Piston	16. Fill Switch
6. Spring	17. O-ring
7. Shim	18. Bracket
8. O-ring	19. Bolt
9. Solenoid Valve	20. Washer
10. Bolt	21. Cover Plate
11. Flow Detection Valve	22. O-ring
	23. Bolt

NOTE: Protect the valve plate (12, Figure 2-36) and the valve mating surfaces by applying masking tape, etc. Prevent dirt/dust from entering the transmission by covering all openings. Place all removed parts in storage, being careful not to scratch any part.

**SECTION F3
TRANSMISSION OIL COOLER
INDEX**

TRANSMISSION OIL COOLER	F3-3
Removal And Installation	F3-3
Repair	F3-3
TRANSMISSION STRAINER	F3-3
Removal	F3-3
Installation	F3-3
TORQUE CONVERTER CONTROL VALVE	F3-4
Removal	F3-4
Installation	F3-4
Disassembly	F3-5
Assembly	F3-6

NOTES

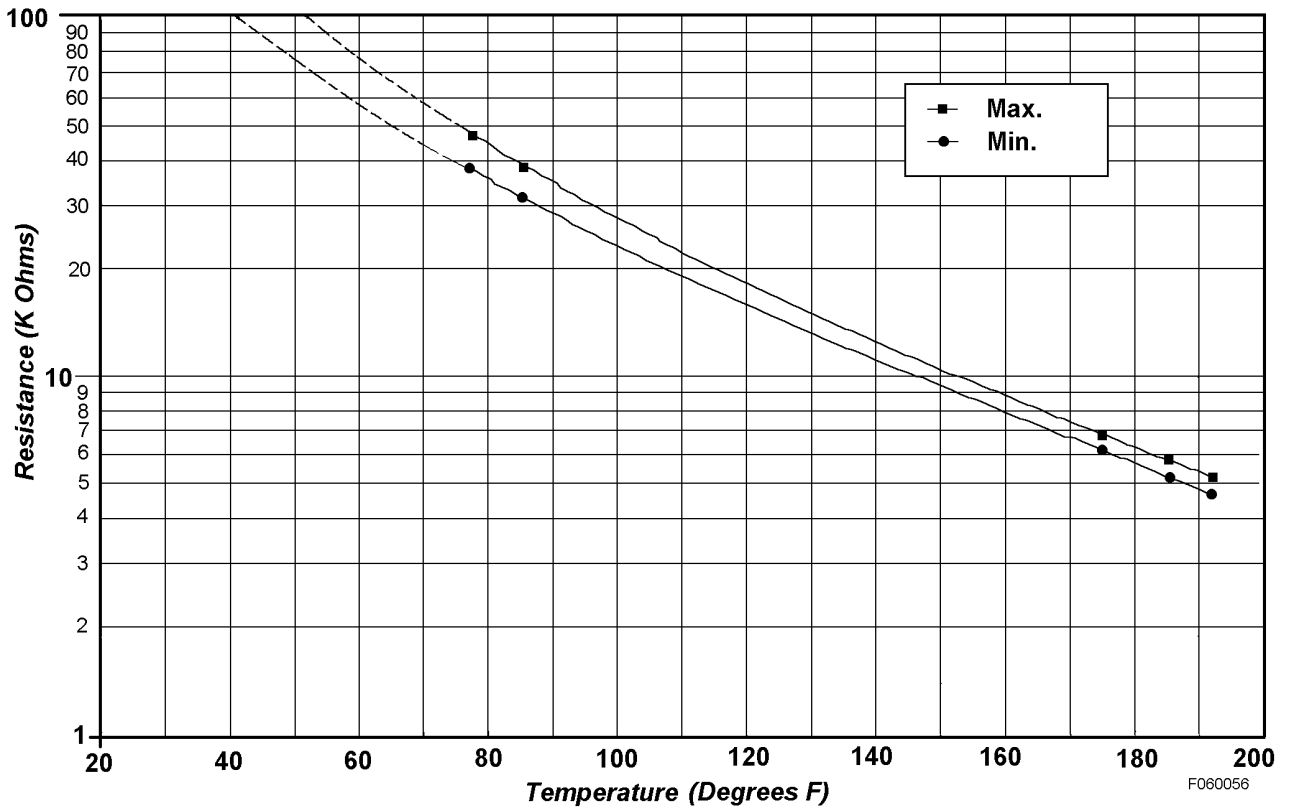
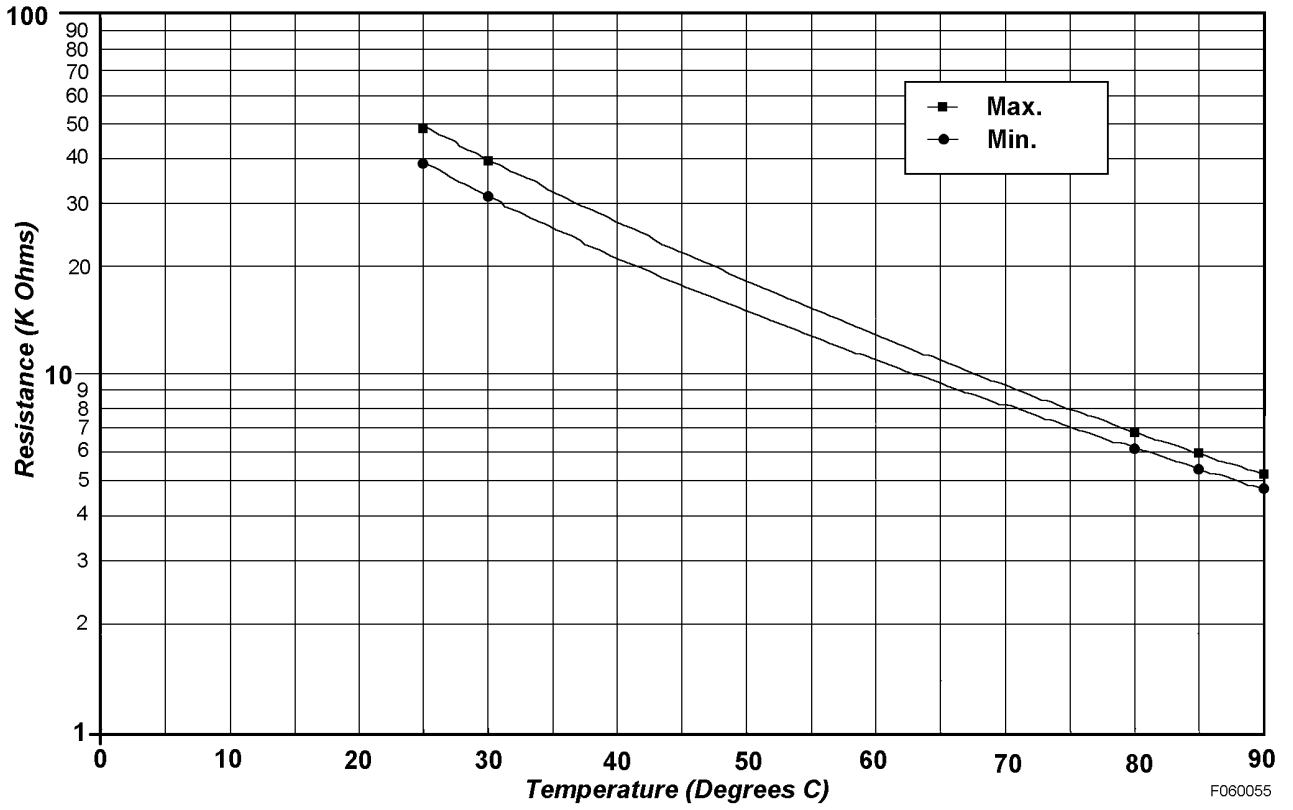

FIGURE 6-12. OIL TEMPERATURE SENSOR CALIBRATION GRAPHS

NOTES

Inspection

1. Inspect all seals and bearings and replace as required.
2. Check seal ring mounting area on wheel hub, brake adaptor and spindle for damage that could cause leakage.
3. Inspect spindle in area of bearing surfaces and radius under spacer for distress or cracks. Non-destructive methods of crack detection (dye penetrant or magnaflux) should be used.

ASSEMBLY OF FRONT WHEEL HUB ASSEMBLY

1. Clean all metal parts in cleaning solvent.
2. Install O-Ring (3, Figure 3-6), spacer (2) and bearing (1).
3. Using a push tool, press outer races (2 and 4, Figure 3-5) into hub.
4. Using a push tool, press fit oil seal (1) into hub.
5. Set brake disc (3) in position on hub. Apply thread tightener Three Bond (TB1374) to the capscrews and attach brake disc to hub. Tighten capscrews to **94.5 ± 10 kg.m (685 ± 72 ft. lbs.)** torque.
6. Support or lift wheel hub with an adequate lifting device and install on spindle.
7. Fill the shaded portion (Figure 3-7) fully with grease shown in Table 1. Approximately 17.5 liters (4.6 gallons) of grease is required for each wheel.

NOTE: Be careful not damage the oil seal on the inside of the hub.

8. Install bearing (1, Figure 3-4).

Table 1: WHEEL BEARING GREASE	
MANUFACTURER	BRAND NAME
Mobil Oil	Mobil Grease HP-2
Showa Shell Oil	Super Duty Grease 2
Esso Oil	Ronex MP

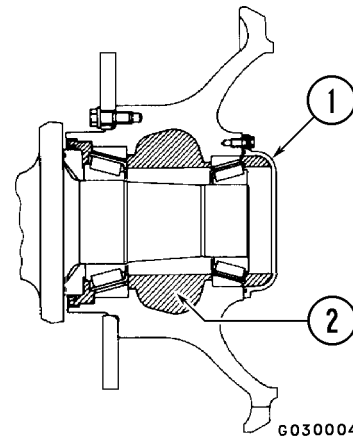

FIGURE 3-7. FRONT WHEEL BEARING

1. Cover
2. Grease Cavity

Front Wheel Hub Bearing Adjustment

1. Install retainer (1, Figure 3-8) with 3 mounting capscrews without installing any shims. Rotate hub 20-30 times and tighten capscrews uniformly to **13.0 ± 0.5 kg.m (94 ± 4 ft. lbs.)** torque.
2. Measure dimension (A) from retainer to tip surface of axle with depth micrometer (2).

NOTE: When removing the retainer, be careful that the bearing does not come out.

NOTE: Measure two places on retainer and take the average.

3. Remove retainer (1), and measure retainer thickness C. Then select shim thickness equal to B ($B=A-C$) + 0.3mm (0.012 in).

NOTE: Select the combination of shims that gives the minimum number of shims.

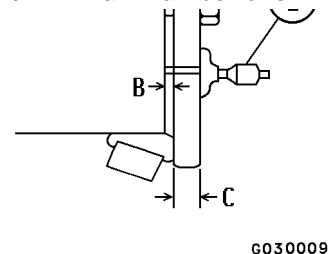

FIGURE 3-8. PRELOAD ADJUSTMENT

1. Retainer
2. Depth Micrometer

NOTES

14. Remove snap ring (2, Figure 5-27), then remove bearing (1) from differential case (3).

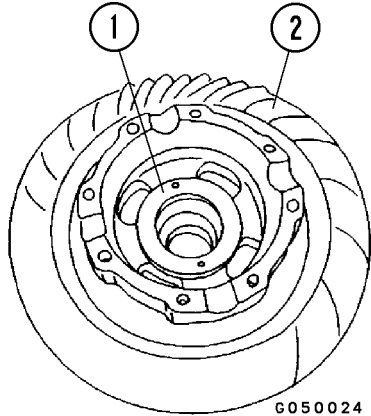

FIGURE 5-25. BEVEL GEAR

1. Thrust Washer 2. Bevel Gear

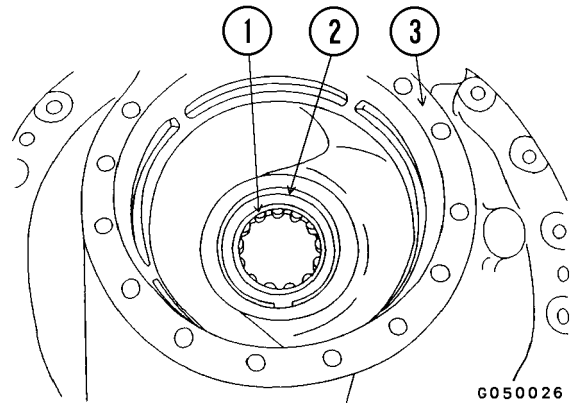

FIGURE 5-27. DIFFERENTIAL BEARING

1. Bearing 3. Differential Case
2. Snap Ring

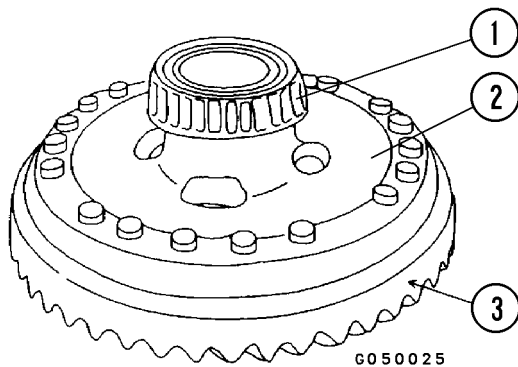

FIGURE 5-26. DIFFERENTIAL BEARING

1. Bearing 3. Bevel Gear
2. Case

ASSEMBLY of DIFFERENTIAL

Differential Bearing

1. Set differential case in tool (2, Figure 5-8). Tool (2) consists of repair stand 790-501-2000 and bracket 790-901-5110.
2. Using a push tool, press bearing (1, Figure 5-27) in differential case (3), and install snap ring (2).

Assembly Of Differential Gear Assembly

1. Install bevel gear (3, Figure 5-26) in differential gear case (2). Apply Three Bond TB1374 thread tightener to mounting capscREW and tighten to **94.5 kg.m (684 ft.lbs.)** torque.
2. Install side bearing (1). Shrink fit bearing by heating to 100° C (212° F).

NOTE: Bearings should be heated by heat lamps, oil bath, or induction heaters. Do not use a torch or heat greater than 176° C (350° F).

NOTE: After bearing cools, check that there is no clearance between the end face of the case and the bearing.

3. Turn case over, then align with dowel pin, and install thrust washer (1, Figure 5-25).

NOTE: Check that the head of the dowel pin is 0.5 +0.2 -0.0 mm (0.02 + 0.0078 - 0.0 in) lower than the surface of the washer.

4. Install side gear (1, Figure 5-24).
5. Differential Pinion Side Gear.

NOTES

SECTION H2
FRONT SUSPENSIONS
INDEX

SUSPENSION SYSTEMH2-3

 SUSPENSION SYSTEM OPERATIONH2-3

 FRONT SUSPENSIONH2-4

 RemovalH2-5

 InstallationH2-7

 SUSPENSION REBUILDH2-8

 DisassemblyH2-8

 InspectionH2-9

 AssemblyH2-9

 ATTENUATION VALVE (FIXED RATE)H2-11

 DisassemblyH2-11

 AssemblyH2-11

NOTES

CLICK HERE TO **DOWNLOAD** THE COMPLETE MANUAL

- Thank you very much for reading the preview of the manual.
- You can download the complete manual from: www.heydownloads.com by clicking the link below



- Please note: If there is no response to CLICKING the link, please download this PDF first and then click on it.

CLICK HERE TO **DOWNLOAD** THE COMPLETE MANUAL

OILING AND CHARGING PROCEDURES

GENERAL

Suspensions which have been properly charged will provide improved handling and a better ride while improving the service life of the truck main frame and suspensions.

NOTE: Inflation pressures and exposed piston lengths are calculated for a normal truck gross vehicle weight (GVW). Any accumulation of dirt/mud/debris on the truck or in the body should be removed before starting these procedures.

Additions to truck weight (tailgates, body liners, water tanks, etc.) should be considered part of the payload. Keeping the truck GVW within the specification will result in a better ride and will extend the service life of the truck main frame and suspensions.

Proper charging of suspensions requires that three (3) basic conditions be established in the following order:

1. Oil level must be correct.
2. Suspension piston rod extension for nitrogen charging must be correct and this dimension be maintained during nitrogen charging.
3. Nitrogen charge pressure must be correct.

For best results, suspensions should be charged in pairs (fronts together and rears together). If rears are to be charged, the fronts should be charged first.

NOTE: Set up dimensions specified in the charts must be maintained during oiling and charging procedures. However, after truck has been operated, these dimensions may vary.

Equipment List

1. Service Kits:
 - a. EC6027 Oil Charging Kit (Figure 4-5)
 - b. EC3331 Nitrogen Charging Kit (Figure 4-6)
2. Jacks and/or Overhead Crane
3. Oil (MIL-L-2104C, SAE 10W)
4. Dry Nitrogen (See Nitrogen Specifications Chart)

NITROGEN GAS SPECIFICATIONS		
	Property	Value
Nitrogen gas used in suspension cylinders must meet or exceed CGA Specification G-10.1 for Type 1, Grade F Nitrogen Gas.	Nitrogen _____	99.9% Min.
	Water _____	32 PPM Max
	Dew Point _____	-55°C (-68°F) Max.
	Oxygen _____	0.1% Max.

⚠ WARNING

All suspensions are charged with compressed nitrogen gas with sufficient pressure to cause injury or damage if improperly handled. Follow all safety notes, CAUTIONS, and WARNINGS in these procedures to prevent accidents during servicing and charging.

FRONT SUSPENSION

1. Park unloaded truck on a hard level surface. Block wheels, apply parking brake.
2. Check that the bottom of the cylinder cover is within the range marked by arrows (Figure 4-1) for correct nitrogen charge.
3. If the suspension is within the area indicated by arrows, no service is necessary for the front suspensions. See "NOTE" below. If suspension is not within the area indicated by the arrows, the front suspensions will have to be serviced.

NOTE: The oil level should be checked:

- Before charging or adding nitrogen.
- When there are signs of oil leakage.
- After rebuild/repair and the suspension is installed on the truck.

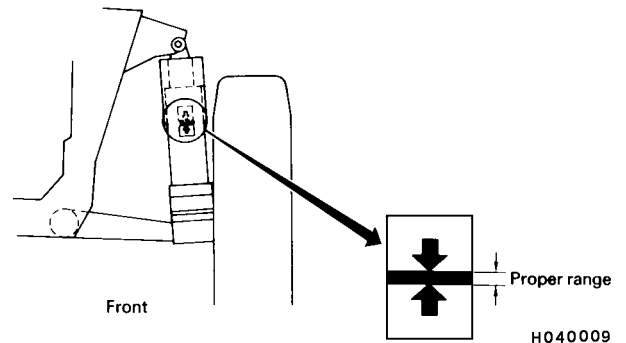

FIGURE 4-1. FRONT SUSPENSION HEIGHT

EMERGENCY BRAKE CONTROL VALVE	J2-19
Function	J2-19
Operation	J2-20
BRAKE VALVE	J2-23
Function	J2-24

Function

□ When brake pedal is depressed (Figure 2-23):

The oil discharged from the brake converter flows into each cylinder (Port B), causing piston (2) to move by stroke d_1 . Thereby, the oil equivalent to stroke d_1 flows out Port A to the brake piston. At this time, no clearance exists between the brake piston and discs, and the braking force does not occur.

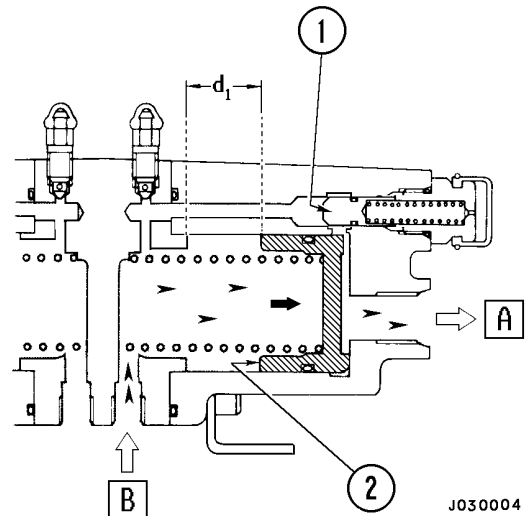

FIGURE 2-23. BRAKE PEDAL DEPRESSED
A. To Brake Piston B. From Converter

□ Adjuster function (Figure 2-24):

Brake apply

When the brake pedal is depressed, oil in a volume equal to stroke d_2 will be discharged out Port A by piston (2). When the oil pressure in the slack adjuster exceeds the pressure limit of poppet valve (1), it opens allowing the pressure oil to flow out Port A. Thereby, the oil pressure is imposed on the brake piston, creating the braking force.

When the brake piston volume is larger than the slack adjuster piston volume.

The oil equal to the shortage in the brake piston volume will be supplied through poppet valve (1) and out Port A, creating pressure in the brake piston chamber. Consequently, the braking effect will be the same as when the brake piston volume and the adjuster volume are equal.

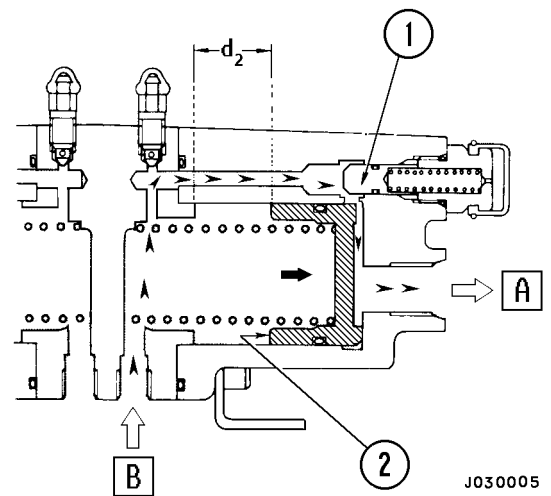

FIGURE 2-24. ADJUSTER FUNCTION

□ When brake pedal is released (Figure 2-25):

When the brake is released, the back pressure is imposed on the brake piston by the brake cooling oil pressure, causing a returning pressure to occur between the adjuster and the brake chamber. Thereby, the piston (1) is moved back by stroke d_3 and the clearance between the disc and the brake piston is kept at a dimension equivalent to the adjuster volume.

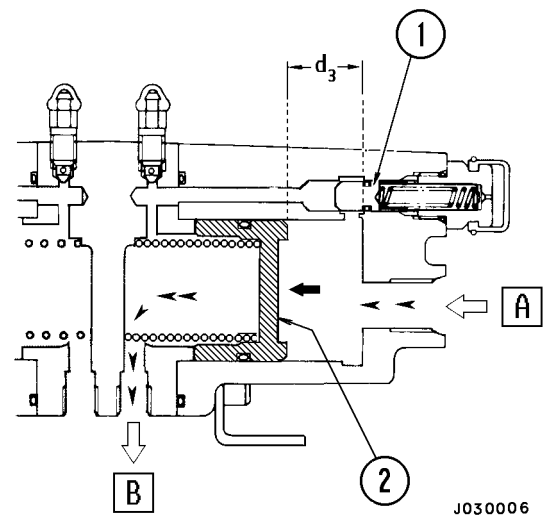

FIGURE 2-25. BRAKE PEDAL RELEASED

Function

A. When brake pedal is being depressed.

When the brake pedal (3, Figure 2-43) is depressed, the pedal movement will be transmitted to the piston (4) through the rubber spring (18), causing the piston (4) to move downward. Then, the exhaust port (E) will be closed and the upper inlet valve (7) will be opened. Thus, the pressurized air from the air reservoir (tank) will flow to the rear brake chamber, causing the application of the rear brake to start.

If the upper inlet valve (7) is opened, the pressurized air will flow to the relay piston (8) through passage (F), pushing inner relay piston (8) downward, which, in turn, will open the lower inlet valve (9).

Then, pressurized air from the air tank will flow to the front brake relay valve to start applying the front brake.

Actually, the force required to move the relay piston (8) is very small and, therefore, there is little difference in timing for the upper and lower inlet valves to begin opening.

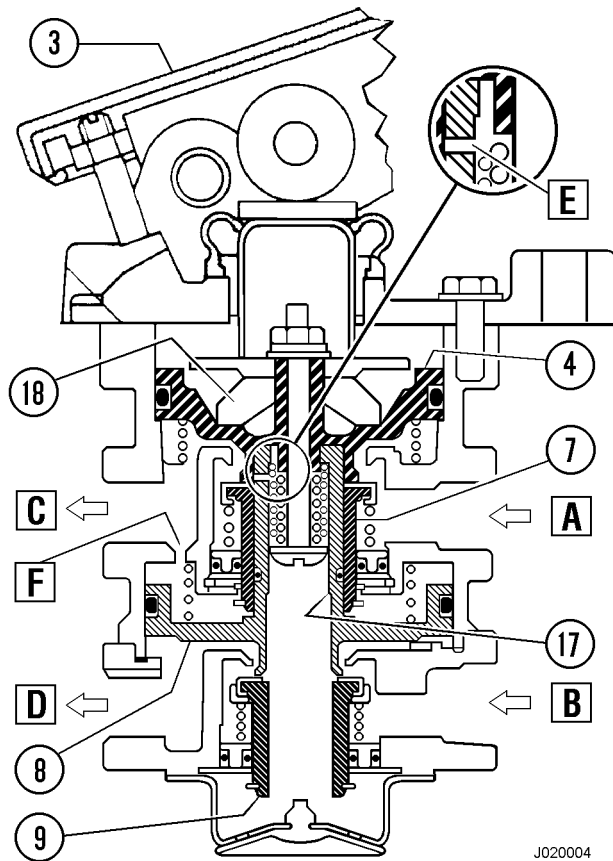

FIGURE 2-43. BRAKE APPLY

- | | |
|------------------------|-------------------|
| 3. Brake Pedal | A: From Air Tank |
| 4. Piston | B: From Air Tank |
| 7. Upper Inlet Valve | C: To Relay Valve |
| 8. Relay Piston | D: To Relay Valve |
| 9. Lower Inlet Valve | E: Exhaust Port |
| 17. Inner Relay Piston | F: Passage |
| 18. Rubber Spring | G: Exhaust Port |

Assembly

NOTE: Assemble all components with line up marks made during disassembly.

Coat the outside diameter of air piston rod (4, Figure 3-13), the cup groove, cup (14) and air cylinder (9), and the inside diameter (sliding part) with a suitable amount of lithium grease.

Coat the outside diameter of oil piston (7), the cup groove, cup (10), the inside diameter of oil cylinder (2), and the inside diameter (cup groove) of cover (14), and 2 cups (18) with a suitable amount of brake system oil.

Cover assembly

1. Install plug (6, Figure 3-18) with Three Bond (TB2411) adhesive and tighten to **2.0 kg.m (14 ft.lbs.)** torque.
2. Install filter (9) and snap ring (8).
3. Assemble bushing (7), secondary cup (2, Figure 3-17 or 3-18), spacer (4), secondary cup (2), cup support (1) and stop ring (5) in order.

Air cylinder assembly

1. Install packing (15, Figure 3-13) to piston and rod assembly (3).



Use 2 or 3 fully threaded capscrews (1, Figure 3-16) with a length below the head of approximately 150 mm (5.9 in.), compress spring (4) uniformly and tighten to install the original capscrews (12, Figure 3-13).

2. Use 2 or 3 fully threaded capscrews (1, Figure 3-16) with a length of approximately 150 mm (5.9 in.) to assemble the air cylinder.
3. Assemble spring (4, Figure 3-16), piston and rod assembly (3), O-ring, and air cylinder (5) to cover assembly (2).
4. Apply Three Bond (TB1374) thread tightener to the six capscrews (12, Figure 3-13) and tighten capscrews to **6.7 kg.m (48 ft.lbs.)** torque.

Oil piston assembly

1. Supply compressed air at 1-2 kg/cm² (14-18 psi) to air cylinder (9, Figure 3-13), and extend piston and rod assembly (3) fully.
2. Install backup ring (11) and seal (10) to oil piston (7).
3. After moving ring (2, Figure 3-14) towards air chamber end, secure bushing guide (4, Figure 3-15) and oil piston (5) to oil piston with mounting pin (3), then install ring (2) to ring groove.
4. Exhaust compressed air from air cylinder.

Oil cylinder

1. Install oil cylinder (2, Figure 3-12) to air cylinder assembly.
2. Tighten capscrews (1) to **3.85 kg.m (28 ft. lbs.)** torque.

Checking

1. Bleed air from oil cylinder.
2. Check that at least 180 kg/cm² (1680 psi) of oil pressure is generated in the oil cylinder when 8 kg/cm² (114 psi) of air pressure is applied to air cylinder.
3. Check that there is no leakage of air or oil.

NOTES

FRONT BRAKES

FRONT BRAKE CALIPER PAD

Removal

1. Refer to Tire Removal, Section G and remove front wheel assembly.
2. Loosen Capscrew (2, Figure 5-1), and pull pin (1) until the pads can be removed.
3. Remove pads (3, Figure 5-2).

NOTE: The brake pads have one end open and the other end closed where the retaining pins hold the pads in place. This allows the removal of the pads without pulling all the pins.

4. Install a vinyl hose to bleeder screw (2) so that the brake oil can be drained out.
5. Loosen the bleeder screw, and return piston (1) to the bottom of the cylinder with a bar. Tighten bleeder screw after oil is bled out and remove vinyl hose.

Installation

1. Install brake pads.
2. Install pin (1, Figure 5-1) and tighten capscrew (2) to **5.25 ± 0.25 kg.m (38 ± 2 ft. lbs.)** torque.
3. Bleed the air from the brake circuit. Refer to Brake Bleeding this Section.

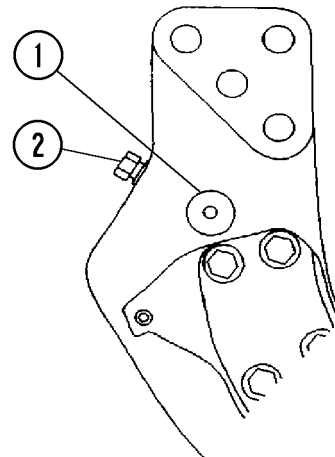

J050006

FIGURE 5-1. BRAKE PAD REPLACEMENT

1. Pin 2. Capscrew

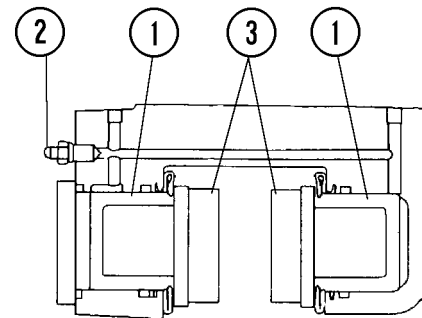

J050007

FIGURE 5-2. BRAKE PAD REPLACEMENT

1. Piston 3. Brake Pads
2. Bleeder Screw

BRAKE CALIPER ASSEMBLY

Removal

1. Refer to Tire Removal, Section G and remove front wheel assembly.
2. Disconnect the two brake lines (1, Figure 5-3).
3. Remove 13 mounting capscrews (3, Figure 5-4). Use a suitable lifting device as support, remove the remaining mounting capscrews, and remove caliper assembly.

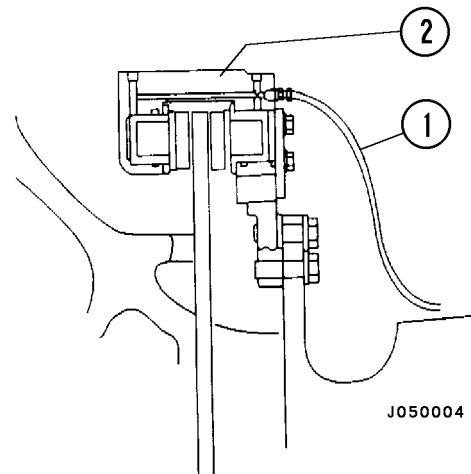

J050004

FIGURE 5-3. BRAKE CALIPER

1. Brake Lines 2. Caliper Assembly

NOTES

SECTION K
AIR SYSTEM
INDEX

AIR SYSTEM..... K2-1

AIR SYSTEM COMPONENT REPAIR K3-1

RETARDER VALVE K5-1

NOTES

**SECTION K5
RETARDER VALVE
INDEX**

RETARDER VALVE	K5-3
RETARDER FUNCTION	K5-3
Removal	K5-3
Installation	K5-3
Disassembly	K5-5
Assembly	K5-5

Tank

The hydraulic tank is mounted to the left frame rail. It is separated into two sections. One for steering and hoist the other for the wet disc brake cooling oil. The service capacity for the steering and hoist section is 162 liters (42.8 gal.) and for the rear brake cooling section is 268 liters (70.8 gal.).

NOTE: The oil recommended for use in both sections of the hydraulic tank (steering/hoist and brake cooling) is A.P.I. classification CD SAE-10W engine oil.

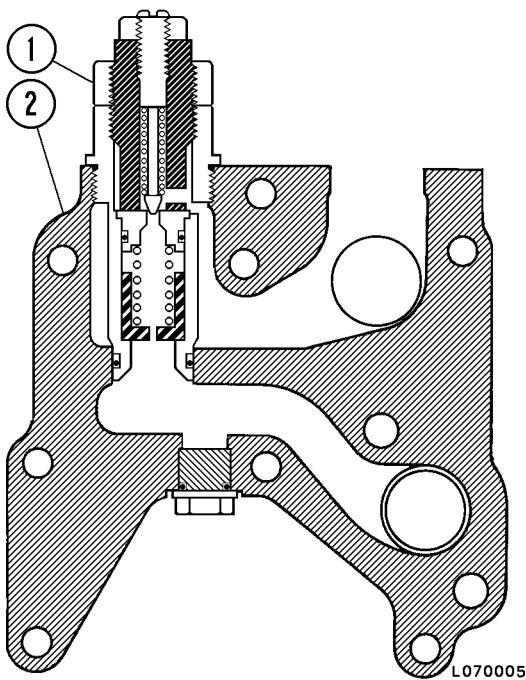

FIGURE 2-1. HOIST RELIEF VALVE

1. Relief Valve 2. Housing

Oil returning to the hydraulic tank from the steering and hoist circuit passes through a 30 micron filter assembly. The oil from the brake cooling circuit passes through two 30 micron filter assemblies. These filters are accessible by removal of a cover plate for each filter.

The oil level should be checked periodically with the body down, engine stopped and parked on level ground.

Refer to Lubrication and Service Section P for additional information regarding hydraulic system service intervals, capacities and oil specifications.

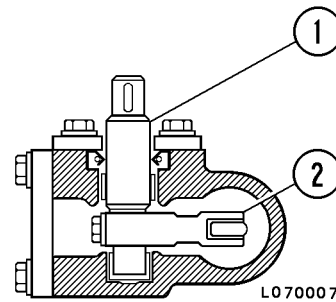

FIGURE 2-2. HOIST VALVE LINKAGE

1. Shaft 2. Lever

**SECTION L4
STEERING CIRCUIT
INDEX**

STEERING CIRCUIT L4-3

 STEERING CIRCUIT OPERATION L4-3

 DEMAND VALVE L4-4

 STEERING CONTROL VALVE L4-4

 CROSSOVER RELIEF VALVE L4-5

 OPERATION OF DEMAND AND STEERING CONTROL VALVE L4- 6

 EMERGENCY STEERING SYSTEM L4-14

 Flow Switch L4-15

 Operation L4-15

 Relay Timer L4-15

DEMAND VALVE: When in emergency steering mode.

STEERING CONTROL VALVE: When in emergency steering mode.

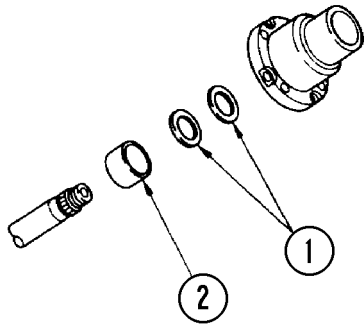

L050014

FIGURE 5-14.

1. Shims 2. Spacer

11. Remove upper cover assembly from input shaft and valve spool assembly, then remove shim (1, Figure 5-14) and spacer (2).

NOTE: Check the number and thickness of the shims, and keep in a safe place.

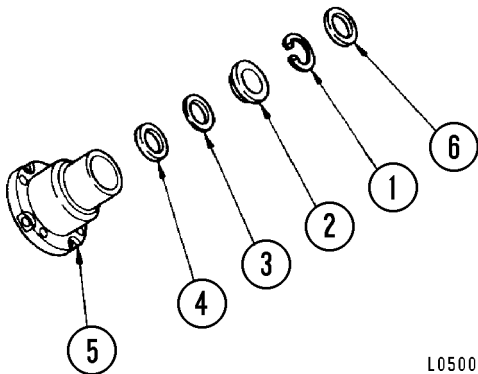

L050016

FIGURE 5-15.

1. Snap Ring 4. Seal Ring
2. Spacer 5. Upper Cover
3. Seal

12. Remove seal (6, Figure 5-15) and snap ring (1), then remove spacer (2), seal (3), and seal ring (4) from upper cover (5).

NOTE: Seal (3) and seal ring (4) may be combined into one piece.

13. Remove snap ring (1, Figure 5-16), thrust washer (2), thrust bearing (3), thrust washer (4), and wave washer (5) from input shaft (6).

14. Using a punch (1, Figure 5-17) 3.0 mm dia., x 16 mm long (0.12 in. dia. x 0.62 in. long), remove pin (2, Figure 5-18) from input shaft.

NOTE: To prevent damaging the input shaft, carry out the operation on a wooden block.

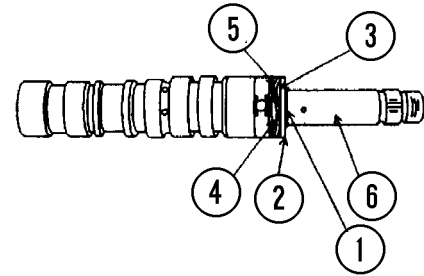

L050017

FIGURE 5-16.

1. Snap Ring 4. Thrust Washer
2. Thrust Washer 5. Wave Washer
3. Thrust Bearing 6. Input Shaft

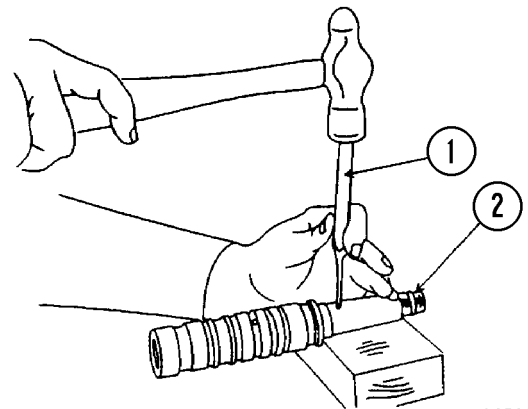

L050019

FIGURE 5-17. PIN REMOVAL

1. Punch 2. Input Shaft

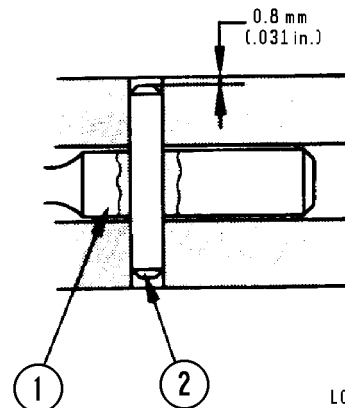

L050020

FIGURE 5-18. PIN DETAIL

1. Shaft 2. Pin

NOTES

SECTION L7
HOIST CIRCUIT OPERATION AND COMPONENT DESCRIPTION
INDEX

HOIST CIRCUIT OPERATION AND COMPONENT DESCRIPTION L7-3

 HOIST CIRCUIT OPERATION L7-3

 HOIST CIRCUIT COMPONENT DESCRIPTION L7-3

 Hoist Cylinders L7-3

 Hydraulic Filter L7-3

 Hoist Valve L7-3

 RAISE L7-4

 HOLD L7-5

 POWER DOWN L7-6

 FLOAT L7-7

Disassembly

1. Remove main relief valve assembly (1, Figure 8-3).
2. Loosen nut (2), and remove screw (3), then remove retainer (4), spring (5), and poppet (6).
3. Loosen nut (7), and remove holder (8) and seat (9).
4. Remove snap ring (10), then remove retainer (11), valve (12), and spring (13) from sleeve (14).
5. Remove tube (15).
6. Remove case (16), and bolts (17), then remove detent (18), collar (19), retainer (20), spring (21), and retainer (22).
7. Remove valve control case assembly (23).
8. Remove cover (24), then loosen bolt (25), move lever (26), and remove key (27).
9. Remove plate (28), then remove dust seal (29), oil seal (30), shaft (31), and bearing (32) from case (33), and pull out spool (34).
10. Remove plate (35), and seat (36), then remove spring (37) and valve (38) from valve body (39).

Assembly

1. Insert valve (38) and spring (37) in valve body (39), then fit O-ring and assembly seat (36). Coat surface of plate (35) with Loctite and install.

NOTE: Coat the parts in step 2. with Mobil Grease 77 or equivalent lubricant prior to assembly:

2. Press fit bearing (32), oil seal (30), and dust seal (29) in case (33).
3. Insert shaft (31), assemble key (27) and lever (26), then align position of notch in spool (34) with lever (26), and secure with bolt (25).
4. Coat surface of plate (28) and cover (24) with Loctite and install.
5. Insert spool (34). Coat surface of valve control case assembly (23) with Loctite and install.
6. Assemble retainer (22), spring (21), retainer (20), collar (19), and detent (18), then tighten bolt (17) to standard torque.
7. Coat mating surface of case (16) with Loctite. Fit O-ring and install case (16).
8. Install tube (15). Tighten tube bolts to **3.75 Kg.m (27 ft. lbs.)** torque.
9. Assemble spring (13), valve (12), and retainer (11) in sleeve (14), then fit snap ring (10) and

install seal (9), holder (8), and nut (7). Tighten nut (7) to standard torque.

10. Install poppet (6), spring (5), retainer (4), screw (3), and nut (2).
11. Install main relief valve assembly (1).

FIGURE 8-3. HOIST VALVE ASSEMBLY

1. Main Relief Valve Assembly
2. Nut
3. Screw
4. Retainer
5. Spring
6. Poppet
7. Nut
8. Holder
9. Seat
10. Snap Ring
11. Retainer
12. Valve
13. Spring
14. Sleeve
15. Tube
16. Case
17. Bolt
18. Detent
19. Collar
20. Retainer
21. Spring
22. Retainer
23. Valve Control Case Assembly
24. Cover
25. Bolt
26. Lever
27. Key
28. Plate
29. Dust Seal
30. Oil Seal
31. Shaft
32. Bearing
33. Case
34. Spool
35. Plate
36. Seat
37. Spring
38. Valve
39. Valve Body

ADJUSTING HOIST LIMITER

1. Adjust push cable (1, Figure 10-5) to the standard length A.

Standard length A: 180.25 mm (7.09 in)

2. With the dump body raised to a point 50 mm (1.96 in) before the end of the hoist cylinder stroke, adjust plate (2, Figure 10-6) so that the hoist valve lever is released from the detent.

Reference dimension B: 147 mm (5.79 in)

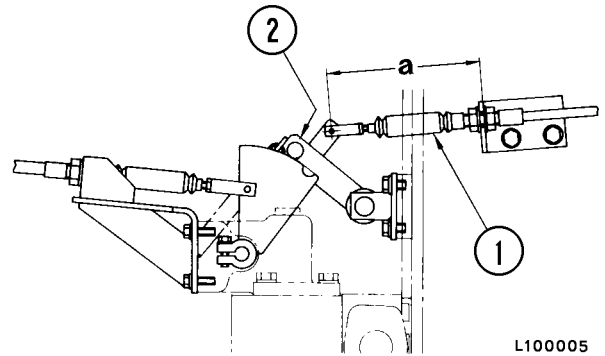

FIGURE 10-5. LINKAGE ADJUSTMENT

1. Cable A: 180.25 mm (7.09 in)
2. Linkage

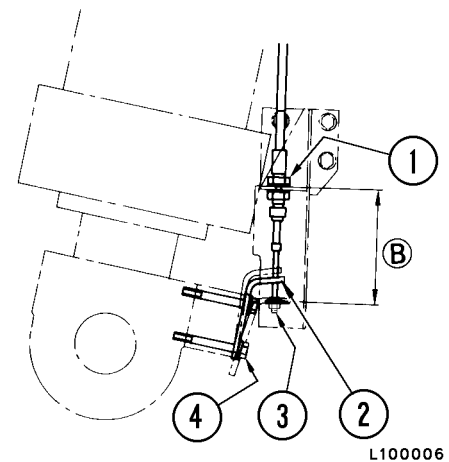

FIGURE 10-6. HOIST LIMIT PLATE

1. Adjusting Nuts B: 147 mm (5.79 in)
2. Plate
3. Attaching Nut
4. Capscrew

NOTES

MAINTENANCE

The fan drive system requires a minimum of maintenance. A few simple checks made periodically will assure correct operation and long life.



Observe all safety precautions when working in the area of the fan. If working with a running engine, the fan will come on automatically without warning when engine temperature rises.

Maintenance Checks To Be Made

1. Fan bracket to engine bolts: Check torque after first week of operation and every 500 hours thereafter.
2. Fan-to-fan mounting hub bolts: Check torque after first week of operation and every 500 hours thereafter.
3. Fan belts: Maintain proper belt tension. Refer to Section C for belt tension adjustment.
4. Hoses and fittings: Check all hoses and fittings every 500 hours. Replace all soft, brittle or frayed hoses. Tighten all loose or leaking fittings.
5. Thermal sensor(s): Check corrosion buildup on thermal tip after each 5000 hours. Clean if necessary and check for proper operation.

DO NOT DISASSEMBLE OR DISTURB THERMAL SENSOR SETTING.

6. Electrical: All electrical connections should be checked for tightness after each 5000 hours. All electrical harnesses should be checked for breaks and frays. Check to insure all grounding points are intact.
7. Thermostat: The engine thermostat operation should be checked according to engine manufacturer's specifications and recommendations.
8. Fan clutch: After each 1000 hours, the fan clutch should be checked for signs of internal wear as follows:
 - a. Bearing wear: With the engine off and no oil supply to the fan clutch, push the fan forward-rearward. No movement of the fan mounting hub should occur.

NOTE: For the next tests, it is necessary to provide an external supply of oil pressure at 275 KPa (40 psi) minimum, 689 KPa (100 psi) maximum. The oil supply should be compatible with the oil being used in the engine.

- b. Clutch Plate Drive Slot Wear: With the engine off and the clutch locked up, rotate the fan with a light force clockwise-counter-clockwise. Movement at the tip of a fan blade should not exceed 22.4 mm (0.88 in.). Excess movement indicates excessive wear at the drive tangs.
- c. Clutch Plate Wear: With the engine off, apply 275 kPa (40 psi) oil pressure to lockup the clutch. Using a pull type scale connected to the fan blade 610 mm (24 in.) from the center of fan, a pull of no less than **712 - 756 N (160 - 170 lbs.)** should be required to rotate the blade independent of the pulley.

10. Setup front bearing retainer assembly on a press as shown in Figure 6-16. Place assembly on supports which will allow hub to drop out of front ball bearing.

- a. Remove woodruff keys (1).
- b. With tool (2) positioned on fan hub and complete assembly under ram, press hub assembly out of front bearing.

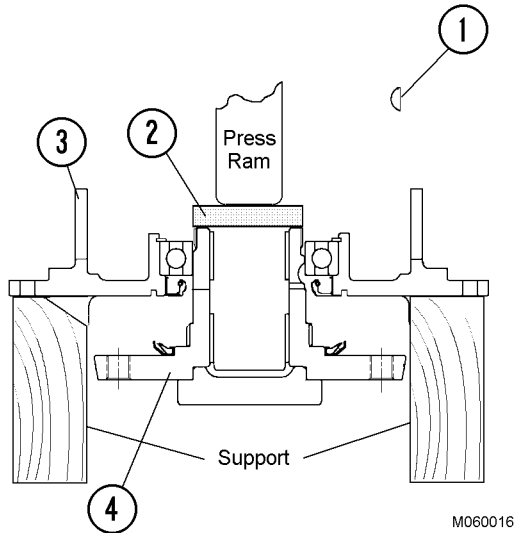

FIGURE 6-16. FAN MOUNTING HUB REMOVAL

- | | |
|------------------------------|------------------------------|
| 1. Woodruff Key | 4. Fan Mounting Hub Assembly |
| 2. Tool #4 | |
| 3. Bearing Retainer Assembly | |

12. Setup front bearing retainer on a press with supports under the retainer and spaced to allow bearing to drop out of bore as shown in Figure 6-18.

- a. Place tool # 2 on front bearing (2).
- b. Place tool # 5 on top of bearing removal tool and press bearing out.

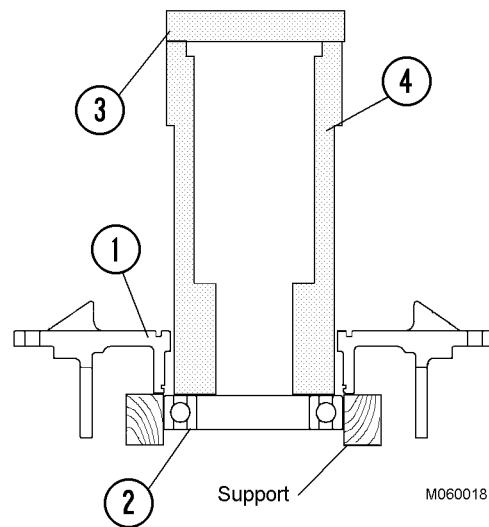

FIGURE 6-18. FRONT BEARING REMOVAL

- | | |
|---------------------|------------|
| 1. Bearing Retainer | 3. Tool #5 |
| 2. Front Bearing | 4. Tool #2 |

11. Disassemble front bearing retainer.

- a. Remove snap ring (1, Figure 6-17).
- b. Use a punch to drive the front oil seal (3) out of the bearing retainer bore.

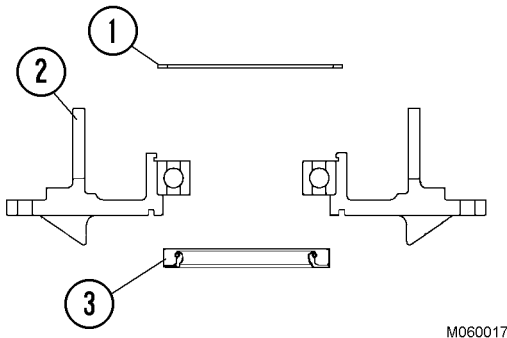

FIGURE 6-17. FRONT BEARING RETAINER DISASSEMBLY

- | | |
|---------------------|-------------|
| 1. Snap Ring | 3. Oil Seal |
| 2. Bearing Retainer | |

13. Sleeve Bearing Inspection: Refer to Figure 6-19 and compare appearance of I.D. of the sleeve bearings in the bore of the fan mounting hub with the illustrations. If the bearings require replacement, proceed to step 14. If not, go to step 17.

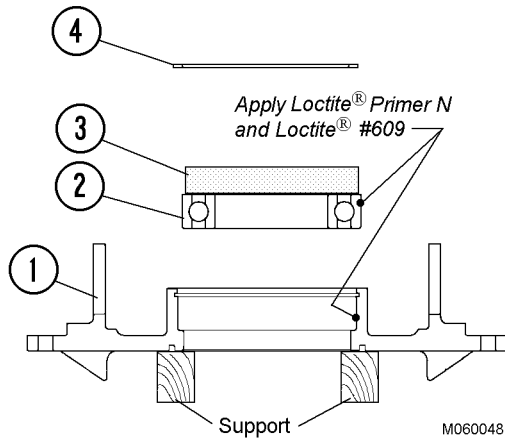

FIGURE 6-48. FRONT MAIN BEARING INSTALLATION

- | | |
|-----------------------------|-----------------------|
| 1. Bearing Retainer (Front) | 3. Tool #5 |
| 2. Bearing | 4. Internal Snap Ring |

7. Setup the bearing retainer (1, Figure 6-48) on supports as shown.
 - a. Apply Loctite® Primer N to bearing (2) outer race and bore of bearing retainer.
 - b. Apply Loctite® #609 to above parts.
 - c. Using tool #5, press bearing to bottom of the bore in the retainer.
 - d. Install snap ring (4).

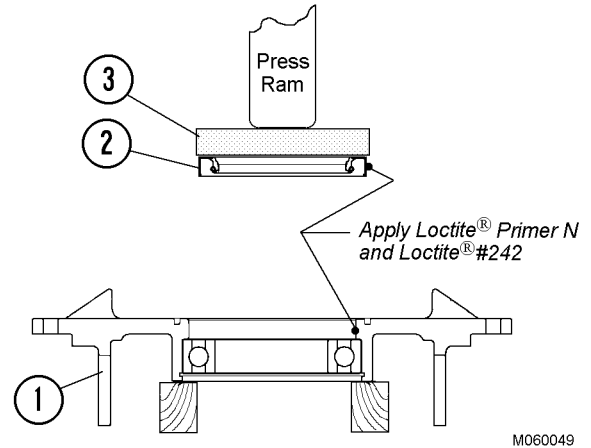

FIGURE 6-49. FRONT OIL SEAL INSTALLATION

- | | |
|-----------------------------|---------------------|
| 1. Bearing Retainer (Front) | 2. Oil Seal (Front) |
| 3. Tool #5 | |

8. Remove front bearing retainer from press bed and invert as shown in Figure 6-49. Place supports under bearing bore area.
 - a. Apply Loctite® Primer N to O.D. of oil seal (2) and bore in bearing retainer.
 - b. Apply Loctite® #242 to above parts.

▲ IMPORTANT ▲

The seal lip must remain dry. DO NOT allow Loctite® to contact seal lip.

- c. Position seal over bore and place tool #5 centered over seal.
- d. Press seal into bore until tool contacts face of bearing retainer. (Seal will be flush and straight with face of bearing retainer.)
- e. After seal is installed, wipe off excess sealant and remove rubber "strings" created when seal was pressed into bore.

Tool #3
Retainer/Seal Assy. Installer

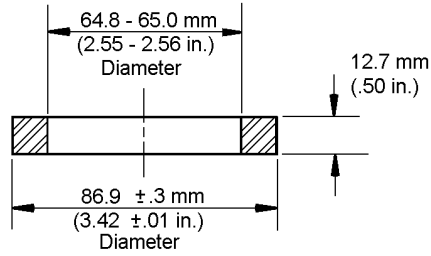

Tool #4
**Fan mounting hub & shaft
 assy. remover plate**

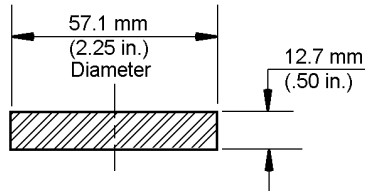

Tool #5
Bearing & seal installation

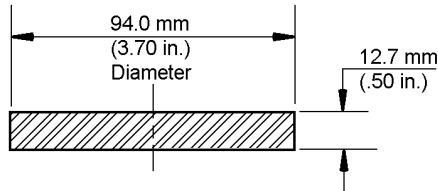

Tool #6
**Clutch body assy.
 holding fixture**

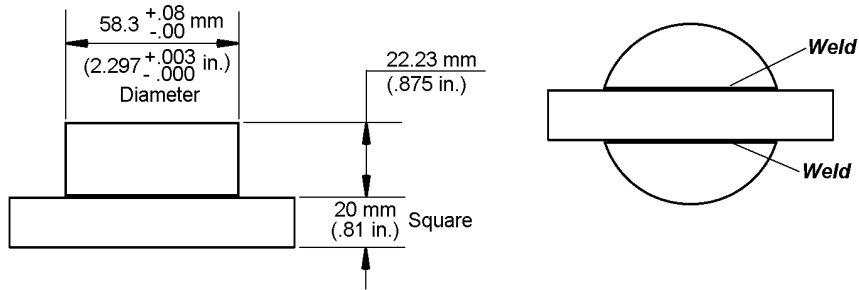

TOOL #7
**Fan mounting hub removal
 and installation**

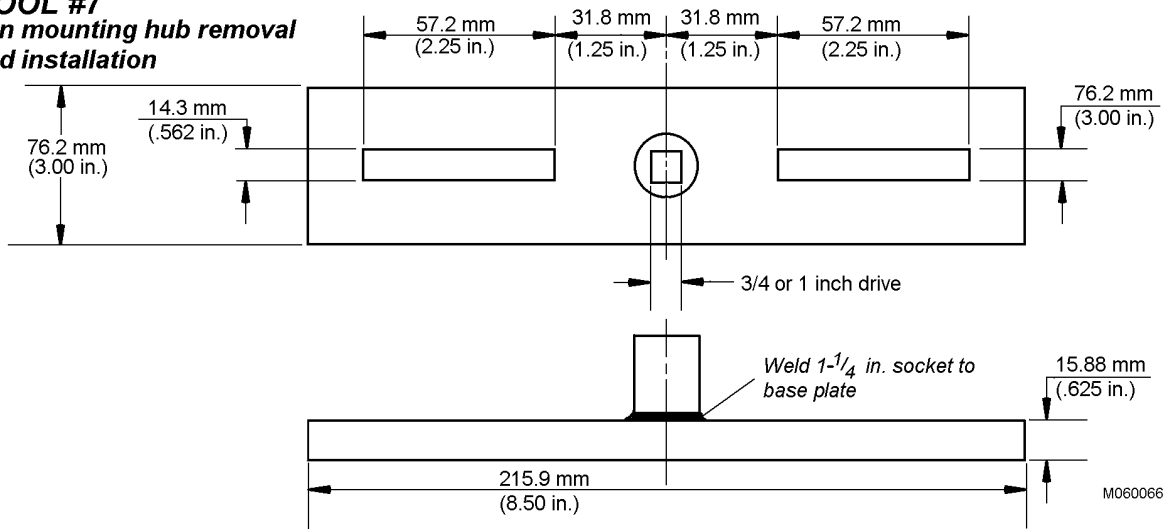

SECTION G		
PART NUMBER	DESCRIPTION	USE
792-520-2110	Small Installer	Floating Seals in Final Drive
791-585-1510	Large Installer	
792-520-2110	Small Push Tool	Use With Installers Above
791-585-1510	Large Push Tool	

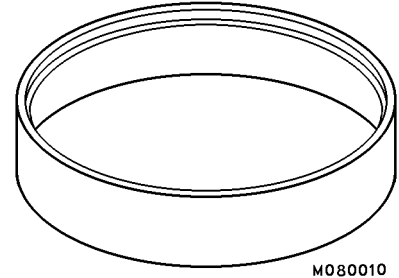

M080010

SECTION G		
PART NUMBER	DESCRIPTION	USE
792-525-3000	Micrometer	Differential Preload

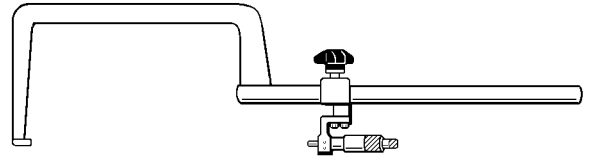

M080011

SECTION G		
PART NUMBER	DESCRIPTION	USE
790-425-1660	Wrench	Differential Preload

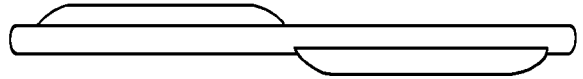

M080012

LIGHTS, SWITCHES AND COMPONENTS On The Face Of The Payload Meter (Refer to Figure 20-1)

1. Display Panel

Digital display area for the data being recorded in memory. This will include items such as:

- Payload
- Date & Time
- Cycles
- Travel Distance
- Fault Codes and Warnings

2. Reception Pilot Lamp (Rx Busy)

This light will illuminate for 3 seconds when the system is powered up. It will then be lit whenever the computer is communicating.

3. Transmission Pilot Lamp (Tx Busy)

This light will illuminate for 3 seconds when the system is powered up. It will then be lit whenever the memory is being downloaded to a personal computer.

4. Memory Card Access Lamp (CARD Busy)

This light will illuminate for 3 seconds when the system is powered up. It will also be lit whenever the memory data is being downloaded to the memory card.

5. Mode Switch

This switch is used to select the mode or system that will allow a function to be performed. This may include:

- Various settings or corrections to the display
- Memory card downloading
- Clearing data
- Display of Abnormalities or Warnings
- Setting the speed limit
- Setting the date and time

6. Calibration/Clear Switch

Used to calibrate the machine when the conditions regulate this action. Also used with the TOTAL/SFT switch to clear total payload and overall number of cycles.

7. Total/Shift Switch

Used to display payload and overall number of cycles each time the load is dumped. Will display the error codes. This switch is also used with the CALIBRATION/CLEAR switch to clear total payload and overall number of cycles.

8. Light/Increment Switch

Used to change the digital increments or units for the various displays. Also used to adjust the brightness of the lights on the monitor display.

9. Memory Card

Used to receive data from the payload meter memory to this card which can then be used to transfer the data into a personal computer. This enables the memory to be downloaded and saved when a personal computer is not available.

10. Cover









Protective cover for the Memory Card. Do not open or place foreign objects in slot.

11. Diagnostic/Download Port

Connector port that is used for downloading the memory data to a personal computer.

Checking the Operator Check Mode

The Operator Check Mode is used to check and change several settings. These should be checked before the payload meter is put into service.





1. Press and hold the MODE switch. The display will show: 
2. Press the MODE switch once. The display will show: Refer to "Data All Clear" to clear the haul cycle data. 
3. Press the MODE switch once. The display will show: Refer to "Display of Fault Codes" for viewing fault codes. 
4. Press the MODE switch once. The display will show: This is the truck ID number. Refer to "Setting The Machine ID" to change Machine ID. 
5. Press the MODE switch once. The display will show: 
Refer to "Setting The Operator ID" to change operator.
6. Press the MODE switch once. The display will show: 
"SP:62" should be displayed. The speed limit should be set to 62 to avoid unnecessary faults and warnings. Refer to "Setting The Speed Limit" to make adjustments.
7. Press the MODE switch once. The display will show: 
Refer to "Setting The Option Code" to change the option.
8. Press the MODE switch once. The current time should be displayed with the minutes flashing. Refer to "Setting The Time And Date" to change the time and date. 
9. Push the MODE switch to return to normal operation.

Checking the Service Check Mode



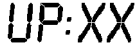

▲ IMPORTANT ▲

Refer to page 24 for additional information on UP Factor and PL Mode prior to setting these values.

Setting "UP:XX"

1. Press and hold the LIGHT/INC and MODE switches. The display will show: 
2. Press and hold the LIGHT/INC and TOTAL/SFT switches. The display will show: 
3. Press the CAL/CLR switch once. The display will show: 
4. Press the LIGHT/INC switch until "XX" is set to the desired gain ($\pm 9\%$).
5. Press MODE. The display will show: 
6. Press MODE and the meter will return to normal operation.

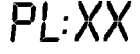
Setting "PL:00"

1. Press and hold the LIGHT/INC and MODE switches. The display will show: 
2. Press and hold the LIGHT/INC and TOTAL/SFT switches. The display will show: 
3. Press the CAL/CLR switch once. The display will show: 
4. Press the CAL/CLR switch once. The display will show: 
5. Press the LIGHT/INC switch until "PL:00" is displayed. **ONLY PL:00 IS RECOMMENDED.** 
6. Press the MODE switch. The display will show: 
7. Press MODE and the meter will return to normal operation.

FINAL GEAR RATIO SELECTION

For an 830E truck, the proper gear ratio has to be selected.

1. Press and hold the MODE and LIGHT/INC switches until "CHEC" **CHEC** is displayed.
2. Press and hold the TOTAL/SFT and LIGHT/INC switches until "S.SEL" is displayed. **S.SEL**
3. Press the CAL/CLR switch repeatedly until "A.XX" is displayed, where "XX" is one of the following: **A.XX**

"XX"	Gear Ratio	Remarks
00	31.875	Original
01	36.400	High Traction
02	28.125	Standard
03	26.625	High Speed

NOTE: The Payload Meter is originally set to "00".

4. Press the TOTAL/SFT switch and "XX" will flash.
5. Press the LIGHT/INC switch to select the desired gear ratio.
6. Press the MODE switch and "CHEC" will be displayed. **CHEC**
7. Press the MODE switch and the meter will return to normal operation.

FAULT TREE DIAGNOSIS

Payload Lights Won't Illuminate

The load lights are illuminated for 5 seconds after the keyswitch is turned ON. The load lights are powered through a 15A breaker on relay board 2 (RB2). The Light Control Relay (LCR) is activated by a ground signal through the brake lock switch. The brake lock switch must be closed to complete the circuit through the LCR relay and power the load lights. Each light color is controlled by a relay on RB2. Each load light relay coil is grounded through the payload meter to activate the light. There is one relay for each color light.

If the load lights do not illuminate during loading, verify the brake lock is being used at the loading site. Verify that the lights illuminate when the keyswitch is turned ON. If not, check the 15A circuit breaker and the LCR relay, first. Then, check the brake lock signal to the relay board. Ensure that the connections to the relay board are solid.

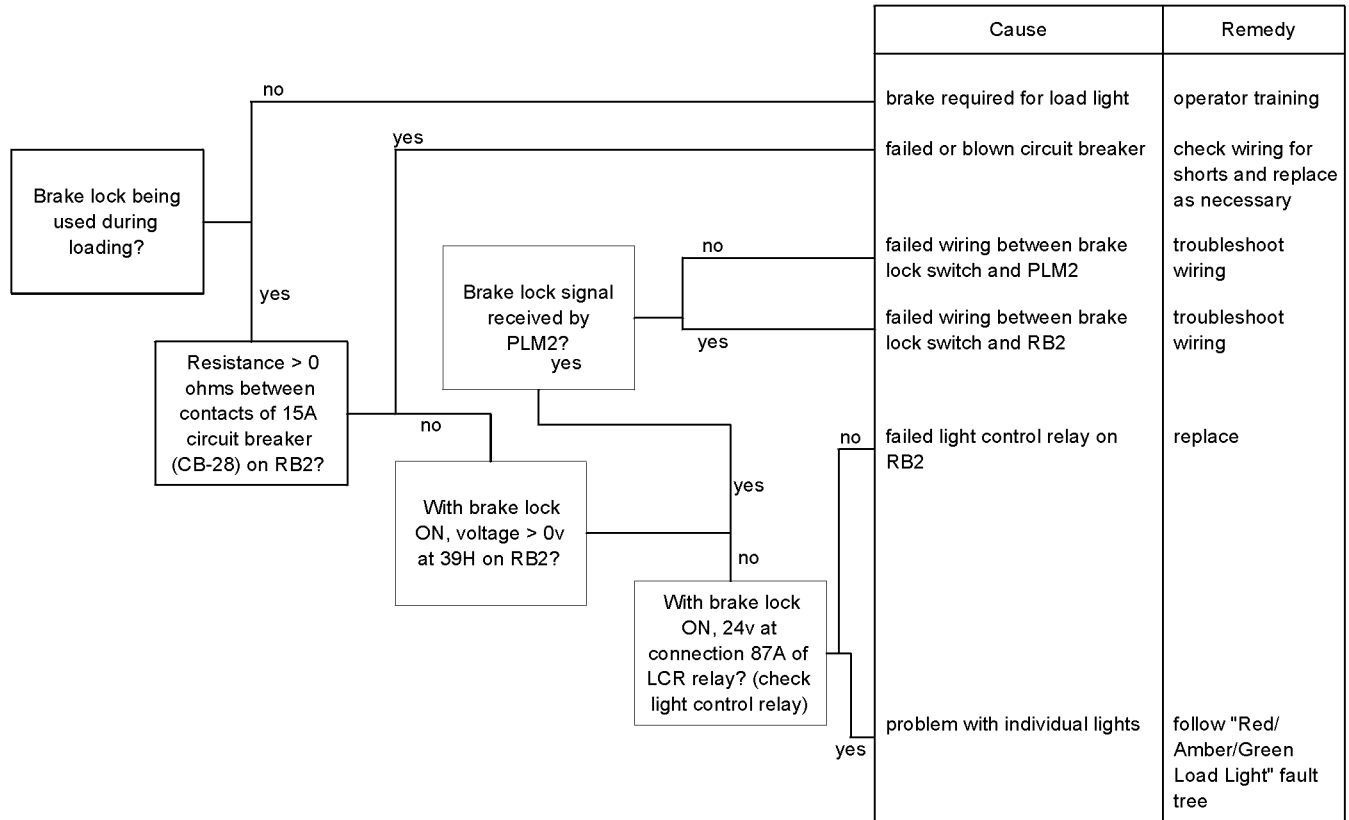

M200056

Body Up Input

The body up signal is critical to proper payload meter operation. The payload meter starts a new haul cycle when the body comes down from dumping the last load. If the payload meter cannot sense the body up and down, it will not begin recording haul cycles.

Confirm that the dashboard indicator for body-up is working properly. If not, check the connections at the body up switch. This switch is a magnetic reed switch. The switch may fail or the plate that triggers the switch may be misaligned. Refer to the appropriate shop manual for the proper procedure for adjusting the switches.

NOTE: The input to the payload meter is 'live' and can be checked by raising and lowering the body or using a large washer to trigger the switch.

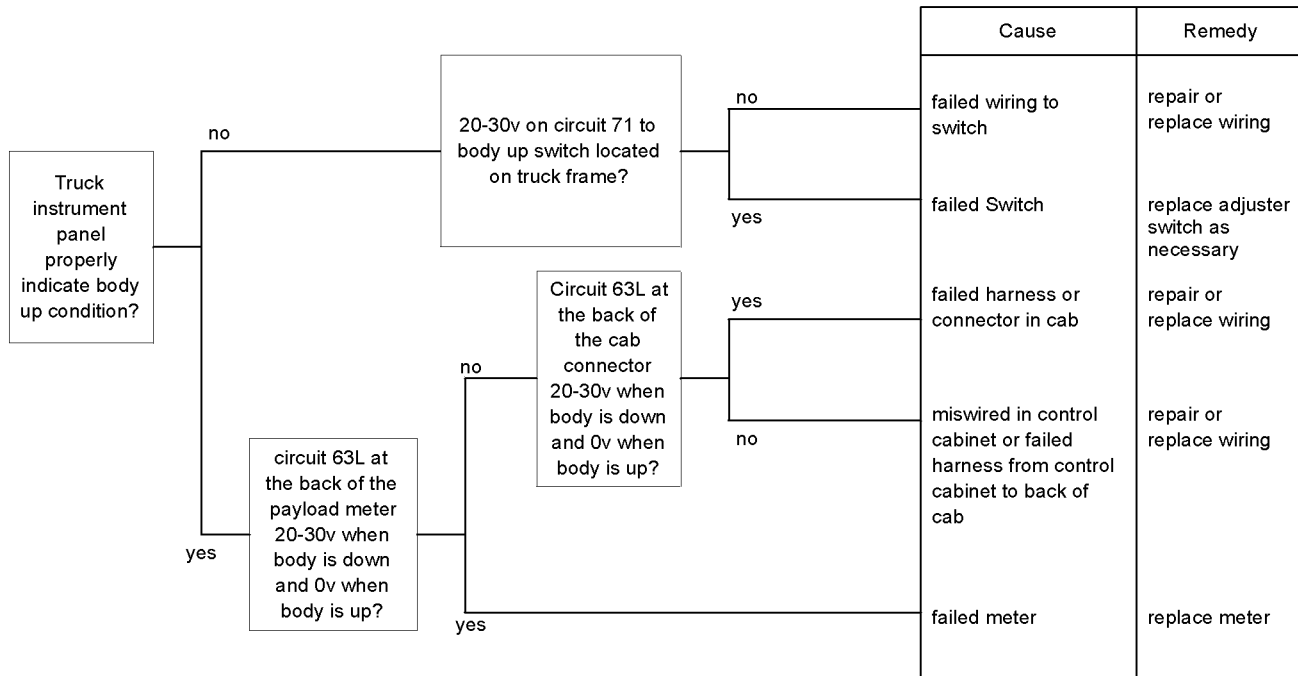

M200064

All data is comma separated and can be imported into most popular spreadsheets and data analysis programs. A typical file looks like this:

9:40:27	R	4	458.21	439.71	283.18	247.6	1.28	22	2	0	1	1	1
9:40:27	R	4	465.32	448.25	278.91	246.18	1.04	22	2	0	1	1	1
9:40:28	R	4	456.78	451.09	274.64	247.6	1.33	22	2	0	1	1	1
9:40:28	R	4	443.98	465.32	276.06	256.14	2.14	23	2	0	1	1	1
9:40:28	R	3	432.59	445.4	277.49	261.83	2.61	23	2	0	1	1	1
9:40:28	R	3	436.86	424.05	278.91	256.14	2.99	24	2	0	1	1	1
9:40:29	R	3	461.05	421.21	288.87	251.87	2.61	24	2	0	1	1	1
9:40:29	R	2	486.67	421.21	286.02	241.91	1.52	24	2	0	1	1	1
9:40:29	R	2	483.82	415.52	288.87	251.87	1.85	25	2	0	1	1	1

In the sample data shown, the column marked "Type" refers to the type of data being transmitted; "R" is used for Real-Time, "F" is used for Final Load and "S" is used for Swing Load.

For the swing load data line the format is Time, S, Swing Load, Predicted Load, FL, FR, RL, RR.

For a final load transmission the format is Time, F, Final Load, FL, FR, RL, RR.

Connections to Payload Meter II™

Two harnesses are required to connect a PC to the Payload Meter II™.

- EF9159 - Connects to the back of the Payload Meter II™ to a panel mount connector.
- EF9160 - Connects from the panel mount connector to the PC.

The connectors and pins typically used for the payload meter connection are :

Description	Part Number
Terminal	7827101440
Connector	7845253670

The Payload Meter requires 5 wire RS232 communications. Payload Meter communications connections are :

1 - RTS **2** - Signal Ground **3** - RxD **4** - TxD **5** - CTS

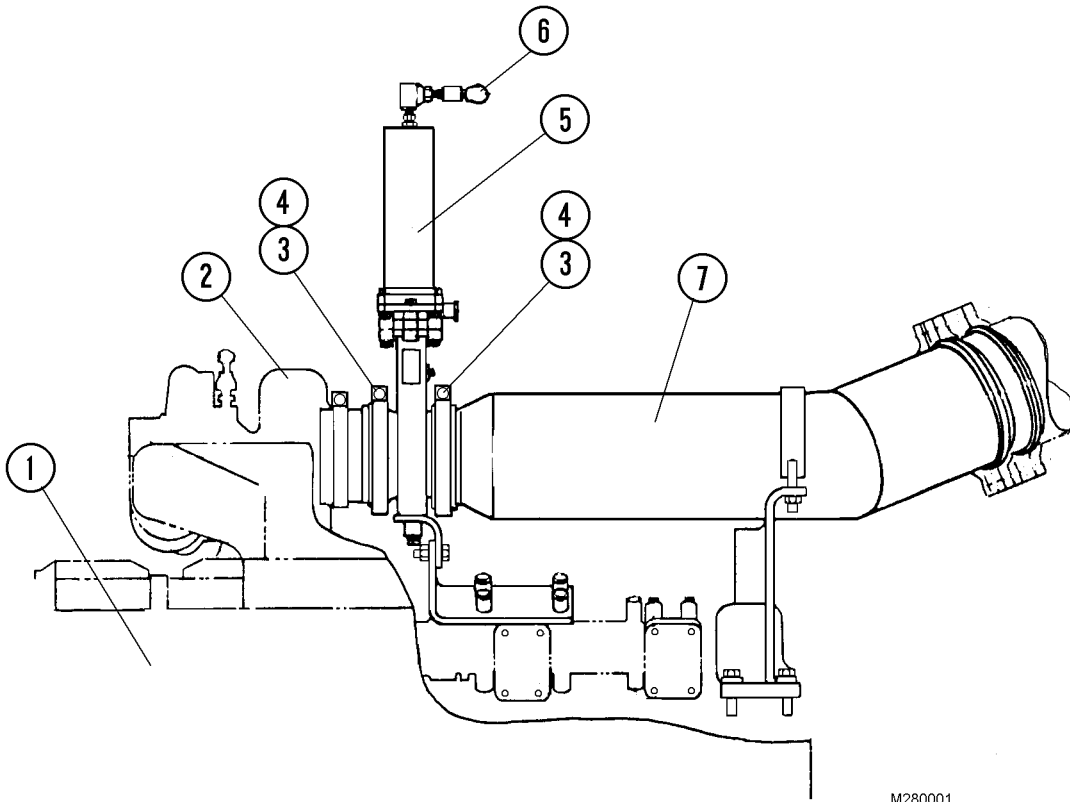

M280001

FIGURE 28-6. EXHAUST BRAKE INSTALLATION
(Left Side Shown, Right Side Typical)

- | | | |
|-----------------|---------------------------|-----------------|
| 1. Engine | 4. Gasket | 7. Exhaust Pipe |
| 2. Turbocharger | 5. Exhaust Brake Assembly | |
| 3. Band | 6. Air Supply Fittings | |

Exhaust Brake Assembly

The exhaust brake cylinder/valve units (5, Figure 28-6) are installed at the outlet of the right and left turbochargers.

When the exhaust brake system is activated, air from the solenoid valve enters the port (6) at the top of each cylinder. When the piston moves down, it closes a valve plate blocking the flow of exhaust gas, creating an engine braking effect.

When the system is de-activated, air is exhausted out the solenoid valve exhaust port, releasing air pressure inside the cylinder. An internal spring returns the piston to the top of the cylinder, opening the valve plate and allowing exhaust gasses to flow through the exhaust pipes (7) and into the atmosphere.

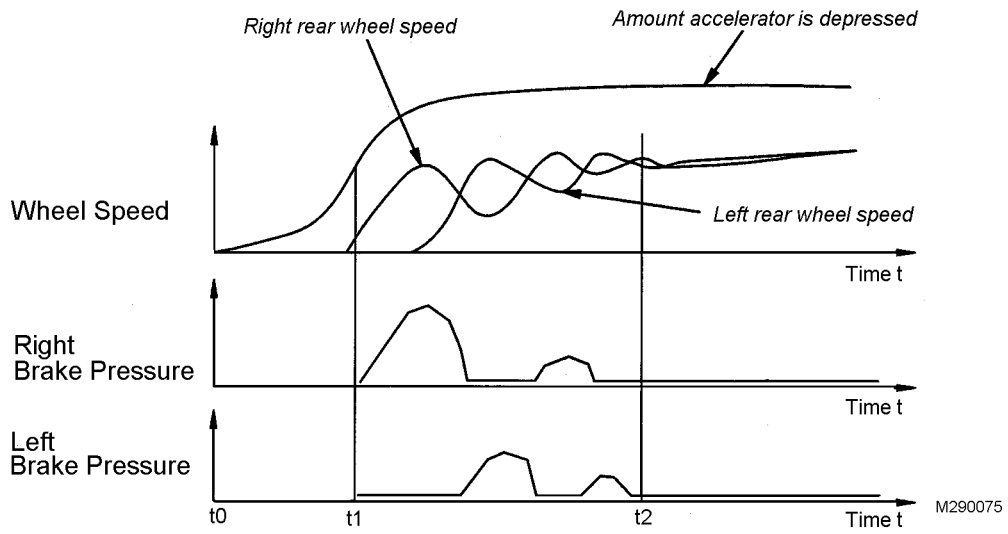

FIGURE 29-3. CONTROLLER OPERATION GRAPH

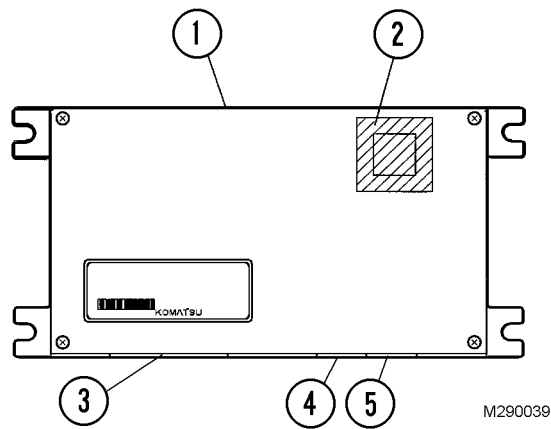
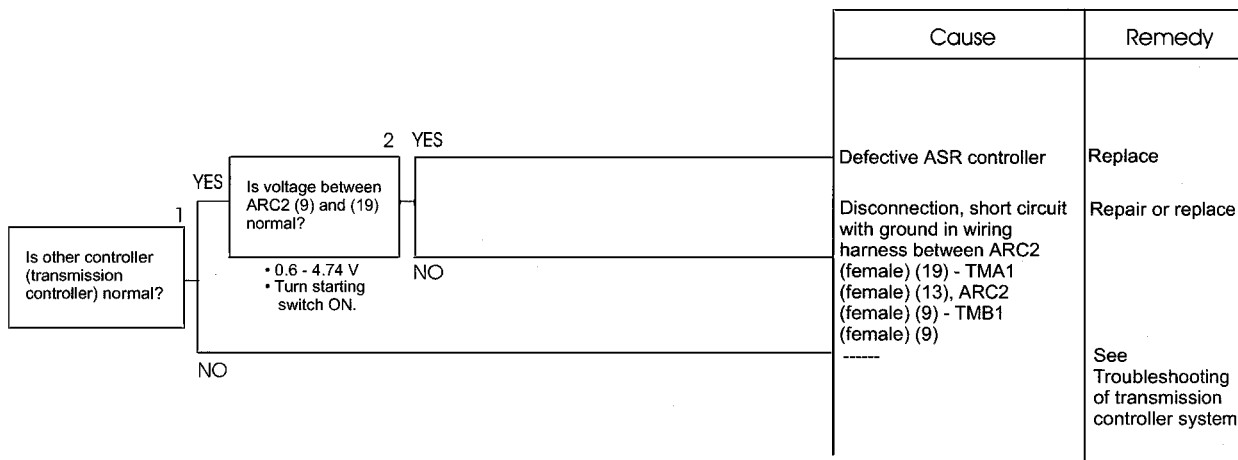

FIGURE 29-4. ASR/ARSC CONTROLLER

- | | |
|------------------------------|---------------------|
| 1. Controller Housing | 4. Connector (ARC2) |
| 2. Fault Code Display Window | 5. Connector (ARC3) |
| 3. Connector (ARC1) | |

AS-7: Fault Code 1.7 Accelerator signal system fault

1. Troubleshooting is performed while the fault is being generated. When the connector is disconnected and the T-adaptor is inserted, or when the T-adaptor is removed and the connector reinstalled, if the error code is no longer displayed, then the system has been reset.
2. Before troubleshooting, be certain all connectors are properly inserted.
3. Always connect any disconnected connectors before proceeding to the next step.
4. The controller monitors the electrical circuits for any open or shorted to ground circuits in the acceleration sensor signal circuits.



AS-7 Related electrical circuit diagram

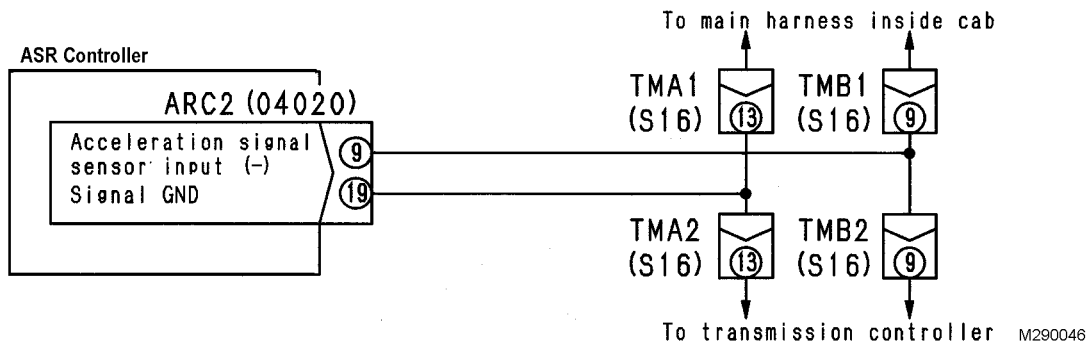

AS-18: Fault Code 8.3 Right pressure control valve system, open circuit

1. Troubleshooting is performed while the fault is being generated. When the connector is disconnected and the T-adapter is inserted, or when the T-adapter is removed and the connector reinstalled, if the error code is no longer displayed, then the system has been reset.
2. Before troubleshooting, be certain all connectors are properly inserted.
3. Always connect any disconnected connectors before proceeding to the next step.
4. The controller monitors for an open circuit between the controller and pressure control valve.
5. Check controller connector (ARC1) to connector (BRJ1), to connector (BSOR), then check pressure control valve in that order.

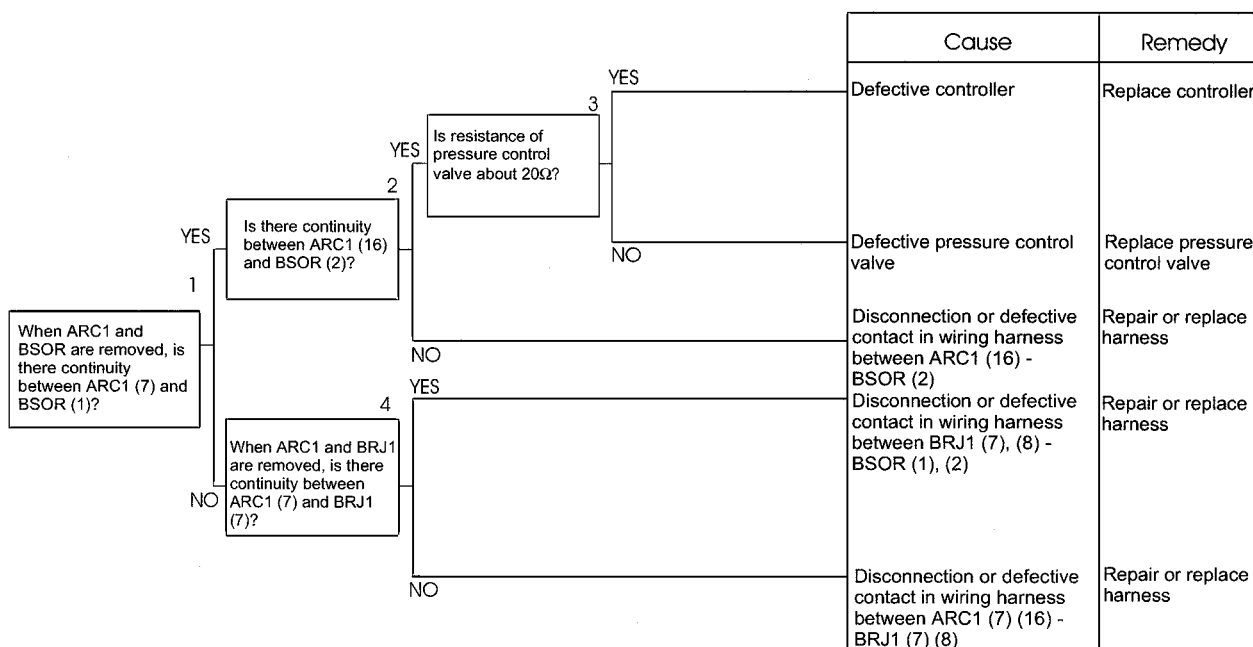

AS-18 Related electrical circuit diagram

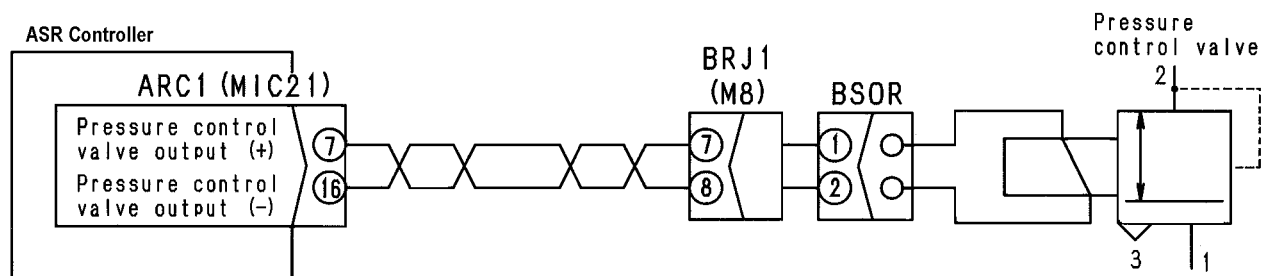

M290057

AS-103 : Another controller has failed

1. Before troubleshooting, be certain all connectors are properly inserted.
2. Always connect any disconnected connectors before proceeding to the next step.
3. The ASR system is connected into the standard truck electrical system using T-branch connectors. Verify all T adapters are properly installed.

Transmission Controller System

1. Failure in accelerator sensor
 - Check wiring harness between TMA1 pin 13 and TMA2 pin 13.
 - Check wiring harness between TMB1 pin 9 and TMB2 pin 9.
2. Failure in transmission output shaft speed sensor
 - Check wiring harness between TMA1 pins 1, 2 and TMA2 pins 1, 2.
3. Failure in engine speed sensor
 - Check wiring harness between TMD1 pins 13, 14 and TMD2 pins 13, 14.
4. Other failures
 - Check wiring harness between TMA1 and TMA2, TMB1 and TMB2, and TMC1 and TMC2
5. Engine speed is abnormal
 - Check wiring harness between TMD1 pins 13, 14 and TMD2 pins 13 and 14.

Payload Meter System

1. Failure in payload meter system
 - Check wiring harness between ARC3 pin 6 and PM4-1 pin 5.

AUTOMATIC RETARD SPEED CONTROL SYSTEM (ARSC) TROUBLESHOOTING

The optional Automatic Retard Speed Control System (ARSC) is supplied in combination with the Automatic Spin Regulator (ASR) system. Both systems use the same controller to provide operational functions and share some components such as the ASR/ARSC system caution lamp used to detect problems in either system. The controller is equipped with self-diagnostic features to aid the technician in troubleshooting problems if they occur.

If the system controller detects a fault, the Central Warning lamp, alarm buzzer, and the ASR/ARSC caution lamp will activate to inform the operator that a problem exists. In addition, the controller will display and store in memory, a fault code which can help the technician diagnose a system problem and determine if the problem has occurred in the ASR system or in the ARSC system.

Note: This section of the manual describes troubleshooting procedures for the ARSC system only. Since some components of the ARSC system are also used by the ARS system, it may be necessary to refer to ASR (Automatic Spin Regulator) System, in this section of the manual for additional information and tests.

PRELIMINARY TROUBLESHOOTING PROCEDURES

1. Before troubleshooting, the technician should try to repeat the conditions under which the fault occurred to determine if the fault will occur again.

Note: Failures in the electrical system circuits may be caused by defective wiring, terminals, or wiring harness connectors and may occur due to vibrations when the truck is operating at higher speeds or operating on rough haul roads etc. Therefore, it is necessary to try to duplicate the operating conditions when the failure occurred. This is especially important when the source of the problem cannot be determined when the truck is parked and the engine is shut down.

2. If the problem appears to be caused by an electrical system failure, carefully check the appropriate circuit harness connectors for improper connection, damage or contamination due to oil, water etc. Check wiring harnesses for damage due to abrasion, proximity to high tempera-

ture components (exhaust system) or mechanical damage from debris or improper routing.

3. Verify the system is not affected by radio or other electrical equipment in use. It may be necessary to systematically disable suspected equipment and try to repeat the failure occurrence. If such a component is determined to cause the problem, modify the equipment or mounting location to eliminate the interference.
4. Always read and follow any precautions noted prior to performing system checks.

Troubleshooting Specific Problems

The Fault Code Table that follows is used to determine what component or circuit in the ASR/ARSC system may be causing a problem based on the fault code observed on the controller display window.

- Fault codes specifically related to the ARSC system only are noted in the "Applicable System" column. Instructions for troubleshooting these codes appear on page M30-7 through M30-55.
- Fault codes that are common to both the ASR and ARSC system are noted in the "Applicable System" column. Instructions for troubleshooting these codes appear on page M30-7 through M30-55 however, it may also be necessary to refer to Section M, ASR System Troubleshooting for additional information.
- Fault codes specifically related to the ASR system only are noted in the "Applicable System" column. To troubleshoot these codes, refer to Section M, ASR System Troubleshooting.

When troubleshooting individual circuits in the ARSC system, refer to Table I, Fault Codes for the appropriate failure code displayed or the nature of the fault, then consult the detailed troubleshooting steps indexed in the "Index Code" column

Follow the troubleshooting steps in sequence and be certain all test conditions are observed (key switch ON or OFF, harness installed or disconnected etc.). After the suggested component(s) is replaced, repeat the troubleshooting steps to ascertain the problem has been corrected.

R-8: Fault Code 4.2 Exhaust brake selector signal, open circuit

1. Troubleshooting is performed while the fault is being generated. When the connector is disconnected and the T-adaptor is inserted, or when the T-adaptor is removed and the connector reinstalled, if the error code is no longer displayed, then the system has been reset.
2. Before troubleshooting, be certain all connectors are properly inserted.
3. Always connect any disconnected connectors before proceeding to the next step.
4. The controller monitors for open electrical circuits in the exhaust brake selector signal system.

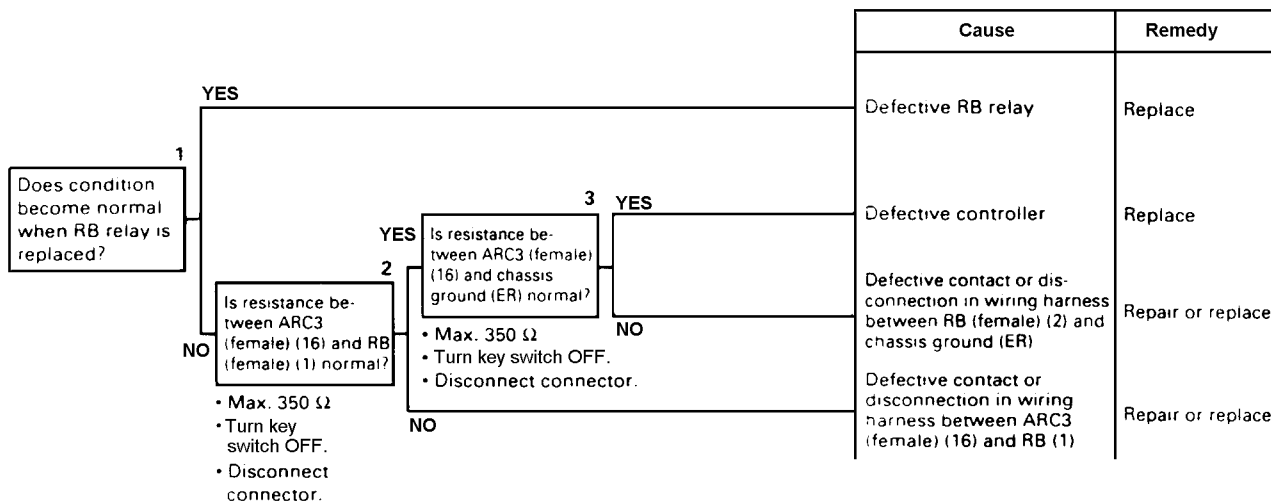

R-8 Related Electrical Circuit Diagram

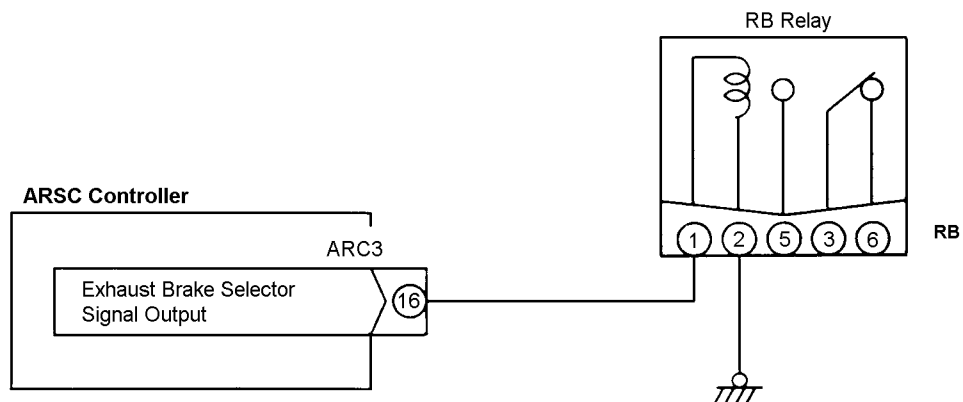

M300008

R-19: Fault Code 7.2 Travel speed display system CLEAR output, open circuit

1. Troubleshooting is performed while the fault is being generated. When the connector is disconnected and the T-adapter is inserted, or when the T-adapter is removed and the connector reinstalled, if the error code is no longer displayed, then the system has been reset.
2. Before troubleshooting, be certain all connectors are properly inserted.
3. Always connect any disconnected connectors before proceeding to the next step.
4. The controller monitors for an open circuit in the CLEAR output to the travel speed display.



R-19 Related Electrical Circuit Diagram

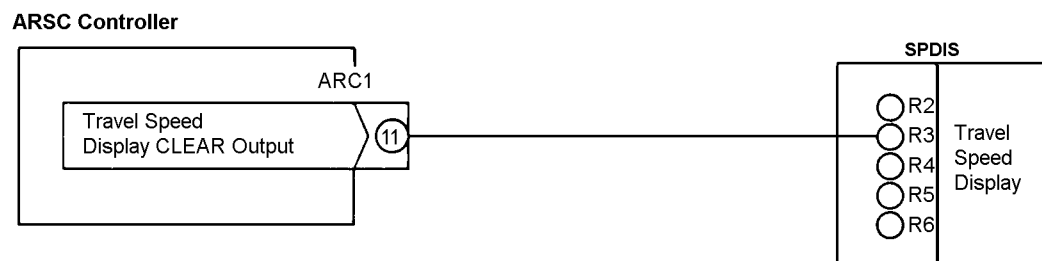

M300019

R-30: Fault Code 9.2 Shut-off valve system failure (valve fails to open)

1. Troubleshooting is performed while the fault is being generated. When the connector is disconnected and the T-adaptor is inserted, or when the T-adaptor is removed and the connector reinstalled, if the error code is no longer displayed, then the system has been reset.
2. Before troubleshooting, be certain all connectors are properly inserted.
3. Always connect any disconnected connectors before proceeding to the next step.
4. The controller monitors for shut-off valve failure by comparing the shut-off valve output command value to the shut-off valve pressure switch input value.

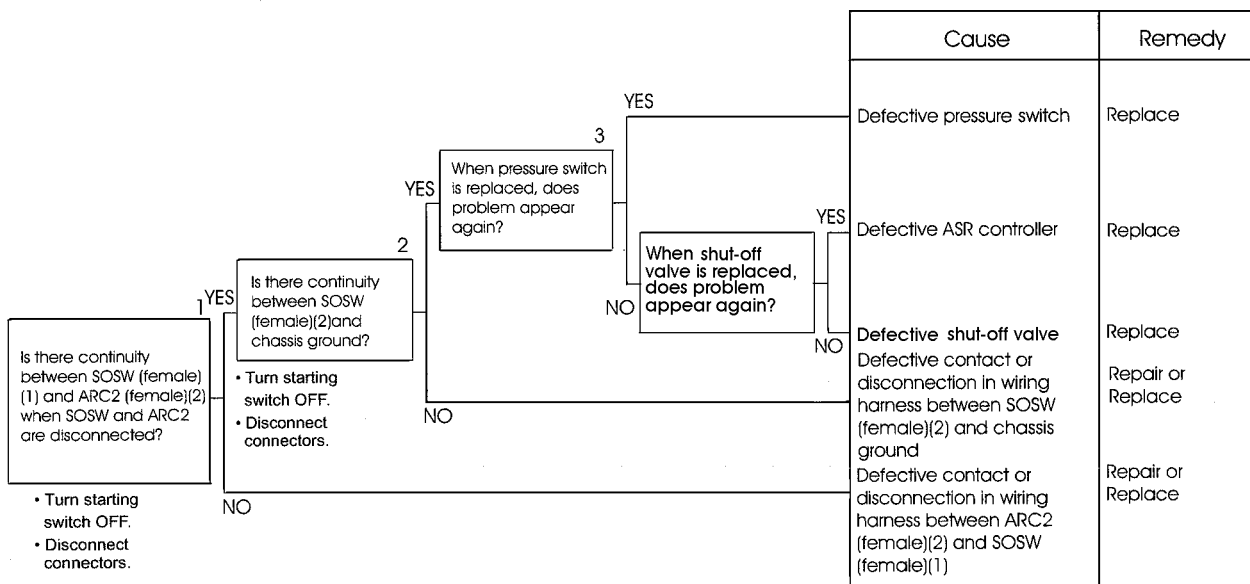

AS-26 (R-30) Related electrical circuit diagram

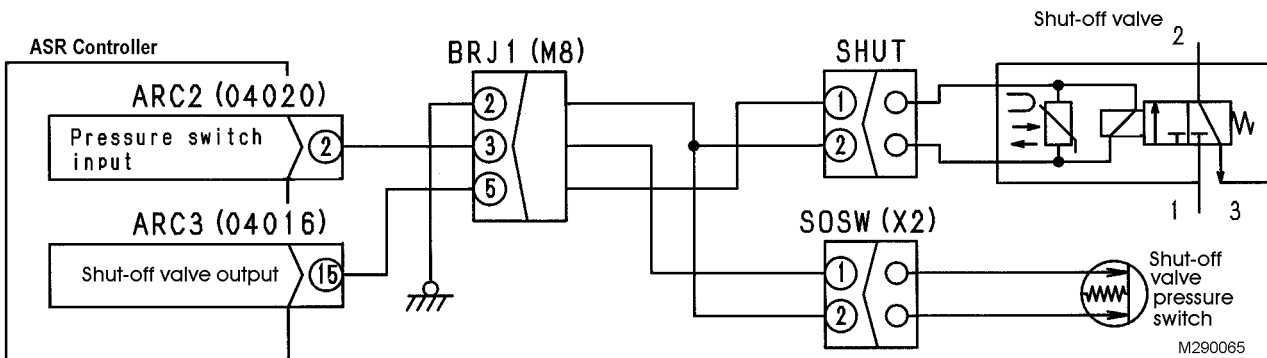

R-107: STANDBY (READY) lamp does not light (or remains lit)

1. Before troubleshooting, be certain all connectors are properly inserted.
2. Always connect any disconnected connectors before proceeding to the next step.

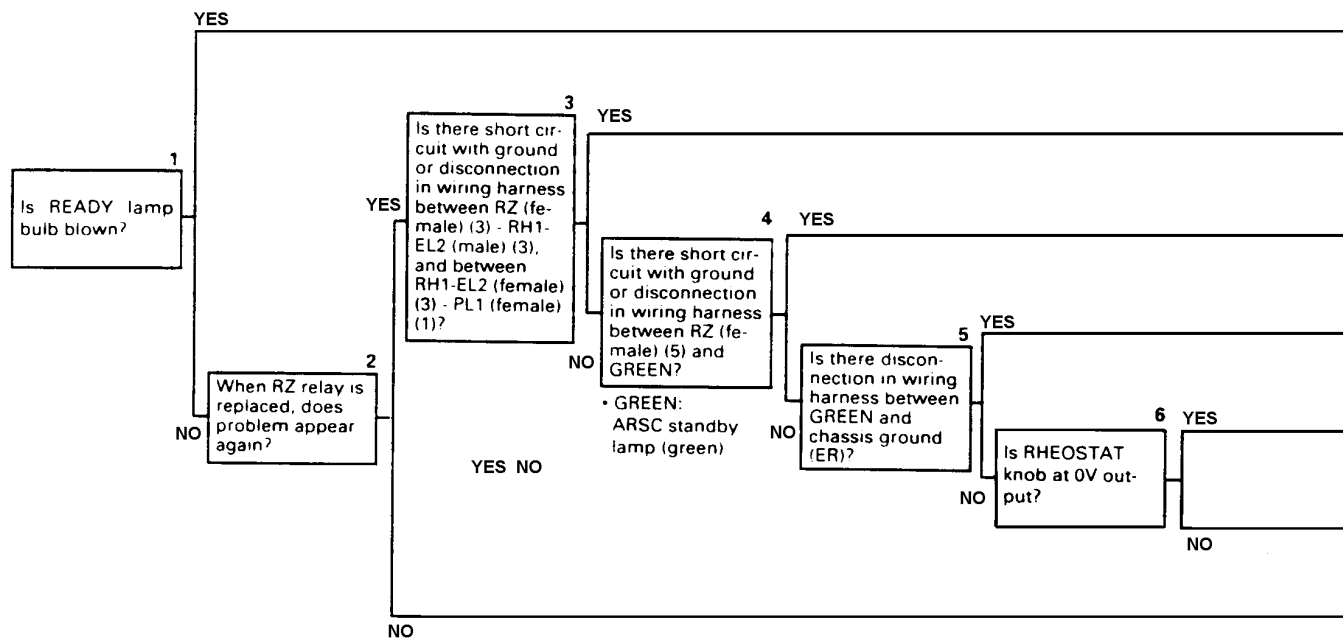

M300039

NOTES

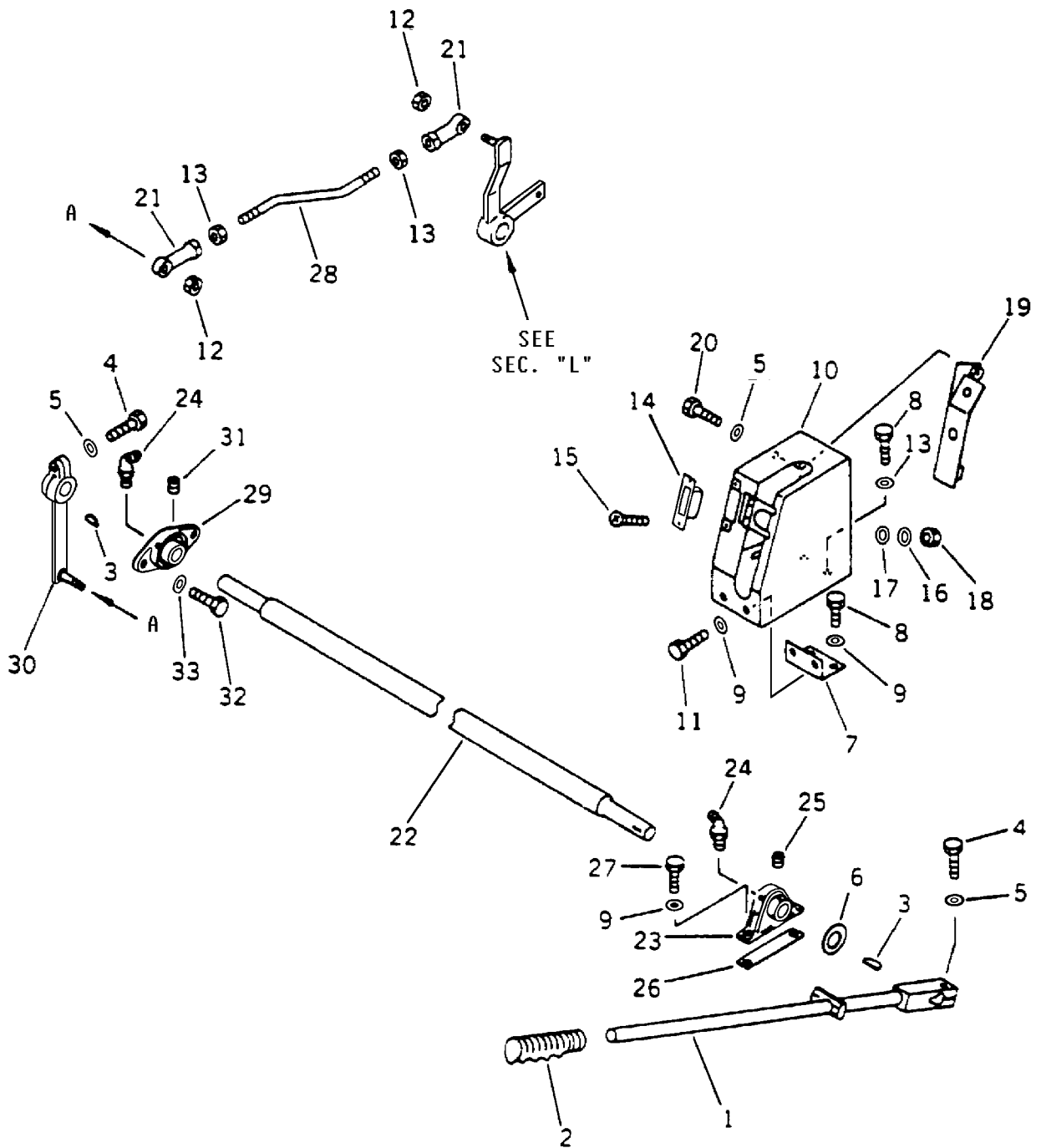

FIGURE 3-3. DUMP CONTROL LINKAGE

- | | | | | |
|------------|-------------|-------------|--------------------|-------------|
| 1. Lever | 8. Bolt | 15. Screw | 22. Shaft | 29. Bearing |
| 2. Grip | 9. Washer | 16. Washer | 23. Bearing | 30. Lever |
| 3. Key | 10. Cover | 17. Washer | 24. Grease Fitting | 31. Screw |
| 4. Bolt | 11. Bolt | 18. Nut | 25. Screw | 32. Bolt |
| 5. Washer | 12. Nut | 19. Bracket | 26. Plate | 33. Washer |
| 6. Washer | 13. Nut | 20. Bolt | 27. Bolt | |
| 7. Bracket | 14. Catcher | 21. Rod End | 28. Rod | |

HEATER AND AIR CONDITIONER UNIT

Removal

1. Drain engine cooling system slightly to avoid coolant loss when removing heater assembly from cab.
2. Refer to Air Conditioning System in this Section for instructions and discharge air conditioner system refrigerant.

Note: Refer to Figure 4-4 for the following procedures.

3. Remove the heater/air conditioner cover in front of the passenger seat by removing the four corner capscrews.
4. Remove the four capscrews and the steel blower cover from the right side of the heater assembly
5. Disconnect the two air conditioner water drain hoses from below air conditioner assembly.
6. Remove four capscrews retaining the left access door (where the recirculation filter is located) in place.
7. Disconnect the two refrigerant lines at the core.
8. Remove control cable from coolant control valve.
9. Remove two capscrews holding the mounting brackets to the cab floor.
10. Disconnect the two heater coolant hoses.
11. Slide heater/air conditioner unit out. While sliding, disconnect wiring harness from blower motor, blower motor resistor and air conditioner sensor.

Installation

1. Slide heater/air conditioner unit in at the same time with the access door on the left side. While sliding unit in, connect wiring harness to blower motor, blower motor resistor and air conditioner sensor.
2. Connect the two heater coolant hoses.
3. Install two capscrews holding the mounting brackets to the cab floor.
4. Install control cable to coolant control valve. Adjust to ensure it travels to complete on and off positions.
5. Connect the two air conditioner lines to the

6. Install four capscrews to hold the left access door (where the recirculation filter is located) in place.
7. Connect the two air conditioner water drain hoses to the air conditioner assembly.
8. Install the four capscrews and the steel blower cover to the right side of the heater assembly
9. Install the heater/air conditioner cover in front of the passenger seat by installing the four corner capscrews.
10. Fill the engine cooling system with the coolant that was drained in Step 1 during removal.
11. Charge the air conditioner system. Refer to Air Conditioning System, this Section for procedures.

HEATER AND AIR CONDITIONER CORE REPLACEMENT

Disassembly

1. Split the assembly by removing ten screws (eight at the split and two on top).
2. Remove motor by removing three screws.
3. Remove resistor by removing two screws.
4. Remove heater core by disconnecting the water pipes and lifting it out of the housing.
5. Remove air conditioning core by removing tube support screw and lifting the core out of the housing.

Refer to Figure 4-4 for further disassembly of unit if necessary, or for replacement of other components. Refer to the appropriate Parts Book for component part numbers.

Assembly

1. Install air conditioning core and tube support screw in the housing.
2. Install heater core and connect the water pipes.
3. Install resistor with two screws.
4. Install motor with three screws.
5. Join the two halves with ten screws (eight at the split and two on top).

SYSTEM SERVICING

Servicing an air conditioning system really means closely monitoring refrigerant flow. For this reason, the following procedures deal extensively with the proper use, handling, care and safety factors involved in the R-134a refrigerant quality and quantity in an air conditioning system.

Because the refrigerant in an air conditioning system must remain pressurized and sealed within the unit to function properly, safety is a major consideration when anything causes this pressurized, sealed condition to change. The following warnings are provided here to alert service personnel to their importance BEFORE learning the correct procedures. Read, remember, and observe each warning before beginning actual system servicing.

NOTE: If the mine operates a fleet with some trucks using R-12 and others using R-134a refrigerant, it is essential that servicing tools that come into contact with the refrigerant (gauge sets, charging equipment, recycle/recovery equipment etc.) be dedicated to one type refrigerant only, to prevent cross contamination.



Federal regulations prohibit venting R-12 and R134a refrigerant into the atmosphere. An SAE and UL approved recovery/recycle station must be used to remove refrigerant from the AC system. Refrigerant is stored in a container on the unit for recycling, reclaiming, or transporting. In addition, technicians servicing AC systems must be certified they have been properly trained to service the system.

Although accidental release of refrigerant is a remote possibility when proper procedures are followed, the following warnings must be observed when servicing AC systems:

Provide appropriate protection for your eyes (goggles or face shield) when working around refrigerant.

A drop of the liquid refrigerant on your skin will produce frostbite. Wear gloves and exercise extreme care when handling refrigerant.

If even the slightest trace of refrigerant enters in your eye, flood the eye immediately with cool water and seek medical attention as soon as possible.

Ensure sufficient ventilation whenever refrigerant is being discharged from a system, keeping in mind refrigerant is heavier than air and will seek low areas of shop.

When exposed to flames or sparks, the components of refrigerant change and become deadly phosgene gas. This poison gas will damage the respiratory system if inhaled. NEVER smoke in area where refrigerant is used or stored.

Never direct steam cleaning hose or torch in direct contact with components in the air conditioning system. Localized heat can raise the pressure to a dangerous level.

Do not heat or store refrigerant containers above 120° F (49° C).

Do not flush or pressure test the system using shop air or another compressed air source. Certain mixtures of air and R-134a refrigerant are combustible when slightly pressurized. Shop air supplies also contain moisture and other contaminants that could damage system components.

Receiver-Drier

The receiver-drier can not be serviced or repaired. ***It must be replaced whenever the system is opened for any service.*** The receiver-drier has a pressure switch to control the clutch, and should be removed and installed onto the new unit.

Thermostat

A thermostat can be stuck open or closed due to contact point wear or fusion. The thermostat temperature sensing element (capillary tube) may be broken or kinked closed and therefore unable to sense evaporator temperature.

When thermostat contact points are stuck open or the sensing element can not sense temperature in the evaporator, the clutch will not engage (no AC system operation). Causes are a loss of charge in the capillary tube or a kink, burned thermostat contact or just no contact. When troubleshooting, bypass the thermostat by hot wiring the clutch coil with a fused lead. If the clutch engages, replace the thermostat.

Thermostat contact points may be fused (burned) closed and the clutch will not disengage. Causes are a faulty switch that could be due to fatigue. The thermostat must be replaced. When the clutch will not disengage you may also note that condensate has frozen on the evaporator fins and blocked air flow. There will also be below normal pressure on the low side of the system. Side effects can be compressor damage caused by oil accumulation (refrigeration oil tends to accumulate at the coldest spot inside the system) and lower than normal suction pressure that can starve the compressor of oil.

Compressor

The compressor can fail due to shaft seal leaks (no refrigerant in the system), defective valve plates, bearings, or other internal parts or problems associated with high or low pressure, heat, or lack of lubrication. Be sure the compressor is securely mounted and the clutch pulley is properly aligned with the drive pulley.

Use a mechanic's stethoscope to listen for noises inside the compressor.

Clutch

Clutch problems include electrical failure in the clutch coil or lead wire, clutch pulley bearing failure, worn or warped clutch plate or loss of clutch plate spring temper. Defective clutch assembly parts may be replaced or the whole assembly replaced. If the clutch shows obvious signs of excessive heat damage, replace the whole assembly.

The fast way to check electrical failure in the lead wire or clutch coil is to hot wire the coil with a fused lead. This procedure enables you to bypass clutch circuit control devices.

Clutch pulley bearing failure is indicated by bearing noise when the AC system is off or the clutch is not engaged. Premature bearing failure may be caused by poor alignment of the clutch and clutch drive pulley.

Sometimes it may be necessary to use shims or enlarge the slots in the compressor mounting bracket to achieve proper alignment.

Excessive clutch plate wear is caused by the plate rubbing on the clutch pulley when the clutch is not engaged or the clutch plate slipping when the clutch coil is energized. A gap that is too small or too large between the plate and clutch pulley or a loss of clutch plate spring temper are possible causes. The ideal air gap between the clutch pulley and the clutch plate is 0.023 to 0.057 in. (1.02 ± 0.043 mm). If the gap is too wide, the magnetic field created when the clutch coil is energized will not be strong enough to pull and lock the clutch plate to the clutch pulley.

IMPORTANT

NOTE: Some compressors may be discarded because it is suspected that internal components within the compressor have seized. Ensure that the compressor clutch is working properly before discarding a compressor for internal seizure. The normal compressor life span should be about twice as long as the normal life span of the compressor clutch.

It is important to note that often times a weak clutch coil may be mistaken for a seized compressor. When a coil's resistance has increased over time and the magnetic field weakens, the coil may not be able to pull the load of the compressor. Failure of the coil to allow the compressor shaft to be turned, may appear as though the compressor is locked up.

PROBLEM: Extremely Low Refrigerant Charge in the System

Indications:

Low side pressure - LOW.
High side pressure - LOW.
Discharge air is warm.
The low pressure switch may have shut off the compressor clutch.

Possible Causes

- Extremely low or no refrigerant in the system.
Possible leak in the system.

Suggested Corrective Actions

Check for leaks by performing leak test.

No Leaks Found:

Recover refrigerant from the system. Recharge using a scale to ensure correct charge. Check AC operation and performance.

Leaks Found:

Add refrigerant (make sure system has at least 50% of its normal amount) and leak test system. It may be necessary to use a jumper wire to enable the compressor to operate, if the compressor has shut down due to faulty pressure sensing switch. Repair any leaks and evacuate the system if necessary. Replace the receiver-drier if the system was opened. Recharge the system using a scale and add oil as necessary. Check AC operation and do system performance test.

PROBLEM: Air and/or Moisture in the System

Indications:

Low side pressure - Normal
High side pressure - Normal
Discharge air is only slightly cool.
(In a cycling type system with a thermostatic switch, the switch may not cycle the clutch on and off, so the low pressure gauge will not fluctuate.)

Possible Causes

Leaks in the system.

Suggested Corrective Actions

Test for leaks, especially around the compressor shaft seal area. When the leak is found, recover refrigerant from the system and repair the leak. Replace the receiver-drier or accumulator because the desiccant may be saturated with moisture. Check the compressor and replace any refrigerant oil lost due to leakage. Evacuate and recharge the system with refrigerant using a scale. Check AC operation and performance.

Headlights and Dimmer Switch

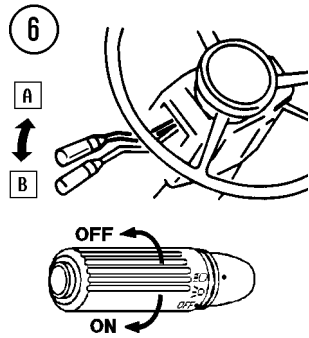

The headlights and dimmer switch (6, Figure 5-1) is part of the turn signal lever function. The headlights are turned Off and On by rotating the switch on the end of the lever handle. The switch has three positions: OFF; RUNNING/CLEARANCE LIGHTS; and HEADLIGHTS.

The dimmer switch is part of the turn signal lever function.

Pulling the lever up will activate headlights to low beam [A]. Pushing the lever down activates headlights to high beam [B].

Retard Control Lever

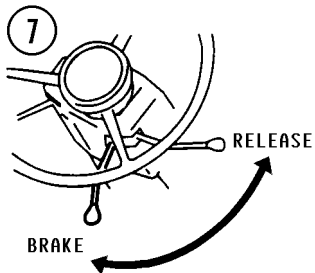

The retarder control lever (7) allows the operator to apply only the **REAR** oil-cooled brakes. During normal operation, this lever should be used to control the speed of the truck and to stop the truck instead of

using the foot-operated service brake pedal. Use of this lever extends front brake life while maintaining maximum control of the truck.

BRAKE PEDAL

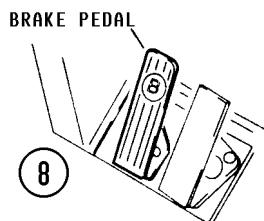

The brake pedal (8) is a foot-operated pedal which activates air-over-hydraulic pressure converters which apply front caliper dry disc brakes and rear oil-cooled wet disc brakes. This pedal should be used when

maneuvering in tight places, at the shovel and dump, and when quick stops or severe braking is required.

THROTTLE PEDAL

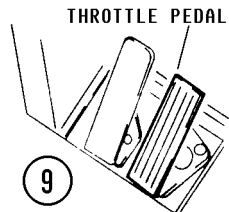

The throttle pedal (9) is a foot operated treadle pedal which allows the operator to control fuel to the engine to provide engine acceleration.

The electronic treadle pedal sends signals to the electronic engine fuel control system. The movement of the governor control arm corresponds directly to travel of the treadle pedal as applied by the operator. When the pedal is released, a spring returns the pedal and governor control arm to the low idle position.

CENTER CONSOLE AND CONTROLS

The center console (10, Figure 5-1) is located to the right of the Operator.

Transmission Range Selector

The transmission range selector (1, Figure 5-2) has seven positions (R, N, D, 5, 4, 3, and L).



When operating the shift lever, be sure to set it in position securely (detent). If the lever is not in a detent position, the shift position display on the panel may go out and the transmission warning monitor lamp may light up.

When shifting between FORWARD and REVERSE, stop the machine completely, and reduce engine speed to low idle when moving the lever.

If the parking brake is not released, and the shift lever is moved to a position other than N, the central warning lamp will flash and the alarm buzzer will sound.

If the dump lever is not at the FLOAT position, and the shift lever is moved to a position other than N, the central warning lamp will light up and the alarm buzzer will sound.

Do not move the shift lever with the accelerator pedal depressed. This will cause shift shock, and will reduce the life of drive train components.

To Cancel Set Travel

- If the cancel switch is operated for more than 1 second, the control is stopped. When this happens, the travel speed display shows "0".

OR

- If the system switch is turned Off, the control is canceled. When the system switch is OFF, the travel speed display turns off.

NOTE: The cancel switch must be operated for at least 1 second (different from other switches) to cancel the control. This is to prevent cancelling operation if the switch is touched accidentally.

Relationship With Exhaust Brake

If the exhaust brake switch (12, Figure 5-3) is in the ON position, the exhaust brake is actuated normally when the accelerator pedal is released if the torque converter lock-up is On. If the truck attempts to exceed the set speed, the ARSC is actuated.

If the exhaust brake switch is in the OFF position, the exhaust brake is not actuated when the ARSC is being operated. If the foot brake or retarder control lever are operated, the exhaust brake is actuated normally.

If the downhill slope is not steep and the engine brake and exhaust brake have ample effect, the truck will not accelerate to the set travel speed and the ARSC may not be actuated.

Recommended Set Speed

Set the travel speed so that the engine speed is at least 1800 rpm, and operate the truck keeping the retarder oil temperature gauge in the green range.

If there is danger that the retarder oil may overheat, the ASR/ARSC caution lamp (6, Figure 5-3) will illuminate and the set travel speed is automatically reduced.



ARSC system travel speeds must be set according to operating conditions. Refer to Retarding Capacity decal in cab for proper gear range and maximum truck speeds when descending grades.

Do not exceed maximum engine speed or brake oil temperature.

The ARSC system is actuated only if the system switch is On. If the operator desires to have the system automatically control truck speed on a downhill grade, verify the system switch is ON.

On slippery road surfaces, the wheels may lock when the ARSC system is actuated. IF ROAD CONDITIONS ARE POOR, DO NOT USE THE ARSC SYSTEM.

If a problem occurs in the system and it becomes impossible to maintain accurate control of the truck, a warning is given, the system will turn Off if a serious problem has occurred and the ARSC system is released. The operator should then use the foot brake and retarder control lever to maintain control and move the truck to a safe place, then turn the system switch OFF.

AISS/Auto Switch

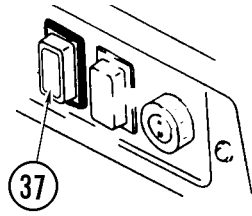

The AISS (automatic idle selector switch, 37, Figure 5-7) may be positioned to LOW or AUTO as desired. This switch is used by the operator to control the idle speed of the engine.

LOW position (switch IN - light ON) is the MANUAL POSITION and is used when fine control movements are needed, such as when parking, or driving in/out of confined spaces.

AUTO position (switch OUT - light OFF) is used for normal operations. The following conditions occur:

1. When the machine is stopped, the idling speed is automatically set to LOW speed when the parking brake or retarder is ON. When the parking brake is released to start traveling, the idling speed is automatically set to HIGH speed.
2. If the coolant temperature is low, the idling speed is automatically set to HIGH speed to reduce the time taken for the warming up operation.

Manual Starting Aid Switch

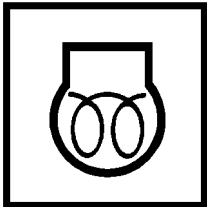

This truck is equipped with an **automatic** cold start aid.

The cold starting aid energizes the electric heaters in the engine intake manifold.

Under normal conditions, there is no need to use this **MANUAL** switch. If the outside temperature is below -5°C (23°F) and the prelube starter runs a long time, this manual switch can be pushed IN for 2-3 seconds before starting the engine to maintain engine pre-heating.

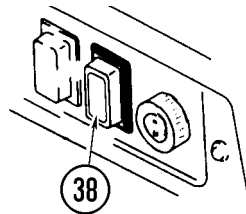

The Starting Aid Switch (38) is spring-loaded to the OUT/OFF position.



DO NOT PUSH COLD STARTING AID BUTTON AFTER ENGINE HAS STARTED! SERIOUS DAMAGE TO ENGINE MAY OCCUR!

Starting Switch

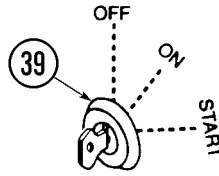

The starting switch (39, Figure 5-7) is a three-position key-switch:

OFF Position - Key insertion/withdrawal position - None of the electrical circuits activate in this position. Turn the switch to

OFF to stop the engine.

ON - Lamp circuits activate in this position.

START - At this key position, the starting motor will crank the engine. Release the key immediately after engine starts; the key will return automatically to ON.

Pilot Lamp Bulb Check Switch

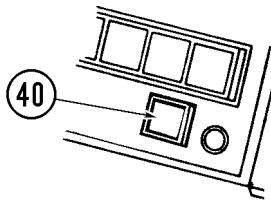

Turn the starting switch (39) to ON and press the pilot lamp bulb check switch (40) to check if bulbs will light. All pilot lamp bulbs should light.

Rear Brake Pilot Lamp

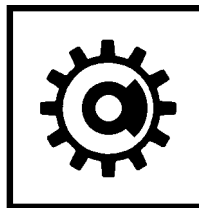

The rear brake pilot lamp (41) lights up when the service brake is depressed or the retarder control lever is pulled to actuate the rear brake.

Body Float Caution Monitor

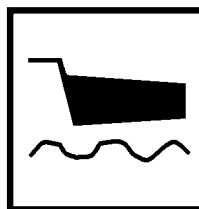

When the dump body control lever is set to any position other than FLOAT, or the body is not seated on the frame, the body float caution monitor (42) lights up.

When traveling, always set the lever to FLOAT position with the body seated.

CLICK HERE TO **DOWNLOAD** THE COMPLETE MANUAL

- Thank you very much for reading the preview of the manual.
- You can download the complete manual from: www.heydownloads.com by clicking the link below



- Please note: If there is no response to CLICKING the link, please download this PDF first and then click on it.

CLICK HERE TO **DOWNLOAD** THE COMPLETE MANUAL