

# Shop Manual

MOTOR GRADER

***GD675-7E0***

SERIAL NUMBERS 65001 and up

**KOMATSU**

CLICK HERE TO **DOWNLOAD** THE COMPLETE MANUAL

- Thank you very much for reading the preview of the manual.
- You can download the complete manual from: [www.heydownloads.com](http://www.heydownloads.com) by clicking the link below



- Please note: If there is no response to CLICKING the link, please download this PDF first and then click on it.

CLICK HERE TO **DOWNLOAD** THE COMPLETE MANUAL

## Preventing Intrusion of Foreign Materials While You Refill

- During refilling with the hydraulic oil, do not let water enter the electrical components.
- Clean the oil filler port and its around, refilling pump, oil jug, or etc.
- Refilling by using an oil cleaning device is better method since it can filtrate the contaminants accumulated in the oil during storage.

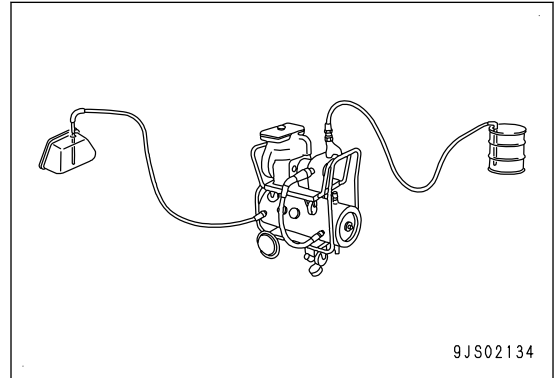

## Replace Hydraulic Oil While Its Temperature is High

- The higher the oil temperature is, the softer the oil is, and the smoother the oil runs. Also, the sludges are easily discharged from the circuit. Perform the replacement while oil temperature is high.
- Old hydraulic oil needs to be drained as much as possible when replacing.

### NOTICE

Old hydraulic oil contaminates the new one if it is mixed since it contains contaminants and sludges, and the service life of the hydraulic oil is shortened.

### REMARK

Drain the old hydraulic oil not only from the hydraulic tank but also from the filter and drain plug in the circuit.

## Do Not Use the Hydraulic Oil and Lubricating Oil Again

Avoid reusing the hydraulic oil and lubricating oil which has been drained from the machine.

If reused, any foreign material may enter the hydraulic equipment, and it may cause a failure.

## Flushing Operation

- Flushing is required to completely dislodge the contaminants and sludges, and existing oil containing those inside the hydraulic circuit after disassembling and assembling, and when replacing the oil with the new one.
- Normally, flushing is performed twice. Primary flushing is performed by using the flushing oil (1) and the secondary flushing is performed by using the specified hydraulic oil.

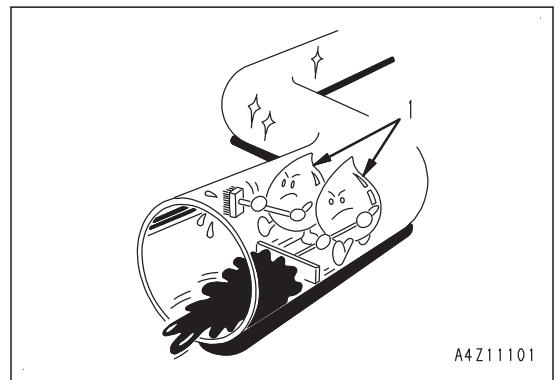

## Cleaning Operation

Perform oil cleaning to remove the contaminants and sludges in the hydraulic circuit after repair of the hydraulic device (pump, or control valve) or during operation of the machine.

## Abbreviation List

- This list of abbreviations includes the abbreviations for functions, devices, and parts which are used in the shop manual.
- Commonly used abbreviations are not included.
- Special abbreviations which are not shown frequently are included in the text as additional information.

### List of Abbreviations Used in the Text

Abbreviation	Actual word spelled out	Explanation
API	American Petroleum Institute	API is the abbreviation for American Petroleum Institute.
CAN	Controller Area Network	CAN is one of networks that communicate between the machine monitor and controllers.
CDR valve	Crankcase Depression Regulator valve	CDR valve is a valve that is attached to the KCCV ventilator.
CLSS	Closed-center Load Sensing System	CLSS is a hydraulic system that provides total control over the pumps, valves, and actuators. When actuators are in neutral, pump circuits are closed.
CRI	Common Rail Injection	CRI is a function that is composed of the supply pump, common rail, and injector, and that controls the fuel injection rate and injection timing.
DEF	Diesel Exhaust Fluid	DEF is a urea solution that is used for the SCR system.
ECM	Electronic Control Module	ECM is an electronic device that controls actuators adequately with signals from sensors.
ECMV	Electronic Control Modulation Valve	ECMV is a device that controls the connection and disconnection of clutches of the transmission and brake.
ECSS	Electronically Controlled Suspension System	ECSS is a function that decreases bucket vibration during travel to reduce load spillage and operator's fatigue.
ECU	Electronic Control Unit	ECU is an electronic device that controls actuators adequately with signals from sensors.
EGR	Exhaust Gas Recirculation	EGR is a function that recirculates part of exhaust gas to the intake side to control NOx emissions.
EPC	Electromagnetic Proportional Control	EPC is a function that controls the pressure of the hydraulic circuit in proportion to the electric current.
EPC	Electrical Pressure Control	EPC is a function that controls the pressure of the hydraulic circuit in proportion to the electric current.
FOPS	Falling Object Protective Structure	FOPS is a structure that protects operators from falling objects.
GNSS	Global Navigation Satellite System	GNSS is a general term for satellite positioning systems.
GPS	Global Positioning System	GPS is one of satellite positioning systems.
IMA	Inlet Metering Actuator	IMA is a device that controls fuel intake volume at the inlet of the supply pump.
IMV	Inlet Metering Valve	IMV is a device that controls fuel intake volume at the inlet of the supply pump.
KCCV	KOMATSU Closed Crankcase Ventilation	KCCV is a function that isolates oil from blowby gas in the engine and returns the blowby gas to the intake side.
KCSF	KOMATSU Catalyzed Soot Filter	KCSF is a filter that catches soot in exhaust gas.

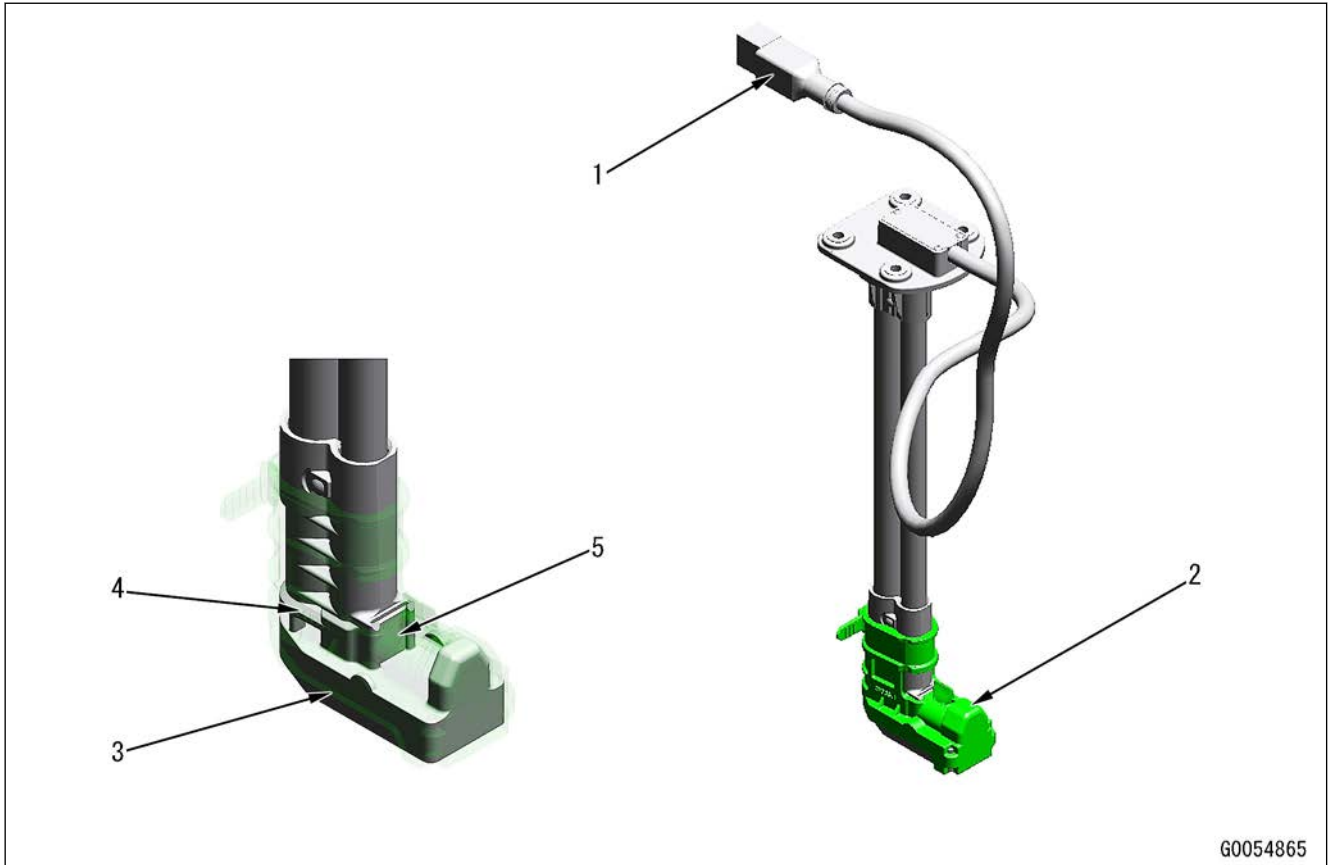

1: Connector

2: Cover (If equipped)

3: Temperature sensing part

4: Level sensing part

5: Concentration sensing part

### Function of DEF Tank Sensor

- This sensor is installed to DEF tank and outputs DEF level, DEF concentration, and DEF temperature through CAN communication.
- DEF level and DEF concentration are measured by using ultrasonic wave.
- When the tank is frozen or empty, DEF level and DEF concentration are not measured.

### Function of Cooling Fan Motor

The cooling fan motor changes fluid movement from the pump into fan rotation movement.

### Operation of Cooling Fan Motor

The shaft (1) is supported in the case (2) by the bearing (9). The piston (5) is contained in each cylinder of the cylinder block (6), and it can slide in the axial direction. The spherical side of the shoe (4) is connected to the point of the piston (5), so the shoe can swing. Also, the shoe (4) is connected, and it can slide on the flat surface (A) of the thrust plate (3). The cylinder block (6) is connected to the shaft (1) through the spline (a). The cylinder block (7), piston (6), and shoe (5) rotate together with the shaft (1).

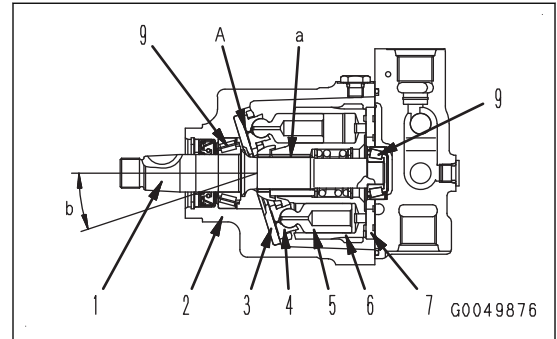

The angle between the vertical axis of the flat surface (A) of the thrust plate (3) and the axis of the shaft (1) is called the swash plate angle (b). The swash plate angle (b) is fixed at a given angle.

The hydraulic force from the pump pushes the piston (5) from the cylinder block (6). The thrust of the piston (5) is applied to the thrust plate (3) through the shoe (4), and the force to push the thrust plate (3) (F2) and force to slide on the thrust plate (F3) act on the plate by the force (F3) that the piston (5) slides on the thrust plate (3). The piston (5) of the cylinder block (6) and the opposite end are connected to rotate relatively to the valve plate (7) fixed to the case (2).

The valve plate (7) has holes, one of which is at a position where the hydraulic oil from the cylinder block (6) flows in, and the other is at the position where the hydraulic oil is discharged to. The holes are connected to the pump and hydraulic oil tanks.

The cylinder block (6) rotates. When the cylinder block (6) rotates and the thrust plate (3) pushes the piston (5), hydraulic oil is discharged.

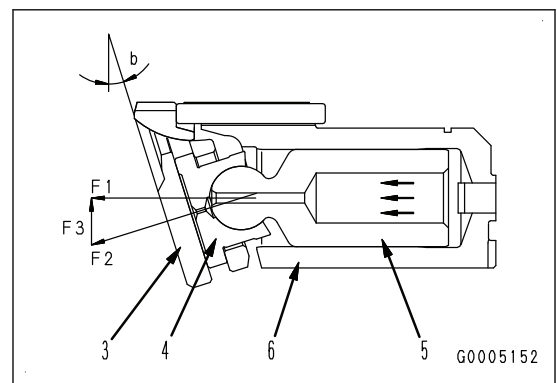
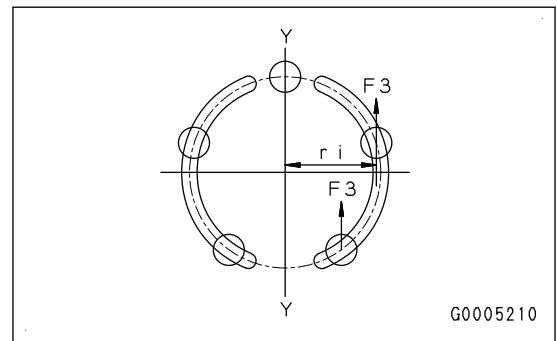

## KOMTRAX Terminal

### Function of KOMTRAX Terminal

Model: TC630/TC635/TC330

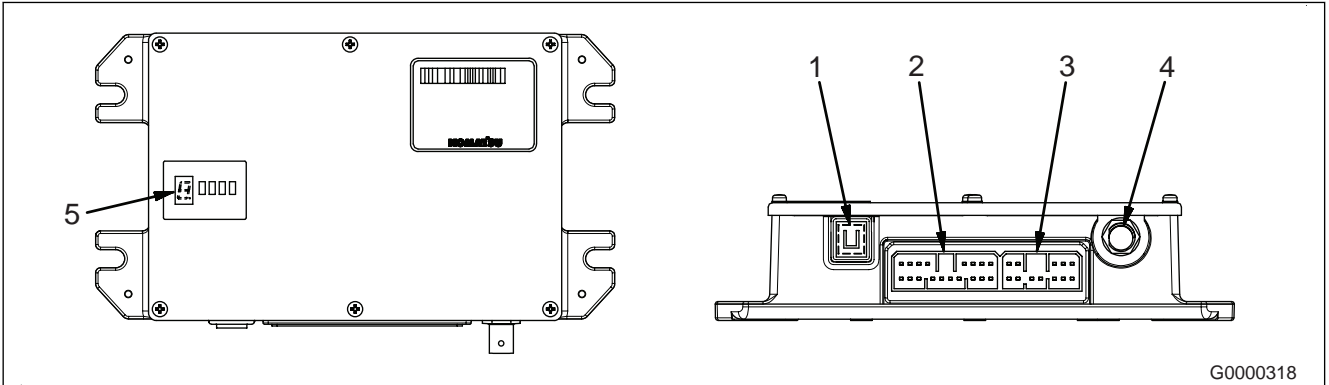

1: GPS antenna connection part

4: Communication antenna connection

2: Machine harness connection (070-18P)

5: LED lamp display

3: Machine harness connection (070-12P)

The KOMTRAX terminal is a device that transmits various pieces of machine information obtained from the network signals and input signals and also the GPS position information via wireless communication. Information is transmitted by the communication antenna.

The condition of the KOMTRAX terminal can be checked on the KOMTRAX Settings on the service mode of the machine monitor.

KOMTRAX terminal cannot be used in countries or regions where there is no permission by law.

The KOMTRAX terminal has LED lamps and 7-segment LED used for inspection and troubleshooting on its display section.

#### REMARK

Each country or region has different communication method (communication company). The KOMTRAX terminal has built-in communication devices that are applicable to each country or region.

To use KOMTRAX terminal in a different country, authorization in the country where the machine is used is possibly required. For details, consult the person responsible for KOMTRAX at your local Komatsu distributor.

### Input and Output Signals of KOMTRAX Terminal

#### 070-18P “L80A”

Pin No.	Signal name	Input and output signals
1	(*1)	-
2	(*1)	-
3	(*1)	-
4	(*1)	-
5	(*1)	-
6	(*1)	-
7	(*1)	-
8	(*1)	-
9	(*1)	-
10	CAN (C)_H	Input and output
11	CAN (C)_L	Input and output

Sectional View (G-G, H-H, J-J, K-K)

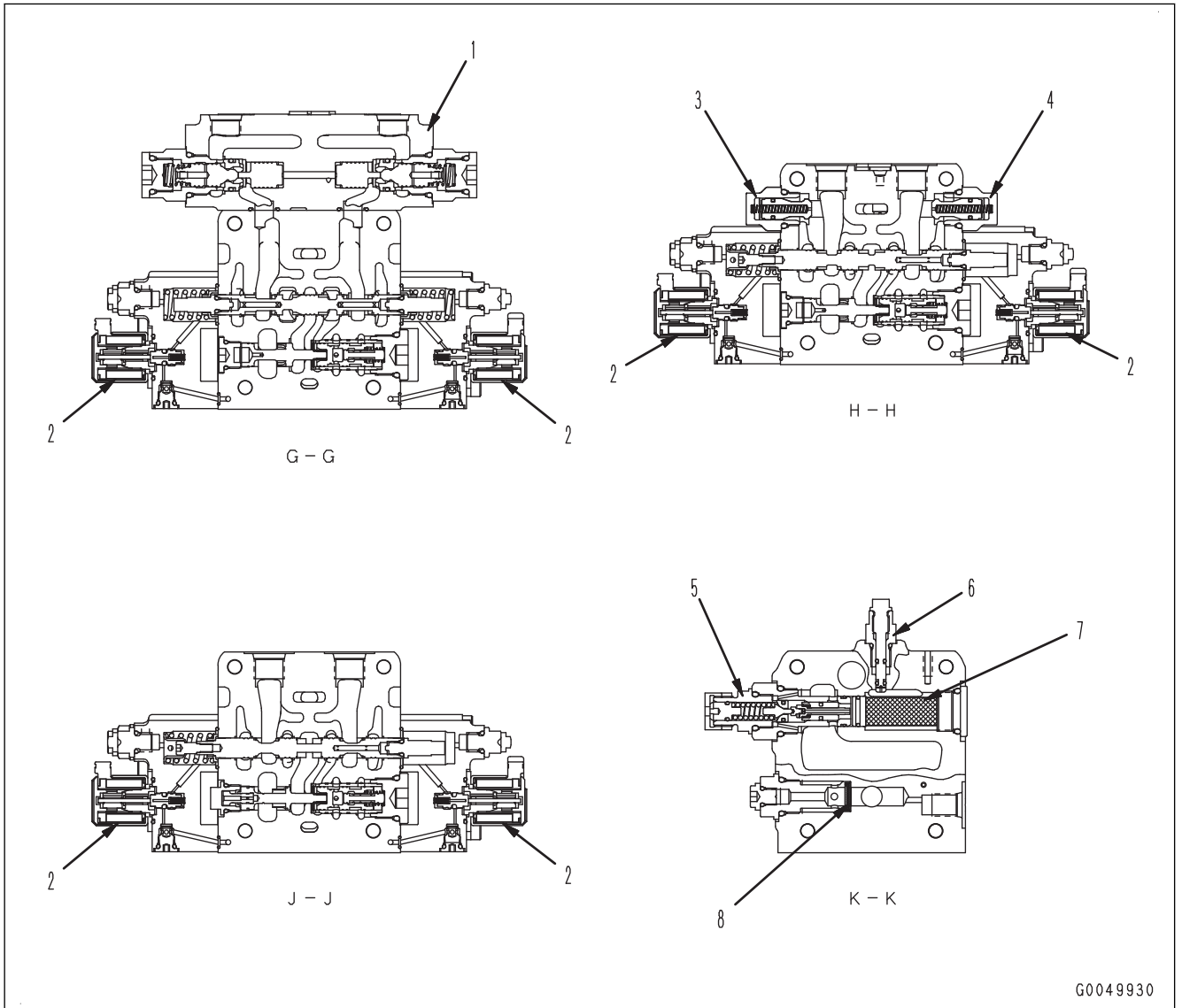

- 1: Pilot check valve (blade power tilt cylinder)
- 2: EPC valve
- 3: Suction valve (blade side-shift cylinder bottom)
- 4: Suction valve (blade side-shift cylinder head)

- 5: Centralized safety valve
- 6: Cylinder pressure release plug (centralized circuit)
- 7: Centralized safety valve filter
- 8: Pump circuit filter

↓

FL clutch gear (5)

↓

FH, 1st cylinder gear (12)

↓

Upper shaft (13)

↓

Upper gear (15)

↓

2nd clutch gear (16)

↓

2nd clutch (18)

↓

2nd, 3rd ring gear (20)

↓

Lower shaft (21)

↓

Lower gear (22)

↓

Output gear (25)

↓

Transmission output shaft (27)

### Cross Slope System

Machines with cross slope system

#### System Diagram of Cross Slope System

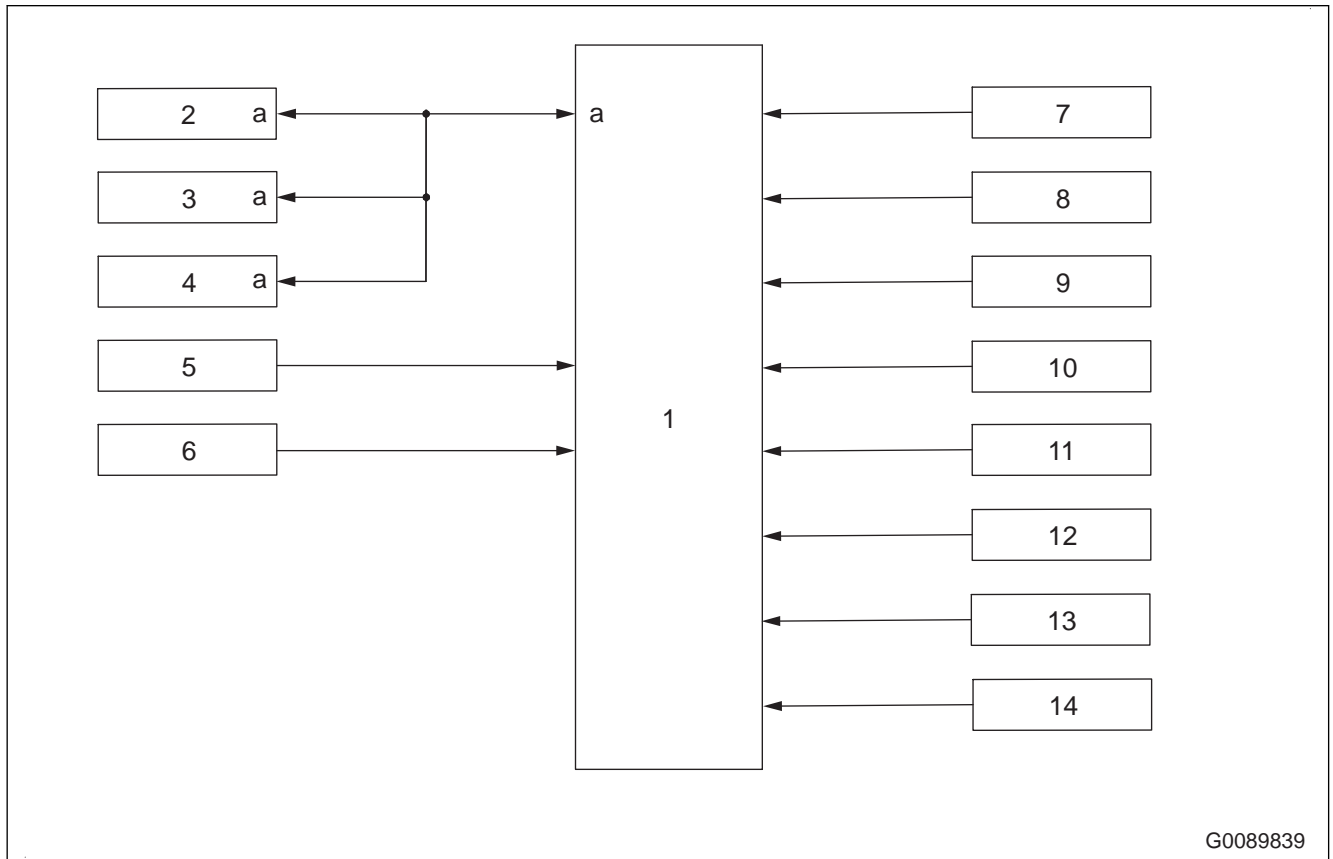

a: CAN signal

1: Work equipment controller

2: Machine IMU

3: Drawbar IMU

4: Blade rotation angle sensor

5: Work equipment electric lever

6: Cross slope activation switch

7: Auto/manual switch (R.H.)

8: Auto/manual switch (L.H.)

9: Target cross slope increase switch

10: Target cross slope decrease switch

11: Preset 1 selection switch

12: Preset 2 selection switch

13: Slope match activation switch

14: Work equipment EPC valve

#### Function of Cross Slope System

The cross slope system automatically control the blade to the desired cross slope set by the operator.

**REMARK**

For the operation method of the cross slope, see the “Operation and Maintenance Manual”.

# Standard Value Table for Engine

## Standard Value Table for Engine: GD675-7E0

### Engine: SAA6D107E-3

#### Performance

Item	Test condition	Unit	Standard value for new machine	Failure criterion	
Engine speed at high idle	<ul style="list-style-type: none"> <li>Engine coolant temperature: 80 to 90 °C</li> <li>Hydraulic oil temperature: 45 to 55 °C</li> <li>Torque converter oil temperature: 60 to 80 °C</li> <li>Accelerator pedal: Push the pedal fully to the stroke end</li> </ul>	Power mode: P mode	r/min {rpm}	2100 to 2200 {2100 to 2200}	2100 to 2200 {2100 to 2200}
		Power mode: E mode	r/min {rpm}	1820 to 1920 {1820 to 1920}	1820 to 1920 {1820 to 1920}
Engine speed at low idle	<ul style="list-style-type: none"> <li>Engine coolant temperature: 80 to 90 °C</li> <li>Hydraulic oil temperature: 45 to 55 °C</li> <li>Torque converter oil temperature: 60 to 80 °C</li> <li>Accelerator pedal: Not pushed</li> </ul>	r/min {rpm}	760 to 860 {760 to 860}	760 to 860 {760 to 860}	

#### Air Intake and Exhaust System

Item	Test condition	Unit	Standard value for new machine	Failure criterion	
Boost pressure	<ul style="list-style-type: none"> <li>Engine coolant temperature: 60 to 100 °C</li> <li>Hydraulic oil temperature: 45 to 55 °C</li> <li>Torque converter oil temperature: 60 to 80 °C</li> <li>T/C Stall mode</li> </ul>	kPa {mmHg}	Min. 120 {Min. 900}	Min. 100 {Min. 750}	
Exhaust temperature	<ul style="list-style-type: none"> <li>Engine coolant temperature: 60 to 100 °C</li> <li>Hydraulic oil temperature: 45 to 55 °C</li> <li>Torque converter oil temperature: 60 to 80 °C</li> <li>T/C Stall mode</li> <li>Full speed range (ambient temperature 20 °C)</li> </ul>	°C	Max. 650	Max. 700	
Exhaust gas color	<ul style="list-style-type: none"> <li>Engine coolant temperature: 60 to 100 °C</li> <li>Accelerator pedal: Push fully to the stroke end (High idle)</li> <li>After it is kept for 5 seconds at normal condition</li> </ul>	Engine outlet (VGT to KDPF)	Bosch index	-	Max. 2.2
		SCR outlet (exhaust pipe outlet)	Bosch index	-	Max. 0.5
Valve clearance	Engine coolant temperature: Normal temperature	Intake valve	mm	0.25	0.152 to 0.381
		Exhaust valve	mm	0.51	0.381 to 0.762

**REMARK**

For the procedure for the torque converter stall, see "Examine Engine Speed".

- 2) After the exhaust gas temperature increases to approximately 670 °C, set the blade lift cylinder control lever to NEUTRAL. Check the exhaust gas temperature when the torque converter alone is stalled.

**REMARK**

- As the exhaust temperature decreases from the full stall, check the temperature in a stable condition.
  - If the exhaust temperature does not decrease but increase, make the set temperature at full stall higher.
- 3) When the check is completed, immediately lift your right foot off the accelerator pedal.
  - 4) Set the directional selector switch to the NEUTRAL (N) position. Set the parking brake switch ON.

**NOTICE**

**Do not operate the directional selector switch while you push the accelerator pedal. Large gear shift shock will occur. It will be a cause to make the service life of the machine short.**

**Restoration**

7. Stop the engine.

**⚠ Immediately after the engine is stopped, the parts and oil become very hot and can cause burn injury. Do the work after the temperature dropped.**

8. Remove the sensor A2.

9. Install the pickup plug (5).

 Pickup plug (5): Seizure prevention compound (LC-G)

 Pickup plug (5): 3.9 to 6.9 Nm {0.4 to 0.7 kgm}

10. Install the heat insulation plate (4) with the bolts (3) (8 pieces).

11. Close the covers (1) and (2) on the left side of the machine. Restore the machine.

## Examine and Adjust Air Conditioner Compressor Belt Tension

Obey the procedures that follow to inspect and adjust the tension of the air conditioner compressor belt.

- ⚠ **Place the machine on a level ground, and lower the work equipment fully to the ground.**
- ⚠ **Set the parking brake switch to the ON position, the work equipment lock switch to the LOCK state, and the steering control lever enable switch to the DISABLE state. Then, stop the engine.**
- ⚠ **Chock the tires to prevent machine movement.**

For standard values, see Standard Value Table, "Standard Value Table for Engine".

### How to Examine Air Conditioner Compressor Belt Tension

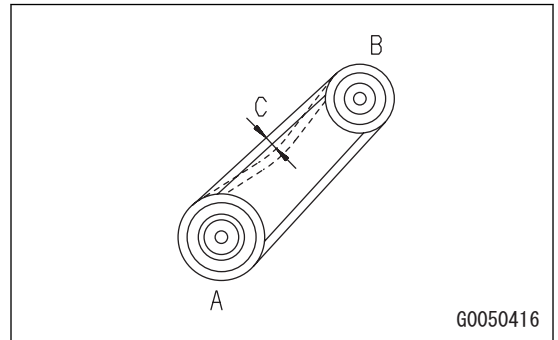

1. Push a point between the drive pulley (A) and the compressor pulley (B) with your finger (approximately 98.1 N {10.0 kg}). Pull the belt to make sag c 19 to 20.5 mm (15.5 to 17 mm for a new belt).  
New belts usually show initial stretch. Thus, adjust the belt every 2 to 3 days.
2. Check each pulley for breakage. Inspect the V-groove for wear. Inspect the V-belt for wear.  
Carefully examine and make sure that the V-belt does not touch the bottom of the V-groove.

### How to Adjust Air Conditioner Compressor Belt Tension

#### NOTICE

- Check each pulley for breakage. Inspect the V-groove for wear. Inspect the V-belt for wear. Carefully examine and make sure that the V-belt does not touch the bottom of the V-groove.
  - Replace the belt with a new one if the belt is stretched and has no allowance for adjustment or has slipping sound or whine because of cuts or cracks in the belt.
  - When you replace the V-belt, adjust it again after operating for 1 hour.
  - When adjusting the V-belt, use a wrench. Do not push the compressor directly with a bar.
1. Open covers (1) and (2) on the right side of the machine.

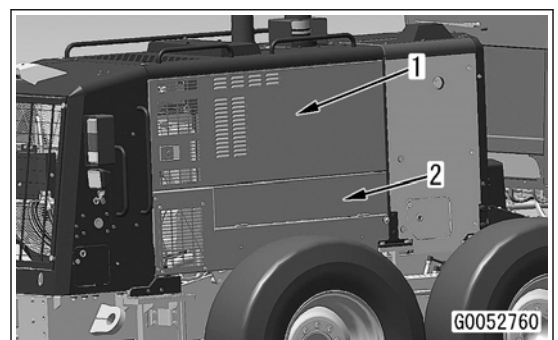

**Refilling DEF**

25. Refill the DEF tank with DEF in accordance with the procedures that follow.
26. Make sure that the drain plug (7) is securely closed.

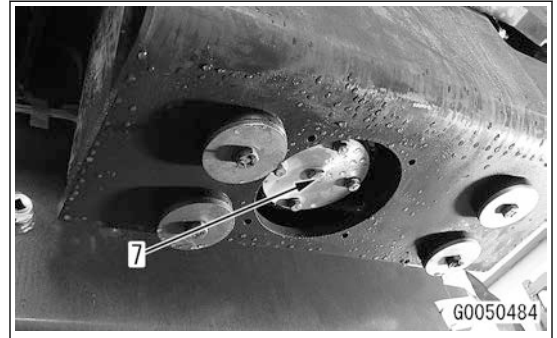

27. Install the cover (2) with the bolts (1) (4 pieces).

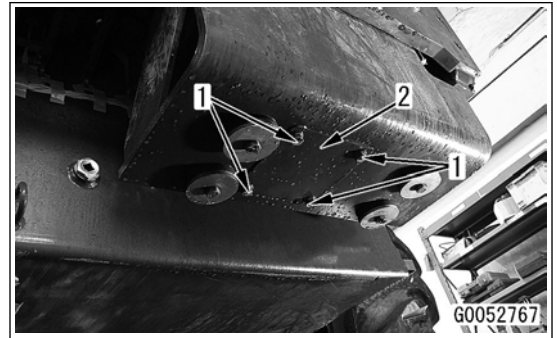

28. Disconnect remote breather hose B from breather hose (5).
29. Connect breather hose (5) to breather block (6).
30. Refill the DEF tank with new DEF.



DEF tank: 37 l

**NOTICE**

**DEF freezes at -11 °C. When adding DEF where the ambient temperature is -11 °C or below, add until it reaches the lowest line. For adding DEF, see Operation and Maintenance Manual, "CHECK AdBlue® LEVEL AND ADD IT".**

Check the refilling amount of DEF through sight gauge.

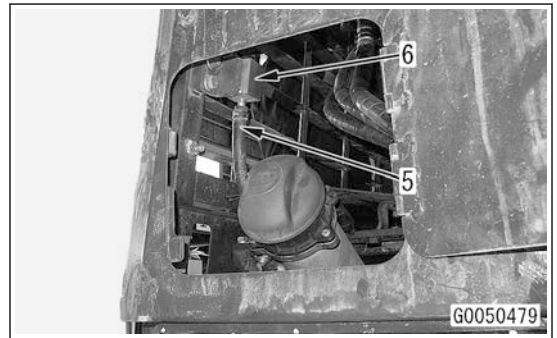

- Set the differential lock switch to the ON position.

**REMARK**

When the differential lock activates, the differential lock pilot lamp comes on.

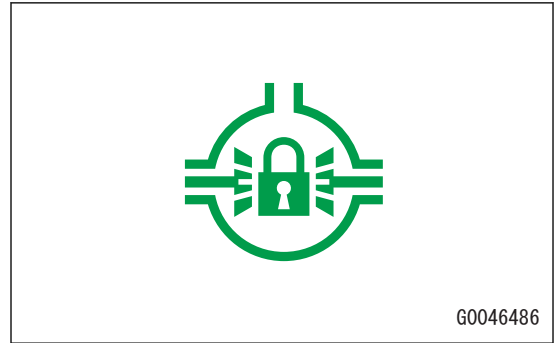
**Check procedure**

- Check the oil pressure when the accelerator pedal is pushed to the stroke end (high idle).  
See Standard Value Table, "Standard Value Table for Machine" for standard values.

**Restoration**

- Stop the engine.
  - ⚠ Immediately after the engine is stopped, the parts and oil become very hot and can cause burn injury. Wait for the temperature to go down, and then start the work.**
- Remove the gauge A1, the nipple A2, the joint A4, the O-ring A5, and elbow D.
- Install pickup plug (2). Restore the machine.
  -  Pickup plug (2): 9.8 to 12.7 Nm {1.0 to 1.3 kgm}

**How to Adjust Differential Lock Oil Pressure**

If the pump discharged pressure or the valve outlet pressure during differential lock is not normal, adjust differential lock relief valve (3) in accordance with the procedures that follow.

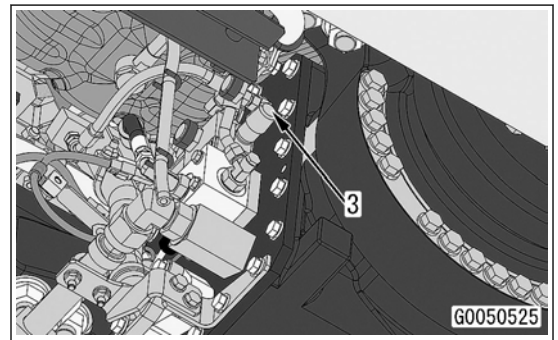

- Remove the orange cap.
- Loosen the lock nut (5) with the adjustment screw (4) fixed.
- Turn the adjustment screw (4) to adjust the oil pressure.
  - Clockwise turn: Pressure increases.
  - Counterclockwise turn: Pressure decreases.

**REMARK**

Quantity of pressure adjustment for each turn of adjustment screw (4): 3.7 MPa {37.8 kg/cm<sup>2</sup>}

- While the adjustment screw (4) is fixed, tighten the locknut (5).

 Lock nut (5): 10 to 15 Nm {1.0 to 1.5 kgm}

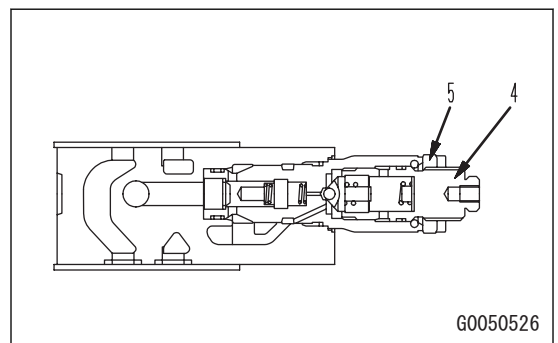

After the adjustment is completed, inspect again to make sure that the pump discharged pressure and valve outlet pressure are normal in response to "TEST DIFFERENTIAL LOCK OIL PRESSURE".

## How to Examine Work Equipment Relief Pressure

### Examine Work Equipment Relief Pressure (Cylinder)

#### Setting the testing device

1. Remove bolts (1) (6 pieces). Remove cover (2) on the right side of the machine.

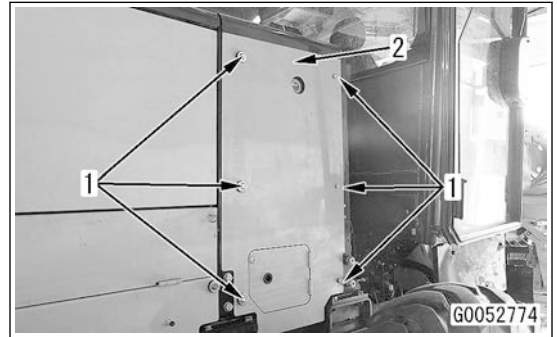

2. Remove the pickup plug of pump discharged pressure pickup port (P1C).

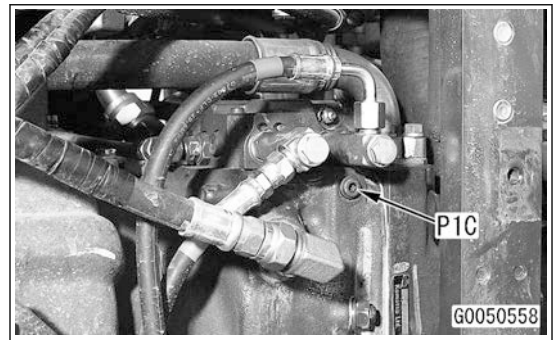

3. Install the nipple C, and connect the gauge A1 in the hydraulic tester A.

 Nipple C: 19.6 to 27.4 Nm {2.0 to 2.8 kgm}

#### REMARK

The gauge in the digital hydraulic tester B can be used in place of the gauge A1.

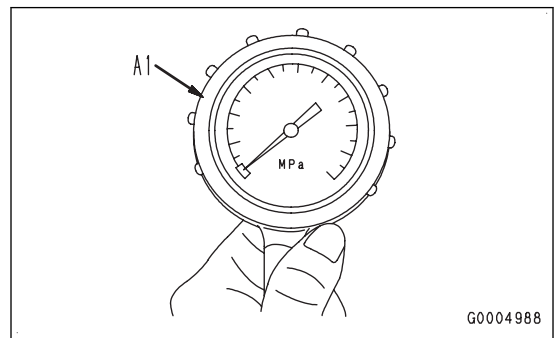
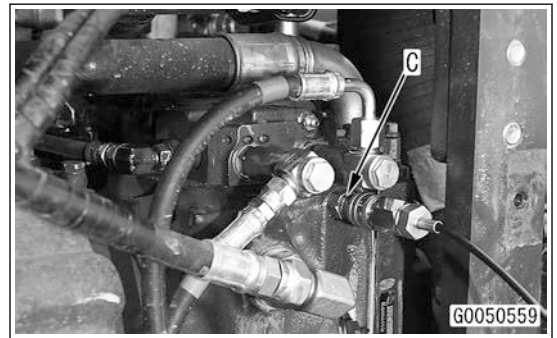

#### Setting of test condition

4. Start the engine.

Contents of work	Required setting/adjustment	Reference
Work equipment controller is replaced	Zero point adjustment for articulate angle	ADJUSTMENT MENU (Zero Point Adjustment For Art Angle)
	Work equipment control lever adjustment	ADJUSTMENT MENU (Work Equipment Control Lever Adjustment)
	IMU adjustment (*1)	ADJUSTMENT MENU (IMU Adjustment)
	Blade rotation angle sensor adjustment (*1)	ADJUSTMENT MENU (Blade rotation angle sensor adjustment)
Work equipment control lever is replaced	Work equipment control lever adjustment	ADJUSTMENT MENU (RH Blade Lift Cylinder Control Lever Adjustment)
		ADJUSTMENT MENU (LH Blade Lift Cylinder Control Lever Adjustment)
		ADJUSTMENT MENU (Blade Side Shift Control Lever Adjustment)
		ADJUSTMENT MENU (Blade Rotation Control Lever Adjustment)
		ADJUSTMENT MENU (Power Tilt Control Lever Adjustment)
		ADJUSTMENT MENU (Drawbar Side Shift Control Lever Adjustment)
		ADJUSTMENT MENU (Leaning Control Lever Adjustment)
		ADJUSTMENT MENU (Articulate Control Lever Adjustment)
		ADJUSTMENT MENU (Ripper/scarifier Control Lever Adjustment)
IMU is replaced (*1)	IMU initial setting	ADJUSTMENT MENU (Machine IMU Parameter Setting)
		ADJUSTMENT MENU (Drawbar IMU Parameter Setting)
	IMU adjustment	ADJUSTMENT MENU (IMU Adjustment)
IMU is removed/installed (*1)	IMU adjustment	ADJUSTMENT MENU (IMU Adjustment)
Blade rotation angle sensor is replaced, removed/installed (*1)	Blade rotation angle sensor adjustment	ADJUSTMENT MENU (Blade rotation angle sensor adjustment)

\*1: For cross slope specification

If you get the feedback or request from user which seems to be applicable to an item in the table below, do the setting or adjustment on the machine monitor.

Feedback/request	Setting/adjustment	Reference
To change the unit display on the speedometer	Unit setting	DEFAULT SETTING MENU (Unit Selection)
Travel speed display is too fast or too slow	Tire size compensation	DEFAULT SETTING MENU (Option Selection)

**Items that Can be Selected with Maintenance Mode Setting**

Code	Item
00	Maintenance Mode Change
49	Air Cleaner Cleaning or Change Interval
60	Coolant Change Interval
41	Fuel Prefilter Change Interval
01	Engine Oil Change Interval
02	Engine Oil Filter Change Interval
13	T/M Oil Filter Change Interval
03	Fuel Main Filter Change Interval
12	T/M Oil Change Interval
15	Axle Oil Change Interval
04	Hydraulic Oil Filter Change Interval
30	Hyd Oil Pilot Filter Change
87	Diff. Lock Oil Filter Change
10	Hydraulic Oil Change Interval
37	Circle Drive Oil Change Interval
99	Restore All to Default Value

**Maintenance Mode Change (Code: 00)**

3. Select "Maintenance Mode Change". On the screen, select the item with the switches on the switch panel.  
 UP switch (10): Moves the selection up by one item.  
 DOWN switch (11): Moves the selection down by one item.  
 RETURN switch (12): Cancels the selection. The screen moves back to the "Maintenance Mode Setting" screen.  
 ENTER switch (13): Validates the selection.

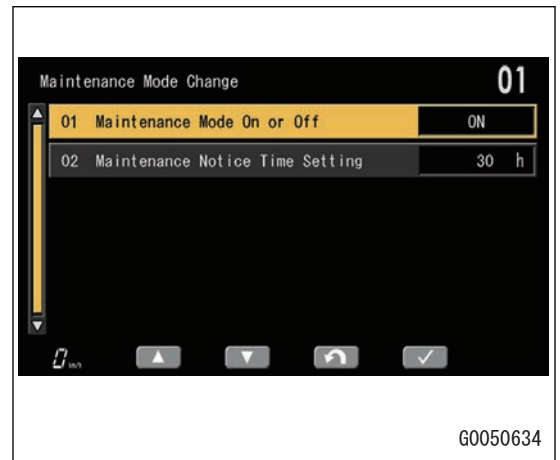

G0050634

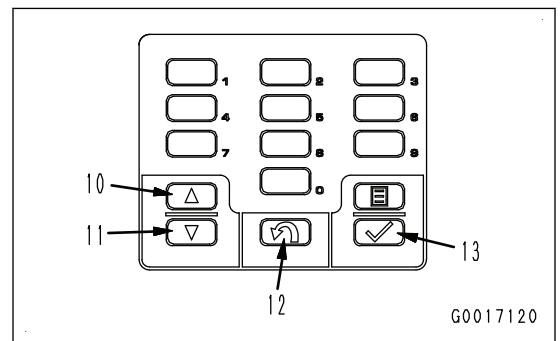

G0017120

- On the “Adjustment Value Check” screen, push the ENTER switch (13) again to reset.

ENTER switch (13): Resets the setting.

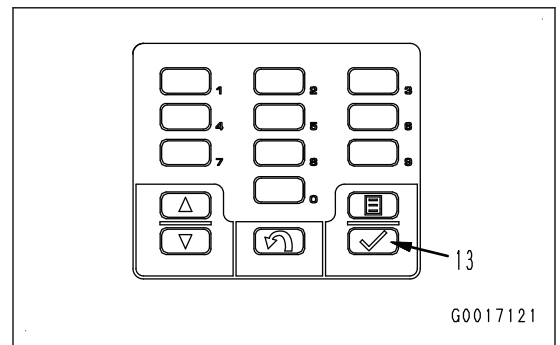
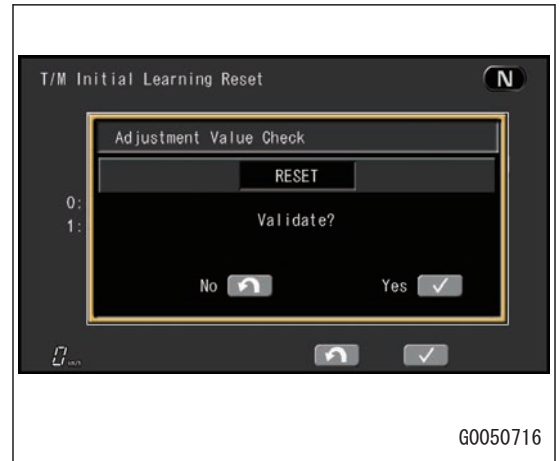

- After you do the reset, make sure that the initialization state (a) is “1: Learning Not Done Yet” and push the RETURN switch (12).

RETURN switch (12): The screen moves back to the “Adjustment” screen.

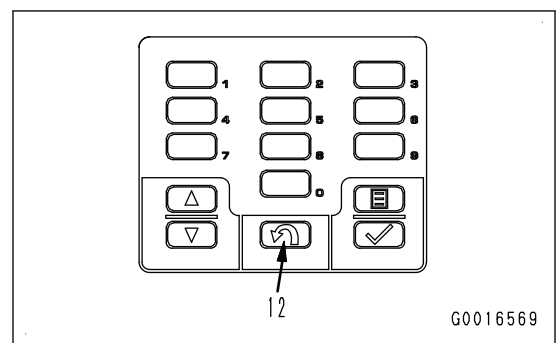
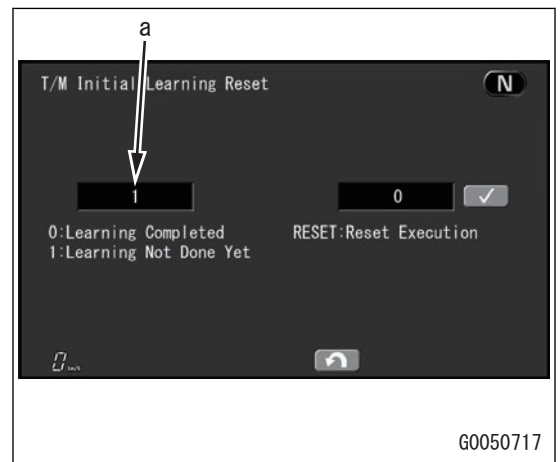

The initial learning data of the transmission has been initialized. Do “T/M Initial Learning” of the adjustment menu.

### Adjustment Menu (Fan 100% Speed Adjustment)

Check and change of the various settings of the machine by the adjustment menu.

- On the “Drawbar IMU Parameter Setting” screen, push the ENTER switch (13) on the switch panel.

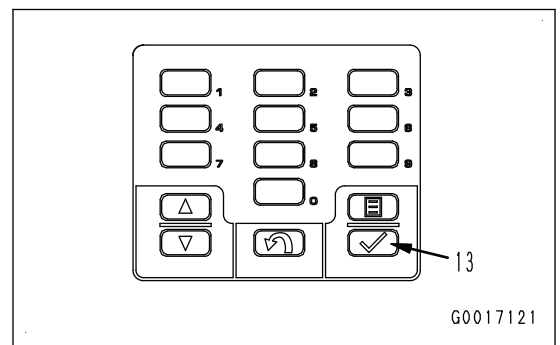
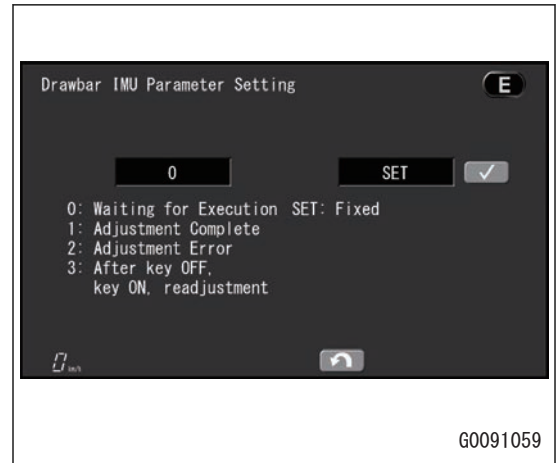

- “1” is shown in (a) part, and the initial setting information is transmitted to the drawbar IMU.

**REMARK**

- When the “2” is shown on (a) part, the adjustment is stopped. When the adjustment is stopped, go back to the “Adjustment”, and do the step 1 and after.
- If the “3” is shown in (a) part, turn the starting switch to the OFF position, then turn it to the ON position again. Do the step 1 and after.

- Turn the starting switch to the OFF position, and then turn the starting switch to the ON position again. The initial setting information is saved in drawbar IMU.

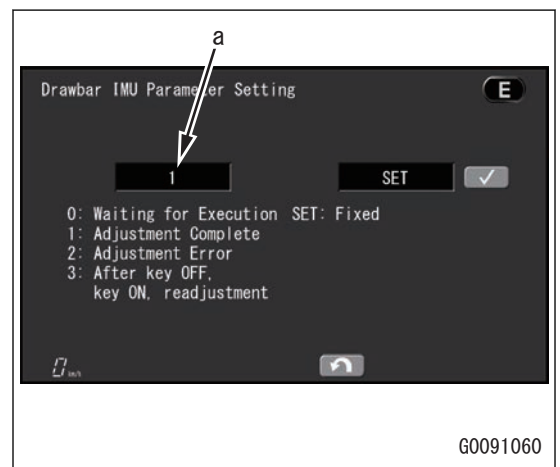

**No-Injection Cranking Operation**

- If you operate the machine when the lubrication has been run out after long-term storage, it scratches or damages the engine. To prevent this, the machine has a function to crank the engine without fuel injection to lubricate the engine.
- Set the no-injection cranking while the engine is stopped.

Failure Code [#Q0059]	40-1913
Failure Code [#Q0060]	40-1916
Failure Code [#Q0061]	40-1919
Failure Code [#Q0062]	40-1922
Failure Code [#Q0063]	40-1925
Failure Code [#Q0064]	40-1928
Failure Code [#Q0065]	40-1933
Failure Code [#Q0066]	40-1936
Failure Code [#Q0067]	40-1939
Failure Code [#Q0068]	40-1942
Failure Code [#Q0069]	40-1945
Failure Code [#Q0070]	40-1948
Failure Code [#Q0071]	40-1951
Failure Code [#Q0072]	40-1954
Failure Code [#Q0073]	40-1959
Failure Code [#Q0074]	40-1964
Failure Code [#Q0075]	40-1967
Failure Code [#Q0076]	40-1970
Failure Code [#Q0077]	40-1973
Failure Code [#Q0078]	40-1976
Failure Code [#Q0079]	40-1979
Failure Code [#Q0080]	40-1982
Failure Code [#Q0081]	40-1985
Failure Code [#Q0082]	40-1988
Failure Code [#Q0083]	40-1991
Failure Code [#Q0084]	40-1994
Failure Code [#Q0085]	40-1997
Failure Code [#Q0086]	40-2000
Failure Code [#Q0087]	40-2003
Failure Code [#Q0088]	40-2006
Failure Code [#Q0089]	40-2009
Failure Code [#Q0090]	40-2012
Failure Code [#Q0091]	40-2015
Failure Code [#Q0092]	40-2018
Failure Code [#Q0093]	40-2021
Failure Code [#Q0094]	40-2024
Failure Code [#Q0095]	40-2027
Failure Code [#Q0096]	40-2030
Failure Code [#Q0097]	40-2033
Failure Code [#Q0098]	40-2036
Failure Code [#Q0099]	40-2041
Failure Code [#Q0100]	40-2047
Failure Code [#Q0101]	40-2050
Failure Code [#Q0102]	40-2053
Failure Code [#Q0103]	40-2057
Failure Code [#Q0104]	40-2061
Failure Code [#Q0105]	40-2065
Failure Code [#Q0106]	40-2068
Failure Code [#Q0107]	40-2071
Failure Code [#Q0108]	40-2074
Failure Code [#Q0109]	40-2077
Failure Code [#Q0110]	40-2081
Failure Code [#Q0501]	40-2082
Failure Code [#Q0502]	40-2083
Failure Code [#Q0503]	40-2084
Failure Code [#Q0504]	40-2087
Failure Code [#Q0505]	40-2090
Failure Code [#Q0506]	40-2093

2. Open the cover (1) at the right of the machine.
3. Remove the cap of the oil filler port (F).
4. Pull out the dipstick (G) and wipe the oil off with a cloth.

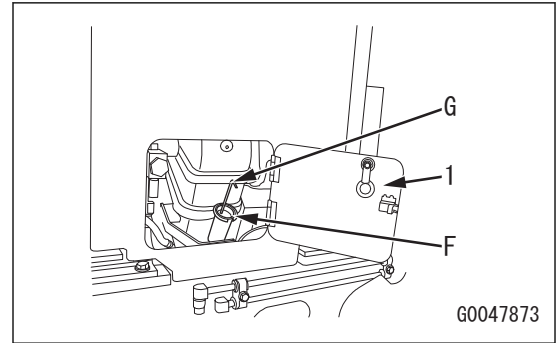

5. Fully put the dipstick (G) into the dipstick pipe, then pull it out.  
If the oil level is between marks H and L of the dipstick (G), it is correct.

**REMARK**

The oil levels that follow are stamped on each side of the dipstick (G).

- (A) Engine stop state (ENG STOP)
- (B) Engine idling state (ENG IDLING)

Use the mark of the (A) engine stop state (ENG STOP).

6. If the oil level is below L mark, add oil through the oil filler port (F).

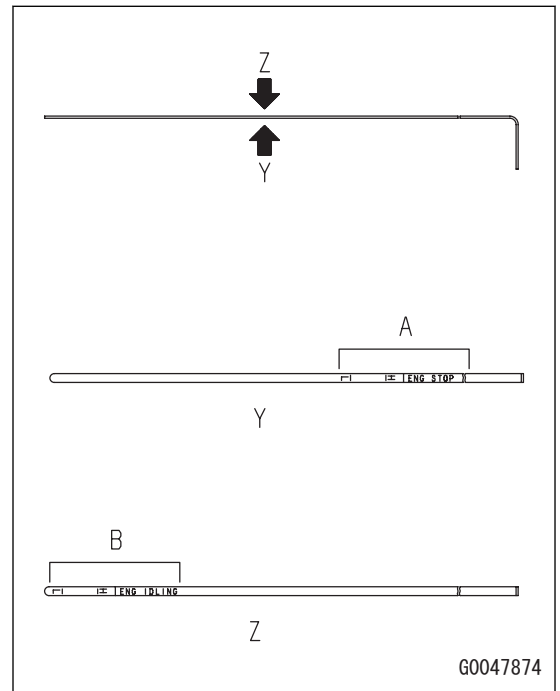

7. If the oil level is above H mark, remove the drain plug (2), and loosen the drain plug (3) to drain excessive oil.

Tightening torque

Drain plug (2): 58.8 to 78.5 Nm {6 to 8 kgm}

Drain plug (3): 49 to 78.5 Nm {5 to 8 kgm}



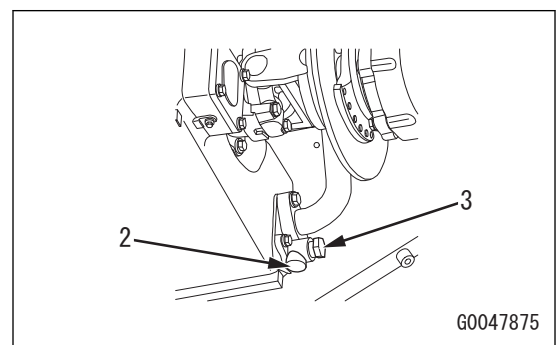



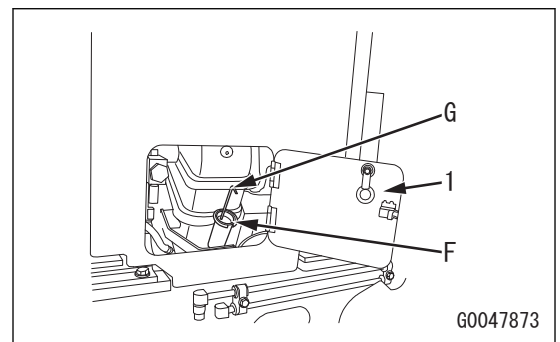

8. Check the oil level again.

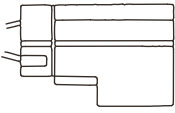

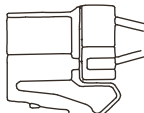
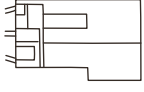
9. If the oil is at the correct level, insert the dipstick (G) into the dipstick pipe.
10. Tighten the cap of the oil filler port (F) securely.
11. Close the cover (1).

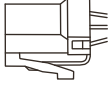
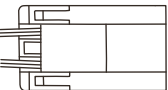

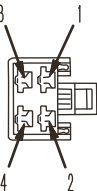
Connector No.	Connector type	Number of pins	Location	Address
ET39	DT	2	Fuel sensor	E-11
ET40A	Terminal	1	Breaker	A-8
ET40B	Terminal	1	Ground	D-39
ET41A	Terminal	1	Battery	A-9
ET41B	Terminal	1	Breaker	A-8
ET42	Terminal	1	Battery	A-8
ET43	Terminal	1	Battery	A-8
ET44	Terminal	1	Battery	A-7
ET45	Terminal	1	Battery relay	B-1
ET46	Terminal	1	Battery relay	B-1
ET47	Terminal	1	Slow-blow fuse	A-1
ET48	Terminal	1	Slow-blow fuse	A-1
ET49	Terminal	1	Battery relay	B-3
ET54	Terminal	1	Heater relay	D-12
ET55	Terminal	1	Heater relay	E-11
ET58	Terminal	1	Battery relay	B-3
ET59	Terminal	1	Slow-blow fuse	A-3
ET60	Terminal	1	Slow-blow fuse	A-2
ET75	Terminal	1	Battery relay	C-1
ET76	Terminal	1	Battery relay	C-1
ET82	Terminal	1	Heater relay	E-12
ET88	DT	2	Compressor magnetic clutch	A-9
ET89	Terminal	1	Ground	F-9
ET104	DT	2	Intermediate connector	H-8
FB1	-	15	Fuse box	H-21
FB2	-	15	Fuse box	G-21
FB3	-	10	Fuse box	F-30
FB4	-	10	Fuse box	A-15
FL1	DT	3	Headlamp (R.H.)	F-1
FL2	DT	3	Headlamp (L.H.)	I-3
FL3	DT	3	Front combination lamp (R.H.)	F-1
FL4	DT	3	Front combination lamp (L.H.)	I-2
FL5	DT	2	Side marker (R.H.)	G-1
FL6	DT	2	Side marker (L.H.)	I-3
FL6	DT	3	Inching pedal	I-16
FL9	DT	2	Front working lamp (L.H.)	H-6
FL10	DT	2	Front working lamp (R.H.)	H-6

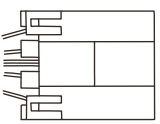
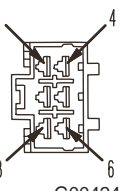
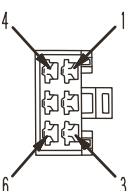
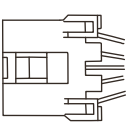
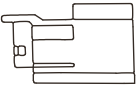
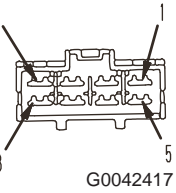
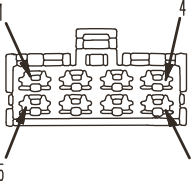
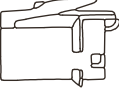
Total number of pins	M type connector		Special tool number for connection checks
	Male (concave engaging portion)	Female (convex engaging portion)	
1	Part No.: 08056-00171	Part No.: 08056-00181	799-601-7080 (T-branch)
2	  <p>G0042409</p>	  <p>G0042410</p>	799-601-7090 (T-branch)
	Part No.: 08056-00271	Part No.: 08056-00281	
3	  <p>G0042411</p>	  <p>G0042412</p>	799-601-7110 (T-branch)
	Part No.: 08056-00371	Part No.: 08056-00381	
4	  <p>G0042413</p>	  <p>G0042414</p>	799-601-7120 (T-branch)
	Part No.: 08056-00471	Part No.: 08056-00481	
6	  <p>G0042415</p>	  <p>G0042416</p>	799-601-7130 (T-branch)
	Part No.: 08056-00671	Part No.: 08056-00681	
8	  <p>G0042417</p>	  <p>G0042418</p>	799-601-7340 (T-branch)
	Part No.: 08056-00871	Part No.: 08056-00881	



Failure code	Failure (Displayed on screen)	Applicable component	Action level	Category of history	Remarks
F31EKY	24V Sensor Power Supply Booster Output Hot Short Circuit (Gateway Controller)	GW	-	Electrical system	
FS10ZE	Engine Controller Remote Access Abnormality	GW	-	Electrical system	
#Q0001	Abnormality of Temperature Sensor1 (S/T)	TM	L03	Electrical system	
#Q0002	Abnormality of Temperature Sensor2 (S/T)	TM	L03	Electrical system	
#Q0003	Abnormality of Vbat 1 (S/T)	TM	L03	Electrical system	
#Q0004	Abnormality of Vbat 2 (S/T)	TM	L03	Electrical system	
#Q0005	Abnormality of Vbat 3 (S/T)	TM	L03	Electrical system	
#Q0006	Abnormality of Cut-Off supply 1 (S/T)	TM	L03	Electrical system	
#Q0007	Abnormality of Cut-Off supply 2 (S/T)	TM	L03	Electrical system	
#Q0008	Abnormality of Cut-Off supply 3 (S/T)	TM	L03	Electrical system	
#Q0009	Abnormality of Cut-Off supply 4 (S/T)	TM	L03	Electrical system	
#Q0010	Abnormality of Cut-Off supply 5 (S/T)	TM	L03	Electrical system	
#Q0011	Abnormality of SASAID sensor 1 (S/T)	TM	L03	Electrical system	
#Q0012	Abnormality of SASAID sensor 2 (S/T)	TM	L03	Electrical system	
#Q0013	Abnormality of SASAID sensor 3 (S/T)	TM	L03	Electrical system	
#Q0014	Abnormality of SASAID sensor 4 (S/T)	TM	L03	Electrical system	
#Q0015	Abnormality of VSS 1 (S/T)	TM	L03	Electrical system	
#Q0016	Abnormality of VSS 2 (S/T)	TM	L03	Electrical system	
#Q0017	Abnormality of VSS 3 (S/T)	TM	L03	Electrical system	
#Q0018	Abnormality of VSS 4 (S/T)	TM	L03	Electrical system	
#Q0019	Abnormality of MMI 1 (S/T)	TM	L03	Electrical system	
#Q0020	Abnormality of MMI 2 (S/T)	TM	L03	Electrical system	
#Q0021	Abnormality of MMI 3 (S/T)	TM	L03	Electrical system	

No.	Cause	Procedure, measurement position, standard (value), notes		
5	Defective transmission controller	If no failure is found by the previous checks, the transmission controller is defective. (Since this is an internal defect, troubleshooting cannot be done.)		
		<ul style="list-style-type: none"> <li>• Reference</li> <li>1. Starting switch OFF</li> <li>2. Lift the machine so that the drive wheels can turn freely.</li> <li>3. Insert the T-adapter to connector TM40.</li> <li>4. Start the engine.</li> </ul> <p><b>REMARK</b> For the procedure to turn the drive wheels freely, see Testing and Adjusting, "Examine Power Train Oil Pressure".</p>		
		Voltage	Between TM40 (2) and ground	Directional selector switch: N
		Between TM40 (2) and ground	<ul style="list-style-type: none"> <li>• Let drive wheels turn freely</li> <li>• Directional selector switch F, or R</li> <li>• Gear speed: F5, F6 or R3</li> </ul>	Max. 1 V

**Circuit Diagram of 3rd Clutch**

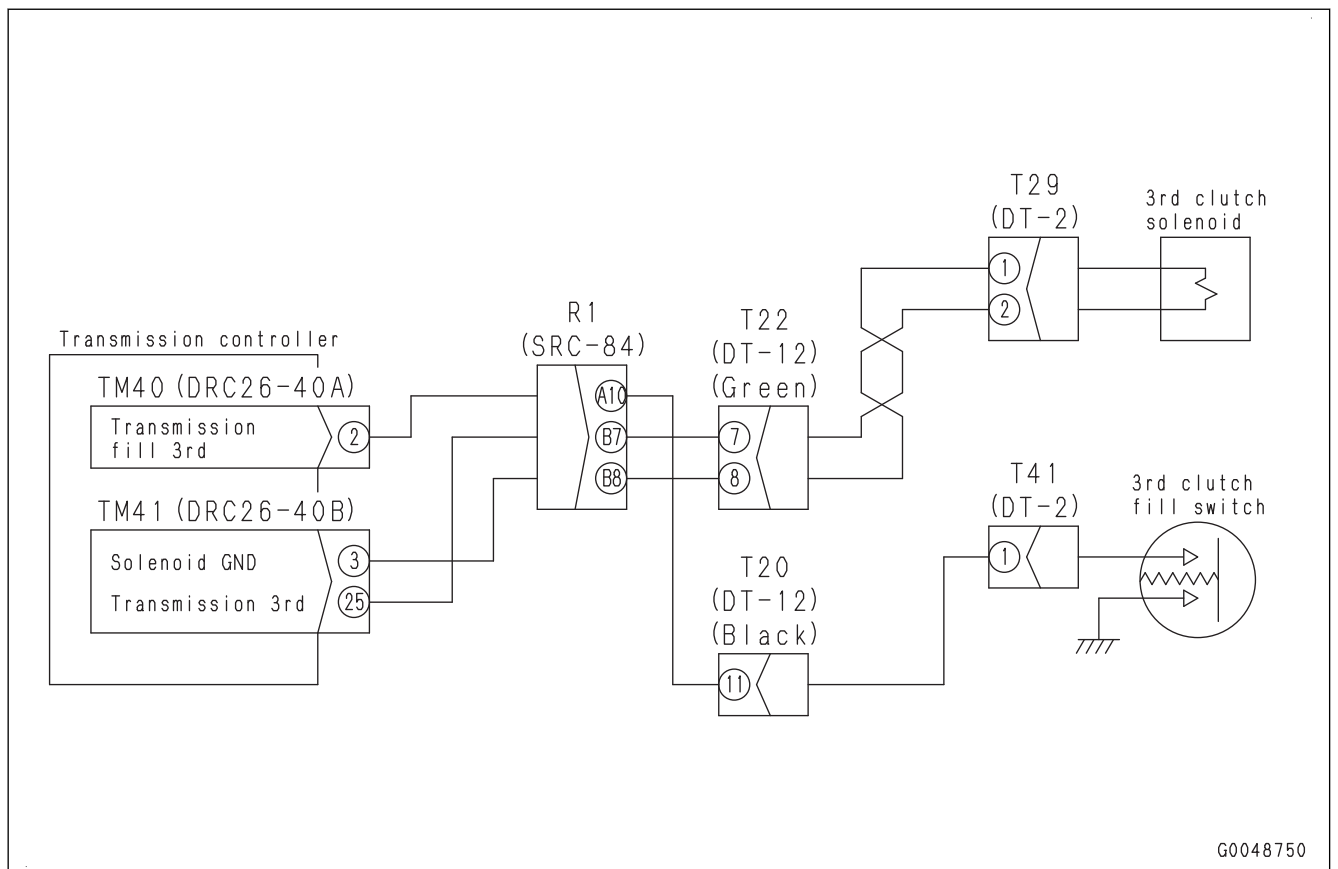

**Failure Code [B@BCNS]**

Action level	Failure code	Failure	Engine Coolant Overheat (Engine controller system)
L02	B@BCNS		
Details of failure	Engine controller determines engine coolant temperature overheat when voltage from engine coolant temperature sensor drops while engine is running.		
Action of controller	<ul style="list-style-type: none"> <li>Lights up engine coolant temperature monitor in red on machine monitor.</li> <li>Engine power deration.</li> </ul>		
Phenomenon on machine	<ul style="list-style-type: none"> <li>Engine power deration.</li> <li>If machine is used as it is, engine may be seized.</li> </ul>		
Related information	<ul style="list-style-type: none"> <li>Signal voltage of engine coolant temperature sensor is input to engine controller that transmits information to machine monitor through CAN communication system.</li> <li>Engine coolant temperature can be checked with monitoring function (Code: 04107)</li> <li>After repairing, check if the failure code is cleared by the following procedure. Procedure: Start engine.</li> </ul>		

No.	Cause	Procedure, measuring location, criteria and remarks
1	Overheat of engine coolant (when system works properly)	Engine coolant may overheat. Check coolant temperature and remove cause of failure if engine coolant overheats.
2	Defective engine coolant temperature sensor system	If failure code is still displayed after above checks on cause 1, engine coolant temperature sensor system may be defective. Perform troubleshooting for failure codes [CA144] and [CA145].

### Circuit Diagram of IMV/PCV1

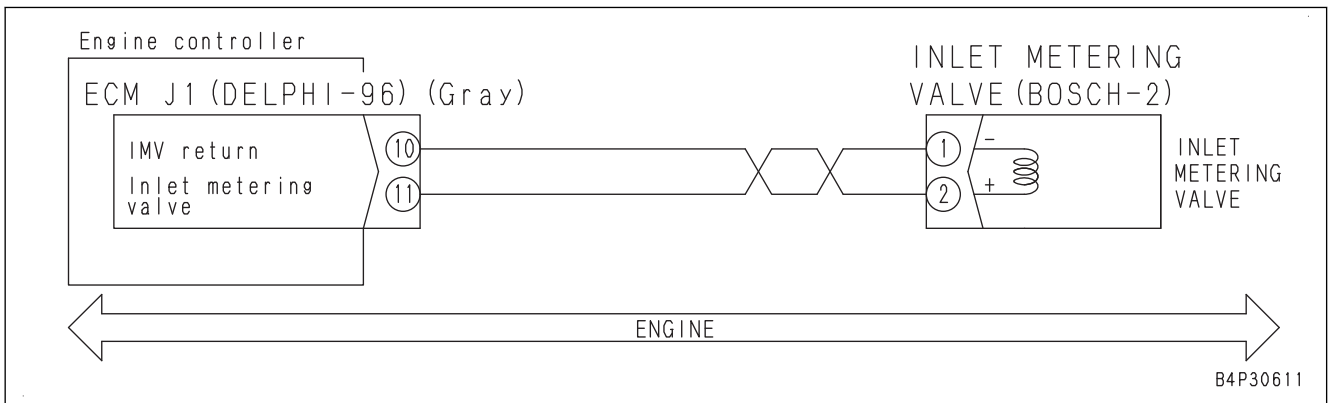

**Failure Code [CA516]**

Action level	Failure code	Failure	Common Rail Pressure Sensor Supply Voltage Low Error (Engine controller system)
L03	CA516		
Detail of failure	Low voltage occurs in power supply (5 V) of common rail pressure sensor.		
Action of controller	<ul style="list-style-type: none"> <li>• Engine power deration.</li> <li>• Restricts common rail pressure.</li> </ul>		
Phenomenon on machine	Engine power deration.		
Related information	<ul style="list-style-type: none"> <li>• After repairing, check if the failure code is cleared by the following procedure. Procedure: Turn the starting switch to ON position.</li> <li>• Because female connector alone is provided in “Socket” for troubleshooting for this sensor, check for open circuit in wiring harness and voltage check cannot be performed (T-adaptor is not provided).</li> </ul>		

No.	Cause	Procedure, measuring location, criteria and remarks	
1	Defective wiring harness connector	1. See descriptions of wiring harness and connectors in “Electrical equipment” in “CHECKS BEFORE TROUBLESHOOTING” of “RELATED INFORMATION ON TROUBLESHOOTING”, and check it. 2. Turn starting switch to ON position.	
		If this failure code is cleared, harness connector is defective.	
2	Defective common rail pressure sensor (internal defect)	1. Turn starting switch to OFF position. 2. Disconnect connector FUEL RAIL PRESS. 3. Turn starting switch to ON position.	
		If this failure code is cleared any more, sensor is defective. <b>REMARK</b> Other failure codes are displayed at the same time. This happens because the connector is disconnected. So ignore other codes than this failure code.	
3	Defective wiring harness	1. Turn starting switch to OFF position. 2. Disconnect connector ECM J1. 3. Turn starting switch to ON position.	
		If this failure code is cleared, wiring harness system may be defective. perform following diagnosis. <b>REMARK</b> Many other failure codes appear at same time because of disconnected connector. Ignore failure codes other than this.	
4	Ground fault in wiring harness (contact with ground circuit)	If failure code is still displayed after above checks on cause 3, this check is not required. 1. Starting switch: OFF 2. Disconnect connectors ECM J1, and connect T-adaptor to female side of ECM J1.	
		Resistance	Between ECM J1 (female) (42) and ground

**Failure Code [CA1694]**

Action level	Failure code	Failure	SCR Outlet NOx Sensor In Range Error (Engine controller system)
L01	CA1694		
Detail of failure	The value of the NOx sensor of the SCR outlet is abnormal compared with the turbocharger outlet NOx emission value		
Action of controller	None in particular		
Phenomenon on machine	NOx emission may increase or ammonia may be exhausted because DEF injection works inappropriately.		
Related information	<p><b>⚠ SCR assembly, sensor fitting piping, and sensor probe become hot (Min. 400 °C). Be careful not to get burned.</b></p> <p><b>⚠ Be careful not to get burned by the sensor probe as it is heated by itself even if the ambient temperature is not high.</b></p> <ul style="list-style-type: none"> <li>If the SCR outlet NOx sensor probe is disconnected from the exhaust pipe or loosened, this failure code may appear.</li> <li>The SCR outlet NOx sensor and turbocharger outlet NOx sensor are not serviceable, therefore, replace the sensor if it is defective.</li> </ul> <p><b>NOTICE</b></p> <ul style="list-style-type: none"> <li><b>For this failure code, after investigating the cause of the problem and completing the repair, perform “Loaded Diagnostics Operation To Confirm Failure Correction” to make sure repair is completed. (This failure code is not cleared by only turning ON the starting switch.)</b></li> <li><b>If the failure code of active regeneration prohibition or that of DEF injection prohibition is displayed, the failure cannot be cleared. Clear the corresponding failure codes first.</b></li> </ul>		

No.	Cause	Procedure, measuring location, criteria and remarks
1	Defective turbocharger outlet NOx sensor system (Open circuit, internal defect, defective sensor heater)	If failure code [CA1885], [CA3232], [CA3649], [CA3682], [CA3718], [CA3725], or [CA3748] is displayed, perform troubleshooting for these failure codes first.
2	Defective SCR outlet NOx sensor system (Open circuit, internal defect, defective sensor heater)	If failure code [CA1887], [CA2771], [CA3545], [CA3583], [CA3681], or [CA3717] is displayed, perform troubleshooting for these failure codes first.
3	Defective connection between the SCR outlet NOx sensor probe and an exhaust pipe	Check if the SCR outlet NOx sensor probe is installed securely.
4	Accumulation of urea deposits in DEF mixing tube	<ol style="list-style-type: none"> <li>Check if urea deposits are accumulated in the DEF mixing tube and the DEF injector mount.</li> <li>If deposits are accumulated, remove the DEF mixing tube to remove deposits and clean the tube.</li> <li>Check if urea deposits are accumulated in the SCR inlet case. If accumulated, perform the next item.</li> </ol>

No.	Cause	Procedure, measuring location, criteria and remarks
2	KCSF failure 1	<ol style="list-style-type: none"> <li>1. Turn the starting switch to OFF position, then turn the starting switch to ON again.</li> <li>2. Check if a failure code other than [CA1993] is displayed.</li> <li>3. Start the engine and suddenly accelerate it from low idle to high idle two times, then keep the engine running at high idle speed for 5 seconds. At this point, check the color of exhaust gas at the exhaust pipe section during sudden acceleration and high idle.</li> <li>4. If black smoke comes out of the exhaust pipe after performing 3., KCSF is defective. Check KCSF for existence, damages or contamination by foreign materials. Repair it if necessary.</li> </ol> <p><b>NOTICE</b> Perform checks on cause 3 and subsequent causes if no black smoke is detected.</p>
3	Defective KDPF differential pressure sensor tube	<p>Check if:</p> <ol style="list-style-type: none"> <li>1. the KDPF differential pressure sensor tube is present,</li> <li>2. the KDPF differential pressure sensor tube is not connected improperly,</li> <li>3. the removed KDPF differential pressure sensor tube for clogging, cracks, or damages, or</li> <li>4. the both ends of the KDPF differential pressure sensor tube is not loose.</li> <li>5. Perform "Loaded Diagnostics Operation To Confirm Failure Correction".</li> </ol>
4	KCSF failure 2	<ol style="list-style-type: none"> <li>1. If this failure code is displayed again after preceding procedures are implemented, remove KDPF, then remove KCSF, and check filters for existence, damages or contamination by foreign materials. Repair it if necessary.</li> <li>2. Perform "Loaded Diagnostics Operation To Confirm Failure Correction".</li> <li>3. Perform repair again from cause 1 if this failure code is displayed again after "Loaded Diagnostics Operation To Confirm Failure Correction" has been performed.</li> </ol>
5	Defective engine controller	If no failure is found by above checks, engine controller is defective. (Since this is an internal defect, troubleshooting cannot be performed.)

### Loaded Diagnostics Operation to Confirm Failure Correction

Perform the procedure below to check that the repair is completed.

(Make sure that this failure code is cleared after this procedure.)

#### REMARK

If this failure code is displayed during "Loaded Diagnostics Operation To Confirm Failure Correction", return to troubleshooting.

**▲ Place the machine on a level ground, set the gear shift lever to "PARKING (P)" position, and check the tires.**

1. Turn the starting switch to ON position.
2. Clear this failure code by "Engine Controller Active Fault Clear" from "SERVICE MODE" of the machine monitor.
3. Turn the starting switch to OFF position, and shut down the engine controller.
4. Turn the starting switch to ON position, and start the engine.
5. Run the engine at low idle speed for approximately 1 minute.
6. Stall torque converter continuously for approximately 60 seconds as described below with accelerator pedal position 100 %.
  - 1) Check that gear shift lever is in "PARKING (P)" position.

### Circuit diagram of SCR system CAN communication

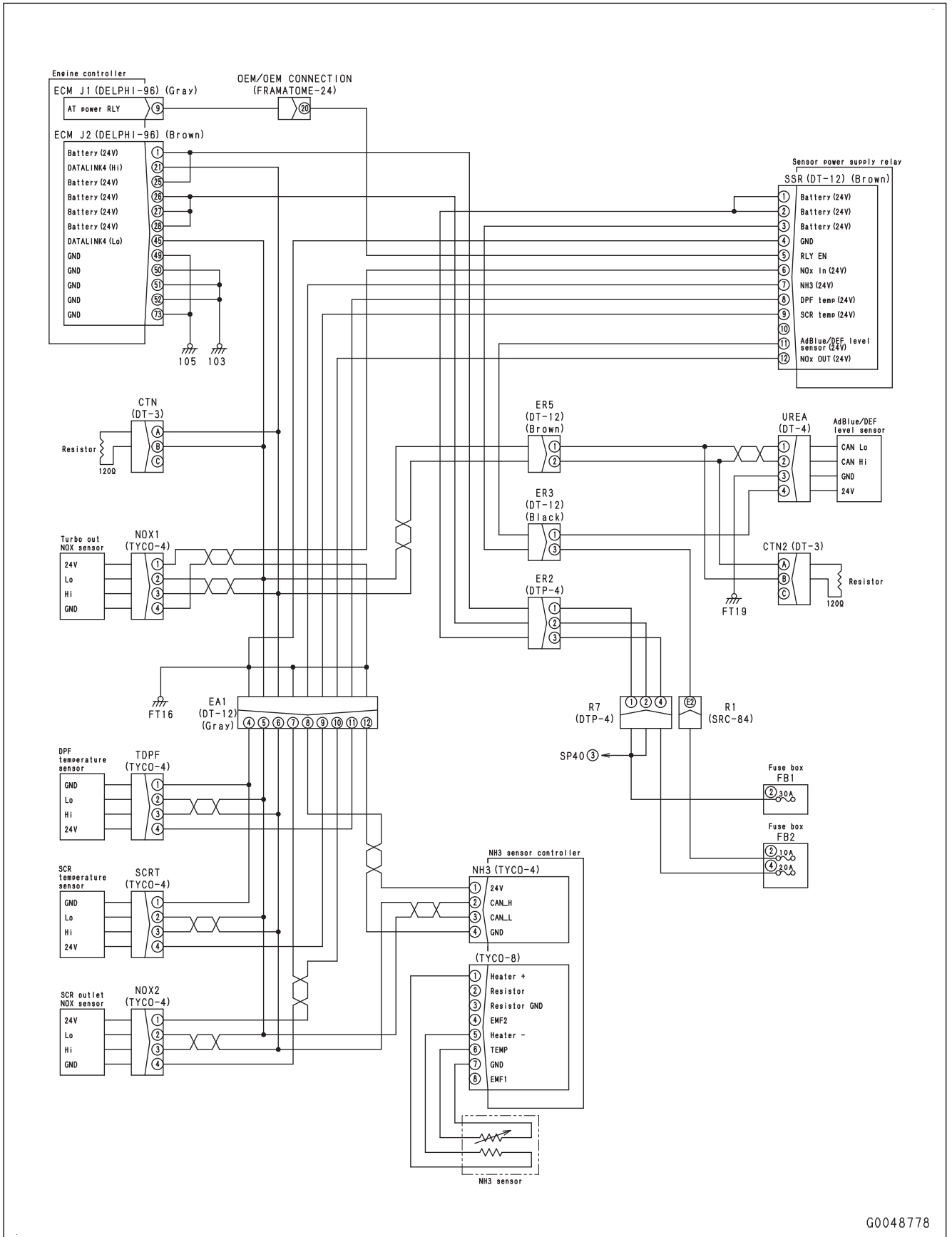

G0048778

### Circuit Diagram of DEF Line Heater

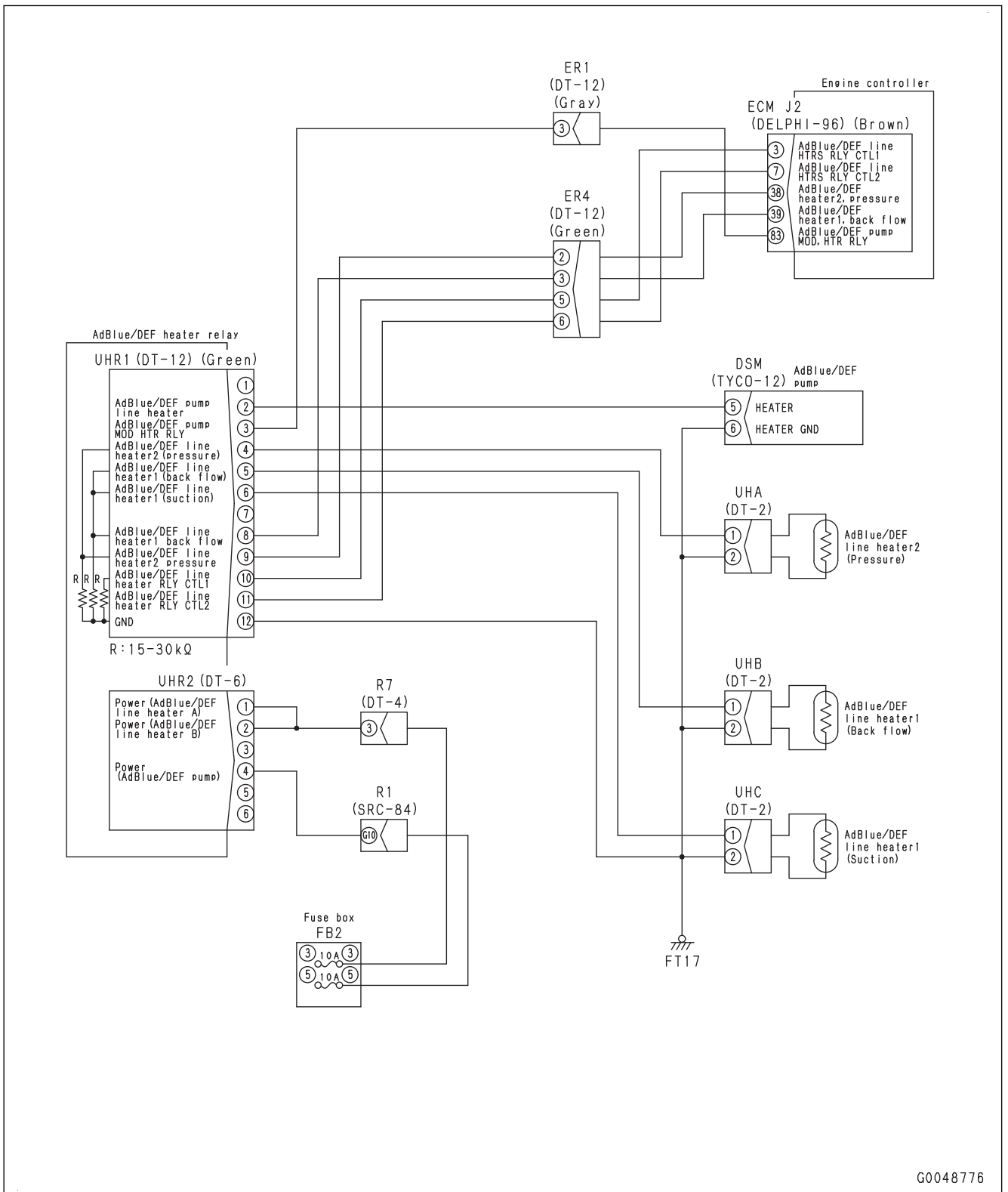

G0048776

No.	Cause	Procedure, measuring location, criteria and remarks
5	Improper DEF quality	<ol style="list-style-type: none"> <li>1. Check the mounting of the DEF quality sensor is secured and the wiring harness connections are not loosen Repair if any abnormality is found.</li> <li>2. Turn starting switch to ON position.</li> <li>3. Check if failure code [CA3866] or [CA3867] is displayed.</li> <li>4. Read 19100 “ DEF concentration ” on the display and confirm that the concentration is appropriate (29 to 36 %).</li> <li>5. If failure code [CA3866] or [CA3867] is displayed and the 19100 “ DEF concentration ” reading is inappropriate, drain the DEF tank, clean the tank, and refill with genuine DEF.</li> <li>6. Perform “Loaded Diagnostics Operation To Confirm Failure Correction” to check if this failure code is not cleared.</li> <li>7. If the 19205 “ Ammonia concentration (compensation value) ” reading is normal (5 to 100 ppm) and the failure code is not redisplayed, the repair is completed.</li> <li>8. If the ammonia concentration indicates an abnormal value or this failure code recurs, proceed to the next step.</li> </ol>
6	Clogged DEF injector	<ol style="list-style-type: none"> <li>1. If failure code [CA4658] or [CA3568] is displayed, or failure code [CA4658] or [CA3568] is displayed on the service meter display of the abnormality record within 2 hours, perform “Loaded Diagnostics Operation To Confirm Failure Correction”, check if failure code [CA3151], [CA3543], or [CA3582] is displayed.</li> <li>2. If 19205 “ Ammonia concentration (compensation value) ” indicates a normal value (5 to 100 ppm) and the failure code is cleared, the repair is completed (“Loaded Diagnostics Operation To Confirm Failure Correction” has resolved the clogging problem and the machine has restored normal operation).</li> <li>3. If the ammonia concentration indicates an abnormal value or either failure code [CA3151], [CA3543], or [CA3582] is displayed, proceed to the next step.</li> </ol>
7	Defective mixing tube (exhaust gas leakage)	<ol style="list-style-type: none"> <li>1. Visually check the piping from the KDPF outlet to the SCR outlet for damage or defective connection.</li> <li>2. Visually check for white crystallized DEF deposits on the surrounding area.</li> <li>3. If defective connections or damages are found, fix or replace parts.</li> </ol>
8	Damaged DEF hose, DEF leakage at connection	<p>If crystallized DEF is adhered to the surrounding of hose, tank, pump, or engine compartment, it shows DEF may be leaking. Refer to “TESTING AND ADJUSTING”, “SETTING AND OPERATION OF MACHINE MONITOR”, “METHOD FOR SETTING WITH TESTING MENU (SCR SERVICE TEST)” to perform DEF Pump Pressure Up Test and find the location of the DEF leak.</p> <p>Replace parts as necessary.</p>

**Failure Code [CA3596]**

Action level	Failure code	Failure	DEF Pump Pressure Unstable Error (Engine controller system)
L01	CA3596		
Detail of failure	A failure of the DEF pump pressure sensor, clogging of each DEF hose, or DEF pump is found.		
Action of controller	Advances to Inducement strategy.		
Phenomenon on machine	Engine power deration according to inducement strategy.		
Related information	<ul style="list-style-type: none"> <li>• For the inducement failure codes, refer “List of failure codes related to Inducement” of “Troubleshooting Points for Urea SCR System”.</li> <li>• The engine controller does not display this failure code during thawing control of the DEF supply system (DEF injection is disabled, which disables judgment).</li> <li>• Make sure that the value of the following 4 states are other than 1 (Thawing) 3 minutes after the engine is started. (This failure cannot be repaired until thawing control is completed)</li> <li>• The state of each heater is 1: Thawing, 2: Warming, or 0: OFF. (Enter the numbers directly and confirm the values on the monitoring code screen.)</li> <li>• 19305 DEF Tank Heating State 19306 DEF suction and purge line heater state 19307 DEF pressure line heater state 19308 DEF pump heater state</li> <li>• This failure code is cleared if the DEF pump pressure rises to around 900 kPa on the DEF pump “ Pre-defined Monitoring screen ”.</li> <li>• The “ Pre-defined Monitoring screen ” uses the DEF pump diagnosis. (The following numbers are the monitoring codes)</li> <li>• DEF pump diagnosis 19304 DEF pump state 19108 DEF Pump Pressure 19136 DEF Pump Temperature 19109 DEF Pump Pressure Sensor Voltage 19120 DEF Injection Quantity</li> </ul> <p><b>NOTICE</b>  <b>This failure code requires a inducement error and “Loaded Diagnostics Operation To Clear Failure Code”. After investigating the cause of the problem and completing the repair, perform a“Loaded Diagnostics Operation To Clear Failure Code” to make sure the failure code is cleared.(This failure code is not cleared by only turning starting switch to ON position.)</b></p>		

No.	Cause	Procedure, measuring location, criteria and remarks
1	Defective wiring harness connector	<ol style="list-style-type: none"> <li>1. See descriptions of wiring harness and connectors in “Electrical equipment” in “CHECKS BEFORE TROUBLESHOOTING” of the failure code “RELATED INFORMATION ON TROUBLESHOOTING”, and check it.</li> <li>2. Turn starting switch to ON position.</li> </ol> <p>If this failure code is cleared, wiring harness connector is defective.</p>

### Circuit diagram of SCR system CAN communication

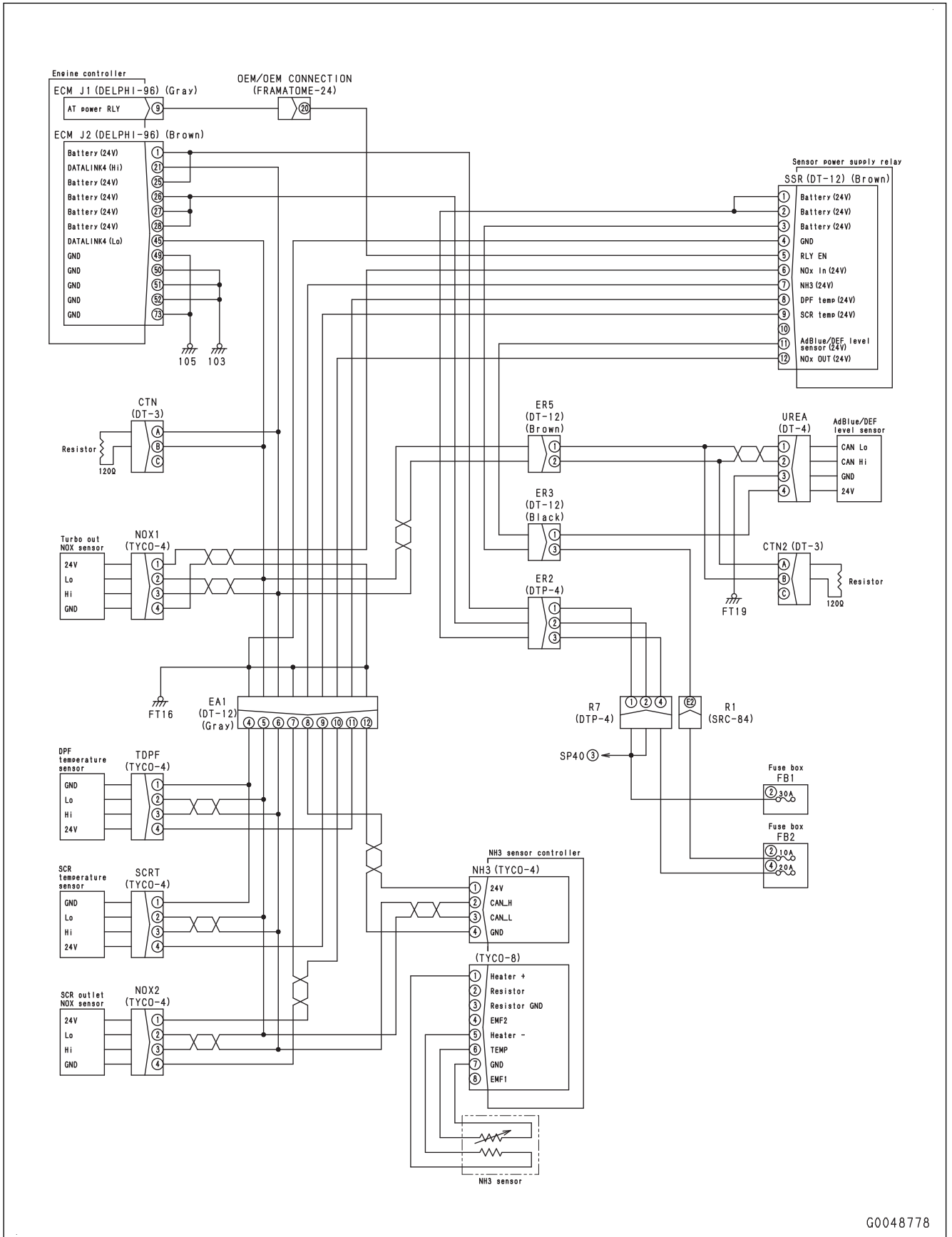

G0048778

### Electrical Circuit Diagram of DEF Pump Heater

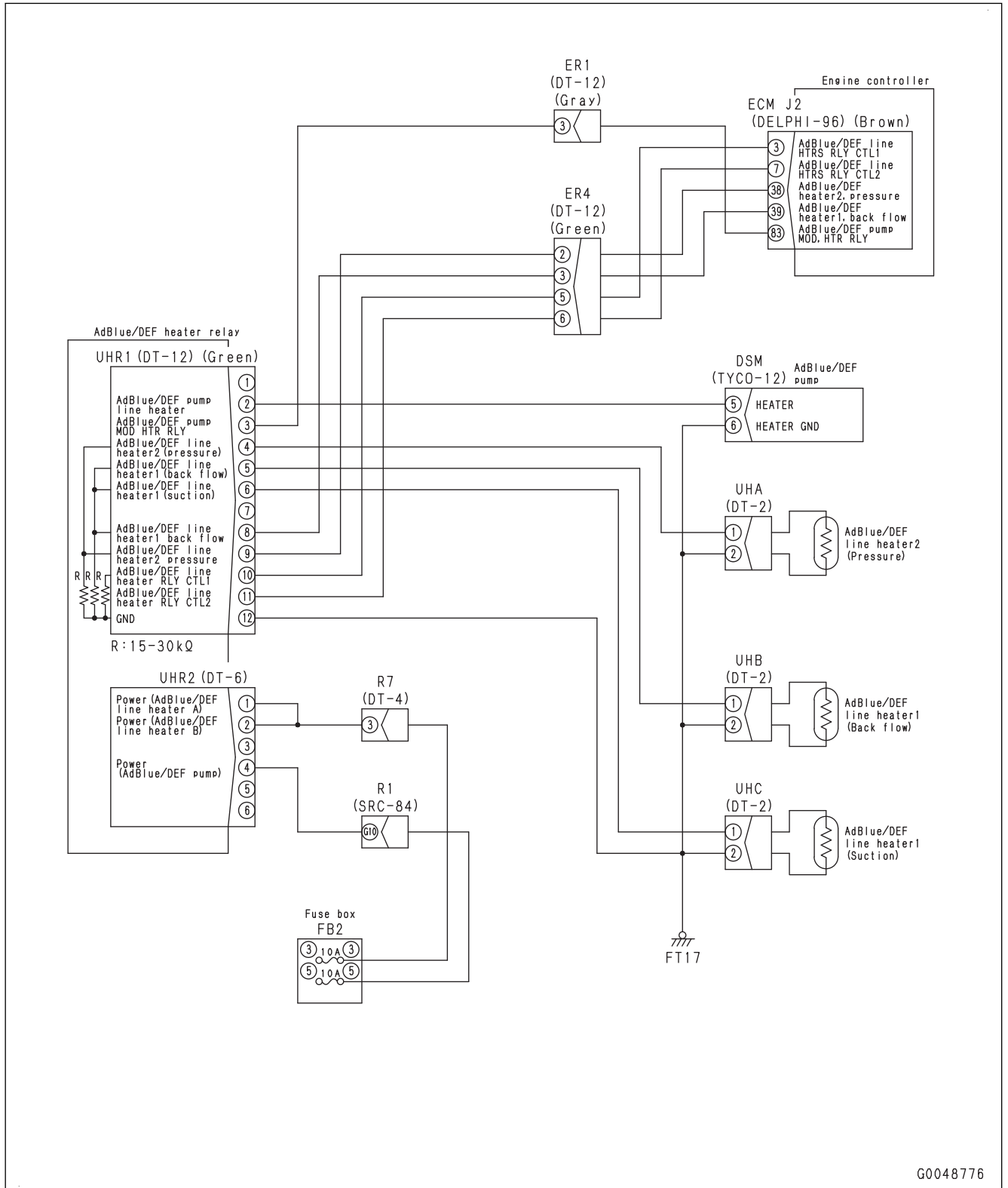

G0048776

## Failure Code [CA4952] (Machine with Gateway Function Controller) (Applicable Machine: 65217 and Up)

Action level	Failure code	Failure	System Operating Lamp Short Circuit (Engine Controller) (Engine controller system)
—	CA4952		
Detail of failure	Engine controller determines that system operating lamp circuit shorts because voltage of output circuit does not become Low level while engine controller outputs current to system operating lamp.		
Action of controller	Stops driving system operating lamp.		
Phenomenon on machine	While system operating lamp is lit, battery disconnect switch must not be turned to OFF position. Turning battery disconnect switch to OFF position when the lamp is lit may destroy memory data stored in engine controller, each controller.		
Related information	<ul style="list-style-type: none"> <li>Although engine controller is not able to light up system operating lamp, no trouble will result unless battery disconnect switch is turned to OFF position.</li> <li>When controller lights up system operating lamp, output circuit voltage is at low level.</li> <li>After repairing, check if the failure code is cleared by the following procedure. Procedure: Turn starting switch to ON position.</li> </ul>		

No.	Cause	Procedure, measuring location, criteria and remarks		
1	Defective wiring harness connector	<ol style="list-style-type: none"> <li>See descriptions of wiring harness and connectors in “Electrical equipment” in “CHECKS BEFORE TROUBLESHOOTING” of “RELATED INFORMATION ON TROUBLESHOOTING”, and check it.</li> <li>Turn starting switch to ON position.</li> </ol>		
		If this failure code is cleared, wiring harness connector is defective.		
2	Short circuit in wiring harness	<ol style="list-style-type: none"> <li>Turn the starting switch to OFF position</li> <li>Remove fuse No.4 in fuse box FB4.</li> <li>Disconnect connectors CAN, IDK.</li> <li>Disconnect connectors ECM J2, L80G, MCM1 A, TM41, W1C, and R23, and connect T-adapter to female side of connector R23.</li> </ol>		
		Resistance	Between R23 (female) (1) and (2)	Min. 100 kΩ
3	Hot short circuit in wiring harness	<ol style="list-style-type: none"> <li>Turn the starting switch to OFF position</li> <li>Disconnect connector R23, and connect T-adapter to female side.</li> <li>Turn the starting switch to ON position</li> </ol>		
		Voltage	Between R23 (female) (2) and ground	Max. 1 V
4	Defective DEF purge relay (machine with DEF purge relay)	<ol style="list-style-type: none"> <li>Starting switch: OFF</li> <li>Replace the DEF purge relay.</li> </ol>		
		If this failure code is cleared, the DEF purge relay is defective.		
5	Defective engine controller	If no failure is found by above checks, engine controller is defective. (Since this is an internal defect, troubleshooting cannot be performed.)		

### Circuit Diagram of Key Switch C Terminal Signal

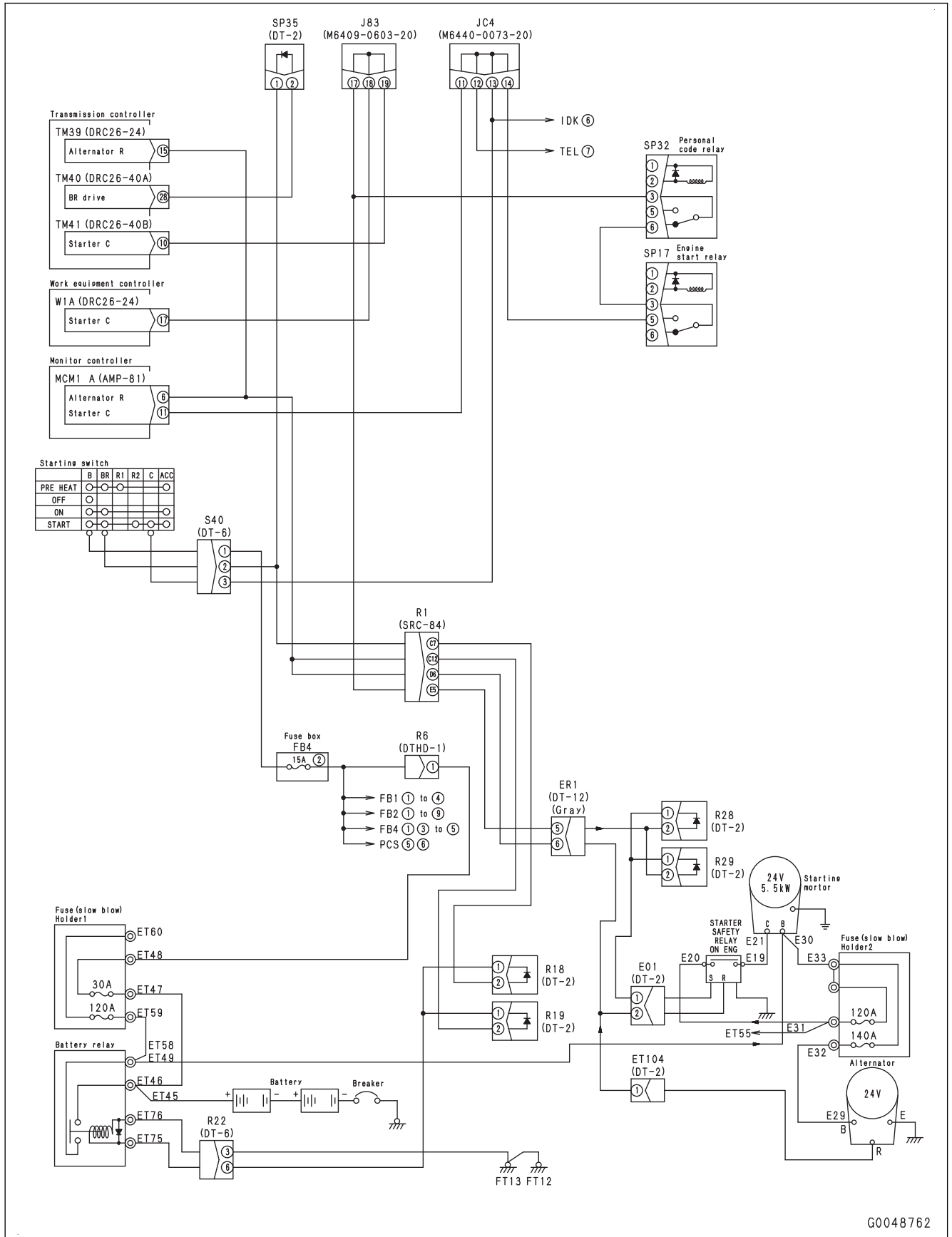

Circuit Diagram of System Operating Lamp

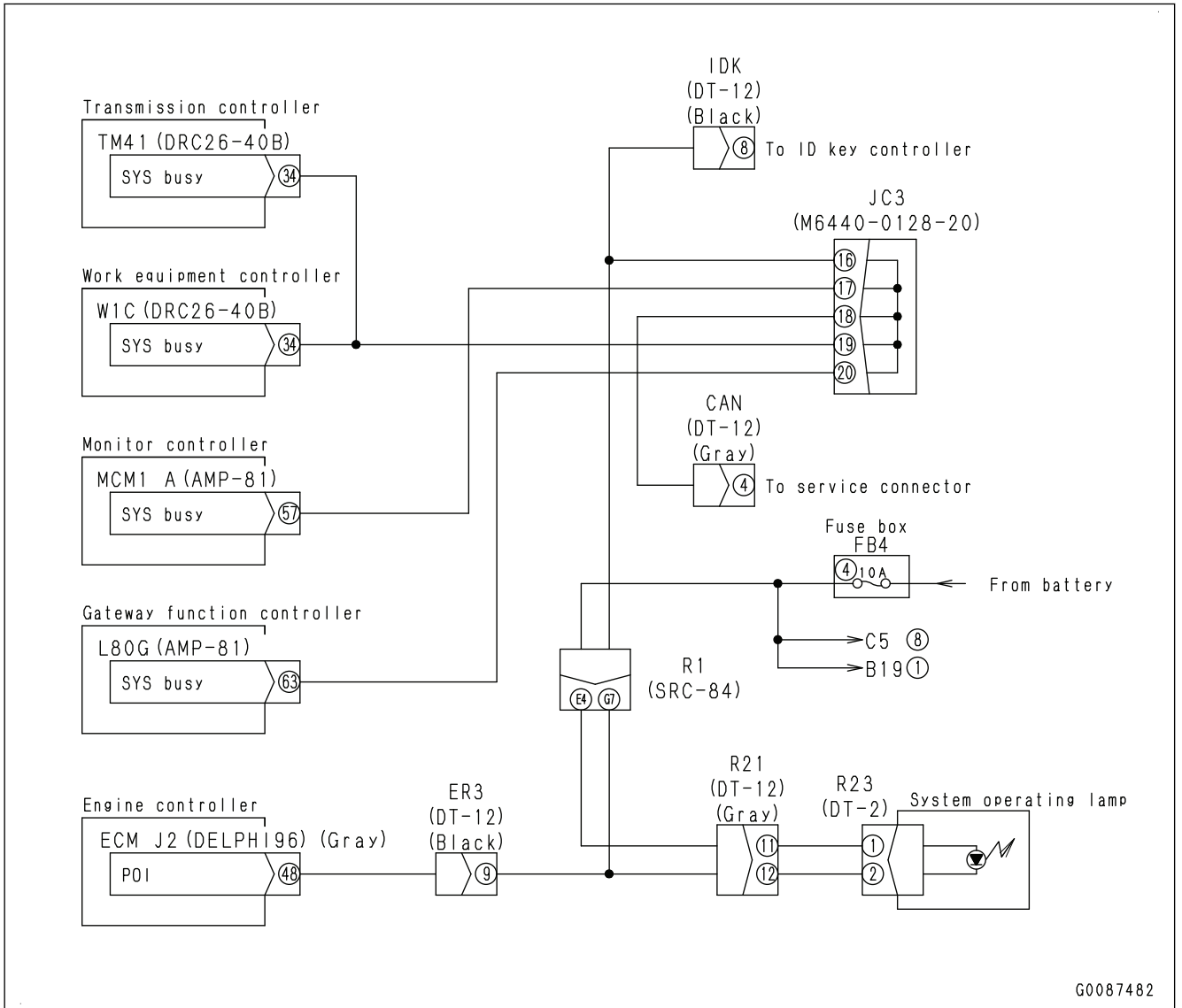

No.	Cause	Procedure, measurement position, standard (value), notes		
6	Defective fuse (ACC signal circuit of transmission controller)	<ol style="list-style-type: none"> <li>1. Starting switch OFF</li> <li>2. Remove fuse No.10 in fuse box FB4.</li> <li>3. Make a visual check for a blown fuse.</li> <li>4. When the fuse is not burnt out, check if it is disconnected by a continuity test.</li> </ol>	<ul style="list-style-type: none"> <li>• When the fuse is blown, troubleshoot the wiring harness for ground fault (ACC signal circuit of transmission controller).</li> <li>• If the fuse is not burnt out but it has no continuity, replace the fuse.</li> </ul>	
7	Defective transmission controller ACC signal circuit	<ol style="list-style-type: none"> <li>1. Starting switch OFF</li> <li>2. Check that the system operating lamp is not lit, and turn the battery disconnect switch to the OFF position.</li> <li>3. Insert the T-adapter to connector TM41.</li> <li>4. Battery disconnect switch ON</li> <li>5. Starting switch ON</li> </ol>	Voltage	Between TM41 (14) and (21) 20 to 30 V
		Between TM41 (24) and (31) 20 to 30 V		
		Between TM41 (14) and (32) 20 to 30 V		
		Between TM41 (14) and (33) 20 to 30 V		
8	Open circuit in wiring harness (ACC signal circuit of transmission controller)	<ol style="list-style-type: none"> <li>1. Starting switch OFF</li> <li>2. Check that the system operating lamp is not lit, and turn the battery disconnect switch to the OFF position.</li> <li>3. Remove fuse No.10 in fuse box FB4.</li> <li>4. Disconnect connector TM41. Connect the T-adapter to the female side.</li> </ol>	Resistance	Between FB4-10 and TM41 (female) (14) Max. 1 Ω
		Between FB4-10 and TM41 (female) (24) Max. 1 Ω		
		Between TM41 (female) (21) and ground Max. 1 Ω		
		Between TM41 (female) (31) and ground Max. 1 Ω		
		Between TM41 (female) (32) and ground Max. 1 Ω		
		Between TM41 (female) (33) and ground Max. 1 Ω		

No.	Cause	Procedure, measuring location, criteria and remarks		
1	Defective potentiometer	1. Starting switch OFF 2. Disconnect the connector of the potentiometer sensors given below one by one. Turn the starting switch to the ON position each time.  <b>REMARK</b> <ul style="list-style-type: none"> <li>• If this failure code turns off, the disconnected sensor is defective.</li> <li>• Because the connector is disconnected, other failure codes are also shown. Ignore all failure codes other than this one.</li> </ul>		
		Connector	Blade shift lever potentiometer sensor	LV8
			Blade lift LEFT lever potentiometer sensor	LV1
			Circle rotation lever potentiometer sensor	LV4
			Ripper/scarifier lever potentiometer sensor	LV9
			Power tilt lever potentiometer sensor	LV7
2	Ground fault in wiring harness	1. Starting switch OFF 2. Disconnect the connectors LV1, LV4, LV7, LV8, LV9, and W1B. 3. Connect the T-adapter to the female side of the connector W1B.		
		Resistance	Between W1B (female) (1) and ground	Min. 1 MΩ
3	Hot short circuit in wiring harness	1. Starting switch OFF 2. Disconnect the connectors LV1, LV4, LV7, LV8, LV9, and W1B. 3. Connect the T-adapter to the female side of the connector W1B. 4. Starting switch ON		
		Voltage	Between W1B (1) and ground	Max. 1 V
4	Defective work equipment controller	If no failure is found by the previous checks, the work equipment controller is defective.		
		<ul style="list-style-type: none"> <li>• Reference</li> </ul> 1. Starting switch OFF 2. Disconnect the connector W1B. Connect the T-adapter to the male side. 3. Starting switch ON		
		Voltage	Between W1B (male) (1) and ground	4.8 to 5.2 V

### Circuit Diagram of Parking Brake (Applicable Machine: 65001 to 65481)

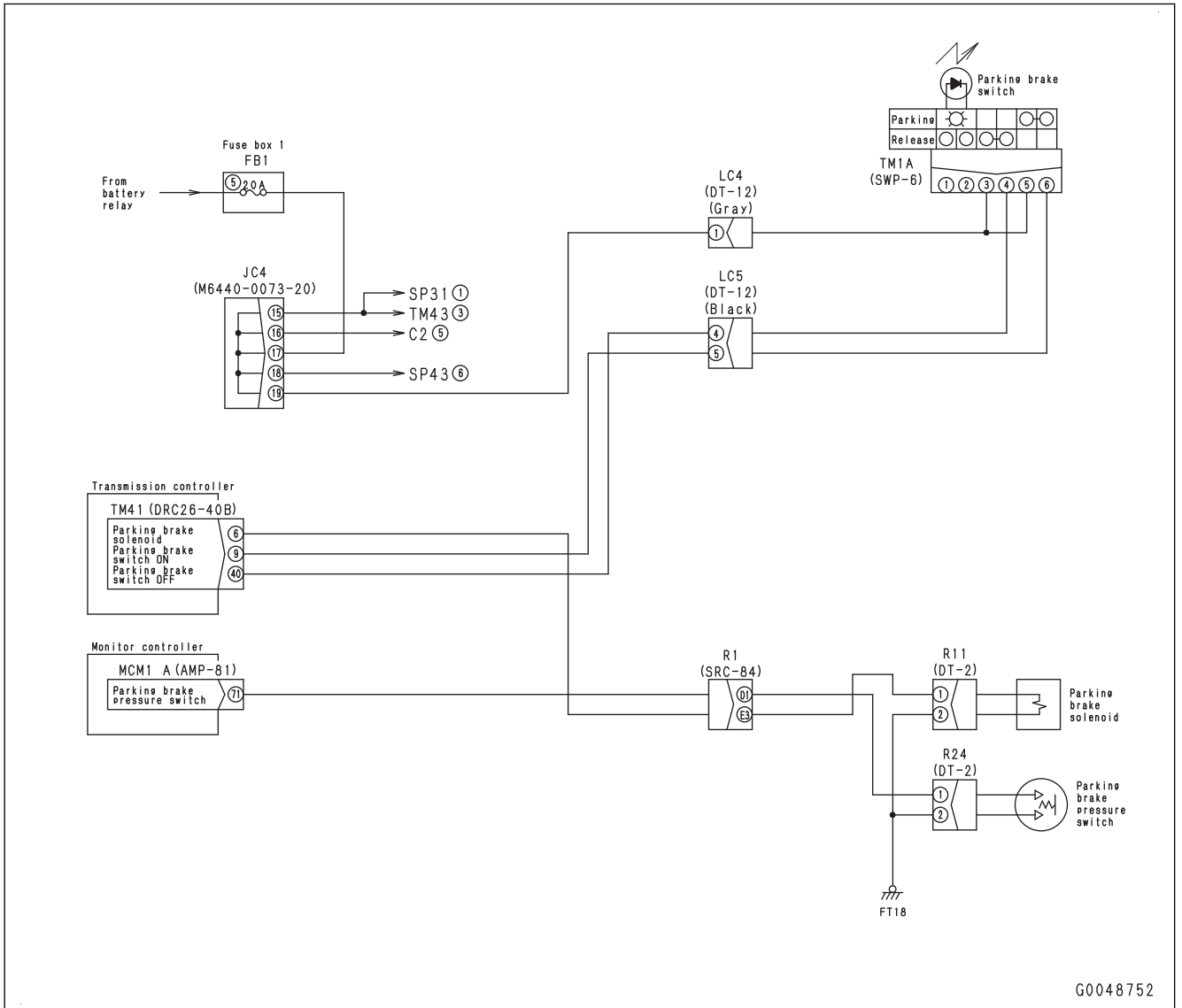

**Failure Code [DDLBL4]**

Action level	Failure code	Failure	Cross Slope Activation Switch Combination Error (Work equipment controller system)
L01	DDLBL4		
Detail of failure	The ON signal and OFF signal of cross slope activation switch are turned on at the same time.		
Action of controller	<ul style="list-style-type: none"> <li>Ends the cross slope control.</li> <li>Even if the cause of the failure no longer exists, the machine does not become normal until the starting switch is turned to the OFF position one time.</li> </ul>		
Phenomenon on machine	<ul style="list-style-type: none"> <li>Even if the cross slope activation switch is operated, the monitor display does not change from the standard screen to the cross slope screen.</li> <li>Even if the cross slope activation switch is operated, the monitor display does not change from the cross slope screen to the standard screen.</li> <li>The cross slope control ends.</li> <li>The monitor display changes from the cross slope screen to the standard screen.</li> </ul>		
Related information	<ul style="list-style-type: none"> <li>The input state of ON signal and OFF signal of Cross Slope activation switch can be checked with monitoring function. (Code: 41125)</li> <li>The operation of the work equipment by the work equipment control lever can be done.</li> <li>After the repair is done, check that the failure code is not shown with the operation that follows.</li> </ul> <p>Procedure: Start the engine.</p>		

No.	Cause	Procedure, measurement location, criteria and remarks		
1	Defective wiring harness connector	<ol style="list-style-type: none"> <li>Examine the wiring harness and connector. For details, see “Related Information for Troubleshooting”, “Checks Before Troubleshooting”, “Electrical components”.</li> <li>Start the engine.</li> </ol>		
		If this failure code is cleared, the wiring harness connector is defective.		
2	Ground fault in wiring harness	<ol style="list-style-type: none"> <li>Starting switch: OFF</li> <li>Disconnect the connectors CS6 and W1B. Connect the T-adapter to one of them on the female side.</li> </ol>		
		Resistance	Between ground and one of CS6 (female) (4) and W1B (female) (27)	Min. 1MΩ
			Between ground and one of CS6 (female) (6) and W1B (female) (37)	Min. 1MΩ
3	Short circuit in wiring harness	<ol style="list-style-type: none"> <li>Starting switch: OFF</li> <li>Disconnect the connectors CS6 and W1B. Connect the T-adapter to the female side of W1B.</li> </ol>		
		Resistance	Between W1B (female) (27) and each pin other than pin (27)	Min. 1MΩ
			Between W1B (female) (37) and each pin other than pin (37)	Min. 1MΩ

## Failure Code [DFA9KY]

Action level	Failure code	Failure	Power Tilt Lever Potentiometer Hot Short Circuit (Sub) (Work equipment controller system)
L03	DFA9KY		
Details of failure	Because of a hot short circuit in the potentiometer (sub: B line) system of the power tilt lever, the signal voltage of the potentiometer (sub: B line) of the power tilt lever is higher than the normal range. (The signal voltage of the potentiometer (sub: B line) of the power tilt lever: 4.7 V or more)		
Action of controller	<ul style="list-style-type: none"> <li>If the potentiometer (main: A line) of the power tilt control lever is normal, the controller controls with the potentiometer (main: A line) of the power tilt control lever. But it reduces the work equipment speed to 30 %.</li> <li>Makes the centralized warning lamp light up and the alarm buzzer operate.</li> <li>Even if the cause of the failure no longer exists, the machine does not become normal until the power tilt control lever is set to NEUTRAL.</li> <li>After the parking brake is applied and the work equipment lock is engaged, the controller enters the function limitation state.(Applicable Machine: 65482 and up)</li> </ul>		
Phenomenon on machine	<ul style="list-style-type: none"> <li>The power tilt control does not operate.</li> <li>The work equipment speed decreases to 30 % of normal speed.</li> <li>In the function limitation state, only one of the parking brake and the work equipment lock can be released.(Applicable Machine: 65482 and up)</li> </ul>		
Related information	<ul style="list-style-type: none"> <li>The input voltage from the power tilt lever potentiometer (main: A line) can be read with the monitoring function. (Code: 58200)</li> <li>The input voltage from the power tilt lever potentiometer (sub: B line) can be read with the monitoring function. (Code: 58201)</li> <li>After the repair is completed, make sure with operation explained below that the failure code is not shown. Procedure: Starting switch ON</li> <li>In the function limitation state, the functions are limited to secure machine safety, but the machine can be moved to a safe zone.(Applicable Machine: 65482 and up)</li> <li>When in the function limitation state, move the machine to a safe zone and repair the failure part.(Applicable Machine: 65482 and up)</li> </ul>		

No.	Cause	Procedure, measuring location, criteria and remarks					
1	Defective 5V sensor power supply system	If failure code [DB96KX] is also shown at the same time, do the troubleshooting for failure code [DB96KX] first. If failure code [DB96KX] is not shown at the same time, do the troubleshooting below.					
		<ol style="list-style-type: none"> <li>Starting switch OFF</li> <li>Disconnect the connector LV7. Connect the T-adaptor to the female side.</li> <li>Starting switch ON</li> </ol>					
		<p><b>REMARK</b></p> <p>If the power supply voltage is abnormal, go to the cause 2 and after.</p> <table border="1"> <tr> <td>Voltage</td> <td>Between LV7 (female) (1) and (2)</td> <td>4.8 to 5.2V</td> </tr> </table>			Voltage	Between LV7 (female) (1) and (2)	4.8 to 5.2V
Voltage	Between LV7 (female) (1) and (2)	4.8 to 5.2V					
2	Hot short circuit in wiring harness	<ol style="list-style-type: none"> <li>Starting switch OFF</li> <li>Disconnect the connector LV7. Connect the T-adaptor to the female side.</li> <li>Starting switch ON</li> </ol>					
		<table border="1"> <tr> <td>Voltage</td> <td>Between LV7 (female) (4) and (2)</td> <td>Max. 1 V</td> </tr> </table>			Voltage	Between LV7 (female) (4) and (2)	Max. 1 V
		Voltage	Between LV7 (female) (4) and (2)	Max. 1 V			

**Failure Code [DFAMKA]**

Action level	Failure code	Failure	Open Circuit or Ground Fault of Circle Rotation Lever Potentiometer (Sub) (Work equipment controller system)
L03	DFAMKA		
Details of failure	Because of an open circuit or ground fault in the circle rotation lever potentiometer (sub: B line) system, the circle rotation lever potentiometer (sub: B line) signal voltage is lower than the normal range. (Circle rotation lever potentiometer (sub: B line) signal voltage: 0.3 V and below)		
Action of controller	<ul style="list-style-type: none"> <li>When the circle rotation lever potentiometer (main: A line) is normal, the circle rotation lever potentiometer (main: A line) is used for control. But it reduces the work equipment speed to 30 %.</li> <li>Makes the centralized warning lamp light up and the alarm buzzer operate.</li> <li>Even if the cause of the failure no longer exists, the machine does not become normal until the blade rotation control lever is set to NEUTRAL.</li> <li>After the parking brake is applied and the work equipment lock is engaged, the controller enters the function limitation state.(Applicable Machine: 65482 and up)</li> </ul>		
Phenomenon on machine	<ul style="list-style-type: none"> <li>Blade rotation control does not operate.</li> <li>The work equipment speed decreases to 30 % of normal speed.</li> <li>In the function limitation state, only one of the parking brake and the work equipment lock can be released.(Applicable Machine: 65482 and up)</li> </ul>		
Related information	<ul style="list-style-type: none"> <li>The input voltage from the circle rotation lever potentiometer (main: A line) can be read with the monitoring function. (Code: 57900)</li> <li>The input voltage from the circle rotation lever potentiometer (sub: B line) can be read with the monitoring function. (Code: 57901)</li> <li>After the repair is completed, make sure with the operation explained below that the failure code is not shown. Procedure: Starting switch ON</li> <li>In the function limitation state, the functions are limited to secure machine safety, but the machine can be moved to a safe zone.(Applicable Machine: 65482 and up)</li> <li>When in the function limitation state, move the machine to a safe zone and repair the failure part.(Applicable Machine: 65482 and up)</li> </ul>		

No.	Cause	Procedure, measuring location, criteria and remarks	
1	Defective 5V sensor power supply system	If failure code [DB96KX] is also shown at the same time, do the troubleshooting for failure code [DB96KX] first. If failure code [DB96KX] is not shown at the same time, do the troubleshooting below.	
		1. Starting switch OFF 2. Disconnect the connector LV4. Connect the T-adaptor to the female side. 3. Starting switch ON  <b>REMARK</b> If the power supply voltage is abnormal, go to the cause 2 and after.	
		Voltage	Between LV4 (female) (1) and (2) 4.8 to 5.2V

No.	Cause	Procedure, measuring location, criteria and remarks			
5	Defective blade lift LEFT lever potentiometer	1. Starting switch OFF 2. Insert the T-adapter into the connector LV1. 3. Push the work equipment lock switch to lock the work equipment (work equipment lock pilot lamp lights up) 4. Starting switch ON 5. Operate the L.H. blade lift control lever to troubleshoot			
		Voltage	Between LV1 (3) and (2)	L.H. blade lift control lever: NEUTRAL	2.37 to 2.63V
				L.H. blade lift control lever: LOWER operation (Full stroke)	3.82 to 4.48V
				L.H. blade lift control lever: RAISE operation (Full stroke)	0.52 to 1.18V
		Between LV1 (4) and (2)	L.H. blade lift control lever: NEUTRAL	2.37 to 2.63V	
			L.H. blade lift control lever: LOWER operation (Full stroke)	0.52 to 1.18V	
			L.H. blade lift control lever: RAISE operation (Full stroke)	3.82 to 4.48V	

No.	Cause	Procedure, measurement position, standard (value), notes
4	Open circuit (wire breakage or defective contact of connector) in wiring harness	If no failure is found by checks of the wiring harness for open and short circuit, this check is not required. 1. Starting switch OFF 2. Check that the system operating lamp is not lit. Turn the battery disconnect switch to the OFF position. 3. Disconnect connector TM39 and T34. Connect the T-adapter to each female side.
		Resistance
5	Ground fault in wiring harness (contact with ground circuit)	If no failure is found by checks of wiring harness for short circuits, ground faults or hot short circuits, this check is not required. 1. Starting switch OFF 2. Check that the system operating lamp is not lit. Turn the battery disconnect switch to the OFF position. 3. Disconnect connectors TM39 and T34. Connect the T-adapter to one of the female sides.
		Resistance
6	Defective transmission controller	If no failure is found by the previous checks, the transmission controller is defective. (Since this is an internal defect, troubleshooting cannot be done.)

**Circuit Diagram of Torque Converter Oil Temperature Sensor**

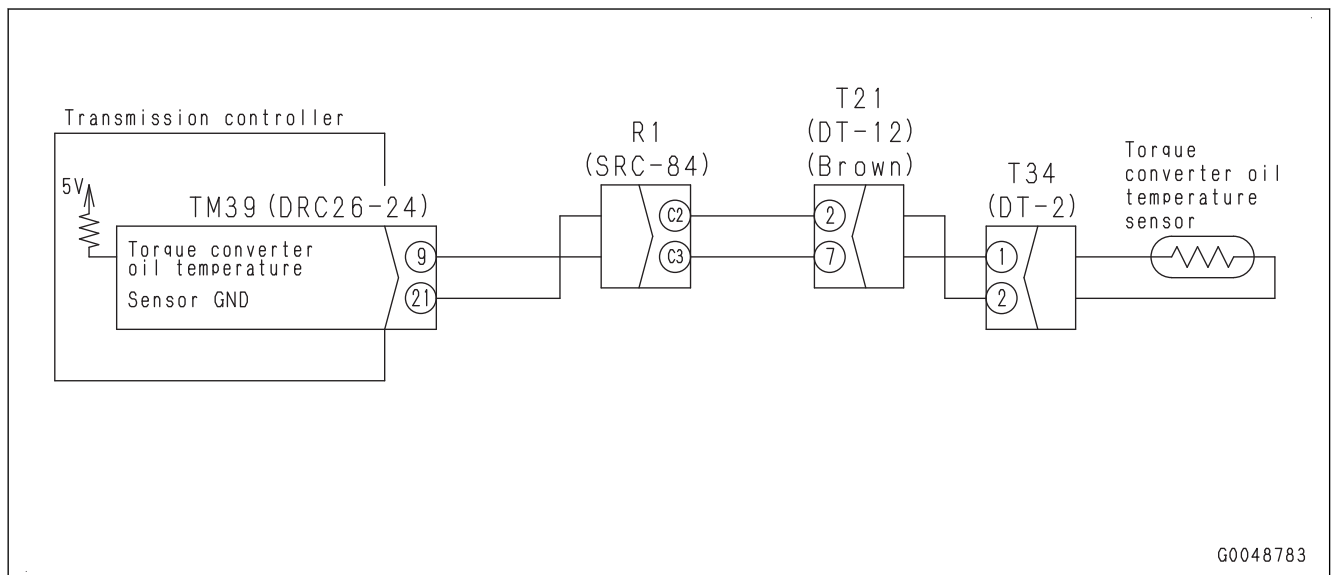

**Failure Code [DLM3KA]**

Action Level	Failure code	Failure	Radiator Fan Speed Sensor Open Circuit or Hot Short Circuit (transmission controller system)
L01	DLM3KA		
Detail of failure	<ul style="list-style-type: none"> <li>Pulse voltage is not entered from the fan speed sensor due to open circuit in fan shaft sensor.</li> <li>This failure code is displayed when the following conditions are satisfied.                             <ol style="list-style-type: none"> <li>Input voltage 3 to 4</li> <li>Without actual pulse input</li> </ol> </li> </ul>		
Action of the controller	<ul style="list-style-type: none"> <li>Even if the cause of the failure no longer exists, the machine does not become normal until the starting switch is turned to the OFF position.</li> <li>Cancels radiator fan feedback control.</li> </ul>		
Phenomenon on machine	Target speed is not reached, so fuel consumption may increase or engine may overheat.		
Related information	<ul style="list-style-type: none"> <li>The radiator fan speed can be read with the monitoring function. (Code: 10009)</li> <li>After the repair is completed, check with operation explained below that the failure code is not shown.</li> </ul> Procedure: Start the engine		

No.	Cause	Procedure, measurement position, standard (value), notes		
1	Defective radiator fan speed sensor	1. Starting switch OFF 2. Disconnect connector RT8. Connect the T-adapter to the male side.		
		Resistance	Between RT8 (male) (1) and (2)	2 to 3 kΩ
			Between RT8 (male) (1) and ground	Min. 1 MΩ
2	Open circuit, short circuit, ground fault, hot short circuit in wiring harness, or defective transmission controller	1. Starting switch OFF 2. Disconnect connector RT8. Connect the T-adapter to the female side. 3. Starting switch ON <b>REMARK</b> Shake the wiring harness by hand while measuring the voltage. If the voltage becomes 0 V while shaking, an open circuit exists in the wiring harness at around this point.		
		Voltage	Between RT8 (female) (1) and (2)	1 to 4.5 V
3	Open or short circuit in wiring harness	1. Starting switch OFF 2. Check that the system operating lamp is not lit. Turn the battery disconnect switch to the OFF position. 3. Disconnect connector TM40. Connect the T-adapter to the female side.		
		Resistance	Between TM40 (female) (10) and (39)	2 to 3 kΩ
4	Open circuit in wiring harness (wire breakage, defective contact)	1. Starting switch OFF 2. Check that the system operating lamp is not lit. Turn the battery disconnect switch to the OFF position. 3. Disconnect connector TM40 and RT8. Connect the T-adapter to each female side.		
		Resistance	Between TM40 (female) (10) and RT8 (female) (1)	Max. 1 Ω
			Between TM40 (female) (39) and RT8 (female) (2)	Max. 1 Ω

### Circuit Diagram of Power Tilt TILT EPC Solenoid

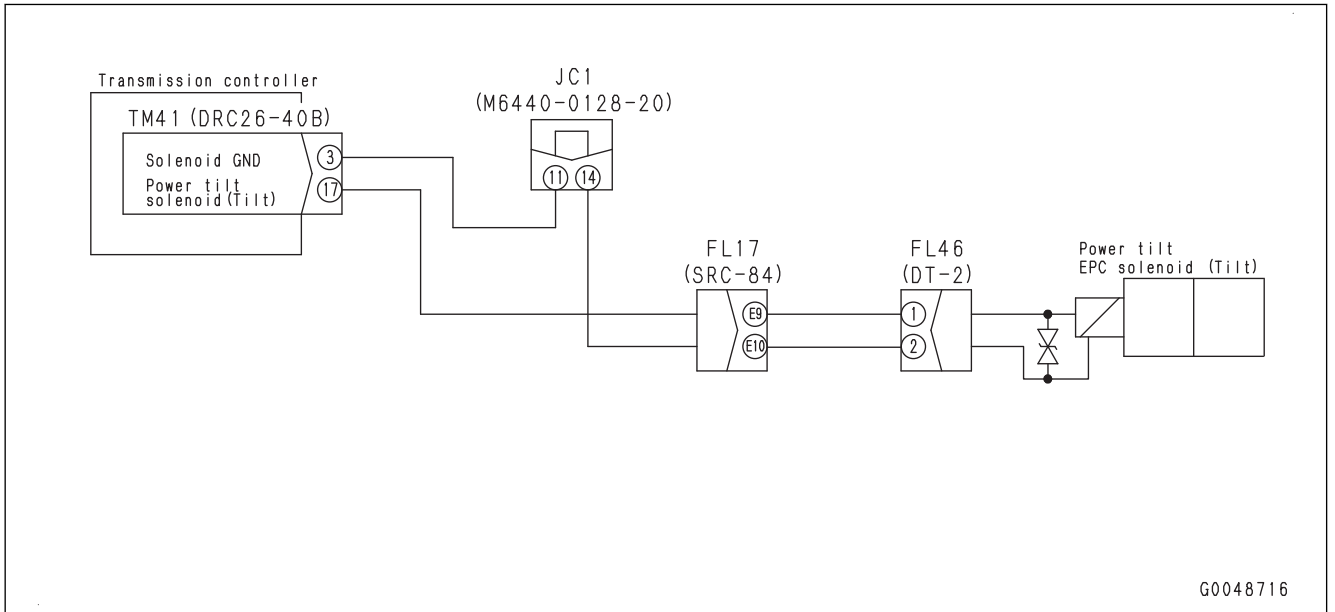

CLICK HERE TO **DOWNLOAD** THE COMPLETE MANUAL

- Thank you very much for reading the preview of the manual.
- You can download the complete manual from: [www.heydownloads.com](http://www.heydownloads.com) by clicking the link below



- Please note: If there is no response to CLICKING the link, please download this PDF first and then click on it.

CLICK HERE TO **DOWNLOAD** THE COMPLETE MANUAL

**Failure Code [DWP5KB]**

Action level	Failure code	Failure	EPC Solenoid Ground Fault (Ripper/Scarifier LOWER) (Work equipment controller system)
L03	DWP5KB		
Detail of failure	When the controller energizes the ripper/scarifier LOWER EPC solenoid, an abnormal current flows through the circuit.		
Action of controller	<ul style="list-style-type: none"> <li>Keeps the output to the ripper/scarifier LOWER EPC solenoid off.</li> <li>Even if the cause of the failure no longer exists, the machine does not become normal until the starting switch is turned to the OFF position one time.</li> </ul>		
Phenomenon on machine	<ul style="list-style-type: none"> <li>Ripper/scarifier LOWER control is disabled.</li> <li>The wiring harness or the controller is probably burnt out.</li> </ul>		
Related information	<ul style="list-style-type: none"> <li>You can check the output current command value to the ripper/scarifier LOWER EPC solenoid with the monitoring function. (Code: 59201)</li> <li>After the repair is completed, do the operation explained below to make sure that the failure code is not shown. Procedure: Starting switch ON</li> </ul>		

No.	Cause	Procedure, measuring location, criteria, and remarks		
1	Defective ripper/scarifier LOWER EPC solenoid	1. Starting switch OFF		
		2. Disconnect the connector FL30. Connect the T-adapter to the male side.		
		Resistance	Between FL30 (male) (1) and (2)	6 to 8Ω
			Between FL30 (male) (1) and ground	Min. 1 MΩ
2	Ground fault in wiring harness	1. Starting switch OFF		
		2. Make sure that the system operating lamp is not lit. Turn the battery disconnect switch to the OFF position.		
		3. Disconnect the connectors W1C and FL30. Connect the T-adapter to the female side of one of them.		
		Resistance	Between ground and one of W1C (female) (6) or FL30 (female) (1)	Min. 1 MΩ
3	Short circuit in wiring harness	1. Starting switch OFF		
		2. Make sure that the system operating lamp is not lit. Turn the battery disconnect switch to the OFF position.		
		3. Disconnect the connectors W1C and FL30. Connect the T-adapter to the female side of W1C.		
		Resistance	Between W1C (female) (6) and each pin other than pin (6)	Min. 1 MΩ
4	Defective work equipment controller	If no failure is found by the previous checks, the work equipment controller is defective. (Since this is an internal defect, troubleshooting cannot be done.)		

No.	Cause	Procedure, measurement position, standard (value), notes		
2	Short circuit in wiring harness	1. Starting switch OFF 2. Check that the system operating lamp is not lit. Turn the battery disconnect switch to the OFF position. 3. Disconnect connectors TM41 and T24. Connect the T-adapter to the female side of TM41.		
		Continuity	Between TM41 (female) (26) and each pin other than (26)	No continuity
		Since there is no T-adapter for connector R1, check for short circuit at R1 as follows. 1. Starting switch OFF 2. Check that the system operating lamp is not lit. Turn the battery disconnect switch to the OFF position. 3. Disconnect connectors TM39, TM40, TM41, and T24. Connect the T-adapter to the female side of TM39, TM40 and TM41.		
		<b>REMARK</b> Connectors TM39, TM40 and TM41 are connectors for the transmission controller. Each of them have a R1 connector as an intermediate connector.		
		Continuity	Between TM41 (female) (26) and each pin of TM39 (female)	No continuity
			Between TM41 (female) (26) and each pin of TM40 (female)	No continuity
3	Defective transmission controller	If no failure is found by the previous checks, the transmission controller is defective. (Since this is an internal defect, troubleshooting cannot be done.)		

**Circuit Diagram of FL Clutch**

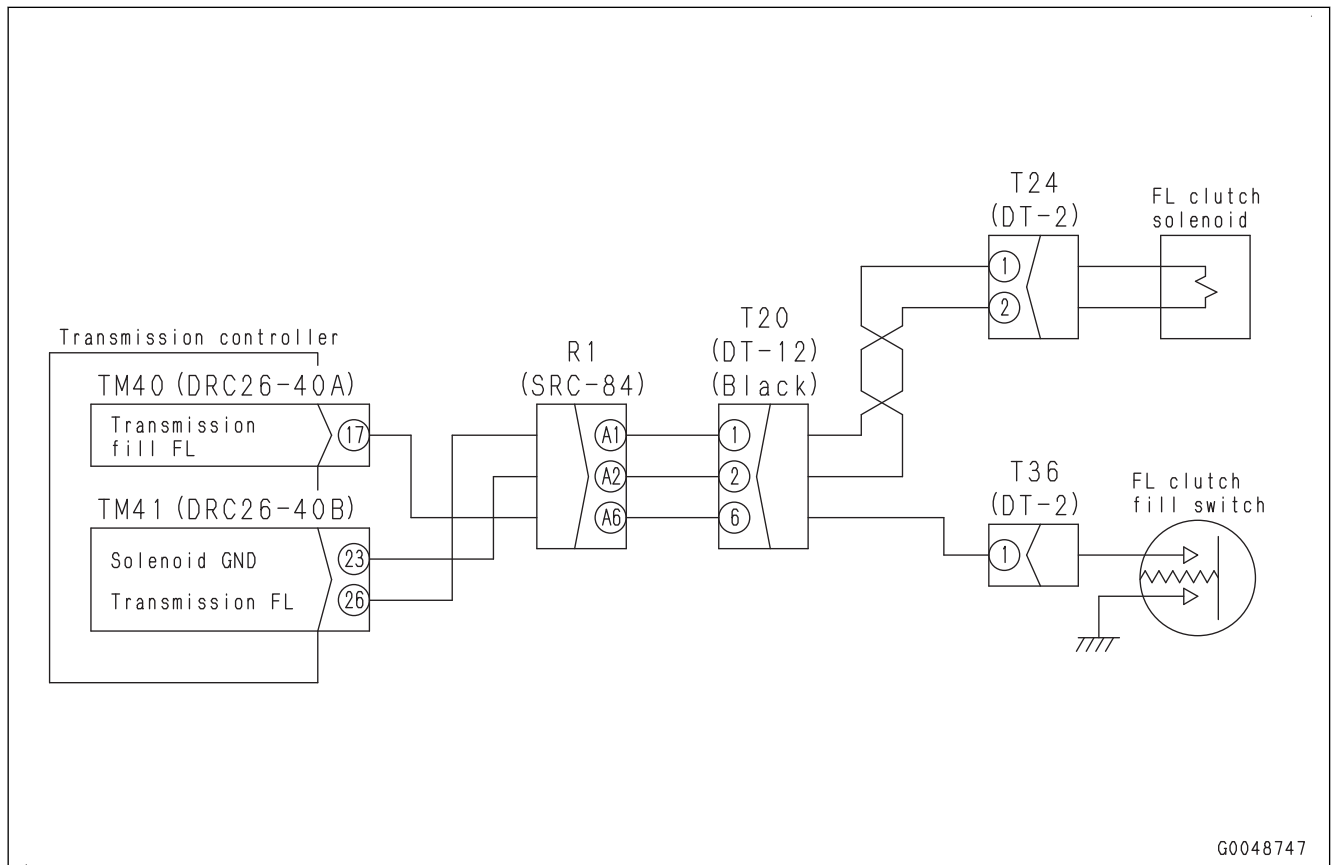

Number of gear shift when failure is found		Abnormal clutch	Remedy when failure is found		
			Action of controller (Selected clutch, gear speed)		State of lockup clutch
R2	2nd Re-verse	4th	4th Reverse	R4(*1)	OFF
		3rd	3rd Reverse	R3	OFF
		1st	OFF	NEUTRAL	OFF
		FH	OFF	NEUTRAL	OFF
		FL	OFF	NEUTRAL	OFF
R1	1st Re-verse	4th	4th Reverse	R4(*1)	OFF
		3rd	3rd Reverse	R3	OFF
		2nd	2nd Reverse	R2	OFF
		FH	OFF	NEUTRAL	OFF
		FL	OFF	NEUTRAL	OFF

### Circuit Diagram of the Leaning Left EPC Solenoid

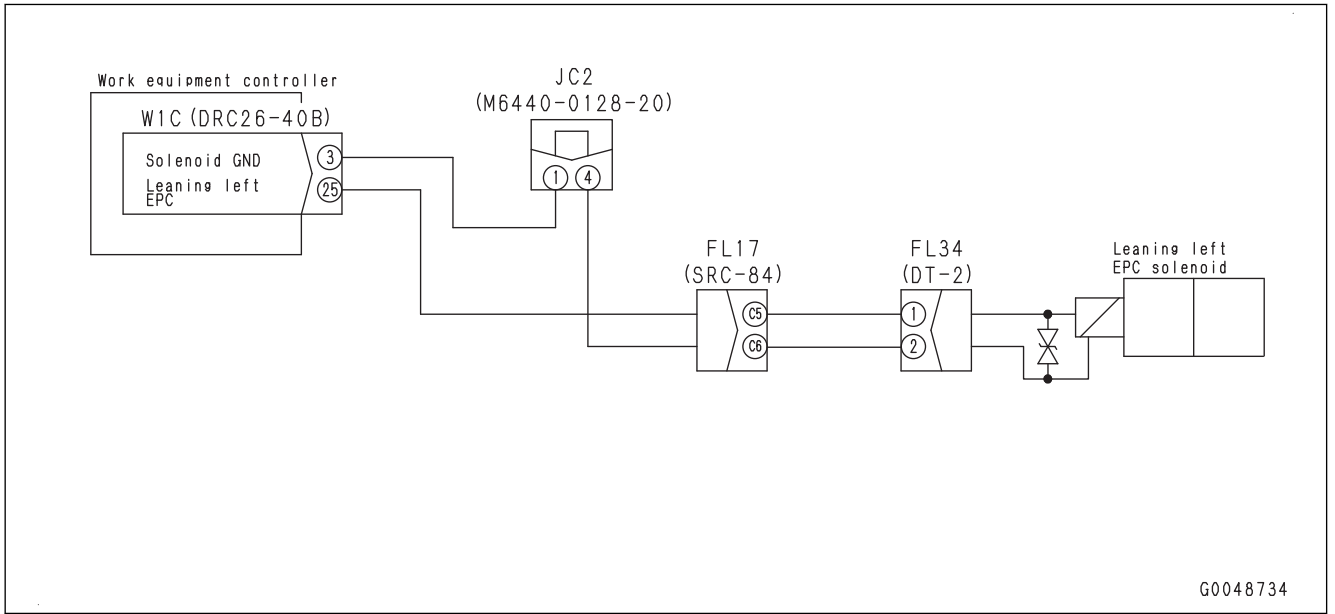

No.	Check item	Procedure of troubleshooting	Judgment and remedy	
4	Confirmation of repair	1. Turn the starting switch to the OFF position. 2. Connect all the component parts. 3. Turn the starting switch to the ON position. Then, do the troubleshooting. 4. Is this failure code shown?	YES	Go back to the first check item.
			NO	The repair is done.

### Circuit Diagram of Gateway Function Controller

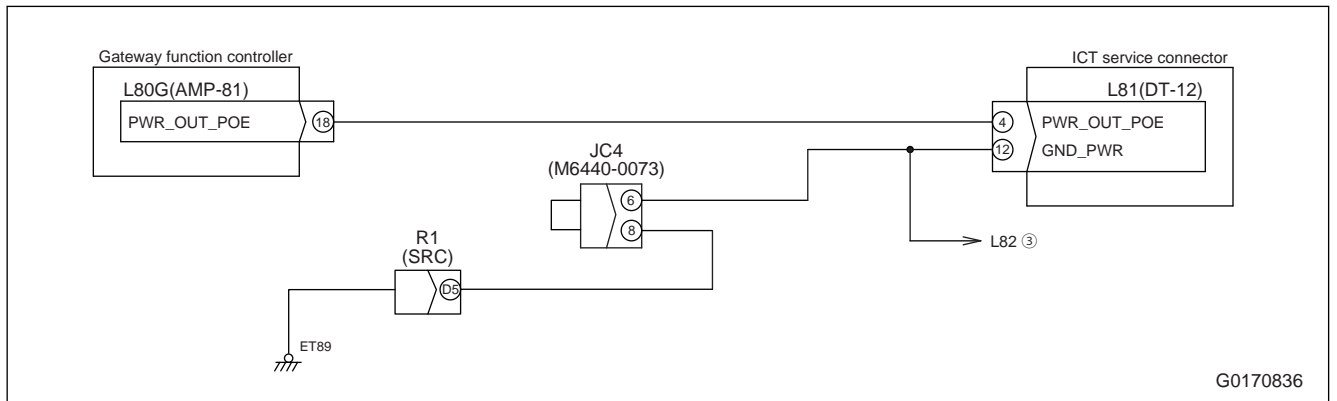

## Failure Code [#Q0014]

Action level	Failure code	Failure	Abnormality of SASAID sensor 4 (S/T) (Transmission controller system)
L03	#Q0014		
Details of failure	The data of the sensor is out of range.		
Action of controller	<ul style="list-style-type: none"> <li>Lights up the centralized warning lamp and makes the alarm buzzer sound.</li> <li>Even if the cause of the failure no longer exists, the machine does not go back to normal until the steering control lever enable switch is turned to the OFF position and then to the ON position.</li> </ul>		
Phenomenon on machine	It becomes not possible to steer with the steering control lever.		
Related information	<ul style="list-style-type: none"> <li>It is possible to steer with the steering wheel.</li> <li>The transmission controller energizes the power supply relay for the steering control lever to supply power to the components related to the steering control lever only when the starting switch is in the ON position and the operator is in the seat.</li> </ul>		

No.	Cause	Procedure, measuring location, criteria and remarks		
1	Open circuit in wiring harness (power supply line)	<ol style="list-style-type: none"> <li>Starting switch OFF</li> <li>Remove the fuse No. 14 in fuse box FB1.</li> <li>Disconnect the connectors SAS, LST4. Connect the T-adapter to each female side.</li> </ol>		
		Resistance	Between LST4 (female) (3) and SAS (female) (3)	Max. 1 Ω
			Between SAS (female) (4) and LST4 (female) (6)	Max. 1 Ω
2	Ground fault in wiring harness (power supply line)	<ol style="list-style-type: none"> <li>Starting switch OFF</li> <li>Remove the fuse No. 14 in fuse box FB1.</li> <li>Disconnect the connectors C36, LST1, LST4, LST5, LST6, SAS, SL1, TM39, TM40.</li> <li>Connect the T-adapter to the female side of connectors C36, LST4, SAS.</li> </ol>		
		Resistance	Between ground and FB1-14 or C36 (female) (3)	Min. 1 MΩ
			Between ground and C36 (female) (5) or LST4 (female) (2)	Min. 1 MΩ
			Between ground and LST4 (female) (3) or SAS (female) (3)	Min. 1 MΩ
3	Hot short circuit in wiring harness (power supply line)	<ol style="list-style-type: none"> <li>Starting switch OFF</li> <li>Remove the fuse No. 14 in fuse box FB1.</li> <li>Disconnect the connectors C36, LST1, LST4, LST5, LST6, SAS, SL1, TM39, TM40.</li> <li>Connect the T-adapter to the female side of connectors C36, LST4, SAS.</li> <li>Starting switch ON</li> </ol>		
		Voltage	Between ground and FB1-14 or C36 (female) (3)	Max. 1 V
			Between ground and C36 (female) (5) or LST4 (female) (2)	Max. 1 V
			Between ground and LST4 (female) (3) or SAS (female) (3)	Max. 1 V

No.	Cause	Procedure, measuring location, criteria and remarks		
4	Hot short circuit in wiring harness (power supply line)	<ol style="list-style-type: none"> <li>1. Starting switch OFF</li> <li>2. Remove the fuse No. 14 in fuse box FB1.</li> <li>3. Disconnect the connectors C36, LST1, LST4, LST5, LST6, SAS, SL1, TM39, TM40.</li> <li>4. Connect the T-adapter to the female side of connectors C36, LST4 and SL1.</li> <li>5. Starting switch ON</li> </ol>		
		Voltage	Between ground and FB1-14 or C36 (female) (3)	Max. 1 V
			Between ground and C36 (female) (5) or LST4 (female) (2)	Max. 1 V
			Between ground and LST4 (female) (3), SL1 (female) (2) or (3)	Max. 1 V
5	Open circuit in wiring harness (CAN communication line)	<ol style="list-style-type: none"> <li>1. Starting switch OFF</li> <li>2. Disconnect the connectors SL1 and LST1. Connect the T-adapter to each female side.</li> </ol>		
		Resistance	Between SL1 (female) (6) and LST1 (female) (4)	Max. 1 Ω
			Between SL1 (female) (6) and LST1 (female) (10)	Max. 1 Ω
			Between SL1 (female) (5) and LST1 (female) (5)	Max. 1 Ω
Between SL1 (female) (5) and LST1 (female) (9)	Max. 1 Ω			
6	Ground fault in wiring harness (CAN communication line)	<ol style="list-style-type: none"> <li>1. Starting switch: OFF</li> <li>2. Disconnect the connectors LST1, LST3, LST6, SAS, SL1, TM40, T10A, T10B.</li> <li>3. Connect the T-adapter to the female side of connector SL1.</li> </ol>		
		Resistance	Between SL1 (female) (6) and ground	Min. 1 MΩ
			Between SL1 (female) (5) and ground	Min. 1 MΩ
7	Hot short circuit in wiring harness (CAN communication line)	<ol style="list-style-type: none"> <li>1. Starting switch: OFF</li> <li>2. Disconnect the connectors LST1, LST3, LST6, SAS, SL1, TM40, T10A, T10B.</li> <li>3. Connect the T-adapter to the female side of connector SL1.</li> <li>4. Starting switch ON</li> </ol>		
		Voltage	Between SL1 (female) (6) and ground	Max. 1 V
			Between SL1 (female) (5) and ground	Max. 1 V

### Circuit Diagram of the Steering Control Lever

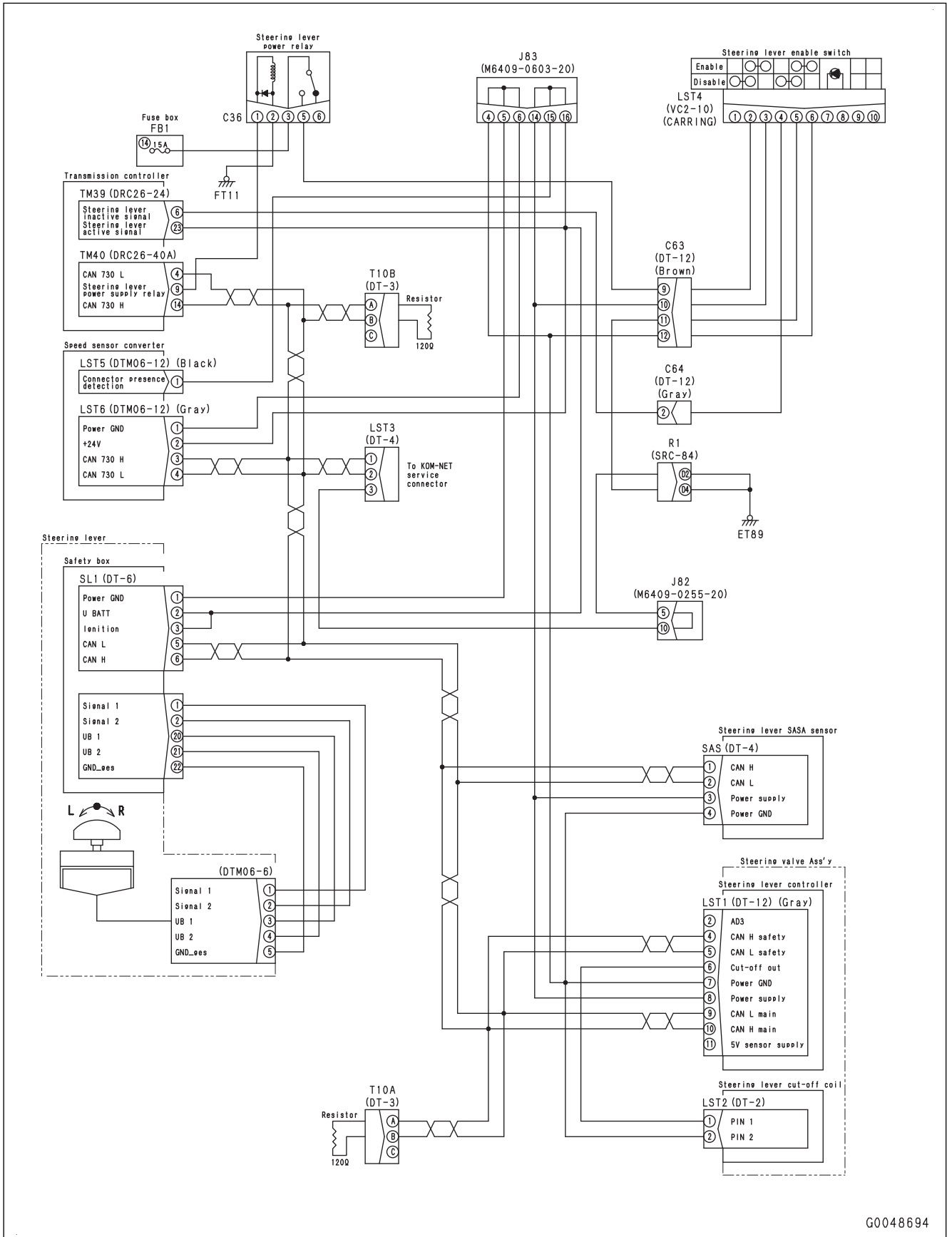

G0048694

No.	Cause	Procedure, measuring location, criteria and remarks		
4	Ground fault in wiring harness (power supply line)	1. Starting switch OFF 2. Remove the fuse No. 14 in fuse box FB1. 3. Disconnect the connectors C36, LST1, LST4, LST5, LST6, SAS, SL1, TM39, TM40. 4. Connect the T-adapter to the female side of connectors C36, LST1 and LST4.		
		Resistance	Between ground and FB1-14 or C36 (female) (3)	Min. 1 MΩ
			Between ground and C36 (female) (5) or LST4 (female) (2)	Min. 1 MΩ
			Between ground and LST4 (female) (3) or LST1 (female) (8)	Min. 1 MΩ
5	Hot short circuit in wiring harness (power supply line)	1. Starting switch OFF 2. Remove the fuse No. 14 in fuse box FB1. 3. Disconnect the connectors C36, LST1, LST4, LST5, LST6, SAS, SL1, TM39, TM40. 4. Connect the T-adapter to the female side of connectors C36, LST1 and LST4. 5. Starting switch ON		
			Between ground and FB1-14 or C36 (female) (3)	Max. 1 V
		Voltage	Between ground and C36 (female) (5) or LST4 (female) (2)	Max. 1 V
			Between ground and LST4 (female) (3) or LST1 (female) (8)	Max. 1 V
6	Defective steering valve assembly	Replace the steering valve assembly.		

### Circuit Diagram of the Steering Control Lever

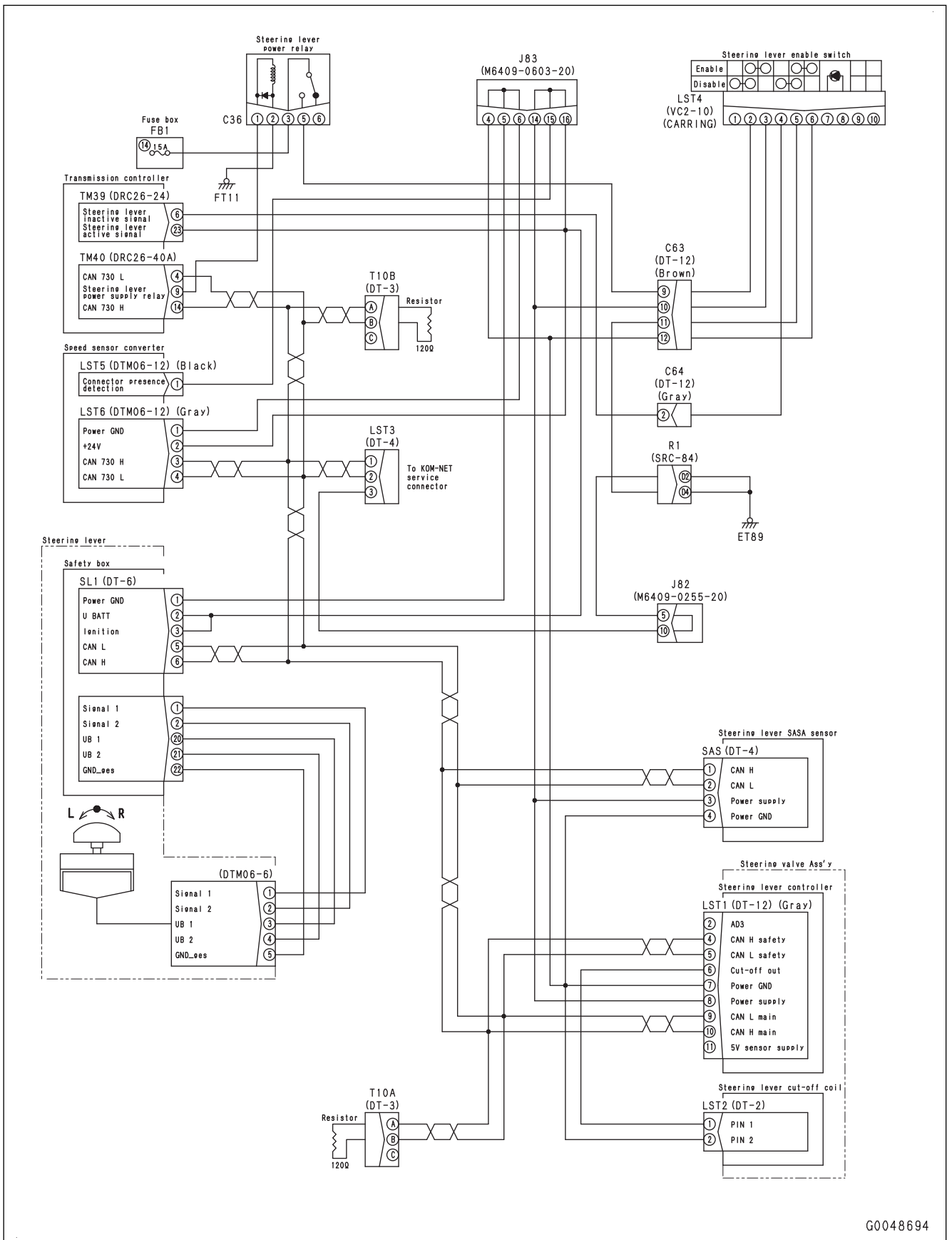

G0048694

No.	Cause	Procedure, measuring location, criteria and remarks		
4	Open circuit in wiring harness (power supply line)	1. Starting switch OFF 2. Remove the fuse No. 14 in fuse box FB1. 3. Disconnect the connectors LST1, LST4 and C36. Connect the T-adapter to each female side.		
		Resistance	Between FB1-14 and C36 (female) (3)	Max. 1 Ω
			Between C36 (female) (5) and LST4 (female) (2)	Max. 1 Ω
			Between LST4 (female) (3) and LST1 (female) (8)	Max. 1 Ω
5	Ground fault in wiring harness (power supply line)	1. Starting switch OFF 2. Remove the fuse No. 14 in fuse box FB1. 3. Disconnect the connectors C36, LST1, LST4, LST5, LST6, SAS, SL1, TM39, TM40. 4. Connect the T-adapter to the female side of connectors C36, LST1 and LST4.		
		Resistance	Between ground and FB1-14 or C36 (female) (3)	Min. 1 MΩ
			Between ground and C36 (female) (5) or LST4 (female) (2)	Min. 1 MΩ
			Between ground and LST4 (female) (3) or LST1 (female) (8)	Min. 1 MΩ
6	Hot short circuit in wiring harness (power supply line)	1. Starting switch OFF 2. Remove the fuse No. 14 in fuse box FB1. 3. Disconnect the connectors C36, LST1, LST4, LST5, LST6, SAS, SL1, TM39, TM40. 4. Connect the T-adapter to the female side of connectors C36, LST1 and LST4. 5. Starting switch ON		
		Voltage	Between ground and FB1-14 or C36 (female) (3)	Max. 1 V
			Between ground and C36 (female) (5) or LST4 (female) (2)	Max. 1 V
			Between ground and LST4 (female) (3) or LST1 (female) (8)	Max. 1 V

No.	Cause	Procedure, measuring location, criteria and remarks		
4	Open circuit in wiring harness (power supply line)	1. Starting switch OFF 2. Remove the fuse No. 14 in fuse box FB1. 3. Disconnect the connectors LST1, LST4 and C36. Connect the T-adapter to each female side.		
		Resistance	Between FB1-14 and C36 (female) (3)	Max. 1 Ω
			Between C36 (female) (5) and LST4 (female) (2)	Max. 1 Ω
			Between LST4 (female) (3) and LST1 (female) (8)	Max. 1 Ω
5	Ground fault in wiring harness (power supply line)	1. Starting switch OFF 2. Remove the fuse No. 14 in fuse box FB1. 3. Disconnect the connectors C36, LST1, LST4, LST5, LST6, SAS, SL1, TM39, TM40. 4. Connect the T-adapter to the female side of connectors C36, LST1 and LST4.		
		Resistance	Between ground and FB1-14 or C36 (female) (3)	Min. 1 MΩ
			Between ground and C36 (female) (5) or LST4 (female) (2)	Min. 1 MΩ
			Between ground and LST4 (female) (3) or LST1 (female) (8)	Min. 1 MΩ
6	Hot short circuit in wiring harness (power supply line)	1. Starting switch OFF 2. Remove the fuse No. 14 in fuse box FB1. 3. Disconnect the connectors C36, LST1, LST4, LST5, LST6, SAS, SL1, TM39, TM40. 4. Connect the T-adapter to the female side of connectors C36, LST1 and LST4. 5. Starting switch ON		
		Voltage	Between ground and FB1-14 or C36 (female) (3)	Max. 1 V
			Between ground and C36 (female) (5) or LST4 (female) (2)	Max. 1 V
			Between ground and LST4 (female) (3) or LST1 (female) (8)	Max. 1 V

No.	Cause	Procedure, measuring location, criteria and remarks		
7	CAN disconnection	1. Starting switch: OFF 2. Disconnect the connector LST6. Connect the T-adapter to the female side.  <b>REMARK</b> <ul style="list-style-type: none"> <li>• CAN terminating resistors of 120 Ω are connected in parallel. When the circuit resistance is measured at the connector of travel sensor converter, if the combined resistance is 60 Ω, the wiring harness is normal.</li> </ul>		
		Resistance	Between LST6 (female) (3) and (4)	approximately 60 Ω
		If a failure is found by the previous checks, measure the resistance of the termination resistor. 1. Starting switch: OFF 2. Disconnect the connectors T10A and T10B. Connect the T-adapter to each male side.		
		Resistance	Between T10A (male) (A) and (B)	120±12 Ω
Between T10B (male) (A) and (B)	120±12 Ω			
8	Defective travel speed sensor converter	Replace the travel speed sensor converter.		
9	Defective steering valve assembly	Replace the steering valve assembly.		

**Failure Code [#Q0517]**

Action level	Failure code	Failure	Abnormality of VSS 3 (S/T) (Sub) (Transmission controller system)
L03	#Q0517		
Details of failure	<ul style="list-style-type: none"> <li>CAN communication with the vehicle speed sensor converter is defective.</li> <li>There is an incorrect data in the communication of the travel speed sensor.</li> </ul>		
Action of controller	<ul style="list-style-type: none"> <li>Lights up the centralized warning lamp and makes the alarm buzzer sound.</li> <li>Even if the cause of the failure no longer exists, the machine does not go back to normal until the steering control lever enable switch is turned to the OFF position and then to the ON position.</li> </ul>		
Phenomenon on machine	It becomes not possible to steer with the steering control lever.		
Related information	<ul style="list-style-type: none"> <li>It is possible to steer with the steering wheel.</li> <li>The transmission controller energizes the power supply relay for the steering control lever to supply power to the components related to the steering control lever only when the starting switch is in the ON position and the operator is in the seat.</li> </ul>		

No.	Cause	Procedure, measuring location, criteria and remarks		
1	Open circuit in wiring harness (power supply line)	<ol style="list-style-type: none"> <li>Starting switch OFF</li> <li>Remove the fuse No. 14 in fuse box FB1.</li> <li>Disconnect the connectors LST5, LST6 and LST4. Connect the T-adapter to each female side.</li> </ol>		
		Resistance	Between LST4 (female) (3) and LST5 (female) (1)	Max. 1 Ω
			Between LST4 (female) (3) and LST6 (female) (2)	Max. 1 Ω
			Between LST6 (female) (1) and LST4 (female) (6)	Max. 1 Ω
2	Ground fault in wiring harness (power supply line)	<ol style="list-style-type: none"> <li>Starting switch OFF</li> <li>Remove the fuse No. 14 in fuse box FB1.</li> <li>Disconnect the connectors C36, LST1, LST4, LST5, LST6, SAS, SL1, TM39, TM40.</li> <li>Connect the T-adapter to the each female side of connectors C36, LST4, LST5, LST6.</li> </ol>		
		Resistance	Between ground and FB1-14 or C36 (female) (3)	Min. 1 MΩ
			Between ground and C36 (female) (5) or LST4 (female) (2)	Min. 1 MΩ
			Between ground and LST4 (female) (3), LST5 (female) (1) or LST6 (female) (2)	Min. 1 MΩ

**Failure Code [#Q0528]**

Action level	Failure code	Failure	Abnormality of EH spool 1 (S/T) (Sub) (Transmission controller system)
L03	#Q0528		
Details of failure	There is an abnormality of the spool in the steering valve assembly.		
Action of controller	<ul style="list-style-type: none"> <li>Lights up the centralized warning lamp and makes the alarm buzzer sound.</li> <li>Even if the cause of the failure no longer exists, the machine does not go back to normal until the steering control lever enable switch is turned to the OFF position and then to the ON position.</li> </ul>		
Phenomenon on machine	It becomes not possible to steer with the steering control lever.		
Related information	<ul style="list-style-type: none"> <li>It is possible to steer with the steering wheel.</li> <li>The transmission controller energizes the power supply relay for the steering control lever to supply power to the components related to the steering control lever only when the starting switch is in the ON position and the operator is in the seat.</li> </ul>		

No.	Cause	Procedure, measuring location, criteria and remarks			
1	Defective fuse	If the fuse No.14 in fuse box FB1 is burnt out, the circuit possibly has a ground fault. (See check on cause of wiring harness ground fault (power supply line))			
2	Defective steering lever enable switch	1. Starting switch: OFF 2. Disconnect the connector LST4. Connect the T-adapter to the male side.			
		Voltage	Between LST4 (male) (2) and LST4 (male) (3)	Steering lever enable switch: Enabled	Max. 1 Ω
				Steering lever enable switch: Disabled	Min. 1 MΩ
		Voltage	Between LST4 (male) (5) and LST4 (male) (6)	Steering lever enable switch: Enabled	Max. 1 Ω
				Steering lever enable switch: Disabled	Min. 1 MΩ
		Voltage	Between LST4 (male) (2) and LST4 (male) (1)	Steering lever enable switch: Enabled	Min. 1 MΩ
				Steering lever enable switch: Disabled	Max. 1 Ω
		Voltage	Between LST4 (male) (5) and LST4 (male) (4)	Steering lever enable switch: Enabled	Min. 1 MΩ
Steering lever enable switch: Disabled	Max. 1 Ω				
3	Open circuit in wiring harness (power supply line)	1. Starting switch OFF 2. Remove the fuse No. 14 in fuse box FB1. 3. Disconnect the connectors LST1, LST4 and C36. Connect the T-adapter to each female side.			
		Resistance	Between FB1-14 and C36 (female) (3)	Max. 1 Ω	
			Between C36 (female) (5) and LST4 (female) (2)	Max. 1 Ω	
			Between LST4 (female) (3) and LST1 (female) (8)	Max. 1 Ω	

No.	Cause	Procedure, measuring location, criteria and remarks			
5	Defective fuse	If the fuse No.14 in fuse box FB1 is burnt out, the circuit possibly has a ground fault. (See check on cause of wiring harness ground fault (power supply line))			
6	Defective steering lever enable switch	1. Starting switch: OFF 2. Disconnect the connector LST4. Connect the T-adapter to the male side.			
		Voltage	Between LST4 (male) (2) and LST4 (male) (3)	Steering lever enable switch: Enabled	Max. 1 Ω
				Steering lever enable switch: Disabled	Min. 1 MΩ
		Voltage	Between LST4 (male) (5) and LST4 (male) (6)	Steering lever enable switch: Enabled	Max. 1 Ω
				Steering lever enable switch: Disabled	Min. 1 MΩ
		Voltage	Between LST4 (male) (2) and LST4 (male) (1)	Steering lever enable switch: Enabled	Min. 1 MΩ
				Steering lever enable switch: Disabled	Max. 1 Ω
		Voltage	Between LST4 (male) (5) and LST4 (male) (4)	Steering lever enable switch: Enabled	Min. 1 MΩ
				Steering lever enable switch: Disabled	Max. 1 Ω
		7	Open circuit in wiring harness (power supply line)	1. Starting switch OFF 2. Remove the fuse No. 14 in fuse box FB1. 3. Disconnect the connectors LST1, LST4 and C36. Connect the T-adapter to each female side.	
Resistance	Between FB1-14 and C36 (female) (3)			Max. 1 Ω	
	Between C36 (female) (5) and LST4 (female) (2)			Max. 1 Ω	
	Between LST4 (female) (3) and LST1 (female) (8)			Max. 1 Ω	
8	Ground fault in wiring harness (power supply line)	1. Starting switch OFF 2. Remove the fuse No. 14 in fuse box FB1. 3. Disconnect the connectors C36, LST1, LST4, LST5, LST6, SAS, SL1, TM39, TM40. 4. Connect the T-adapter to the female side of connectors C36, LST1 and LST4.			
		Resistance	Between ground and FB1-14 or C36 (female) (3)	Min. 1 MΩ	
			Between ground and C36 (female) (5) or LST4 (female) (2)	Min. 1 MΩ	
			Between ground and LST4 (female) (3) or LST1 (female) (8)	Min. 1 MΩ	

No.	Cause	Procedure, measuring location, criteria and remarks		
4	Ground fault in wiring harness (power supply line)	<ol style="list-style-type: none"> <li>1. Starting switch OFF</li> <li>2. Remove the fuse No. 14 in fuse box FB1.</li> <li>3. Disconnect the connectors C36, LST1, LST4, LST5, LST6, SAS, SL1, TM39, TM40.</li> <li>4. Connect the T-adapter to the female side of connectors C36, LST1 and LST4.</li> </ol>		
		Resistance	Between ground and FB1-14 or C36 (female) (3)	Min. 1 MΩ
			Between ground and C36 (female) (5) or LST4 (female) (2)	Min. 1 MΩ
			Between ground and LST4 (female) (3) or LST1 (female) (8)	Min. 1 MΩ
5	Hot short circuit in wiring harness (power supply line)	<ol style="list-style-type: none"> <li>1. Starting switch OFF</li> <li>2. Remove the fuse No. 14 in fuse box FB1.</li> <li>3. Disconnect the connectors C36, LST1, LST4, LST5, LST6, SAS, SL1, TM39, TM40.</li> <li>4. Connect the T-adapter to the female side of connectors C36, LST1 and LST4.</li> <li>5. Starting switch ON</li> </ol>		
		Voltage	Between ground and FB1-14 or C36 (female) (3)	Max. 1 V
			Between ground and C36 (female) (5) or LST4 (female) (2)	Max. 1 V
			Between ground and LST4 (female) (3) or LST1 (female) (8)	Max. 1 V
6	Defective steering valve assembly	Replace the steering valve assembly.		

### Circuit Diagram of the Steering Control Lever

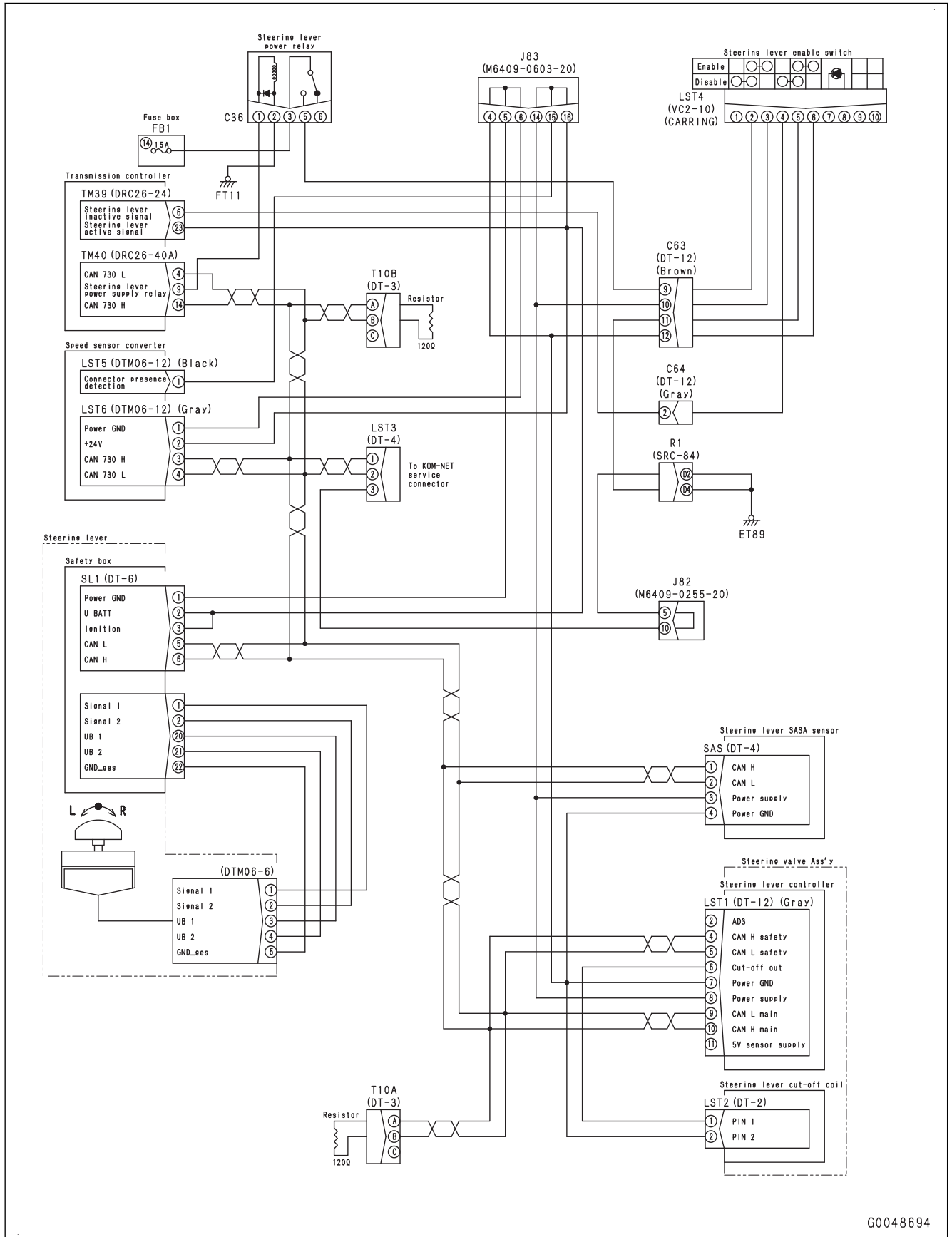

G0048694

No.	Cause	Procedure, measuring location, criteria and remarks		
4	Open circuit in wiring harness (power supply line)	1. Starting switch OFF 2. Remove the fuse No. 14 in fuse box FB1. 3. Disconnect the connectors LST1, LST4 and C36. Connect the T-adapter to each female side.		
		Resistance	Between FB1-14 and C36 (female) (3)	Max. 1 Ω
			Between C36 (female) (5) and LST4 (female) (2)	Max. 1 Ω
			Between LST4 (female) (3) and LST1 (female) (8)	Max. 1 Ω
5	Ground fault in wiring harness (power supply line)	1. Starting switch OFF 2. Remove the fuse No. 14 in fuse box FB1. 3. Disconnect the connectors C36, LST1, LST4, LST5, LST6, SAS, SL1, TM39, TM40. 4. Connect the T-adapter to the female side of connectors C36, LST1 and LST4.		
		Resistance	Between ground and FB1-14 or C36 (female) (3)	Min. 1 MΩ
			Between ground and C36 (female) (5) or LST4 (female) (2)	Min. 1 MΩ
			Between ground and LST4 (female) (3) or LST1 (female) (8)	Min. 1 MΩ
6	Hot short circuit in wiring harness (power supply line)	1. Starting switch OFF 2. Remove the fuse No. 14 in fuse box FB1. 3. Disconnect the connectors C36, LST1, LST4, LST5, LST6, SAS, SL1, TM39, TM40. 4. Connect the T-adapter to the female side of connectors C36, LST1 and LST4. 5. Starting switch ON		
		Voltage	Between ground and FB1-14 or C36 (female) (3)	Max. 1 V
			Between ground and C36 (female) (5) or LST4 (female) (2)	Max. 1 V
			Between ground and LST4 (female) (3) or LST1 (female) (8)	Max. 1 V

### Circuit Diagram of the Travel Speed Sensor

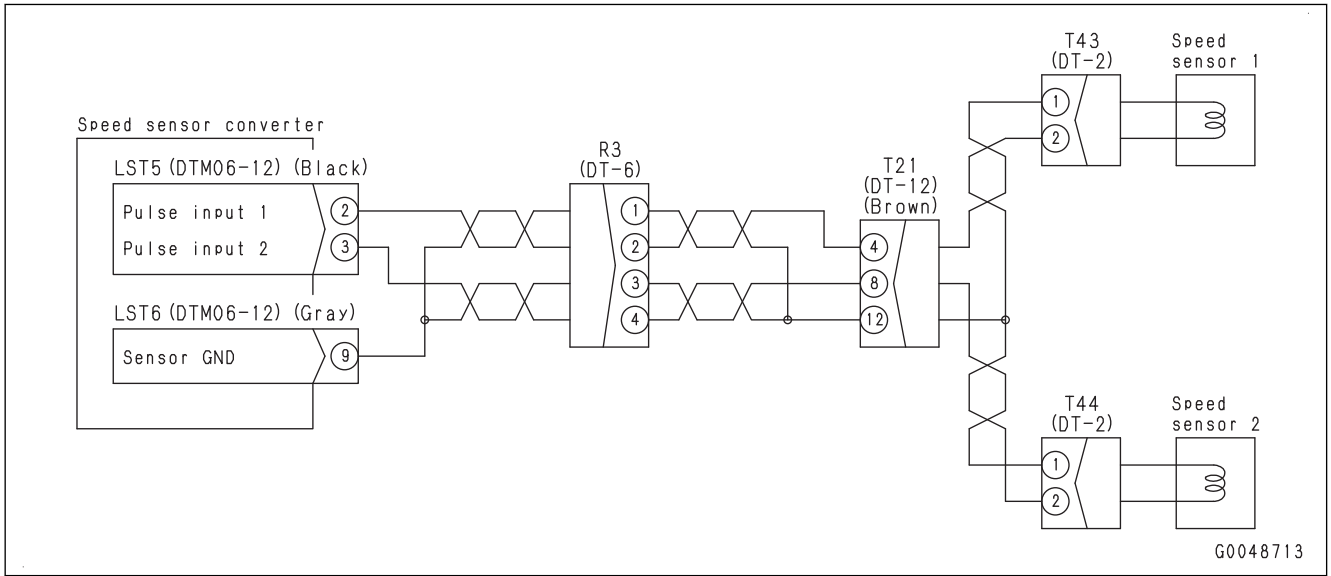

### E-4 While Preheating is in Operation, Preheating Pilot Lamp Does Not Come On

Failure	While preheating is in operation, the preheating pilot lamp does not light up.
Related information	<ul style="list-style-type: none"> <li>This machine has "Automatic preheating function" and "Manual preheating function". When one of them operates, the engine preheating monitor lights up.</li> <li>Make sure whether the manual preheating function operates first.</li> <li>A "Socket-type box" is available for the monitor controller connector.</li> </ul>

No.	Cause	Procedure, measuring location, criteria, and remarks		
1	Open circuit in wiring harness	1. Starting switch OFF 2. Make sure that the system operating lamp is not lit. Turn the battery disconnect switch to the OFF position. 3. Disconnect the connectors MCM1 A and S40. Connect the T-adaptor to each female side.		
		Resistance	Between S40 (female) (5) and MCM1 A (female) (12)	Max. 1 Ω
2	Defective monitor controller	If no failure is found by the previous checks, the monitor controller is defective. (Since this is an internal defect, troubleshooting cannot be performed).		

### E-24 Brake Oil Pressure Caution Lamp Does Not Come On When Rear Brake Accumulator Oil Pressure is Low

Failure	Brake oil pressure caution lamp does not light up when rear brake accumulator oil pressure is low
Related information	<ul style="list-style-type: none"> <li>If failure code [2G43ZG] is shown, do the troubleshooting for that code first.</li> <li>Short circuit or ground fault in rear brake accumulator oil pressure switch circuit</li> <li>When the brake oil pressure lowers, the brake accumulator oil pressure switch turns OFF when it is normal.</li> <li>You can check the input signal from the rear brake accumulator oil pressure switch with the monitoring function. (Code: 04510) (ON/OFF)</li> </ul>

No.	Cause	Procedure, measuring location, criteria and remarks				
1	Defective rear brake accumulator oil pressure switch	1. Starting switch OFF 2. Make sure that the brake oil pressure is max. 3.9 MPa {max. 40 kgf/cm <sup>2</sup> } . 3. Disconnect the connector R16. Connect the T-adapter to the male side.				
		<table border="1"> <tr> <td>Resistance</td> <td>Between R16 (male) (1) and (2)</td> <td>Min. 1 MΩ</td> </tr> <tr> <td></td> <td>Between R16 (male) (1) and ground</td> <td>Min. 1 MΩ</td> </tr> </table>	Resistance	Between R16 (male) (1) and (2)	Min. 1 MΩ	
Resistance	Between R16 (male) (1) and (2)	Min. 1 MΩ				
	Between R16 (male) (1) and ground	Min. 1 MΩ				
2	Ground fault in wiring harness	1. Starting switch OFF 2. Make sure that the system operating lamp is not lit. Turn the battery disconnect switch to the OFF position. 3. Disconnect the connectors MCM1 A and R16. Connect the T-adapter to one of them on the female side.				
		<table border="1"> <tr> <td>Resistance</td> <td>Between ground and MCM1 A (female) (72) or R16 (female) (1)</td> <td>Min. 1 MΩ</td> </tr> </table>	Resistance	Between ground and MCM1 A (female) (72) or R16 (female) (1)	Min. 1 MΩ	
Resistance	Between ground and MCM1 A (female) (72) or R16 (female) (1)	Min. 1 MΩ				
3	Defective monitor controller	If no failure is found by the previous checks, the monitor controller is defective. (Since this is an internal defect, troubleshooting cannot be done.)				

### Circuit Diagram of Brake Accumulator

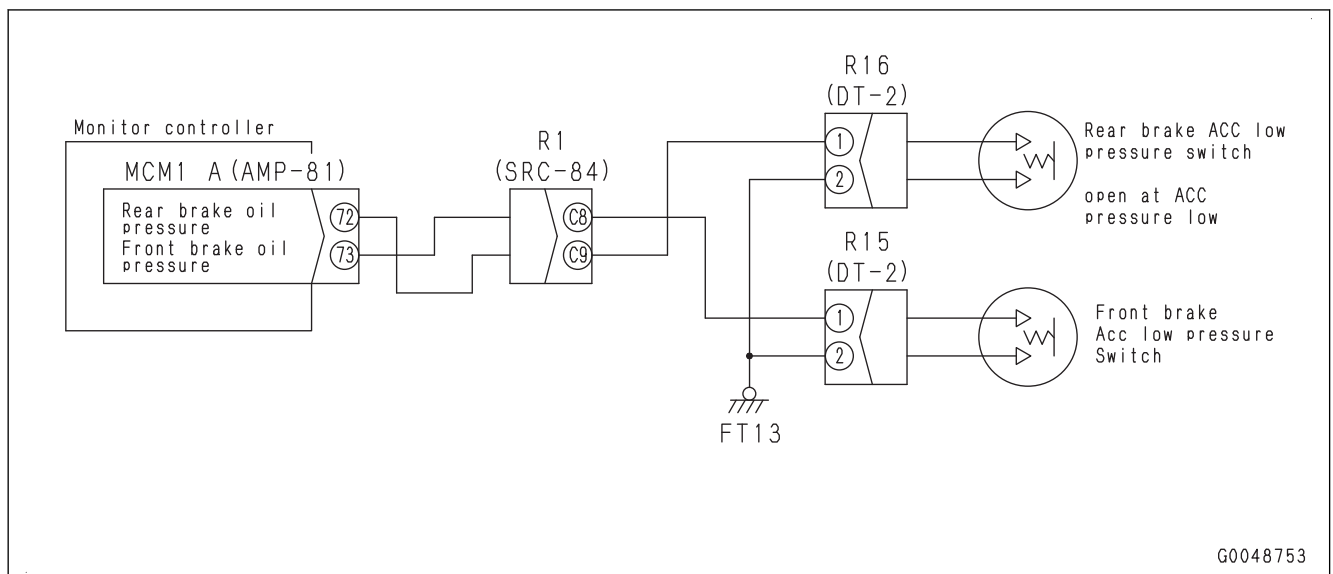

### E-49 Headlamp Selection (Low or High Beam) Cannot be Done

Failure	Headlamp selection (low or high beam) cannot be done
Related information	<ul style="list-style-type: none"> <li>The dimmer switch and dimmer relay (SP11) makes the changeover between high beam and low beam.</li> <li>You can check the input signal (ON/OFF) from the dimmer switch (high beam) with the monitoring function. (Code: 04507)</li> </ul>

No.	Cause	Procedure, measuring location, criteria and remarks			
1	Burned-out lamp bulb	If only one headlamp does not light up, inspect it for a burned-out bulb or defective contact.			
2	Defective dimmer relay	<ol style="list-style-type: none"> <li>Starting switch OFF</li> <li>Replace dimmer relay SP11 with a relay of the same type.</li> <li>Starting switch ON</li> <li>Lamp switch ON</li> <li>Turn ON/OFF dimmer switch</li> </ol> <p>If a changeover between high beam and low beam occurs, the original dimmer relay is defective.</p>			
3	Defective dimmer switch	<ol style="list-style-type: none"> <li>Starting switch OFF</li> <li>Disconnect the connectors FP10 and FP11. Connect the T-adaptor to each male side.</li> <li>Turn the lamp switch to HEAD.</li> <li>Operate dimmer switch to do the troubleshooting</li> </ol>			
		Resistance	Between FP11 (male) (5) and FP10 (male) (6) (High beam)	Dimmer switch: ON	Max. 1 Ω
				Dimmer switch: OFF	Min. 1 MΩ
			Between FP10 (male) (8) and FP11 (male) (10) (Low beam)	Dimmer switch: ON	Min. 1 MΩ
	Dimmer switch: OFF		Max. 1 Ω		

## E-64 Left Door Wiper Does Not Operate

Failure	Left door wiper does not operate
Related information	<ul style="list-style-type: none"> <li>If none of the wipers operate, see “No Wiper Operates” in E mode.</li> <li>If the front wiper also does not operate, see E-mode “Front wiper does not operate”.</li> <li>If the right and left door wipers do not operate, see “Right and Left Door Wipers Do Not Operate”.</li> <li>The door intermittent wiper relay starts and stops the intermittent operation of the door wiper based on the intermittent signal from the front wiper switch.</li> <li>Though a T-adaptor is not provided for wiper intermittent unit C54, inspect the wiring harness of wiper intermittent unit C54 for open circuits.</li> </ul>

No.	Cause	Procedure, measuring location, criteria and remarks			
1	Defective left door wiper motor	1. Starting switch OFF 2. Disconnect the connector C11. Connect the T-adaptor to the male side.			
		Continuity	Between C11 (male) (2) and (4)	Continuity	
2	Defective door wiper intermittent unit	<b>REMARK</b> Make sure that the rear wiper operates normally.			
		1. Starting switch OFF 2. Disconnect the connectors C53 and C54. Interchange the wiper intermittent units with each other. 3. Starting switch ON 4. Troubleshoot with the front wiper switch in Lo and intermittent positions  If the L.H. door wiper becomes normal in Lo and intermittent, the original door wiper intermittent unit is defective.			
3	Open circuit in wiring harness	Wiper motor 1. Starting switch OFF 2. Disconnect the connector C11. Connect the T-adaptor to the female side. 3. Starting switch ON 4. Put wiper switch in and out of Lo position to do the troubleshooting			
		Voltage	Between C11 (female) (1) and (4)	20 to 30 V	
			Between C11 (female) (2) and (4)	Front Lo	20 to 30 V
			Between C11 (female) (2) and (4)	Front OFF	0 V
		Check for pin 5 and pin 7 of C54 1. Starting switch OFF 2. Disconnect the connector C11. Connect the T-adaptor to the female side.			
Resistance	Between C11 (female) (2) and (3)	Max. 1 Ω			
4	Ground fault in wiring harness	If no abnormality is found in the wiper motor by the troubleshooting for open circuit in the wiring harness, this check is not required.			
		1. Starting switch OFF 2. Disconnect the connectors C11 and C54. Connect the T-adaptor to the female side of C11.			
		Resistance	Between C11 (female) (2) and ground	Min. 1 MΩ	
Between C11 (female) (3) and ground	Min. 1 MΩ				

**H-8 Time Lag is Large When You Start Machine or Shift Gears**

Failure	Time lag is large when you start machine or shift gears
Related information	<ul style="list-style-type: none"> <li>• Check that the oil level in the transmission case is normal.</li> <li>• If a failure code is shown, do the troubleshooting for that failure code first (15SBL1, 15SBMA, 15SCL1, 15SCMA, 15SDL1, 15SDMA, 15SEL1, 15SEMA, 15SFL1, 15SFMA, 15SGL1, 15SGMA, 15SHL1, 15SHMA, 15SJMA).</li> <li>• If a failure code is shown, do the troubleshooting for that failure code first(DXH2KY, DXH3KY, DXH4KY, DXH5KY, DXH6KY, DXH7KY, DXHHKY)(Applicable Machine: 65482 and up).</li> <li>• Do an oil pressure check with the torque converter oil temperature at 60 to 80 °C and the transmission oil temperature at 60 to 80 °C.</li> <li>• Operate the gear shift lever to each gear speed to check the gear speed or the forward-reverse with large time lag before troubleshooting.</li> <li>• Check that the travel speed is normal before troubleshooting. (If it is not normal, troubleshoot for “TRAVEL SPEED OR POWER IS LOW” and “TRAVEL SPEED OR POWER IS LOW IN CERTAIN GEAR ” in H-mode first.)</li> </ul>

## S-9 KDPF Becomes Clogged in a Short Time

Failure	KDPF gets clogged in a short times
Related information	<p>If any failure code is displayed, perform troubleshooting for that code first.</p> <p><b>NOTICE</b></p> <p><b>If this failure is occurring, it indicates that KCSF may be damaged. After completing the repair of the problem, check the following. Replace the KCSF if the black smoke comes out of the exhaust pipe outlet.</b></p> <ul style="list-style-type: none"> <li>Start the engine, perform the quick acceleration from low idle to high idle two times, and then keep the engine running at high idle for 5 seconds.</li> <li>Check that the black smoke does not come out of the exhaust pipe outlet during this quick acceleration and high idling.</li> </ul>

No.	Cause	Point to check, remarks	Remedy
1	Foreign materials are mixed into fuel.	If drain fuel from fuel tank, rust or water comes out.	Fuel replacement
2	Defective air cleaner	Check air cleaner and rectifying wire net for deformation.	Air cleaner repair or replacement
3	Defective exhaust pipe (between exhaust manifold and KDPF inlet)	Check exhaust pipes for damage and exhaust gas leakage (Check heat insulation cover and soot on heat insulation plate)	Exhaust piping replacement
4	Defective installation of charge (boost) pressure sensor	Air leakage through mounting portion of charge pressure sensor	Repair installation of charge pressure sensor
5	Defective boost piping and connection (between VGT outlet and intake manifold)	Air comes out of boost piping.	Boost piping repair or replacement
6	Gas leakage from EGR piping	Gas leaking from EGR piping.	Replace EGR piping
7	VGT seizure and damage	<ul style="list-style-type: none"> <li>Unusual noise is heard from VGT.</li> <li>Check if VGT shaft can rotate (by manually moving the VGT's blade axially and vertically).</li> </ul>	VGT replacement
8	Defective injector	<ul style="list-style-type: none"> <li>Some cylinder is found to be cool when exhaust manifolds are touched by hand immediately after engine is started.</li> <li>Perform cylinder cutout mode operation to identify cylinder that does not change in speed (see "30 Testing and Adjusting", "HANDLING CYLINDER CUTOFF MODE OPERATION").</li> </ul>	Replace injector.
9	Defective fuel return piping	When checking fuel return rate, fuel return rate is excessive. (Reference: See Testing and adjusting, "Testing fuel return rate and leakage".)	Fuel return piping repair or replacement
10	Defective mass air flow and temperature sensor	Replace a sensor, and check if it operates normally (failure code may be displayed due to dust attached to sensor).	Mass air flow and temperature sensor replacement
11	Defective valve clearance	<ul style="list-style-type: none"> <li>When engine is operated, unusual noise is heard from around cylinder head.</li> <li>Check valve clearance (Reference: See Testing and adjusting, "Testing and adjusting valve clearance").</li> </ul>	Valve clearance adjustment

**Tools for Removal and Installation of Control Valve Assembly**

Symbol		Part name	Part No.	Specifications	Q'ty	Remarks
A	1	Plug (female)	02789-00315	Nominal 03	24	
	2	Plug (male)	07376-70315	Nominal 03	24	
	3	O-ring	02896-11009		24	
B	1	Plug (female)	02789-00422	Nominal 04	1	
	2	Plug (male)	07376-70422	Nominal 04	1	
	3	O-ring	02896-11012		1	
C	1	Plug (female)	02789-00628	Nominal 06	4	
	2	Plug (male)	07376-70628	Nominal 06	4	
	3	O-ring	02896-11018		4	

**Tools for Removal and Installation of Ripper Assembly**

Symbol		Part name	Part No.	Specifications	Q'ty	Remarks
A	1	Plug (female)	02789-00315	Nominal 03	2	
	2	Plug (male)	07376-70315	Nominal 03	2	
	3	O-ring	02896-11009		2	

**Tools for Removal and Installation of the Circle and Drawbar Assembly**

Symbol		Part name	Part No.	Specifications	Q'ty	Remarks
A	1	Plug (female)	02789-00315	Nominal 03	6	
	2	Plug (male)	07376-70315	Nominal 03	6	
	3	O-ring	02896-11009		6	
B	1	Plug (female)	02789-00422	Nominal 04	2	
	2	Plug (male)	07376-70422	Nominal 04	2	
	3	O-ring	02896-11012		2	

**Tools for Removal and Installation of Circle Rotation Gear Assembly**

Symbol		Part name	Part No.	Specifications	Q'ty	Remarks
A	1	Plug (female)	02789-00422	Nominal 04	2	
	2	Plug (male)	07376-70422	Nominal 04	2	
	3	O-ring	02896-11012		2	

**Tools for Disassembly and Assembly of the Circle Rotation Gear Assembly**

Symbol		Part name	Part No.	Specifications	Q'ty	Remarks
A		Forcing screw	790-201-3230		2	Removal of case
B		Guide bolt	790-201-3120		2	Installation of case

- Make sure that there is no steps part (d) (2 mm from the front end) you can feel by your fingernails or fatigue.

19. Tighten the sleeve nuts of the high-pressure pipes (29), (30), (31), (32), (33), and (34) lightly.

Tool: Ratchet handle, socket, torque wrench

High-pressure pipe (29), (30), (31), (32), (33), (34): Width across flats 19 mm

 High-pressure pipe (29), (30), (31), (32), (33), (34) (tightening lightly): 0.2 to 0.8 Nm {0.02 to 0.08 kgm}

20. Tighten the sleeve nuts of the high-pressure pipes (29), (30), (31), (32), (33), and (34) to the specified torque as follows.

1) High-pressure pipe ((29): connector side) -> ((30): connector side) -> ((31): connector side) -> ((29): common rail side) -> ((30): common rail side) -> ((31): common rail side)

2) High-pressure pipe ((32): connector side) -> ((33): connector side) -> ((34): connector side) -> ((32): common rail side) -> ((33): common rail side) -> ((34): common rail side)

Tool: Ratchet handle, socket, torque wrench

Sleeve nut for high-pressure pipe (29), (30), (31), (32), (33), (34): Width across flats 19 mm

 Sleeve nut (tightening to specified torque): 35±3.5 Nm {3.57±0.36 kgm}

21. Install the fuel spray prevention caps (28) (12 pieces) of the high-pressure pipes (29), (30), (31), (32), (33), and (34).

**⚠ Install the fuel spray prevention caps with their slit toward out and down.**

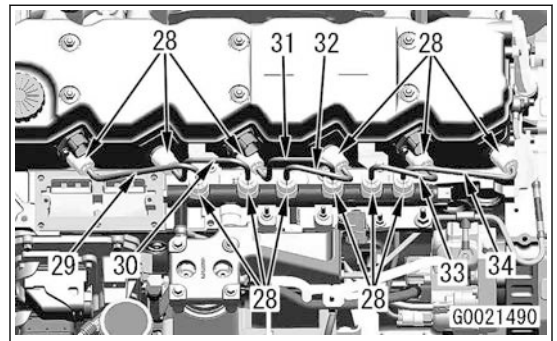
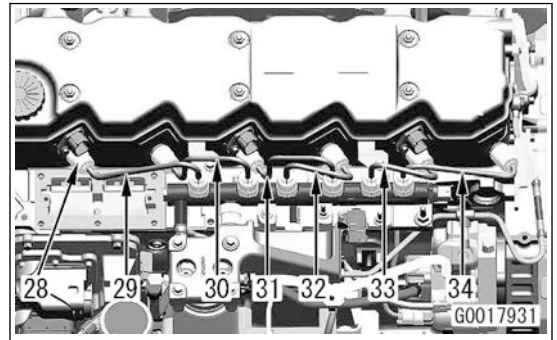

**Intake assembly**

22. Set the gasket (27a) to the installation position.

23. Install the intake assembly (27) with the bolts (26a) (4 pieces) and (26b) (2 pieces).

Tool: Ratchet handle, socket, torque wrench

Bolt (26a): Width across flats 11 mm, M8

Bolt (26b): Width across flats 10 mm, M8

 Bolt (26a), (26b): 24±4 Nm {2.45±0.41 kgm}

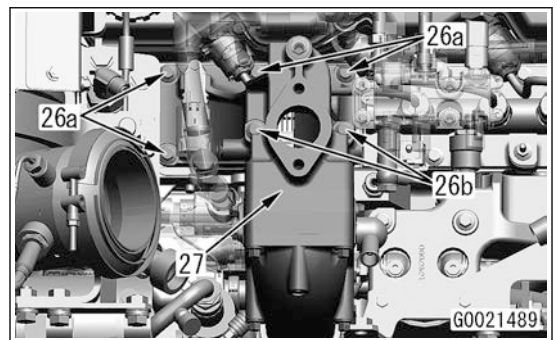
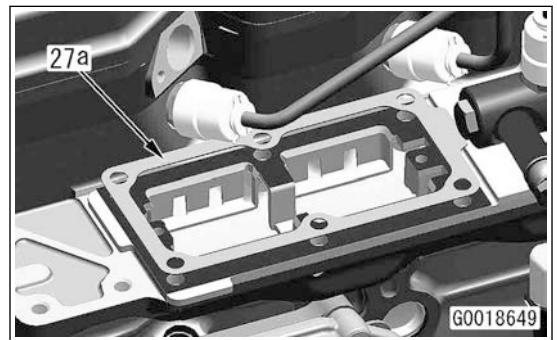

- Install the lock pin (1) to the installation position (b).

**REMARK**

Insert the lock pin (1) to the stowage part, and then install the pin (1) securely.

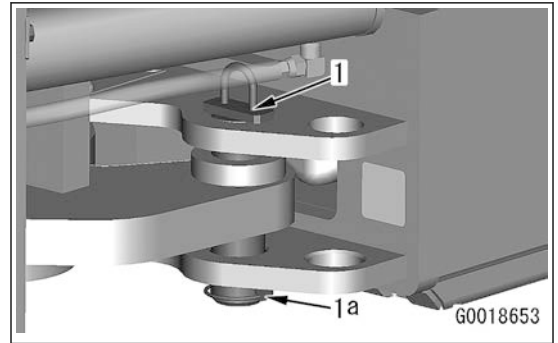
**Cover**

- Open the cover (2).

**NOTICE**

**Make sure that the lock is securely applied.**

- Remove the bolts (3a) and (3b) (2 pieces), and remove the cover (4).

Tool: Impact wrench, socket

Bolt (3a): Width across flats 14 mm, M10

Bolt (3b): Width across flats 17 mm, M10

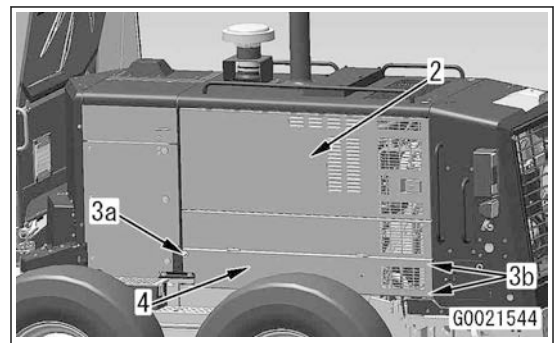
**Connector**

- Remove the clamps (6) (2 pieces), and disconnect the connector R21 (5).

Tool: Ratchet handle, socket

Bolt for clamp (6): Width across flats 17 mm, M10

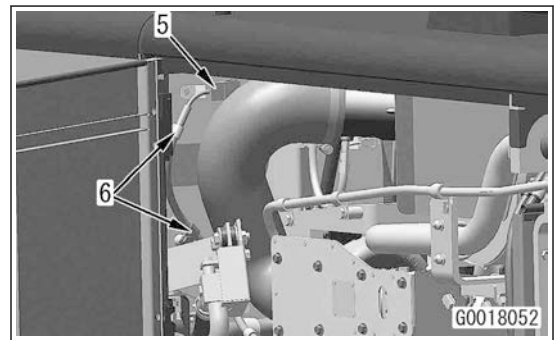

- Remove the clamps (7a) (2 pieces), and move the hose (7) to a safe place not to interfere with the work.

Tool: Ratchet handle, socket

Bolt for clamp (7a): Width across flats 17 mm, M10

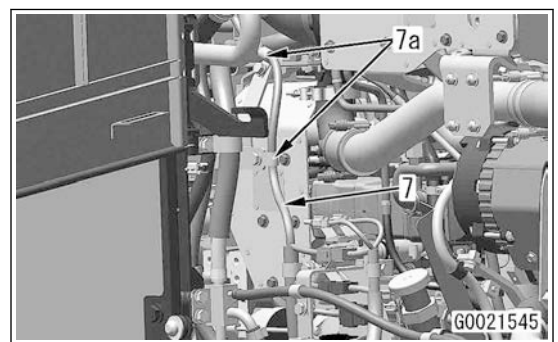

- Remove the bolts (8) (6 pieces), and remove the heat insulation plate (9).

Tool: Impact wrench, socket

Bolt (8): Width across flats 14 mm, M10

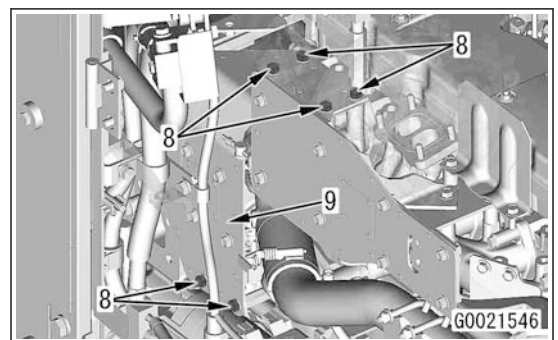

## Remove and Install Cooling Fan Motor Assembly

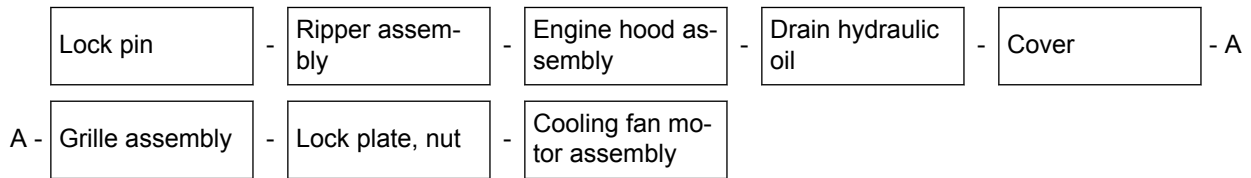

### Standard tool list

The listed parts are for reference only. You can use the part that is not listed if it is applicable.

No.	Part name	Part No.	Specifications	Q'ty	Remarks
1	Open-end wrench	Commercially available	32 mm	1	
2	Socket wrench	Commercially available	17 mm	1	
3	Socket wrench	Commercially available	19 mm	1	
4	Socket wrench	Commercially available	30 mm	1	
5	Socket wrench	Commercially available	36 mm	1	
6	Torque wrench	Commercially available	40 to 200 Nm	1	
7	Oil container	Commercially available		As required	
8	Webbing sling	Commercially available		1	
9	Lifting tool	Commercially available		1	

### Special Tools List

Symbol	Part name	Part No.	Specifications	Q'ty	Remarks
A	Gear puller	790-101-3501		1	Removal of cooling fan motor assembly
B	1 Plug (female)	02789-00522	Nominal 05	3	
	2 Plug (male)	07376-70522	Nominal 05	3	
	3 O-ring	02896-11015		3	

**⚠ Stop the machine on level ground, lower the work equipment to the ground and lock it with the work equipment lock switch, and then apply the brake with the parking brake switch.**

**⚠ Stop the engine, and chock the tires.**

**⚠ Set the battery disconnect switch to the OFF position, and remove the key. (For details, see Testing and Adjusting, "Handle Battery Disconnect Switch".)**

**Cover**

3. Open the side covers (2) (right and left).

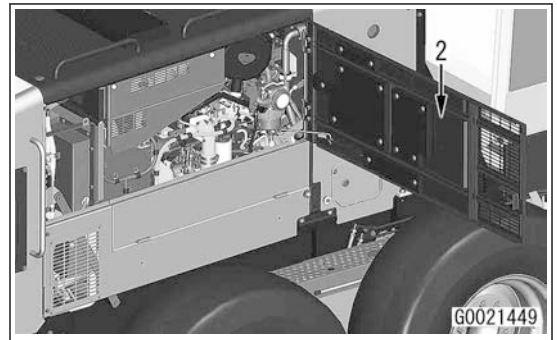
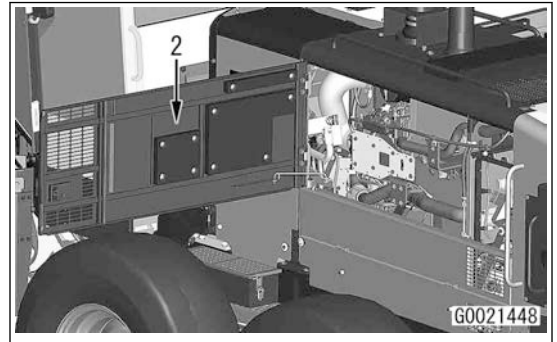

4. Remove the clamps (3) (6 pieces) at the right side of the machine, and remove the cover (4).

Tool: Impact wrench, socket

Bolt for clamp (3): Width across flats 17 mm, M10

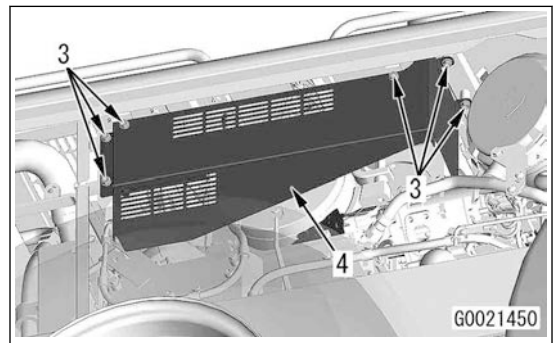
**Clamp, hose**

5. Remove the clamp (5) at the right side of the machine.

Tool: Impact wrench, socket

Bolt for clamp (5): Width across flats 17 mm, M10

6. Remove the clips (6a) (2 pieces), and disconnect the coolant hoses (6) (2 pieces).

**NOTICE**

- When you disconnect the coolant hoses (6) (2 pieces), be sure that coolant does not splash the KDPF assembly and SCR assembly.
- After you disconnect the coolant hoses (6) (2 pieces), be sure that the coolant does not leak.
- Install the cap (C1) to the pin side to prevent coolant leakage.

Tool: Cap (C1), pliers, coolant container

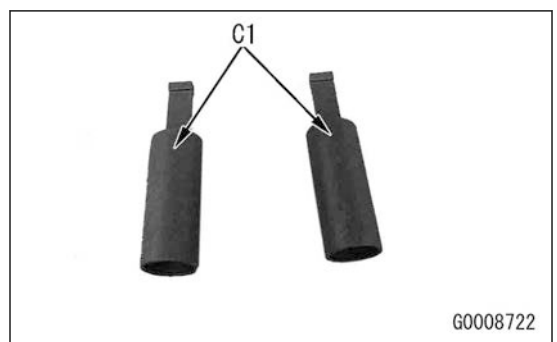
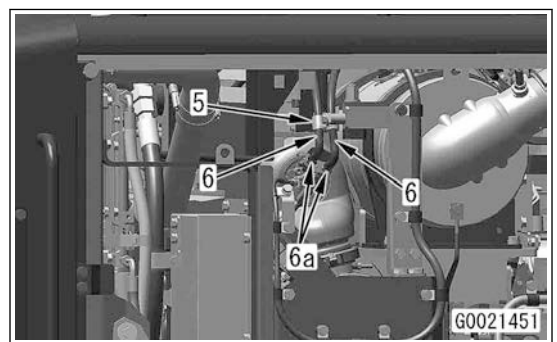

12. Tighten the bolts (70) (4 pieces) to the specified torque.

Tool: Ratchet handle, socket, torque wrench

Bolt (70): Width across flats 19 mm, M12

 Bolt (70): 98 to 123 Nm {10.0 to 12.5 kgm}

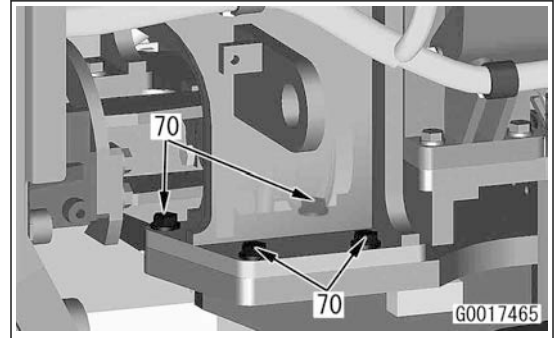

13. Tighten the bolts (69) (4 pieces) to the specified torque.

Tool: Ratchet handle, socket, torque wrench

Bolt (69): Width across flats 17 mm, M10

 Bolt (69): 59 to 74 Nm {6.0 to 7.5 kgm}

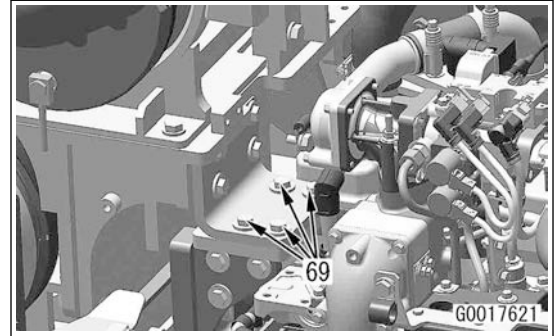

14. Tighten the bolts (68) (4 pieces) to the specified torque.

Tool: Ratchet handle, socket, torque wrench

Bolt (68): Width across flats 19 mm, M12

 Bolt (68): 98 to 123 Nm {10.0 to 12.5 kgm}

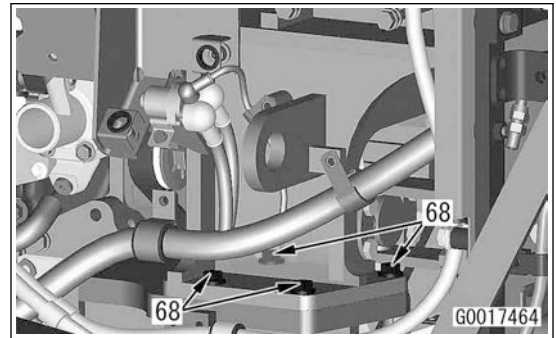

15. Tighten the bolts (67) (3 pieces) to the specified torque.

Tool: Ratchet handle, socket, torque wrench

Bolt (67): Width across flats 17 mm, M10

 Bolt (67): 59 to 74 Nm {6.0 to 7.5 kgm}

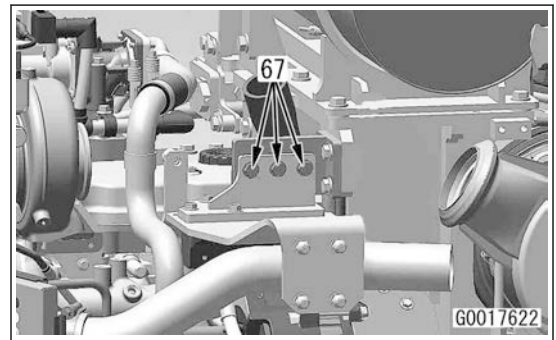

### Wiring, piping

16. Install the water drain tube (60) with the clamps (59) (2 pieces).

Tool: Ratchet handle, socket, torque wrench

Bolt for clamp (59): Width across flats 17 mm, M10

 Bolt for clamp (59): 59 to 74 Nm {6.0 to 7.5 kgm}

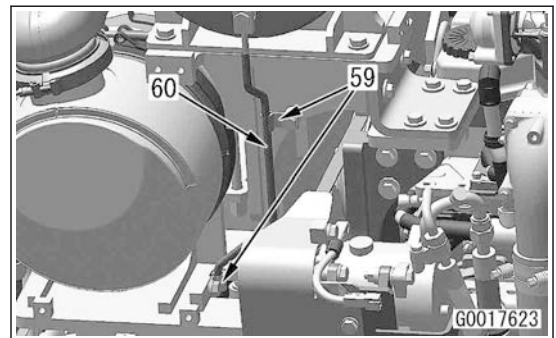

23. Insert the lock pin (1) to the stowage part (a), and install the pin (1a).

**REMARK**

Insert the lock pin (1) to the stowage part, and then install the pin (1a) securely.

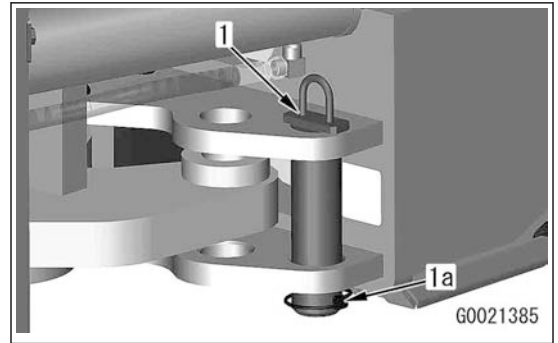

- 2) Disconnect the connector in the direction (d).

**REMARK**

If the connector lock (a) does not slide, insert a flat-head screwdriver into the part (b) to release the lock.

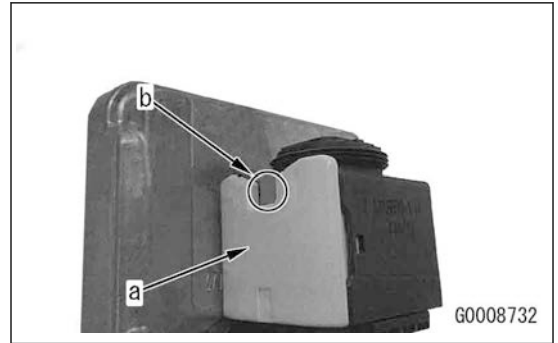
**DEF pump**

12. Remove the bolts (12a) (3 pieces), and remove the DEF pump (12).

Tool: Impact wrench, socket

Bolt (12a): Width across flats 13 mm, M8

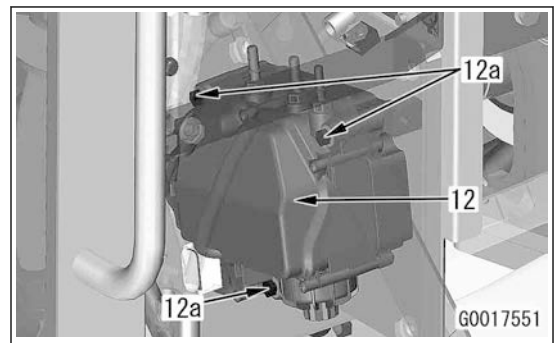
**How to Install DEF Pump****DEF pump**

1. Install the DEF pump (12) with the bolts (12a) (3 pieces).

Tool: Ratchet handle, socket, torque wrench

Bolt (12a): Width across flats 13 mm, M8

 Bolt (12a): 15.2 to 22.8 Nm {1.5 to 2.3 kgm}

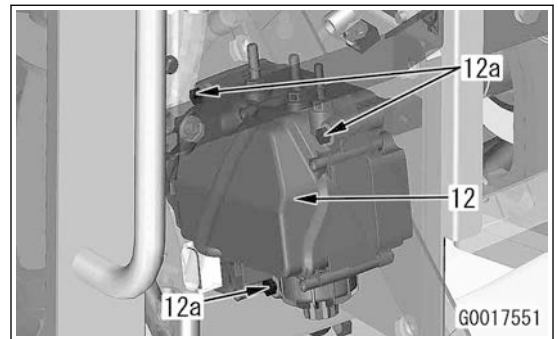
**Connector**

2. Connect the connector DSM (11) as follows.

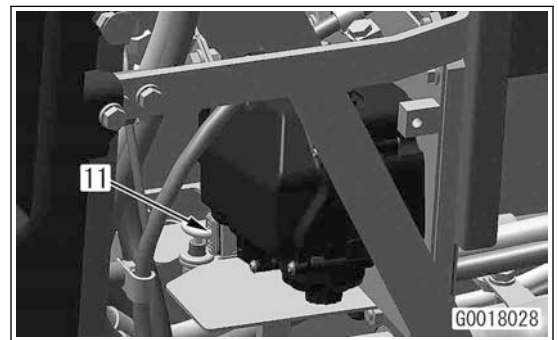

**Disc**

15. Install the disc (17).

 Sliding surface: Power train oil (TO10 or TO30)

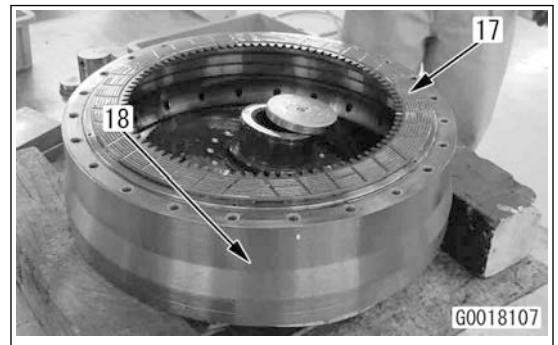
**Complete housing assembly**

16. Install the seal rings (15) (2 pieces) to the complete housing assembly (12).

**NOTICE**

**Install the seal ring (15) in the correct direction as shown in the figure.**

 Outer perimeter of seal ring: Grease (G0-LI or G2-LI)

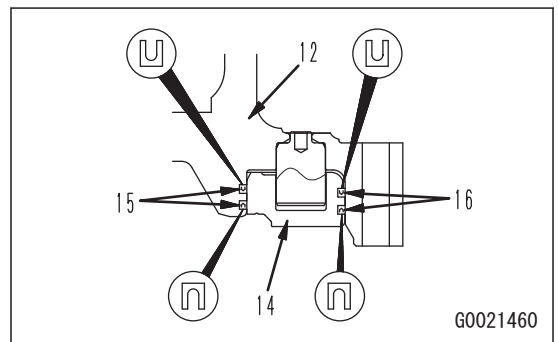
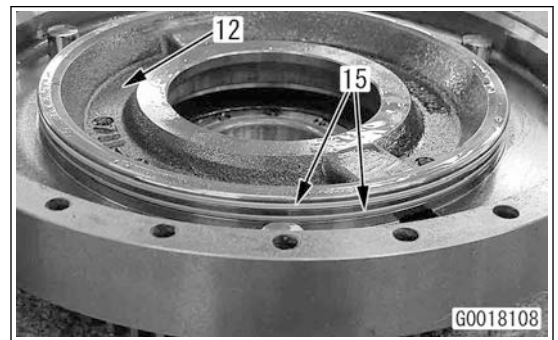

17. Install the seal rings (16) (2 pieces) to the piston (14).

**NOTICE**

**Install the seal ring (16) in the correct direction as shown in the figure.**

 Outer perimeter of seal ring: Grease (G0-LI or G2-LI)

18. Install the piston (14) to the complete housing assembly (12).

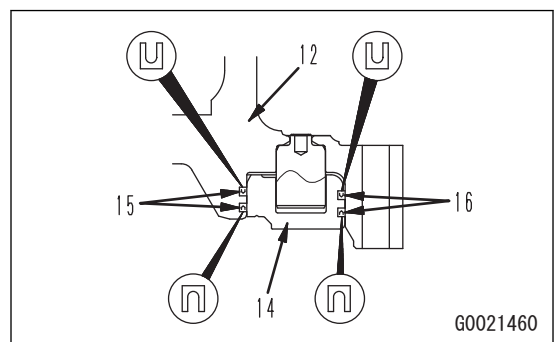
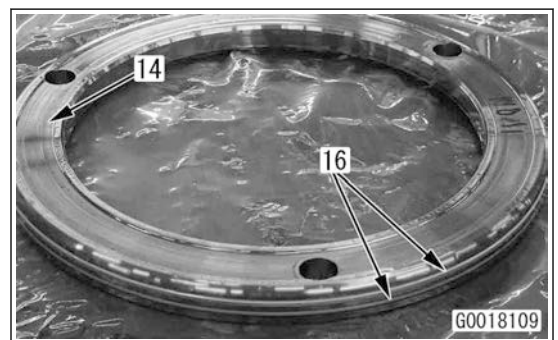

**Transmission top surface connector**

140. Install the clamps (24b) (3 pieces).

Tool: Ratchet handle, socket, torque wrench

Bolt for clamp (24b): Width across flats 17 mm, M10

 Bolt for clamp (24b): 59 to 74 Nm {6 to 7.5 kgm}

141. Install the bolts (24a) (2 pieces).

Tool: Ratchet handle, socket, torque wrench

Bolt (24a): Width across flats 17 mm, M10

 Bolt (24a): 59 to 74 Nm {6 to 7.5 kgm}

142. Connect the connectors that follow on the transmission top surface.

T39 (6): 1st clutch oil pressure

T27 (7): 1st solenoid

T37 (8): FH clutch oil pressure

T25 (9): FH solenoid

T38 (10): R clutch oil pressure

T26 (11): R solenoid

T40 (12): 2nd clutch oil pressure

T28 (13): 2nd solenoid

T41 (14): 3rd clutch oil pressure

T29 (15): 3rd solenoid

T42 (16): 4th clutch oil pressure

T30 (17): 4th solenoid

T31 (18): L/U solenoid

T36 (19): FL clutch oil pressure

T24 (20): FL solenoid

TG1 (21): Solenoid GND

Tool: Ratchet handle, socket, torque wrench

Bolt for TG1 (21): Width across flats 17 mm, M10

 Bolt for TG1 (21): 59 to 74 Nm {6 to 7.5 kgm}

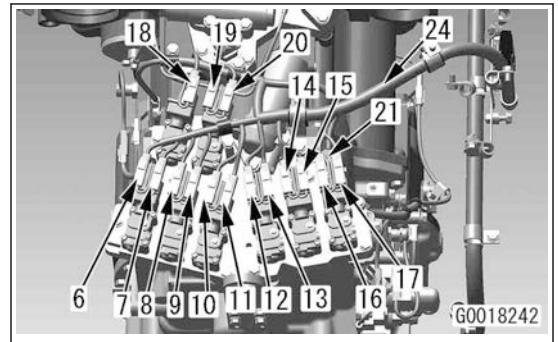
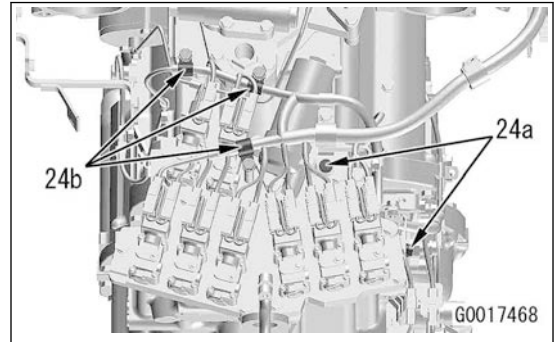
**Power train pump assembly**

143. Install the power train pump assembly (2) with the bolts (2a) (2 pieces).

Tool: Ratchet handle, socket, torque wrench

Bolt (2a): Width across flats 19 mm, M12

 Bolt (2a): 98 to 123 Nm {10 to 12.5 kgm}

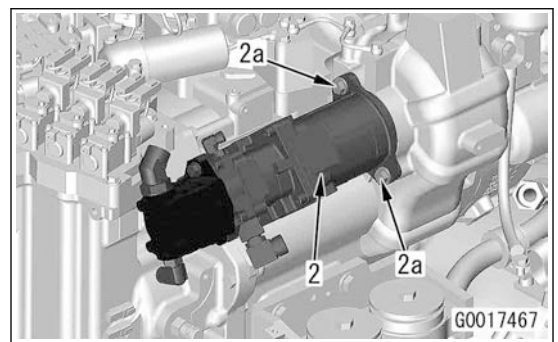

5. Align the shaft (80) with the spring pin hole (79a), and drive in the spring pin (79) to the carrier (78) with the pin (E) until they are aligned (j).

Tool: Pin (E)

6. Drive in the spring pin (79) (1 piece each) to the remaining shafts (80) (2 pieces) in the same procedure.

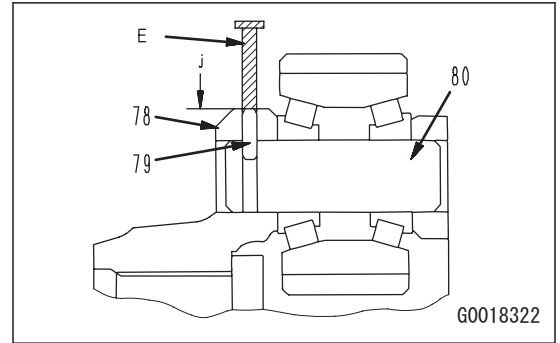

7. Hit the end surface of the shaft (80) and differential side of the pinion (81) lightly, push back the bearing (81a), and make sure that the pinion (81) rotates lightly.
8. Check the remaining pinions (81) (2 pieces) in the same procedure.
9. Assemble the planetary carrier assembly at the opposite side in the same procedure.

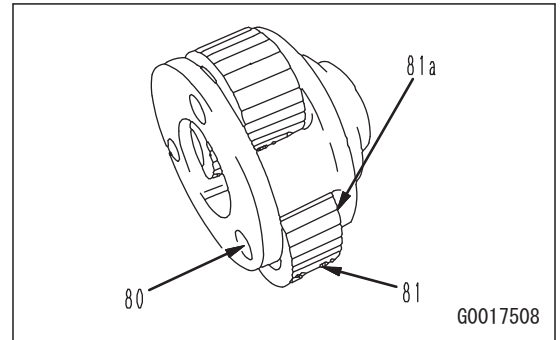

#### Side case assembly

10. Press fit the ring gear (14) to the side case (26), and drive in the pin (13).

#### REMARK

- Set the stamping groove (a) of the ring gear (14) as shown at the top of the figure, align the pin holes of the side case (26) and ring gear (14), and install it.
- Press fit the ring gear (14) horizontally not to be tilted.

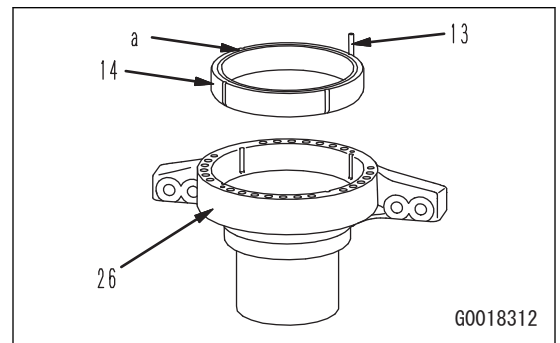

**REMARK**

- Install the plug on the hose to prevent entry of dirt or moisture.
- Move the disconnected hose to a safe place so that it does not interfere with the work.

Tool: Open-end wrench, plug (E), oil container

Hose (37): Width across flats 19 mm, #02 size

- 14) Loosen the sleeve nut, and disconnect the hoses (39) and (39a) from the joint (38).

**REMARK**

- Install the plug on the hose to prevent entry of dirt or moisture.
- Move the disconnected hose to a safe place so that it does not interfere with the work.

Tool: Open-end wrench, plug (F), oil container

Hose (39), (39a): Width across flats 22 mm, #03

- 15) Remove the clamp (38a).

Tool: Impact wrench, socket

Bolt for clamp (38a): Width across flats 17 mm, M10

- 16) Disconnect the connector FL9 (42).

- 17) Remove the bolt (41a), and remove the L.H. front working lamp (41).

Tool: Impact wrench, socket

Bolt (41a): Width across flats 19 mm, M12

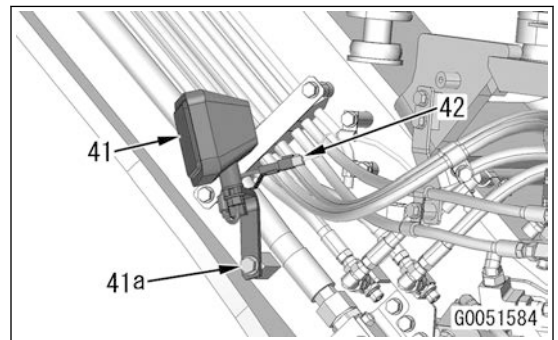
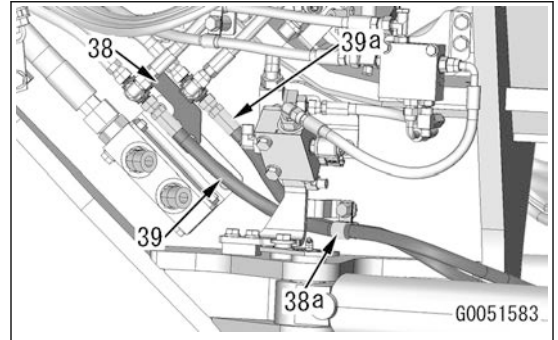

- 18) Remove the clamps (43) and (43a), and disconnect the hoses (40) (7 pieces).

**REMARK**

- Write down the color of the hose tape for each installation position.
- Move the disconnected hose to a safe place so that it does not interfere with the work.

Tool: Impact wrench, socket

Bolt for clamp (43), (43a): Width across flats 17 mm, M10

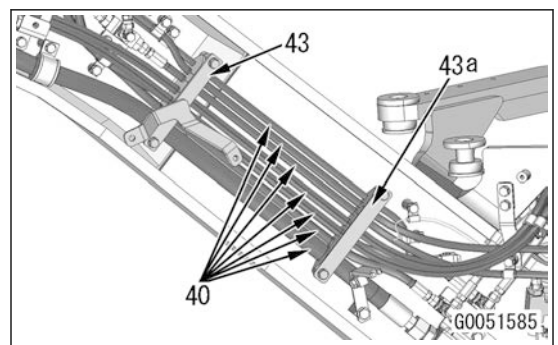

- 19) Remove the clamps (46) and (46a).

Tool: Impact wrench, socket

Bolt for clamp (46), (46a): Width across flats 19 mm, M12

- 20) Loosen the sleeve nut, and disconnect the control valve P1 port hose (47) and P2 port hose (48).

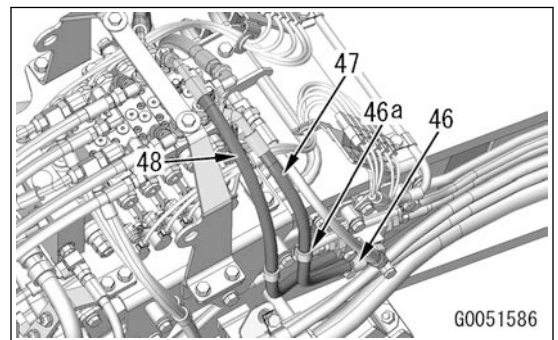

Tool: Ratchet handle, socket, torque wrench

Bolt for clamp (23a): Width across flats 17 mm, M10

 Bolt for clamp (23a): 59 to 74 Nm {6 to 7.5 kgm}

38. Connect the hose (23) to the hydraulic tank with the sleeve nut.

Tool: Ratchet handle, crowfoot wrench, torque wrench

Hose (23): Width across flats 19 mm, #02 size

 Hose (23): 34 to 54 Nm {3.5 to 5.5 kgm}

39. Install the bracket (22a) with the bolts (22) (4 pieces).

Tool: Ratchet handle, socket, torque wrench

Bolt (22): Width across flats 17 mm, M10

 Bolt (22): 59 to 74 Nm {6 to 7.5 kgm}

40. Install the clamp (21).

Tool: Ratchet handle, socket, torque wrench

Bolt for clamp (21): Width across flats 17 mm, M10

 Bolt for clamp (21): 59 to 74 Nm {6 to 7.5 kgm}

41. Connect the connector (20a) to the connector R20 (20), and install it to the clip.

42. Install the clamps (19) (4 pieces).

Tool: Ratchet handle, socket, torque wrench

Bolt for clamp (19): Width across flats 17 mm, M10

 Bolt for clamp (19): 59 to 74 Nm {6 to 7.5 kgm}

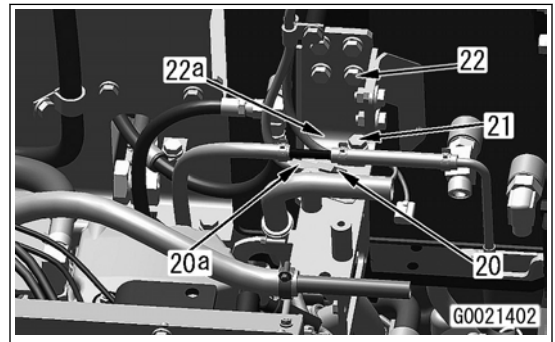

43. Connect the hose (18) to the hydraulic tank with the sleeve nut.

Tool: Ratchet handle, crowfoot wrench, torque wrench

Hose (18): Width across flats 27 mm, #04 size

 Hose (18): 84 to 132 Nm {8.5 to 13.5 kgm}

44. Install the clamp (18a).

Tool: Ratchet handle, socket, torque wrench

Bolt for clamp (18a): Width across flats 17 mm, M10

 Bolt for clamp (18a): 59 to 74 Nm {6 to 7.5 kgm}

45. Connect the hose (17) to the hydraulic tank with the sleeve nut.

Tool: Ratchet handle, crowfoot wrench, torque wrench

Hose (17): Width across flats 32 mm, #05 size

 Hose (17): 128 to 186 Nm {13.0 to 19.0 kgm}

46. Install the clamp (17a).

Tool: Ratchet handle, socket, torque wrench

Bolt for clamp (17a): Width across flats 17 mm, M10

 Bolt for clamp (17a): 59 to 74 Nm {6 to 7.5 kgm}

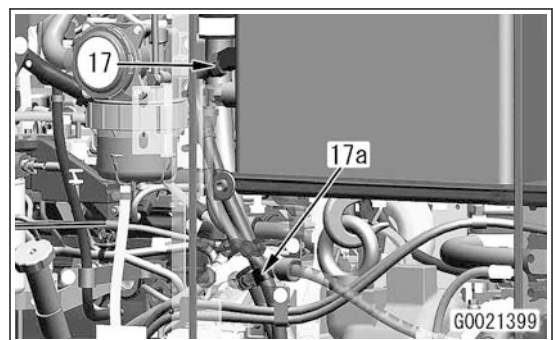
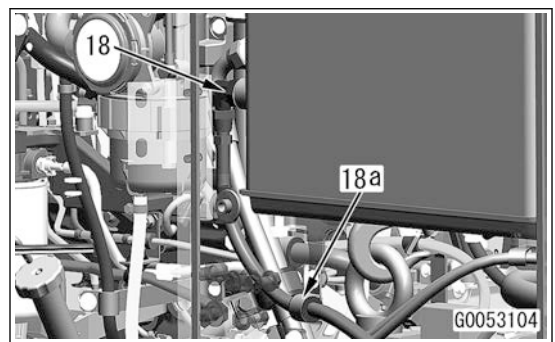
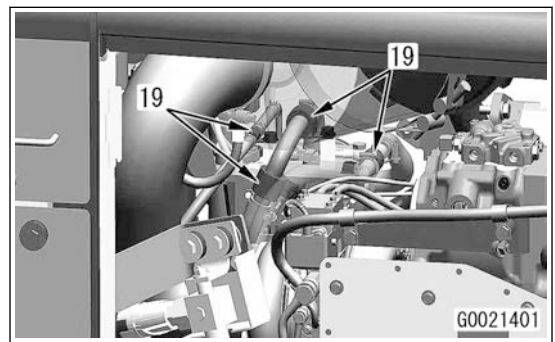

29. Remove the clamps (48a) (6 pieces) and bolt (48) of the L.H. horn assembly (48) and wiring harnesses (47) and (47a), and move them to a safe place so that they do not interfere with the work.

Tool: Impact wrench, socket

Bolt for clamp (48a), (48d): Width across flats 17 mm, M10

Bolt (48b): Width across flats 17 mm, M10

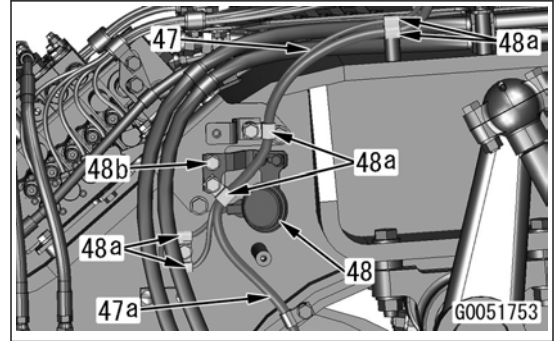

30. Remove the clamps (50a) (5 pieces) of the R.H. horn assembly (50) and wiring harness (49).

Tool: Impact wrench, socket

Bolt for clamp (50a): Width across flats 17 mm, M10

31. Remove the bolt (50b), and move the R.H. horn assembly (50) to a safety place so that it does not interfere with the work.

Tool: Impact wrench, socket

Bolt (50b): Width across flats 17 mm, M10

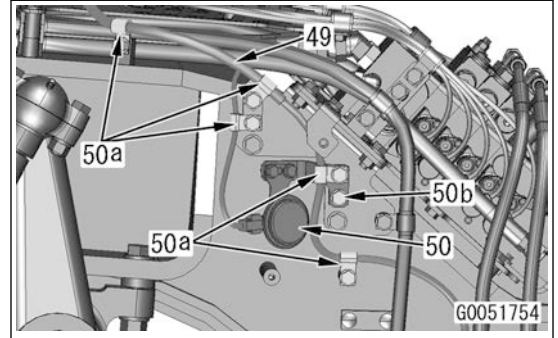

32. Disconnect the connectors that follow.

- (51a): FL48 (cable tie: red)
- (51b): FL47 (cable tie: blue)
- (51c): FL46 (cable tie: black)
- (51d): FL45 (cable tie: white)
- (51e): FL44 (cable tie: yellow)
- (51f): FL53 (cable tie: red)
- (51g): FL52 (cable tie: blue)
- (51h): FL51 (cable tie: black)
- (51j): FL50 (cable tie: white)
- (51k): FL49 (cable tie: yellow)

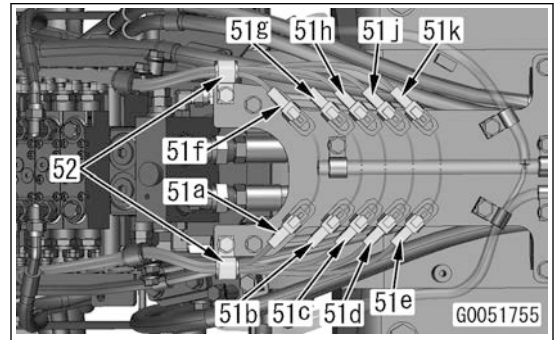

33. Remove the clamp (52).

Tool: Impact wrench, socket

Bolt for clamp (52): Width across flats 17 mm, M10

34. Remove the bolts (53) (4 pieces), and remove the bracket (54).

Tool: Impact wrench, socket

Bolt for clamp (53): Width across flats 17 mm, M10

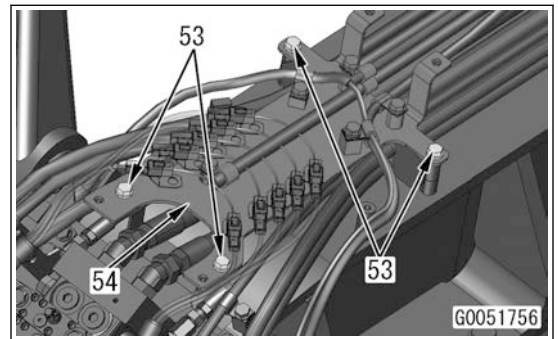

- Blade lift cylinder  
Install the dust seal (21), and press fit the bushing (20).  
Tool: Push tool

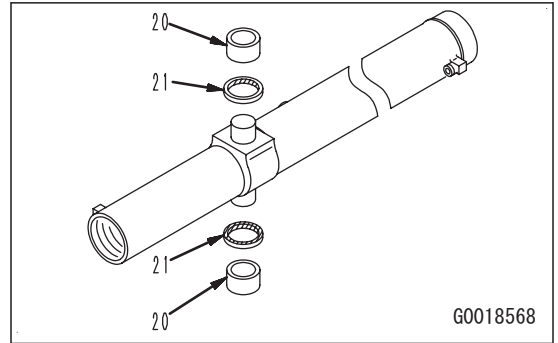

- Leaning cylinder, articulate cylinder, scarifier cylinder  
Press fit the bushing (23), and install the dust seal (22).

**REMARK**

The figure shows the leaning cylinder as an example.

Tool: Push tool

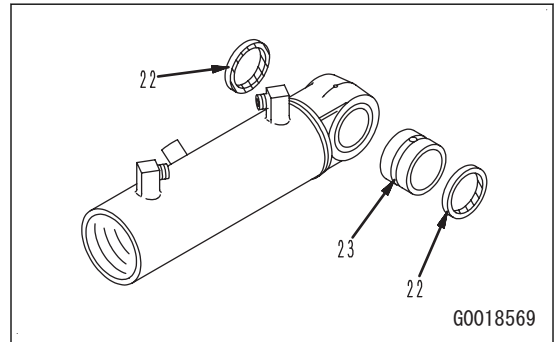

- Steering cylinder, power tilt cylinder  
Press fit the bushing (25), and install the snap ring (24).

**REMARK**

The figure shows the steering cylinder as an example.

Tool: Snap ring pliers, push tool

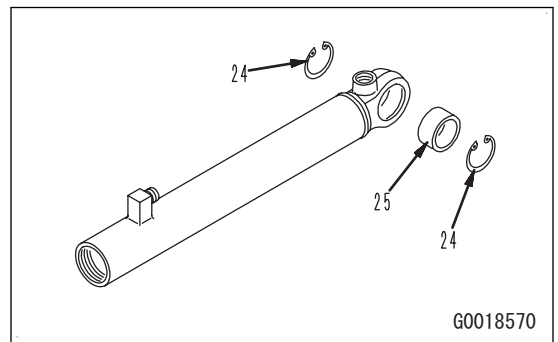

**Piston rod**

2. Install the bushing as follows.

- Leaning cylinder, articulate cylinder, scarifier cylinder, ripper cylinder  
Press fit the bushing (17), and install the dust seal (16).

**REMARK**

The figure shows the leaning cylinder as an example.

Tool: Push tool

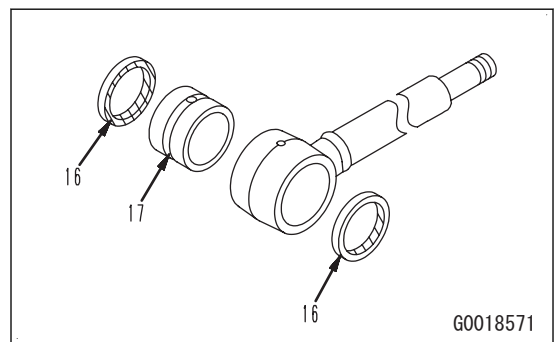

- Power tilt cylinder  
Press fit the bushing (19), and install the snap ring (18).  
Tool: Snap ring pliers, push tool

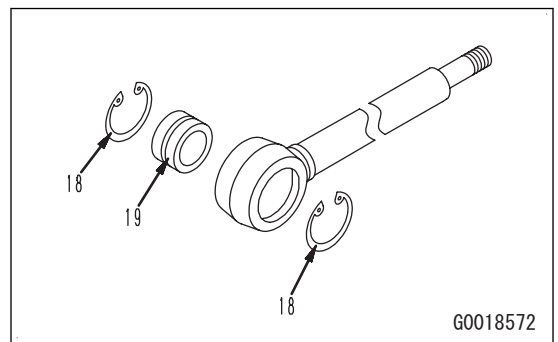

**REMARK**

Install the additional dam rubber (6a) for the R.H. window glass (1).

Installation position of additional dam rubber for R.H. window glass

(f): 50 mm

(g): 90 mm

(h): 250 mm

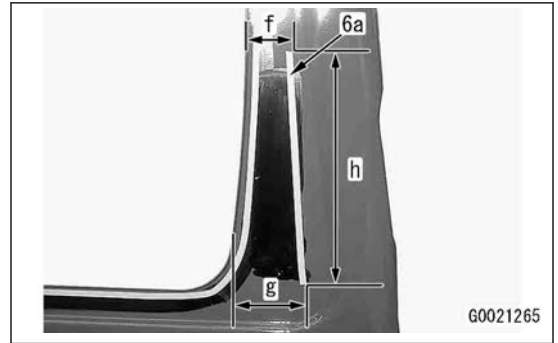

- 2) Install the dam rubber (6) for the L.H. side glass (2) to the position shown in the figure.



- 3) Install the dam rubber (6) for the door lower side glass (3) to the position shown in the figure.

**REMARK**

Install the additional dam rubber (6a) for the door lower side glass (3).

Installation position of additional dam rubber for door lower side glass

(j): 50 mm

(k): 90 mm

(m): 200 mm

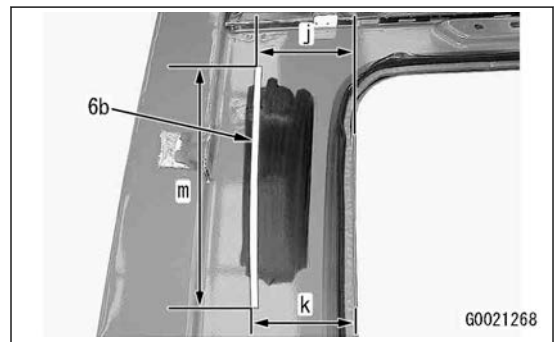
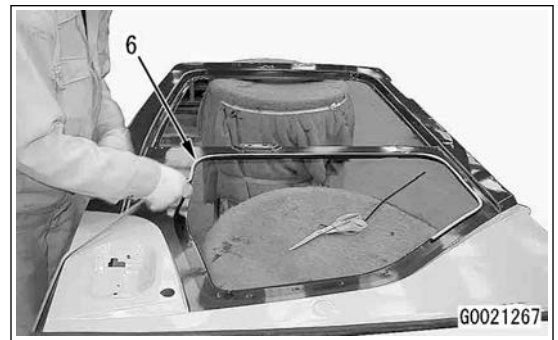

- 4) Install the dam rubber (6) for the front window glass (4) to the position shown in the figure.

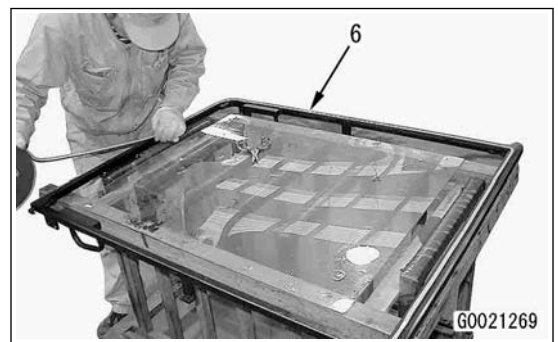

8. Remove the bolts (10) (4 pieces), and remove the suspension (11).

**REMARK**

As it is not possible to use a crane inside of the operator cab, be sure to remove the suspension (11) with 2 persons.

Tool: Impact wrench, socket

Bolt (10): Width across flats 13 mm, M08

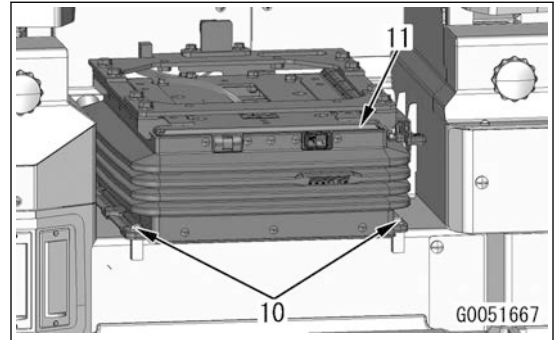
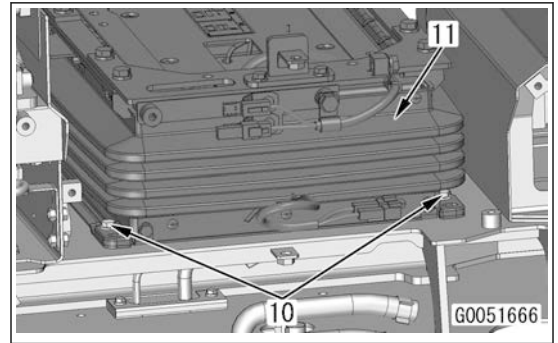

Suspension (11): 40 kg

**How to Install Operator Seat****Suspension**

1. Install the suspension (11) with the bolts (10) (4 pieces).

**REMARK**

As it is not possible to use a crane inside of the operator cab, be sure to install the suspension (11) with 2 persons.

Tool: Ratchet handle, socket, torque wrench

Bolt (10): Width across flats 13 mm, M08



Suspension (11): 40 kg



Bolt (10): 27 to 34 Nm {2.8 to 3.5 kgm}

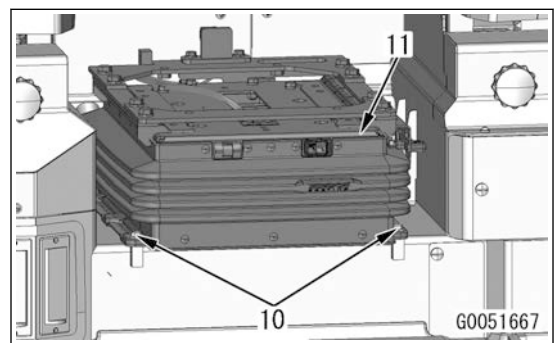
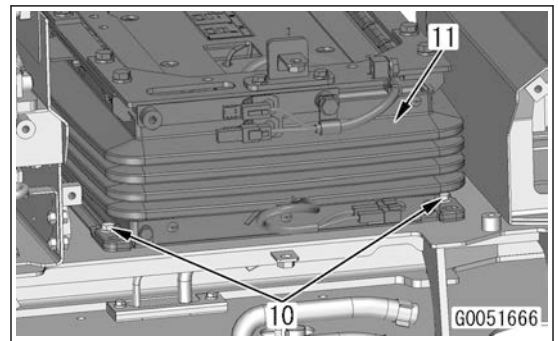

- Remove the bolts (6) (2 pieces), and lift the machine monitor assembly (7) for a small distance.

Tool: Impact wrench, socket

Bolt (6): Width across flats 13 mm, M8

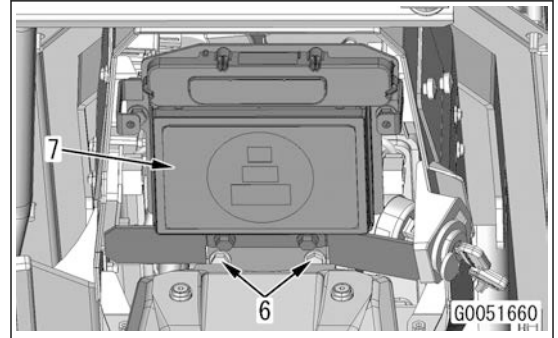

- Disconnect the connectors MDM2 (8) and MOM1 (9) at the back side of the machine monitor assembly (7), and remove the machine monitor assembly (7).

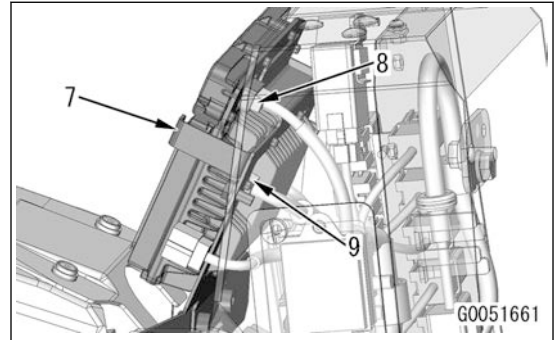

## How to Install Machine Monitor Assembly



### Machine monitor assembly

- Connect the connectors MDM2 (8) and MOM1 (9) at the back side of the machine monitor assembly (7).

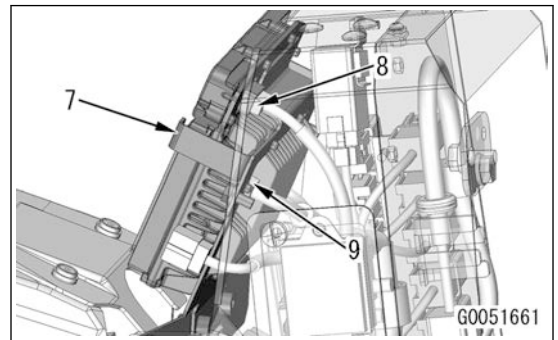

- Install the machine monitor assembly (7) with the bolts (6) (2 pieces).

Tool: Ratchet handle, socket, torque wrench

Bolt (6): Width across flats 13 mm, M8

 Bolt (6): 27 to 34 Nm {2.8 to 3.5 kgm}

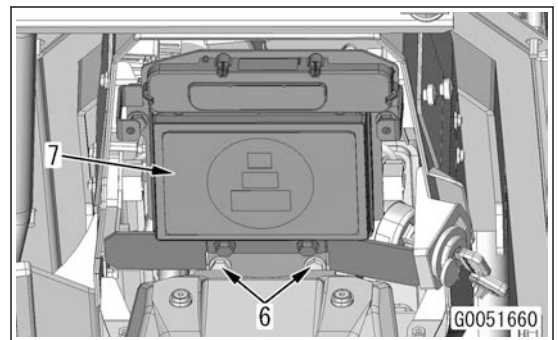

## Remove and Install KOMTRAX Terminal Assembly

### Standard tool list

The listed parts are for reference only. You can use the part that is not listed if it is applicable.

No.	Part name	Part No.	Specifications	Q'ty	Remarks
1	Hexagonal wrench	Commercially available	4 mm	1	
2	Socket	Commercially available	10 mm	1	
3	Ratchet handle	Commercially available		1	
4	Torque wrench	Commercially available	3 to 15 Nm	1	

**⚠ Stop the machine on level ground, lower the work equipment to the ground and lock it with the work equipment lock switch, and then apply the brake with the parking brake switch.**

**⚠ Stop the engine, and chock the tires.**

**⚠ Set the battery disconnect switch to the OFF position, and remove the key. (For details, see Testing and Adjusting, "Handle Battery Disconnect Switch".)**

### How to Remove KOMTRAX Terminal Assembly



#### KOMTRAX terminal assembly

1. Remove the pin (1a), and remove the lock pin (1) from the stowage part (a).

#### REMARK

The pin (1a) is not used during this work.

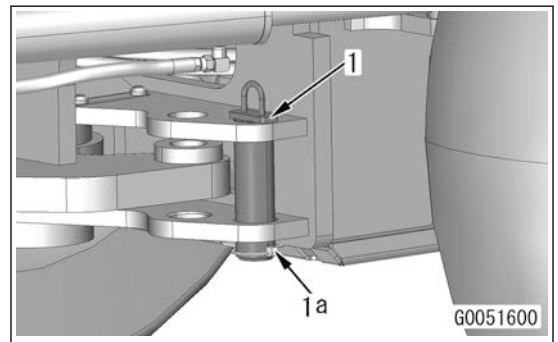

Maintenance Standard for FL, R Clutch

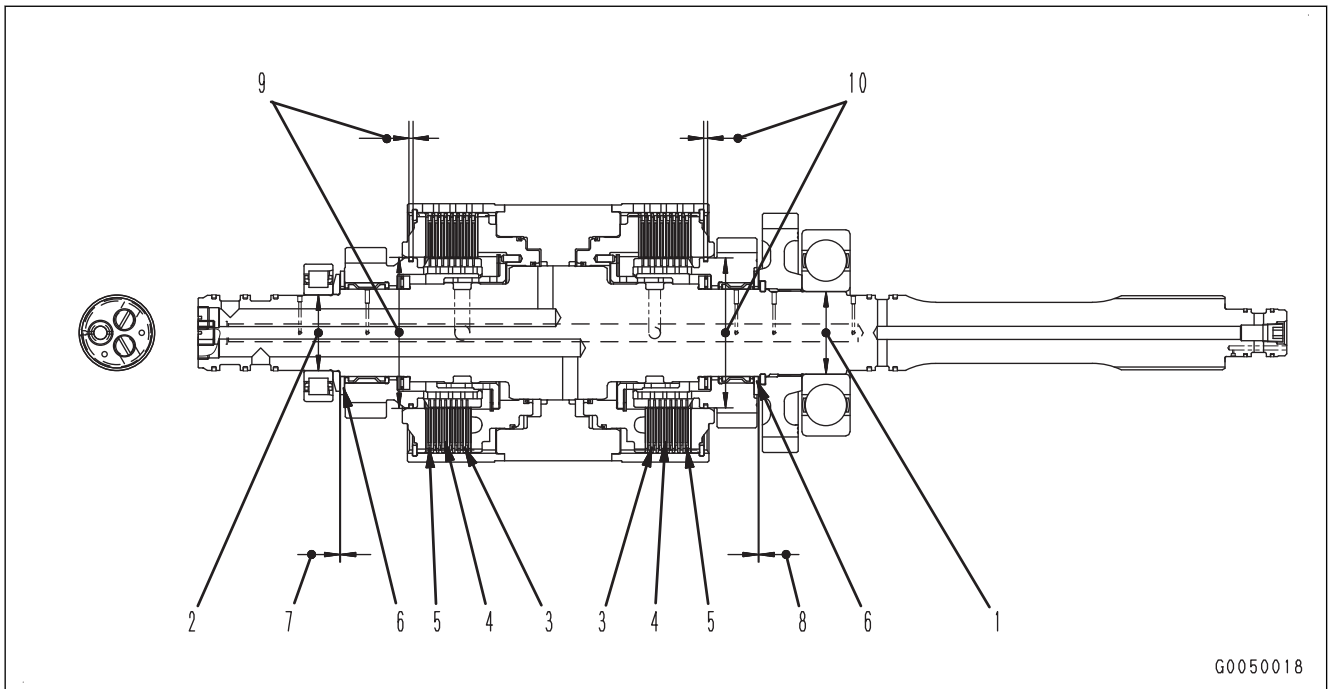

G0050018

Unit mm

No.	Item	Judgment criteria				Remedy	
		Standard dimensions	Tolerance		Standard clearance		Allowable clearance
	Shaft		Hole				
1	Clearance between input shaft and bearing and input shaft (rear)	60	+0.030 +0.011	0 -0.015	-0.045 to -0.011	-	
2	Clearance between input shaft and bearing and input shaft (front)	55	+0.034 +0.021	0 -0.015	-0.049 to -0.021	-	
3	Clutch plate	Standard dimensions	Tolerance		Repair limit		
		Thickness	1.7	± 0.05		1.53	
		Distortion	-	0.05		0.15	
4	Clutch disc	Thickness	2.2	± 0.08		1.82	
		Distortion	-	0.1		0.25	
5	Load of wave spring (test height: 2.2 mm)	1010 N {103 kg}	± 101 N {± 10.3 kg}		859 N {87.6 kg}		
6	Thickness of thrust washer	3	± 0.1		2.7		
7	Clearance of R clutch gear	0.11 to 0.99					
8	Clearance of FL clutch gear	0.06 to 1.19					

Replace

## Work Equipment

### Maintenance Standard for Solenoid Valve (Work Equipment Lock)

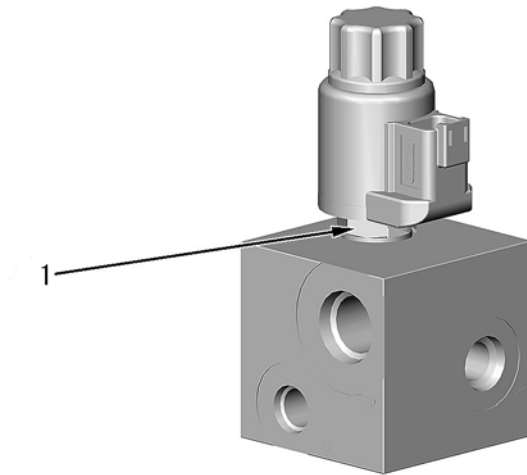

G0054842

No.	Item	Judgment criteria	Remedy
1	Tightening torque of the solenoid	25 to 30 Nm {2.55 to 3.06 kgm}	Retighten

- Symptom: If the hot water to the heater core cannot be shut off, the temperature can rise even when set to COOL MAX. Or, if the hot water is shut off constantly, the temperature does not rise when the heater is used.
- See "Troubleshooting for Hot Water Cut Valve".

## Connect Service Tool

- ⚠ Stop the machine on a level ground. Lower the work equipment to the ground.
- ⚠ Set the parking brake switch to the ON position. Lock the work equipment lock switch. Set the steering control lever enable switch to the DISABLE position. Stop the engine.
- ⚠ Make sure that the system operating lamp is not lit. Turn the battery disconnect switch to the OFF position. Remove the key.

Code	Part No.	Part name
-	799-703-1200	Service tool kit

### Service Tool Kit

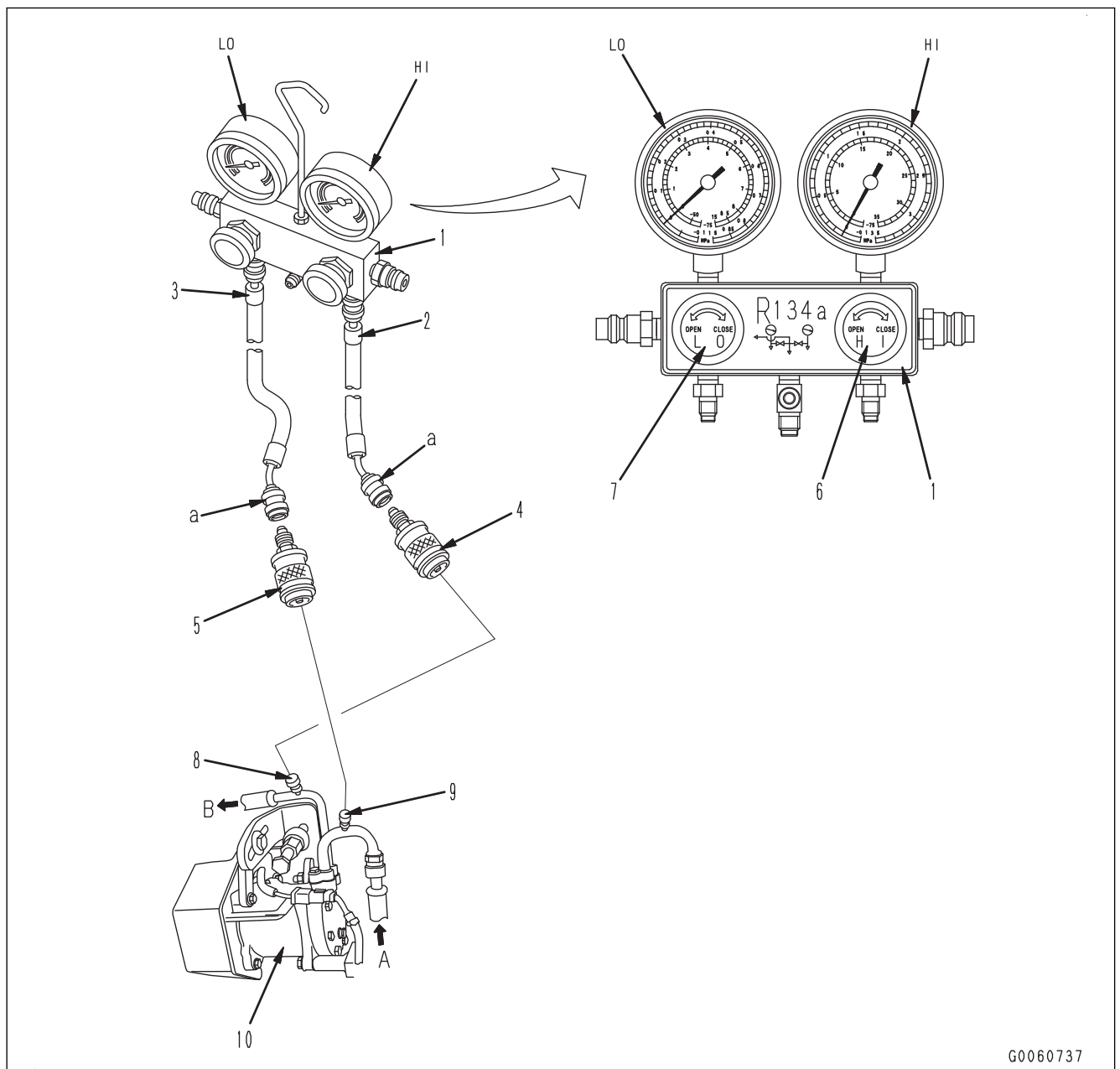

G0060737

A: From operator's cab

B: To condenser

1: Gauge manifold

4: Large diameter quick joint (for high-pressure line)

2: High pressure side charging hose (red)

5: Small diameter quick joint (for low-pressure line)

3: Low pressure charging hose (blue)

6: High pressure valve

# Electrical Circuit Diagram of Machine (Applicable Machine: 65217 to 65481) (3/7)

## REMARK

This figure includes the equipment and device that are not available as optional items in some areas.

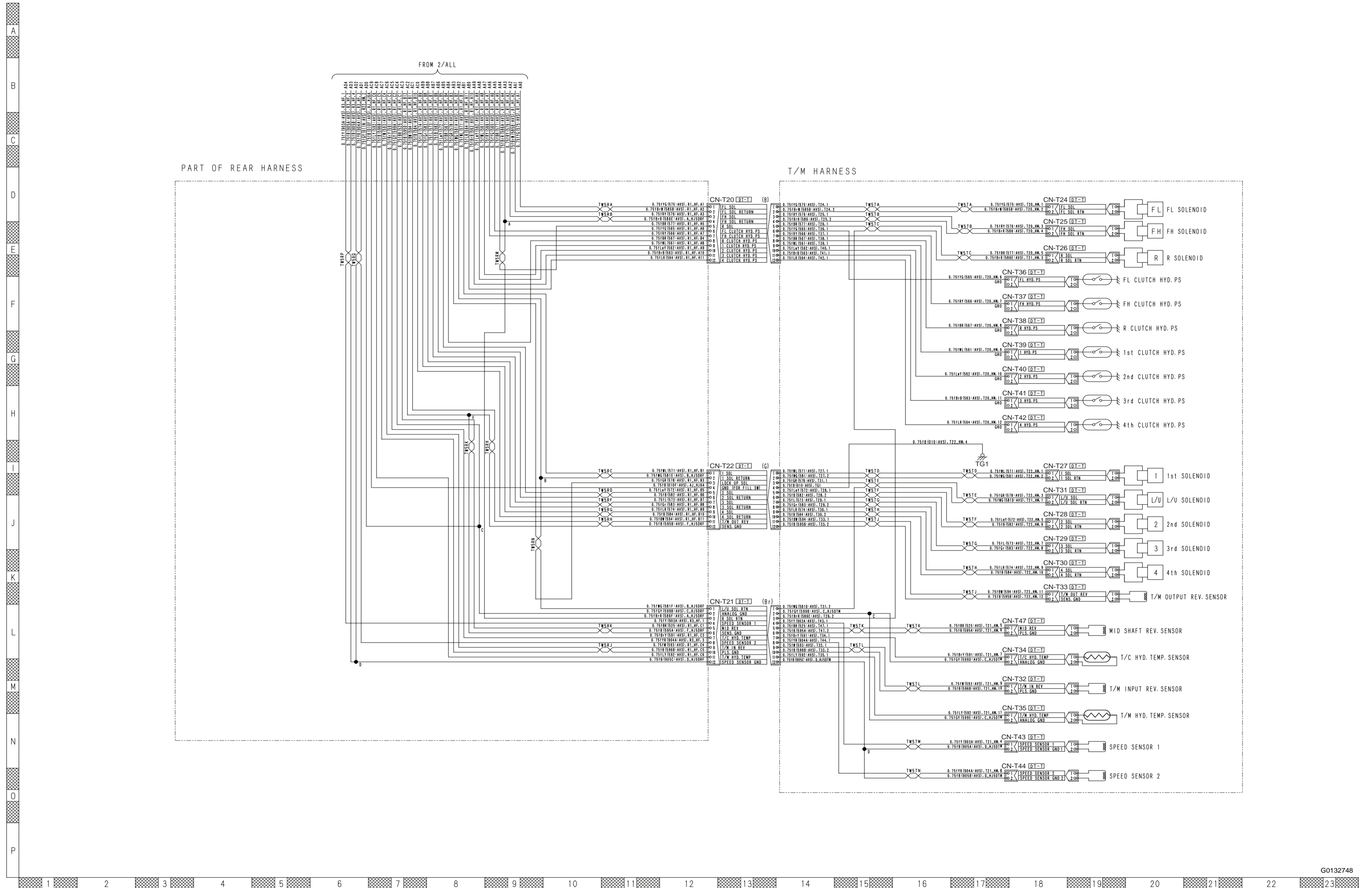

CLICK HERE TO **DOWNLOAD** THE COMPLETE MANUAL

- Thank you very much for reading the preview of the manual.
- You can download the complete manual from: [www.heydownloads.com](http://www.heydownloads.com) by clicking the link below



- Please note: If there is no response to CLICKING the link, please download this PDF first and then click on it.

CLICK HERE TO **DOWNLOAD** THE COMPLETE MANUAL