

# SHOP MANUAL

**KOMATSU**

# **GD600-3 SERIES**

MACHINE MODEL	SERIAL No.
<b>GD600R-3</b>	<b>14001 and up</b>
<b>GD650R-3</b>	<b>24001 and up</b>
<b>GD605R-3</b>	<b>34001 and up</b>
<b>GD655R-3</b>	<b>44001 and up</b>
<b>GD605A-3</b>	<b>54001 and up</b>
<b>GD655A-3</b>	<b>64001 and up</b>

CLICK HERE TO **DOWNLOAD** THE COMPLETE MANUAL

- Thank you very much for reading the preview of the manual.
- You can download the complete manual from: [www.heydownloads.com](http://www.heydownloads.com) by clicking the link below





- Please note: If there is no response to CLICKING the link, please download this PDF first and then click on it.

CLICK HERE TO **DOWNLOAD** THE COMPLETE MANUAL

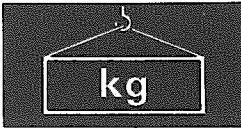
# HOISTING INSTRUCTIONS



 Heavy parts (25 kg or more) must be lifted with a hoist etc. In the **Disassembly and Assembly** section, every part weighing 25 kg or more is indicated clearly with the symbol 

1. If a part cannot be smoothly removed from the machine by hoisting, the following checks should be made:

- Check for removal of all bolts fastening the part to the relative parts.
- Check for existence of another part causing interference with the part to be removed.

## 2. Wire ropes

1) Use adequate ropes depending on the weight of parts to be hoisted, referring to the table below:

Wire ropes (Standard "Z" or "S" twist ropes without galvanizing)	
Rope diameter (mm)	Allowable load (tons)
10	1.0
11.2	1.4
12.5	1.6
14	2.2
16	2.8
18	3.6
20	4.4
22.4	5.6
30	10.0
40	18.0
50	28.0
60	40.0

The allowable load value is estimated to be one-sixth or one-seventh of the breaking strength of the rope used.

2) Sling wire ropes from the middle portion of the hook.

Slinging near the edge of the hook may cause the rope to slip off the hook during hoisting, and a serious accident can result. Hooks have maximum strength at the middle portion.

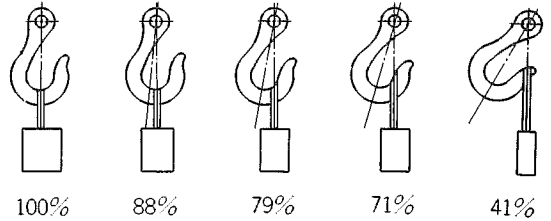

FS0064

3) Do not sling a heavy load with one rope alone, but sling with two or more ropes symmetrically wound on to the load.

 Slings with one rope may cause turning of the load during hoisting, untwisting of the rope, or slipping of the rope from its original winding position on the load, which can result in a dangerous accident.

4) Do not sling a heavy load with ropes forming a wide hanging angle from the hook.

When hoisting a load with two or more ropes, the force subjected to each rope will increase with the hanging angles. The table below shows the variation of allowable load (kg) when hoisting is made with two ropes, each of which is allowed to sling up to 1000 kg vertically, at various hanging angles.

When two ropes sling a load vertically, up to 2000 kg of total weight can be suspended. This weight becomes 1000 kg when two ropes make a 120° hanging angle. On the other hand, two ropes are subjected to an excessive force as large as 4000 kg if they sling a 2000 kg load at a lifting angle of 150°.

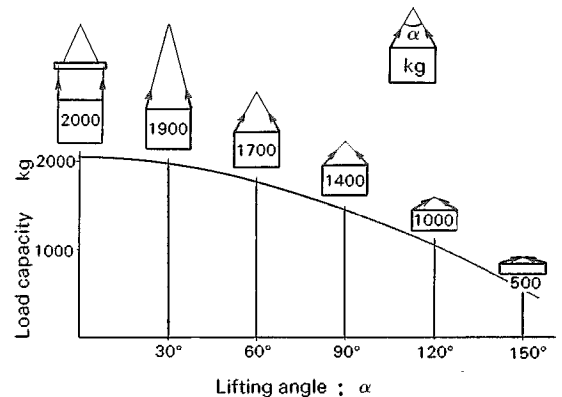

FS0065

MODEL		GD600R-3	GD650R-3	GD605R-3	GD655R-3
SERIAL NUMBERS		14001 and up	24001 and up	34001 and up	44001 and up
Wheels	Tire	13.00 – 24 – 10PR			
	Rim	8.00TG x 24 SDC			
Work equipment and Hydraulic control	Control valve	R.H. 3-spool, L.H. 4-spool with safety valve			
	Max. oil pressure	175 kg/cm <sup>2</sup>			
	Oil pump discharge	2 x 39ℓ/min.			
	Oil motor discharge	78ℓ/min.			
	Blade length x height x thickness	3710 mm x 655 mm x 19 mm	4010 mm x 655 mm x 19 mm	3710 mm x 655 mm x 19 mm	4010 mm x 655 mm x 19 mm
	Model	6D125-1			
Engine	No. of cylinders – bore x stroke (mm)	6 – 125 x 150			
	Piston displacement (cc)	11040			
	Flywheel horsepower (HP/rpm)	145/1800	165/1800	145/1800	165/1800
	Maximum torque (kgm/rpm)	73/1100	77/1100	73/1100	77/1100
	Fuel oil	Diesel fuel ASTM D975 No. 2 or No. 1			
	Fuel pump	Bosch PE-NB type			
	Governor	Bosch RSV Centrifugal, all-speed type			
	Alternator	24V 25A			
	Starting motor	24V 7.5 kW			
	Battery	12V, 150Ah x 2			

# ENGINE MOUNTING

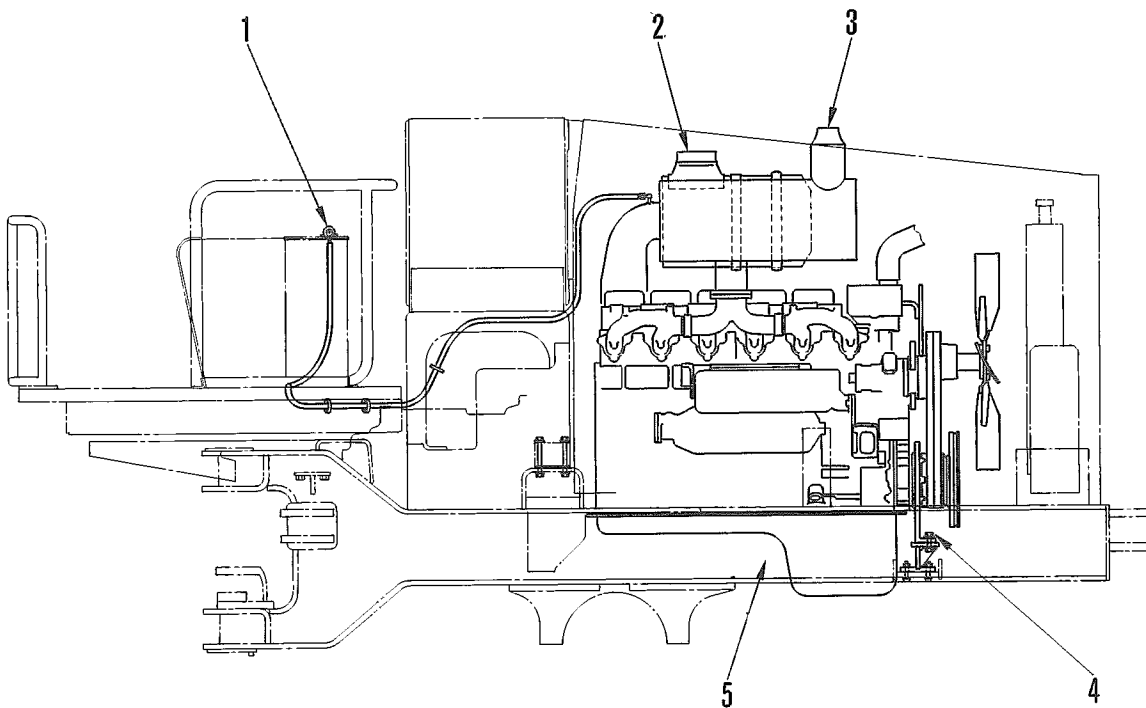
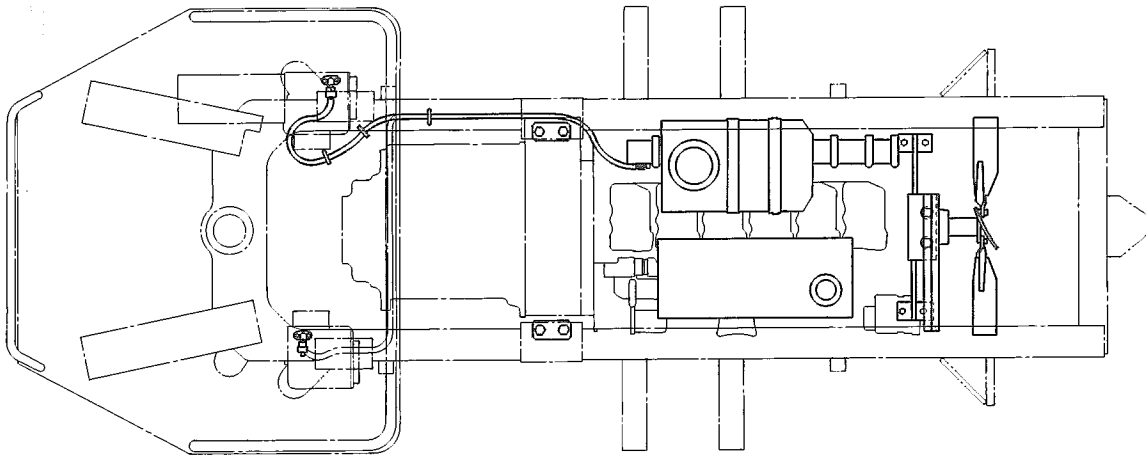

F23B03003

- 1. Dust indicator
- 2. Air cleaner
- 3. Muffler
- 4. Mounting bolt
- 5. Main frame

## MEASURING BLOW-BY

### Special tool

	Part number	Part name	Q'ty
A	799-201-1502	Blow-by checker	1

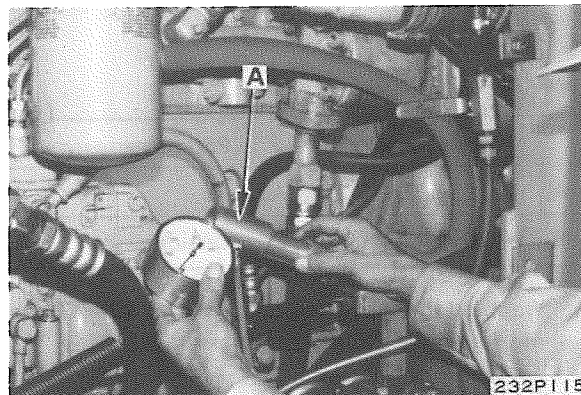

### 1. Measuring blow-by

Connect tool A to breather hose.

- ★ Check that the oil filler and dipstick are properly sealed.

### 2. Precautions when measuring blow-by

- ★ Measure blow-by with the engine properly warmed up (oil temperature: 60°C) and running at rated output.
- When measuring in the field, a similar value will be obtained at stall speed.
- If it is impossible to run the engine at rated output or at stall speed, measure at high idling. The blow-by value obtained at high idling will be about 80% of the value at rated output.
- ★ Blow-by varies greatly according to the condition of the machine, so if the value obtained is considered abnormal, check for factors related to defective blow-by. These factors include excessive oil consumption, defective exhaust gas color, deterioration and early discoloration of oil.

## REMOVAL OF WATER PUMP ASSEMBLY

GD600R, GD650R-3

1. Loosen drain valve (1) and drain cooling water.  
★ If the coolant contains antifreeze, dispose of it correctly.
2. Remove L.H. engine side cover.
3. Disconnect tubes (2), (3) and (4) of vacuum pump.
4. Remove vacuum pump assembly (5).
5. Remove tube (6).
6. Disconnect radiator outlet hose (7).
7. Disconnect bypass tube (8) at hose.
8. Remove 3 mounting bolts (9), then remove water pump assembly (10).

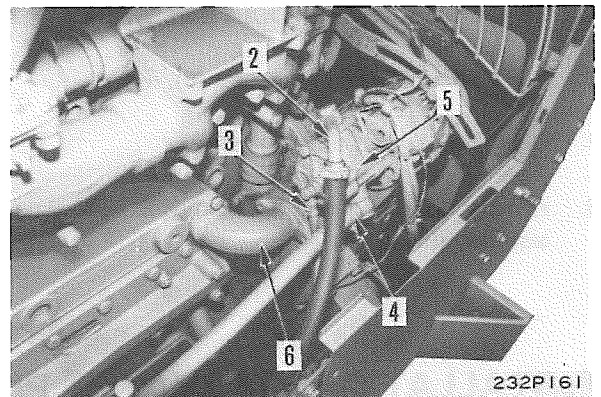
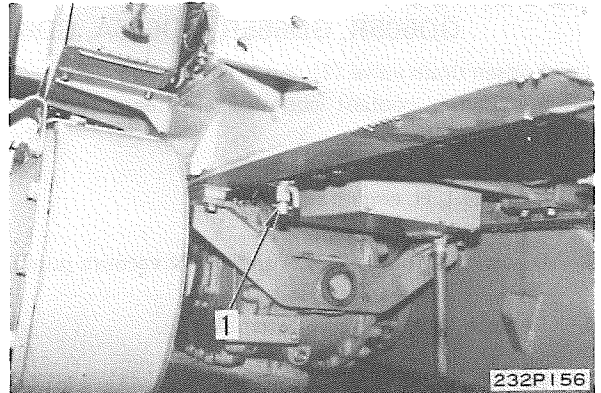

## INSTALLATION OF WATER PUMP ASSEMBLY

GD600R, GD650R-3

1. Fit gasket and install water pump assembly (10), then tighten 3 mounting bolts (9).
  2. Connect bypass tube (8) at hose, then secure with hose clamp.
  3. Connect radiator outlet hose (7).
  4. Fit gasket and install tube (6).
  5. Fit gasket and install vacuum pump assembly (5).
  6. Fit gaskets and connect tubes (4), (3) and (2) of vacuum pump.
  7. Install L.H. engine side cover.
  8. Tighten drain valve (1) and add water through water filler to the specified level.
- ★ Run the engine to circulate the water through the system.  
Then check the water level again.

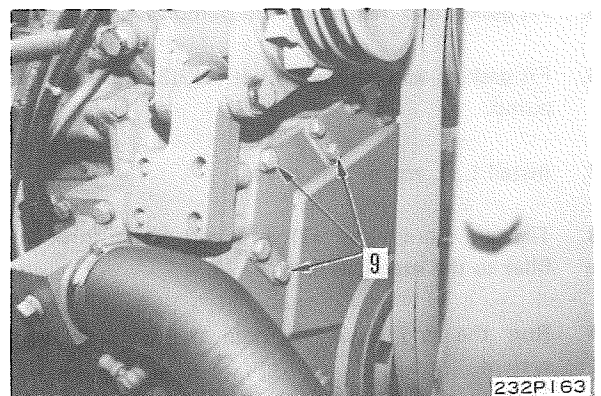
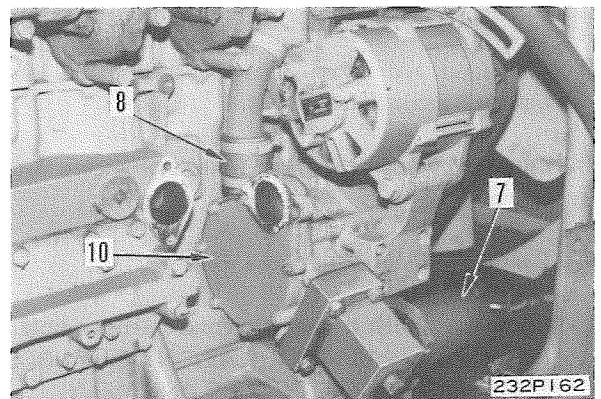

**18. Rocker lever**

Remove mounting bolts (20), then remove rocker lever (21).

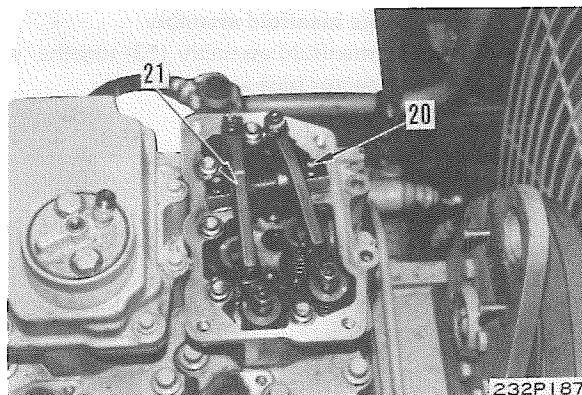
**19. Rocker lever housing**

Remove rocker lever housing (22).

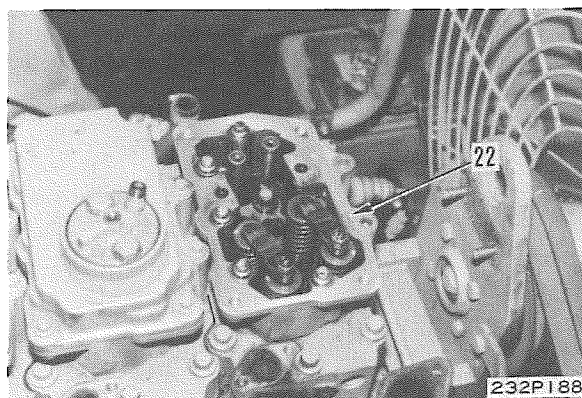
**20. Push rod**

Remove push rod (23).

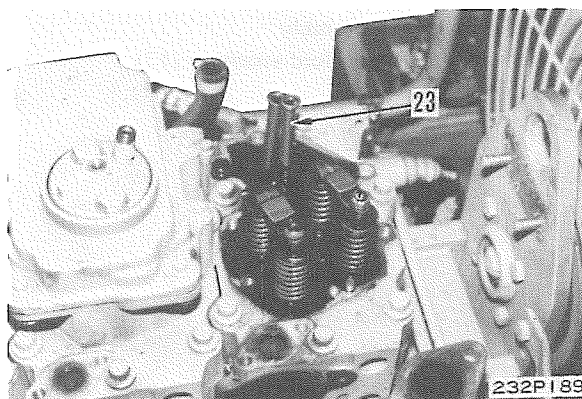
**21. Crosshead**

Remove crosshead (24).

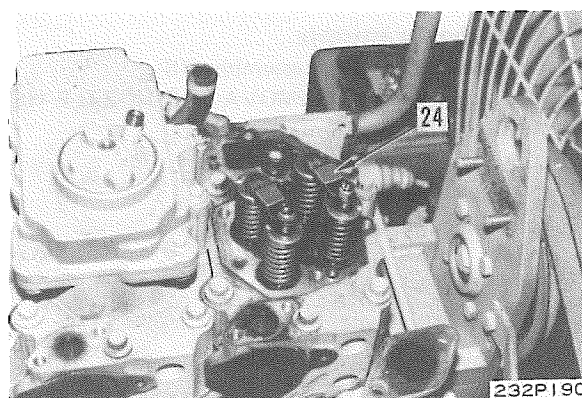

## INSTALLATION OF RADIATOR ASSEMBLY

1. Raise radiator assembly (9) and install.

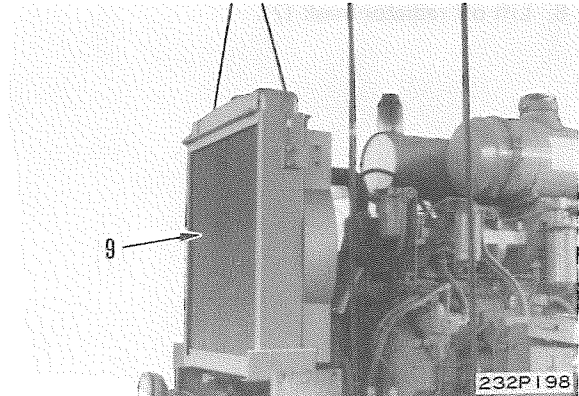

2. Connect radiator drain hose (8).

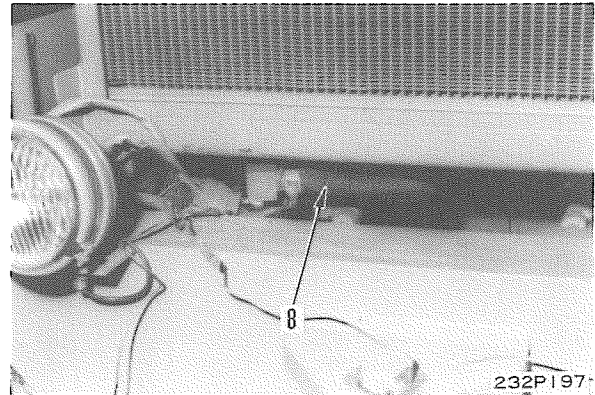

3. Raise radiator mask (7) and install.

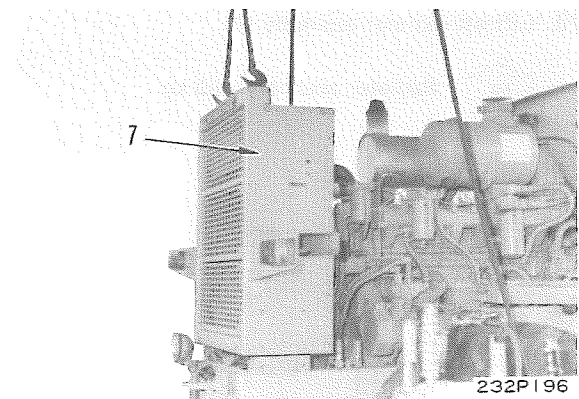

4. Connect radiator outlet hose (6).

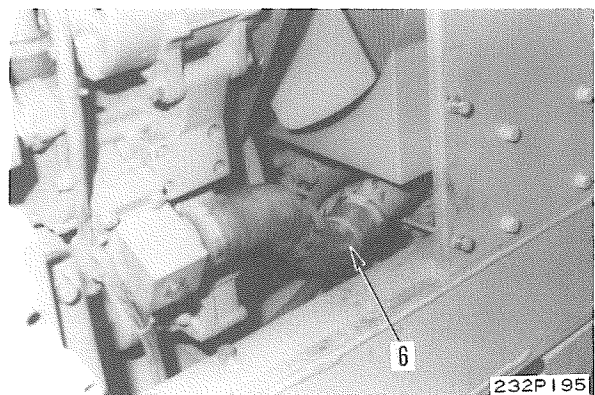

**13. Transmission piping**

- 1) Disconnect hose (22) between flywheel housing and transmission.
- 2) Disconnect hose (23) between main clutch and transmission.

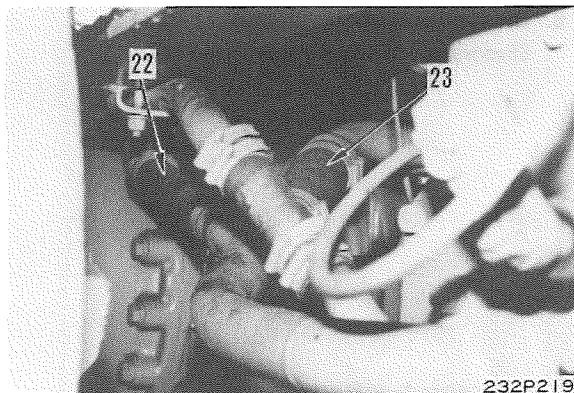

- 3) Disconnect transmission lubrication hose (24) at booster end.

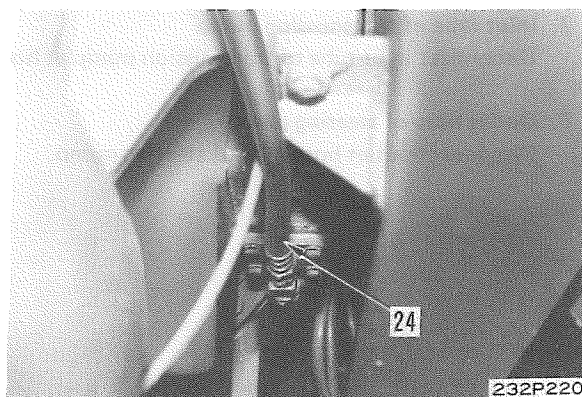
**14. Vacuum hose**

Disconnect hose (25) between vacuum pump and vacuum tank.

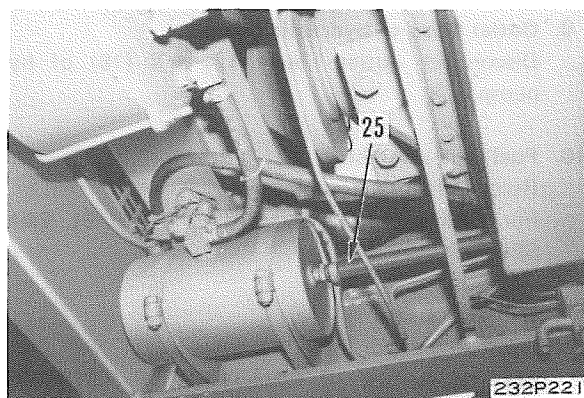
**15. Universal joint**

Remove universal joint (26).

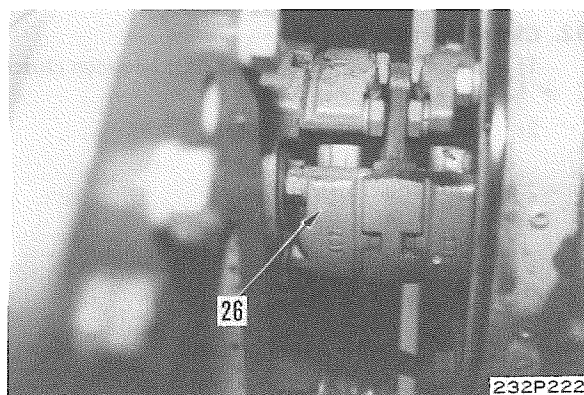

- 3) Disconnect wire (8) of water temperature gauge.
- 4) Disconnect wire (9) of alternator.

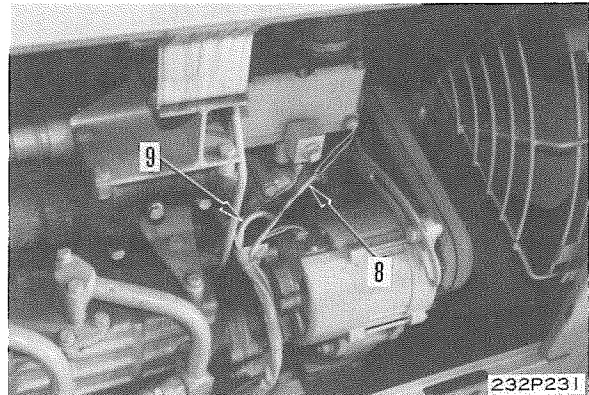

- 5) Disconnect wire (10) of oil pressure gauge.

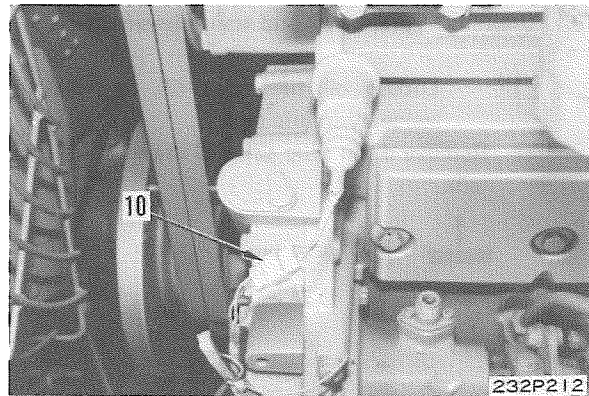

- 6) Disconnect wire (11) of electric heater.

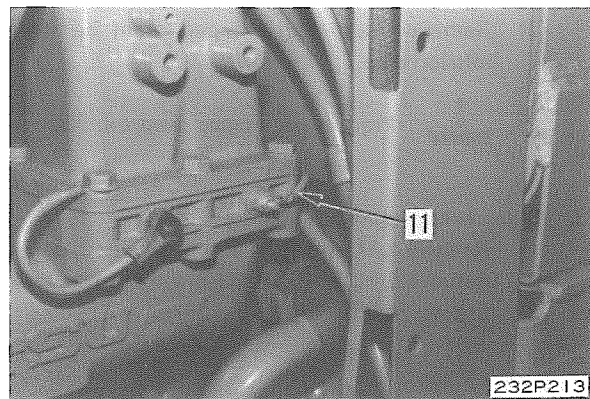

5. **Fuel control cable**  
Remove spring (12), then disconnect fuel control cable (13).

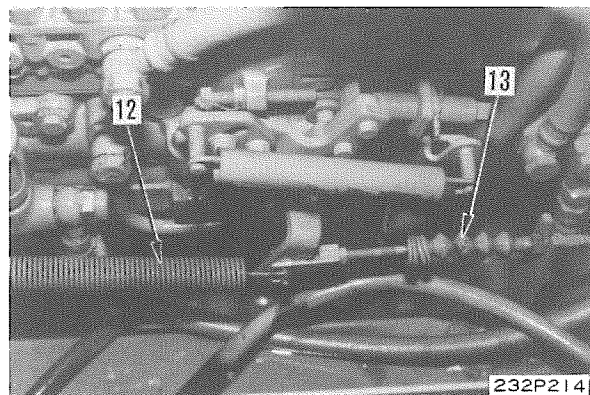

**15. Fuel control cable**

Connect fuel control cable (13), secure with locknut, then install spring (12).

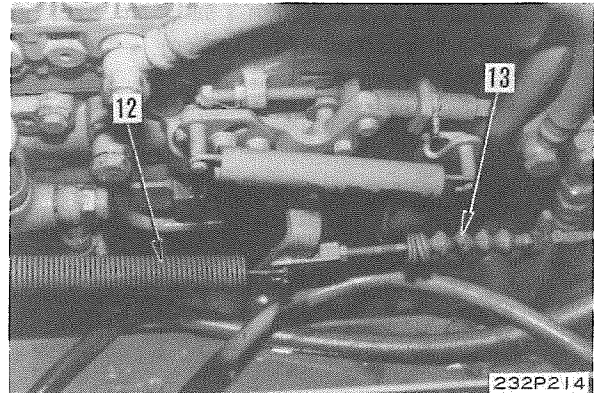
**16. Wiring**

1) Connect wire (11) of electric heater.

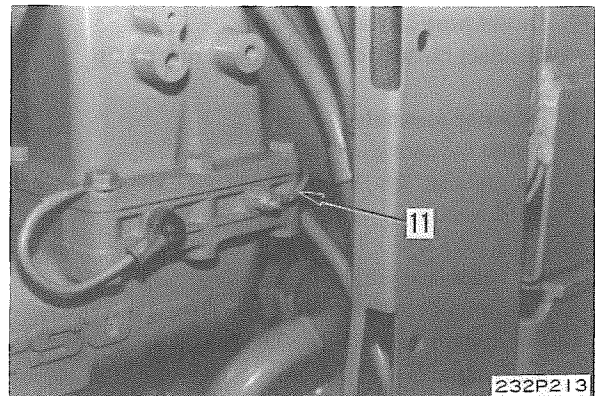

2) Connect wire (10) of oil pressure gauge.

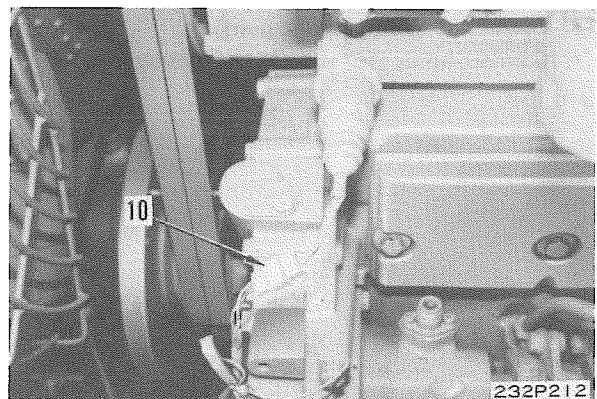

3) Connect wire (9) of alternator.

4) Connect wire (8) of water temperature gauge.

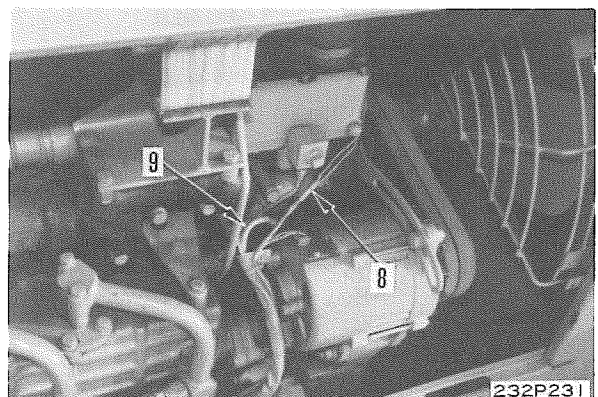

GD605R-3  
 GD655R-3  
 GD605A-3  
 GD655A-3

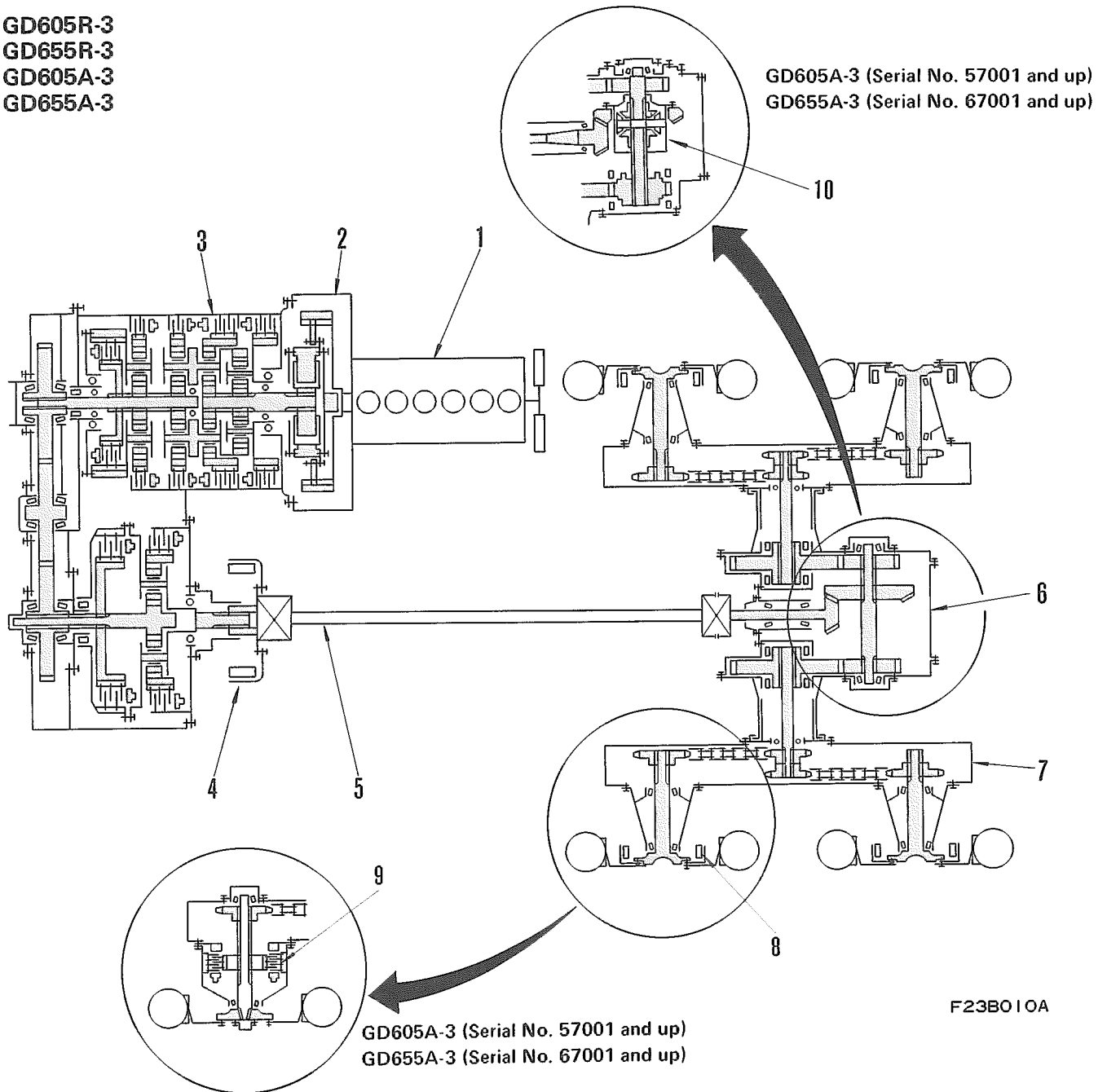

F23B010A

GD605A-3 (Serial No. 57001 and up)  
 GD655A-3 (Serial No. 67001 and up)

1. Engine
2. Damper
3. HYDROSHIFT transmission
4. Parking brake
5. Drive shaft
6. Final drive
7. Tandem drive
8. Brake lining
9. Disc brake
10. Differential (Lock/Unlock) (OP)

TRANSMISSION CONTROL LEVER

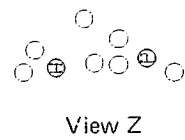
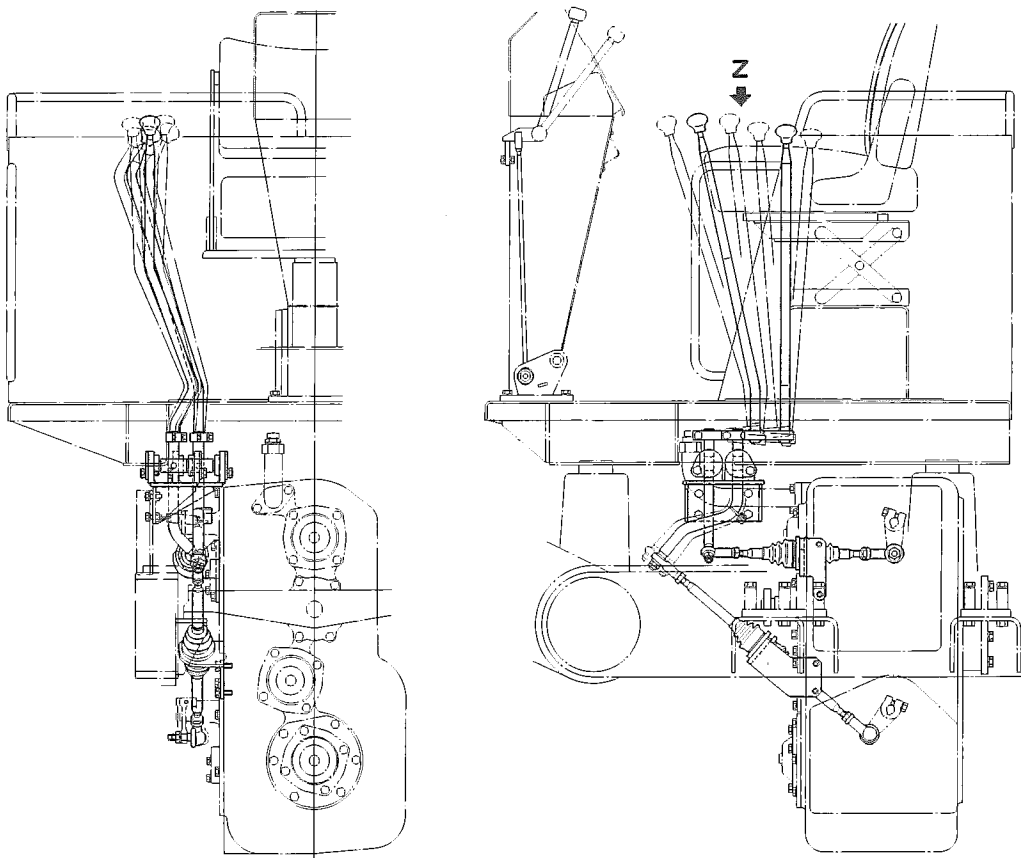

View Z

F23B03008

## REVERSE 1st GEAR (R, 1st, L)

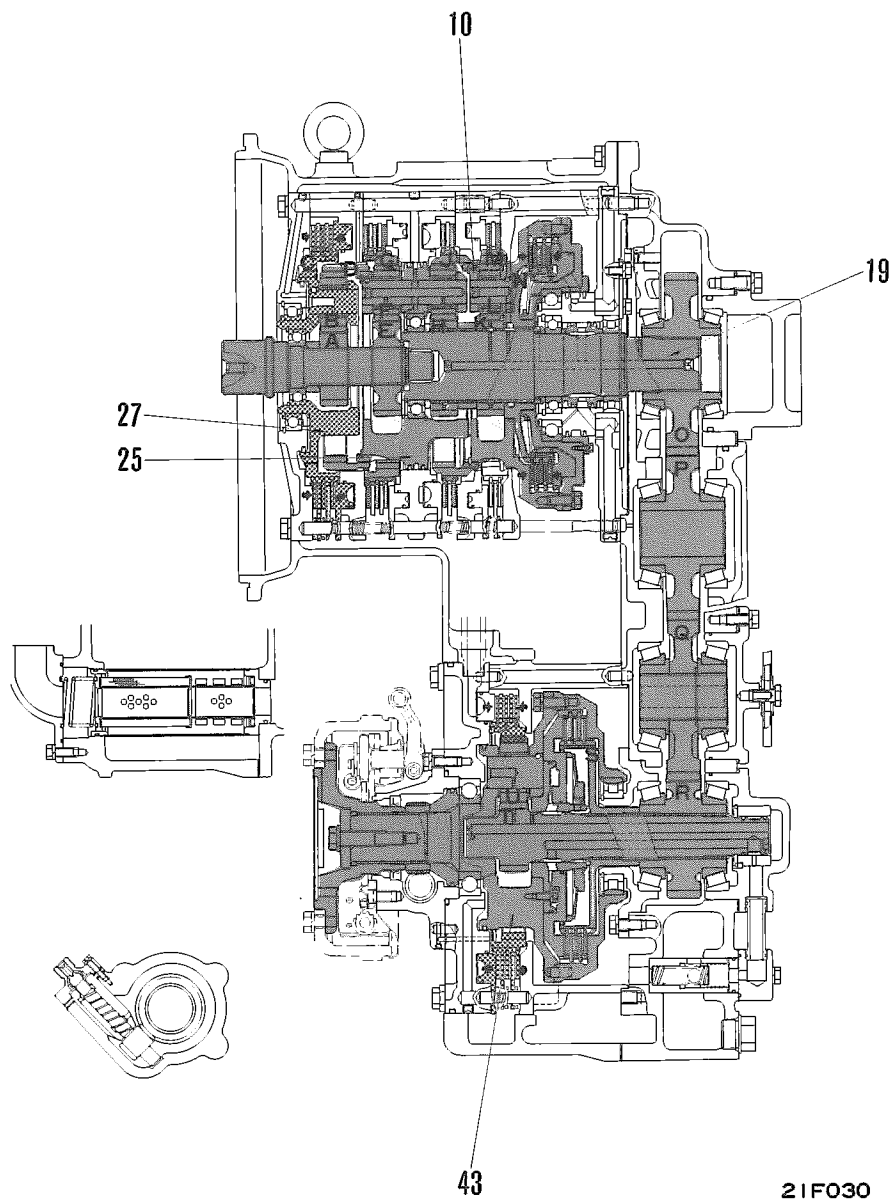

Power is transmitted from R sun gear A to R planetary pinion B.

Because R ring gear C is fixed by R clutch, R carrier (20) is also fixed.

Because of this R planetary pinion revolves on its axis. R ring gear D revolves in the opposite direction to R sun gear. At this time power is transmitted to revolve F carrier (25) in the opposite direction to the input shaft revolution because it is one with R ring gear.

Transmission of power after this is the same as with Forward 1st gear.

# HYDROSHIFT TRANSMISSION LUBRICATING CIRCUIT

GD605R, GD655R, GD605A, GD655A-3

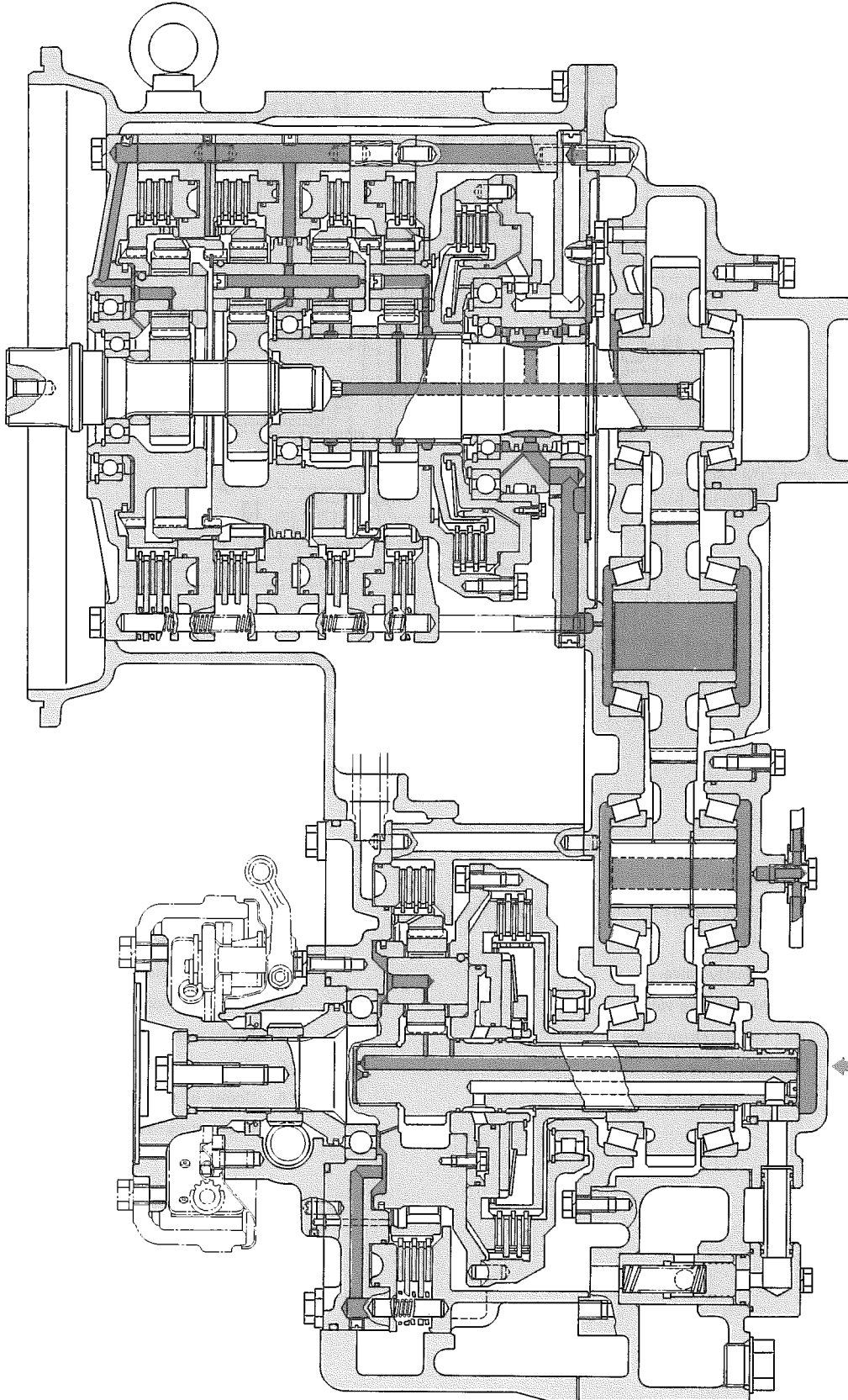

21F047

# DIFFERENTIAL LOCK AND UNLOCK PIPING

GD605A-3 (Serial No. 57001 and up)  
 GD655A-3 (Serial No. 67001 and up)

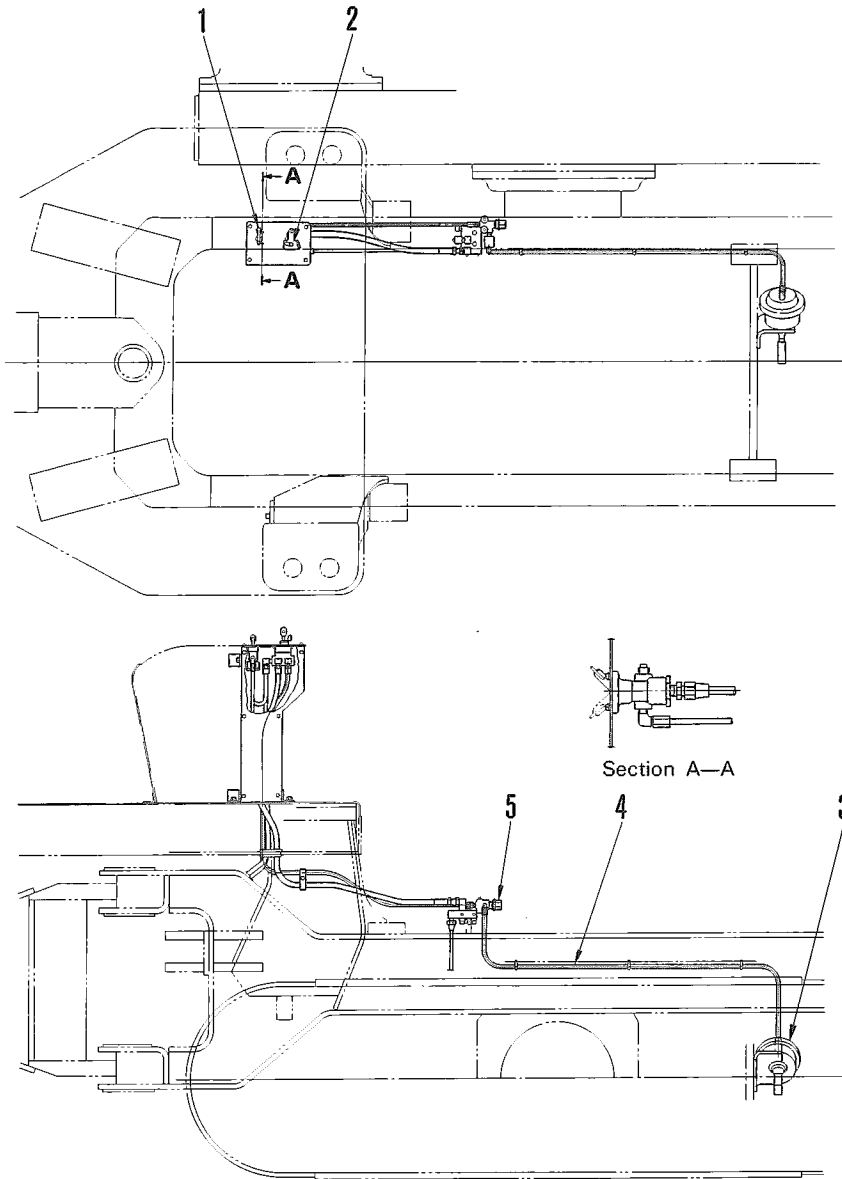

F23B106

- 1. Lever (Differential control)
- 2. Lever (Lifter lock release)
- 3. Hydromaster
- 4. Air tube
- 5. Air regulator valve

**TESTING TRANSMISSION OIL PRESSURE (LUBRICANT PRESSURE)**

1. Remove measuring plug (4) and attach hydraulic tester A (25 kg/cm<sup>2</sup>).
2. Run engine, measure transmission lubricating oil pressure.

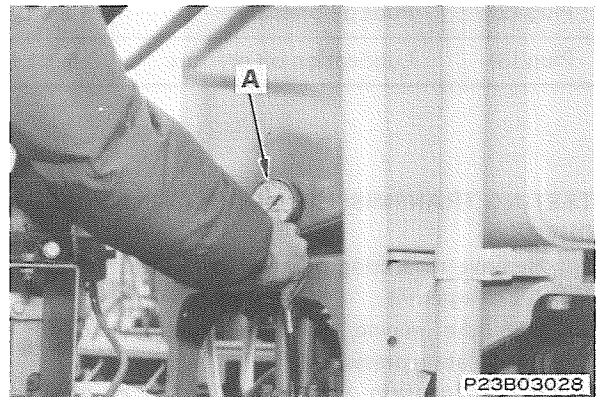
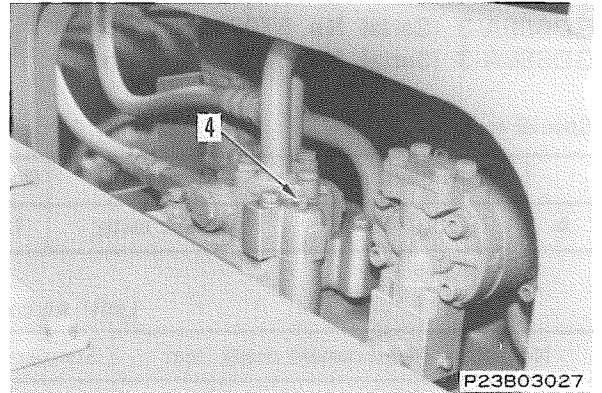

**ADJUSTING TRANSMISSION OIL PRESSURE (MODULATING PRESSURE)**

★ If oil pressure is outside standard value, adjust according to following procedure.

1. Remove transmission control valve assembly (4).
  - ★ For procedure of removing from chassis, see section, "TRANSMISSION CONTROL VALVE ASSEMBLY REMOVAL".

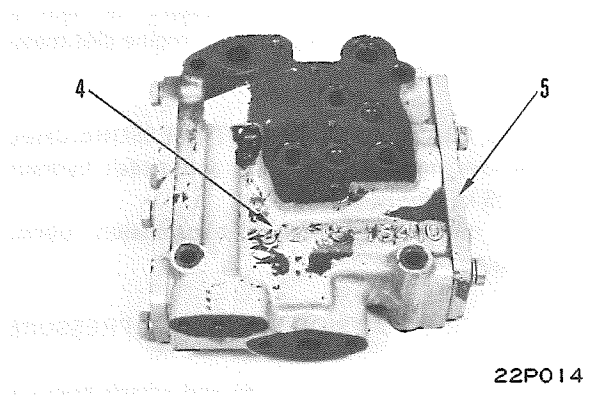

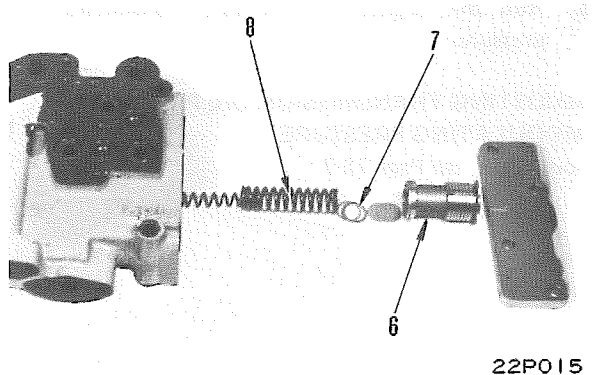

2. Remove cover (5) and valve (6).
3. Increase and decrease shims (7) and adjust spring (8) tension.
  - ★ Increase shims and oil pressure rises.
  - ★ Decrease shims and oil pressure falls.
  - ★ Standard shim thickness: 1.0 mm
  - ★ Kind of shim: 0.8 mm, 0.5 mm

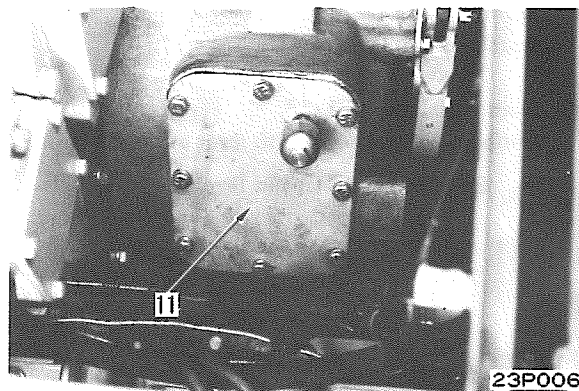

4. After adjustment confirm that transmission oil pressure (modulating pressure) is within standard value (25 kg/cm<sup>2</sup>), following procedure of section, "TRANSMISSION OIL PRESSURE (MODULATING PRESSURE) CHECK".

- 4) Attach gasket and install inspection cover (11).  
 Gasket: Gasket sealant (LG-1).



- 5) Adjusting clutch play  
 i) Remove cover (22).  
 ii) Loosen lock nut (23) and fully loosen adjustment bolt (24). Screw in bolt four turns and lock it with lock nut.  
 ★ At that time valve to piston clearance in booster should be 6mm.  
 iii) Attach gasket and install cover (22).  
 Gasket: Gasket sealant (LG-1).

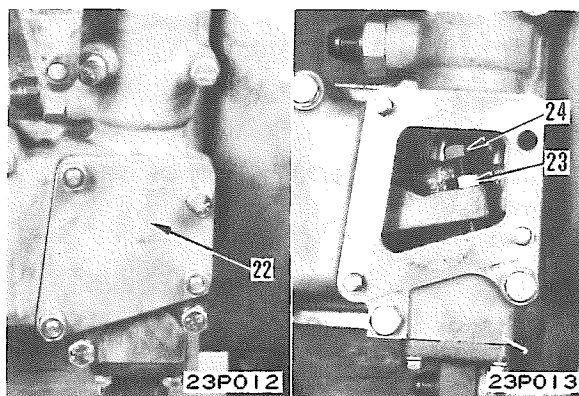

## 7. Clutch piping

- 1) Fit O-ring and connect main clutch case to transmission case tube (9) to main clutch.  
 2) Connect booster to transmission lubricating hose (8) to booster.

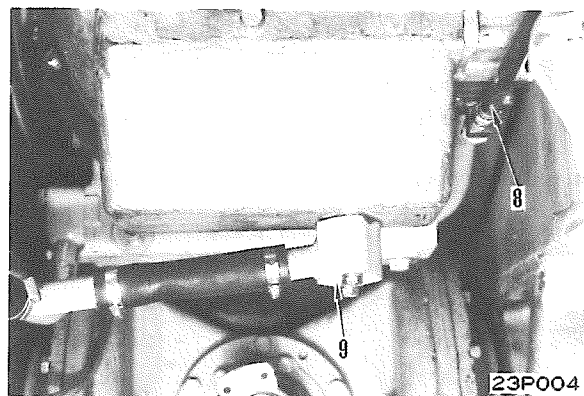

- 3) Fit O-ring and install lubricating valve (7) on main clutch case.  
 4) Install lubricating valve to booster tube (6).

## 8. Hydraulic pump outlet hose

- Connect hydraulic pump outlet hose (4) to tube (5).  
 ★ Install hose with care to avoid twisting and interference.

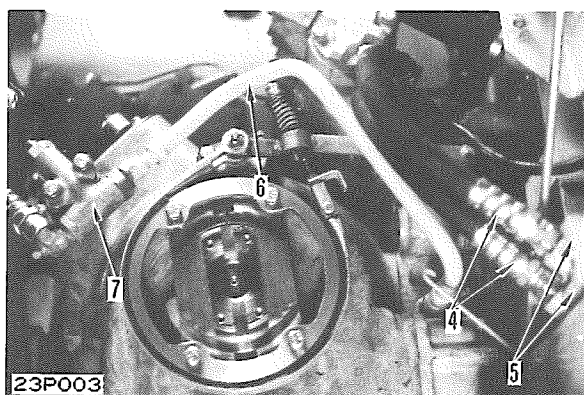

**7. Flange**

- 1) Install spring (4).
- 2) Using tool **A** compress spring and install flange (3).
  - ★ Bend down lock plate firmly.

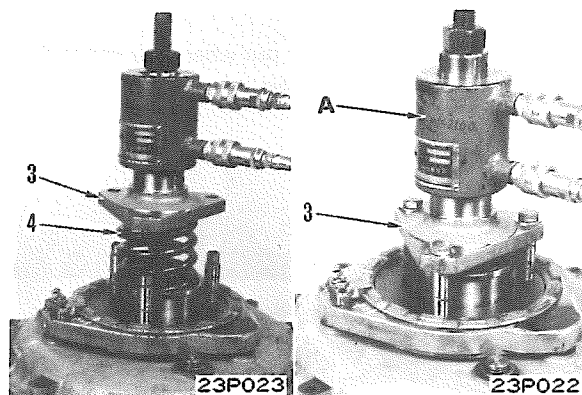
**8. Cage**

- 1) Press-fit bearing into cage and install cage (2) using push tool ② (φ65).

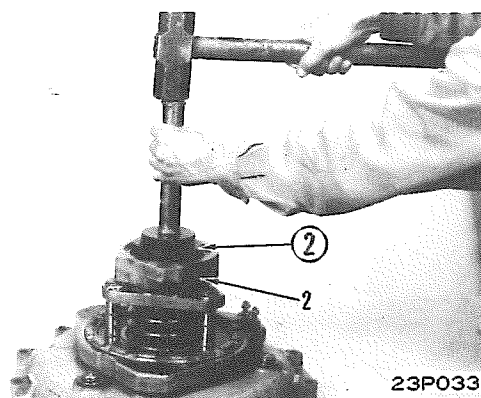

- 2) Install snap ring (1).

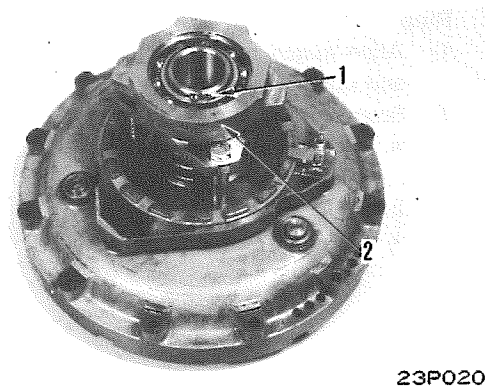

**3. Speedometer cable**

Connect speedometer cable (12).

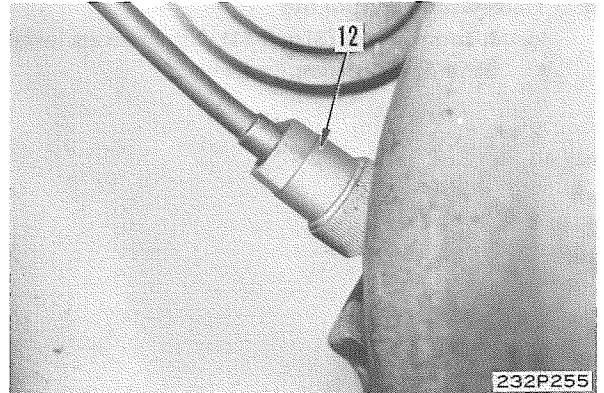
**4. Parking brake cable**

Connect parking brake cable (11).

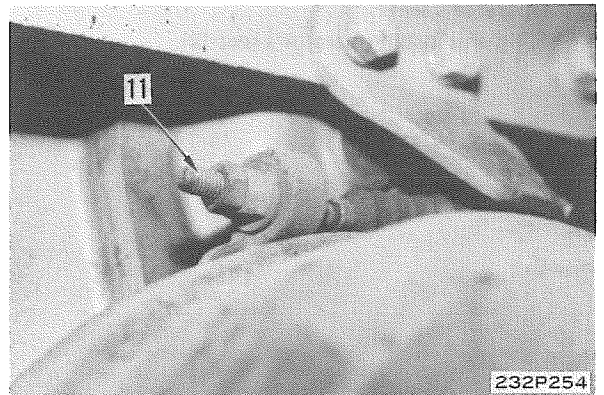
**5. Piping**

1) Connect hoses (8), (9), (10).

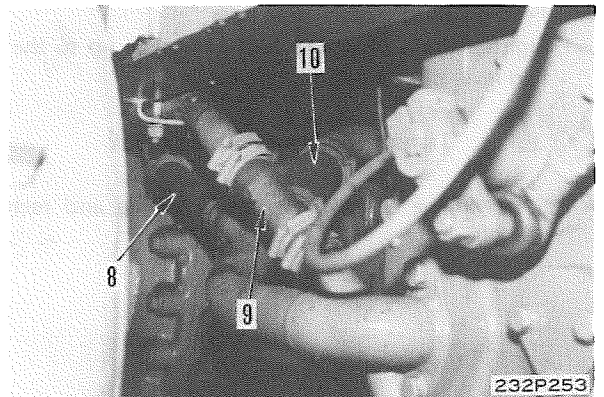

2) Connect transmission lubricating hose (7) to tube.

3) Fit O-ring and install oil filling port (5), and oil level gauge tube (6).

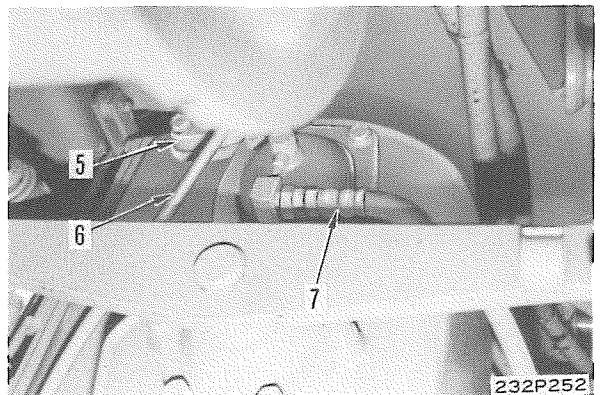

**ASSEMBLY OF TRANSMISSION**

GD600R-3  
GD650R-3

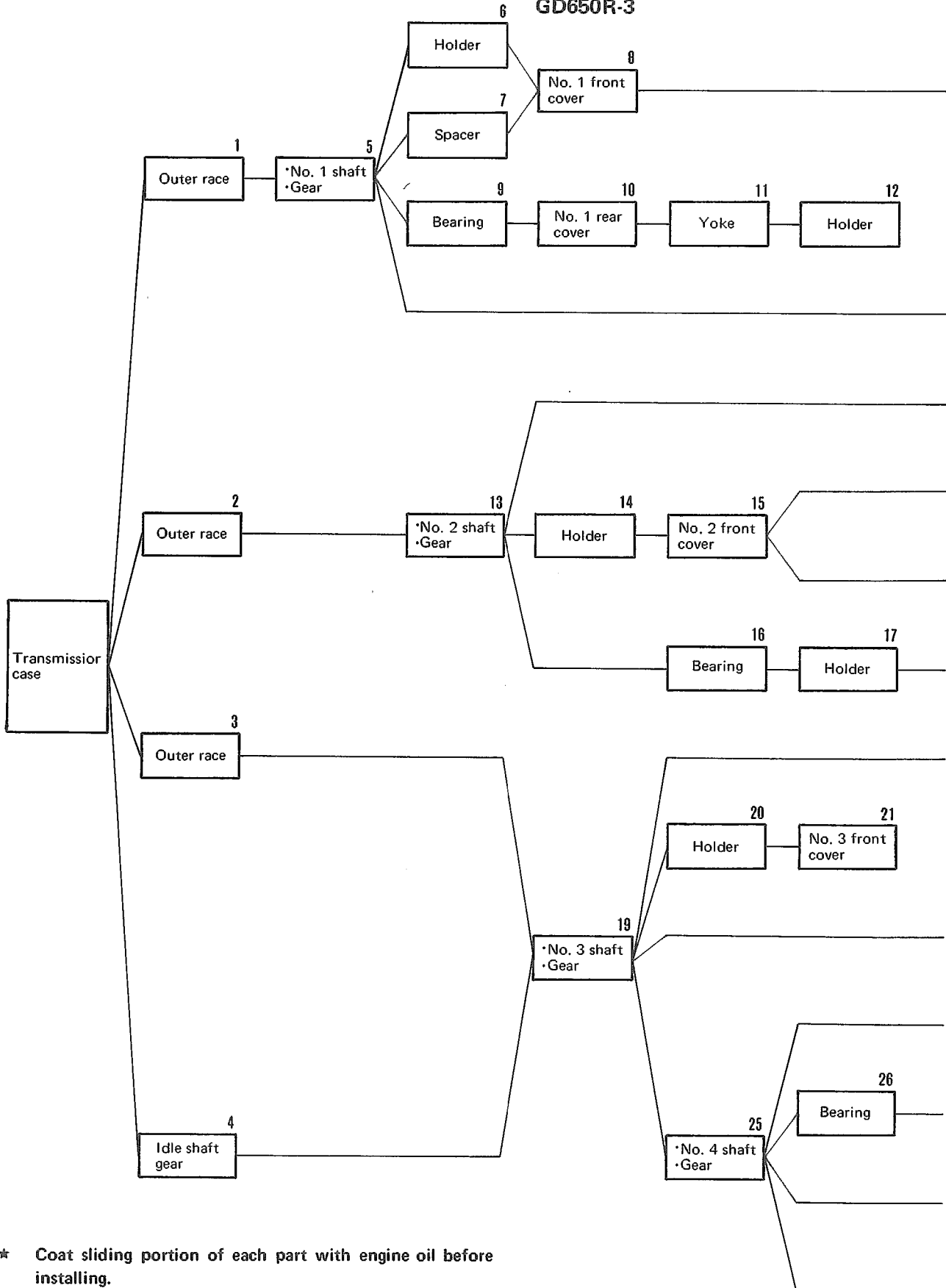

★ Coat sliding portion of each part with engine oil before installing.

**29. No. 4 front cover**

- 1) Fit O-ring and install No. 4 front cover (17).
- 2) After assembling each shaft and gear assembly, measure backlash of each gear and confirm that backlash is within standard shown in the Fig. 1 (Page 23-43).

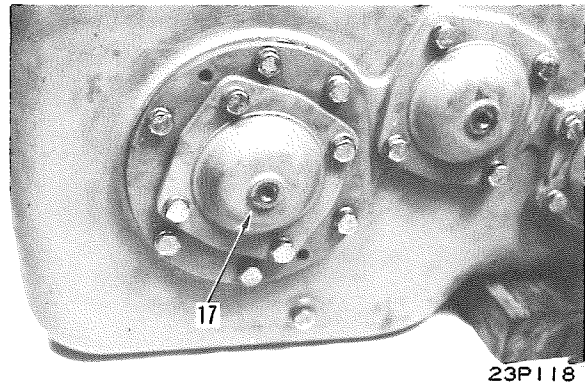

**30. Shifting fork cover**

- Attach gasket and install shifting fork cover (9).
- ★ Confirm that shifting fork is closely fitted in sliding gear groove.
-  Gasket: Gasket sealant (LG-1)

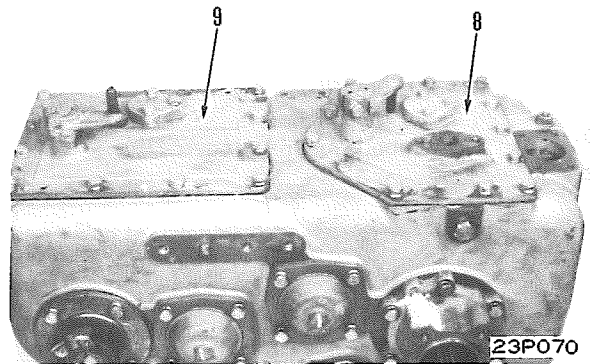

**31. Shifting fork cover**

- Attach gasket and install shifting fork cover (8).
- ★ Confirm that shifting fork is closely fitted in sliding gear groove.
-  Gasket: Gasket sealant (LG-1)

**32. Lubricating tube**

- Attach gaskets to both ends and install lubricating tube (7), and oil level gauge tube (69), oil filler tube (70).

 Joint bolt:  $3 \pm 0.5\text{kgm}$

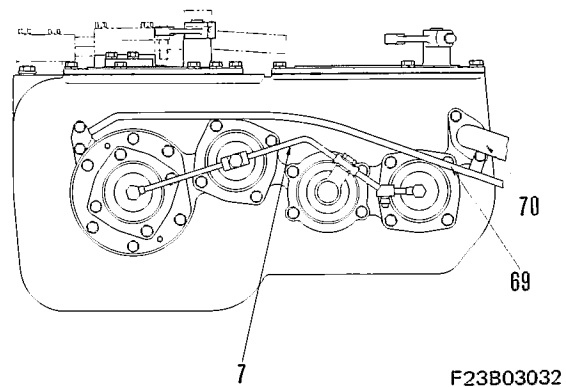

**33. Parking brake**

- 1) Fit O-ring and install speedometer shaft (15).
-  Speedometer shaft circumference:  
Grease (G2-L1)
- ★ Lock shaft with wire firmly.

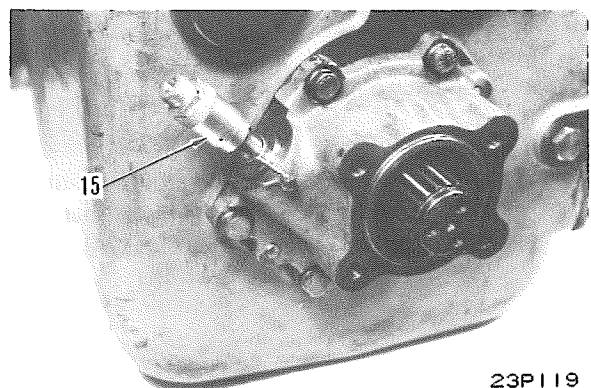

22. Reverse travel ring gear

Remove snap ring (33), remove ring gear (34).

23. Spring

Remove spring (35).

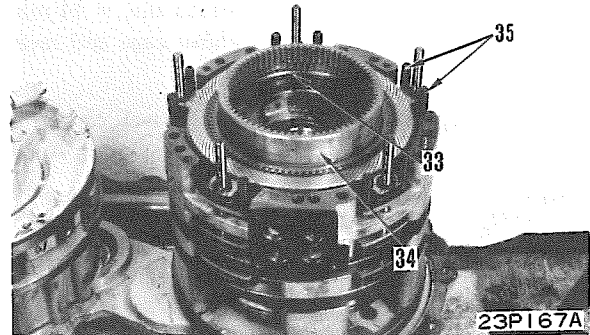

24. Spring, Disc, Plate

Remove spring (36), discs (37) and plates (38).

★ Disc: 3 pcs. Plate; 2 pcs.

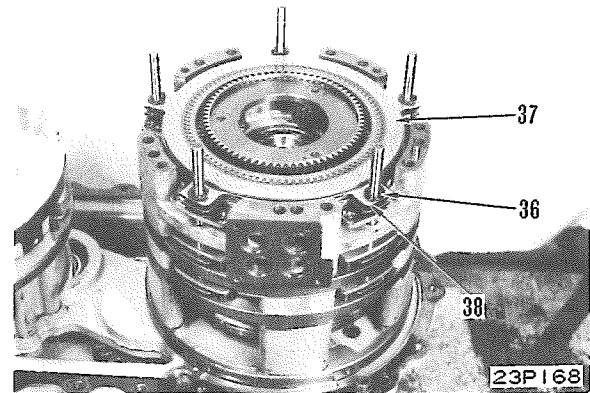

25. Ring gear

Remove ring gear (39).

★ Confirm installing direction of ring gear before removal.

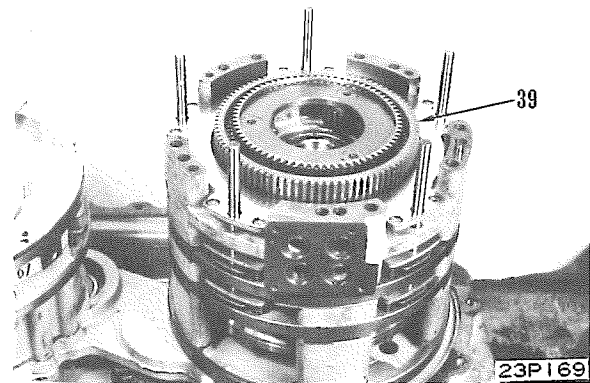

26. Forward travel and 3rd speed pistons and housing assembly

Install eye bolts ③ (Thread dia. = 14 mm, Pitch = 2.0 mm). Sling and remove forward travel and 3rd speed pistons and housings assembly (40).

★ Hold 3rd speed piston by the hand to prevent falling.



Forward and 3rd speed pistons and housings assembly: Approx. 35kg

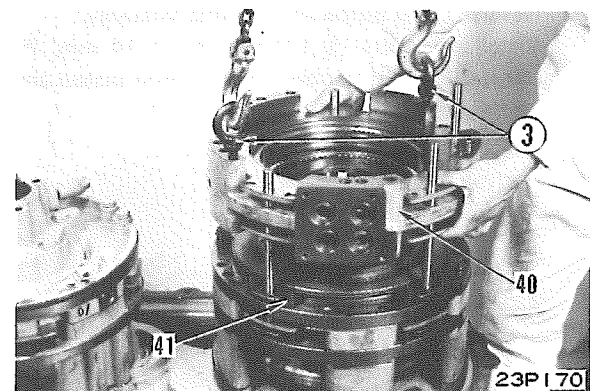

27. Spring

Remove spring (41).

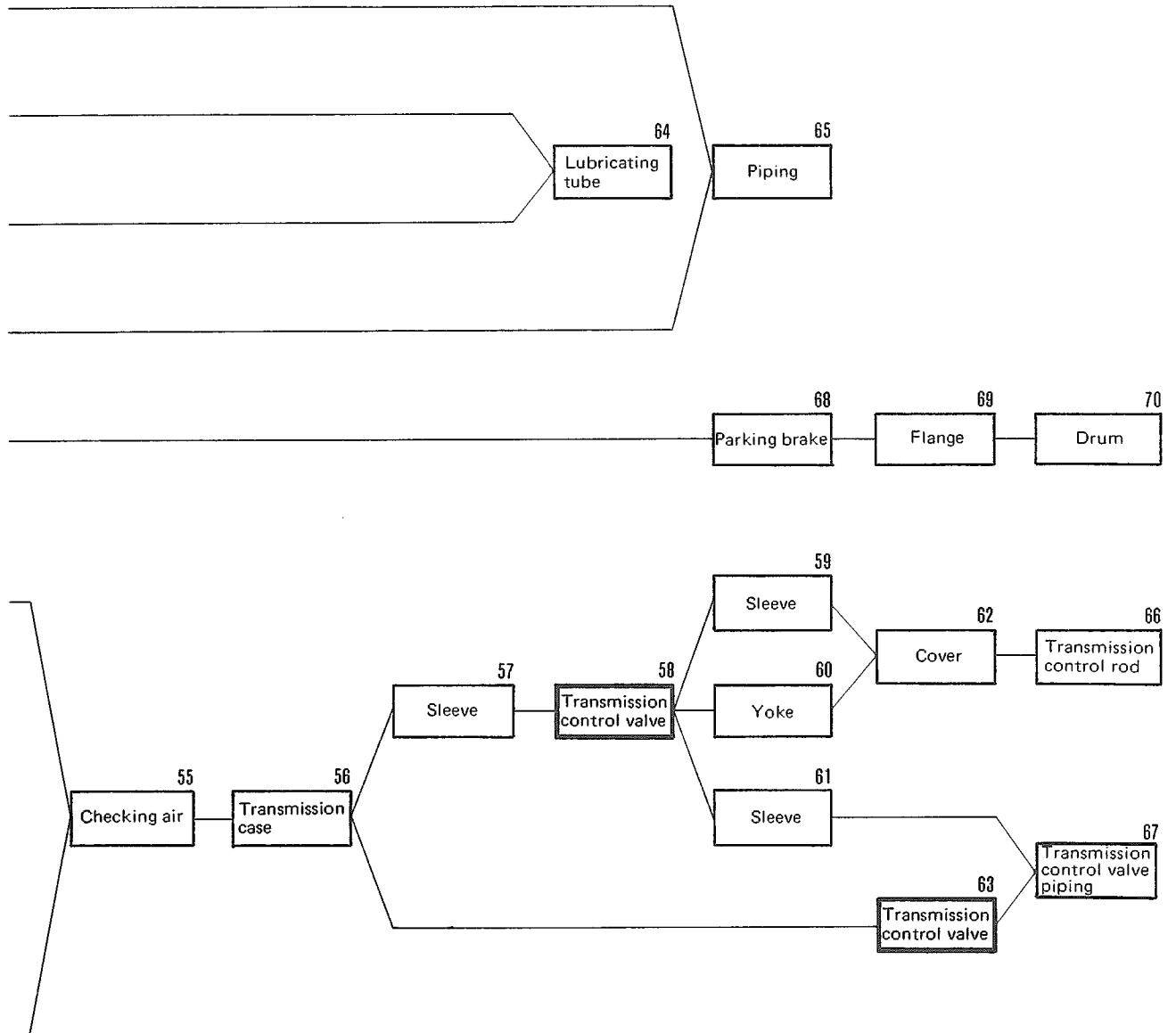

★ Apply engine oil to sliding portion of each part before installing.

1. Valve

- 1) Fix transfer case with its mounting face down.
- 2) Install sleeve (92), install spring (91), valve (90) and plate (89).

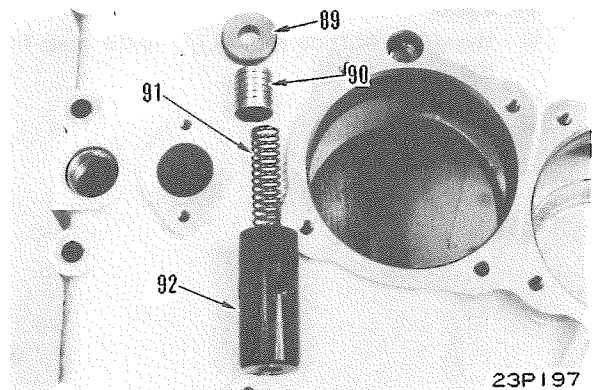

23P197

**33. 2nd speed ring gear**

Install 2nd speed ring gear (58).

- ★ Install ring gear with its recessed inner teeth side down.

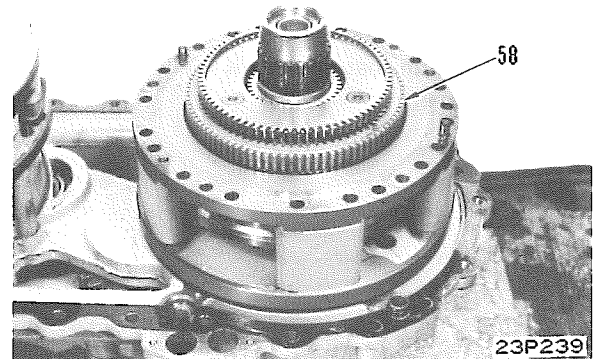
**34. Pin**

Install pin (45).

**35. Spring, Disc, Plate**

Install spring (55), discs (56) and plate (57) in order.

- ★ Install discs aligning notches of inner teeth in the same position.
- ★ Disc: 2 pcs. Plate: 1 pc.

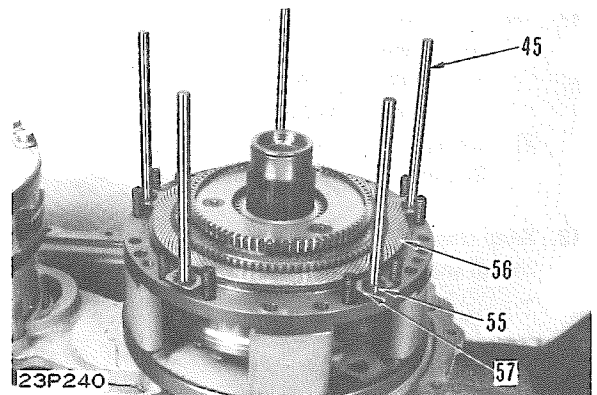
**36. Spring**

Install spring (54).

**37. 2nd speed piston and housing assembly**

- 1) Install seal ring and install piston in housing.
- 2) Install 2nd speed piston and housing assembly (53).
  - ★ Hold piston by the hand to prevent falling off.
  - ★ Confirm that spring (54) is firmly installed in housing and piston groove.

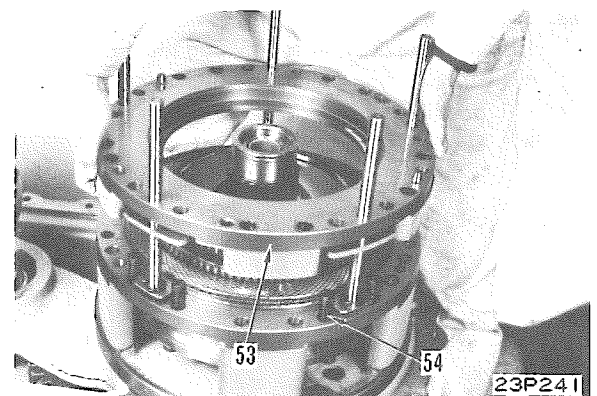
**38. 3rd speed sun gear**

Install 3rd speed sun gear (49).

**39. Spacer**

Install spacer (48).

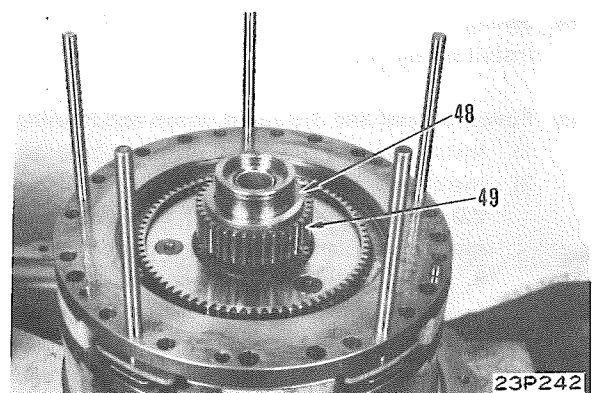

# ASSEMBLY OF CAGE AND REVERSE CARRIER ASSEMBLY

GD605R, GD655R, GD605A, GD655A-3

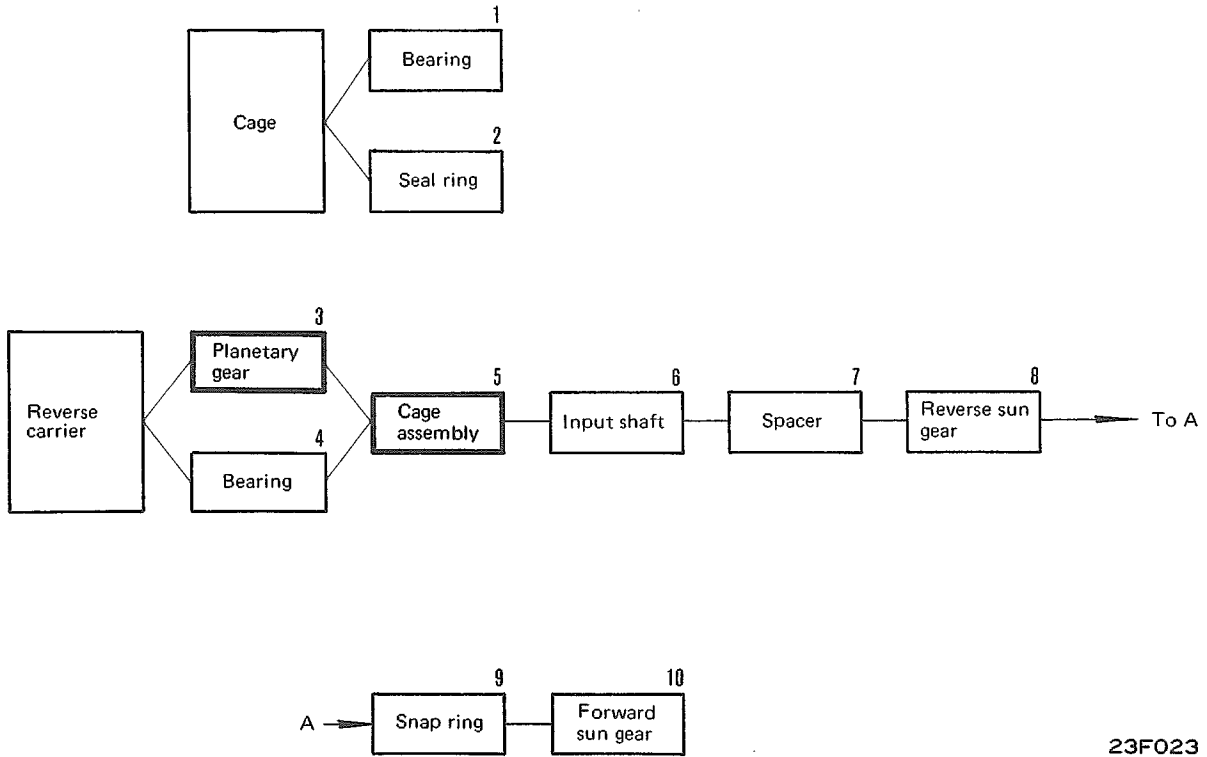

23F023

★ Coat sliding portion of each part with engine oil before installing.

**1. Bearing**

- 1) Using press-fitting tool ⑤ (φ160) press-fit bearing (12).
- 2) Install snap ring (11).

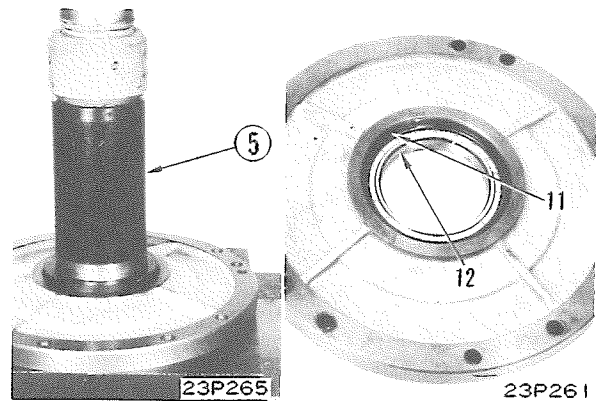

**2. Seal ring**

Install seal ring (10).

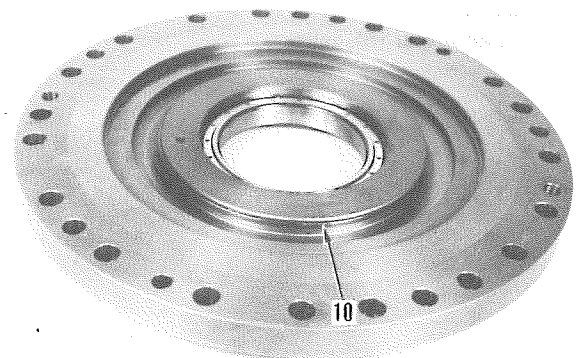

23P260

3. Cage assembly

Using press-fitting tool ④ (φ115) press-fit cage assembly (22) to cage (21).

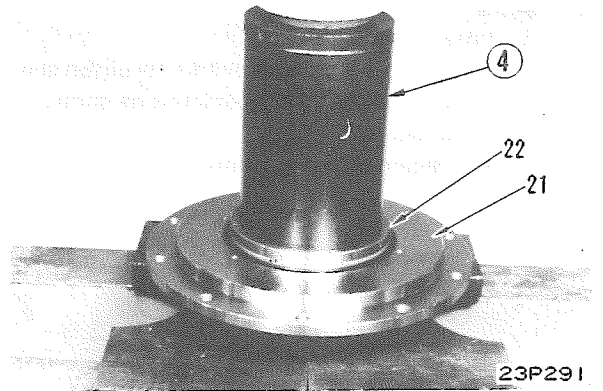

4. Cage

Install cage (23) aligning its oil vent with that on cage (21).

★ Install cage using care not to damage seal ring.

 Mounting bolt: Thread tightener (LT-2)

 Mounting bolt: 1.35 ± 0.15kgm

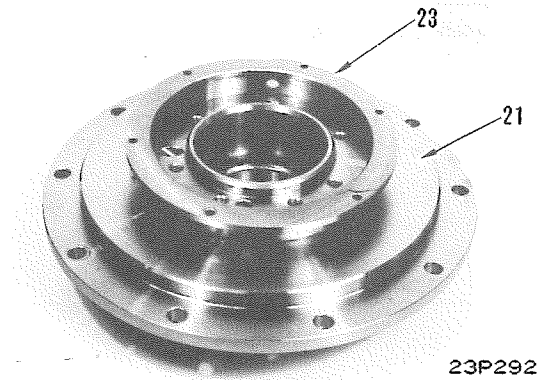

5. Piston assembly

1) Install seal rings (29) and (30) on piston.

★ Install seal rings using care to avoid twisting.

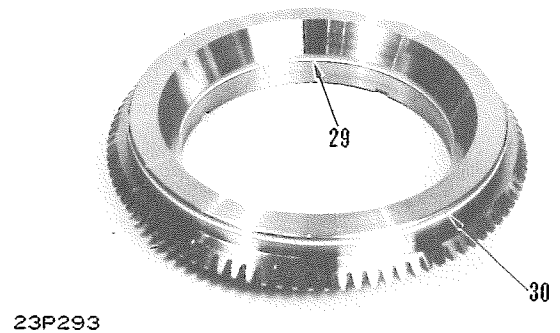

2) Install piston assembly (19) aligned with match mark put when disassembled.

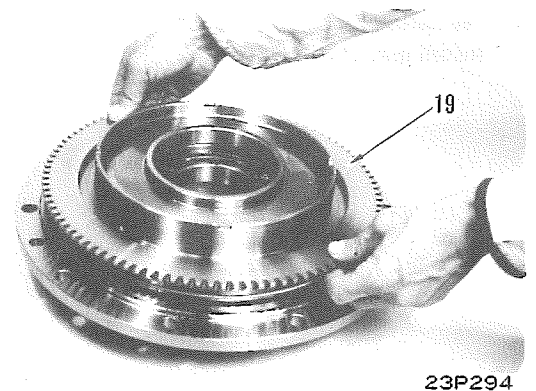

- 2) Confirm that match marks on piston and carrier are aligned and install snap ring (13) by compressing spring with press, using tool A.

★ Secure snap ring firmly.

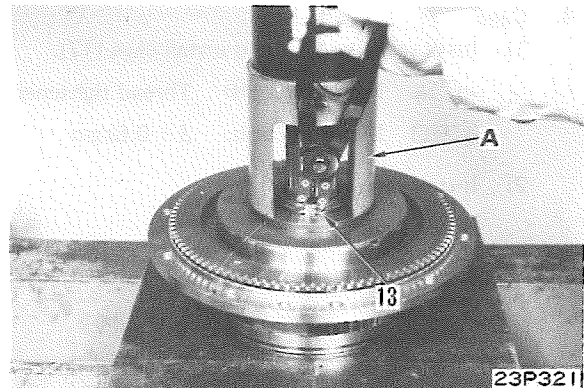

### 7 High gear

Install gear (9).

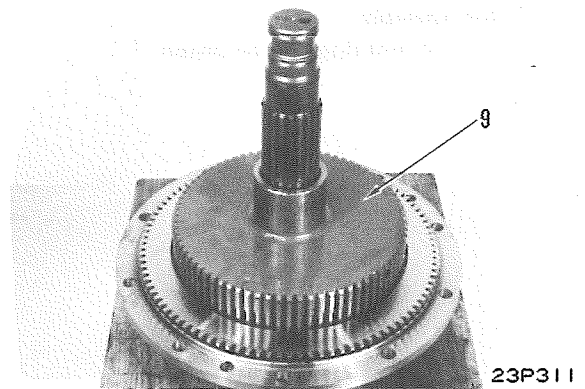

### 8. Spring, Disc, Plate

Install spring (6), discs (7) and paltes (8) in order.

★ Disc: 3 pcs. Plate: 2 pcs.

★ Align plate internal teeth with piston external teeth.

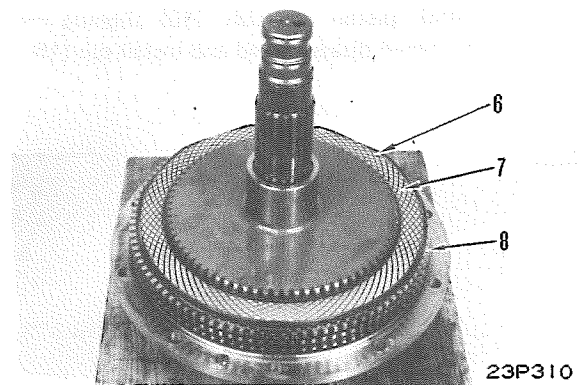

### 9. Drum

- 1) Press-fit bearing outer race to drum.
- 2) Install drum (5) aligning mounting bolt holes.

 Mounting bolt:  $11 \pm 1.5\text{kgm}$

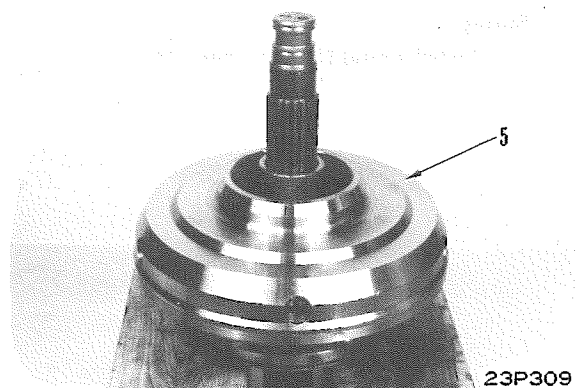

# INSTALLATION OF BEVEL PINION ASSEMBLY

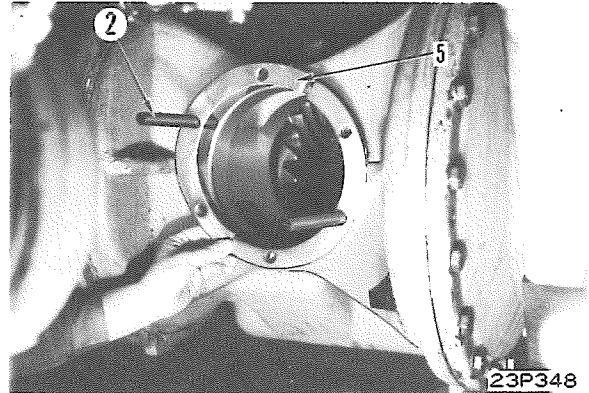
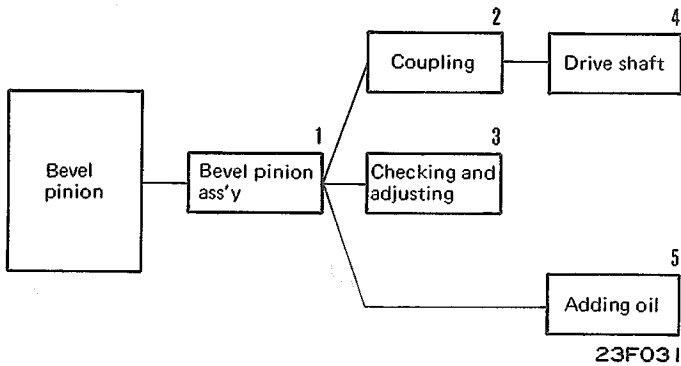

## 1. Bevel pinion assembly

- 1) Install two guide bolts (2) (Thread dia. = 14mm, Pitch = 2.0 mm, Length = Approx. 200 mm) in bolt holes at final drive side.
- 2) Install shims (5) for adjusting backlash.
  - ★ Install shims for adjusting of the same thickness as that before removal.
  - ★ Standard shim thickness: 2.0mm
  - ★ Kinds of shims: t = 1.0 mm, 0.2 mm and 0.5 mm
- 3) Install bevel pinion assembly (4).

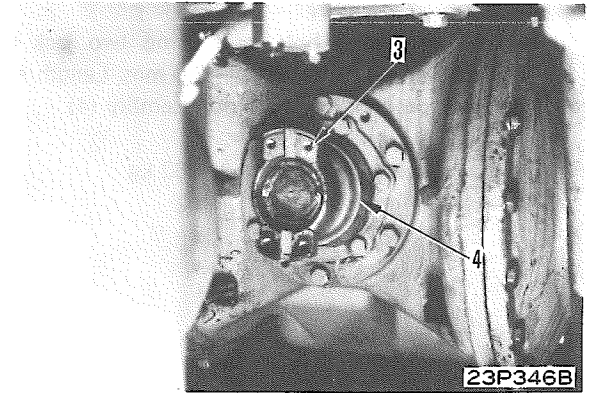

## 2. Coupling

Install coupling (3).

## 3. Checking and adjusting

- 1) Adjustment of backlash can be accomplished by increasing or decreasing shims (5).
  - ★ Backlash: 0.3 to 0.4 mm
- 2) Refer to "CHECKING AND ADJUSTING" section in "INSTALLATION OF FINAL DRIVE ASSEMBLY" section for adjusting tooth contact.
  - ★ Tooth contact
    - a . . . . . Tooth contact width 30 to 50%
    - b . . . . . Tooth contact center 20 to 40%

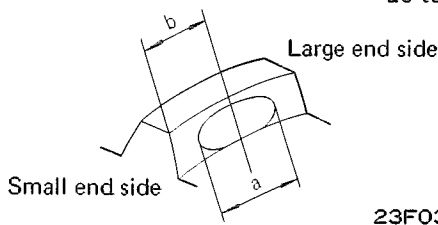
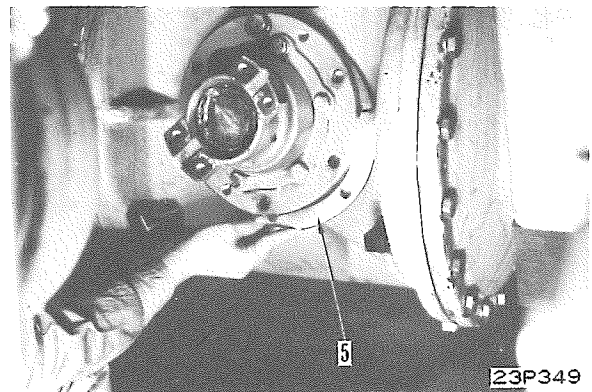

- ★ If adjustment is carried out when bevel pinion is mounted on machine, raise up machine body, place block under case, remove hanger, oil filling port and cover, check and adjust by rotating wheel.

## 4. Drive shaft

Install drive shaft (2).

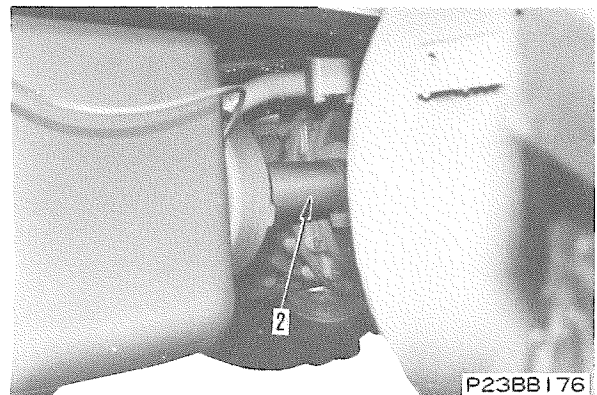

- 2) Install spider assembly (10).

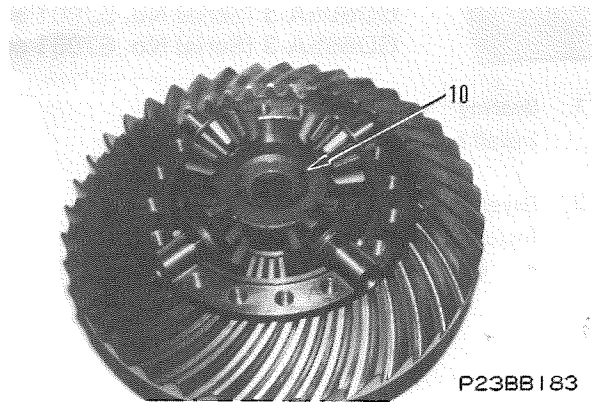

6. Case, gear assembly

- 1) Install bearing (9).

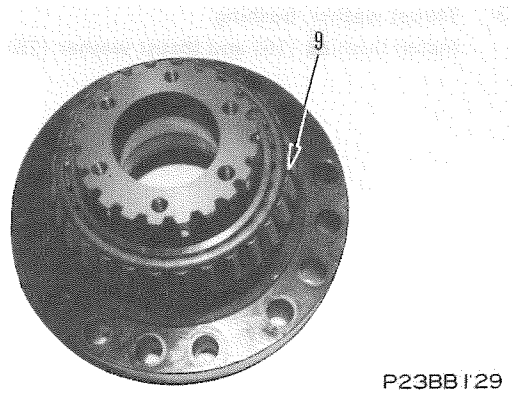

- 2) Install thrust washer (7) to bushing (8).

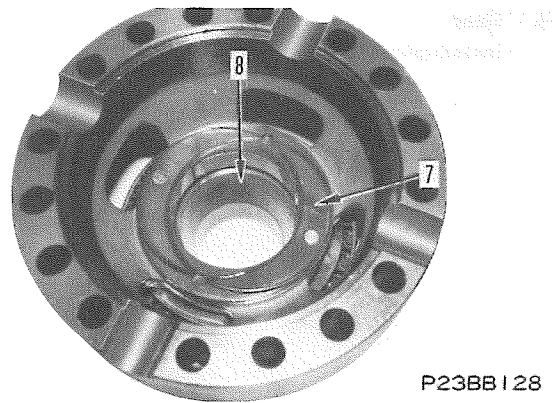

- 3) Install gear (6).

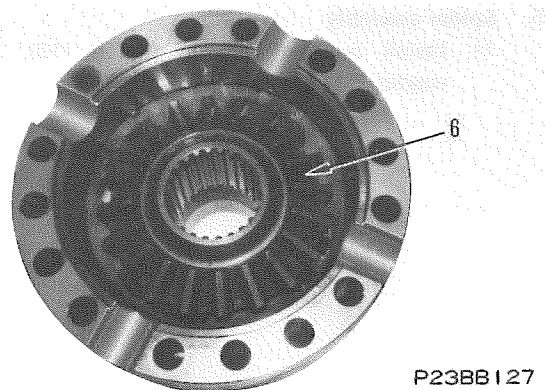

4. Tandem case assembly

- 1) Suspend tandem case assembly (9).

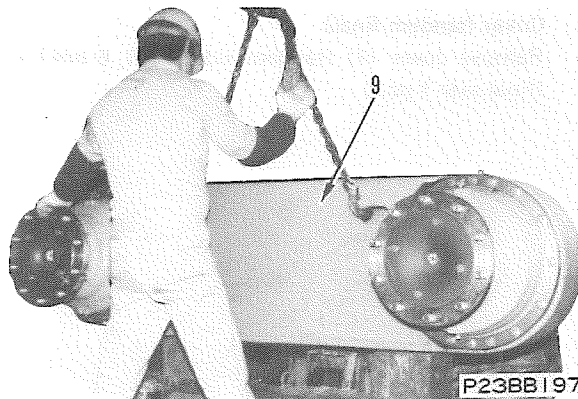

- 2) i) Remove mounting bolts (10) and dismount the tandem case assembly.

 Tandem case assembly:  
Approx. 750 kg (one side)

- ★ When dismounting the tandem case assembly, be careful to maintain it in a balanced condition in order to prevent the contact face of the O-ring on the case side from being damaged.

- ii) Dismount cover (11).
  - ★ Keep shims on one side so they don't get mixed up.

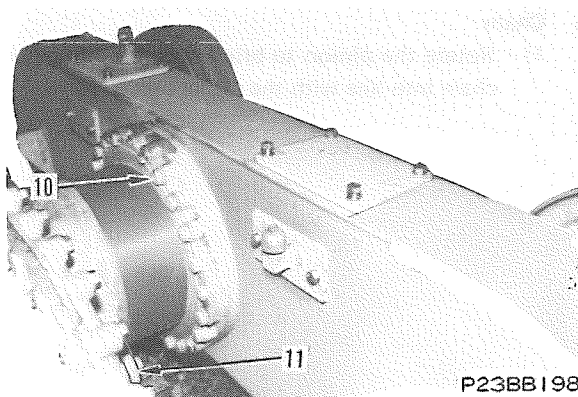

5. Bevel pinion assembly

- 1) Dismount coupling (12).
- 2) Remove the mounting bolts, then dismount bevel pinion assembly (13).

 Bevel pinion assembly: Approx. 62 kg

- ★ Check the number and positions of the shims which were removed.

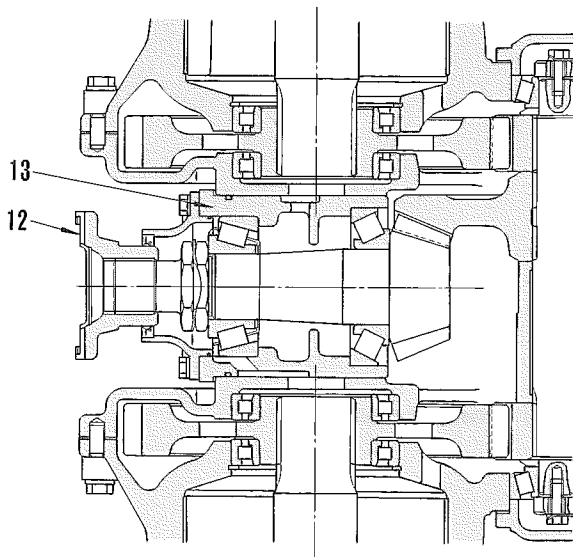

CLICK HERE TO **DOWNLOAD** THE COMPLETE MANUAL

- Thank you very much for reading the preview of the manual.
- You can download the complete manual from: [www.heydownloads.com](http://www.heydownloads.com) by clicking the link below



- Please note: If there is no response to CLICKING the link, please download this PDF first and then click on it.

CLICK HERE TO **DOWNLOAD** THE COMPLETE MANUAL

## DISASSEMBLY OF FINAL DRIVE ASSEMBLY

GD605A-3 (Serial No. 57001 and up)  
GD655A-3 (Serial No. 67001 and up)

### Special tools

	Part number	Part name	Q'ty
A	792-571-1600	Chain puller	1
B	792-571-1400	Wrench (for R.H. nut)	1
C	792-571-1500	Wrench (for L.H. nut)	1

### 1. Tandem and final drive assembly

- 1) For details, see "REMOVAL OF TANDEM AND FINAL DRIVE ASSEMBLY".
- 2) Raise tandem and final drive assembly (1) with crane and remove wheel (2).



Tandem and final drive assembly:

Approx. 3100 kg

- 3) Set tandem and final drive assembly on block ①, remove drain plug (3) and drain oil from tandem case.



Tandem case (each): Approx. 100ℓ

- 4) Remove drain plug and drain oil from final drive case.



Final drive case: Approx. 30ℓ

- ★ Set blocks underneath the left and right tandem case and final drive (three points).

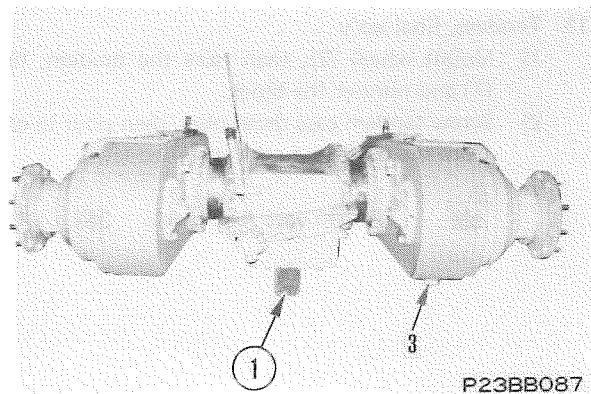
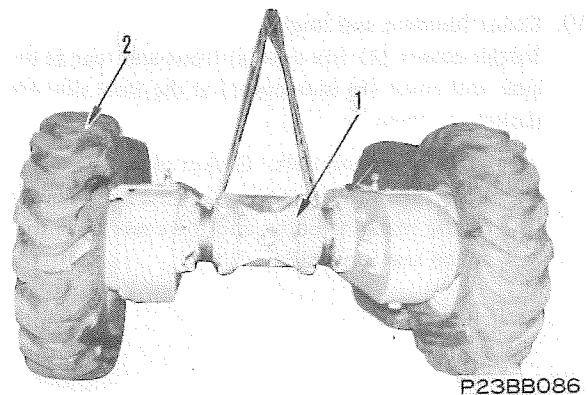

### 2. Cover

Remove cover (4) (6 pcs.).

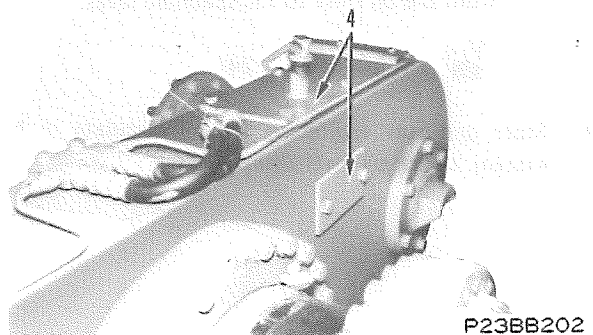

- 2) Install bushings (16), (17) to joint.  
 ★ Position slit of bushing as follows:  
 Direct slit of bushing (16) to lower side of body.  
 Direct slit of bushing (17) to upper side of body.

 Bushing (both end): Engine oil

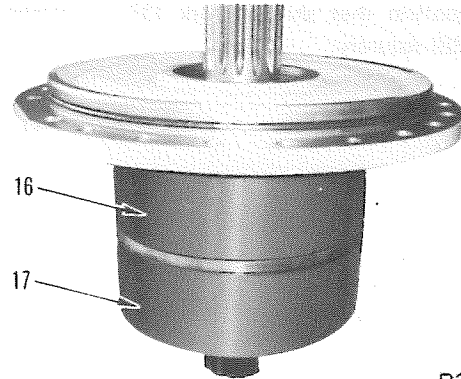

P23BB099

- 3) Lift shaft and joint assembly (15) with a crane and install it to side case.

 Shaft and joint assembly: Approx. 110 kg

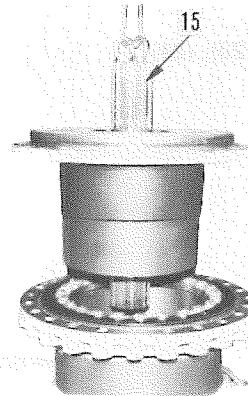

P23BB098

- 4) Install snap ring (14).

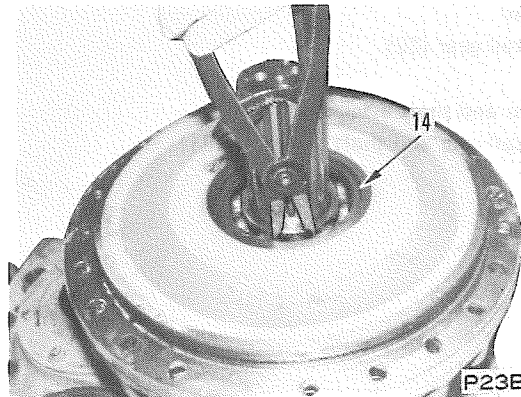

P23BB097

- 5) Install sprocket (12), collar (13).

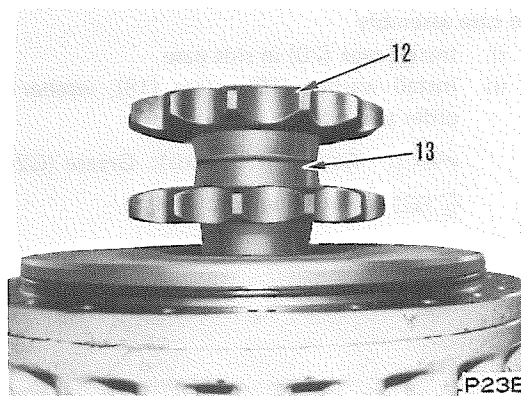

P23BB096

## REMOVAL OF WHEEL BRAKE AND SPROCKET ASSEMBLY

1. Remove wheel. For details, see "REMOVAL OF TANDEM AND FINAL DRIVE".
2. Remove chain. For details, see "REMOVAL OF CHAIN".
3. Remove cover (1) and disconnect brake tube (2).
4. Raise wheel brake (3) and sprocket assembly with crane and remove bolt.
5. Screw in jack bolt and dismount wheel brake and sprocket assembly.



Wheel brake and sprocket assembly: 200 kg

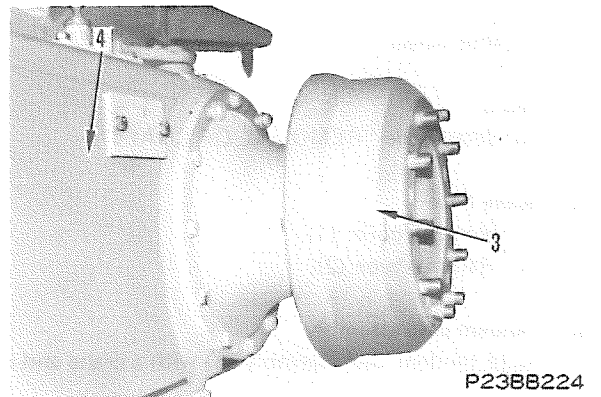
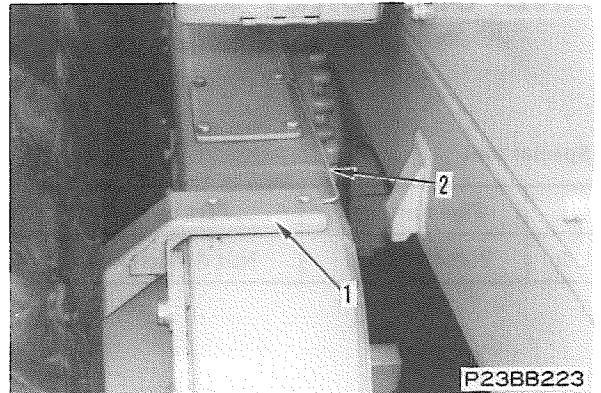

## INSTALLATION OF WHEEL BRAKE AND SPROCKET ASSEMBLY

1. Fit O-ring, raise wheel brake and sprocket assembly (3) with a crane and mount the assembly on tandem case (4).



Mounting bolt: Liquid gasket (LG-1)



Mounting bolt:  $23.5 \pm 7.5$  kgm

2. Connect brake tube (2) and install cover (1).
3. Install chain. For details, see "INSTALLATION OF CHAIN".
4. Install wheel. For details, see "INSTALLATION OF TANDEM CASE ASSEMBLY AND SPROCKET".
5. Adjust wheel brake. For details, see "TESTING AND ADJUSTING OF BRAKE".

3. **Spacer**  
Remove spacers (4), (5).

4. **Sprocket**  
Remove sprocket (6).

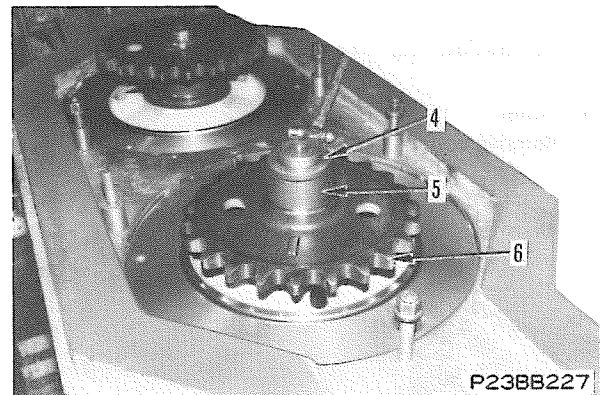

5. **Spacer**  
Remove spacer (7).

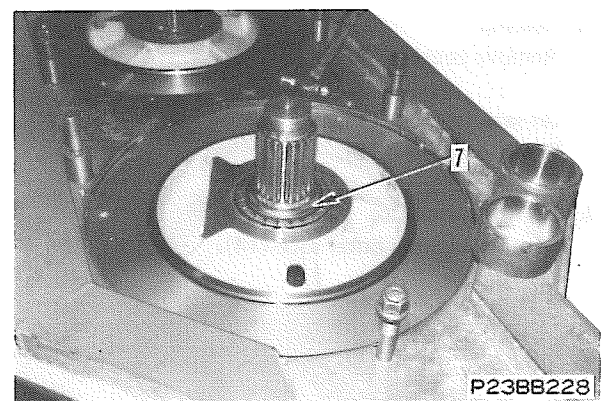

6. **Hub shaft**  
Raise hub shaft (8) with a crane and remove it.

 Hub shaft assembly: 65 kg

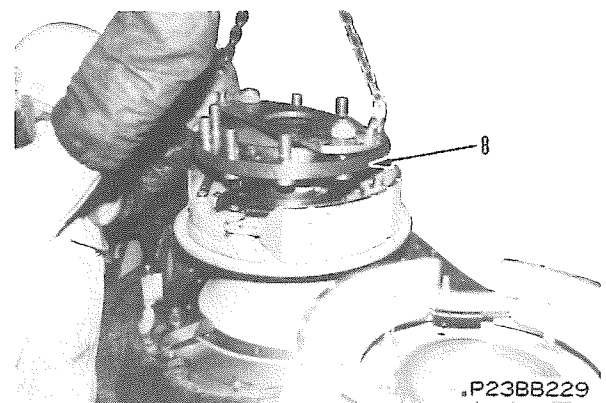

7. **Brake shoe assembly**  
Remove mounting bolt (9) and remove brake shoe assembly (10).

 Brake shoe assembly: 27 kg

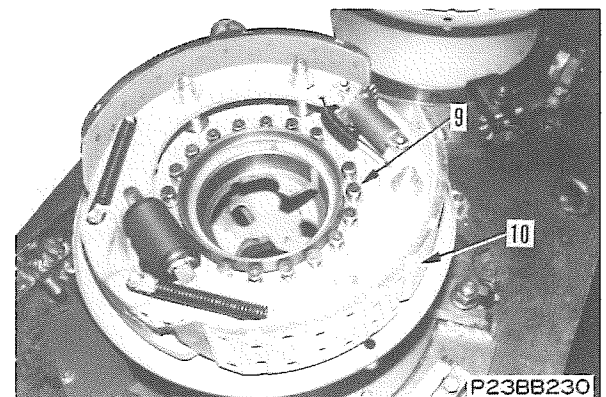

# MAIN CLUTCH

GD600R-3  
GD650R-3

## 1. Plate, Gear, Shaft

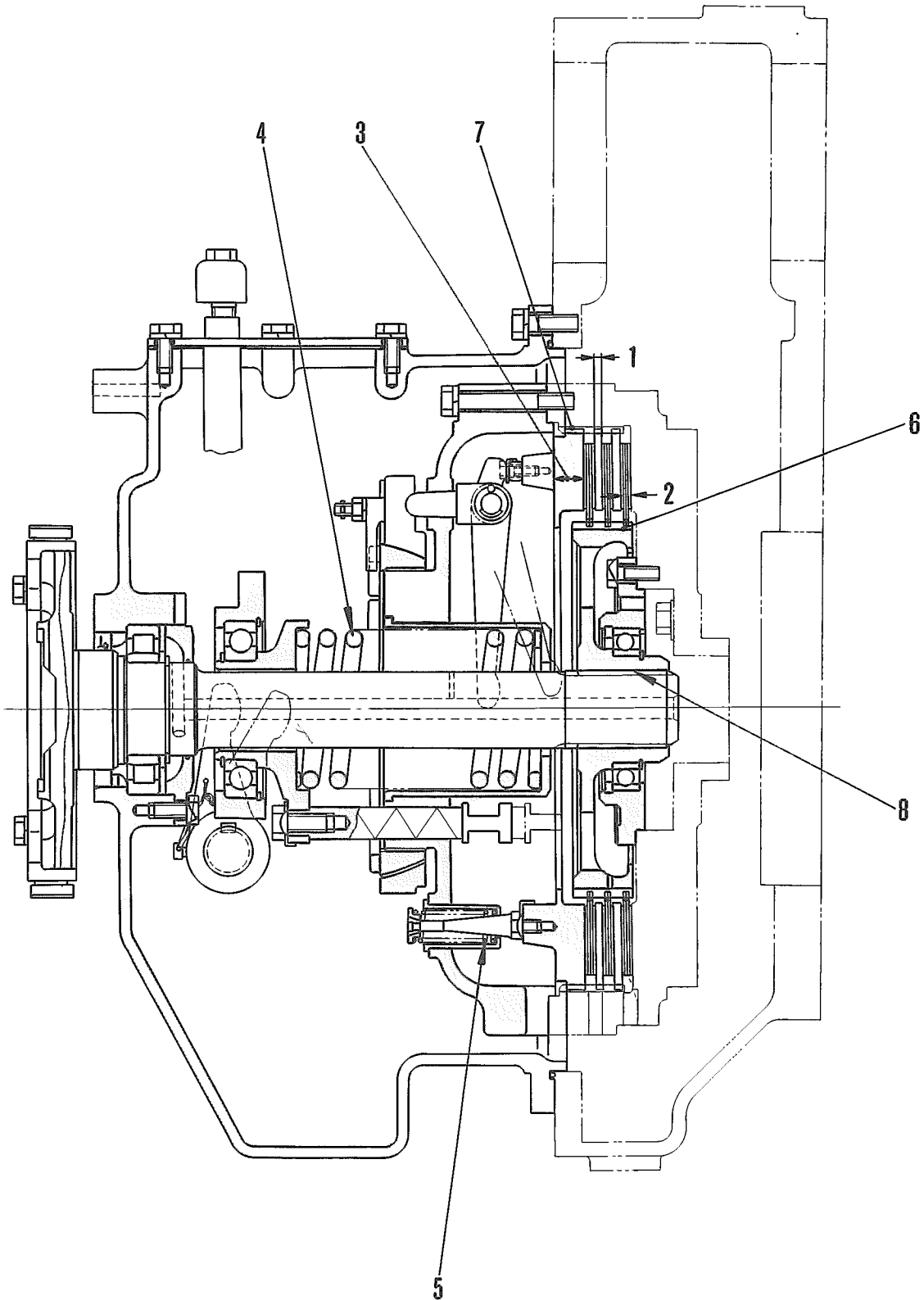

24F001

Unit: mm

No.	Check Item	Criteria		Remedy
23	Assembled thickness of disc and plate for R, F, 1st, L.H.	Standard size	Repair limit	
		25	23.5	
24	Assembled thickness of disc and plate for 3rd, 2nd clutch	15	14.1	
25	Thickness of one plate	5	4.7	
26	Side clearance of planetary gear	Standard clearance	Clearance limit	
		0.35 – 0.80	1.5	
27	Thickness of shim	Standard thickness	Repair limit	
		2.0	—	
28	Bolt tightening torque	17 ± 1 kgm		
29	Bolt tightening torque	6.5 ± 1.0 kgm		
30	Cage mounting bolt tightening torque	17 ± 1 kgm		
31	Bolt tightening torque	1.4 ± 0.1 kgm		
32	Bolt tightening torque	11.0 ± 1.5 kgm		
33	Cover mounting bolt tightening torque	11.0 ± 1.5 kgm		
34	Bolt tightening torque	3.0 ± 0.5 kgm		
35	Housing mounting bolt tightening torque	17 ± 1 kgm		
36	Plug tightening torque	0.8 kgm		
37	Holder fixing bolt tightening torque	23.5 ± 2.5 kgm		
38	Cage mounting bolt tightening torque	11.0 ± 1.5 kgm		
39	Bolt tightening torque	11.0 ± 1.5 kgm		
40	Plug tightening torque	0.8 kgm		
41	Drain plug tightening torque	15.5 ± 2.5 kgm		

### TANDEM DRIVE (WITH DISC BRAKE)

GD605A-3 (Serial No. 57001 and up)  
 GD655A-3 (Serial No. 67001 and up)

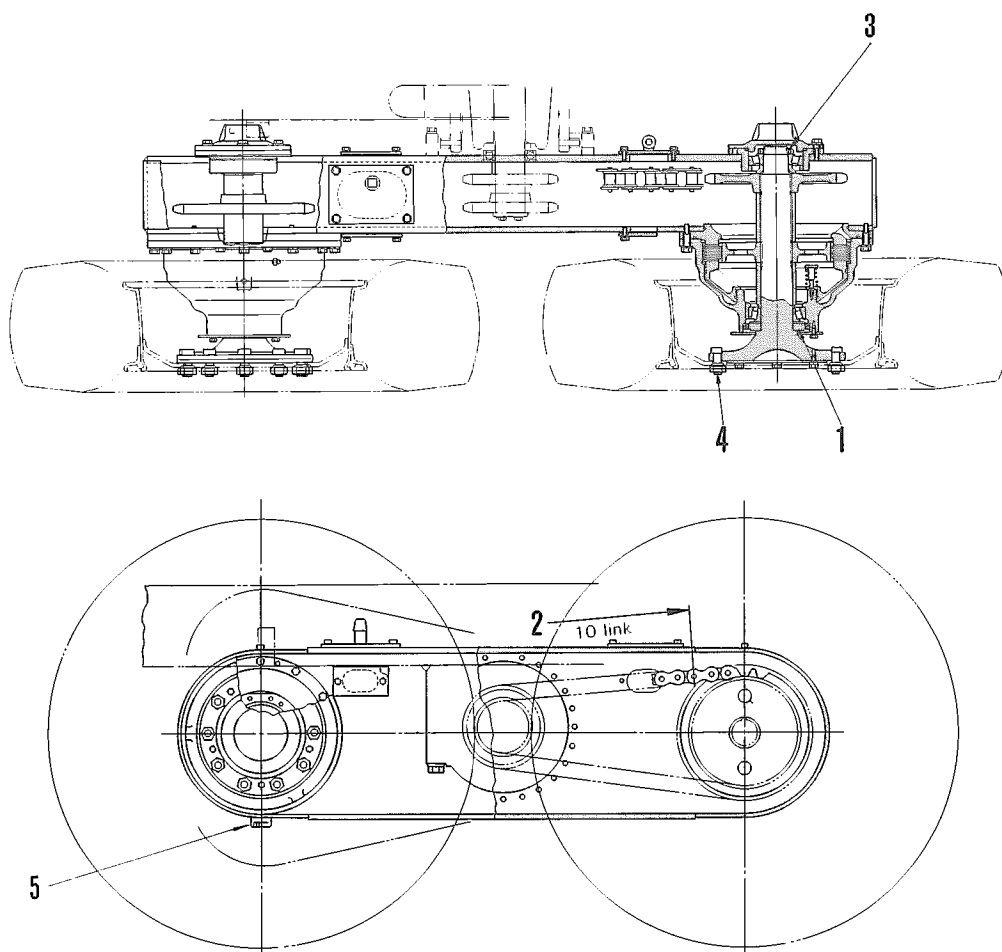

F23B109A

Unit: mm

No.	Check Item	Criteria		Remedy
1	Hub bearing preload	Starting torque (required to shaft with bearings not preloaded) + (2.0 – 2.5 kgm)		Adjust
2	Extension of chain (10 links)	Standard size	Repair limit	Replace
		508.0	515.7	
3	Nut tightening torque of rear axle shaft	25 kgm		Adjust
4	Hub nut tightening torque	50 ± 5 kgm		
5	Drain plug tightening torque	7 ± 1 kgm		

OPERATION

When steering wheel is not manipulated

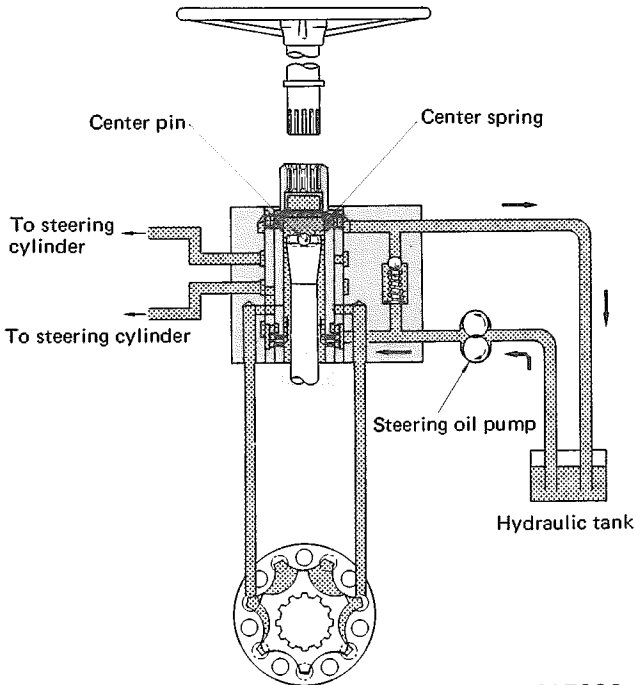

41F003

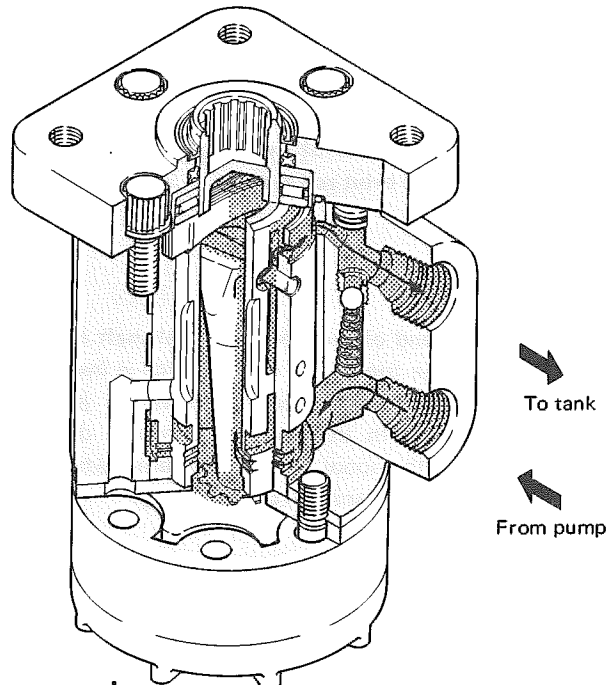

41F004

When the steering wheel is not manipulated, the center spring keeps the spool and the sleeve are stopped in the position at which the center pin is located to the center of the slotted hole in the spool. Under this condition, the ports that connect the sleeve to the steering cylinder and the hand pump are insulated from the lengthwise slots in the spool. While, the small holes in the spool bottom are aligned with those in the sleeve bottom. (Total 24 holes are provided by arranging twin holes at 12 places equally spaced around the circumference of spool or sleeve.)

Oil from the pump enters the valve inlet port and flows through the small holes in the sleeve and spool to the inside of the spool. The oil, in turn, flows through the slotted hole in the spool and the spring mounting portion to the valve outlet port, and is returned to the tank.

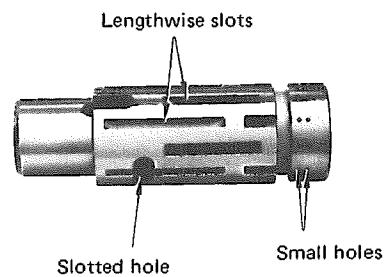

41P005

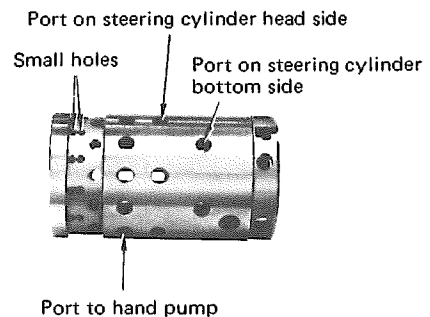

41P006

# FRONT AXLE

Toe-in 8.5mm, Camber 1.5°  
King pin tilting angle 8.5°

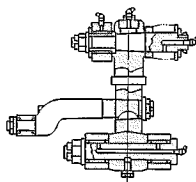
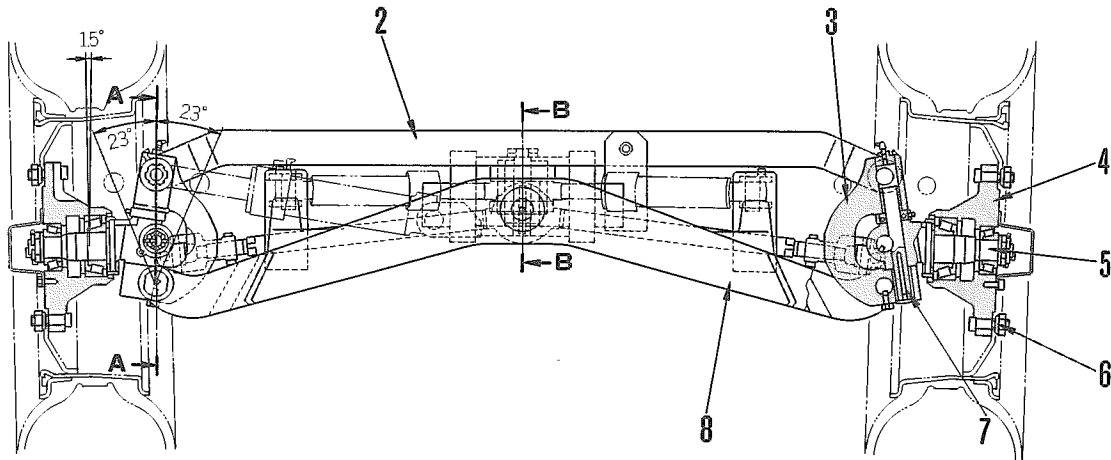
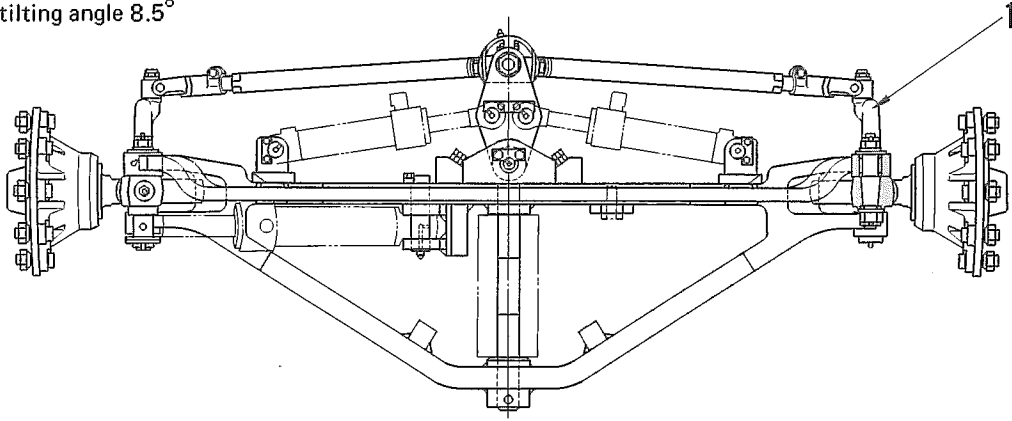

Section A-A

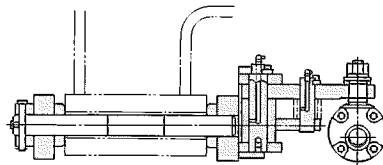

Section B-B

F23B022

- |                    |                  |
|--------------------|------------------|
| 1. Knuckle arm     | 5. Knuckle       |
| 2. Leaning rod     | 6. Hub bolt, Nut |
| 3. Knuckle bracket | 7. King pin      |
| 4. Hub             | 8. Front axle    |

**TIRE AND RIM NOMINAL DIMENSIONS**

**Tire Nominal Dimensions**

Tire nominal dimensions include tire width in inches, tire inner diameter in inches, and tire strength in ply rating, the three figures being joined by hyphens.

Example

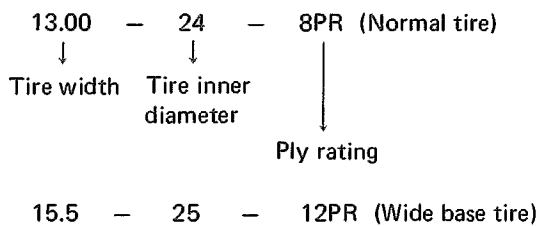

**Rim Nominal Dimensions**

Rim nominal dimensions include the width of the tire seat in inches plus a symbol denoting the shape of the edge, and the diameter of the tire seat (tire inner diameter) expressed in inches and joined by an X.

Example

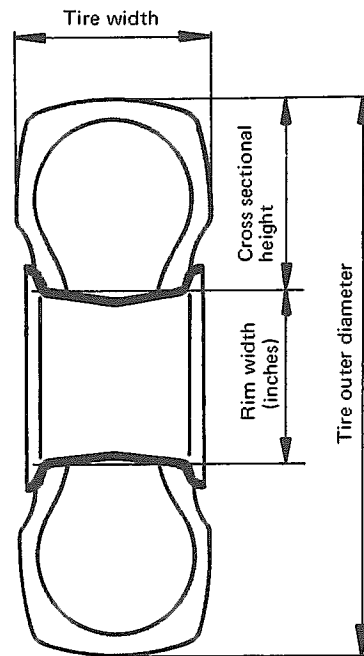
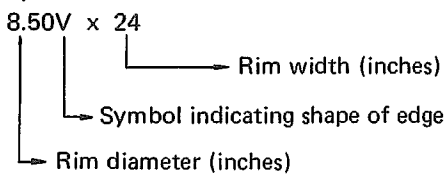

230F118

**TUBELESS TIRES**

Tubeless tires are commonly used on large dump trucks and large scrapers.

Structurally, tubeless tires include a special layer of rubber on the inside to preserve airtight conditions. The bead section must be very tough, and therefore uses relatively expensive materials. However, due to the difficulty in repairing punctures where the carcass is penetrated, tubeless tires are seldom used on small sized loaders.

With large sized loaders and dump trucks, where the benefits of greater service efficiency have been acknowledged, there is increasing interest in the use of tubeless tires.

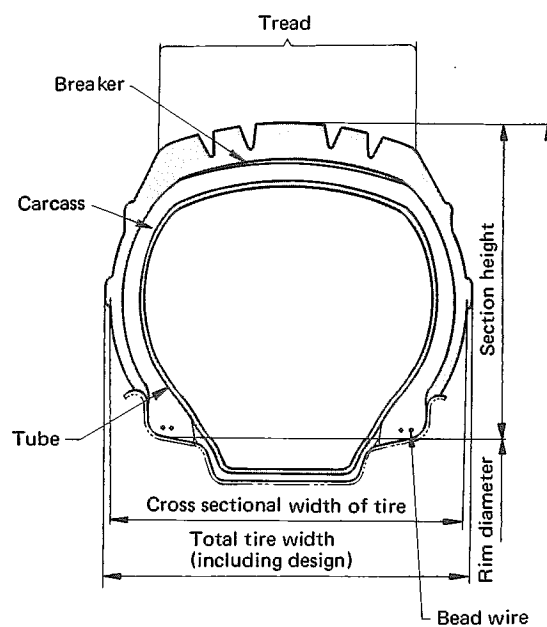

230F119

**3. Hub assembly**

- 1) Remove nuts (4).
- 2) Temporarily sling hub assembly (5). Using gear puller (2), pull out hub assembly and lift it out.

 Hub assembly: Approx. 500 kg

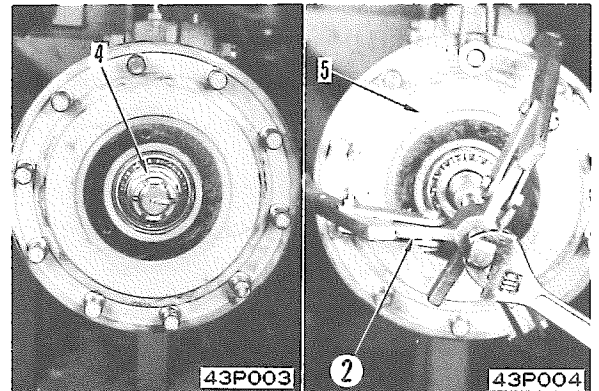
**4. Tie rod**

Remove nut (6) and disconnect tie rod (7).

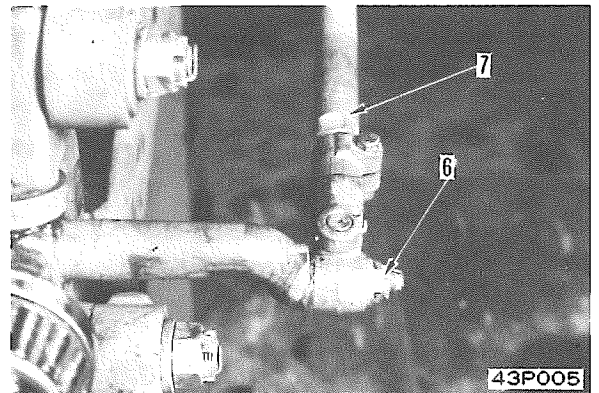
**5. Leaning rod**

Remove nut (8) and disconnect leaning rod (9).

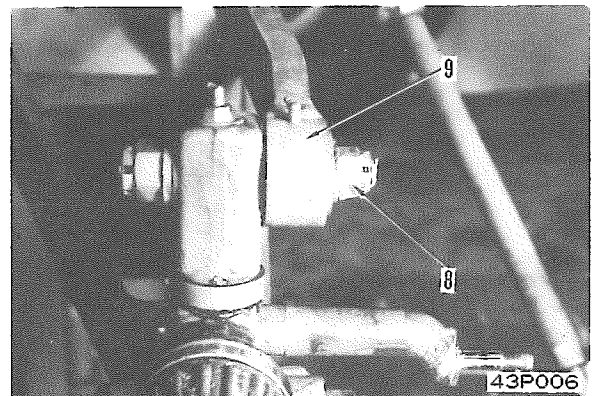
**6. Shaft**

Temporarily sling bracket and axle. Remove nut (10) and pull out shaft (11).

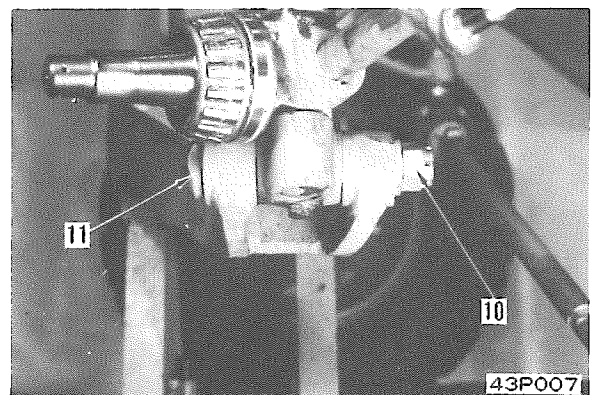

---

# STEERING SYSTEM

## 44 MAINTENANCE STANDARD

---

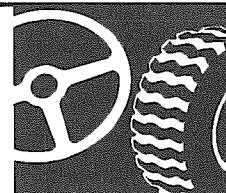

Steering pump .....	44-2
Front axle .....	44-4
Steering cylinder .....	44-6

# WHEEL BRAKE

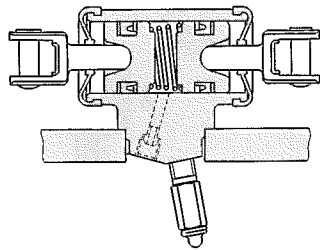

Section A—A

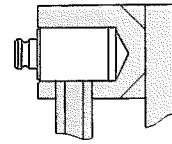

Section B—B

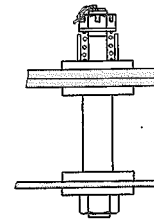
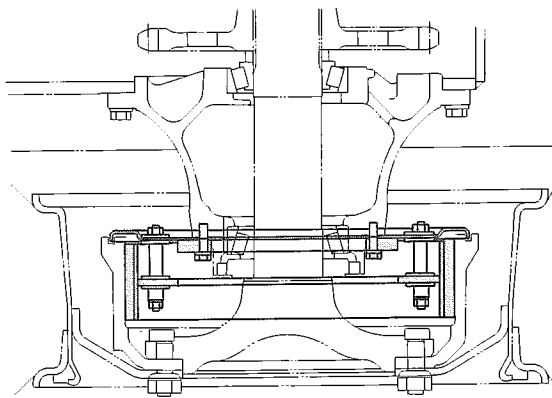

Section C—C

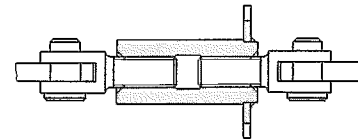

Section D—D

F23B060

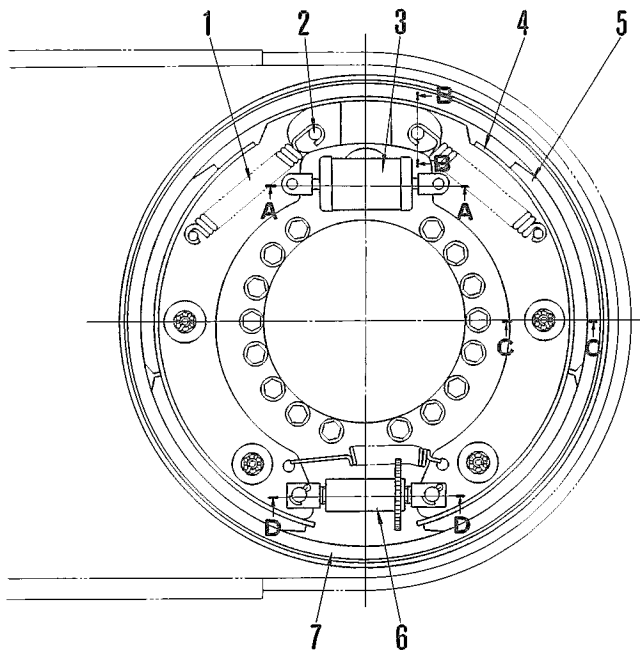

- 1. Return spring
- 2. Anchor pin
- 3. Wheel cylinder
- 4. Shoe
- 5. Lining
- 6. Adjuster
- 7. Brake drum

- When piston (3) and (5) move their whole stroke inlet valves (4) and (6) are completely opened. As a result, the air pressure in the spaces in the upper part and lower part, and in the right and left relay valves is the same as the air pressure in the air reservoir.
- Therefore, until the piston moves its full stroke down, the braking effect is controlled by the amount the brake pedal is depressed.

#### 5. Pedal released

##### Upper part

- If the pressure on the pedal is reduced, and the operating pressure is removed from the top of the piston, the piston moves up because of the air pressure at the bottom of the piston and the force of the piston return spring. As a result, the passage to exhaust port (9) is opened and the compressed air in the relay valve is released to the atmosphere.

##### Lower part

- If the pressure on the pedal is reduced, and the compressed air at the top of piston (5) is released, the air pressure at the bottom of piston (5) pushes piston (5) up. Exhaust port (10) is opened and the compressed air in the relay valve is released to the atmosphere.

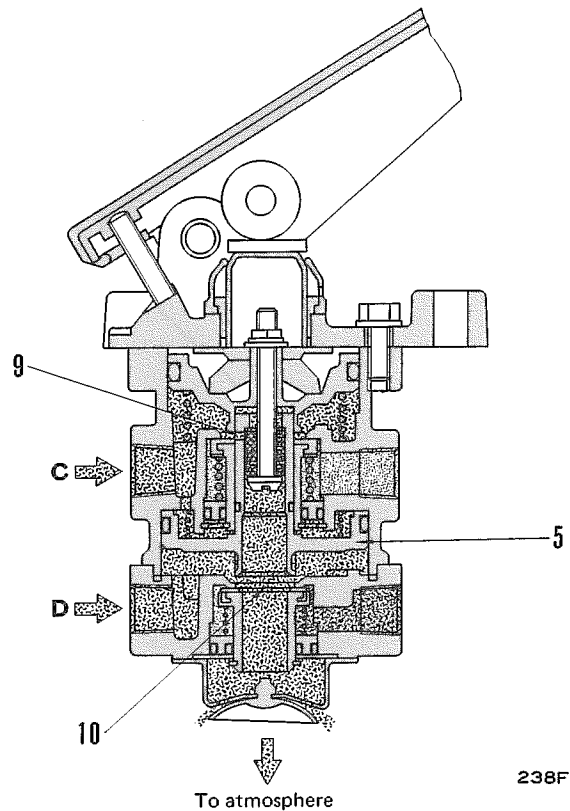

238F056

- When air pressure enters the air reservoir, inlet-exhaust valve (6) opens even when the pressure is low. Air and water then enter chamber A. The inlet-exhaust valve stops open until the pressure inside the air reservoir reaches the maximum pressure (until the governor is cut off).

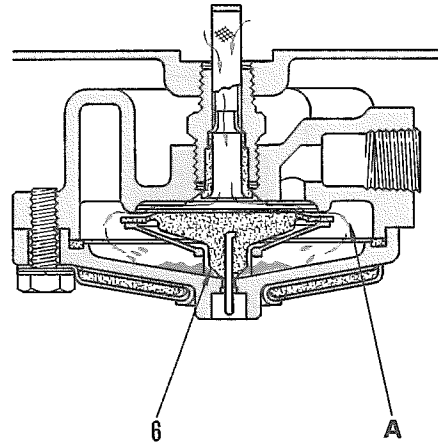

238F074

- When the pressure in the air reservoir and the pressure in chamber A are equal, the spring action of valve guide (5) closes inlet-exhaust valve (6).

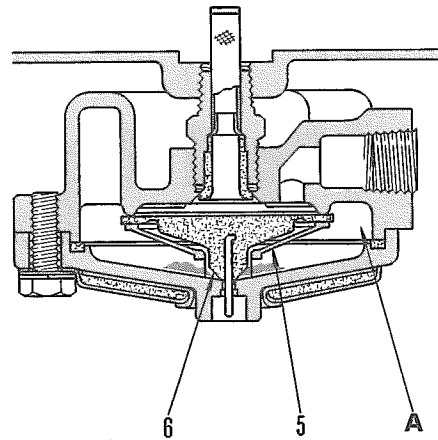

238F075

- When the pressure in the air reservoir drops, and the pressure in chamber A is about  $0.3 \text{ kg/cm}^2$ , inlet-exhaust valve (6) exhausts the air and water.

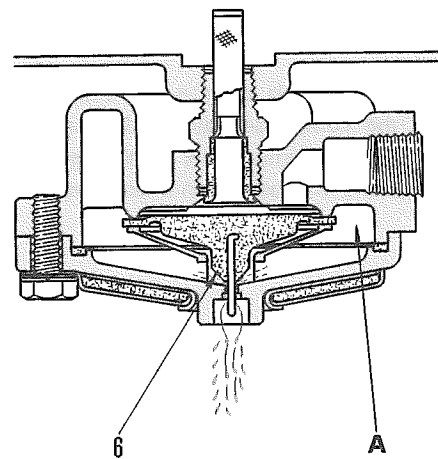

238F076

## BLEEDING AIR INSIDE BRAKE PIPING

- ★ Carry out air bleeding in pairs. One worker adds brake fluid to the brake tank by repeatedly depressing the brake pedal. The other bleeds air from the various parts of the brake.
- ★ Prepare extra brake fluid so that it will not run out during the work.



Bleed air with engine stopped.

1. Install vinyl tube to breather (7) and put the other end in a container half filled with brake fluid.
2. Depress the brake pedal a number of times, and loosen the breather plug with the pedal depressed. Tighten it before hydraulic pressure in the cylinder gives out. Repeat this process until air bubbles disappear from the brake fluid.
  - ★ Operate the brake pedal about 3 seconds per operation.

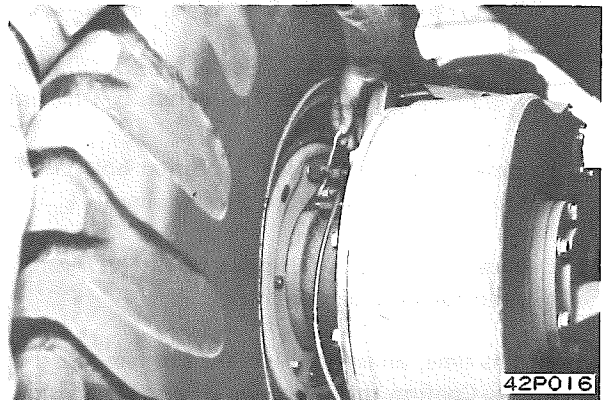
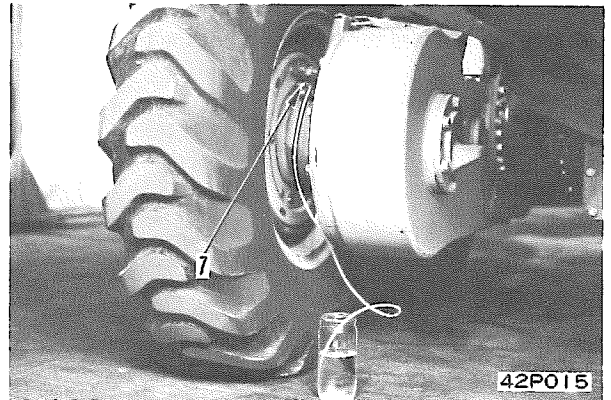

3. Bleed air from hydromaster plugs (8), (9) in that order according to the procedure in item 1 and 2.

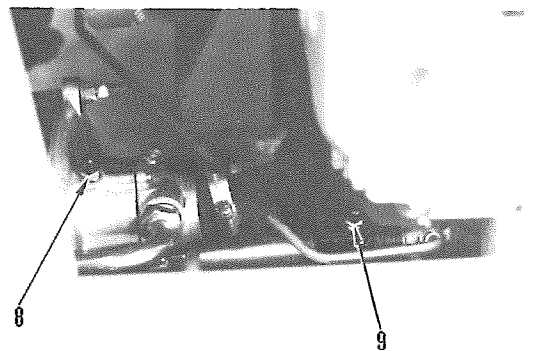

42P017

**DISC BRAKE** GD605A-3 (Serial No. 57001 – 57051)  
GD655A-3 (Serial No. 67001 – 67018)

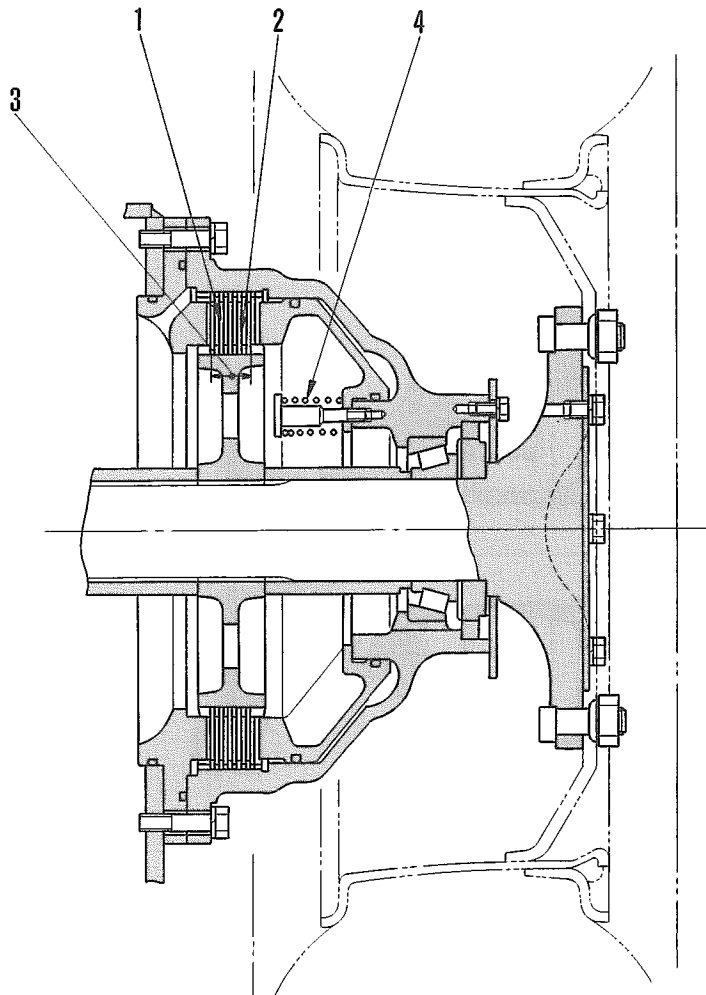

F23B110

Unit: mm

No.	Check Item	Criteria					Remedy
		Standard size		Repair limit			
1	Thickness of disc	3.8 ± 0.1		3.3 ± 0.1			Replace
		2.3 ± 0.1		35.9 ± 1.3			
2	Thickness of plate	38.9 ± 1.3		35.9 ± 1.3			
3	Total thickness of disc and plate	38.9 ± 1.3		35.9 ± 1.3			
		52		16.9 kg			
4	Return spring	Free length x O.D.	Installed length	Installed load	Free length	Installed load	
			52	16.9 kg	—	—	

### HYDRAULIC CONTROL PIPING (3/4)

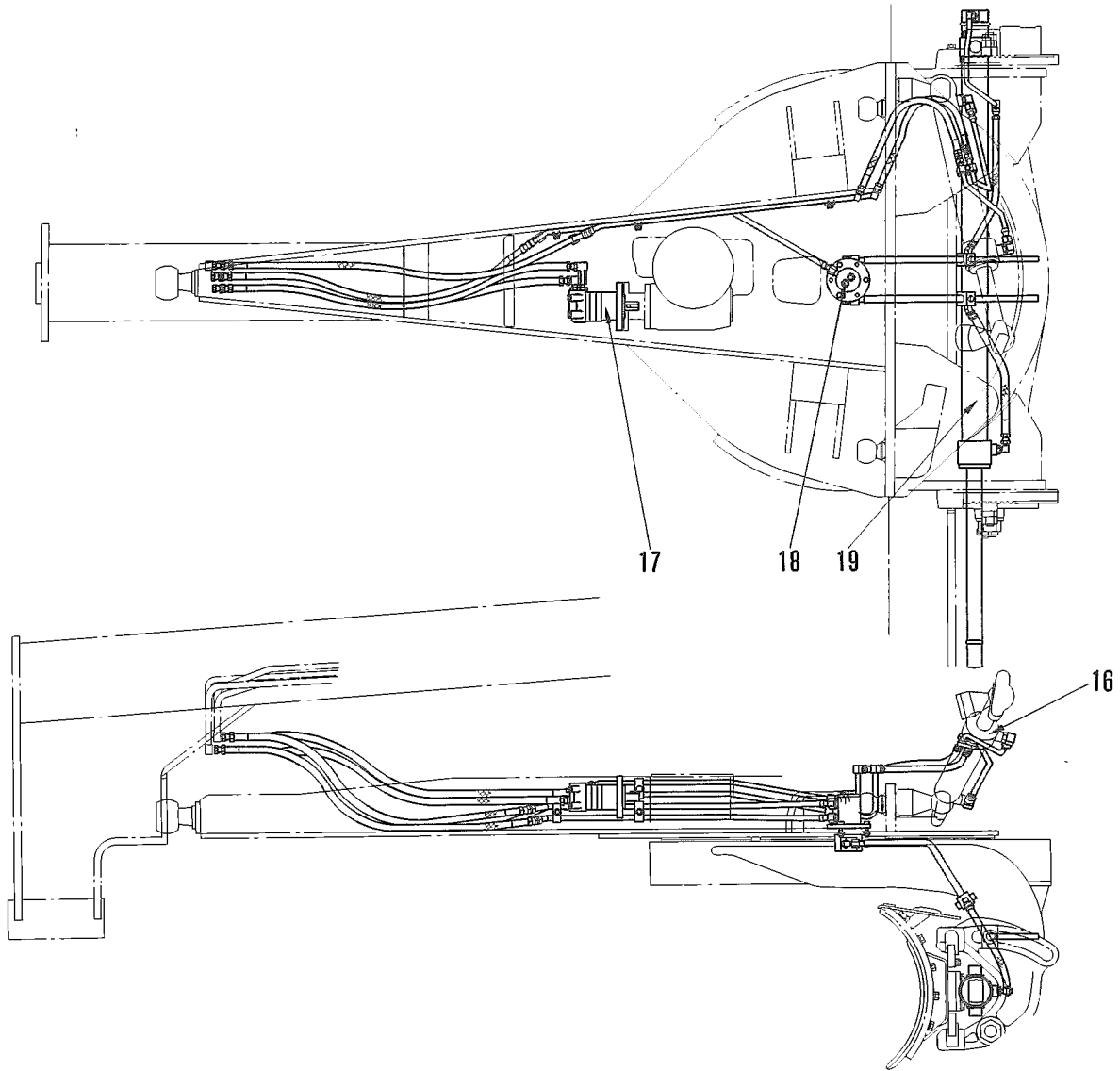

232F I 25

- 16. Drawbar shift cylinder
- 17. Hydraulic motor (Orbit motor)
- 18. Joint
- 19. Blade side shift cylinder

# HYDRAULIC PIPING DIAGRAM

GD605A-3 (Serial No. 57001 and up)  
GD655A-3 (Serial No. 67001 and up)

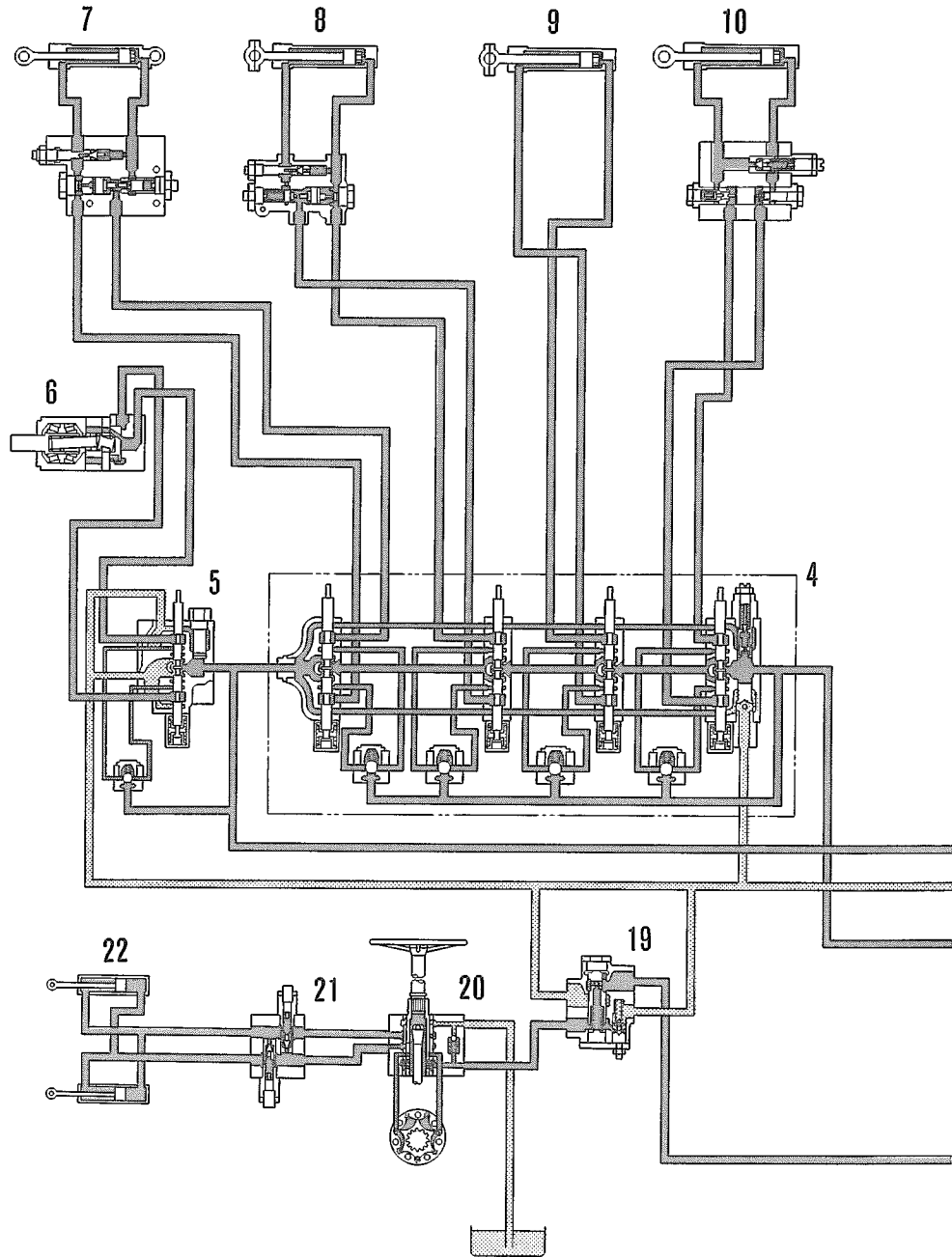



# CIRCLE ROTATION MOTOR

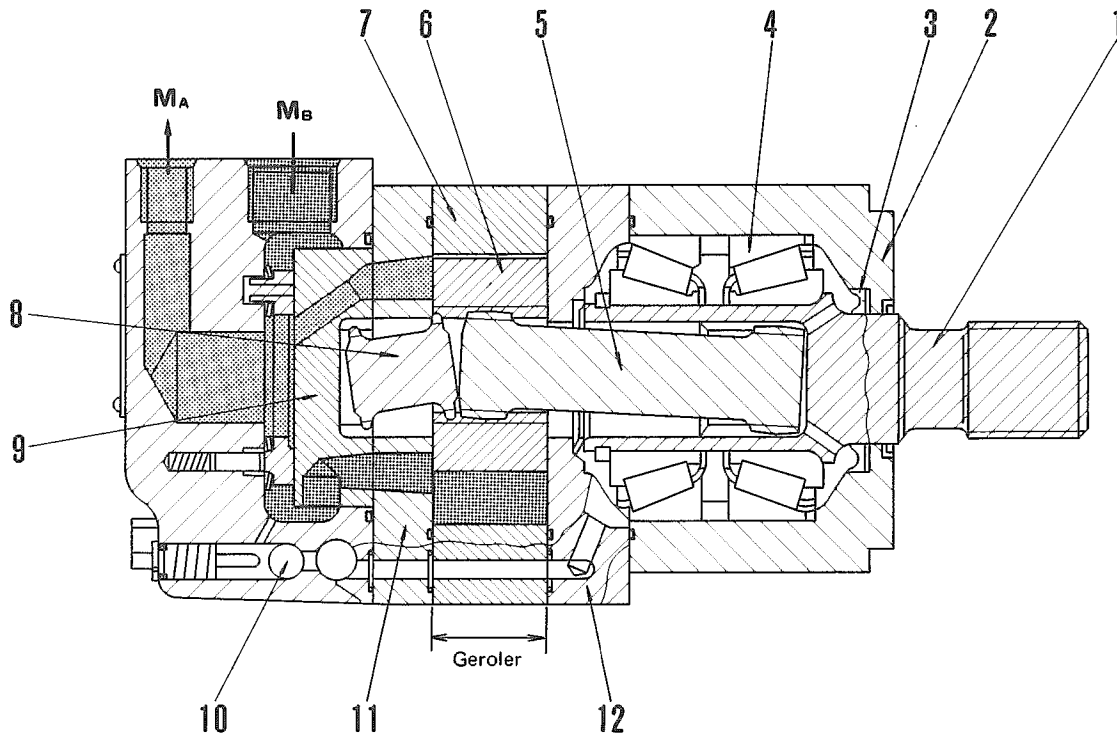

61F007A

- |                         |                           |
|-------------------------|---------------------------|
| 1. Output shaft         | 7. Geroler housing        |
| 2. Flange               | 8. Disc valve drive shaft |
| 3. Oil seal             | 9. Disc valve             |
| 4. Taper roller bearing | 10. Check valve           |
| 5. Main drive shaft     | 11. Valve plate           |
| 6. Star gear            | 12. Pump housing          |

Orbit motor is used for circle reverse motor; the machine is mounted with this motor on drawbar. Star gear (6) turns with high hydraulic pressure, thereby rotating output shaft (1) which turns together with the star gear (6) and the main drive shaft (5).

This output shaft is connected to circle-reverse gear case. Since star gear (6) engages with disc valve drive shaft (8), disc valve (9) also turns, thus charging the position where the hydraulic oil to Geroler housing (7) enters.

## HYDRAULIC PUMP TYPE

Sumitomo Eaton 2-125 type orbit motor

- |                                   |                       |
|-----------------------------------|-----------------------|
| ● Roller:                         | 37.5mm                |
| ● Theoretical oil quantity:       | 123 cc/rev.           |
| ● Rated speed:                    | 562 rprf              |
| ● Instantaneous maximum torque:   | 34.2 kgm              |
| ● Instantaneous maximum pressure: | 175kg/cm <sup>2</sup> |
| ● Weight:                         | 9.8 kg                |

**PERFORMANCE**

The performance of the operation lever is improved by cutting notches and grooves in the main valve spool.

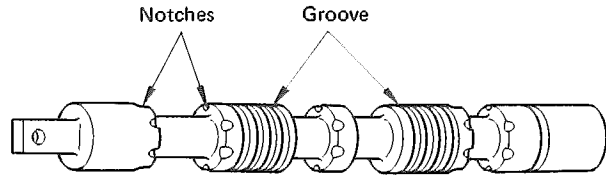

230F152

**Fine control**

Minor changes in the oil flow rate can be achieved by altering the spool stroke opening surface area during main valve spool operations. This ability to effect minor changes in flow rate is called FINE CONTROL.

If a spool without appropriate notches is operated by fine control, a large quantity of oil will flow when the port is opened, resulting in sudden jerking movement when starting or stopping the work equipment.

With proper notches in the spool, however, the flow rate can be controlled.

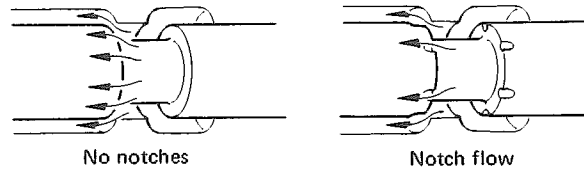

230F153

**Flow force**

When oil flows from the high pressure side to the low pressure side in the spool shown in the diagram at right, the gap between the valve body and the spool is restricted, resulting in increased flow at that section.

This increased oil flow rate results in a drop in pressure at that section, which means the pressure at AB is lower than at CD. This creates force F which acts in a direction to close the spool circuit.

This force is called the FLOW FORCE, and the action of this force effects the force required to operate the spool, making smooth operation more difficult, and even impeding automatic spool return after operation. To minimize the effects of this force, notches are formed as shown in the diagram at right, resulting in the oil flow passing out at a suitable angle.

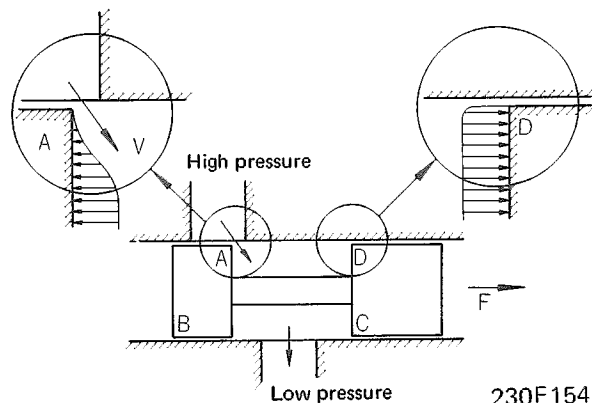

230F154

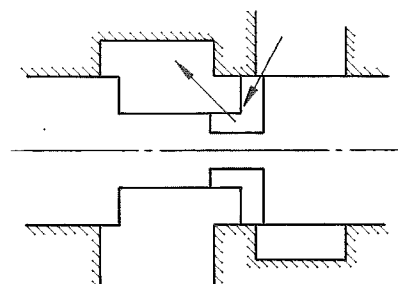

230F155

**PILOT CHECK VALVE**

GD605A-3 (Serial No. 57001 and up)  
GD655A-3 (Serial No. 67001 and up)

(For Power tilt)

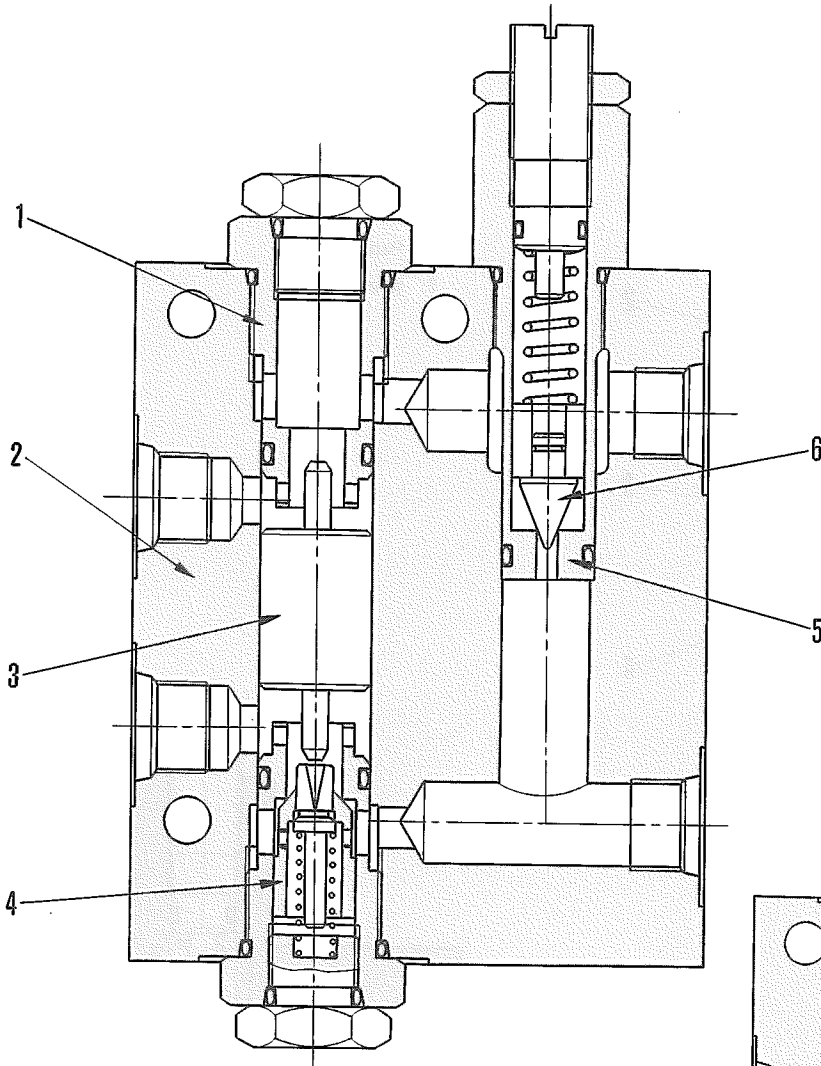

- 1. Valve
- 2. Body
- 3. Piston
- 4. Pilot check valve
- 5. Spool
- 6. Poppet

F23B096

The check valve with safety valve prevents hydraulic drift of the cylinder. At the same time, it protects the cylinder from abnormal pressure inside the cylinder caused by external force.

**OPERATION**

When lowering the blade, the oil from the pump enters chamber A<sub>2</sub> in the above hydraulic circuit diagram. The oil then flows to chamber B<sub>2</sub> rises the pressure at the bottom end, and pushes the cylinder. Because the cylinder is pushed, the oil in chamber B<sub>1</sub> passes through the pilot check valve and flows to chamber A<sub>1</sub>. When the pressure rises above 250 kg/cm<sup>2</sup>, the oil from chamber B<sub>1</sub> pushes the poppet and flows again to chamber B<sub>2</sub>.

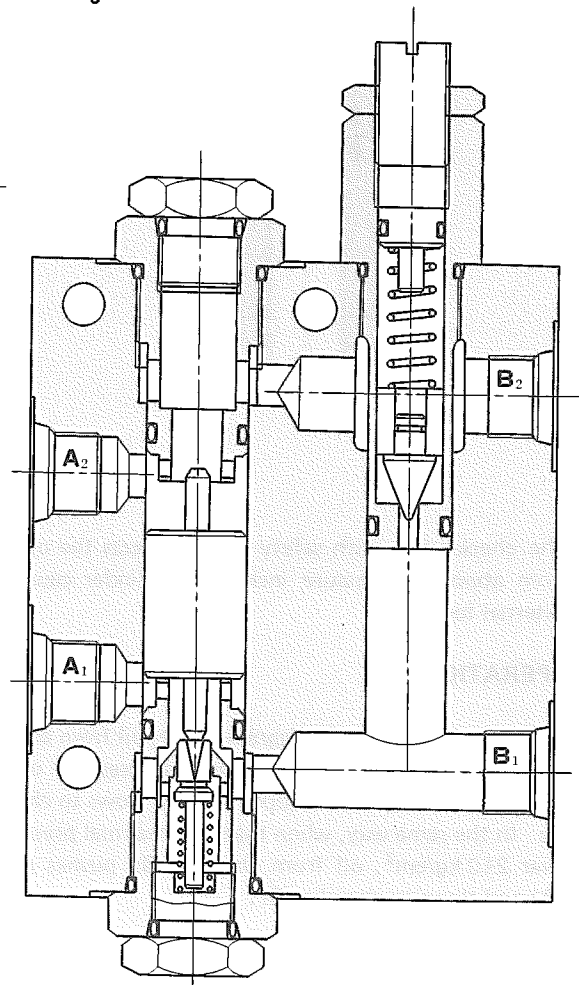

F23B097

# CHARGING BLADE ACCUMULATOR WITH GAS

**Special tool**

	Part number	Part name	Q'ty
A	792-610-1700	Charging assembly	1

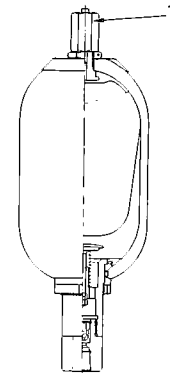

234F1144



Always use nitrogen when charging the accumulator with gas.

1. Remove plug (1) from the accumulator, then install charging assembly A.  
Size of joint for connecting accumulator: TV8
2. When installing the charging valve, tighten valve (2) fully and open valve (3) fully.
3. After installing charging valve assembly A, tighten valve (3) gradually and the charging pressure of the gas in the accumulator will be shown on pressure gauge (4).



Charging pressure:  $20 \begin{smallmatrix} +1 \\ 0 \end{smallmatrix} \text{ kg/cm}^2$

If pressure gauge (4) does not reach  $20 \text{ kg/cm}^2$ , loosen valve (2) gradually, and charge with gas from the cylinder until pressure gauge (4) reaches  $20 \text{ kg/cm}^2$ .

If the pressure gauge registers above  $20 \text{ kg/cm}^2$ , remove hose (5). Then gradually loosen valve (2) to release gas from the accumulator into the atmosphere and adjust to  $20 \text{ kg/cm}^2$ .

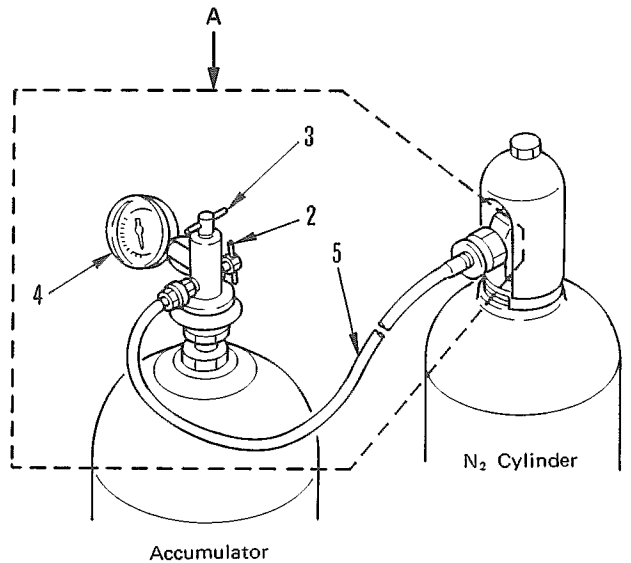

234F1145

Accumulator joint

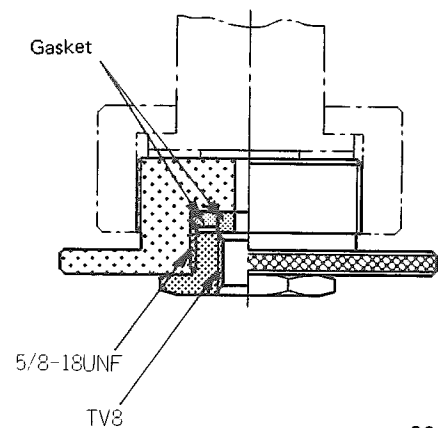

234F1146

## REMOVAL OF BLADE SIDE SHIFT CYLINDER ASSEMBLY



Start engine and operate lever to raise blade about 200 mm off the ground and support swing circle lower part with block.

1. Operate lever to fully extend piston rod (1) to push blade (2).

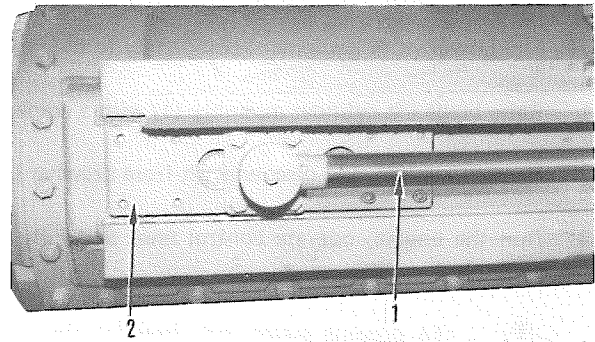

P23BB163

2. Temporarily sling cylinder piston rod (1) and disconnect bracket (3) from blade.
3. Remove bolt (4) and remove bracket.
4. Start engine and operate lever to fully retract piston rod.
5. Sling blade (2) and push it out to the position where cylinder can be removed.

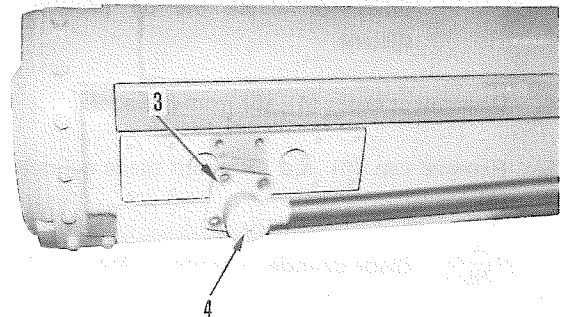

P23BB164

6. Disconnect hoses (5) and (6) from cylinder.

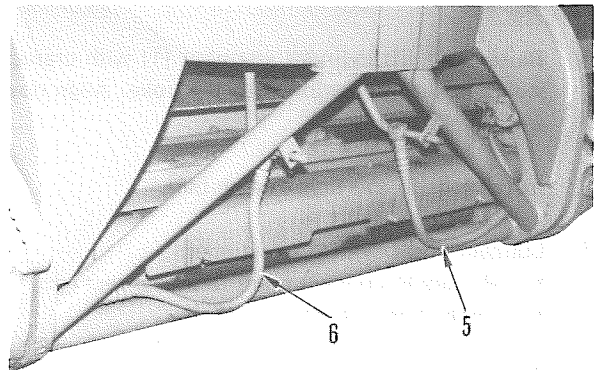

P23B03066

7. Put jack (1) to blade side shift cylinder assembly (7), remove bolt (8), remove washer (9) and dismount cylinder.



Blade side shift cylinder assembly:

Approx. 55 kg

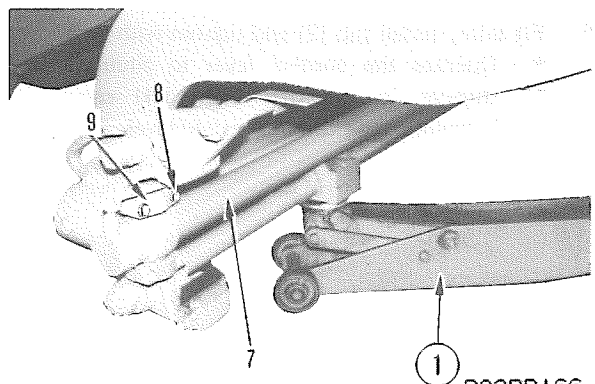

P23BB166

● 1-Spool control valve

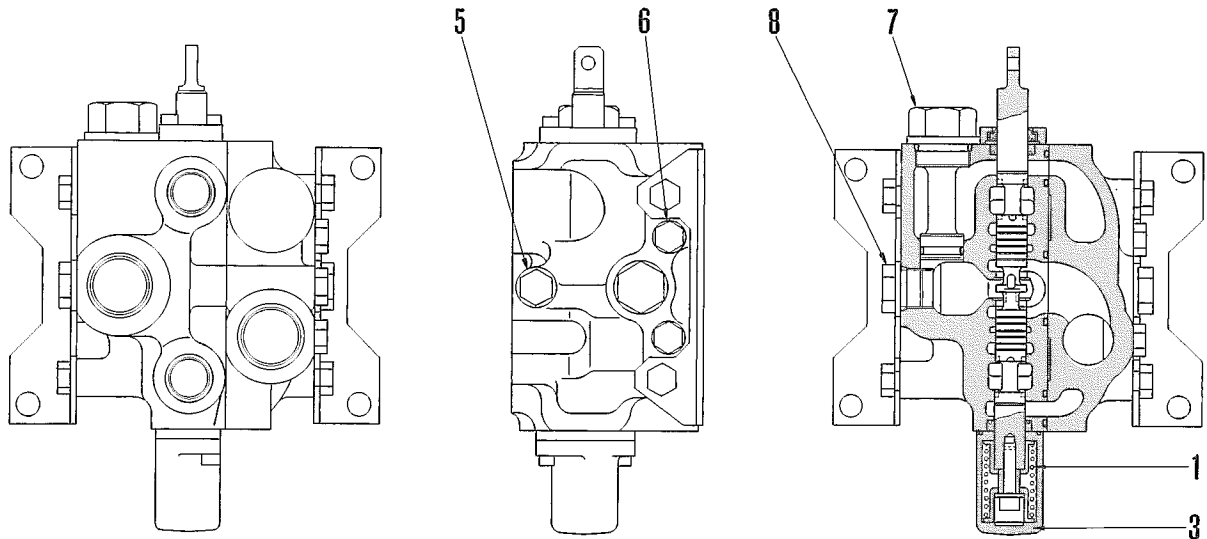

Section A-A

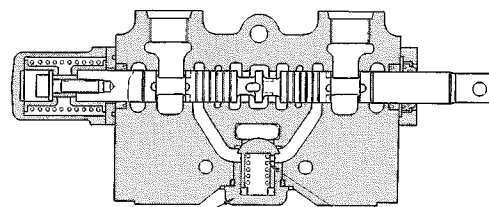
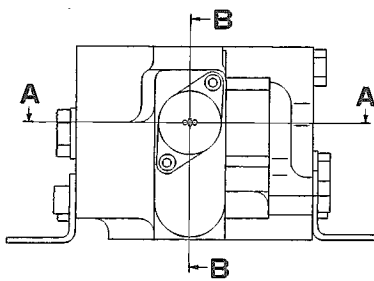

Section B-B

F23B111

Unit: mm

No.	Check Item	Criteria				Remedy	
		Standard size		Repair limit			
		Free length x O.D.	Installed length	Installed load	Free length	Installed load	
1	Return spring of spool		45.2	3.5 kg			Replace
2	Check valve spring		33.5	0.2 kg			
3	Plug tightening torque	3.5 ± 0.5 kgm					
4	Plug tightening torque	10.75 ± 1.75 kgm					
5	Body joint bolt tightening torque	9 ± 1 kgm					
6	Bolt tightening torque	6 ± 1 kgm					
7	Plug tightening torque	8.5 ± 1.5 kgm					
8	Plug tightening torque	7 ± 1 kgm					

**LIFTER**

GD605A-3 (Serial No. 57001 and up)  
GD655A-3 (Serial No. 67001 and up)

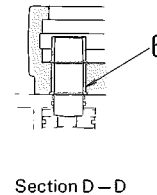
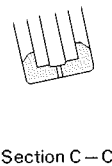
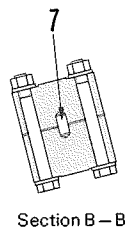
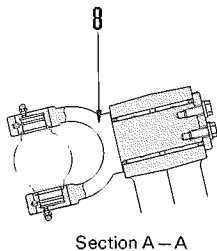
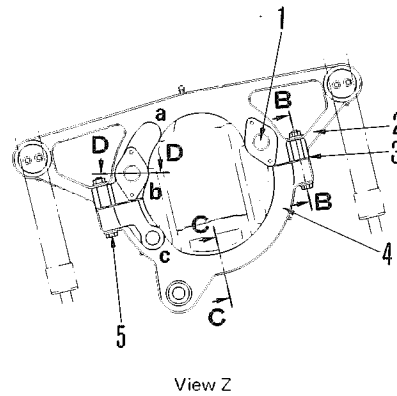
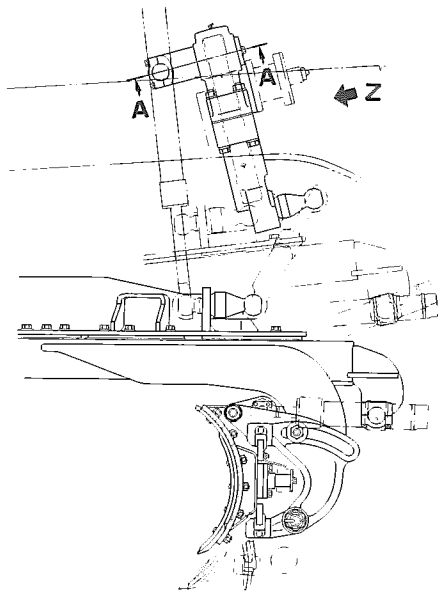

F23B03057

There is a cylinder installed in the lifter for moving the blade device. Brackets (2) and (4) are installed by the guide which is welded to the main frame. They can be revolved by revolving the guide by extracting a pin (1) controlled from the operator's seat. There are five insertion holes altogether for the pin (1) stopping revolution. Holes (a) and (c) are used for the blade to make a bank cut or shoulder cut to left or right. (b) is used for ditch digging, etc., when the digging position is midway to the bank cut position.

This (c) gets used much more than other holes and a bushing (6) is used in it to make the clearance between the pin and the hole at a minimum. (This clearance amplifies the up and down movement of the blade). Also, the clearance between the bracket and the guide welded to the frame can be adjusted with shims (3). Pin (7) combined with bolt (5) tightening force prevents bracket up and down slippage.

- 1. Pin
- 2. Bracket (upper)
- 3. Shim
- 4. Bracket (lower)
- 5. Bolt
- 6. Bushing
- 7. Pin
- 8. Yoke

## HYDRAULIC CONTROL LINKAGE

GD605A-3 (Serial No. 57001 and up)  
GD655A-3 (Serial No. 67001 and up)

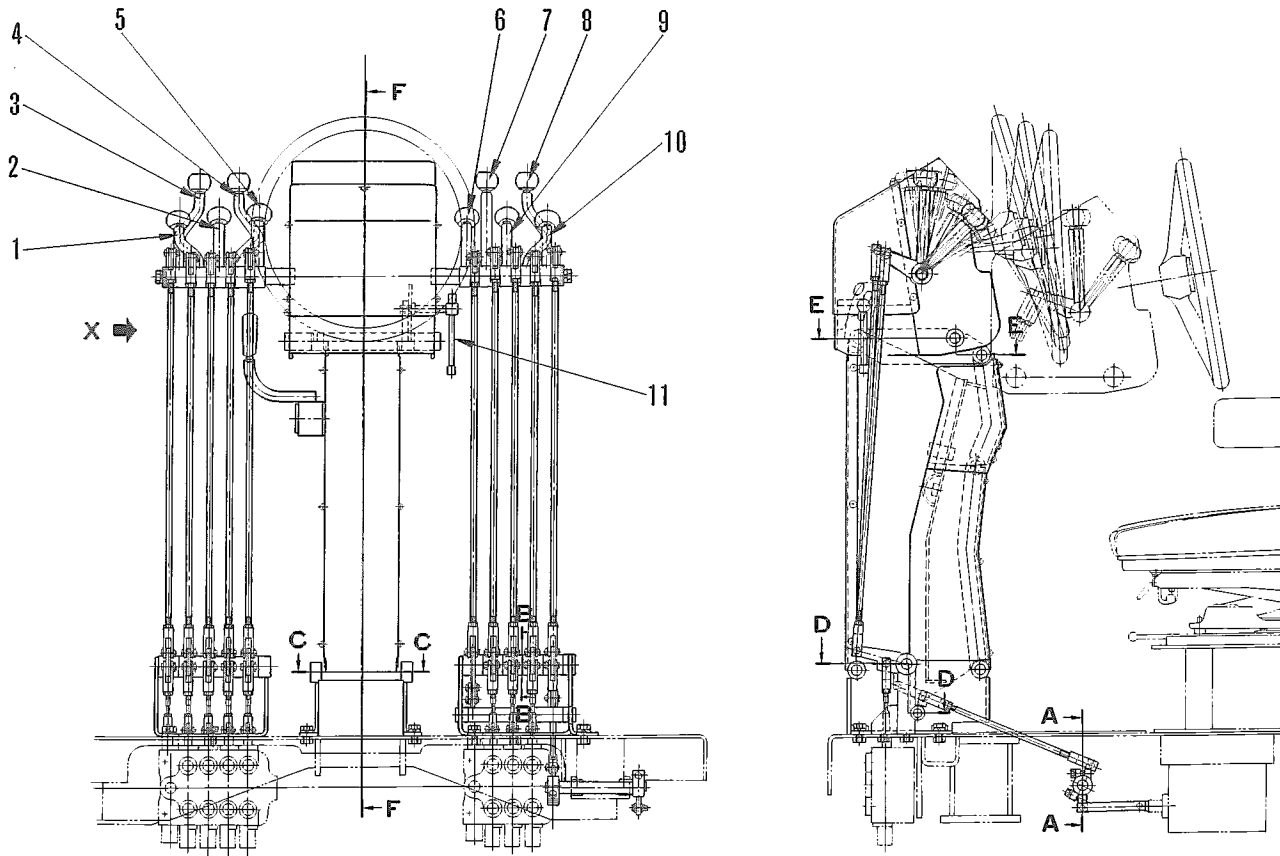

F23AB207

● **Adjusting the steering wheel column and the console box**

Turn tilt lever (11) counterclockwise to unlock the steering wheel column, set the column to the desired position, and lock the column again by tightening the tilt lever. Nonstep adjustment is possible in a range of  $7^\circ$  up and down from the standard set position (tilt angle).

● **Console box angling mechanism**

Pull angling lever (14) to release the dowel of slider (19) from its hole, and the angle of the console box can be adjusted in four stages.

These adjustments allow the operator to get the optimum set positions of the steering wheel and work-equipment control lever.

1. Blade lift (R.H.) lever
2. Leaning lever
3. Scarifier lever (If equipped)
4. Articulate lever
5. Drawbar shift lever
6. Circle reverse lever
7. Power tilt lever
8. Ripper lever (If equipped)
9. Blade shift lever
10. Blade lift (L.H.) lever
11. Tilt lever

- 4. **Bolt, Washer**  
Remove bolt (6) and washer (7) from shaft of hydraulic motor assembly.
- 5. **Plate**  
Remove plate (8).

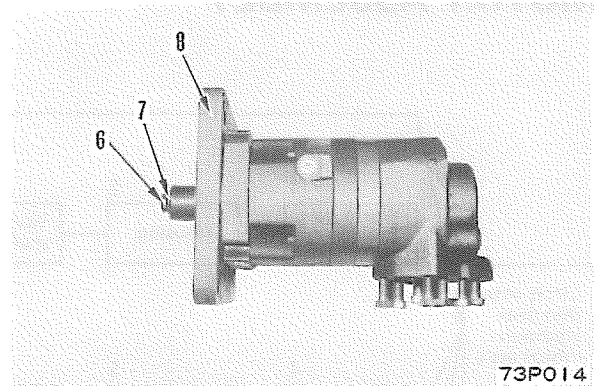

- 6. **Cover**  
Remove cover (9).
- 7. **Housing**  
Remove housing (11) and shim (12) from case (10).

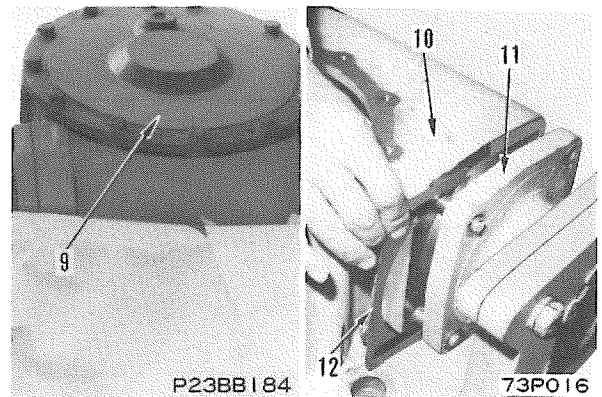

- 8. **Worm gear, Bearing assembly**
  - 1) Remove worm gear, bearing assembly (13).
  - 2) Remove bearing (15) from shaft (14).
- 9. **Worm wheel shaft assembly**
  - 1) Remove wheel shaft (16).
  - 2) Remove lock plate and remove gear (18) from shaft (17).

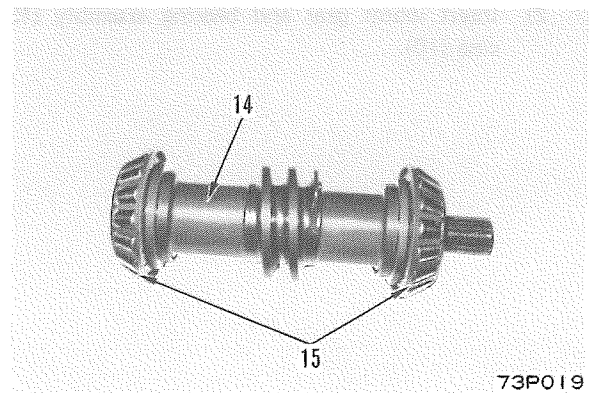
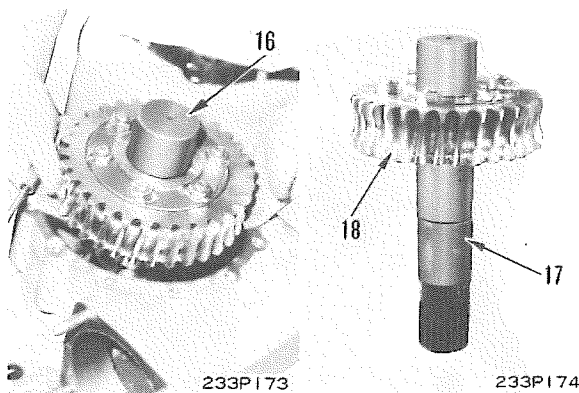
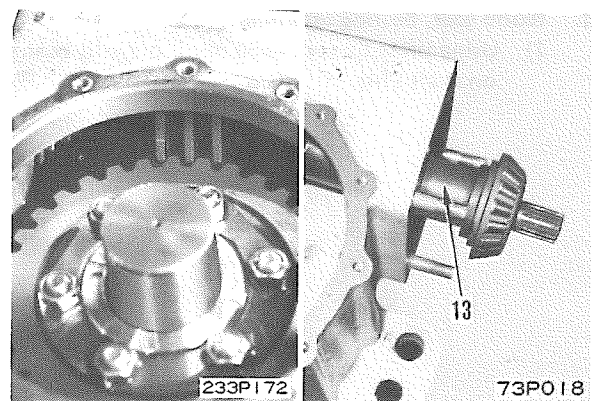

GD605A-3 (Serial No. 57001 and up)

GD655A-3 (Serial No. 67001 and up)

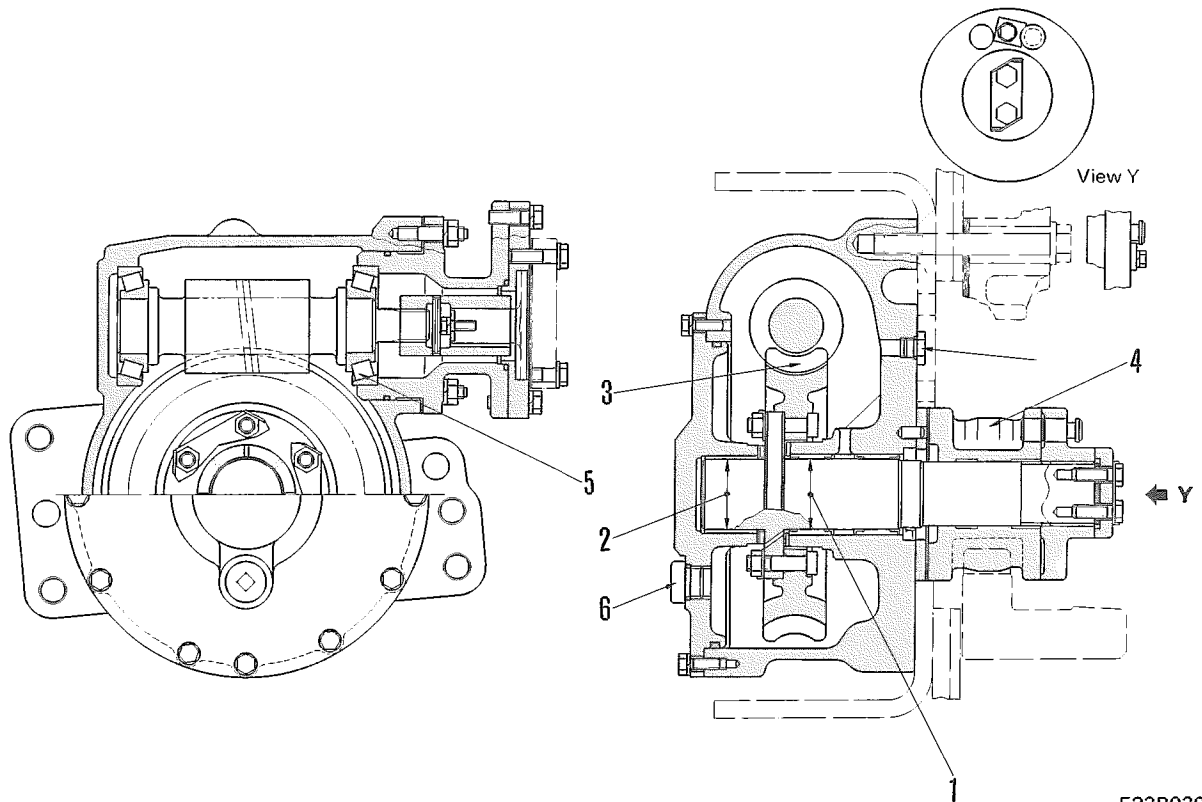

F23B03062

Unit: mm

No.	Check Item	Criteria				Remedy	
		Standard size	Tolerance		Standard clearance		Clearance limit
	Shaft		Hole				
1	Clearance between worm shaft and bushing	65	-0.030 -0.060	+0.045 0	0.030 – 0.105	0.3	Replace bushing
2	Clearance between worm shaft and bushing	65	+0.035 +0.005	+0.226 +0.069	0.034 – 0.221	0.3	
3	Backlash between worm wheel and worm	Standard clearance		Clearance limit		2.0	Replace worm wheel
		0.3 – 0.4					
4	Wear of pinion gear	Standard clearance		Repair limit		20	Replace
		25					
5	Preload of worm shaft bearing	Starting torque: 0.3 – 0.8 kgm (when worm wheel is not engaged)				Adjust shim	
6	Filler plug tightening torque	11 ± 1.5 kgm					
7	Drain plug tightening torque	4 ± 0.5 kgm					

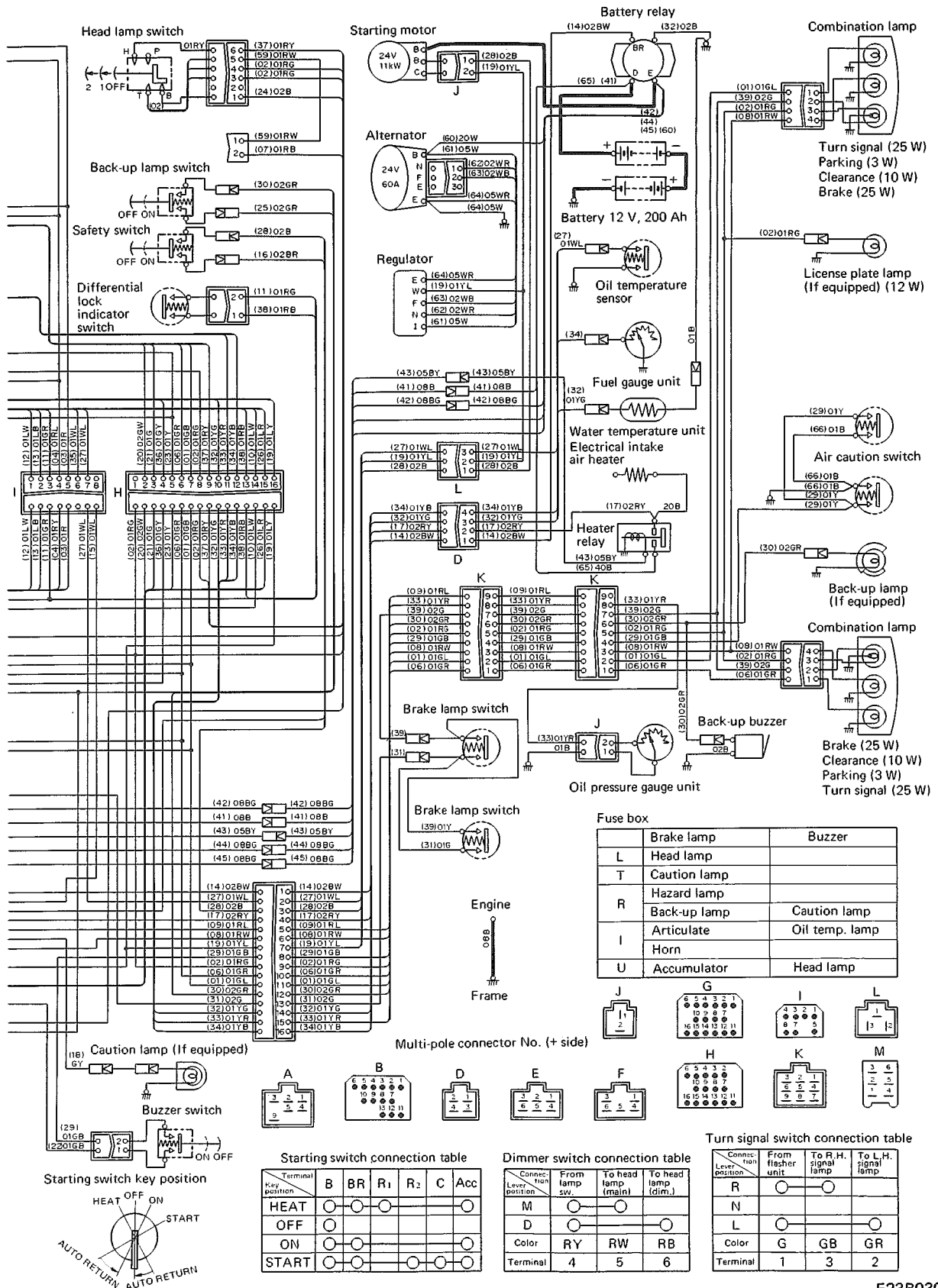

CLICK HERE TO **DOWNLOAD** THE COMPLETE MANUAL

- Thank you very much for reading the preview of the manual.
- You can download the complete manual from: [www.heydownloads.com](http://www.heydownloads.com) by clicking the link below



- Please note: If there is no response to CLICKING the link, please download this PDF first and then click on it.

CLICK HERE TO **DOWNLOAD** THE COMPLETE MANUAL