

**KOMATSU**

# SHOP MANUAL

**FD100/115-7**

**FD135/150E/160E-7**

MACHINE MODEL

**FD100/115-7**

**FD135/150E/160E-7**

SERIAL No.

**6001 and up**

**6001 and up**

ENGINE

**6BG1T**

**6BG1T**

CLICK HERE TO **DOWNLOAD** THE COMPLETE MANUAL

- Thank you very much for reading the preview of the manual.
- You can download the complete manual from: [www.heydownloads.com](http://www.heydownloads.com) by clicking the link below



- Please note: If there is no response to CLICKING the link, please download this PDF first and then click on it.

CLICK HERE TO **DOWNLOAD** THE COMPLETE MANUAL

### USE SUITABLE TOOLS

- Always use tools that are suited for inspection and maintenance.  
It is extremely dangerous to use broken tools or tools designed for another purpose.



HBZ00341

### REPLACE SAFETY CRITICAL PARTS PERIODICALLY

- Even if no abnormality is found, always replace safety critical parts periodically.  
As time passes, these parts deteriorate and may cause fire or failure in the work equipment system.
- However, if these parts show any abnormality before the replacement interval has passed, they should be repaired or replaced immediately.

### PRECAUTIONS WITH HIGH TEMPERATURE COOLANT

- Immediately after using the lift truck, the engine coolant is at high temperature and high pressure. Do not remove the radiator cap under these conditions.  
Hot water may spurt out and cause burns.
- When removing the radiator cap, turn it slowly to release the internal pressure.
- When checking the coolant level, stop the engine and wait for the engine and radiator to cool down before checking. For lift trucks equipped with a subtank or reservoir, check the level in the subtank.
- When adding water on lift trucks equipped with a sub-tank, add the water to the subtank.

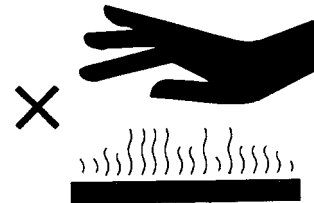

HBZ00342

## 20. TESTING AND ADJUSTING

Service data .....	20- 2
Engine .....	20- 4
Air cleaner .....	20- 6
Adjusting of valve clearance .....	20- 7
Tightening torque of cylinder head.....	20- 8
Fuel injection timing .....	20- 9
Adjusting accelerator pedal.....	20-11
Adjusting brake/inching pedal .....	20-12
Adjusting parking brake .....	20-13
TORQFLOW transmission case.....	20-14
Differential case .....	20-15
Bleeding air .....	20-16
Hydraulic tank .....	20-17
Measuring hydraulic drift of lift cylinder, tilt cylinder .....	20-18
Oil and greasing chart.....	20-19
Lubricant list.....	20-20
Check items for each equipment.....	20-21

## ADJUSTING ACCELERATOR PEDAL

### 1. Pedal height (from floor plate)

Adjust with turnbuckle (1).

Pedal height h	137 mm (5.4 in)
----------------	-----------------

### 2. Stroke

Adjust with stopper bolt (2). (※ : 61 mm (2.4 in))

Stroke	57 mm (2.2 in)
--------	----------------

### 3. Lever on engine side

After installing the link, depress the pedal to the stroke end. At this time, adjust stopper bolt (2) so that the lever on the engine side will open fully.

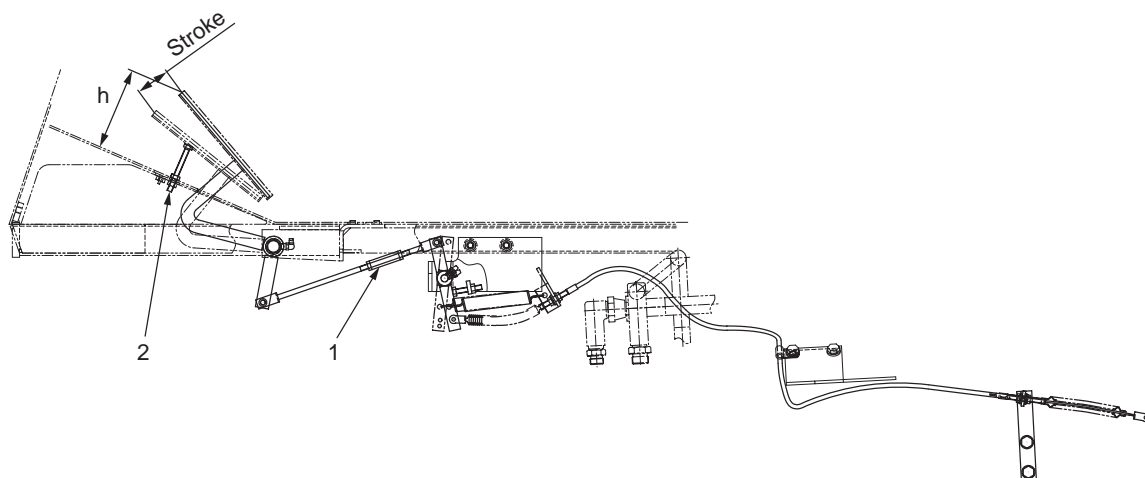
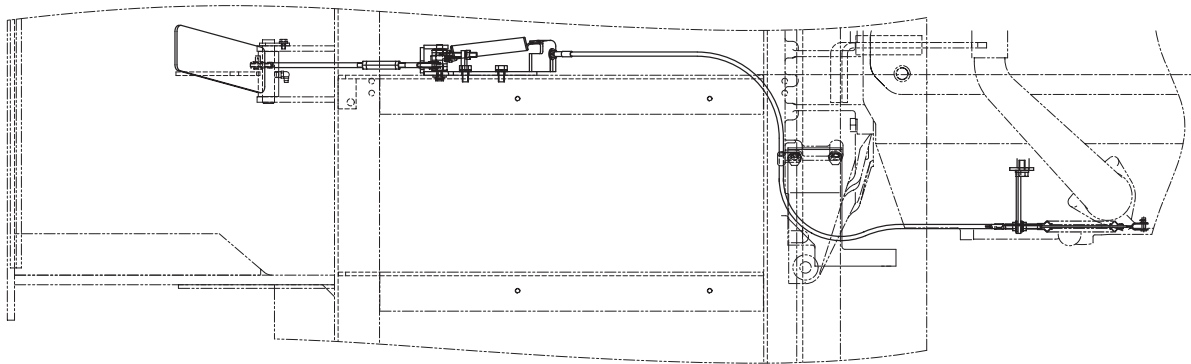

★ Adjust the idling speed of the engine with turnbuckle (1).





## CHECK ITEMS FOR EACH EQUIPMENT

Note: The numbers in the inspection item column corresponds to the numbers in “Special Self Inspection Record Table (UCE-02)”.

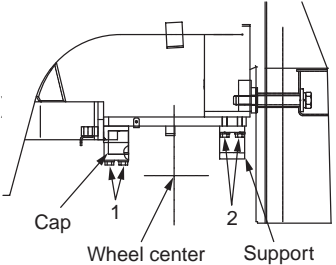
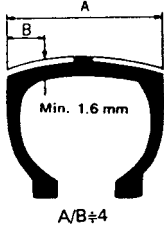
Com- ponent	Inspection item	Nature of inspection				
Engine	1. Ease of starting, abnormal noise	<ul style="list-style-type: none"> <li>• Pull the parking brake, place the directional lever at neutral, then start the engine and check as follows.                             <ol style="list-style-type: none"> <li>1. Does the engine start smoothly?</li> <li>2. Is there any abnormal noise?</li> <li>3. Does the glow plug work properly?</li> <li>4. Do the accelerator pedal and levers move smoothly</li> </ol> </li> </ul>				
	2. Running condition, exhaust gas	<ul style="list-style-type: none"> <li>• Depress the accelerator pedal and check as follows.                             <ol style="list-style-type: none"> <li>1. Does the engine speed rise smoothly?</li> <li>2. Is the exhaust gas color correct?                                     <table border="1" data-bbox="711 890 1235 974" style="margin-left: 40px; width: 100%;"> <tr> <td style="width: 60%;">When idling</td> <td>No color</td> </tr> <tr> <td>When pedal is depressed</td> <td>Thin black color</td> </tr> </table> </li> <li>3. Is the exhaust noise correct?</li> <li>4. Is there any leakage of exhaust gas?</li> </ol> </li> </ul>	When idling	No color	When pedal is depressed	Thin black color
	When idling	No color				
	When pedal is depressed	Thin black color				
3. Engine speed	<ul style="list-style-type: none"> <li>• After warming up the engine, check as follows.                             <ol style="list-style-type: none"> <li>1. Idling speed                                     <table border="1" data-bbox="711 1226 1235 1318" style="margin-left: 40px; width: 100%;"> <tr> <td style="width: 40%;">FD100/115 FD135/150E FD160E</td> <td>600–700 rpm</td> </tr> </table> </li> <li>2. Max. speed                                     <table border="1" data-bbox="711 1394 1235 1486" style="margin-left: 40px; width: 100%;"> <tr> <td style="width: 40%;">FD100/115 FD135/150E FD160E</td> <td>2,350–2,450 rpm</td> </tr> </table> </li> </ol> </li> </ul>	FD100/115 FD135/150E FD160E	600–700 rpm	FD100/115 FD135/150E FD160E	2,350–2,450 rpm	
FD100/115 FD135/150E FD160E	600–700 rpm					
FD100/115 FD135/150E FD160E	2,350–2,450 rpm					
4. Air cleaner	<ul style="list-style-type: none"> <li>• Check the air cleaner as follows                             <ol style="list-style-type: none"> <li>1. Check the air cleaner for cracks, deformation</li> <li>2. Check the air cleaner mount for looseness</li> <li>3. Check the element for dirt or damage</li> <li>★ For details of the method of cleaning and replacing the element, see TESTING AND ADJUSTING.</li> </ol> </li> </ul>					

Component	Inspection item	Nature of inspection																	
Travel system	27. Front axle	1. Deformation, cracks, damage Check visually or use the crack detector method. (Be particularly careful to check the weld and area around the mounting bolts with the main frame.) 2. Loose mounting bolts Tightening torque for bolts mounting to frame <hr/>  1,961–2,452 Nm {200–250 kgm}																	
	28. Rear axle	1. Deformation, cracks, damage Check visually or use the crack detector method. 2. Play of center pin (clearance from bushing) 3. Loose cap, support mounting bolts <hr/> Bolts 1,2  490–608 Nm {50.0–62.0 kgm} 																	
	29. Tire	1. Inflation pressure Unit: MPa {kgcm <sup>2</sup> } <table border="1" data-bbox="685 1066 1146 1318"> <thead> <tr> <th>Model</th> <th>Front wheel</th> <th>Rear wheel</th> </tr> </thead> <tbody> <tr> <td>FD100</td> <td>0.73 {7.5}</td> <td>0.73 {7.5}</td> </tr> <tr> <td>FD115</td> <td>0.68 {7.0}</td> <td>0.68 {7.0}</td> </tr> <tr> <td>FD135</td> <td>0.66 {6.75}</td> <td>0.66 {6.75}</td> </tr> <tr> <td>FD150E</td> <td>0.76 {7.75}</td> <td>0.76 {7.75}</td> </tr> <tr> <td>FD160E</td> <td>0.68 {7.0}</td> <td>0.68 {7.0}</td> </tr> </tbody> </table> 2. Cracks, damage to tread, side wall If the damage is serious, replace the tire. 3. Depth of groove (wear amount) For pneumatic tires, measure the depth of the groove at a point 1/4 of the tread width and check that it is at least 1.6 mm.  4. Abnormal wear Check for uneven or stepped wear. 5. Pieces of metal stuck in tire	Model	Front wheel	Rear wheel	FD100	0.73 {7.5}	0.73 {7.5}	FD115	0.68 {7.0}	0.68 {7.0}	FD135	0.66 {6.75}	0.66 {6.75}	FD150E	0.76 {7.75}	0.76 {7.75}	FD160E	0.68 {7.0}
Model	Front wheel	Rear wheel																	
FD100	0.73 {7.5}	0.73 {7.5}																	
FD115	0.68 {7.0}	0.68 {7.0}																	
FD135	0.66 {6.75}	0.66 {6.75}																	
FD150E	0.76 {7.75}	0.76 {7.75}																	
FD160E	0.68 {7.0}	0.68 {7.0}																	

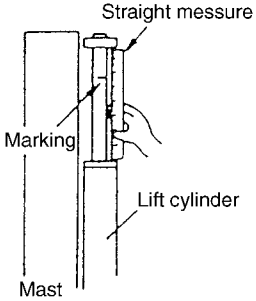
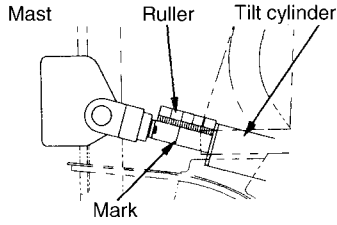
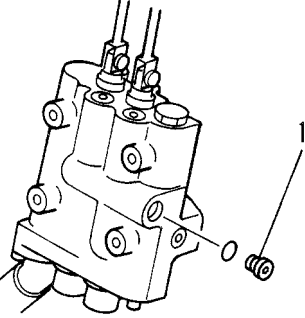
Component	Inspection item	Nature of inspection								
Hydraulic system	68. Tilt cylinder	1. Actuation, oil leakage 2. Dents, cracks, curvature, scratches on rod 3. Tightening torque for mounting bolts  <table border="1" style="width: 100%; border-collapse: collapse;"> <tr> <td style="text-align: center;"> kgm</td> <td style="text-align: center;">54–123 Nm {5.5–12.5 kgm}</td> </tr> </table>	 kgm	54–123 Nm {5.5–12.5 kgm}						
	 kgm	54–123 Nm {5.5–12.5 kgm}								
	70. Attachment cylinders	1. Actuation, oil leakage 2. Dents, cracks, curvature, scratches on rod 3. Looseness of mounting bolts								
	71. Hydraulic drift of lift cylinder, tilt cylinder	<p>Load the forks with the maximum payload, set the mast perpendicular, raise the forks approx. 1 m from the ground, then check that the hydraulic drift is within the specified value given below.</p> <table border="1" style="width: 100%; border-collapse: collapse;"> <tr> <td rowspan="2" style="text-align: center;">Hydraulic drift of lift cylinder</td> <td style="text-align: center;">When measured at fork</td> <td style="text-align: center;">Within 100 mm (4 in) (for 15 min)</td> </tr> <tr> <td style="text-align: center;">When measured at cylinder</td> <td style="text-align: center;">Within 50 mm (4 in) (for 15 min)</td> </tr> <tr> <td style="text-align: center;">Hydraulic drift of lift cylinder</td> <td colspan="2" style="text-align: center;">Within 40 mm (1.6 in) (for 15 min)</td> </tr> </table> <p><b>Adjustment:</b> Replace the control valve, cylinder packing</p> <div style="display: flex; justify-content: space-around; align-items: center;">   </div>	Hydraulic drift of lift cylinder	When measured at fork	Within 100 mm (4 in) (for 15 min)	When measured at cylinder	Within 50 mm (4 in) (for 15 min)	Hydraulic drift of lift cylinder	Within 40 mm (1.6 in) (for 15 min)	
	Hydraulic drift of lift cylinder	When measured at fork		Within 100 mm (4 in) (for 15 min)						
When measured at cylinder		Within 50 mm (4 in) (for 15 min)								
Hydraulic drift of lift cylinder	Within 40 mm (1.6 in) (for 15 min)									
72. Directional control valve (1)	1. Actuation, oil leakage  2. Loose mounting bolts									
73. Directional control valve (2)	<p><b>Measure relief pressure</b></p> <ol style="list-style-type: none"> <li>1) Install an oil pressure gauge to relief pressure measurement port (1).</li> <li>2) Raise the forks to the maximum lifting height, measure the oil pressure when the oil is relieved, and check that it is within the specified pressure.</li> </ol> <p style="text-align: right;">Unit: MPa {kgcm<sup>2</sup>}</p> <table border="1" style="width: 100%; border-collapse: collapse;"> <tr> <td style="text-align: center;">Relief set pressure</td> <td style="text-align: center;">21.6 {220}</td> </tr> </table> <div style="text-align: right;">  </div>	Relief set pressure	21.6 {220}							
Relief set pressure	21.6 {220}									

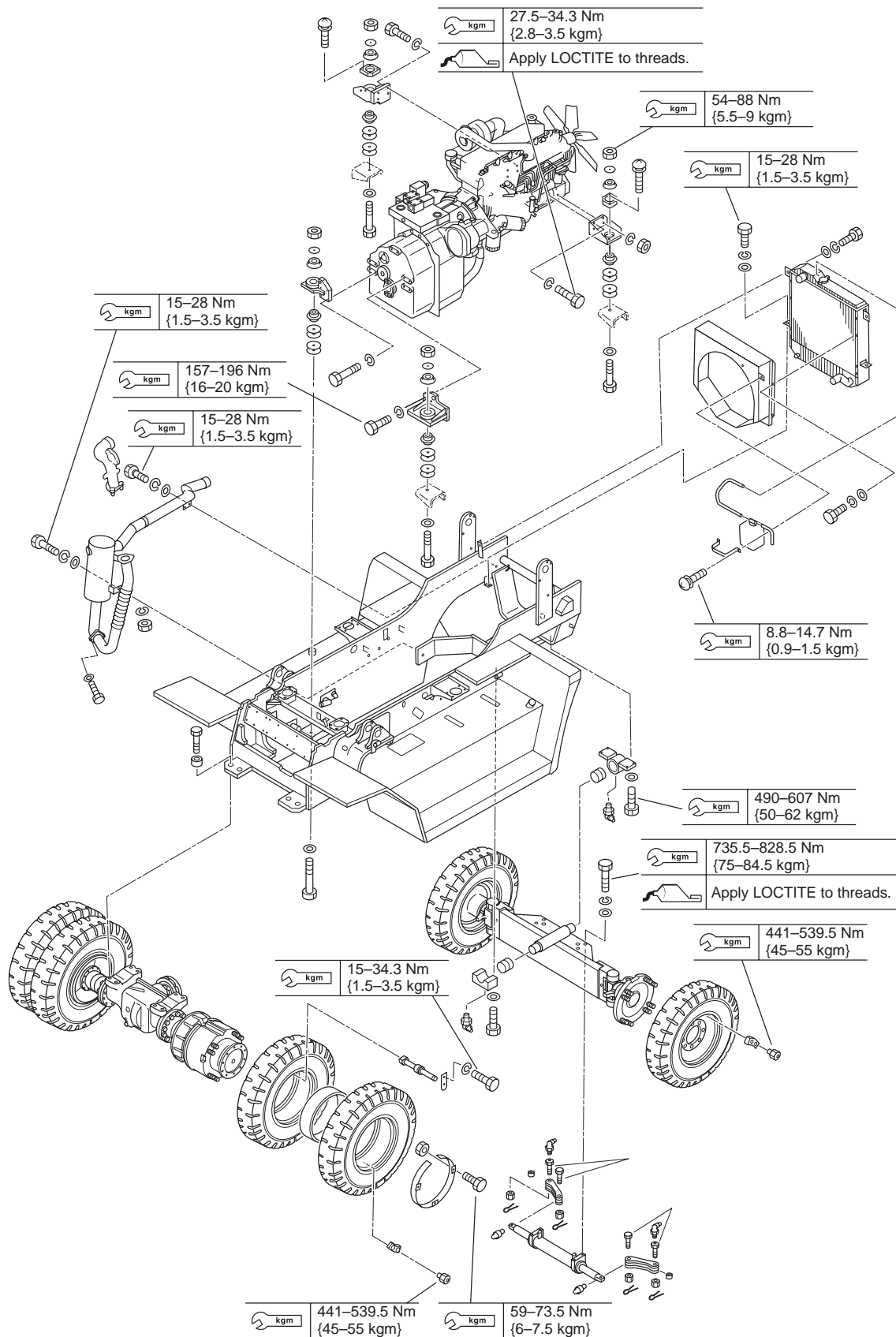

## WORK EQUIPMENT CONTROL LEVER

1. Connect the yoke portion of link (A) and the control valve with pin (F). Insert a cotter pin into the pin and bend it to hold in position. (Link length: 484 mm)
2. Align both the lift and tilt levers with bracket (B), insert support pin (C), then tighten bolt (D).
3. Connect the lever yoke and the end of link (A) with a pin. Insert a cotter pin into the pin and bend it to hold in position.
4. Install bracket (B) of the lever to the bracket at the chassis end with the bolt.
5. Lever travel

	S1	S2
Lift lever	126	126
Tilt lever	130	130

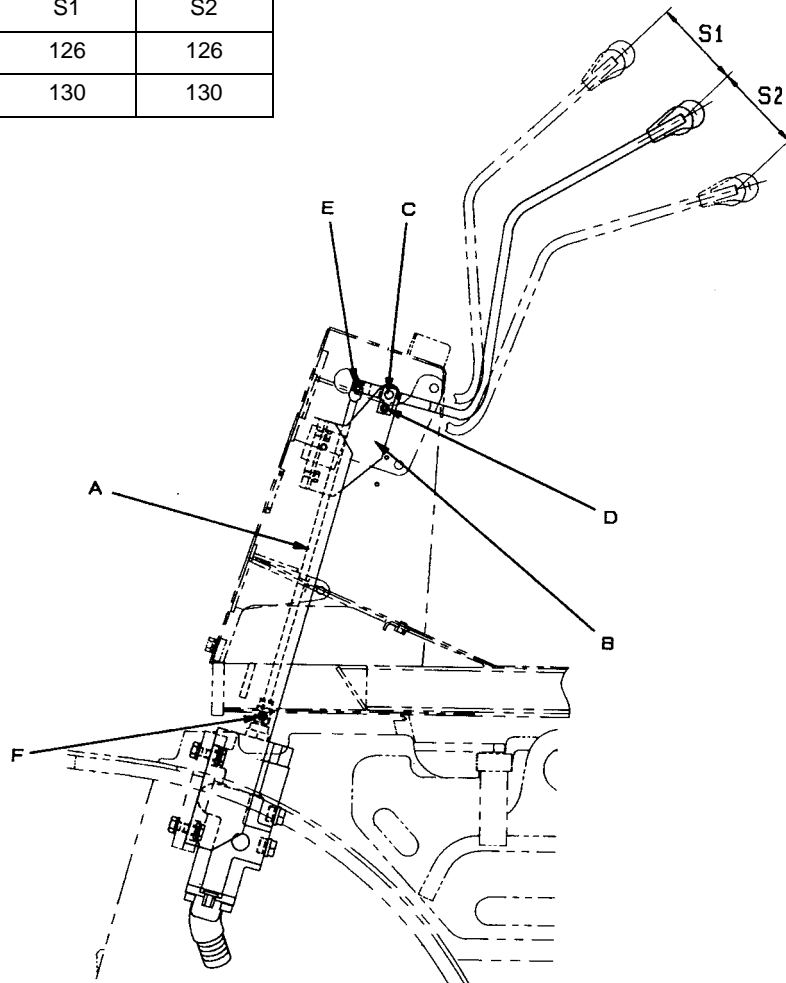

HAZ00539

# TORQFLOW TRANSMISSION

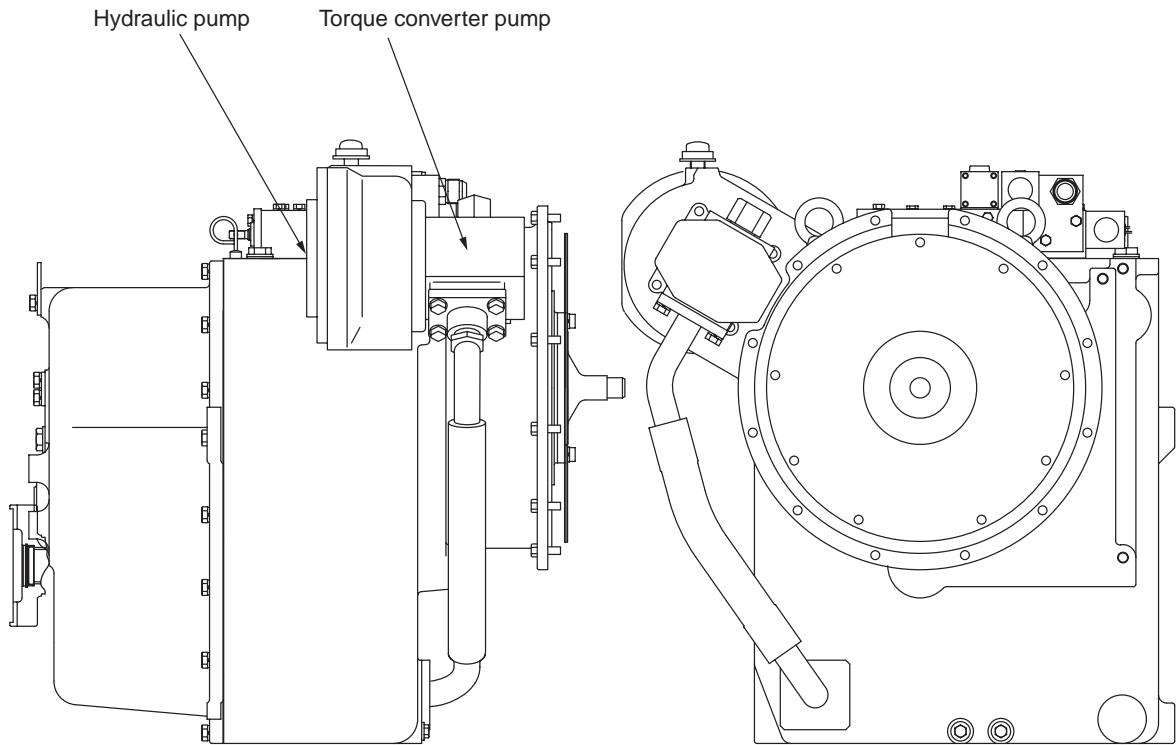

## INSPECTION

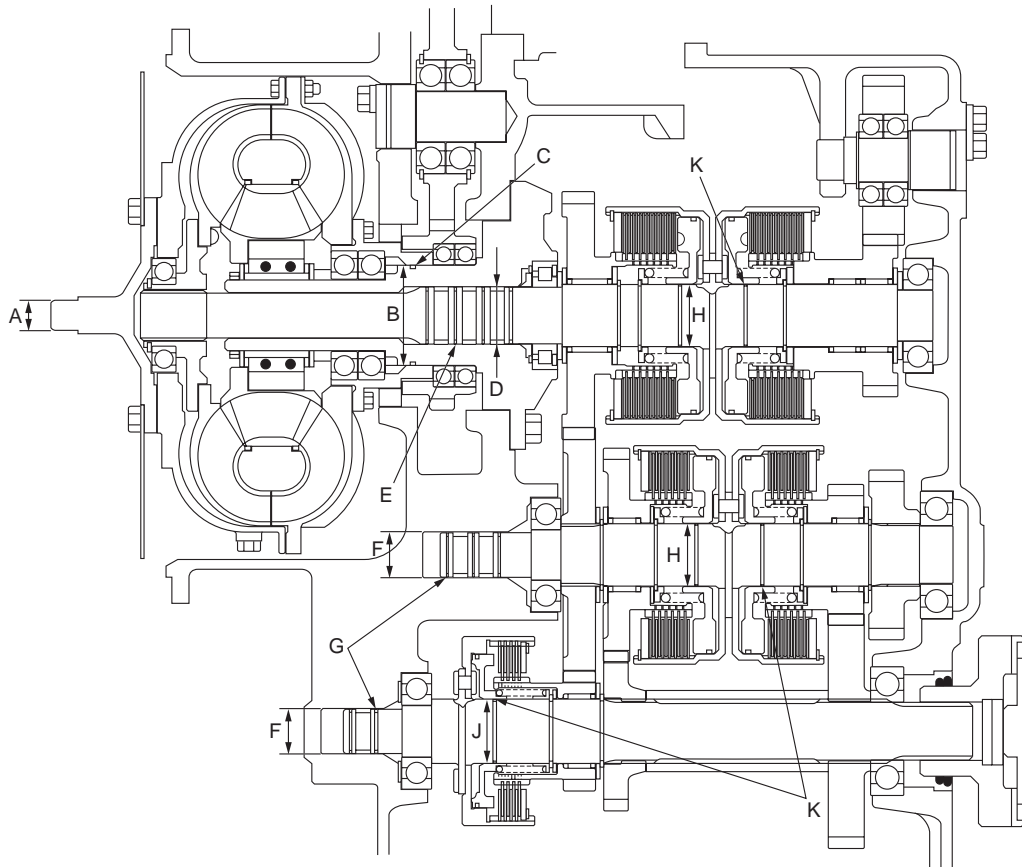

Symbol	Inspection item	Judgement standard		Remedy	
		Standard size (mm)	Repair limit (mm)		
A	Wear of pilot boss (tip)	25	24.85	Replace	
B	Pump boss inner diameter (seal ring contact surface)	80	80.15		
C	Seal ring	Width	3.0		2.93
		Thickness	3.2		2.45
D	Stator shaft inner diameter (seal ring contact surface)	45	45.15		
E	Seal ring (4 points)	Width	2.5		1.93
		Thickness	2.0		1.52
F	Converter inner diameter (seal ring contact surface)	35	35.15		
G	Seal ring (5 points)	Width	2.5		1.93
		Thickness	2.0		1.52
H	Clutch piston inner diameter (piston ring contact surface) (4 points)	50	50.15		
J	Clutch piston inner diameter (piston ring contact surface)	50	50.15		
K	Piston ring (5 points)	Width	2.5		1.93
		Thickness	2.0		1.52

CLICK HERE TO **DOWNLOAD** THE COMPLETE MANUAL

- Thank you very much for reading the preview of the manual.
- You can download the complete manual from: [www.heydownloads.com](http://www.heydownloads.com) by clicking the link below



- Please note: If there is no response to CLICKING the link, please download this PDF first and then click on it.

CLICK HERE TO **DOWNLOAD** THE COMPLETE MANUAL

## 2. Clutch shaft sub assembly

- 1) Assemble the 1st/2nd and 3rd clutch shaft sub assemblies.
  - ✕ Assemble the 1st/2nd and 3rd clutch shaft sub assemblies together as a set.
    - Set the special tools to the shaft sub assemblies.
    - Fit the lifting equipment to the eyebolts.
    - Set so that the 1st/2nd and 3rd clutch shaft sub assemblies mesh at the respective gear position.
    - Raise slowly and set in position above the torque converter case.
    - Check that the position of each gear is aligned as shown in the diagram on the right (the vertical position should be meshed within the range of the gear width).
    - Check that the busing has entered the 3rd shaft hole at the torque converter case end.
    - Lower the assembly slowly and check that the tip of each shaft is facing the shaft hole in the torque converter case.
    - In addition, be careful of the position of the seal ring.
    - There is a washer on the 3rd shaft, so check that it is not at an angle.
    - Lower the assembly to set the 1st/2nd and 3rd clutch shaft sub assemblies completely in position.
  - ★ For safety reasons, always use a hoist.
  - ★ If it is difficult to insert the shafts in the torque converter case, raise the shaft slightly then lower again. In this case, the shafts should enter easily. Never try to push in by force.

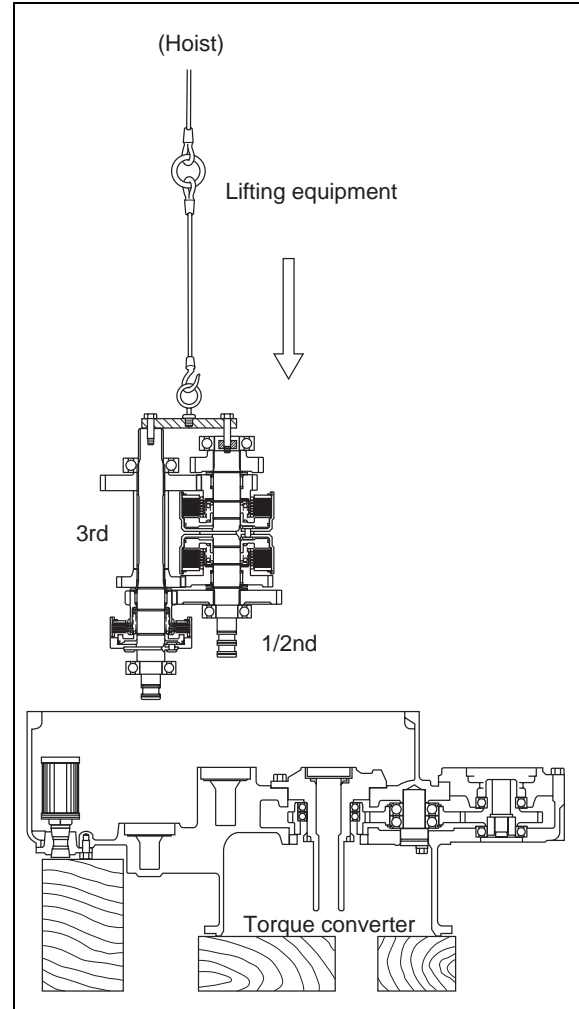

**Checking tooth contact**

- i) Coat the tooth face of the bevel pinion lightly with red lead (minimum).
  - ii) Rotate the bevel gear forward and backward.
  - iii) Inspect the pattern left on the teeth.
  - iv) If the result of the inspection shows that the correct tooth contact is not being obtained, adjust again as follows.
    - Adjust shims at pinion shaft
    - Adjust backlash of bevel gear
    - Adjust preload of bevel gear side bearing
- Tooth contact should be checked with no load on the bevel pinion. The tooth contact pattern should cover about 40–75 % of the length of the tooth, with weak contact at both ends. It should be in the center of the tooth height.
    - ★ The tooth contact should be correct on both the FORWARD and REVERSE sides of the teeth. However, if it is impossible to adjust both sides correctly, the FORWARD side must be correct.

Swing of bevel gear	within 0.1 mm (0.004 in)
------------------------	--------------------------

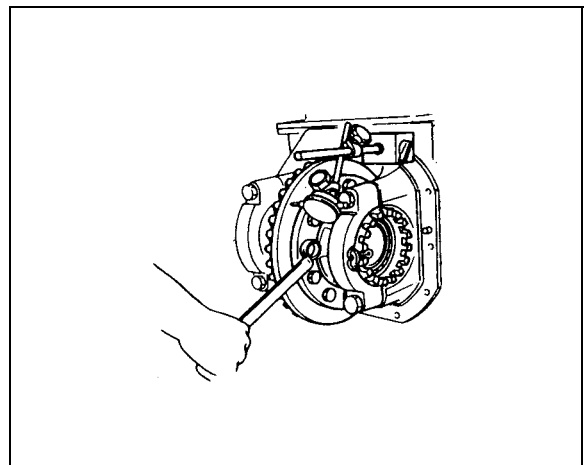
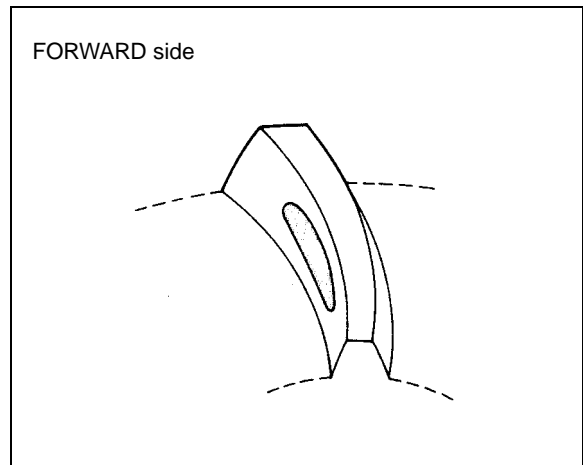
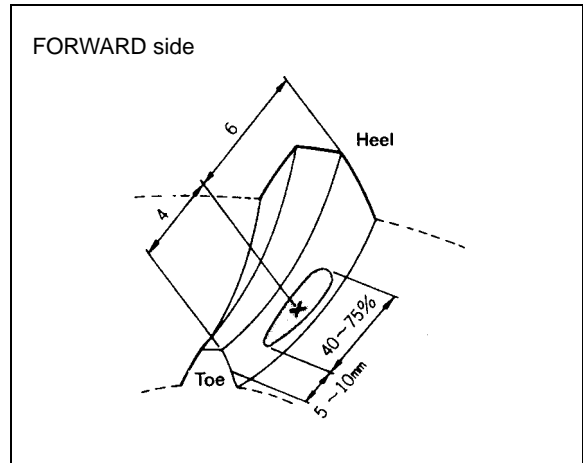

- Remove O-ring ⑦ from valve sub-assembly ③ with fingers.
- Remove O-ring ⑧ from guide ② with fingers.
- Remove O-ring ⑨, back-up ring ⑩ and O-ring ⑪ from reaction piston with fingers or a hair-pin.

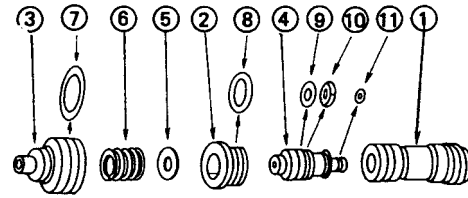

**ASSEMBLY**

★ Clean all parts and dry thoroughly.

1. Coat the O-rings and cup with silicon grease supplied with O-ring kit.
2. Cup ②
  - Follow the method shown in Fig. A when installing.
  - ★ Wind the outside of the spring with vinyl tape and make a guide to install the cup.
  - ★ The cup must be faced as shown in Fig. A.

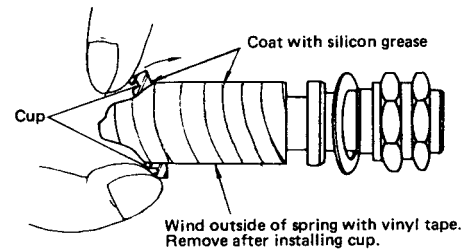
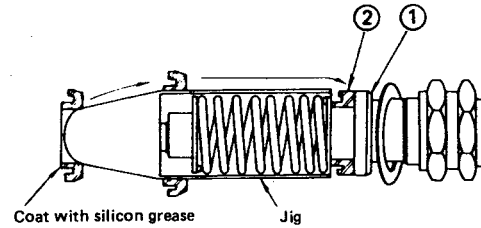

- Install input piston sub-assembly ② and washer ③ in body ① and fix with snap ring.
- Assemble sub-assembly with spool ⑤, reaction piston ⑥ and guide ⑦.

**FD100/115 only**

- Install spring ⑧ in hole in spool ⑤.
- Install sub-assembly with spool ⑤.
- ★ Coat spool ⑤ with engine oil.

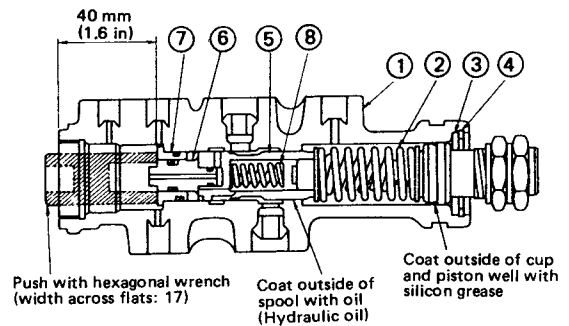

	SAE10W
mm (in)	
Standard depth of guide	40 (1.6)

## 2. Assembly of Gerotor assembly

- 1) Prepare bolt (19).
- 2) Fit O-ring (15) in the groove of the end cover, then pass 2 or 3 bolts through it.
- 3) Fit O-ring (15) in the groove of the outside part (stator) of the Girotor, then set on the end cover with the O-ring end at the top. Fit an O-ring to the cap and assemble it on the inside part (rotor).

Assemble this inside part (rotor) inside the stator on the position shown right with the spline chamfer at the top.

- ★ Coat with clean hydraulic oil when assembling.  
Set the spacer (17) inside the spline of rotor.

- 4) Fit the spline end of drive shaft (13) in the rotor spline part of the Girotor.

- ★ Align the direction of the pin groove of the drive shaft and the direction of the bottom of the teeth of the rotor teeth face as shown. If there is any mistake in the assembly position, the steering wheel will shake violently and repeatedly to the left and right, and operation will become impossible, so pay particular attention to this point.

- 5) Place plate (14) on top of the Girotor to complete the assembly of the Girotor assembly.

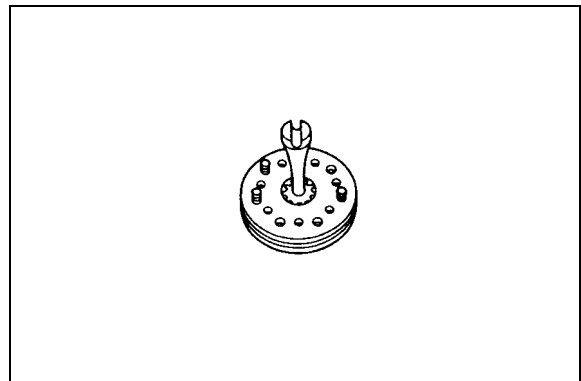
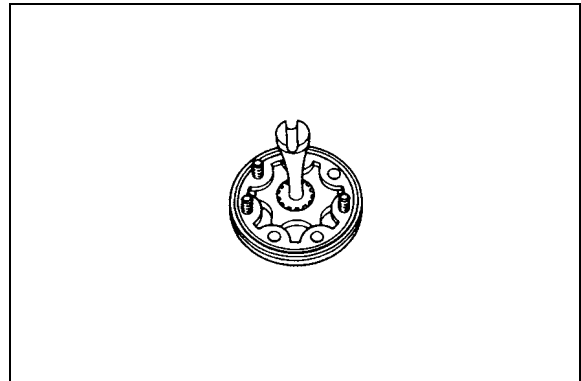
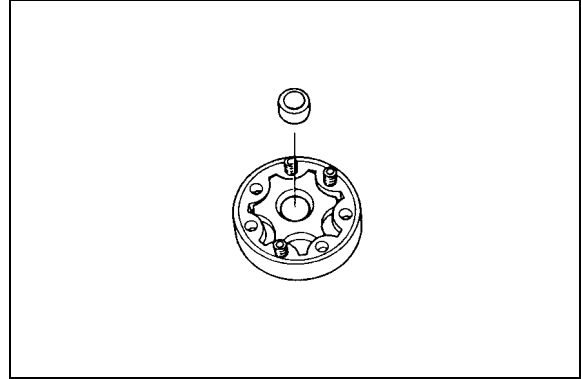

- 8) Use a press-fitting tool to press fit the dust seal, then install the snap ring (tilt cylinder only).

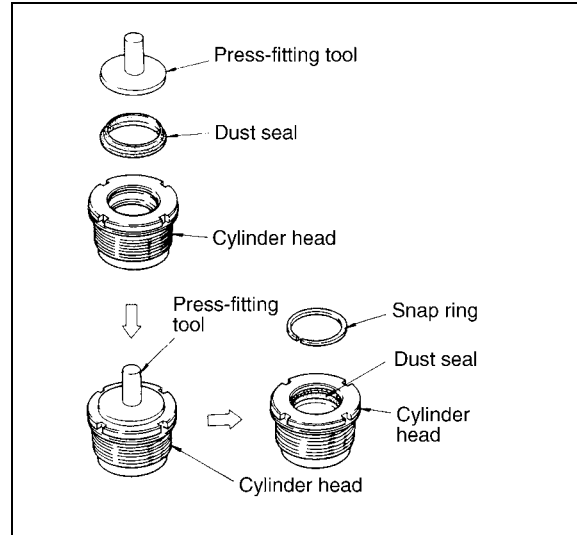

## 2. Assembly of piston assembly

- 1) To prevent damage to the seal, use an oilstone to remove any burrs or flashes at the places marked O in the diagram on the right.

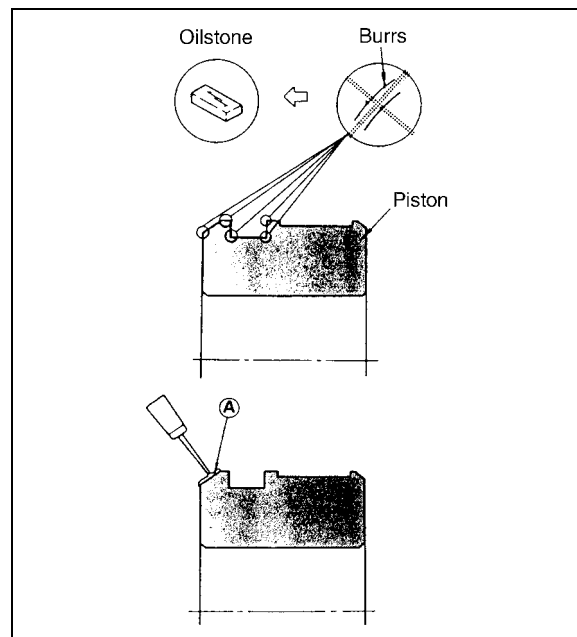

- 2) Coat top portion (A) of the piston taper surface with grease or hydraulic oil.

- 3) Insert one end of the piston ring into the groove first, then push the other side along the taper surface by hand to expand and install it.

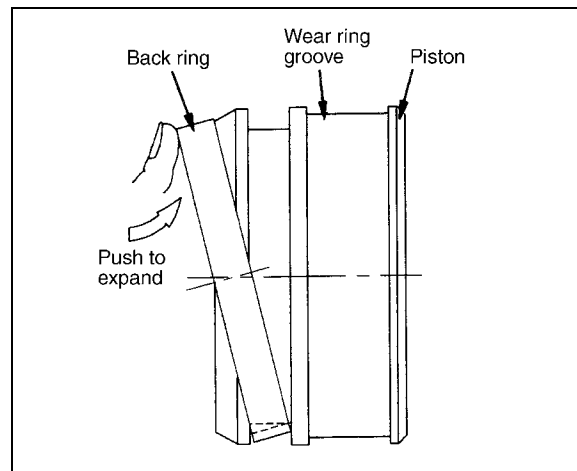

**FORK CARRIAGE**

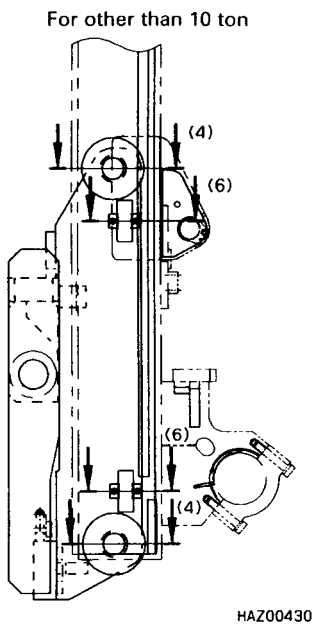
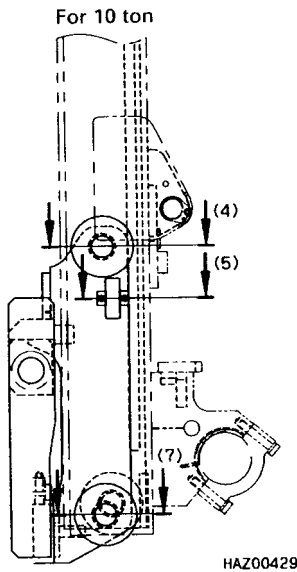

**Shim adjustment**

**(4) 10-ton truck upper roller**

No shim adjustment is needed for the upper roller or lower roller trucks other than the 10-ton truck (Held with snap ring)

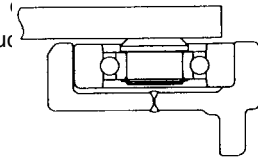

HAZ00431

**(5) Side roller (10-ton only)**

d	0.5–1.0 mm
---	------------

Adjust with shims so that clearance d between the roller and rail is 0.5–1.0 mm at the highest point of the inner rail.

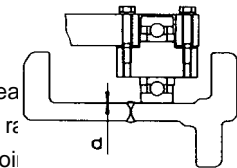

HAZ00432

**(6) Side roller (other than 10-ton)**

e	0.5–1.0 mm
---	------------

Adjust with shims so that clearance e between the roller and rail is 0.5–1.0 mm at the highest point of the inner rail.

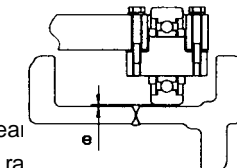

HAZ00433

**(7) Lower roller (10 ton only)**

f	0.5–1.0 mm
---	------------

Insert the same thickness shim on the left and right to adjust that clearance f between the rail and roller is 0.5–1.0 mm at maximum lifting height.

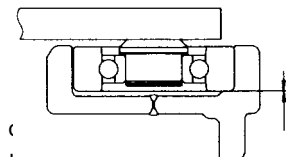

HAZ00434

## LOCATION OF SWITCHES AND SENSORS

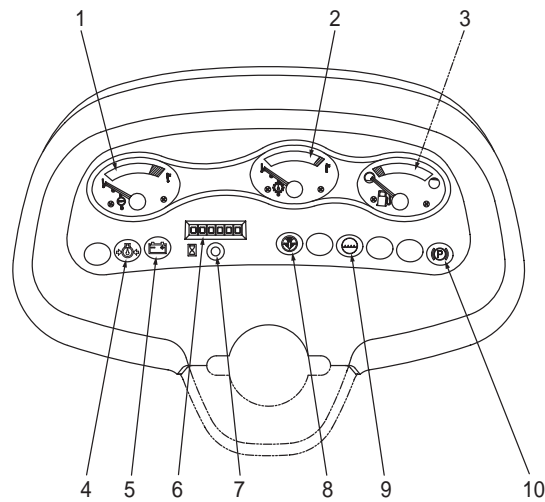
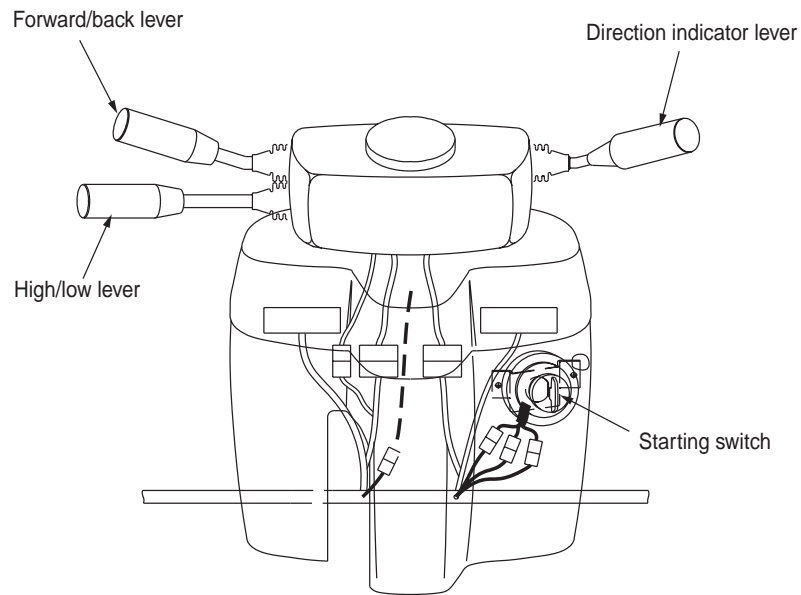

- 1.Engine coolant thermometer
- 2.Torque converter oil thermometer
- 3.Fuel gauge
- 4.Engine oil pressure warning lamp
- 5.Charge warning lamp
- 6.Hour meter
- 7.Operation indicator
- 8.Air cleaner clogging warning lamp
- 9.Radiator coolant level warning lamp
- 10.Parking brake warning lamp

# STEERING

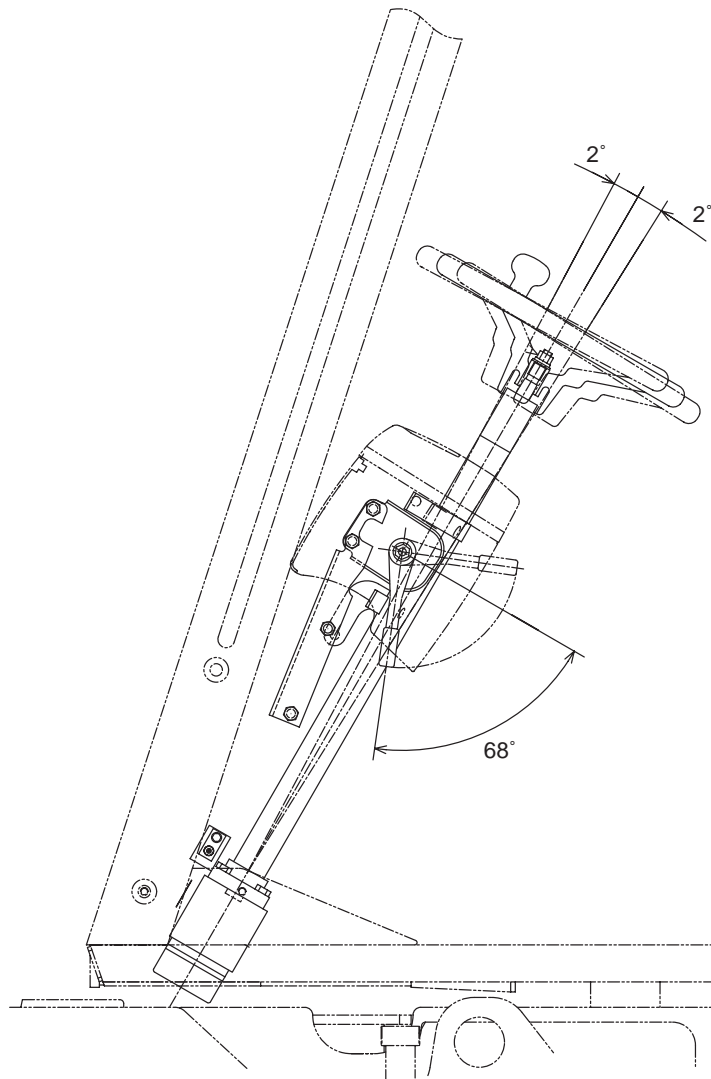

Symbol	Inspection item	Judgement standard		Remedy
		Standard size (mm)	Repair limit (mm)	
	Steering wheel play (when idling)	30-60	30-60	
	Steering wheel tilt angle	2° + 2°	2° + 2°	
	Steering wheel lock lever, lock angle	68°	68°	
	Operating effort of steering wheel (at knob)	98 N {10 kgf}		
※	Set pressure of hydraulic relief valve (see page 50-25)	10.2-15.2 MPa {127.5-132.5 kg/cm <sup>2</sup> }		

# LIFT CYLINDER

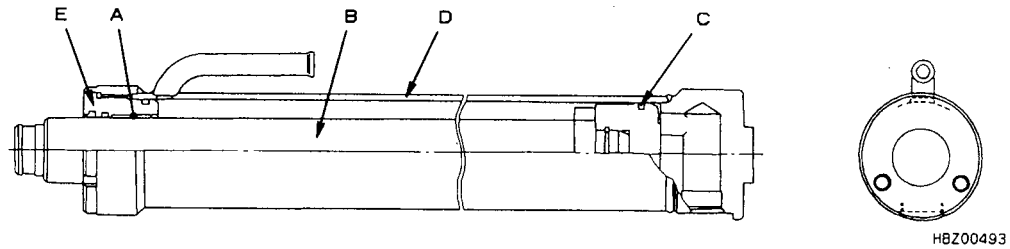

(Lifting height: 3m)

Item	Unit	FD100	FD115	FD135/150E	160E
Cylinder (inside diameter x outside diameter)	mm	95 x 110	100 x 113	110 x 124	120 x 136
Stroke	mm	1510			
Outside diameter of rod	mm	65	70	75	
Weight	kg	85	90	105	110

## INSPECTION

Symbol	Inspection item		Judgement standard		Remedy
			Standard size (mm)	Repair limit (mm)	
A	Clearance between piston rod and bushing	FD100	0.097–0.366	0.666	Replace bushing
		FD115/135/150E/160E	0.107–0.395	0.695	
B	Piston rod		Scratches that catch finger nail, dents, hollows		Replace
C	Piston ring		Scratches that catch finger nail		
D	Cylinder		Scratches that catch finger nail, hollows		
	(Tightening torque)				
E	Cylinder head	FD100	662–808 Nm {67.5–82.5 kgm}		
		FD115	706–862 Nm {72–88 kgm}		
		FD135–150E	838–1024 Nm {85.5–104.5 kgm}		
		FD160E	882–1078 Nm {90–110 kgm}		

## 1. Hydraulic Circuit (Outline)

- 1) When the engine is started, the charging pump is driven and the oil inside the transmission case passes through the strainer and is sucked in or pumped out.
- 2) The oil leaving the gear pump presses through the line filter, is regulated by the main regulator valve, and fills the accumulator.
- 3) When the circuit is switched to FORWARD or REVERSE (and 1st to 3rd for each direction) by the solenoid valve, the oil inside the accumulator is supplied to the circuit leading to the hydraulic clutches.
- 4) After the clutch is actuated, the oil on the hydraulic circuit side continues to fill the accumulator and flows to the clutch side, so the pressure inside the clutch gradually rises and the transmission of power is carried out smoothly.
- 5) The oil cooled in the oil cooler is sent inside the transmission and carries out lubrication and cooling of all parts. It then returns to the transmission case. (For details, see the hydraulic circuit diagram on the following pages.)

## 2. Operation of clutch

- 1) If the F/R lever is placed at F1 or R1, the solenoid valve turns F or R and 1st ON, and oil pressure actuates the F or R clutch and the 1st clutch.
- 2) If the F/R lever is places at F2 or R2, the solenoid valve turns F2 or R ON, and oil pressure actuates the F or R clutch. With the 2nd clutch, oil pressure passes through the 1st and 3rd solenoid valves (these are OFF) and carries out actuation, so the 2nd clutch actuates the F or R clutch.
- 3) If the F/R lever is placed at F3 or R3, the solenoid valve turns F or R and 3rd ON, and oil pressure actuates the F or R clutch and the 3rd clutch. (For details, see the hydraulic circuit diagram on the following pages.)

**Steering when there is failure in hydraulic pump**

Even if the hydraulic pump breaks down and no hydraulic oil is supplied, the full hydraulic power steering is designed so that the steering equipment can be operated manually.

In other words, if the steering wheel is turned, the spool of the full hydraulic power steering is turned by the shaft, contacts the cross pin, and rotates the drive shaft.

When the drive shaft rotates, the rotor, which is meshed by a spline, also rotates, so the Gerotor acts as hand pump to send oil to the cylinder. When this happens, the check valve between the tank port and pump port opens, the oil from the tank side flows to the pump side, and this makes it possible to operate the steering manually in emergencies.

**Precautions**

1. The full hydraulic power steering (FHPS) is a type of hydraulic direction selector valve. There is no drag link or other mechanical connection with the rear axle, so if the steering is turned fully to the lock position, there is leakage of hydraulic oil inside the valve. This means that the position of the steering wheel knob when traveling in a straight line may become different.

It is possible to correct the position of the steering wheel knob as follows, but it is difficult to prevent this change in position from occurring.

**Method of correction**

- (1) Set the rear wheels facing straight.
  - (2) Turn the starting switch OFF.
  - (3) Check that the engine has stopped.
  - (4) Turn the steering wheel and set the steering wheel knob to the specified position.
2. Bleed all the air from the piping between the FHPS valve and power steering cylinder. (This causes abnormal noise and play in the steering wheel.)
  3. For safety reasons, always replace the hose between the FHPS valve and power steering cylinder once every two year.

## 70. TROUBLESHOOTING

Torque converter .....	70-2
Control valve .....	70-5
Check brake accumulator .....	70-7



CLICK HERE TO **DOWNLOAD** THE COMPLETE MANUAL

- Thank you very much for reading the preview of the manual.
- You can download the complete manual from: [www.heydownloads.com](http://www.heydownloads.com) by clicking the link below



- Please note: If there is no response to CLICKING the link, please download this PDF first and then click on it.

CLICK HERE TO **DOWNLOAD** THE COMPLETE MANUAL