

Shop Manual

BULLDOZER

D65EX -16

D65PX -16

D65WX -16

SERIAL NUMBERS

D65EX- 80001

D65PX- 80001

and up

D65WX-80001

ecot3

KOMATSU

CLICK HERE TO **DOWNLOAD** THE COMPLETE MANUAL

- Thank you very much for reading the preview of the manual.
- You can download the complete manual from: www.heydownloads.com by clicking the link below



- Please note: If there is no response to CLICKING the link, please download this PDF first and then click on it.

CLICK HERE TO **DOWNLOAD** THE COMPLETE MANUAL

Failure code [DDNLKB] Weq lock Sw: Short circuit	14
Failure code [DGS1KX] Hyd oil temp sensor: Abnormal	16
Failure code [DGT1KA] T/C oil temp sensor: Disconnection	18
Failure code [DGT1KX] T/C oil temp sensor: Short circuit	20
Failure code [DH21KA] Weq pressure sensor: Disconnection	22
Failure code [DH21KB] Weq pressure sensor: Short circuit	24
Failure code [DHT5KA] T/C pressure sensor: Disconnection	26
Failure code [DHT5KB] T/C pressure sensor: Short circuit	28
Failure code [DK10KA] Fuel control Dial: Disconnection	30
Failure code [DK10KB] Fuel control Dial: Short circuit	32
Failure code [DK30KA] ST lever 1: Disconnection	34
Failure code [DK30KB] ST lever 1: Short circuit	36
Failure code [DK30KX] ST lever: Out of normal range	38
Failure code [DK30KZ] ST lever: Disconnection or short circuit	38
Failure code [DK30L8] ST lever: Signal mismatch	39
Failure code [DK31KA] ST lever 2: Disconnection	40
Failure code [DK31KB] ST lever 2: Short circuit	42
Failure code [DK40KA] Brake potentiometer: Disconnection	44
Failure code [DK40KB] Brake potentiometer: Short circuit	46
Failure code [DK55KX] FR lever: Out of normal range	48
Failure code [DK55KZ] FR lever: Disconnection or short circuit	48
Failure code [DK55L8] FR lever: Signal mismatch	49
Failure code [DK56KA] FR lever 1: Disconnection	50
Failure code [DK56KB] FR lever 1: Short circuit	52
Failure code [DK57KA] FR lever 2: Disconnection	54
Failure code [DK57KB] FR lever 2: Short circuit	56
306 Troubleshooting by failure code (Display of code), Part 6	SEN05036-01
Failure code [DKH1KA] Pitch angle sensor: Disconnection	4
Failure code [DKH1KB] Pitch angle sensor: Short circuit	6
Failure code [DLT3KA] T/M out-speed sensor: Disconnection	8
Failure code [DLT3KB] T/M out-speed sensor: Abnormal	9
Failure code [DW5AKA] Pitch selector Sol.: Disconnection	10
Failure code [DW5AKB] Pitch selector Sol.: Short circuit	11
Failure code [DW5AKY] Pitch selector Sol.: Short circuit	12
Failure code [DW7BKA] Fan rev EPC: Disconnection	14
Failure code [DW7BKB] Fan rev EPC: Short circuit	15
Failure code [DWN1KA] Hss EPC1: Disconnection	16
Failure code [DWN1KB] Hss EPC1: Short circuit	17
Failure code [DWN1KY] Hss EPC1: Short circuit	18
Failure code [DWN2KA] Hss EPC2: Disconnection	19
Failure code [DWN2KB] Hss EPC2: Short circuit	20
Failure code [DWN2KY] Hss EPC2: Short circuit	21
Failure code [DWN5KA] Fan pump solenoid: Disconnection	22
Failure code [DWN5KB] Fan pump solenoid: Short circuit	23
Failure code [DWN5KY] Fan control solenoid: Short circuit	24
Failure code [DXA0KA] TVC Sol.: Disconnection	26
Failure code [DXA0KB] TVC Sol.: Short circuit	27
Failure code [DXA0KY] TVC Sol.: Short circuit	28
Failure code [DXH1KA] Lock-up ECMV: Disconnection	29
Failure code [DXH1KB] Lock-up ECMV: Short circuit	30
Failure code [DXH1KY] Lock-up ECMV: Short circuit	32
Failure code [DXH4KA] 1st clutch ECMV: Disconnection	34
Failure code [DXH4KB] 1st clutch ECMV: Short circuit	35
Failure code [DXH4KY] 1st clutch ECMV: Short circuit	36
Failure code [DXH5KA] 2nd clutch ECMV: Disconnection	37
Failure code [DXH5KB] 2nd clutch ECMV: Short circuit	38
Failure code [DXH5KY] 2nd clutch ECMV: Short circuit	39
Failure code [DXH6KA] 3rd clutch ECMV: Disconnection	40

1. Brake valve
2. HSS motor
3. Output shaft
4. Brake spring (large)
5. Brake spring (small)
6. Spacer
7. Hub
8. Cage
9. Piston
10. Cover
11. Plate (one side: 4 pcs.)
12. Disc (one side: 5 pcs.)
13. Brake drum
14. Brake hub
15. Gear A (number of teeth: 38/55)
16. Cage
17. Gear B (number of teeth: 32)
18. Bevel gear shaft
19. Bevel gear (number of teeth: 34)
20. Bearing
21. Shaft
22. Gear C (number of teeth: 32)
23. Planetary pinion (number of teeth: 26)
24. Ring gear (number of teeth: 91)
25. Pinion shaft
26. Hub
27. Carrier
28. Gear D shaft
29. Gear D (number of teeth: 48)
30. HSS motor drive gear (number of teeth: 25)
31. Bevel pinion (number of teeth: 25)
32. Cage

Unit: mm

No.	Check item	Criteria				Remedy
		Standard size	Tolerance		Standard clearance	
Shaft	Hole					
7	Clearance between main brake valve and body	19	-0.020 -0.030	+0.013 0	0.020 – 0.043	0.07
8	Clearance between main brake valve and piston	9	-0.030 -0.040	+0.015 0	0.030 – 0.055	0.08
9	Clearance between parking brake valve and body	19	-0.034 -0.043	+0.013 0	0.034 – 0.056	0.08
10	Main brake modulating spring	Standard size			Repair limit	
		Free length	Installed length	Installed load	Free length	Installed load
		48	36	75.3 N {7.68 kg}	46.6	71.6 N {7.3 kg}
11	Main brake valve return spring	52	38	157.9 N {16.11 kg}	50.4	150 N {15.3 kg}
12	Parking brake valve return spring	36.5	28.5	16.7 N {1.7 kg}	35.4	15.7 N {1.6 kg}

The power from HSS



Pinion (1)



Gear (2)



Sun gear (3)



Planetary pinion (4)



Pinion shaft (5)



Carrier (6)



Sprocket hub (7)



Sprocket teeth (8)

Processing on machine monitor (common to all specifications)

Display of machine monitor

Contents and conditions of processing	Method	Flow of signals
1. Display of direction of travel and gear speed • Based on the information from the power train controller, F1, R3, etc. are transmitted to the machine monitor in CAN signal.	CAN signal	<p>Sensors and solenoids ↓ Controller ↓ Machine monitor</p>
2. Display of gauge such as fuel level, engine coolant temperature, etc. • The controller converts the sensor signals into gauge numbers and sends them to the machine monitor by CAN signal.	CAN signal	
3. Display of failure • If the machine failure occurs, the controller transmits the corresponding failure code to the machine monitor in CAN signal. • Depending on the content of failure, the controller transmits information whether the alarm buzzer should be sounded. • The following information is displayed on the machine monitor: 1) In the normal state • Action code (3-digit code) • Failure code (6-digit code) 2) In the abnormality record display mode • Failure code (6-digit code) • Service meter hours when the failure occurred for the first time • Service meter hours when it occurred the last time • Frequency of occurrence	CAN signal	

Display of monitoring

Contents and conditions of processing	Method	Flow of signals
1. Display of sensors, solenoids and communicating state of CAN signal • The monitoring system transmits the item No. and equipment status to the machine monitor in CAN signal. • The machine monitor displays the items and values.	CAN signal	<p>Sensors ↓ Controller ↓ Machine monitor</p>
2. Items are selected by using the function switch.	CAN signal	

Other items

Contents and conditions of processing	Method	Flow of signals
1. Monitoring 2. Abnormality record 3. Maintenance record 4. Maintenance mode change 5. Phone number entry 6. Default 7. Adjustment 8. PM clinic 9. Cylinder cut-out 10. No injection 11. Fuel consumption 12. KOMTRAX settings 13. Service message	—	—

★ For details of the operating method, see "Special functions of monitor panel (EMMS)" in "Testing and adjusting".

Electronic steering control system

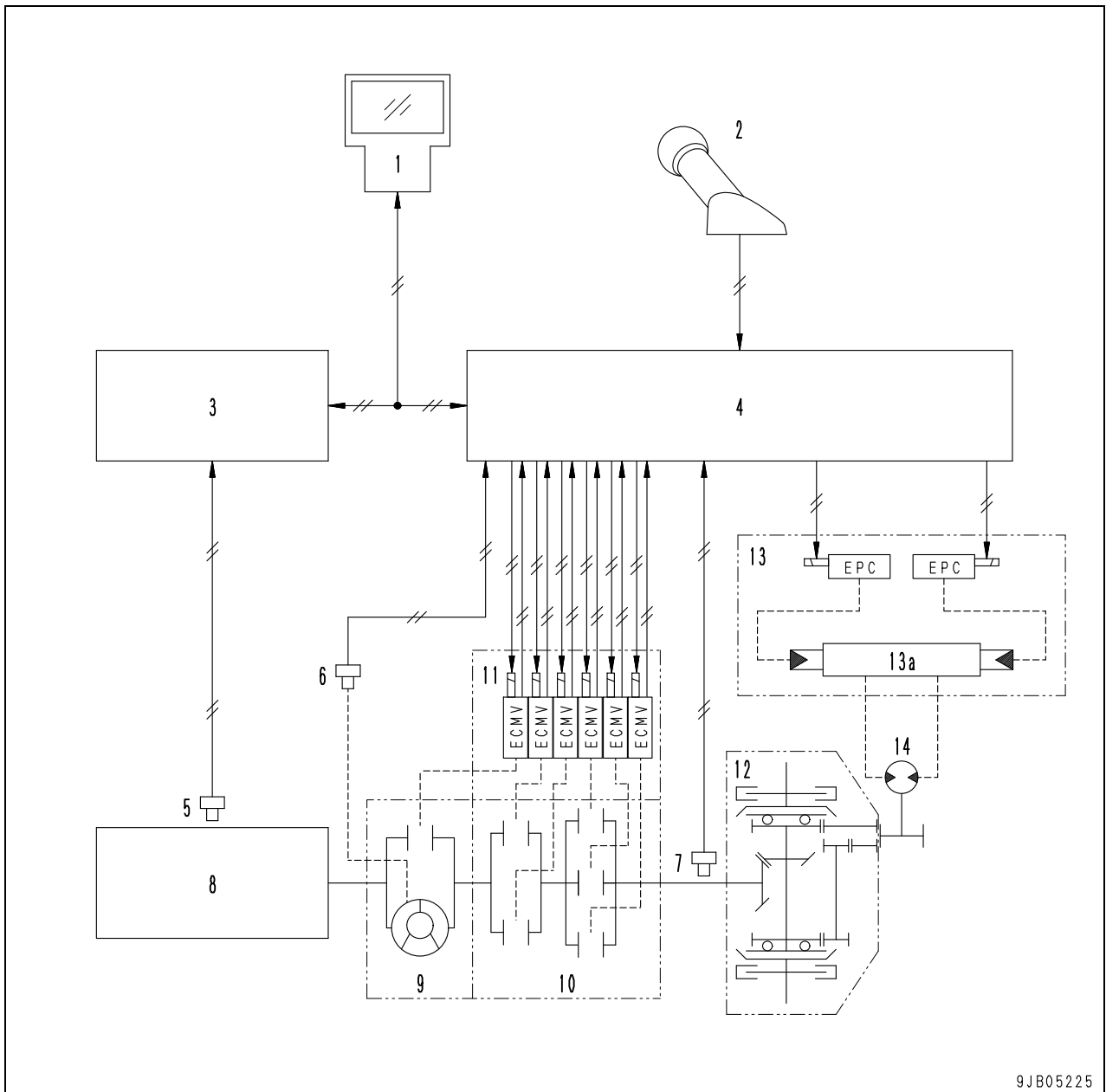

9JB05225

- | | |
|---|--------------------------------|
| 1. Machine monitor | 8. Engine |
| 2. Steering, directional, gear shift lever (PCCS lever) | 9. Torque converter |
| 3. Engine controller | 10. Transmission |
| 4. Power train controller | 11. Transmission control valve |
| 5. Engine speed sensor | 12. HSS unit |
| 6. Torque converter oil pressure sensor | 13. Control valve |
| 7. Transmission output speed sensor | 13a. Steering control valve |
| | 14. HSS motor |

Crankshaft angle sensor (Ne sensor)

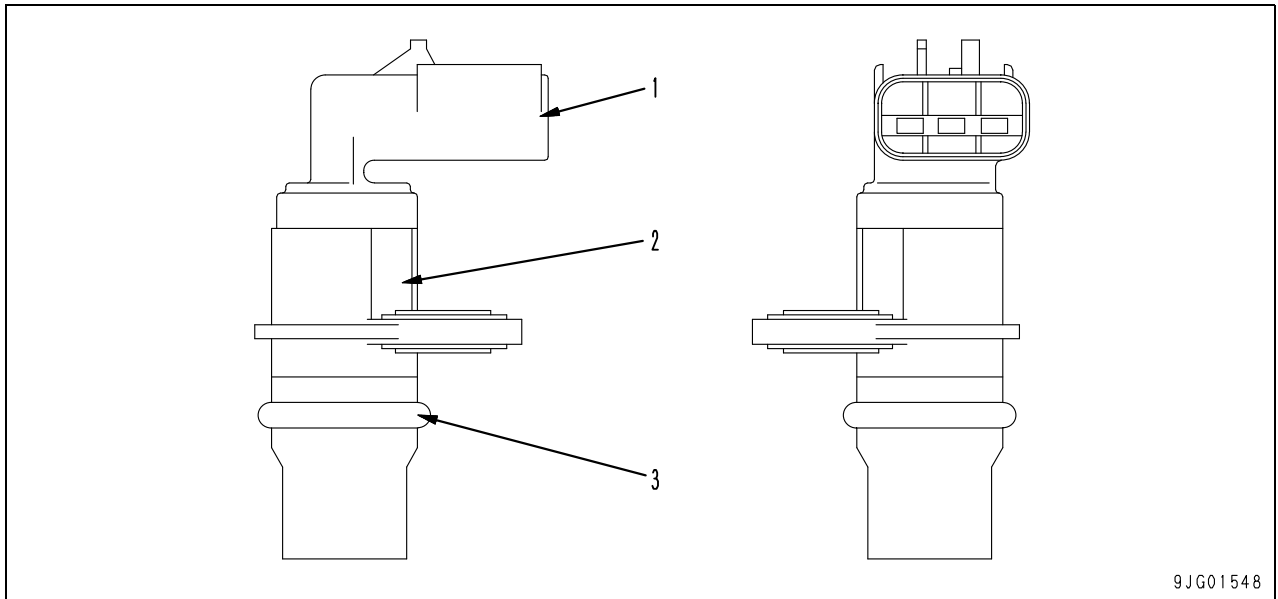

- 1. Connector
- 2. Sensor
- 3. O-ring

Boost pressure, temperature sensor

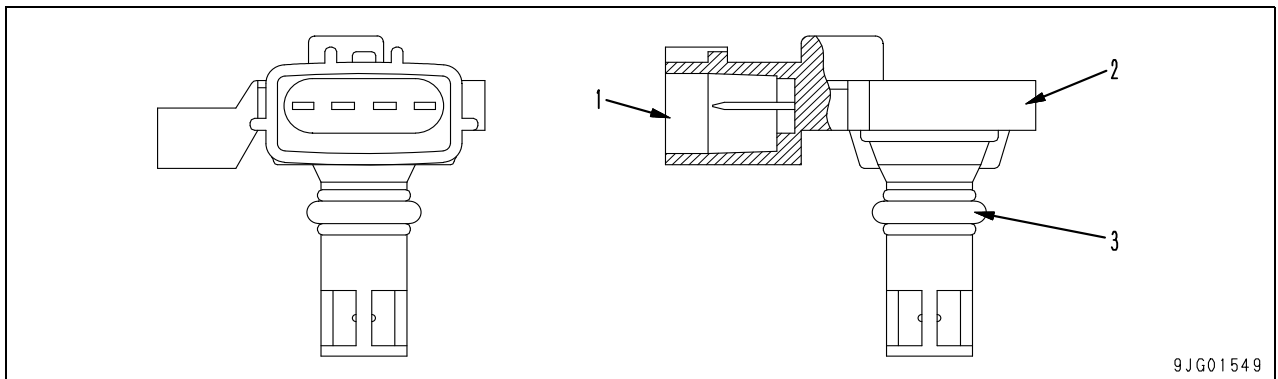

- 1. Connector
- 2. Sensor
- 3. O-ring

BULLDOZER

D65EX-16

D65PX-16

D65WX-16

Machine model	Serial number
D65EX-16	80001 and up
D65PX-16	80001 and up
D65WX-16	80001 and up

50 Disassembly and assembly

100 General information on disassembly and assembly

How to read this manual	2
Coating materials list.....	4
Special tool list	7
Sketches of special tools	17

Item	Symbol	Part No.	Part name	Necessity	Qty	New/remodel	Sketch	Nature of work, remarks	
Disassembly and assembly of final drive (Planetary gear installed inside of sprocket type)	J	12	790-431-1031	Block	■	1			Press fitting of sprocket hub bearing
			791-520-4140	Screw	■	1			
			791-112-1180	Nut	■	2			
			01643-22460	Washer	■	2			
			791T-527-1130	Plate	■	1	N	○	
			791T-527-1120	Push tool	■	1	N	○	
			790-101-2102	Puller	■	1			
			790-101-1102	Hydraulic pump	■	1			
	13	791-580-8110	Installer	■	1			Installation of floating seal	
	14	790-101-5201	Push tool kit	■	1				Installation of oil seal, Press fitting of bearing
		790-101-5321	• Plate	■	1				
		790-101-5311	• Plate	■	1				
		790-101-5221	• Grip	■	1				
		01010-51225	• Bolt	■	1				
	15	790-101-5401	Push tool kit	■	1				
		790-101-5441	• Plate	■	1				
		790-101-5431	• Plate	■	1				
		790-101-5421	• Grip	■	1				
	16	01010-51240	• Bolt	■	1				
		790-101-5630	Plate	■	1	N			
790-101-5421		Grip	■	1					
		01010-51240	Bolt	■	1				
Disassembly and assembly of idler assembly	L	1	791-515-1520	Installer	■	1		Installation of floating seal	
Disassembly and assembly of track roller assembly		2	791-530-1520	Installer	■	1			
Disassembly and assembly of carrier roller assembly		3	796-230-1110	Installer	■	1			
Disassembly and assembly of idler assembly and track roller assembly		4	791-601-1000	Oil pump	■	1		Supply of oil	
Disassembly and assembly of recoil spring assembly	M	791-685-8005	Compressor of type B	■	1			Disassembly, assembly of recoil spring assembly	
		791-635-3160	Extension	■	1				
		790-201-2780	Spacer	■	1				
		790-201-2790	Spacer	■	1				
		790-101-1102	Pump	■	1				
		790-101-1600	Cylinder	■	1				
Removal and installation of equalizer bar assembly	N	791-450-1100	Remover assembly	■	1			Pulling out of center pin	
		790-101-2102	Puller	■	1				
		790-101-1102	Pump	■	1				

Note: Komatsu cannot accept any responsibility for special tools manufactured according to these sketches.

E9 Push tool

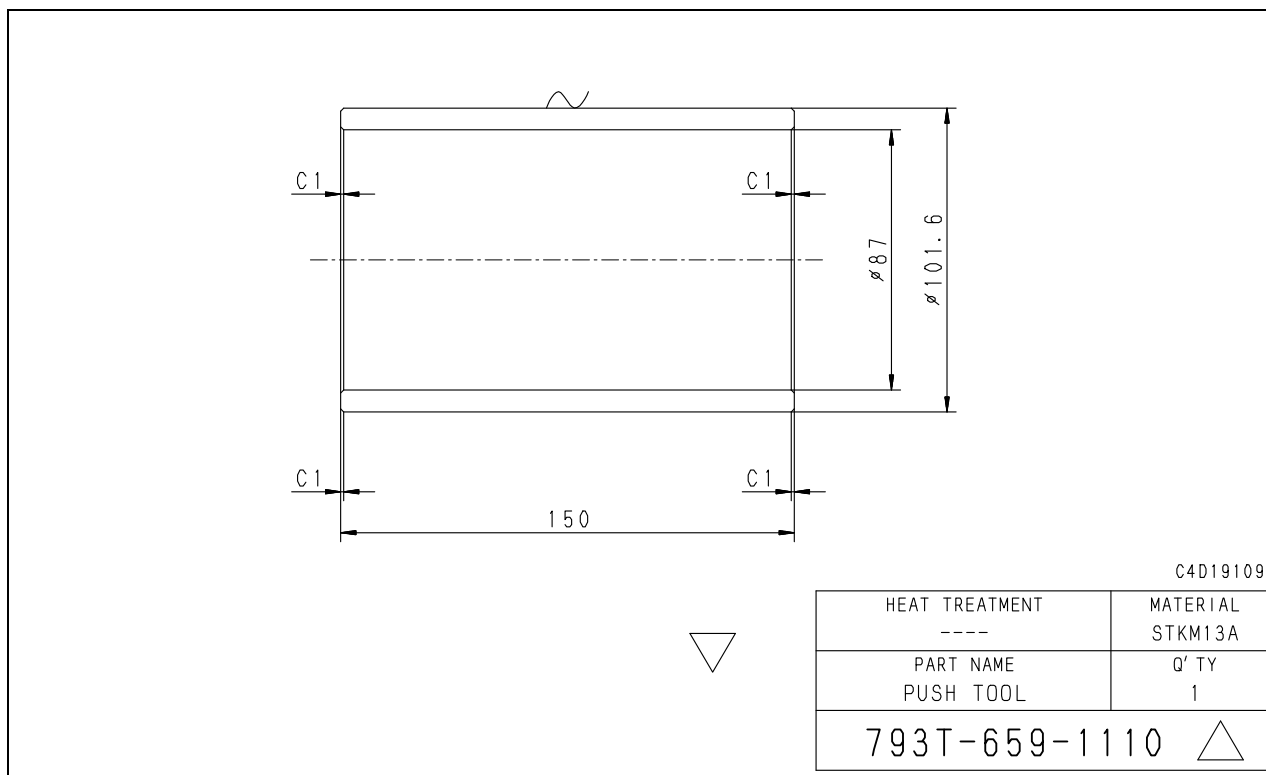

E10 Push tool

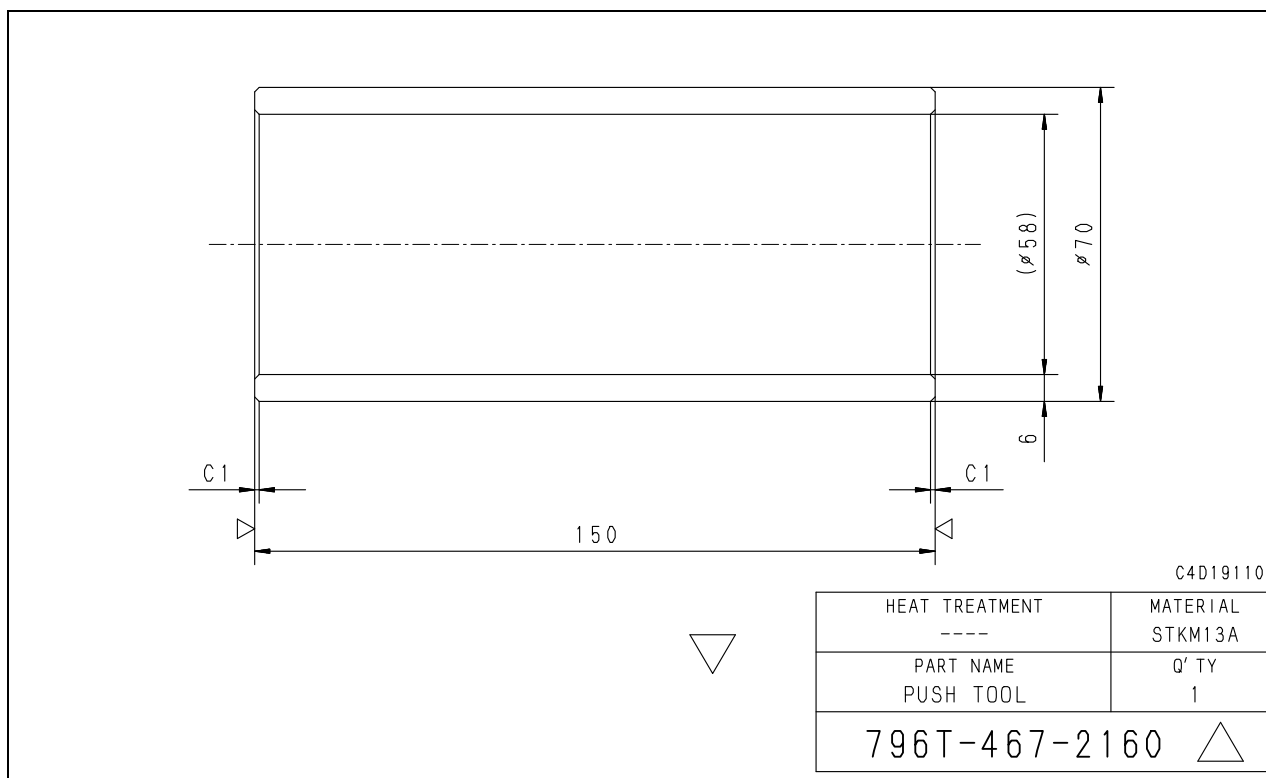

Note: Komatsu cannot accept any responsibility for special tools manufactured according to these sketches.

R20 Push tool

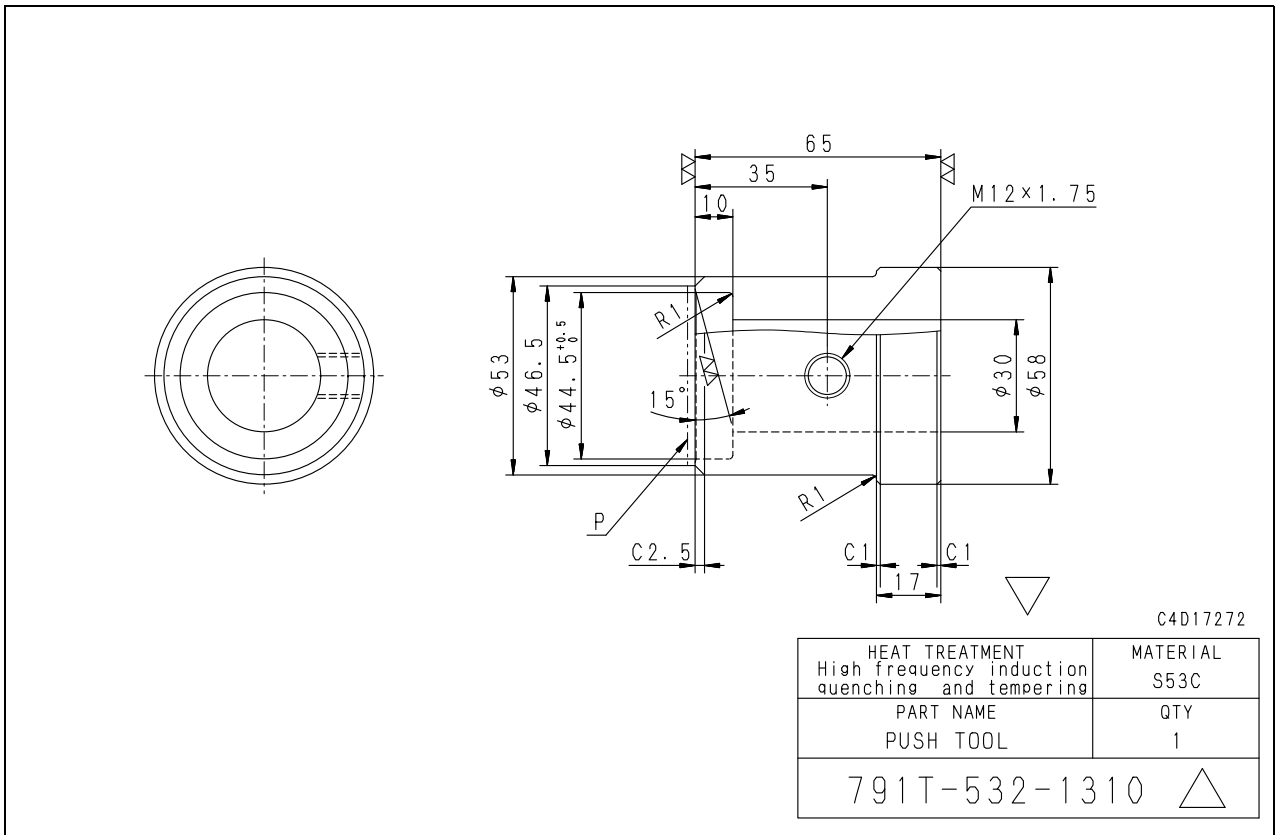

R21 Push tool

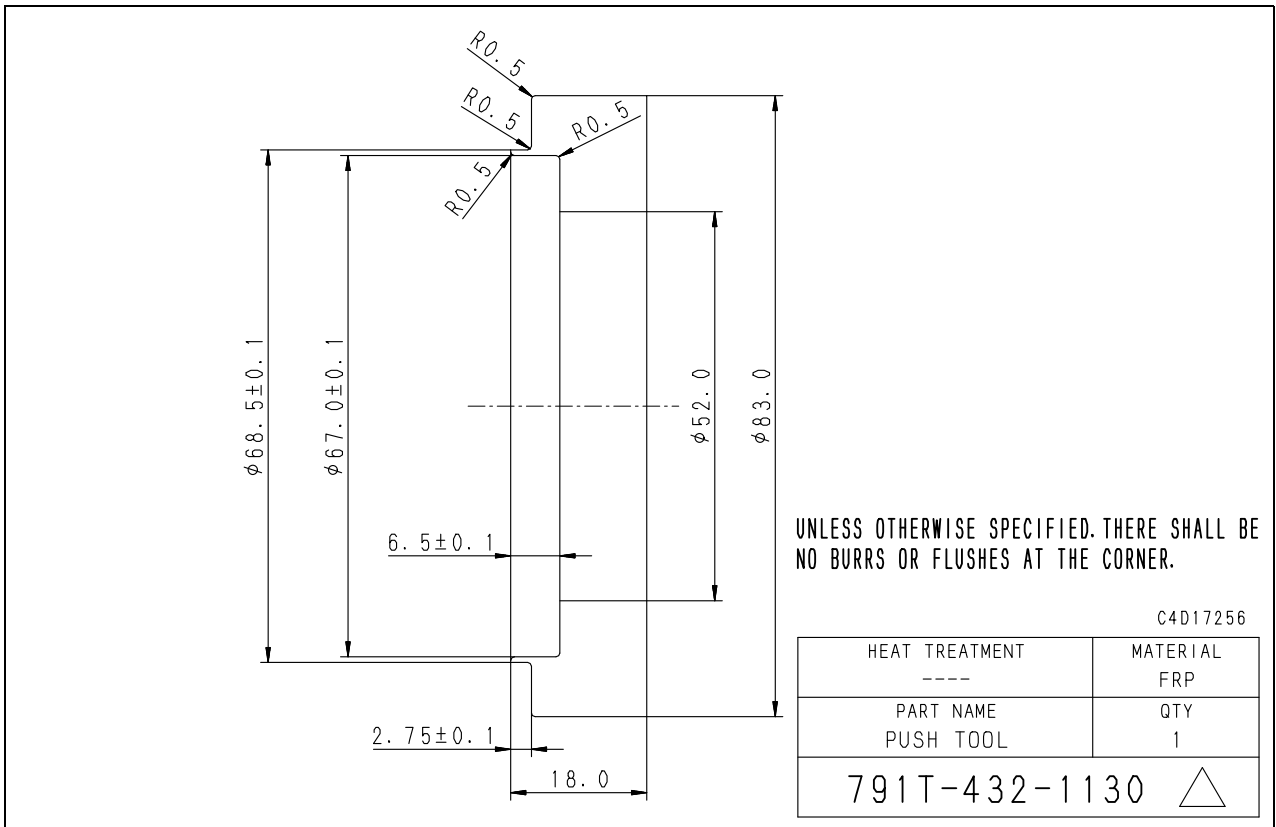

CLICK HERE TO **DOWNLOAD** THE COMPLETE MANUAL

- Thank you very much for reading the preview of the manual.
- You can download the complete manual from: www.heydownloads.com by clicking the link below



- Please note: If there is no response to CLICKING the link, please download this PDF first and then click on it.

CLICK HERE TO **DOWNLOAD** THE COMPLETE MANUAL

26. Using forcing screw [3], remove retainer assembly (23).

27. Remove oil seal (24) from retainer assembly (23). [*7]

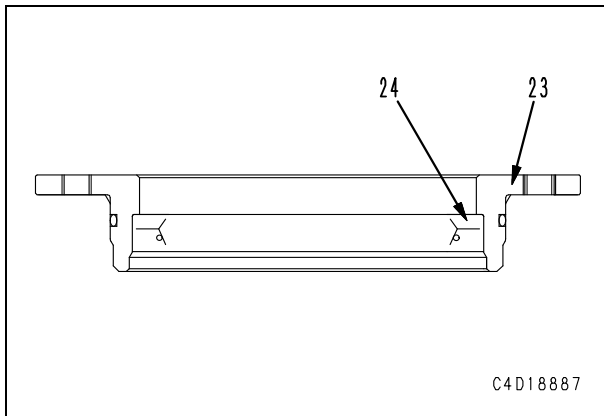
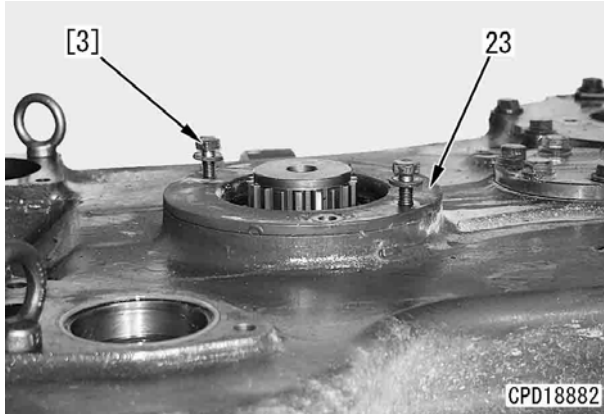

28. Remove all mounting bolts (26).

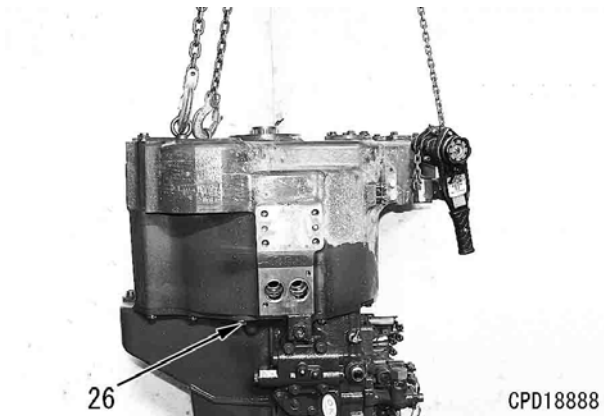

29. Lift off PTO assembly (27). [*8]

★ The torque converter assembly is left on the transmission side.

☞ PTO assembly (27): **210 kg**

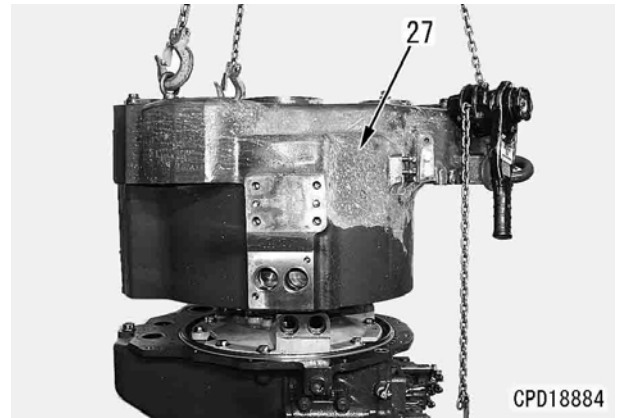

30. Remove 9 mounting bolts (28) and lift off torque converter assembly (29). [*9]

☞ Torque converter assembly (29): **140 kg**

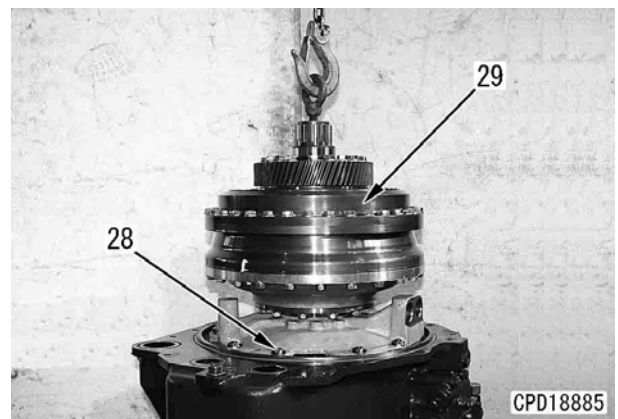

31. Sling transmission assembly (30) and remove it.

☞ Transmission assembly (30): **380 kg**

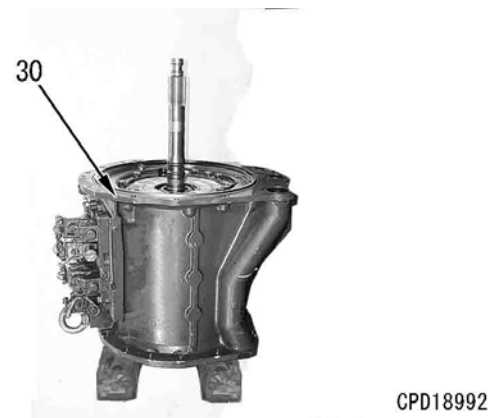

4. Stator assembly

- 1) Remove stator assembly (20) from pump and stator shaft assembly (19).

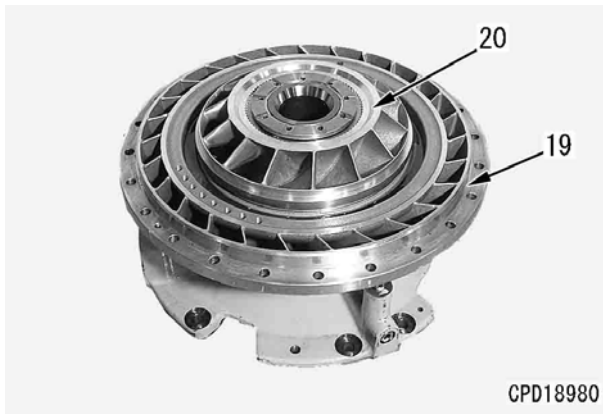

- 2) Remove snap ring (21) from stator (20a) and remove freewheel assembly (22).
- 3) Remove outer race (23), 2 bushings (24), 2 balls (25), and freewheel (26) from free-wheel assembly (22).
 - ★ Take care not to lose balls (25).

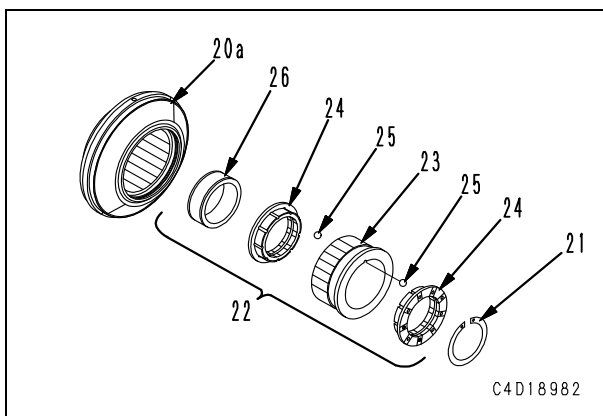
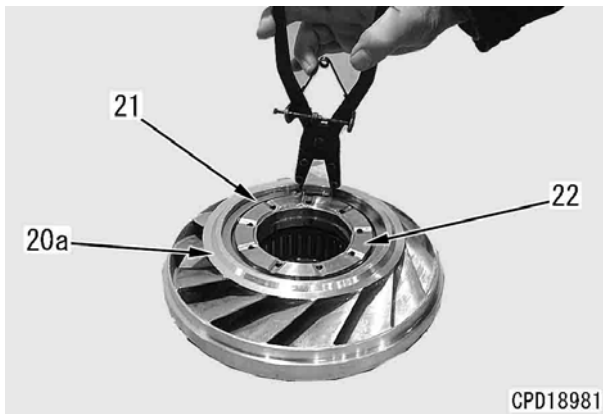

5. Pump and stator shaft assembly

- 1) Using tool D9, remove nut (27) from pump and stator shaft assembly (19).
 - ★ Using a bar or others, lock housing (28).

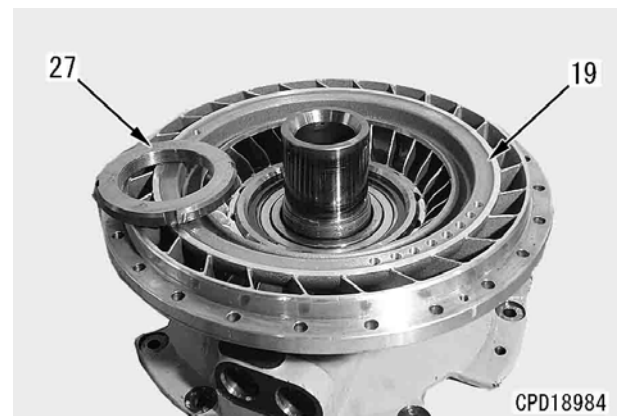
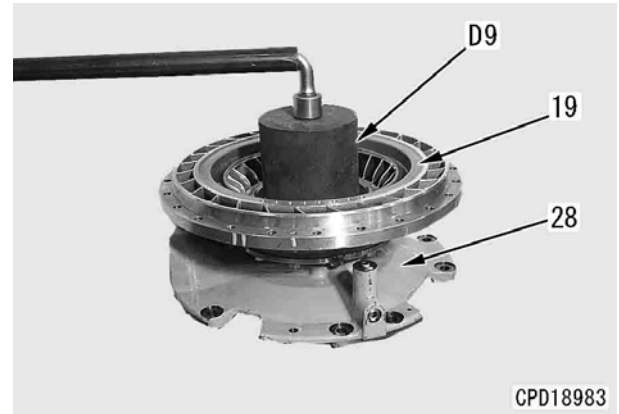

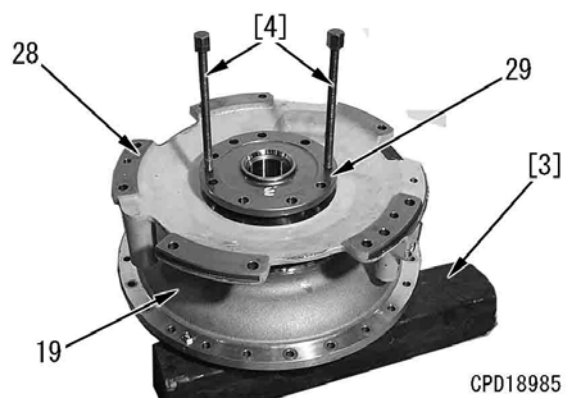

- 2) Reverse pump and stator shaft assembly (19) and set it to block [3].
- 3) Remove the mounting bolts and then remove stator shaft (29) by using forcing screws [4].
- 4) Remove housing (28).
- 5) Remove inner races (30a) and (30b) from stator shaft (29).

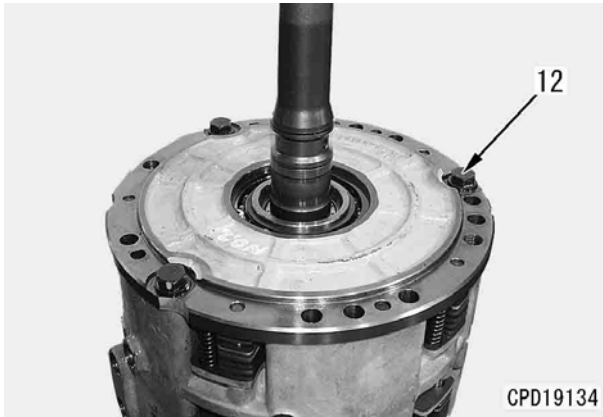

4. Input shaft, front cover and No. 1 carrier assembly

- 1) Remove remaining 3 through bolts (12).
 - ★ When loosening through bolts (12), do not use an impact wrench which can damage the vibration control sleeve.



- 2) Sling and remove input shaft, front cover, and No. 1 carrier assembly (13).
 -  Input shaft, front cover, and No. 1 carrier assembly (13): **35 kg**

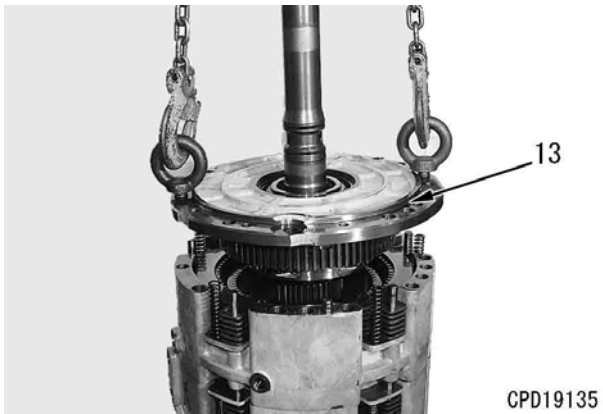

5. Disassembly of input shaft, front cover and No. 1 carrier assembly

- 1) Remove snap ring (14), No. 2 sun gear (15) and snap ring (16).
- 2) Remove snap ring (17) and No. 1 sun gear (18).

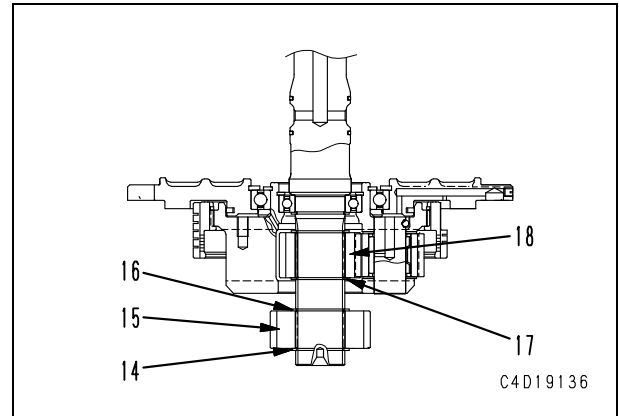

- 3) Remove snap ring (19).

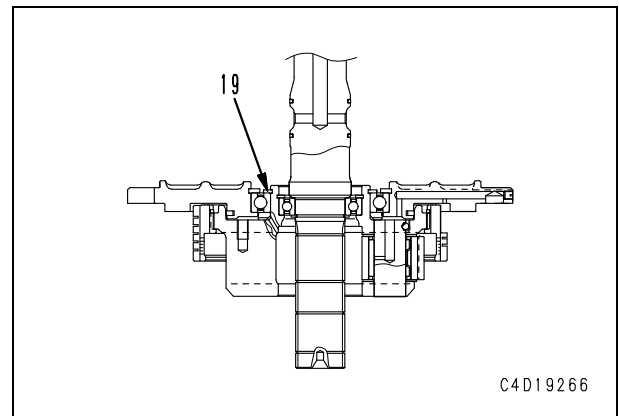

- 4) Set front cover (20) to blocks [4].
- 5) Using tool **D20**, remove input shaft and No. 1 carrier assembly (21) and spacer (21a).

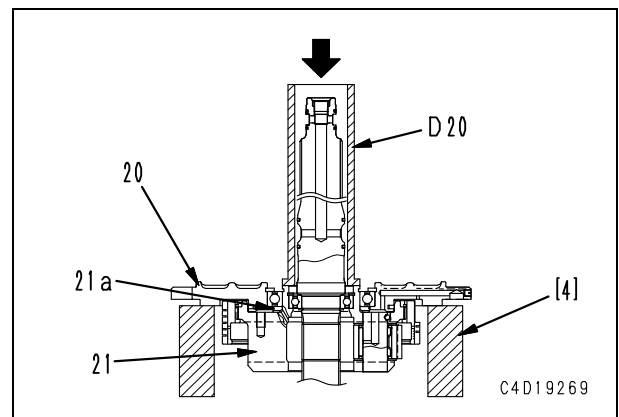

- 6) Using push tool [9], remove spacer (140) and bearing (141) as an assembly from No. 5 housing assembly (132).

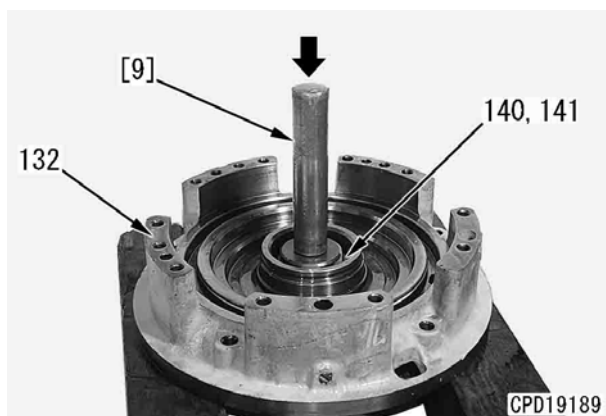

- 7) Remove bearing (141) from spacer (140).

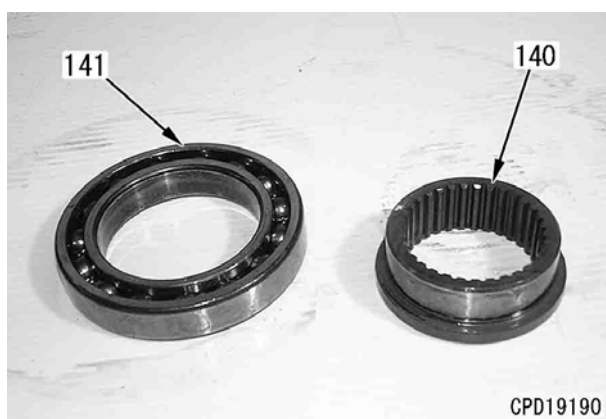

- 8) Remove seal ring (142) from No. 5 housing (132).

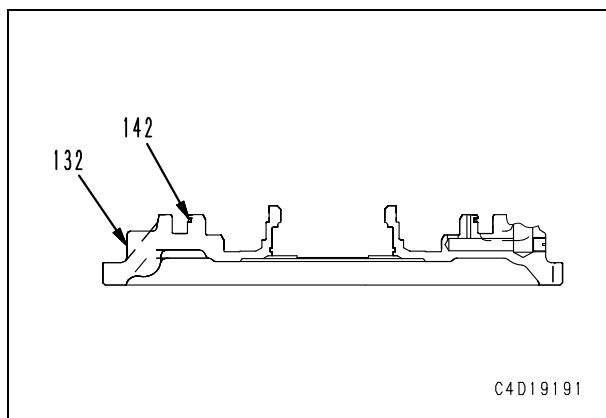

Assembly

● Precautions for assembly

- ★ Clean each part thoroughly and confirm that it is free from dirt and flaw.
- ★ Apply power train oil (For details, see “Table of fuel, coolant and lubricants”) to the sliding surfaces of each part before installing.
- ★ After press fitting each bearing, drip power train oil (For details, see “Table of fuel, coolant and lubricants”) onto its rotating parts and rotate it about 10 turns.
- ★ Check that the snap ring is securely in the groove.
- ★ When installing piston seal ring (a), set pressure receiving side (b) toward housing (c) as shown in the figure.
- ★ When installing the metallic seal ring, apply grease (G2-LI) to it and install evenly, taking care not to shift it in any direction.

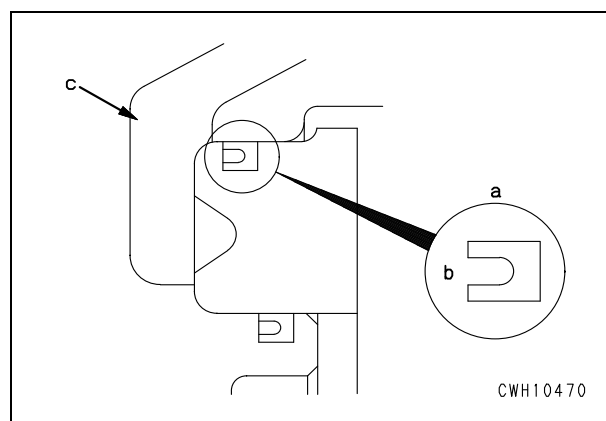

1. Assembly of No. 5 housing assembly

- 1) Set No. 5 housing (132) to blocks [10].
 No. 5 housing (132): 30 kg

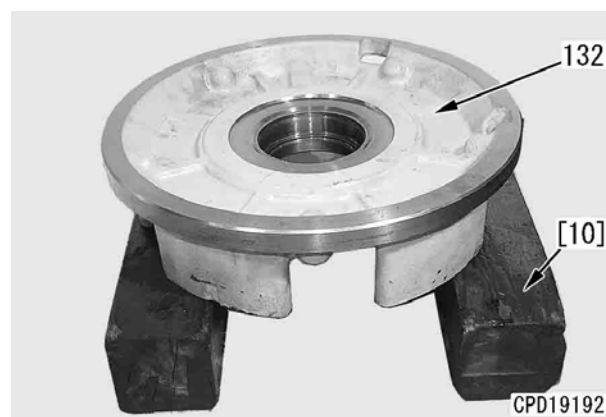

26. Assembly of No. 1 carrier assembly

- 1) Install bearing (31) to planetary gear (32), set thrust washers (30) on its both sides, and set it to No. 1 carrier (24).
- 2) Set ball (29) to shaft (28) and install it to No. 1 carrier (24). (4 places)

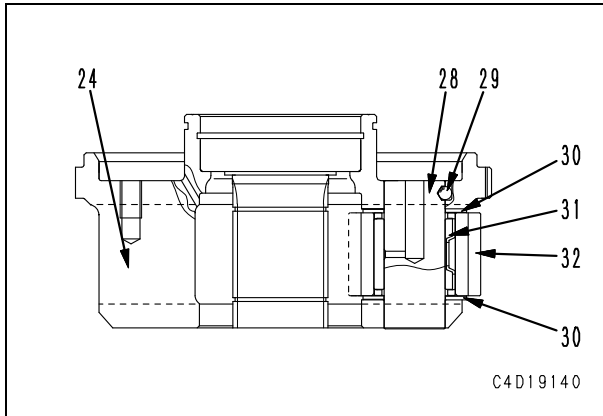

27. Assembly of input shaft and No. 1 carrier assembly

- 1) Set No. 1 ring gear (26) to No. 1 carrier assembly (24) and install snap ring (25).



- 2) Install bearing (38) to input shaft (23).
- 3) Install 2 seal rings (35) and (36) each and snap rings (38a) and (37).

Seal rings (35) and (36):

Grease (G2-LI)

Transmission side spline portion (e):

Grease (LM-G) or molybdenum disulfide lubricant (LM-P)

★ Do not coat grease to the torque converter side spline portion (f).

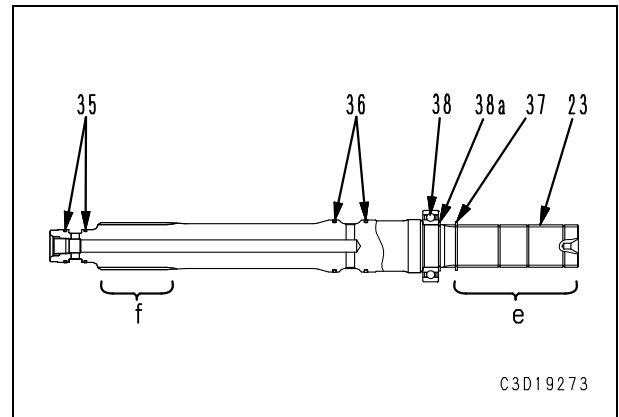

- 4) Install input shaft (23) to No. 1 carrier assembly (24) and install snap ring (22).

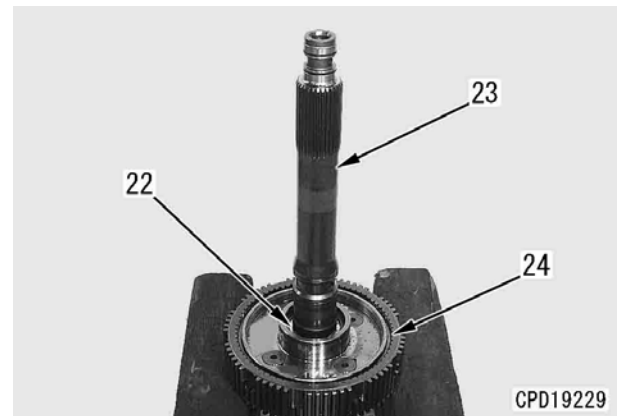

- 5) Install No. 1 sun gear (18) and snap ring (17) to input shaft (23).
- 6) Install snap ring (16), No. 2 sun gear (15) and snap ring (14).

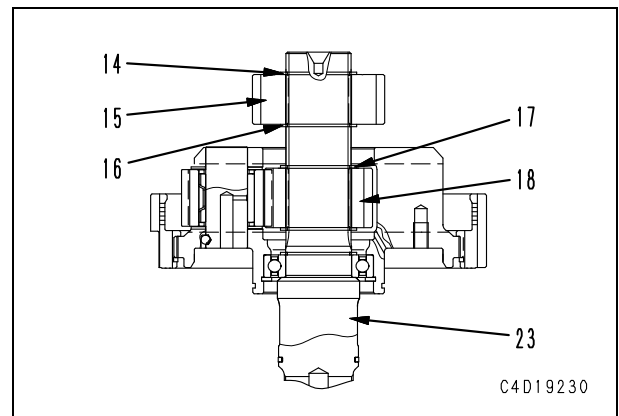

- 3) Drive roll pin (65) into the shaft.
- 4) Pull out shaft (66) and remove gear (52), thrust washer (67), and bearing (69).
 - ★ Pull roll pin (65) out of the shaft.

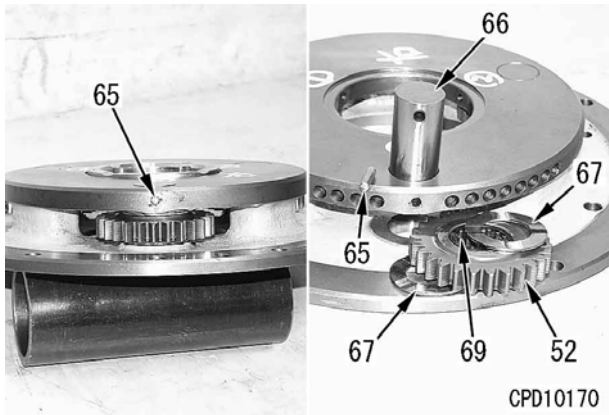

- 5) Remove bushing (91) from carrier (90).

8. Sun gear

- 1) Remove snap ring (70) and collar (73).

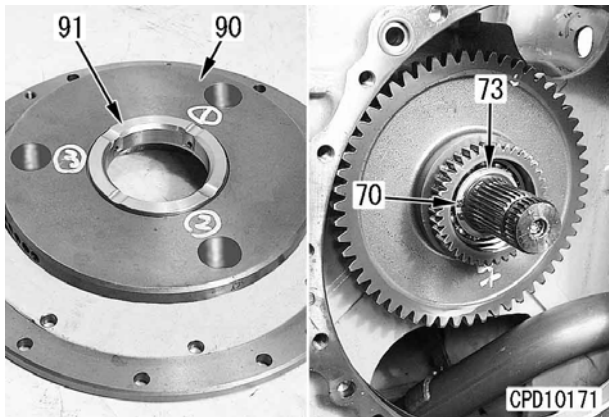

- 2) Using gear puller [8], remove sun gear (72) and bearing (98).

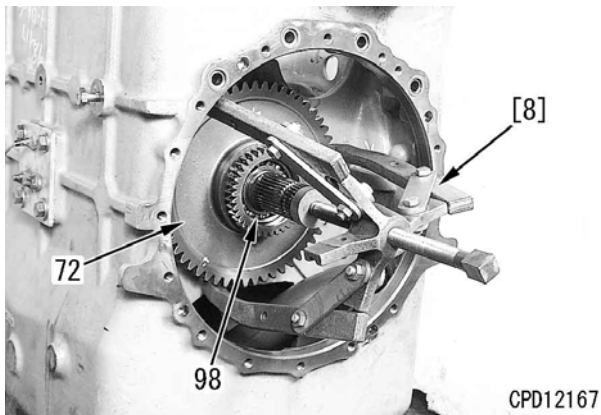

- 3) Using the bearing race puller, remove bearing (74).
- 4) Remove collar (71).
- 5) Remove snap ring (93).
 - ★ Only the right side of the machine.

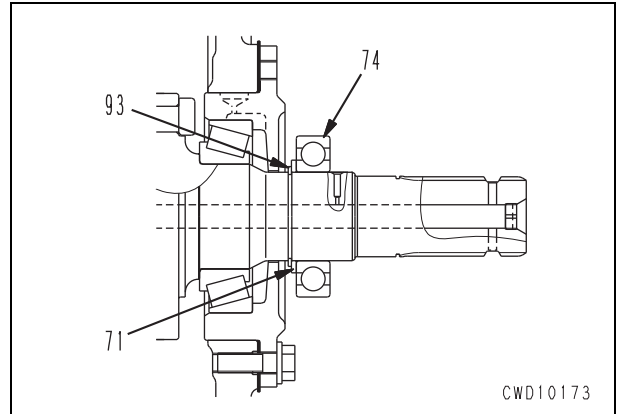

9. Bevel pinion assembly

- 1) Remove the mounting bolts.
- 2) Using guide bolts [9] and forcing screws [10], remove bevel pinion assembly (95) and shim (96).
 - ★ Check and record the quantity and thickness of the shims.

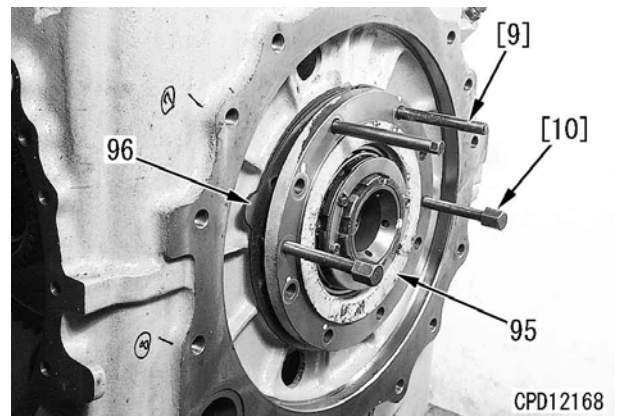

- 3) Disassembly of bevel pinion assembly
 - 1) Remove bolt (97), plate (99), and pin (100).

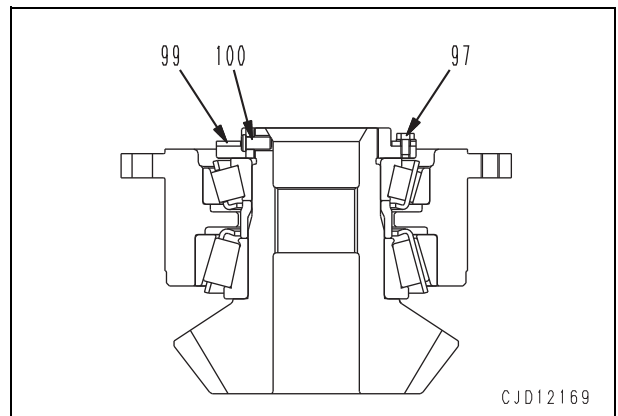

- 6) Set brake drum (45) to hub (39).
- 7) Install discs (46), plates (47), and springs (48).

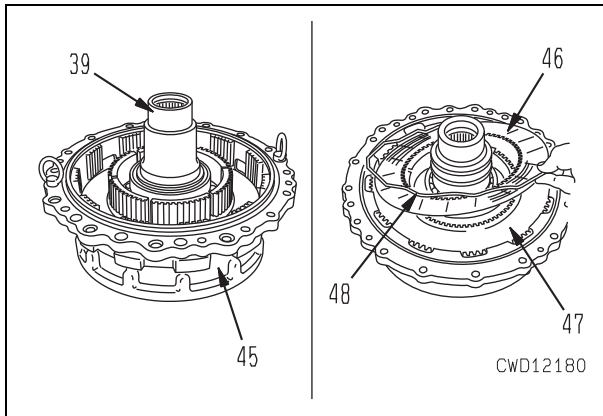

- 8) Install seal rings (27) and (53) and cage (51).
 - ★ Roughly match the oil holes on the cage to the 4 oil holes on the drum.
 - ★ Press fit the cage to the outer race side of the bearing.

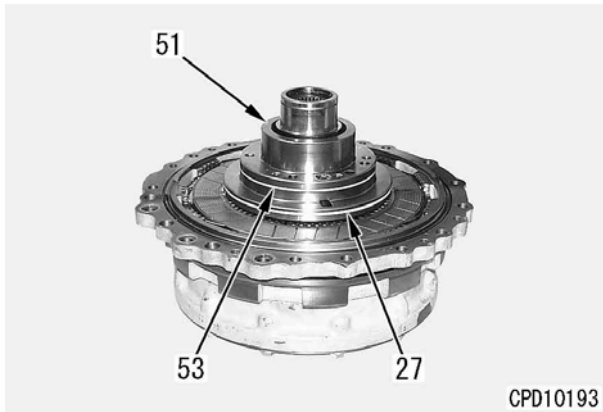

- 9) Install the seal ring to piston (43).
- 10) Install piston (43) to the drum, while setting match mark (a) of the former to the center of 13.5 mm hole (c) of the latter.
 - (b): Spot facing of piston
 - (d): Opposite side to side hole of drum

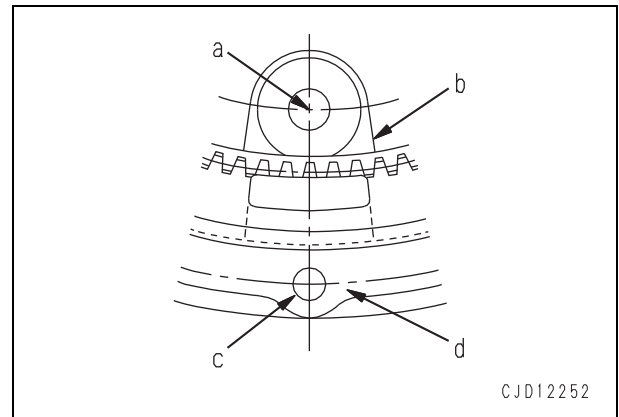
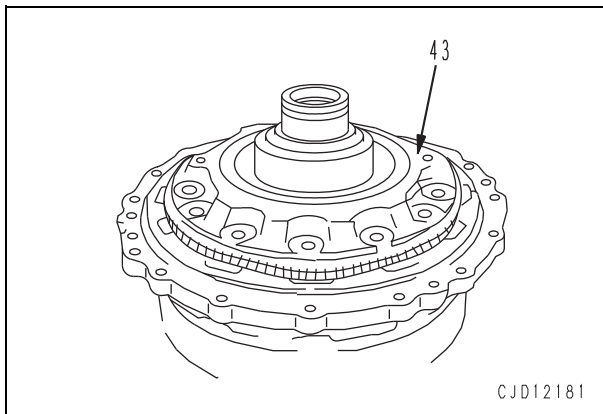

- 11) Install spring (42).
- 12) Install guide bolt [14] to cage (51).
- 13) Install bearing (60) to cover (41).

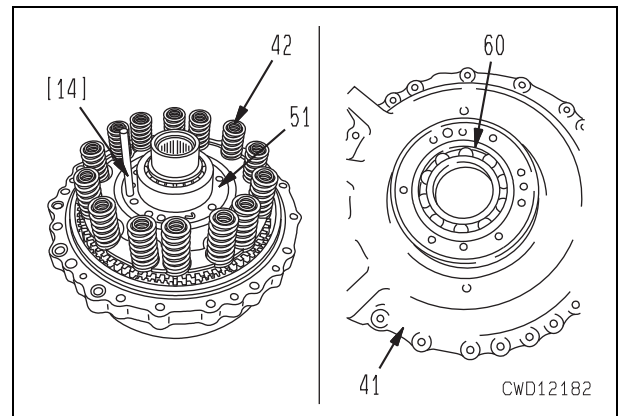

- 14) Using eyebolts [15] and matching to the guide bolt, set cover (41).
 - ★ Check that the spring is fitted securely to both of the piston and case.
- 15) Compressing the spring with forcing screws [17] and nuts [16], press fit the inner race side of the bearing to the hub assembly.

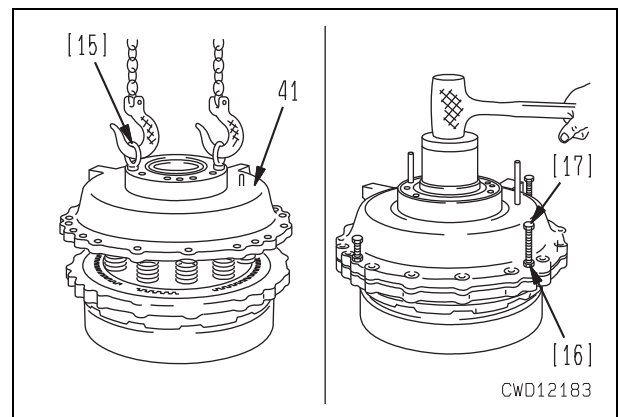

- 5) Remove bearing (7) from shaft (6).
- 6) Remove outer race (8) from gear (5).

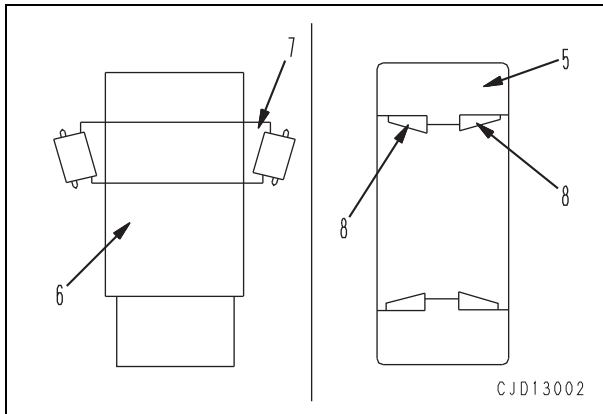

3. Shaft

Using eyebolt [4], remove shaft (9).

4. Ring gear, housing assembly

- 1) Remove holder (10).

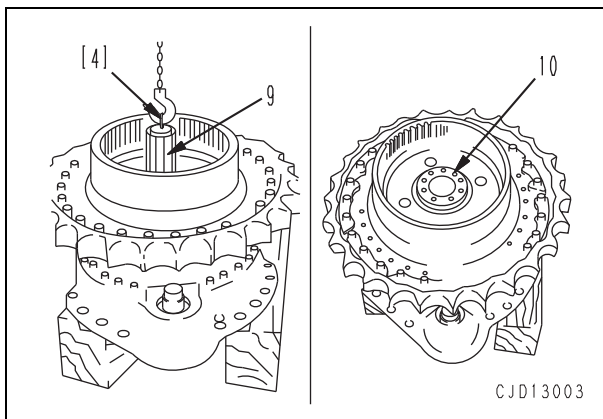

- 2) Using eyebolts [5], remove ring gear and hub assembly (11).
- 3) Remove snap ring (12), then remove ring gear (14) from hub (13).

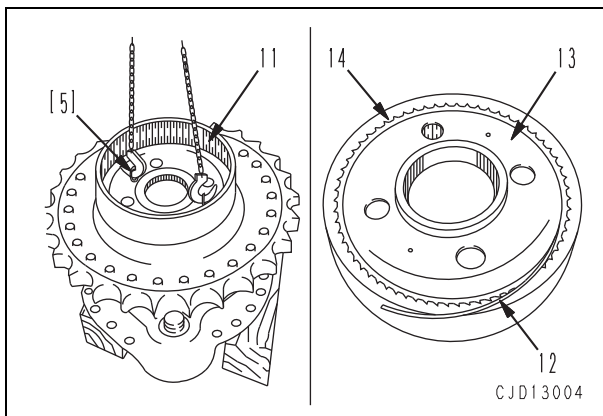

5. Sprocket, hub assembly

- 1) Fit eyebolts, pull out sprocket and hub assembly (15) with tool J2, and remove.

★ Bearing (19) will come out at the same time.

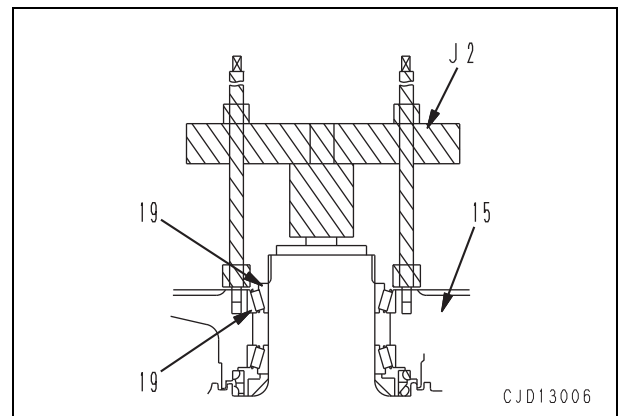
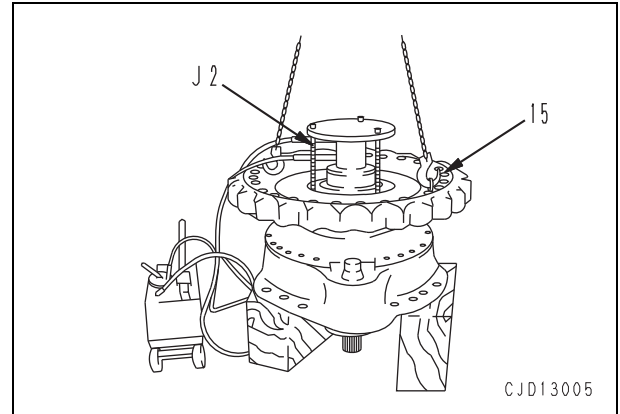

- 2) Remove floating seal (16).
★ If it is to be used again, be careful not to damage the seal surface and keep it in a safe place.
- 3) Remove outer race (18).

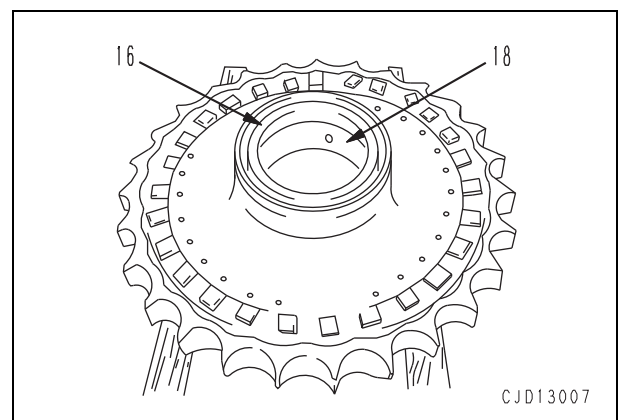

- 4) Remove two bearing outer races (25c) from the planetary gear.

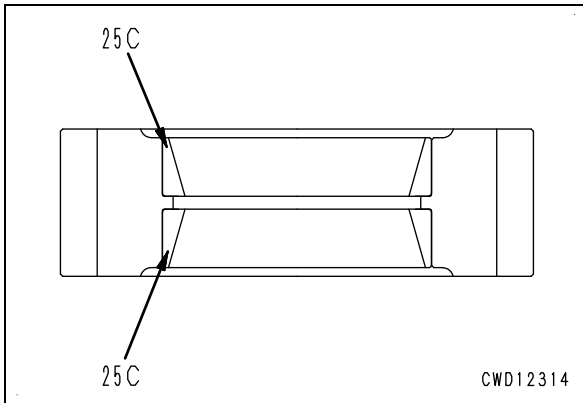

- 3) Using eyebolts, remove gear (29).



5. Hub and case assembly

- 1) Remove thrust washer (26) and sun gear (27).

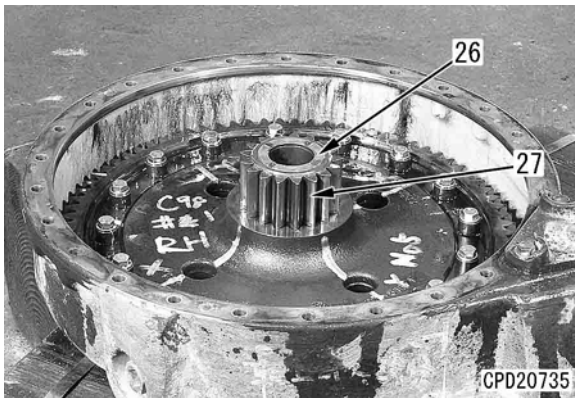

- 4) Remove mounting bolts (30) and plate (31).

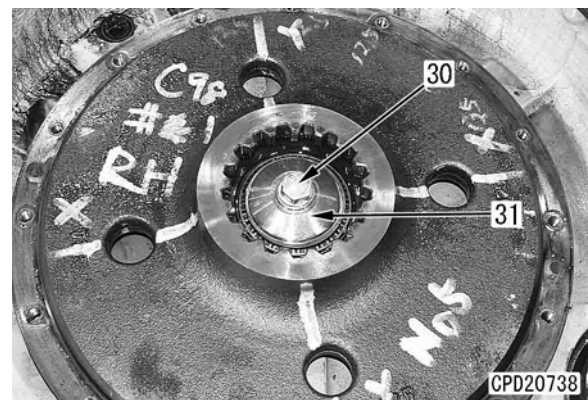

- 2) Remove gear mounting bolts (28).

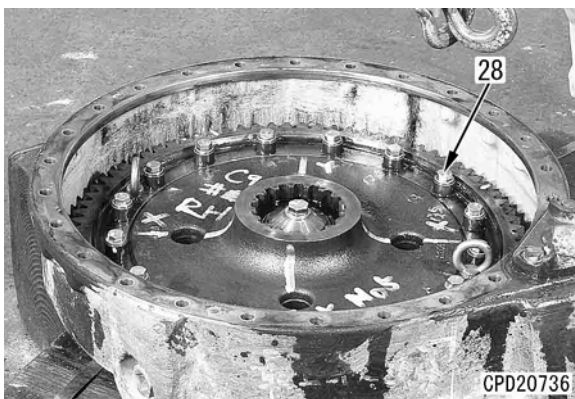

- 5) Using tool J10, separate hub assembly (32) from the case.



7. Shaft

Install the O-ring to the sprocket hub assembly side. Using eyebolts, install shaft (2).

 Mounting bolt:

490 - 608 Nm {50 - 62 kgm}

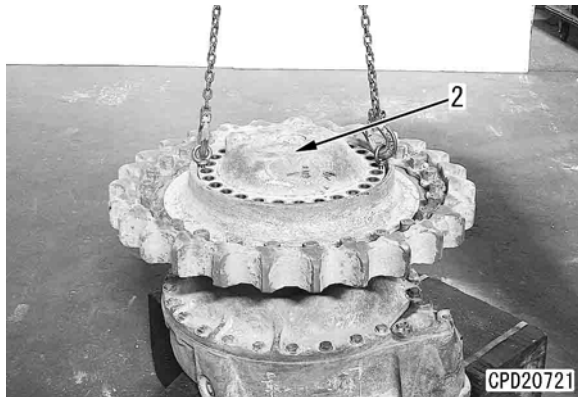

- **Refilling of oil**

Tighten the drain plug and supply oil through the oil filler port to the specified level.

- ★ After installing the final drive assembly to the chassis, check the oil level finally.

 Final drive case

D65EX-16: 21 ℓ

D65PX-16: 25 ℓ

 Oil filler and drain plug:

127 - 176 Nm {13 - 18 kgm}

 Oil level detection port plug:

58.8 - 76.4 Nm {6 - 8 kgm}

CLICK HERE TO **DOWNLOAD** THE COMPLETE MANUAL

- Thank you very much for reading the preview of the manual.
- You can download the complete manual from: www.heydownloads.com by clicking the link below



- Please note: If there is no response to CLICKING the link, please download this PDF first and then click on it.

CLICK HERE TO **DOWNLOAD** THE COMPLETE MANUAL