

# Shop Manual

BULLDOZER

***D375A-8***

SERIAL NUMBERS 80001 and up

**KOMATSU**

CLICK HERE TO **DOWNLOAD** THE COMPLETE MANUAL

- Thank you very much for reading the preview of the manual.
- You can download the complete manual from: [www.heydownloads.com](http://www.heydownloads.com) by clicking the link below



- Please note: If there is no response to CLICKING the link, please download this PDF first and then click on it.

CLICK HERE TO **DOWNLOAD** THE COMPLETE MANUAL

- Always wear the protective eyeglasses when hitting parts with a hammer.
- Always wear the protective eyeglasses when grinding parts with a grinder, etc.
- When performing any operation with multiple workers, always agree on the operating procedure before starting. Be clear in verbal communication, and observe hand signals. Hang "UNDER REPAIR" warning tag in the operator's compartment Before starting work.
- Work and operation which require license or qualification should be performed by qualified workers.
- Welding repairs should be performed by trained and experienced welders. When performing welding work, always wear welding gloves, apron, welding goggles, cap and other clothes suited for welding work.
- Warm up before starting the work with exercise which increases alertness and the range of motion in order to prevent injury.
- Avoid prolonged work, and take a rest at times to keep up a good condition. Take a rest at designated safe area.

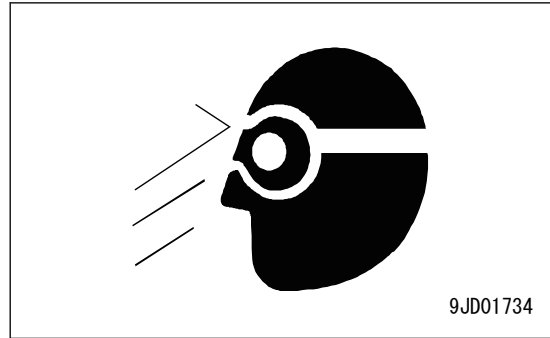

### Precautions for preparatory work

- Place the machine on a firm and level ground, and apply the parking brake and chock the wheels or tracks to prevent the machine from moving before adding oil or making any repairs.
- Lower the work equipment (blade, ripper, bucket, etc.) to the ground before starting work. If this is not possible, insert the lock pin or use blocks to prevent the work equipment from falling. In addition, be sure to lock all the control levers and hang "UNDER REPAIR" warning tag on them.
- When performing the disassembling or assembling work, support the machine securely with blocks, jacks, or stands before starting the work.
- Remove all mud and oil from the steps or other places for going up and down on the machine. Always use the handrails, ladders or steps when for going up and down on the machine. Never jump on or off the machine. When the scaffold is not provided, use steps or stepladder to secure your footing. Do not use handrails, ladders, or steps if they are damaged or deformed. Repair it or replace it immediately.

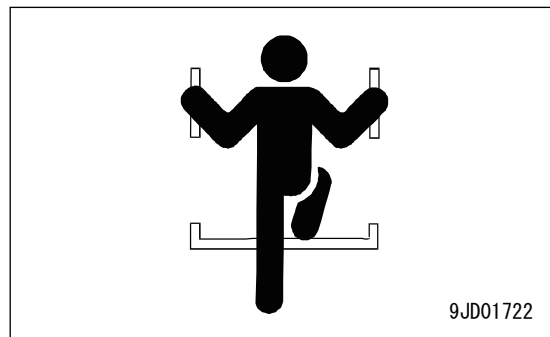

### Precautions during work

- For the machine with the battery disconnect switch, check before starting the work that the system operating lamp is not lit. Then, turn the battery disconnect switch to OFF (○) position.

#### REMARK

Remove the key after it is turned to OFF (○) position if the battery disconnect switch is a switch key type. For the machine without the battery disconnect switch, turn the starting switch to OFF position, wait for two minutes or more before starting the work. Disconnect the battery cable by starting from the negative (-) terminal first.

- For the machine with the quick release battery terminal (-), check before starting the work that the system operating lamp is not lit. Then, disconnect the quick release battery terminal (-).

#### REMARK

For the machine without the system operating lamp, turn the starting switch to OFF position, wait for two minutes or more before starting the work. Disconnect the quick release battery terminal (-).

## METHOD FOR DISCONNECTING AND CONNECTING DEUTSCH CONNECTOR

### Method for disconnecting Deutsch connector

While pressing locks (a) and (b) from each side respectively, pull out female connector (2).

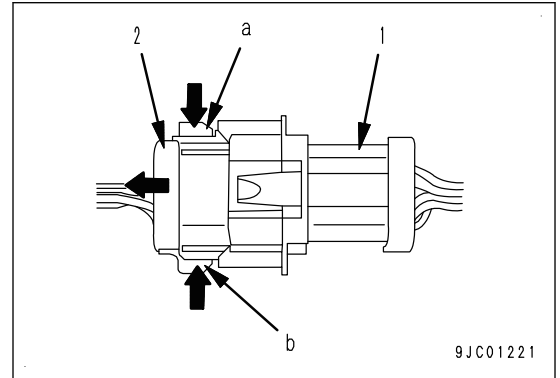

### Method for connecting Deutsch connector

1. Push in female connector (2) horizontally, and insert it straight until it clicks. (Arrow: x)
2. In order to check whether locks (a) and (b) are completely inserted, insert female connector (2) by rocking it vertically (in the arrow z direction). (Arrow: x, y, z)

#### REMARK

Lock (a) in the figure is pulled down (not set completely), and lock (b) is set completely.

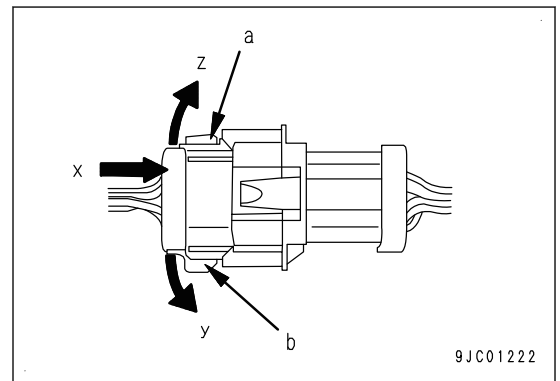

Abbreviation	Actual word spelled out
S/T	Steering
STRG	
SIG	Signal
SOL	Solenoid
STD	Standard
OPT	Option
OP	
PRESS	Pressure
SPEC	Specification
SW	Switch
TEMP	Temperature
T/C	Torque Converter
T/M	Transmission

## ENGINE CONTROL SYSTEM

### LAYOUT OF ENGINE CONTROL SYSTEM

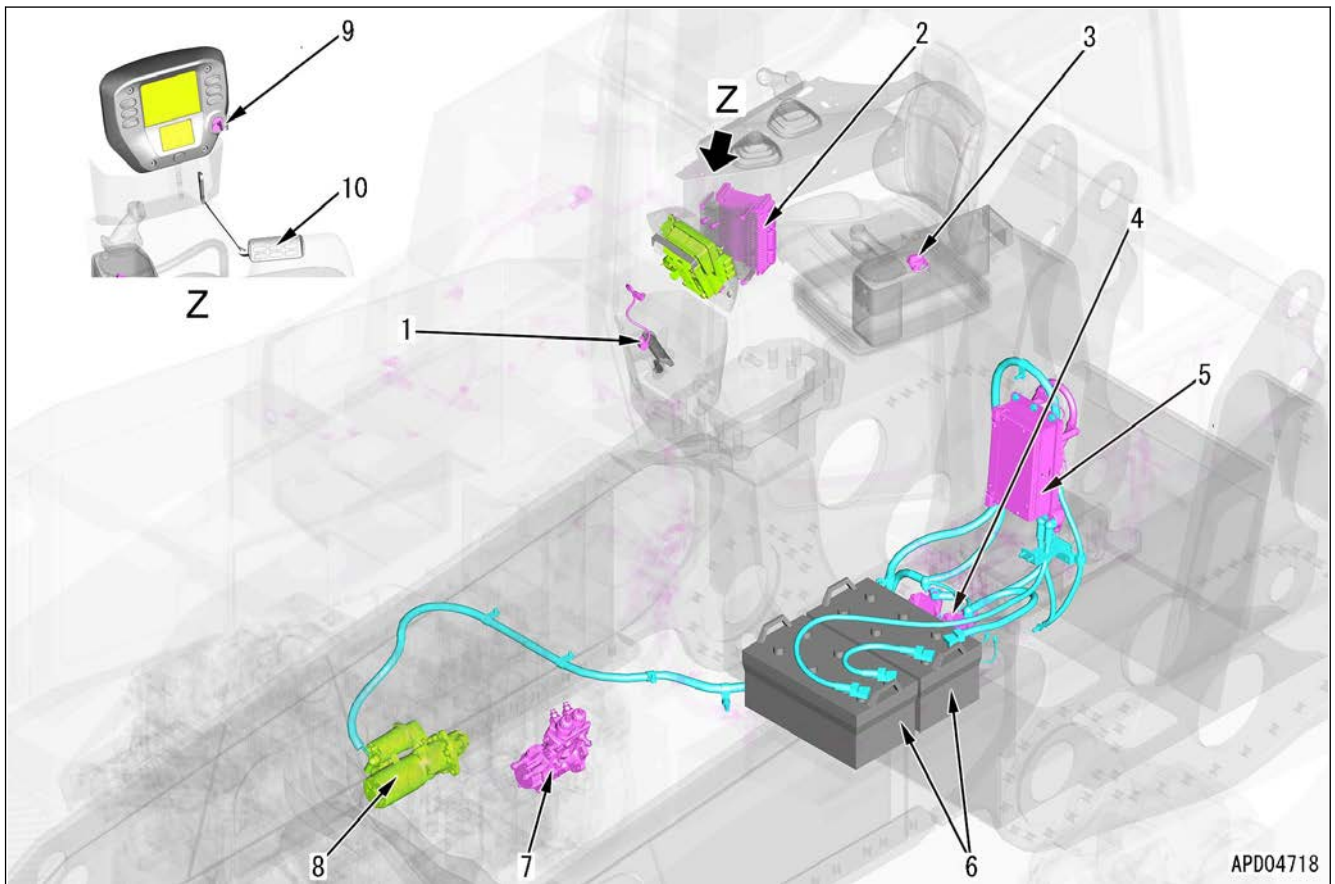

1: Decelerator pedal potentiometer

2: Power train controller

3: Fuel control dial

4: Battery relay

5: Battery isolator switch, starting motor isolator switch

6: Battery

7: Fuel supply pump

8: Starting motor

9: Starting switch

10: Decelerator pedal

- The throttle signals of the fuel control dial are sent to the power train controller and processed together with the 3rd throttle signal, and then sent as the throttle commands together with the throttle signals of the decelerator pedal to the engine controller.
- The engine controller controls the engine corresponding to the commands.

# COOLING SYSTEM

## LAYOUT DRAWING OF COOLING SYSTEM

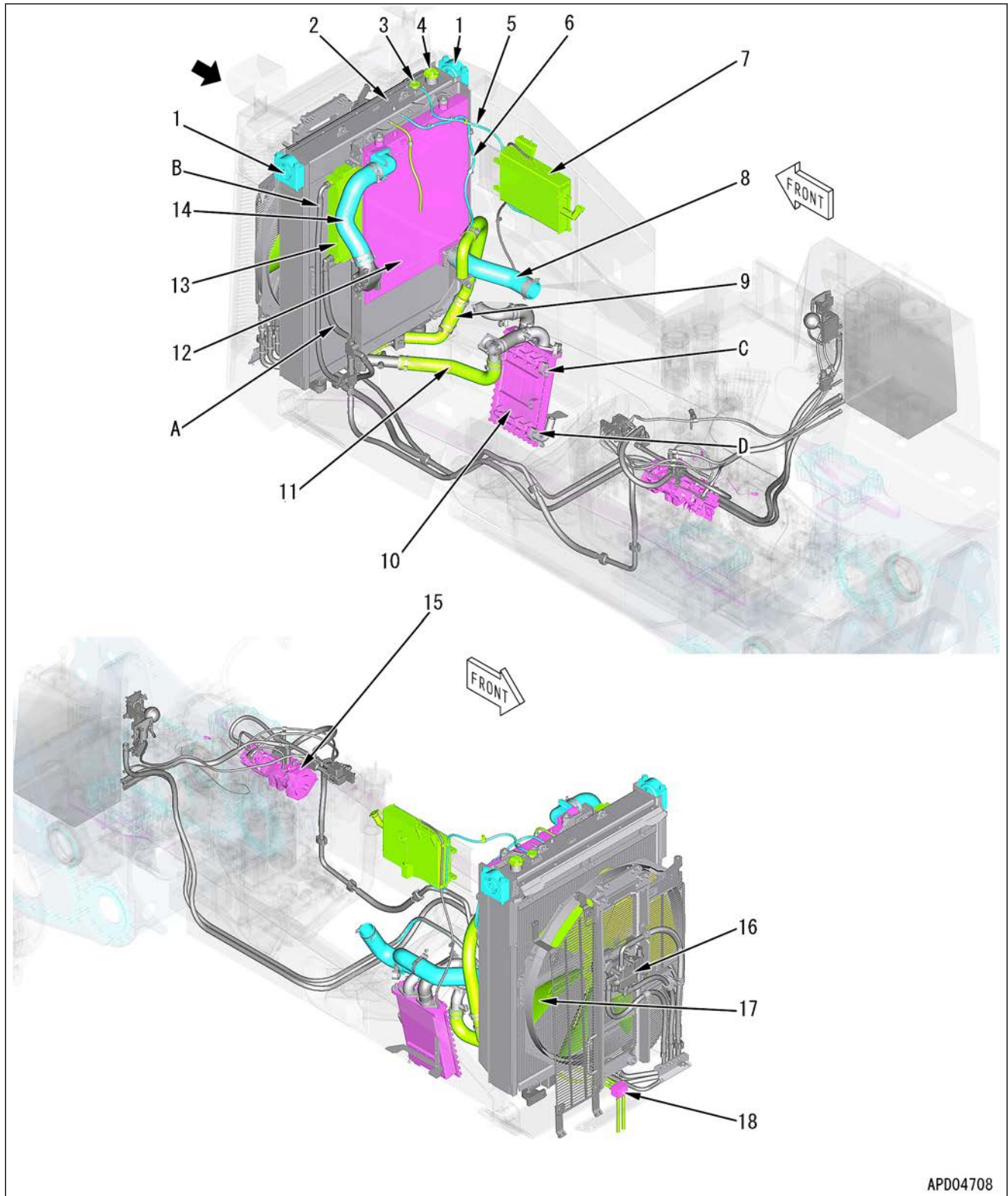

APD04708

- A: Hydraulic oil cooler inlet
- B: Hydraulic oil cooler outlet
- 1: Cushion

- C: Power train oil cooler inlet
- D: Power train oil cooler outlet
- 2: Radiator assembly

**Others**

Contents and conditions of processing	Method	Transmittance of signals
Pre-defined Monitoring Self-define Monitoring Abnormality Record Maintenance Record Maintenance Mode Setting Phone Number Entry Default Diagnostic Tests Adjustment No-Injection Cranking KOMTRAX Settings Service Message	-	-

**REMARK**

For details of the operating method, see TESTING AND ADJUSTING, "SET AND OPERATE MACHINE MONITOR".

Pin No.	Signal name	Input and output signals
15	Alternator R signal	Input
16	Sensor power supply (+24 V)	Output
17	(*1)	-
18	Forward travel switch	Input
19	Right steering lever potentiometer (sub)	Input
20	Left steering lever potentiometer (main)	Input
21	GND (analog)	-
22	Sensor power supply (5 V)	Output
23	Pre-lub oil pressure switch	Input
24	Neutral switch	Input

\*1: Never connect these pins, otherwise it may cause malfunctions or failures.

### **DRC26-40P(A) “PTCN2”**

Pin No.	Signal name	Input and output signals
1	Sensor power supply (5 V)	Output
2	Lockup clutch fill switch	Input
3	Selection of lever specification	Input
4	RS232C RXD	Input
5	Transmission forward clutch fill switch	Input
6	Brake left fill switch	Input
7	Upshift switch	Input
8	Neutral safety relay	Output
9	(*1)	-
10	(*1)	-
11	Pre-lubrication motor relay	Output
12	Stator clutch fill switch	Input
13	Selection of lever specification	Input
14	RS232C TXD	Output
15	Transmission 3rd clutch fill switch	Input
16	Steering clutch right fill switch	Input
17	Downshift switch	Input
18	(*1)	-
19	Fan reverse solenoid	Output
20	(*1)	-
21	Preheater relay	Output
22	CAN0_L(KOMNET/c)	Input and output
23	CAN1_L(KOMNET/r)	Input and output
24	External starting signal	Input

- PA: Pump discharge port
- PB: Pump pressure inlet port
- PD1: Case drain port
- PD2: Drain plug
- PD3: Drain port
- 1: Front pump

- PEN: Control pressure pickup port
- PLS: Load pressure input port
- PLSC: Load pressure pickup port
- PS: Pump suction port
- 2: LS valve

**Sectional view**

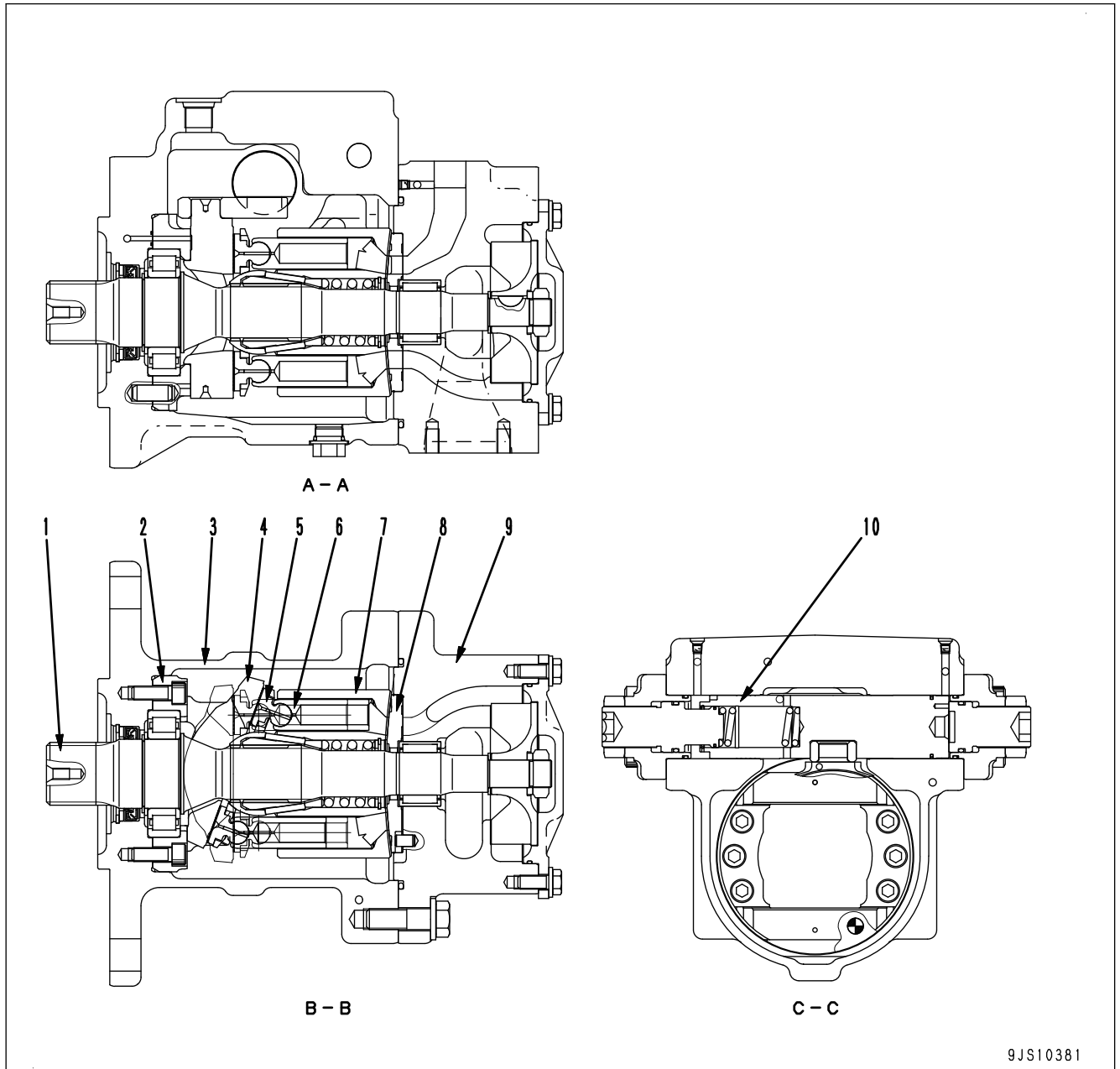

9JS10381

- |  |  |
|--|--|
| <ul style="list-style-type: none"> <li>1: Shaft</li> <li>2: Cradle</li> <li>3: Case</li> <li>4: Rocker cam</li> <li>5: Shoe</li> </ul> | <ul style="list-style-type: none"> <li>6: Piston</li> <li>7: Cylinder block</li> <li>8: Valve plate</li> <li>9: End cap</li> <li>10: Servo piston</li> </ul> |
|--|--|

## OPERATION OF POWER TRAIN SYSTEM

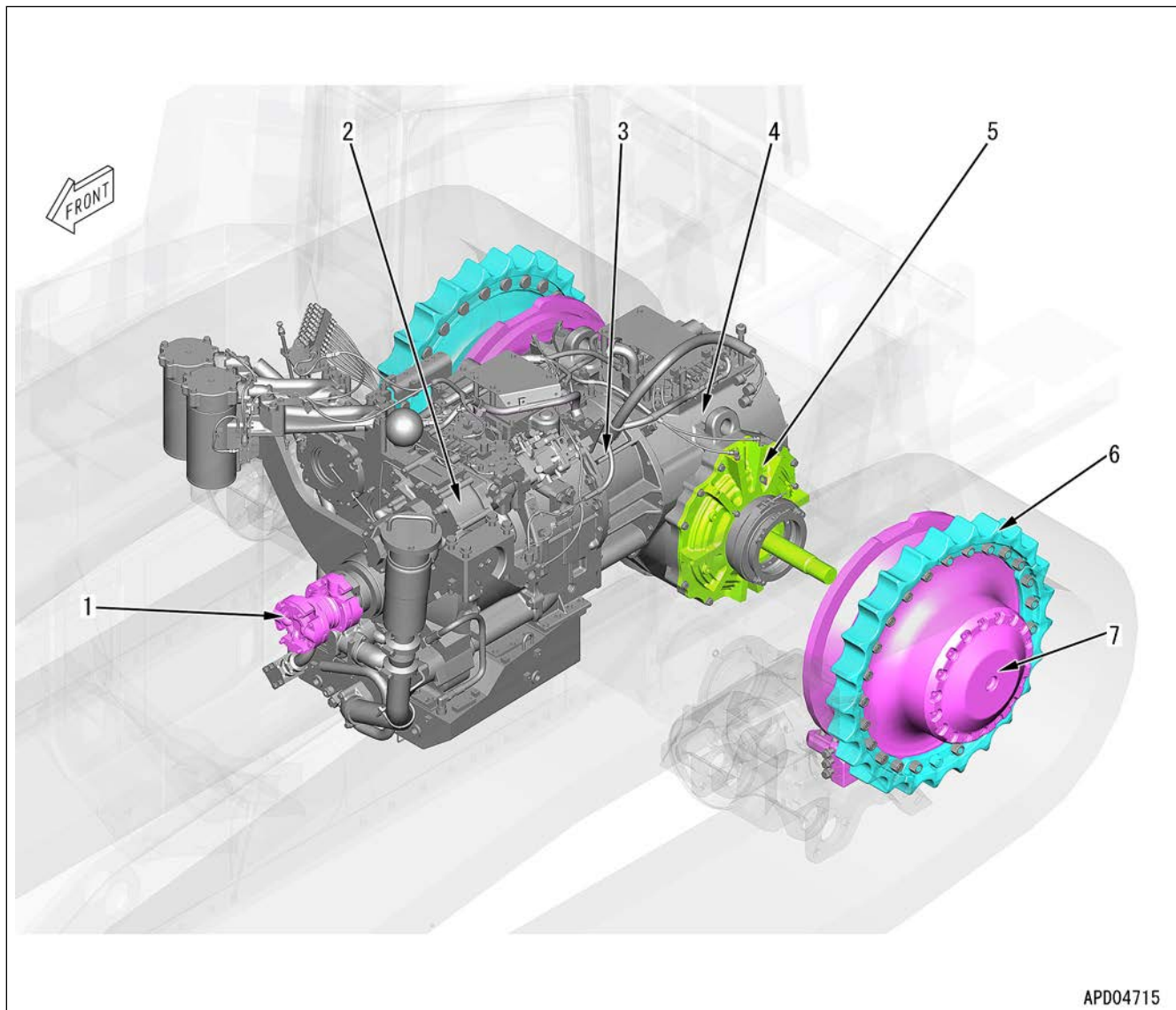

APD04715

1. The power generated by the engine is sent from universal joint (1) to torque converter (2) after its torsional vibrations have been reduced with damper.
2. The power from the engine is sent through the oil by torque converter (2) to the transmission input shaft (turbine shaft) corresponding with the change in load.
3. Transmission (3) performs deceleration and gear shift using a combination of planetary gear mechanisms and hydraulic clutches (three forward speeds and three reverse speeds). Two clutches are selected and engaged corresponding to the change in load, and the power from the bevel pinion at the rear end of the transmission is sent to the bevel gear fixed to the bevel gear shaft (4).
4. Steering clutch and brake (5) is used for braking the machine and steering it. Steering brake (5) is a wet, multiple disc clutch and spring boosted type. The power output from steering clutch and brake (5) is sent to final drive (9).
5. Final drive (7) reduces the speed with a single-stage spur gear and a single-stage planetary gear system. It rotates sprocket (6) to drive the track shoe and move the machine.

A: 1st clutch oil pressure pickup port (1ST)  
B: 3rd clutch oil pressure pickup port (3RD)  
C: R clutch oil pressure pickup port (R)  
1: Transmission control valve  
2: Front case

D: 2nd clutch oil pressure pickup port (2ND)  
E: F clutch oil pressure pickup port (F)  
  
3: Rear case  
4: Lubricating oil relief valve

Sectional view

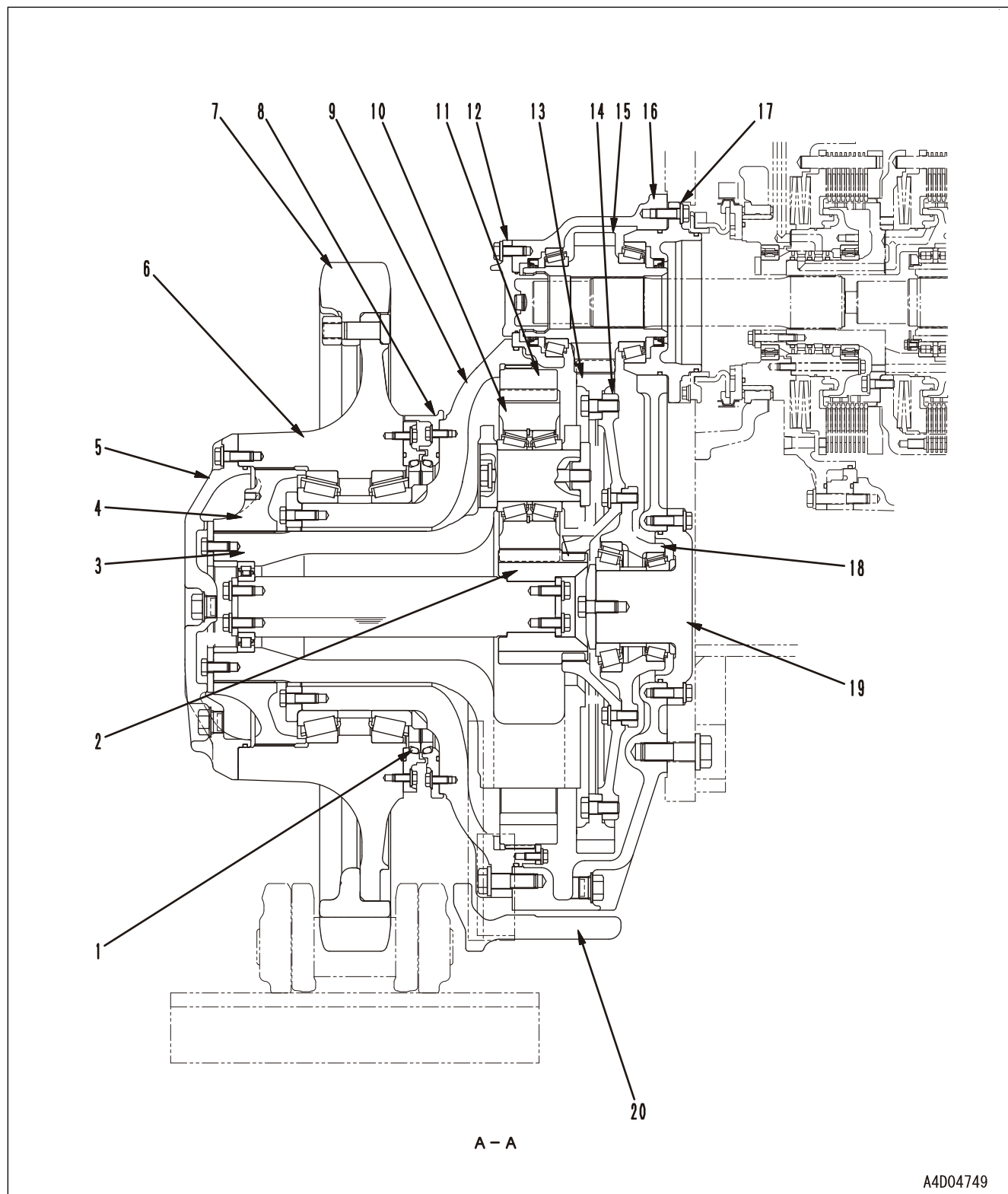

- 1: Floating seal
- 2: Sun gear
- 3: Carrier
- 4: Sprocket hub
- 5: Cover

- 6: Sprocket boss
- 7: Sprocket teeth
- 8: Floating seal guard
- 9: Cover
- 10: Planetary pinion

A4D04749

## COMPONENT PARTS OF LIFTING SYSTEM

### SWITCH BOX

#### STRUCTURE OF SWITCH BOX (GROUND SIDE)

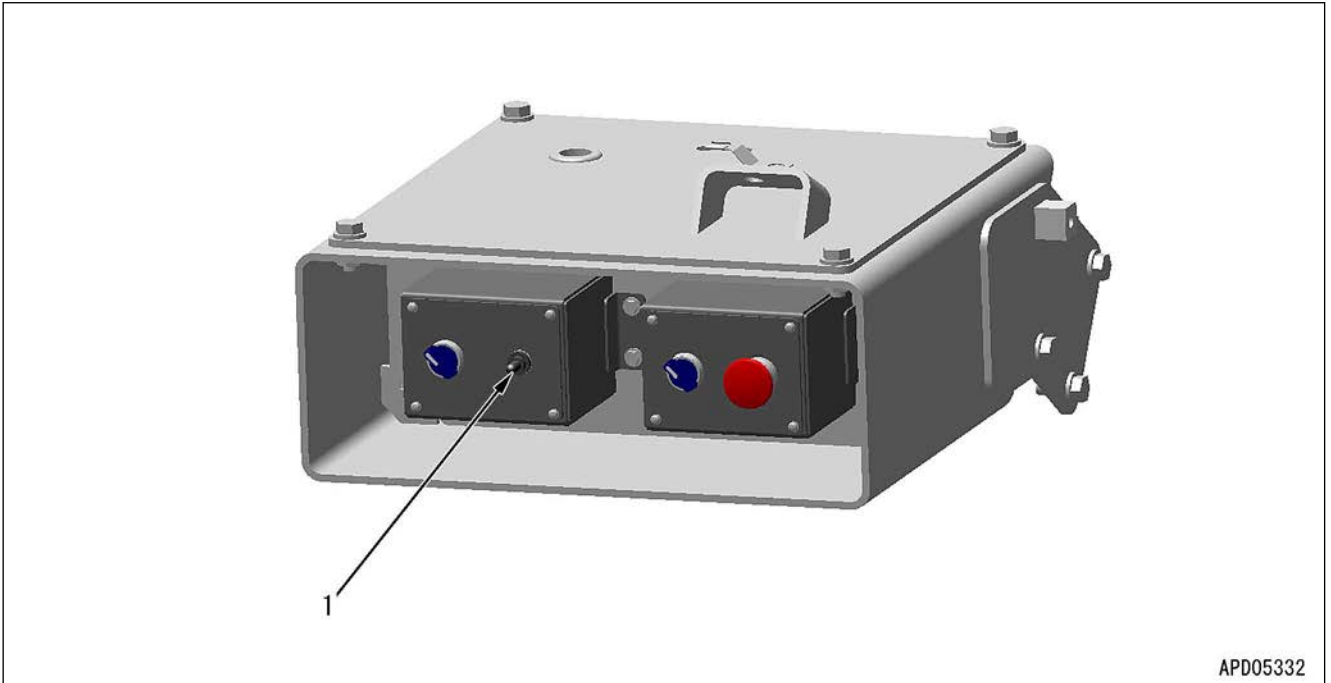

1: Ladder raise/lower switch

#### OPERATION OF SWITCH BOX (GROUND SIDE)

1. Ladder is raised while the ladder raise/lower switch (1) is turned upward.
2. Ladder is lowered while the ladder raise/lower switch (1) is turned downward.

#### STRUCTURE OF SWITCH BOX (MACHINE SIDE)

- 1: Ladder raise switch
- 2: Ladder lower switch

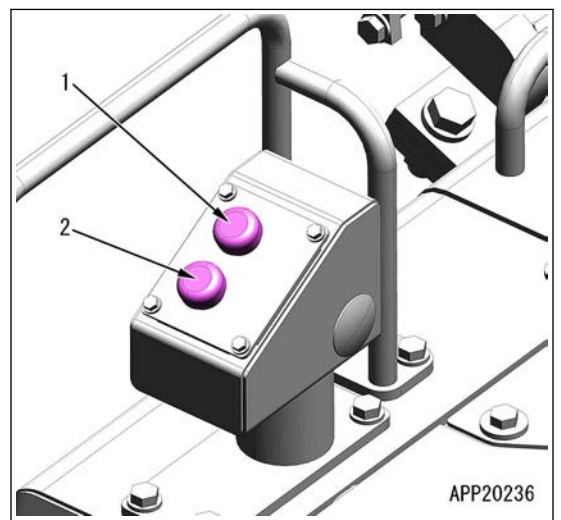

#### OPERATION OF SWITCH BOX (MACHINE SIDE)

1. Ladder is raised while the ladder raise switch (1) is pressed.
2. Ladder is lowered while the ladder lower switch (2) is pressed.

Abbreviation	Actual word spelled out
S/T	Steering
STRG	
SIG	Signal
SOL	Solenoid
STD	Standard
OPT	Option
OP	
PRESS	Pressure
SPEC	Specification
SW	Switch
TEMP	Temperature
T/C	Torque Converter
T/M	Transmission

Fig. 9

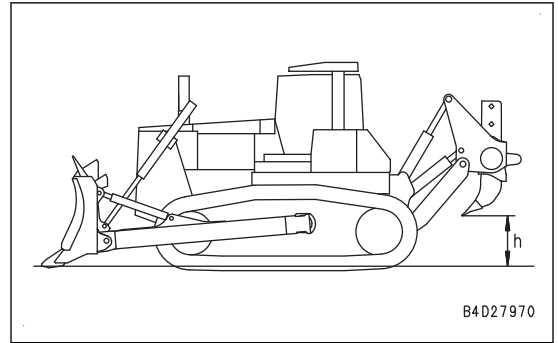
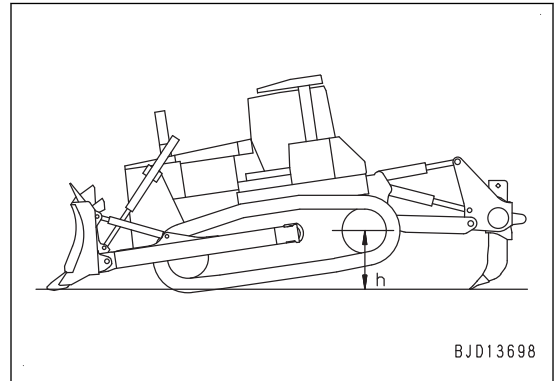

Fig. 10



## TEST EXHAUST GAS COLOR

### Testing tools for exhaust gas color

Symbol	Part No.	Part name	Q'ty	Remarks
A	799-201-9002	Handy smoke checker	1	Bosch index: 0 to 9
B	-	Commercially available Smoke meter	1	
	1	Commercially available Probe	1	

**⚠** Place the machine on a level ground, lower the work equipment completely to the ground, and stop the engine. Set the parking brake lever and work equipment lock lever to LOCK position.

**⚠** Be careful not to touch any hot parts when installing or removing the testing tools.

**⚠** Be careful not to burn yourself when regeneration of aftertreatment devices is performed. High temperature exhaust gas is spouted from the inspection port. "Regeneration Disable" operation must be performed with machine monitor before testing. (For the detail of "Regeneration Disable" operation, see Operation and Maintenance Manual.)

Check this item under the following conditions.

Engine coolant temperature: 60 to 100 °C

For testing the exhaust gas color to perform troubleshooting, refer to this section.

If compressed air or electric power as power source is not available in the field, use handy smoke checker A. When recording official data, etc., use smoke meter B.

### METHOD FOR TESTING EXHAUST GAS COLOR BY HANDY SMOKE CHECKER

1. Open the cover (1).

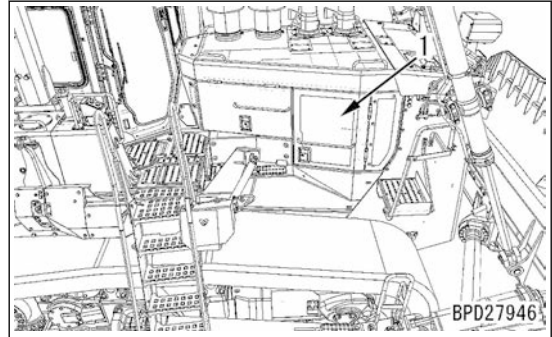

2. Remove the cover (2).

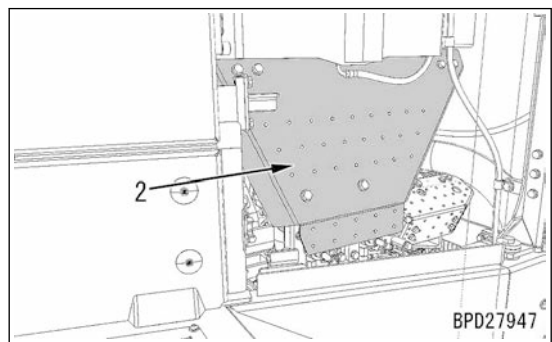

## HANDLE CYLINDER CUT-OUT MODE OPERATION

The cylinder cutout mode operation means to run the engine with the fuel injectors of one or more cylinders disabled electrically to reduce the number of active cylinders. The purposes and effects of cylinder cutout mode operation are as follows.

- Cylinder cutout mode operation is used to find out a cylinder which does not output power normally (or, combustion in it is abnormal).
- If the engine speed and output do not change from the normal operation (all-cylinder operation) when a cylinder is cutout with the cylinder cutout mode operation, that cylinder has a failure. The possible failures are as follows.
  - Compression gas leakage from cylinder head gasket area
  - Defective injection
  - Defective piston, piston ring or cylinder liner
  - Defective valve mechanism (valve operating system)
  - Defective electrical system
- Common rail fuel injection system individually controls the injector of each cylinder electronically , so the cylinder cutout test can be performed easily by the simple operations of the switches compared with the mechanical fuel injection system. So, the defective cylinder can be found out easily.

## ADJUST TRANSMISSION OUTPUT SHAFT SPEED SENSOR

**▲** Place the machine on a level ground, lower the work equipment completely to the ground, and stop the engine. Set the parking brake lever and work equipment lock lever to LOCK position.

For adjusting of transmission output shaft speed sensor to perform troubleshooting, or etc., refer to this section.

### METHOD FOR ADJUSTING TRANSMISSION OUTPUT SHAFT SPEED SENSOR

1. Remove the cover (5) at the bottom of the fuel tank.

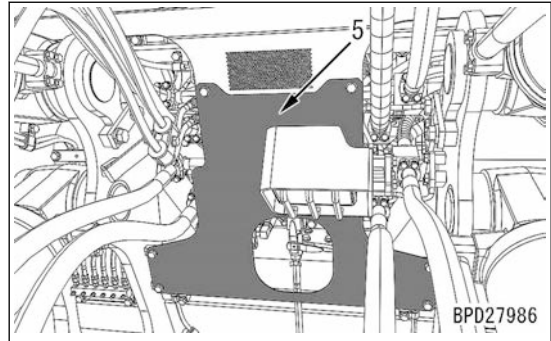

2. Remove the transmission output shaft speed sensor (1) and check the sensor end is free from iron dust or flaw, and then install it.

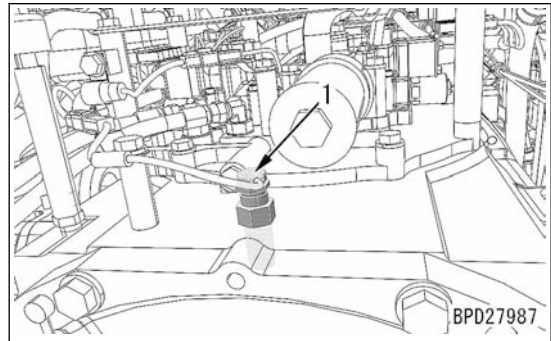

3. Screw the transmission output shaft speed sensor (1) until its end touches the tooth tip of the bevel gear (2).

 Threaded portion:  
Liquid gasket (LG-5)

4. Return the transmission output shaft speed sensor (1) by 1/2 to 1 turn.

#### REMARK

At this time, the clearance (a) between the transmission output shaft speed sensor (1) and the tooth tip of bevel gear (2) is 0.75 to 1.5 mm.

5. While fixing the transmission output shaft speed sensor (1), tighten the nut (3).

 Nut:  
49.0 to 68.6 Nm {5 to 7 kgfm}

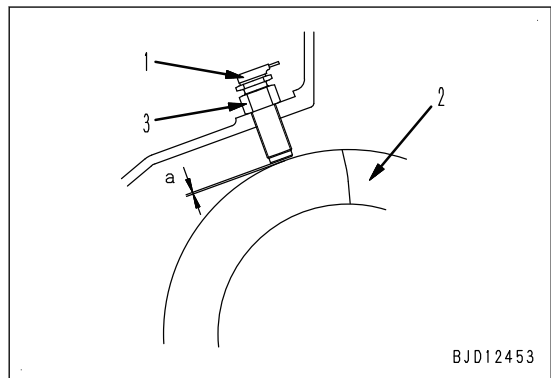

After finishing the adjustment, restore the machine.

### Method for checking transmission output shaft speed sensor after adjusting it

1. Turn the fuel control dial to MIN (Low idle) position, and start the engine.

- After 30 seconds, measure the leakage from the cylinder in 1 minute by using measuring cylinder A.

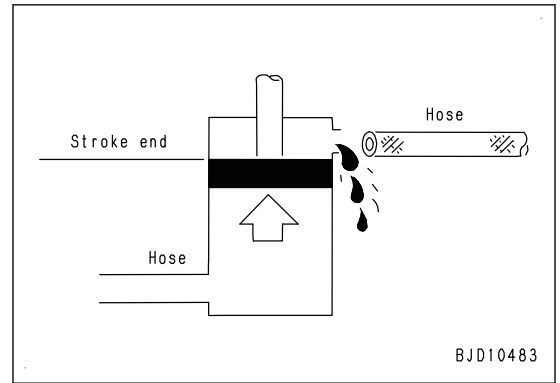

Remove the testing tools and restore the machine after the test is finished.

2. Check that striker (10) is not leaning from center (g) of latch (11).
3. Check if center (h) of striker (10) deviates from center (g) of latch (11).
  - Normal: Adjustment is unnecessary when shifting amount is 1 mm or less.
  - Abnormal: Adjustment is necessary when shifting amount is 1 mm and larger.

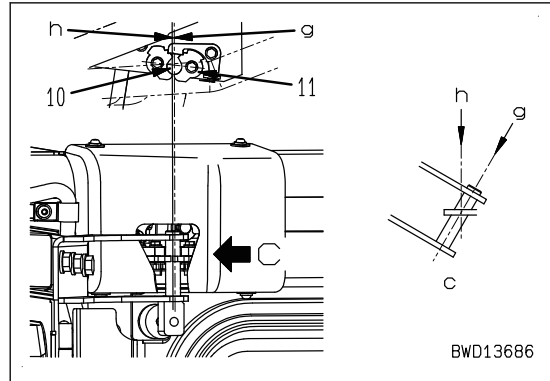

### Method for testing open lock (stopper rubber)

1. Move the unlocked door back and forth to check that there is no backlash.
  - Normal: Adjustment is unnecessary if there is no backlash.
  - Abnormal: Adjustment is necessary if there is backlash.
2. Check if the operating effort of the unlock lever is heavy.
  - Normal: Adjustment is unnecessary if the operating effort of the canceling lever is not heavy.
  - Abnormal: Adjustment is necessary if the operating effort of the canceling lever is heavy.

## METHOD FOR ADJUSTING OPERATOR'S CAB

### Adjustment of door lock (damper rubber)

Check the relationship between the cab and door (damper rubber portion) while the door is closed. If it is abnormal, adjust it.

1. Loosen the mounting bolts of damper rubber (6).

#### REMARK

You can remove and install the shim without removing the mounting bolt.

2. Increase or decrease shim (7) under damper rubber (6) and adjust the damper rubber (6) to the proper height.

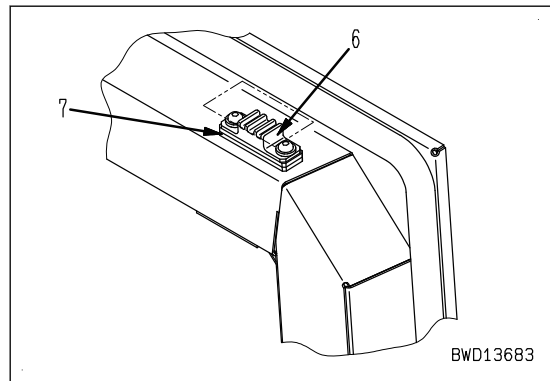

### Adjustment of door lock (latch and striker)

Check the relationship between the cab and door (latch and striker) while the door is closed. If it is abnormal, adjust it.

3. On “Electrical Sys Abnormality Record” screen, the following information is displayed.

- a: Occurrence order of abnormalities from latest one/ Total number of records
- b: Failure code
- c: Detail of failure
- d: Number of occurrences (displayable range: 0 to 65535 times)
- e: Service meter reading at the first occurrence
- f: Service meter reading at the last occurrence

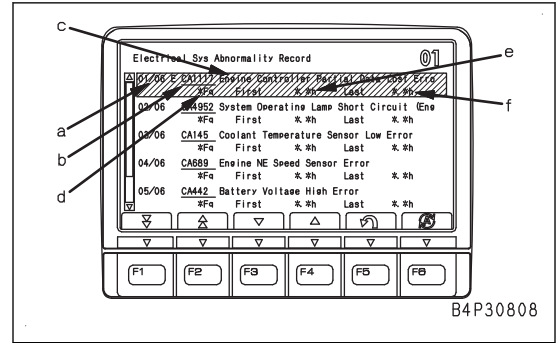

- F1: Moves the selection to next page (screen) (- When not being displayed on the screen, this function switch is enabled.)
- F1: Moves the selection to previous page (screen) (- When not being displayed on the screen, this function switch is enabled.)
- F3: Moves the selection downward.
- F4: Moves the selection upward.
- F5: Returns the screen to “Abnormality Record” screen
- F6: Display of contents of failure is scrolled to left again.

**REMARK**

- If no abnormality is recorded, “No Abnormality Record” is displayed.
- In Electrical system abnormality record, up to 20 of stored records are displayed. If the 21st record is stored, the oldest record will be deleted and the latest 20 records will be displayed.
- If the number of occurrence is 1 (first occurrence), the service meter reading at the first occurrence and that at the last occurrence are the same.
- If “E” is displayed on the left of a failure code, the abnormality is still occurring or it has not yet been normally restored.
- For all of the failure codes that the machine monitor can record, see TROUBLESHOOTING, “Failure code list”.
- If the characters in the failure are many, the character strings display is scrolled.

4. To delete a selected abnormality record, perform the following operation while “Electrical Sys Abnormality Record” screen is displayed.

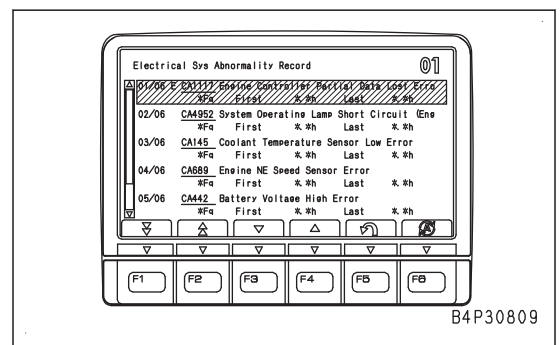

1) Switch operation (While pressing 4, press other switches in order): 4 + 1 → 2 → 3

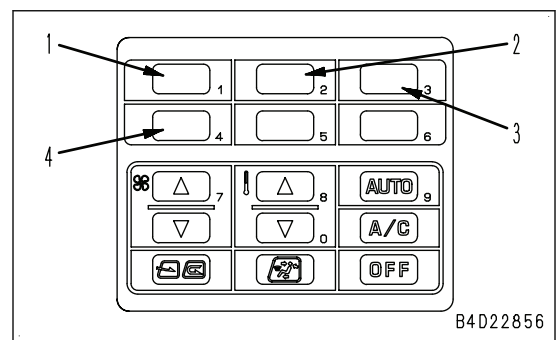

3. On “Adjustment” screen, perform adjustment of “Brake Pedal Potentio Initial Set” with function switches.

F3: Not used.

F4: Not used.

F5: Returns the screen to the adjustment item selection screen.

F6: Saves the compensation value.

- 1) Hold the brake pedal at the neutral position (not depressed).
- 2) Press F6, and check that warning buzzer sounds.

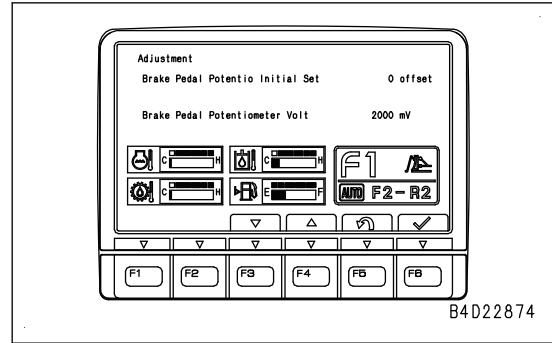

**REMARK**

- This adjustment does not change the displayed values other than the adjustment value.
- After the adjustment is completed, this saved compensation values are effective even while the starting switch is turned to OFF position.
- By Brake Pedal Potentio Initial Set, the braking performance is not adjusted.
- When performing the adjustment with “Adjustment ID: 0005 (Brake Pedal Potentio Initial Set)”, see “METHOD FOR PERFORMING WITH ADJUSTMENT ID: 0005 (BRAKE PEDAL POTENTIO INITIAL SET)”.

**METHOD FOR ADJUSTING WITH ADJUSTMENT MENU (SETTING PITCH ANGLE SENSOR STANDARD VALUE)**

By “Setting Pitch Angle Sensor Standard Value”, the power train controller recognizes the zero point of the pitch angle sensor, and corrects the installation error.

When the power train controller was replaced, or when pitch angle sensor was removed, installed, or replaced, be sure to perform this adjustment.

1. Select “Adjustment” on “Service Menu” screen.

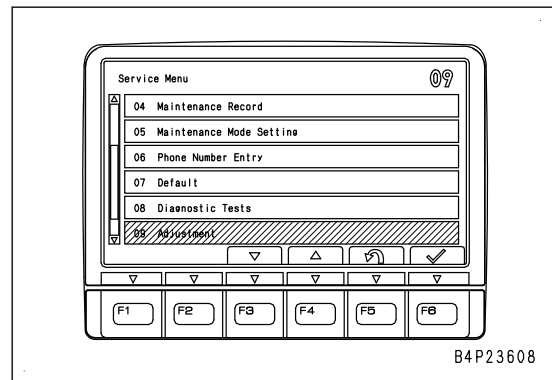

2. On “Adjustment” menu screen, select “Inclination Sensor Initial Set” with function switches or numeral input switches.

F3: Moves the selection downward.

F4: Moves the selection upward.

F5: Cancels the adjustment and returns the screen to “Service Menu” screen.

F6: Enters the selected adjustment items and moves the screen to the next “Adjustment” screen.

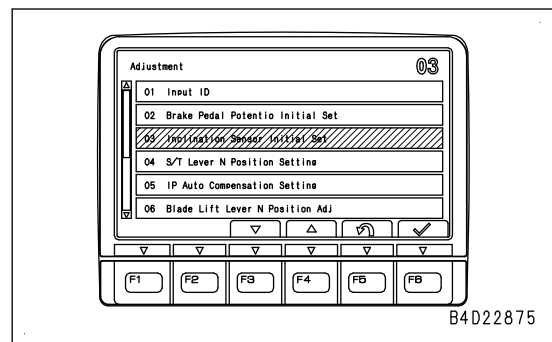

3. On "Input ID" screen, directly input Adjustment ID "5535" by using the numeral input switches.

F5: Returns the screen to "Adjustment" screen

F6: Enters the inputted Adjustment ID.

**REMARK**

- For Adjustment ID and adjustment items, see "ADJUSTMENT ITEMS TABLE".
- If the inputted Adjustment ID is incorrect, "Incorrect ID" will be displayed. "Input ID" screen does not proceed to the next screen. (Adjustment ID can be inputted again on this screen display.)

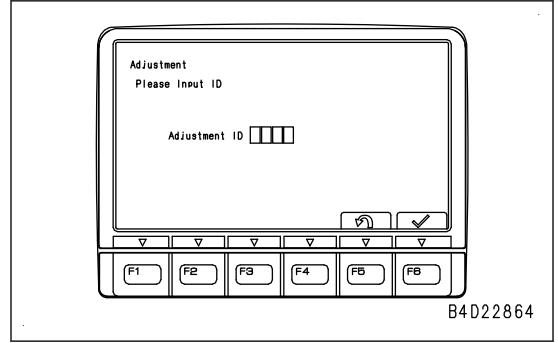

B4D22864

4. On "Both steering clutch release mode" screen, check the speed.

F3: Not use

F4: Not use

F5: Returns the screen to "Input ID" screen

F6: Not use

1) Press F3 or F4 to increase or decrease the adjustment value.

2) Press F6, and check that warning buzzer sounds.

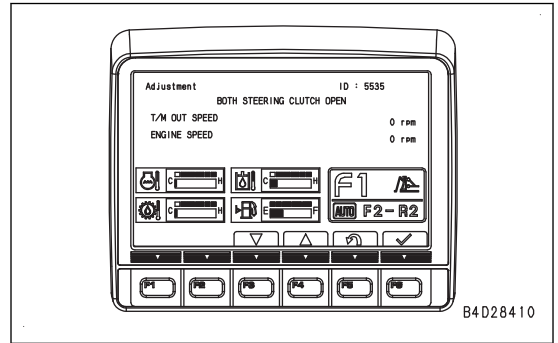

B4D28410

**REMARK**

- This function is enabled upon display of this adjustment code. Both steering clutches are now released at this time.
- The function will be disabled after this adjustment code is finished.

**METHOD FOR PERFORMING WITH ADJUSTMENT ID: 5537 (LEFT STEERING CLUTCH OIL PRESSURE OFFSET)**

This is a function that manually adjust the oil pressure of the left steering clutch.

The clutch oil pressure may be out of specified pressure due to wear of the clutch disc on some machines which have been operated for a long period of time. In such case, swing operation cannot be operated smoothly. This adjustment is for the oil pressure to be corrected so that the swing operation is performed smoothly.

Use this mode before starting operation as necessary.

1. Select "Adjustment" on "Service Menu" screen.

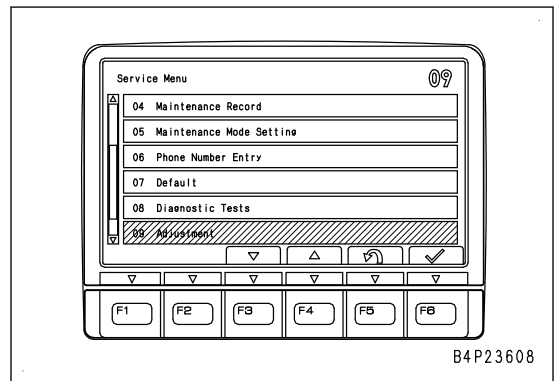

B4P23608

## KOMTRAX SETTINGS MENU

### METHOD FOR CONFIRMING KOMTRAX SETTINGS (TERMINAL STATUS)

On “KOMTRAX setting display” screen, select “Terminal Status” with the function switches or numeral input switches.

“Terminal Status” is used to check the setting condition of the KOMTRAX terminal.

1. Select “KOMTRAX Settings” on “Service Menu” screen.

**REMARK**

For selecting method, see “Operating method of service mode” in “SERVICE MODE”.

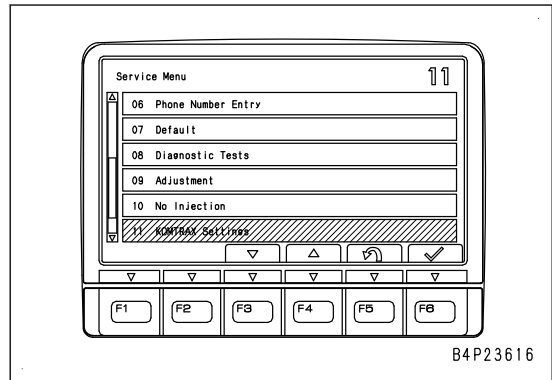

2. On “KOMTRAX Settings” screen, select “Terminal Status” with the function switches or numeral input switches.

**REMARK**

For selecting method, see “Operating method of service mode” in “SERVICE MODE”.

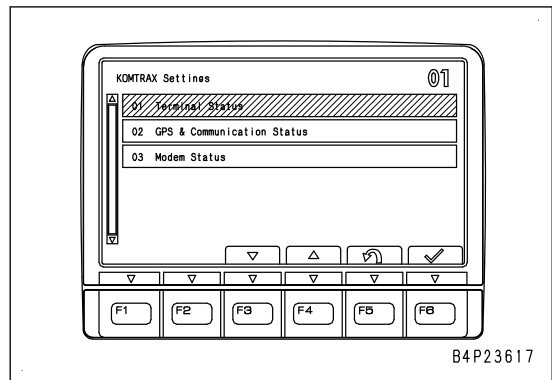

3. On “Terminal Status” screen, the following items are displayed.

Terminal Type: Model name of the KOMTRAX communication modem

KOMTRAX Communication Inspection: State of radio station establishment

GMT time: Greenwich Mean Time (add 9 hours to it for Japan time)

F5: Returns the screen to “KOMTRAX Settings” screen

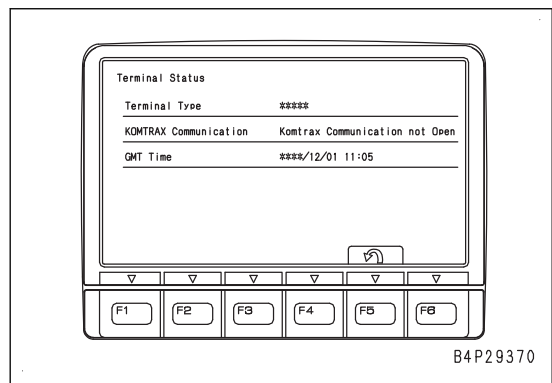

### METHOD FOR CONFIRMING KOMTRAX SETTINGS (GPS AND COMMUNICATION STATUS)

The setting and operating state of KOMTRAX can be checked by using “KOMTRAX Settings” screen.

“GPS & Communication State” is used to check the positioning and communication state of the KOMTRAX system.

# Pm CLINIC

## Pm CLINIC SERVICE

Machine model	Serial number	Service meter
<input type="checkbox"/> D375A-8		h
User name	Date of inspection	Inspector

Specifications			
Front attachment	Rear attachment	Shoe width	
<input type="checkbox"/> Semi-U dozer <input type="checkbox"/> Full-U dozer <input type="checkbox"/>	<input type="checkbox"/> Multi-shank ripper <input type="checkbox"/> Variable giant ripper <input type="checkbox"/> Counterweight (      kg) <input type="checkbox"/>	<input type="checkbox"/> 610 mm <input type="checkbox"/> 710 mm <input type="checkbox"/> 810 mm	<input type="checkbox"/> (      )

Operating condition			
Quarry, Mining	Construction	Type of soil	Details of work
<input type="checkbox"/> Coal <input type="checkbox"/> Gold <input type="checkbox"/> Limestone <input type="checkbox"/>	<input type="checkbox"/> Construction, civil engineering <input type="checkbox"/> Road <input type="checkbox"/> Tunnel <input type="checkbox"/>	<input type="checkbox"/> Rock <input type="checkbox"/> Gravel <input type="checkbox"/> Sand <input type="checkbox"/> Clay	<input type="checkbox"/> Dozing                      % <input type="checkbox"/> Side cutting                % <input type="checkbox"/> Ripping                      % <input type="checkbox"/> Travel                        %

Check of oil and coolant levels			
<input type="checkbox"/> Engine coolant <input type="checkbox"/> Engine oil level <input type="checkbox"/> Hydraulic oil level	When necessary <input type="checkbox"/> Damper case oil level <input type="checkbox"/> Power train oil level	<input type="checkbox"/> Final drive oil level <input type="checkbox"/>	
Outside air temperature		Altitude	
°C		m	

Operator's comment			

Result of visual inspection			

Mechanic system error record				Electric system error record			
AA10NX	Times/First time	h/Latest	h		Times/First time	h/Latest	h
AB00KE	Times/First time	h/Latest	h		Times/First time	h/Latest	h
B@BAZG	Times/First time	h/Latest	h		Times/First time	h/Latest	h
B@BCNS	Times/First time	h/Latest	h		Times/First time	h/Latest	h
B@BCZK	Times/First time	h/Latest	h		Times/First time	h/Latest	h
B@CENS	Times/First time	h/Latest	h		Times/First time	h/Latest	h
B@HANS	Times/First time	h/Latest	h		Times/First time	h/Latest	h
CA234	Times/First time	h/Latest	h		Times/First time	h/Latest	h

FAILURE CODE [CA3254]	40-515
FAILURE CODE [CA3255]	40-518
FAILURE CODE [CA3256]	40-521
FAILURE CODE [CA3311]	40-523
FAILURE CODE [CA3312]	40-525
FAILURE CODE [CA3313]	40-527
FAILURE CODE [CA3314]	40-528
FAILURE CODE [CA3315]	40-529
FAILURE CODE [CA3316]	40-532
FAILURE CODE [CA3317]	40-533
FAILURE CODE [CA3318]	40-534
FAILURE CODE [CA3319]	40-537
FAILURE CODE [CA3321]	40-538
FAILURE CODE [CA3322]	40-539
FAILURE CODE [CA3419]	40-542
FAILURE CODE [CA3421]	40-544
FAILURE CODE [CA4151]	40-546
FAILURE CODE [CA4158]	40-550
FAILURE CODE [CA4161]	40-551
FAILURE CODE [CA4162]	40-553
FAILURE CODE [CA4163]	40-555
FAILURE CODE [CA4259]	40-557
FAILURE CODE [CA4952]	40-560
FAILURE CODE [CA5383]	40-562
FAILURE CODE [CB115]	40-563
FAILURE CODE [CB187]	40-566
FAILURE CODE [CB227]	40-568
FAILURE CODE [CB238]	40-569
FAILURE CODE [CB239]	40-571
FAILURE CODE [CB271]	40-573
FAILURE CODE [CB272]	40-575
FAILURE CODE [CB273]	40-576
FAILURE CODE [CB274]	40-578
FAILURE CODE [CB343]	40-579
FAILURE CODE [CB352]	40-581
FAILURE CODE [CB386]	40-583
FAILURE CODE [CB441]	40-585
FAILURE CODE [CB442]	40-587
FAILURE CODE [CB689]	40-589
FAILURE CODE [CB697]	40-591
FAILURE CODE [CB698]	40-592
FAILURE CODE [CB731]	40-593
FAILURE CODE [CB778]	40-597
FAILURE CODE [CB1117]	40-599
FAILURE CODE [CB1257]	40-601
FAILURE CODE [CB1664]	40-602
FAILURE CODE [CB1691]	40-604
FAILURE CODE [CB1695]	40-607
FAILURE CODE [CB1696]	40-609
FAILURE CODE [CB1879]	40-611
FAILURE CODE [CB1881]	40-613
FAILURE CODE [CB1883]	40-615
FAILURE CODE [CB1921]	40-618
FAILURE CODE [CB1922]	40-620
FAILURE CODE [CB1923]	40-624
FAILURE CODE [CB1924]	40-626
FAILURE CODE [CB1925]	40-628
FAILURE CODE [CB1927]	40-630

## MAIN FILTER - CHECK

- ⚠ Immediately after the engine is stopped, its parts and oil are still very hot, and may cause burn injury. Accordingly, wait until all parts have cooled down before starting the work.
- ⚠ High pressure is generated inside the engine fuel piping system when the engine is running. Stop the engine and wait at least 30 seconds until the inner pressure is released and then replace the filter.
- ⚠ Keep fire away.

### NOTICE

- Komatsu genuine fuel filter cartridges adopt a special filter with high-efficiency filtering properties. Komatsu recommends Komatsu genuine parts when replacing.
  - The common rail fuel injection system used on this machine consists of more precise parts than those in the conventional injection pump and nozzles. If any cartridge other than a Komatsu genuine fuel filter cartridge is used, foreign materials may enter and problem may occur in the injection system. Do not use substitute parts.
  - During testing or maintenance of the fuel system, be sure that any foreign material does not enter the fuel system. If any dust or other material sticks to any part, wash the part thoroughly with clean fuel.
  - Prepare a container to receive oil.
  - Prepare a filter wrench.
1. Set supply valve (1) of the fuel tank to CLOSE (S) position.

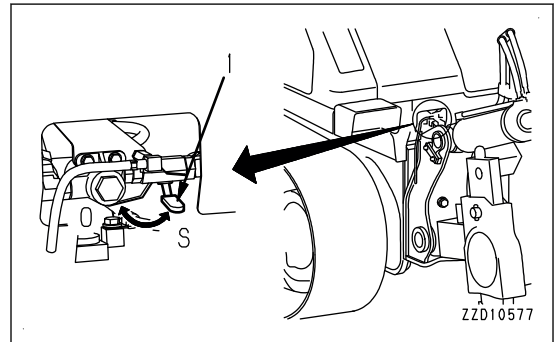

2. Open the side cover, and remove the mudguard cover.
3. Turn filter cartridge (2) counterclockwise by using the filter wrench, and remove it.
4. Clean the filter bracket and thinly apply oil to the packing surface of filter cartridge.

### REMARK

Do not fill the new filter cartridge with fuel.

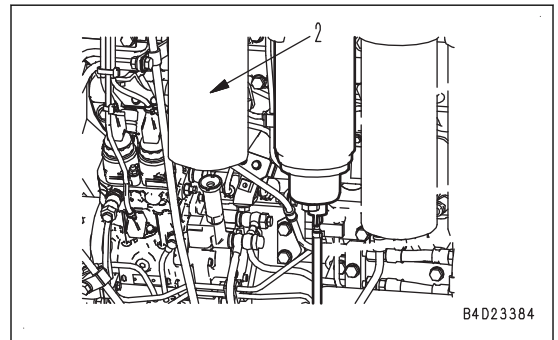



5. Remove cap A in the center, and then install it to the filter bracket
6. Install filter cartridge.

### REMARK

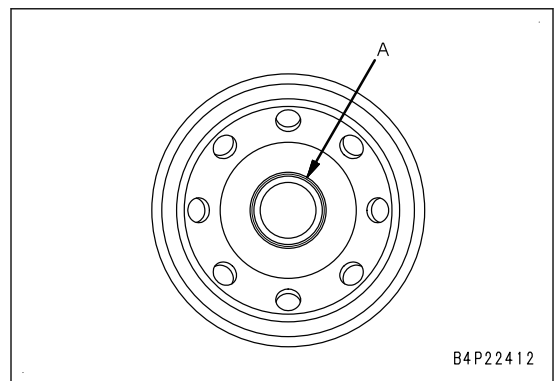
- When installing it, tighten it by 3/4 turns after the O-ring came in touch with the sealing surface of filter bracket.
- If the filter cartridge is fastened too much, the O-ring will be damaged and this leads to leakage of fuel. If the filter cartridge is too loose, fuel will also leak from gaps of the packing. Therefore, be sure to observe the fastening angle.

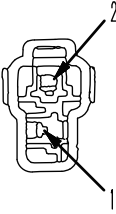
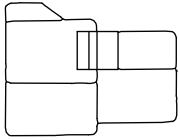
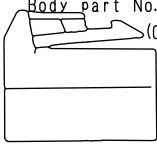
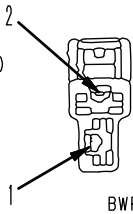
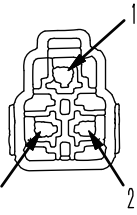
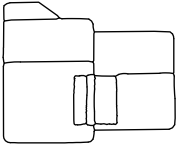

Connector No.	Connector type	Number of pins	Location	Address
B8L	Terminal	1	Breaker 30A	A-8
B8S	Terminal	1	Breaker 30A	A-8
B60L	Terminal	1	Breaker 60A	L-2
B60S	Terminal	1	Breaker 60A	L-2
B105L	Terminal	1	Breaker 105A	L-2
B105S	Terminal	1	Breaker 105A	L-2
BATB	Terminal	1	Battery	I-3
BATR	Terminal	1	Battery	J-3
BCD	DT	2	Diode	O-9
BCD3	DT	2	Diode	N-9
BEML	Terminal	1	Breaker 30A	A-7
BEMS	Terminal	1	Breaker 30A	A-9
BH1L	Terminal	1	Breaker 105A	B-7
BH2S	Terminal	1	Breaker 105A	A-9
BI1	Terminal	1	Battery isolator	B-9
BI2	Terminal	1	Battery isolator	C-9
BI3	Terminal	1	Battery isolator	B-9
BI4	Terminal	1	Battery isolator	A-9
BKAL	DT	2	Backup alarm	J-7
BKSW	DT	3	Brake pedal switch	O-2
BLR	-	5	Blue light relay (radio control)	BA-2
BNSW	DT	12	Intermediate connector (dual tilt knob)	T-9
BRBL	Terminal	1	Battery relay 1	A-7
BRBR	Terminal	1	Battery relay 2	K-1
BRC	Terminal	1	Battery relay 1	A-7
BRC	Terminal	1	Battery relay 2	L-1
BRE	Terminal	1	Battery relay 1	A-7
BRE	Terminal	1	Battery relay 2	K-1
BRK	DT	3	Brake pedal potentiometer	O-1
C1	Terminal	1	Power ladder unit	C-6
C2	DT	2	Power ladder unit	B-5
C30A	DRC	50	KOMTRAX Plus controller	O-6
C30B	DRC	50	KOMTRAX Plus controller	O-6
C31	-	8	KOMTRAX Plus controller	R-1
C32	-	8	KOMTRAX Plus controller	R-1
C33	AMP	8	Intermediate connector	O-6
C35	-	8	KOMTRAX Plus antenna	AC-8
CB1	-	2	Circuit breaker	T-1

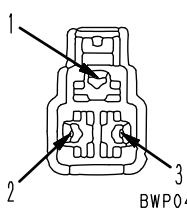
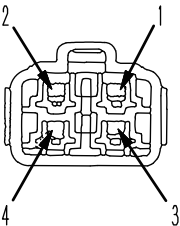
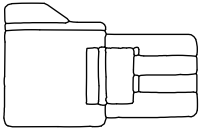
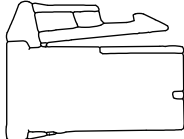
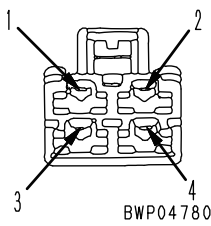
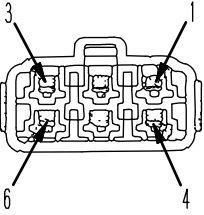
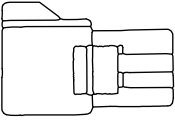
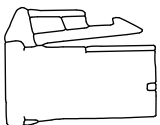
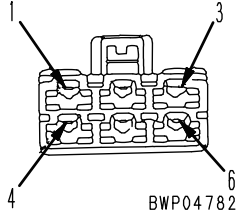
No. of pins	KES 1 (Automobile) connector		
	Male (female housing)	Female (male housing)	Testing connection use special tool Part No.
2	  <p>BWP04775</p>	<p>Body part No. : (Q'ty:5)</p>   <p>BWP04776</p>	—
	<p>Part No. : 08027-10210 (Natural color) 08027-10220 (Black)</p>		
3	  <p>BWP04777</p>	  <p>BWP04778</p>	—
	<p>Part No. : 08027-10310</p>		
4	  <p>BWP04779</p>	  <p>BWP04780</p>	—
	<p>Part No. : 08027-10410 (Natural color) 08027-10420 (Black)</p>		
6	  <p>BWP04781</p>	  <p>BWP04782</p>	—
	<p>Part No. : 08027-10610 (Natural color) 08027-10620 (Black)</p>		

B4D18402

Part No.	Part name	Number of pins	ID marking	T-adapter kit						Non-kit part
				799-A65-4600	799-902-9300					
799-601-4620	Adapter for controller (ENG-T4)	4	799-601-4620	•						
799-601-4630	Adapter for controller (ENG-T4)	2	799-601-4630	•						
799-601-4640	Adapter for controller (ENG-T4)	2	799-601-4640	•						
799-601-4651	Adapter for controller (ENG-T4)	24	799-601-4651	•						
799-601-4660	Adapter for controller (ENG-T4)	3	799-601-4660	•						
799-902-9310	Adapter for control box	19	799-902-9310		•					
799-902-9320	Adapter for IMU	10	799-902-9320		•					
799-902-9330	Adapter for MS cylinder	6	799-902-9330		•					
799T-601-4611	KDPF differential pressure sensor short socket adapter	4	799T-601-4611	•						
799T-601-4670	KDPF outlet pressure sensor short socket adapter	4	799T-601-4670	•						
799T-601-4680	KDPF dummy temperature sensor	4	799T-601-4680	•						

Failure code	Failure (Displayed on screen)	Applicable component	Action level	Category of history	Remarks
DXHWKY	Ripper Lift Raise EPC Solenoid Hot Short Circuit	WE	L03	Electrical system	
DXHXKA	Ripper Lift Lower EPC Solenoid Open Circuit	WE	L01	Electrical system	
DXHXKB	Ripper Lift Lower EPC Solenoid Short Circuit	WE	L01	Electrical system	
DXHXKY	Ripper Lift Lower EPC Solenoid Hot Short Circuit	WE	L03	Electrical system	
DXHYKA	Ripper Tilt In EPC Solenoid Open Circuit	WE	L01	Electrical system	
DXHYKB	Ripper Tilt In EPC Solenoid Short Circuit	WE	L01	Electrical system	
DXHYKY	Ripper Tilt In EPC Solenoid Hot Short Circuit	WE	L03	Electrical system	
DXHZKA	Ripper Tilt Back EPC Solenoid Open Circuit	WE	L01	Electrical system	
DXHZKB	Ripper Tilt Back EPC Solenoid Short Circuit	WE	L01	Electrical system	
DXHZKY	Ripper Tilt Back EPC Solenoid Hot Short Circuit	WE	L03	Electrical system	
DXJ4KA	W/E Lock Solenoid Open Circuit	PT	L03	Electrical system	
DXJ4KB	W/E Lock Solenoid Short Circuit	PT	L03	Electrical system	
DXJ8KA	Blade Tilt Left Bottom EPC Solenoid Open Circuit	WE	L01	Electrical system	
DXJ8KB	Blade Tilt Left Bottom EPC Solenoid Short Circuit	WE	L01	Electrical system	
DXJ8KY	Blade Tilt Left Bottom EPC Solenoid Hot Short Circuit	WE	L03	Electrical system	
DXJ9KA	Blade Tilt Left Head EPC Solenoid Open Circuit	WE	L01	Electrical system	
DXJ9KB	Blade Tilt Left Head EPC Solenoid Short Circuit	WE	L01	Electrical system	
DXJ9KY	Blade Tilt Left Head EPC Solenoid Hot Short Circuit	WE	L03	Electrical system	
DXJBKA	T/C Stator Clutch ECMV Solenoid Open Circuit	PT	L03	Electrical system	
DXJBKB	T/C Stator Clutch ECMV Solenoid Short Circuit	PT	L03	Electrical system	
DXJBKY	T/C Stator Clutch ECMV Solenoid Hot Short Circuit	PT	L03	Electrical system	
DY2HKA	Pre Lub. Motor Open Circuit	PT	L01	Electrical system	
F9A0KT	(Option cntlr) memory Error	OPT	L01	Electrical system	

Circuit diagram related to right clutch ECMV

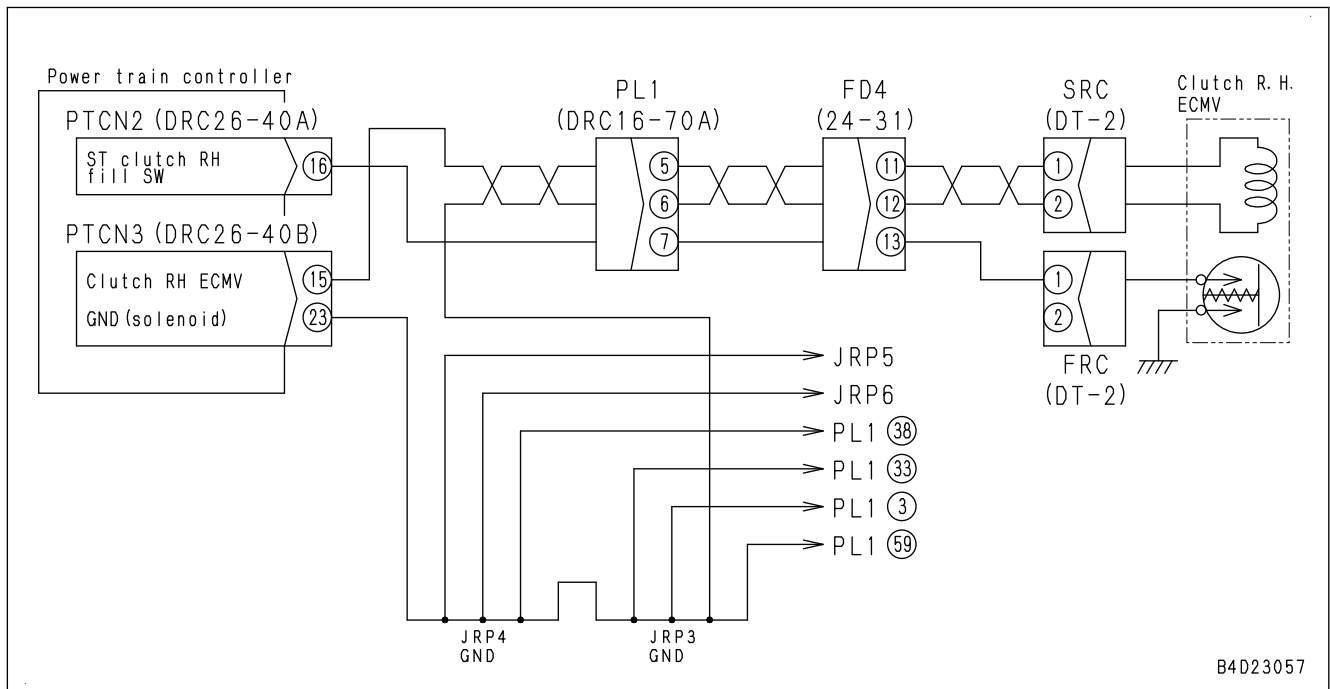

Circuit diagram related to radio control/on-board selector system

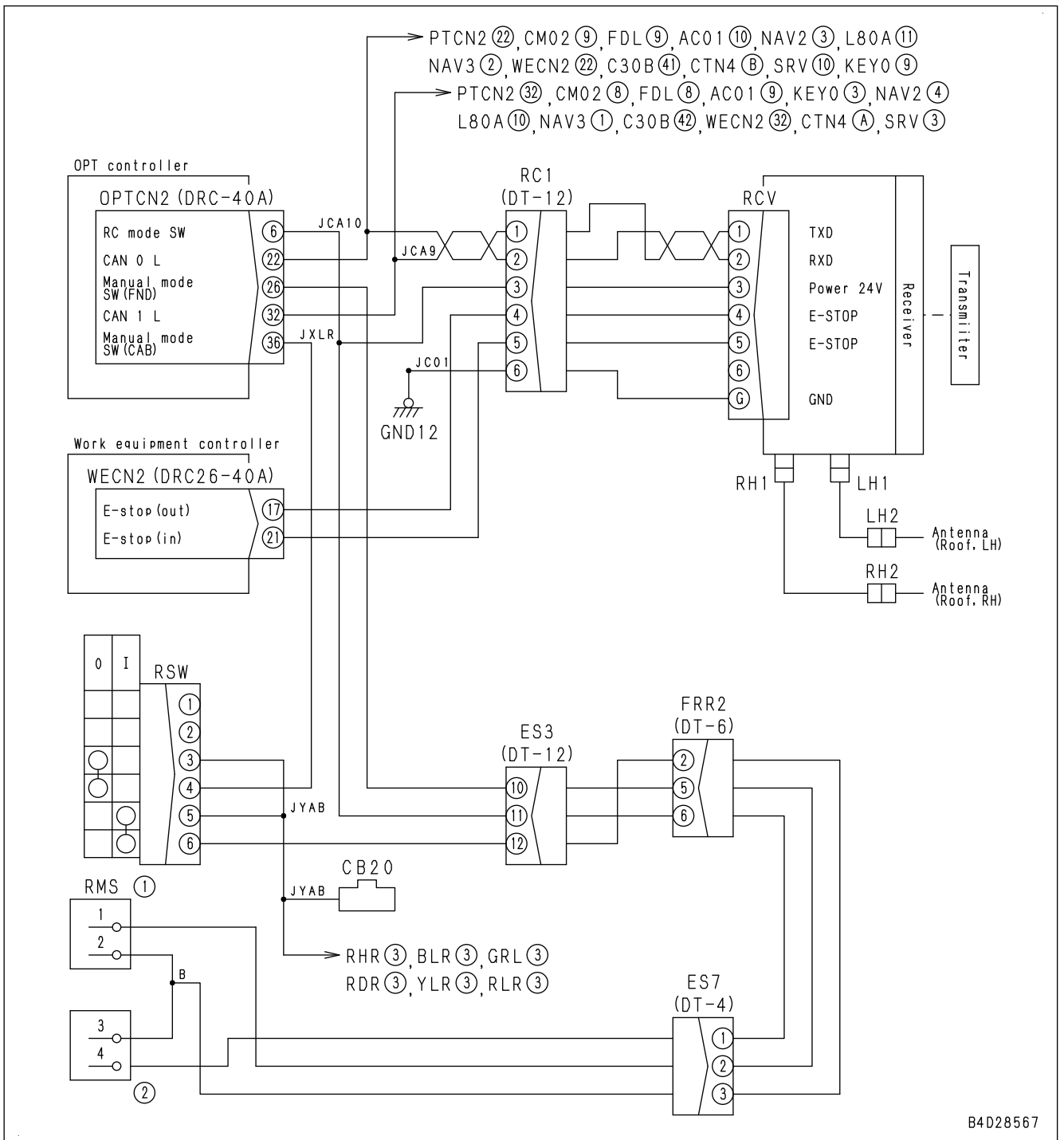

**FAILURE CODE [B@BAZK]**

Action level	Failure code	Failure	Eng Oil Level Low (Machine monitor system)
L01	B@BAZK		
Detail of failure	<ul style="list-style-type: none"> <li>When engine is stopped, it is detected that engine oil level sensor circuit is open (disconnected from ground) for 2 seconds or more. (This error, however, is not detected for 5 minutes after the engine stops.)</li> <li>The error detected while the engine is stopped remains active even after the engine is started.</li> </ul>		
Action of controller	<ul style="list-style-type: none"> <li>Makes engine oil level caution lamp light up.</li> <li>If cause of failure is eliminated, machine becomes normal by itself.</li> </ul>		
Phenomenon on machine	If machine is used as it is, engine may be seized.		
Related information	<ul style="list-style-type: none"> <li>Input state (ON/OFF) from engine oil level sensor can be checked with monitoring function. (Code: 04510)</li> <li>After completion of repair, check that the failure code is cleared by the following operation. Procedure: Turn the starting switch to ON position.</li> </ul>		

No.	Cause	Procedure, measuring location, criteria and remarks		
1	Low engine oil level	1. Since engine oil level low is detected, check engine oil level. 2. Perform TROUBLESHOOTING, "OIL PRESSURE DROPS". 3. When engine oil consumption is large, perform "ENGINE OIL CONSUMPTION IS EXCESSIVE" in S mode.		
2	Defective engine oil level sensor	1. Turn the starting switch to OFF position. 2. Disconnect the connector OLV, and connect the T-adapter to male side.		
		Resistance	Between OLV (male) (1) and ground	Max. 1 Ω
3	Open circuit in wiring harness	1. Turn the starting switch to OFF position. 2. Disconnect connectors CM02 and OLV, and connect the T-adapter to each female side.		
		Resistance	Between CM02 (female) (2) and OLV (female) (1)	Max. 1 Ω
4	Defective monitor controller	If no failure is found by above checks, monitor controller is defective. (Since this is an internal defect, troubleshooting cannot be performed).		

**Circuit diagram related to engine oil level**

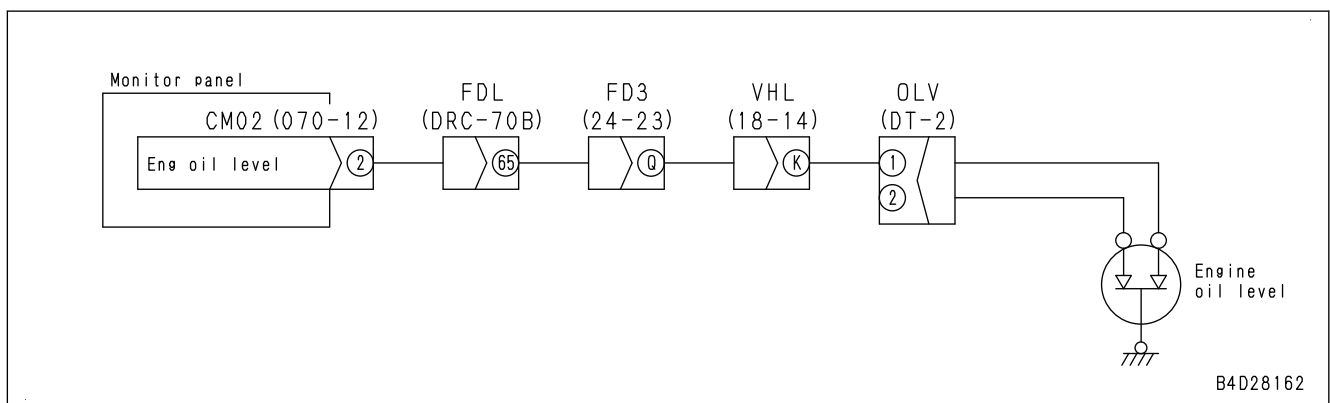

**FAILURE CODE [CA187]**

Action level	Failure code	Failure	Sensor 2 Supply Voltage Low Error (Engine controller system)
L03	CA187		
Detail of failure	Low voltage occurs in sensor 2 power supply (5 V) circuit.		
Action of controller	<ul style="list-style-type: none"> <li>• Ignores signals from EGR valve position sensor and VGT position sensor, and fixes values before detecting error for operation.</li> <li>• Ignores signal from dosing fuel pressure sensor, and fixes values before detecting error for operation.</li> <li>• Engine power deration.</li> </ul>		
Phenomenon on machine	Engine output is reduced.		
Related information	<ul style="list-style-type: none"> <li>• Connectors of electrical parts around engine may be defective due to heat and vibration. See descriptions of wiring harness and connectors in “Electrical equipment” in “CHECKS BEFORE TROUBLESHOOTING” of “RELATED INFORMATION ON TROUBLESHOOTING”, and check it.</li> <li>• Engine power deration is canceled by turning the starting switch to OFF position after this failure code is cleared. (This deration is not canceled by simply failure code being cleared.)</li> <li>• After completion of repair, check that the failure code is cleared by the following operation. Procedure: Turn the starting switch to ON position.</li> </ul>		

No.	Cause	Procedure, measuring location, criteria and remarks			
1	Defective sensor or wiring harness	1. Turn the starting switch to OFF position. 2. Disconnect following connectors one by one, and turn the starting switch to ON position each time. 3. After troubleshooting for one connector, return to step 1, and proceed to the next connector.  If this failure code is no longer displayed, disconnected sensor or engine wiring harness is defective.			
		<b>REMARK</b>			
		Many other failure codes appear at same time because of disconnected connector. Ignore failure codes other than this.			
		Connector	Dosing fuel pressure sensor		AFT1_PFU EL
			EGR valve lift sensor		SEGR
VGT position sensor			SVGT		
Engine wiring harness			ECM1 J1		
2	Defective engine controller	If no failure is found by above checks, engine controller is defective. (Since this is an internal defect, troubleshooting cannot be performed.)			

**FAILURE CODE [CA332]**

Action level	Failure code	Failure	Injector #4 (L#4) Open Circuit Error or Short Circuit Error (Engine controller system)
L03	CA332		
Detail of failure	Injector #4 circuit has open circuit or short circuit.		
Action of controller	None in particular		
Phenomenon on machine	<ul style="list-style-type: none"> <li>The engine power deration.</li> <li>Engine does not run stably.</li> </ul>		
Related information	<ul style="list-style-type: none"> <li>Connectors of electrical parts around engine may be defective due to heat and vibration. See descriptions of wiring harness and connectors in “Electrical equipment” in “CHECKS BEFORE TROUBLESHOOTING” of “RELATED INFORMATION ON TROUBLESHOOTING”, and check it.</li> <li>While engine is running normally, approximately 65 V of pulse voltage is supplied to injector (+) side. Because it is pulse voltage, it cannot be measured by using multimeter.</li> <li>If ground fault or hot short circuit is detected, failure codes [CA323], [CA325], and [CA332] are displayed at the same time.</li> <li>After completion of repair, check that the failure code is cleared by the following procedure. Procedure: Start the engine.</li> </ul>		

No.	Cause	Procedure, measuring location, criteria and remarks		
1	Defective injector #4	1. Turn the starting switch to OFF position. 2. Disconnect connector CN4, and connect T-adapter to male side.		
		Resistance	Between CN4 (male) (1) and (2)	0.4 to 1.1 Ω
			Between ground and CN4 (male) (1)	Min. 1 MΩ
2	Open circuit in wiring harness	1. Turn the starting switch to OFF position. 2. Disconnect connectors ECM1 J1 and CN4, and connect T-adapter to each female side.		
		Resistance	Between ECM1 J1 (female) (49) and CN4 (female) (1)	Max. 1 Ω
			Between ECM1 J1 (female) (73) and CN4 (female) (2)	Max. 1 Ω
3	Ground fault in wiring harness	1. Turn the starting switch to OFF position. 2. Disconnect connectors ECM1 J1 and CN4, and connect T-adapter to each female side.		
		Resistance	Between ground and ECM1 J1 (female) (49) or CN4 (female) (1)	Min. 1 MΩ
			Between ground and ECM1 J1 (female) (73) or CN4 (female) (2)	Min. 1 MΩ
4	Hot short circuit in wiring harness	1. Turn the starting switch to OFF position. 2. Insert T-adapter into connector ECM1 J1. 3. Turn the starting switch to ON position.		
		Voltage	Between ground and ECM1 J1 (49)	Max. 6 V

B. Testing with machine monitor (02 Abnormality Record, 01 Self-define Monitoring, 09 Cylinder Cutout Mode Operation)							Go od	No go od
3	Check of failure code							
4	Check of monitoring information							
	Code	Item to be displayed	Testing conditions	ISO unit	Standard value (reference value)	Measured value	Go od	No go od
	01002	Engine Speed	Low idle	r/min	750(±25)			
			High idle	r/min	1900(±25)			
			Torque converter stall	r/min	1530 (+50/-40)			
	31701	Throttle Position	Low idle	%	0			
			High idle	%	100			
	18600	Inject Fueling Command (amount)	Torque converter stall	mg/st	-		-	-
	36200	Rail Pressure Command	Torque converter stall	MPa	-			
	36400	Common Rail Pressure	Torque converter stall	MPa	-			
36500	Boost pressure	Torque converter stall	kPa	-		-	-	
04107	Coolant Temperature	Low idle	°C	-		-	-	
5	Check of Cylinder Cutout Mode Operation (engine speed)							
	Function	Cutout cylinder	Testing conditions	ISO unit	Standard value (reference value)	Measured value	Go od	No go od
	Set cutout to each cylinder.	No.1 cylinder	Low idle	r/min	-		-	-
		No.2 cylinder	Low idle	r/min	-		-	-
		No.3 cylinder	Low idle	r/min	-		-	-
		No.4 cylinder	Low idle	r/min	-		-	-
		No.5 cylinder	Low idle	r/min	-		-	-
No.6 cylinder		Low idle	r/min	-		-	-	
C. Check of fuel circuit pressure			Testing conditions	Unit	Standard value (reference value)	Measured value	Go od	No go od
6	Fuel pressure		High idle or under load equivalent to rated operation (at stall)	MPa {kg/cm <sup>2</sup> }	0.15 to 0.3 {1.5 to 3.0}			

**FAILURE CODE [CA1696]**

Action level	Failure code	Failure	Sensor 5 Supply Voltage Low Error (Engine controller system)
L03	CA1696		
Detail of failure	Low voltage error is detected in 5 V power supply of KDPF differential pressure sensor and KDPF outlet pressure sensor.		
Action of controller	<ul style="list-style-type: none"> <li>Sets KDPF outlet pressure sensor value to an estimated value and continues operation (may operate at 0 kPa {0 kgf/cm<sup>2</sup>}).</li> <li>Sets KDPF differential pressure sensor value to an estimated value and continues operation (may operate at 0 kPa {0 kgf/cm<sup>2</sup>}).</li> <li>Closes EGR valve.</li> <li>Engine power deration.</li> <li>Stops regeneration control.</li> </ul>		
Phenomenon on machine	Engine output is reduced.		
Related information	<ul style="list-style-type: none"> <li>Connectors of electrical parts around engine may be defective due to heat and vibration. See descriptions of wiring harness and connectors in “Electrical equipment” in “CHECKS BEFORE TROUBLESHOOTING” of “RELATED INFORMATION ON TROUBLESHOOTING”, and check it.</li> <li>Engine power deration is canceled by turning the starting switch to OFF position after this failure code is cleared. (This deration is not canceled by simply failure code being cleared.)</li> <li>After completion of repair, check that the failure code is cleared by the following operation. Procedure: Turn the starting switch to ON position.</li> </ul>		

No.	Cause	Procedure, measuring location, criteria and remarks		
1	Defective KDPF differential pressure (outlet pressure) sensor	1. Turn the starting switch to OFF position. 2. Disconnect the connector PDPF, and turn the starting switch to ON position.		
		<b>REMARK</b> Since connector is disconnected, other failure codes are also displayed. Ignore all of displayed failure codes other than this one.  If this failure code is not displayed, KDPF differential pressure (outlet pressure) sensor is defective.		
2	Ground fault in wiring harness	1. Turn the starting switch to OFF position. 2. Disconnect connectors ECM1 J2 and PDPF, and connect T-adapter to female side.		
		Resistance	Between ground and ECM1 J2 (female) (8) or PDPF (female) (4)	Min. 1 MΩ
3	Short circuit in wiring harness	1. Turn the starting switch to OFF position. 2. Disconnect connectors ECM1 J2 and PDPF, and connect T-adapter to female side of ECM1 J2.		
		Resistance	Between ECM1 J2 (female) (8) and each pin other than pin (8)	Min. 1 MΩ
4	Defective engine controller	If no failure is found by above checks, engine controller is defective. (Since this is an internal defect, troubleshooting cannot be performed.)		

- AFT1\_PFUEL: Dosing fuel pressure sensor -A connector
- AFT1\_SOV1: Dosing fuel solenoid valve 1-A (shut-off valve) connector
- AFT1\_SOV2: Dosing fuel solenoid valve 2-A (drain valve) connector
- AFT2\_PFUEL: Dosing fuel pressure sensor -B connector
- AFT2\_SOV1: Dosing fuel solenoid valve 1-B (shut-off valve) connector
- AFT2\_SOV2: Dosing fuel solenoid valve 2-B (drain valve) connector

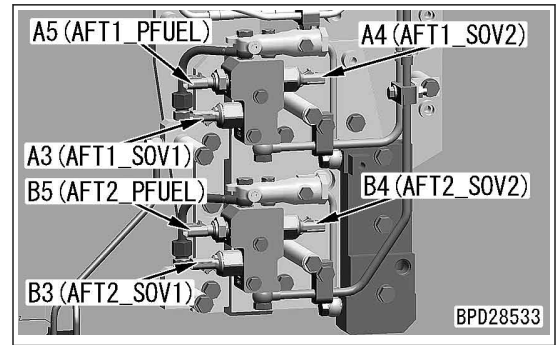

**Circuit diagram related to dosing fuel solenoid valve**

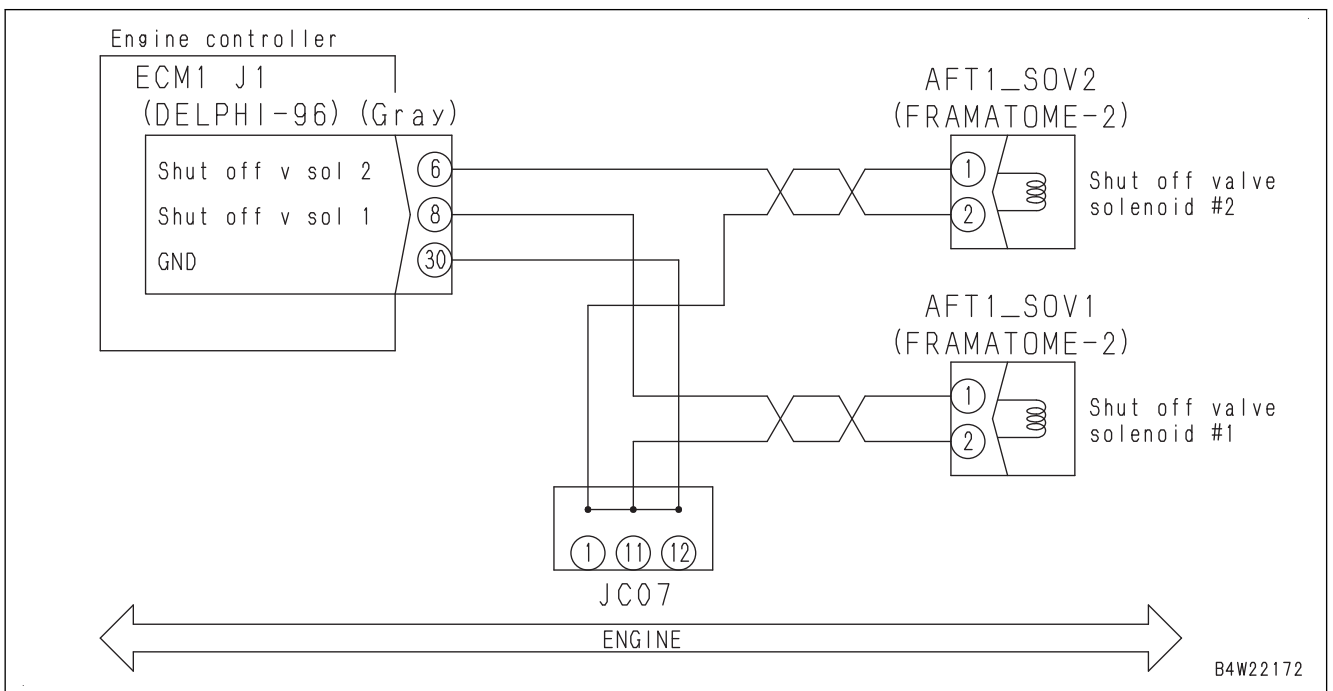

**FAILURE CODE [CA2382]**

Action level	Failure code	Failure	KVGT Position Sensor Low Error (Engine controller system)
L03	CA2382		
Detail of failure	Low voltage occurs in VGT position sensor signal circuit.		
Action of controller	<ul style="list-style-type: none"> <li>• Engine power deration.</li> <li>• Closes EGR valve and fully opens VGT.</li> <li>• Stops regeneration control.</li> </ul>		
Phenomenon on machine	Engine output is reduced.		
Related information	<ul style="list-style-type: none"> <li>• Connectors of electrical parts around engine may be defective due to heat and vibration. See descriptions of wiring harness and connectors in “Electrical equipment” in “CHECKS BEFORE TROUBLESHOOTING” of “RELATED INFORMATION ON TROUBLESHOOTING”, and check it.</li> <li>• If failure code [CA187] or [CA227] is also displayed, sensor power supply system may be defective. Perform troubleshooting for it first.</li> <li>• Signal voltage from VGT position sensor can be checked by monitoring. (Code: 48701)</li> <li>• Position (mm) detected by VGT position sensor can be checked by monitoring. (Code: 48700)</li> <li>• Engine power deration is canceled by turning the starting switch to OFF position after this failure code is cleared. (This deration is not canceled by simply failure code being cleared.)</li> <li>• After completion of repair, check that the failure code is cleared by the following operation. Procedure: Turn the starting switch to ON position.</li> </ul>		

No.	Cause	Procedure, measuring location, criteria and remarks	
1	Open circuit in wiring harness	1. Turn the starting switch to OFF position. 2. Disconnect connectors ECM1 J1 and SVGT, and connect T-adaptor to each female side.	
		Resistance	Between ECM1 J1 (female) (81) and SVGT (female) (A) Max. 1 Ω
			Between ECM1 J1 (female) (57) and SVGT (female) (B) Max. 1 Ω
			Between ECM1 J1 (female) (67) and SVGT (female) (C) Max. 1 Ω
2	Ground fault in wiring harness	1. Turn the starting switch to OFF position. 2. Disconnect connectors ECM1 J1 and SVGT, and connect T-adaptor to either female side.	
		Resistance	Between ground and ECM1 J1 (female) (67) or SVGT (female) (C) Min. 1 MΩ
3	Short circuit in wiring harness	1. Turn the starting switch to OFF position. 2. Disconnect connectors ECM1 J1 and SVGT, and connect T-adaptor to either female side.	
		Resistance	Between ECM1 J1 (female) (67) and (57) or between SVGT (female) (B) and (C) Min. 1 MΩ

No.	Cause	Procedure, measuring location, criteria and remarks		
3	Short circuit in wiring harness	1. Turn the starting switch to OFF position. 2. Disconnect connectors ECM1 J2 and PDPF, and connect T-adapter to female side of ECM1 J2.		
		Continuity	Between ECM1 J2 (female) (42) and each pin other than pin (42)	No continuity (no sound is heard)
4	Defective KDPF outlet pressure sensor	1. Turn the starting switch to OFF position. 2. Insert T-adapter into connector PDPF 3. Turn the starting switch to ON position.		
		Voltage	Between PDPF (female) (3) and (1)	0.5 to 4.5 V
5	Defective engine controller	1. Start the engine, and run it at low idle, and leave it for approximately 1 minute. 2. If other failure codes are displayed, perform troubleshooting for them.		
		If this failure code is still displayed and no failure is found by preceding checks, engine controller is defective. (In case of an internal defect, troubleshooting is impossible as an assembly. Replace whole assembly.)		

**Circuit diagram related to KDPF outlet pressure sensor**

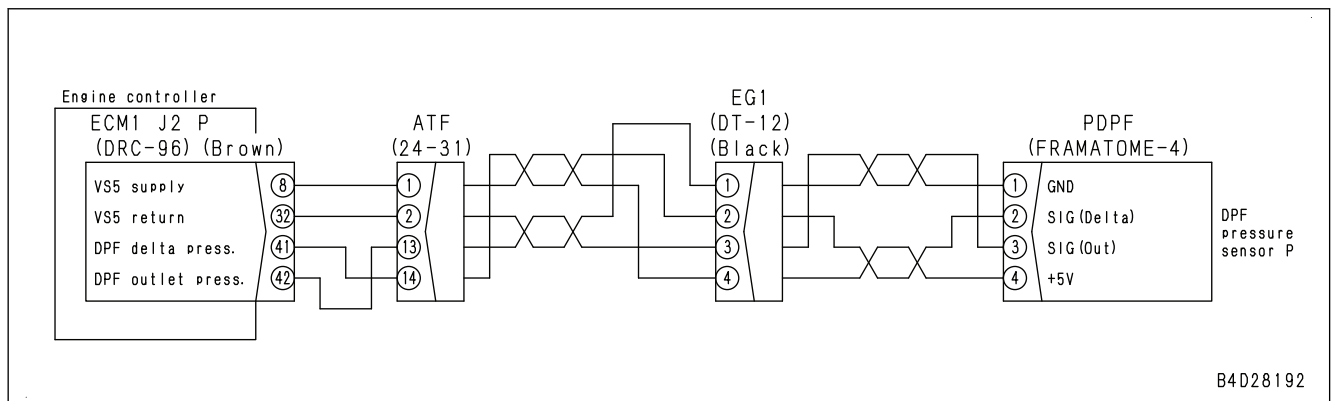

**FAILURE CODE [CA3318]**

Action level	Failure code	Failure	KDOC Outlet Temperature Sensor In Range Error (Engine controller system)
L03	CA3318		
Detail of failure	The difference between the temperature detected by KDOC outlet temperature sensor and the temperature detected by KDOC inlet temperature sensor differs from the expected value. (Signal voltage is within input range.)		
Action of controller	<ul style="list-style-type: none"> <li>• Uses KDOC inlet temperature for KDOC outlet temperature to run engine. (If failure is detected in KDOC inlet temperature sensor, too, controller takes it that KDOC outlet temperature is at default value (250 °C) and allows engine to run.)</li> <li>• Closes EGR valve.</li> <li>• Engine power deration.</li> <li>• Stops regeneration control.</li> <li>• Stops fuel dosing.</li> </ul>		
Phenomenon on machine	Engine output is reduced.		
Related information	<ul style="list-style-type: none"> <li>• Connectors of electrical parts around engine may be defective due to heat and vibration. See “RELATED INFORMATION ON TROUBLESHOOTING”, “CHECKS BEFORE TROUBLESHOOTING”, “Electrical equipment”, and check them according to the descriptions of wiring harness and connectors.</li> </ul> <p><b>⚠ KDPF and KDOC are heated to 500 °C or higher. Be careful not to get burn injury.</b></p> <ul style="list-style-type: none"> <li>• Temperature detected by KDOC inlet temperature sensor can be checked by monitoring. (Code: 47300)</li> <li>• Temperature detected by KDOC outlet temperature sensor can be checked by monitoring. (Code: 47400)</li> <li>• If failure code [CA1925] or [CA1963] is displayed, dosing fuel solenoid valve 1 may be defective. Perform troubleshooting for [CA1925] or [CA1963] first.</li> <li>• If failure code [CA3316] or [CA3317] is displayed, KDOC outlet temperature sensor may be defective. Perform troubleshooting for [CA3316] or [CA3317] first.</li> <li>• Temperature detected by KDOC inlet temperature sensor can be checked by monitoring. (Code: 47300)</li> <li>• Temperature detected by KDOC outlet temperature sensor can be checked by monitoring. (Code: 47400)</li> <li>• Engine power deration is canceled by turning the starting switch to OFF position after this failure code is cleared. (This deration is not canceled by simply failure code being cleared.)</li> <li>• To restart engine, wait until system operating lamp goes out after turning starting switch to OFF position, and then turn the starting switch to ON position.</li> </ul> <p><b>NOTICE</b></p> <ul style="list-style-type: none"> <li>• <b>This failure code requires “Loaded Diagnostics Operation To Confirm Failure Correction”. After investigating the cause of the problem and completing the repair, perform “Loaded Diagnostics Operation To Confirm Failure Correction” to make sure the failure code is cleared.</b></li> <li>• <b>This failure code can be cleared by performing “Engine Controller Active Fault Clear”. For details, see TESTING AND ADJUSTING, “ELECTRICAL SYSTEM”, “SET AND OPERATE MACHINE MONITOR”, “SERVICE MODE” and “METHOD FOR OPERATING TESTING MENU (ENGINE CONTROLLER ACTIVE FAULT CLEAR)” of “DIAGNOSTIC TESTS MENU”.</b></li> </ul>		

**Circuit diagram related to sensor 2 supply circuit**

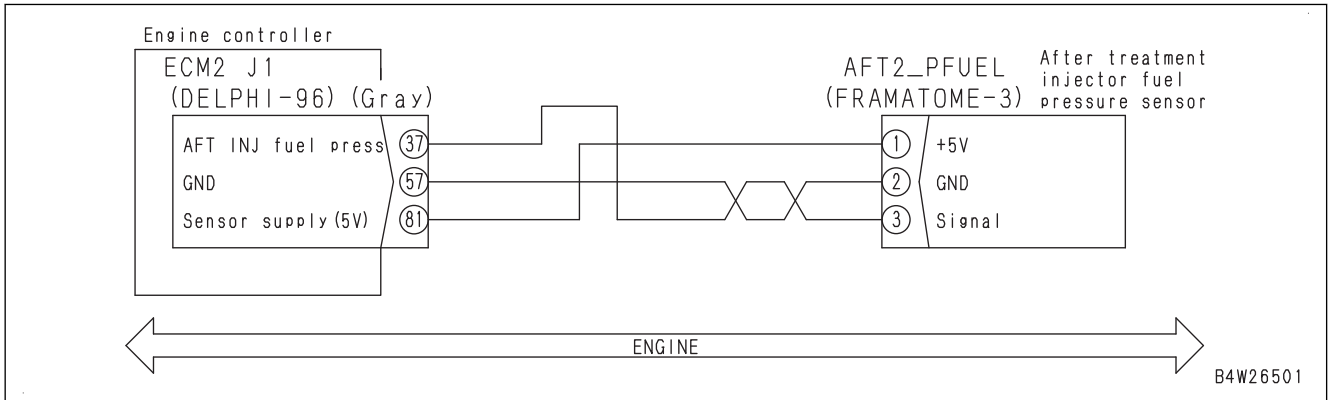

### CIRCUIT DIAGRAM (ENGINE CONTROLLER POWER SUPPLY)

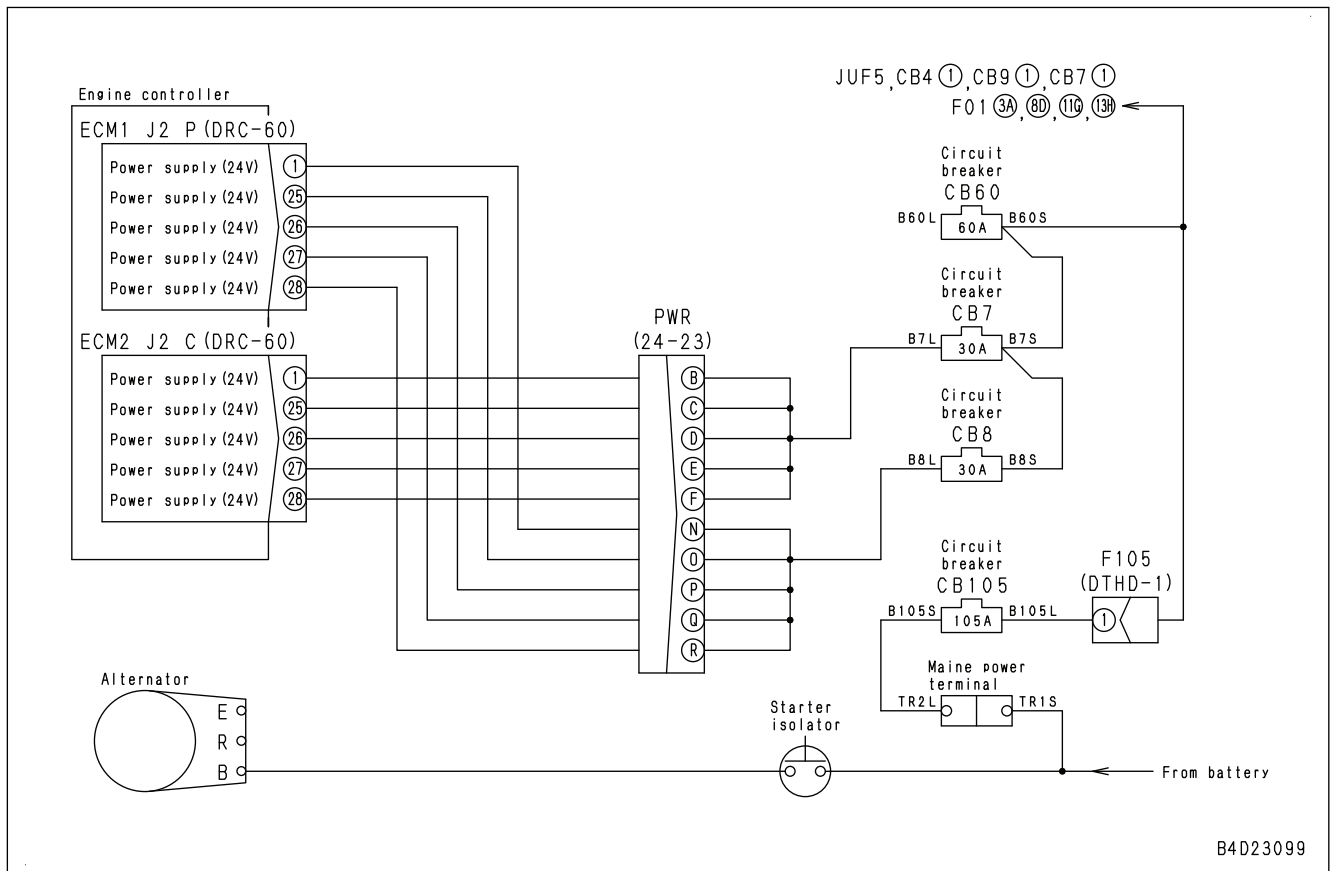

B4D23099

No.	Cause	Procedure, measuring location, criteria and remarks		
4	Defective dosing fuel pressure sensor	1. Turn the starting switch to OFF position. 2. Insert T-adapter into connector AFT2_PFUEL. 3. Turn the starting switch to ON position.		
		Voltage	Between AFT2_PFUEL (3) and (2)	0.5 to 4.5 V
5	Defective engine controller	If no failure is found by above checks, engine controller is defective. (Since this is an internal defect, troubleshooting cannot be performed.)		

**CIRCUIT DIAGRAM (DOSING FUEL PRESSURE SENSOR)**

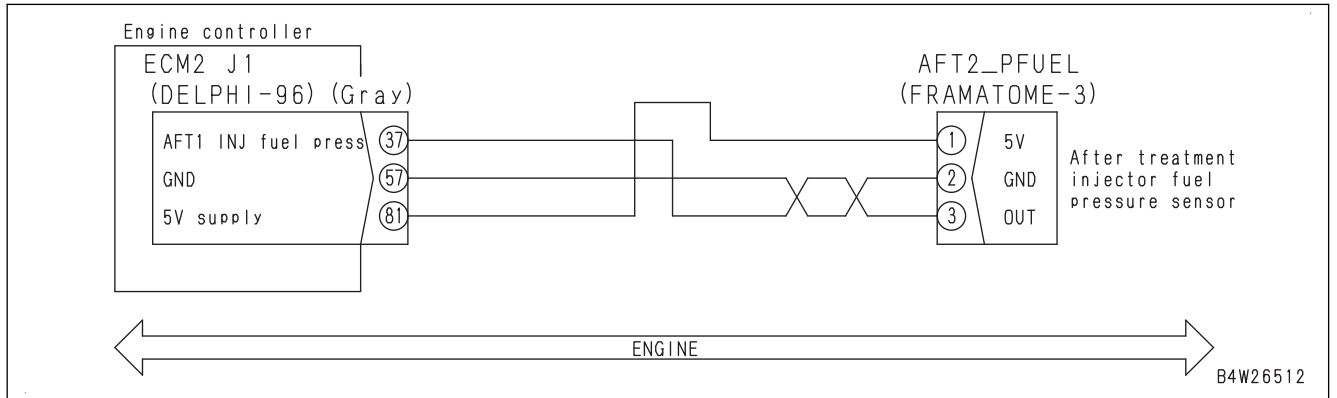

**FAILURE CODE [CB3133]**

Action level	Failure code	Failure	KDPF Outlet Pressure Sensor High Error_2 (Engine controller system)
L03	CB3133		
Detail of failure	High voltage is generated in signal circuit of KDPF outlet pressure sensor.		
Action of controller	<ul style="list-style-type: none"> <li>• Drives KDPF outlet pressure sensor at 0 kPa.</li> <li>• Closes EGR valve.</li> <li>• Engine power deration.</li> <li>• Stops regeneration control.</li> </ul>		
Phenomenon on machine	Engine output is reduced.		
Related information	<ul style="list-style-type: none"> <li>• Connectors of electrical parts around engine may be defective due to heat and vibration. See descriptions of wiring harness and connectors in “Electrical equipment” in “CHECKS BEFORE TROUBLESHOOTING” of “RELATED INFORMATION ON TROUBLESHOOTING”, and check it.</li> </ul> <p><b>⚠ KDPF is heated to 500 °C or higher. Be careful not to get burn injury.</b></p> <ul style="list-style-type: none"> <li>• If failure code [CB1695] or [CB1696] is displayed, sensor power supply system may be defective. Perform troubleshooting for [CB1695] or [CB1696] first.</li> <li>• Signal voltage from KDPF outlet pressure sensor can be checked by monitoring. (Code: 47003)</li> <li>• Differential pressure detected by KDPF outlet pressure sensor can be checked by monitoring. (Code: 47002)</li> <li>• Engine power deration is canceled by turning the starting switch to OFF position after this failure code is cleared. (This deration is not canceled by simply failure code being cleared.)</li> <li>• After completion of repair, check that the failure code is cleared by the following operation. Procedure: Turn the starting switch to ON position.</li> </ul>		

No.	Cause	Procedure, measuring location, criteria and remarks		
1	Defective KDPF outlet pressure sensor	<ol style="list-style-type: none"> <li>1. Turn the starting switch to OFF position.</li> <li>2. Disconnect connector PDPF_2.</li> <li>3. Turn the starting switch to ON position.</li> </ol>		
		If this failure code is changed to [CB3134], KDPF outlet pressure sensor is defective. <b>REMARK</b> Ignore other failure codes displayed.		
2	Open circuit in wiring harness	<ol style="list-style-type: none"> <li>1. Turn the starting switch to OFF position.</li> <li>2. Disconnect connectors ECM2 J2 and PDPF_2, and connect T-adapter to each female side.</li> </ol>		
		Resistance	Between ECM2 J2 (female) (32) and PDPF_2 (female) (1)	Max. 1 Ω

6. Perform the P mode torque converter stall operation continuously for 60 seconds with fuel control dial at MAX (high idle) position.

Torque converter stall operation

- 1) Use a manual gear shift mode in P mode.
- 2) On "Service Menu" screen of the machine monitor, select "Adjustment".
- 3) Enter 0530 "Stall mode" as an ID on the "Adjustment" screen.
- 4) Use a shift up (UP) switch on the PCCS lever to set preset mode display to [F3-R3].  
The preset mode display (on the lower right of the screen) can be set to [F3-R3] only when the stall mode is selected in "Adjustment" function.
- 5) With the brake pedal depressed securely and the parking brake lever in FREE position, set the direction of the PCCS lever to FORWARD position.

#### NOTICE

- **Make sure [F3] is displayed in a gear range display (on the lower right of the screen) before proceeding to the next step.**
  - **Hold the steering at NEUTRAL position.**
- 6) Depress the decelerator pedal and set the fuel control dial at High idle (MAX) position.
  - 7) Return the decelerator pedal slowly to stall the torque converter with the engine at high idle.  
**⚠ Keep the brake pedal depressed securely and place your right foot on the decelerator pedal for safety until the work is completed.**
  - 8) As soon as torque converter (power train) oil temperature (T/C (P/L) oil temperature) indicates 118 °C, reset the PCCS lever to NEUTRAL position.

#### NOTICE

- **Be careful that torque converter oil temperature does not overheat.**
  - **Temperature indicated at the top of the green range on the power train oil temperature is approximately 118 to 120 °C.**
7. Continuously repeat steps 6 for up to 25 minutes while being careful that torque converter oil does not overheat.
  8. Make sure that this failure code is cleared.

#### REMARK

- If this failure is cleared, the repair is completed.
- If this failure code is not cleared, return to the troubleshooting.

Circuit diagram related to engine starting relay

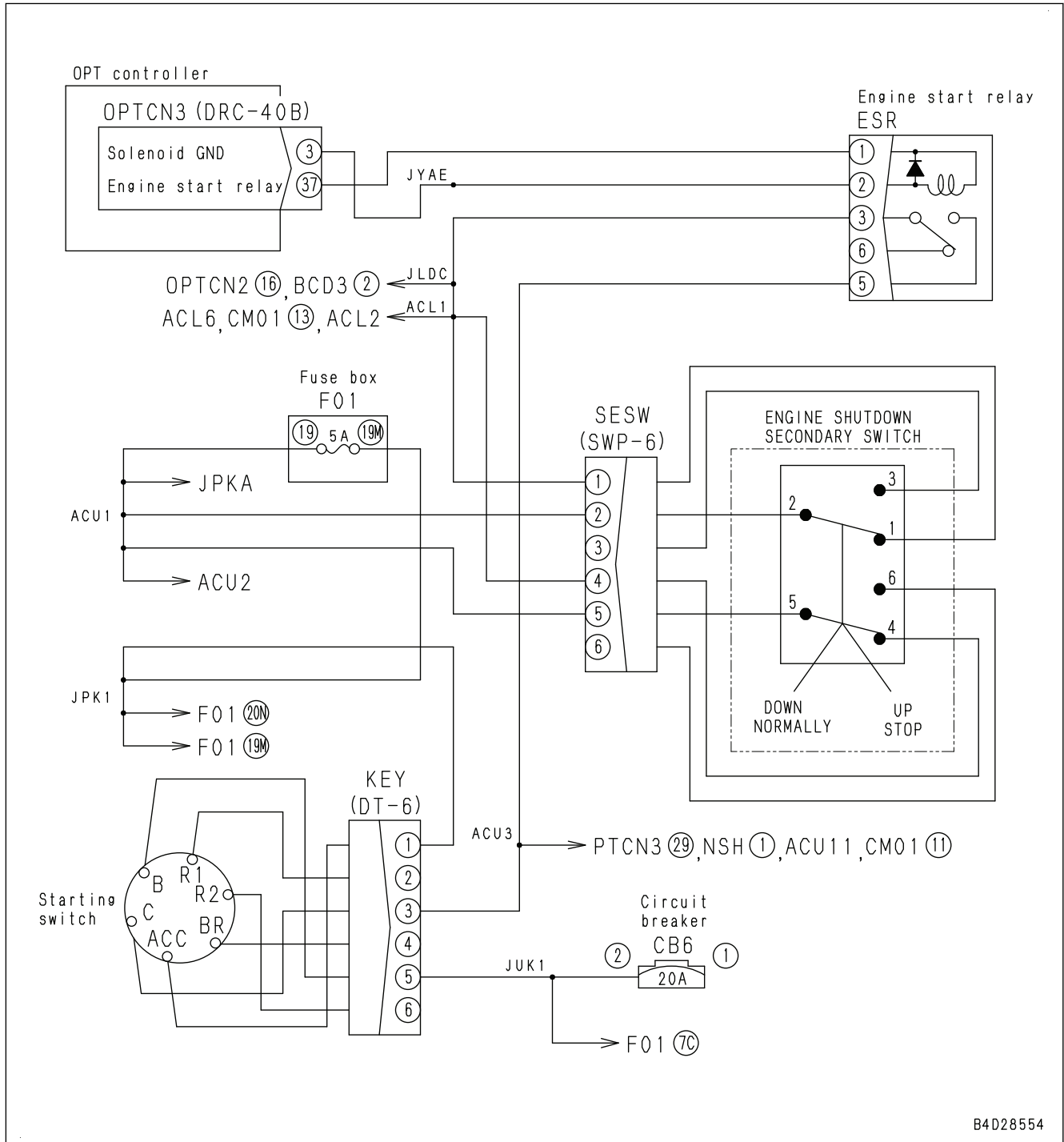

B4028554

### Circuit diagram related to green revolving lamp

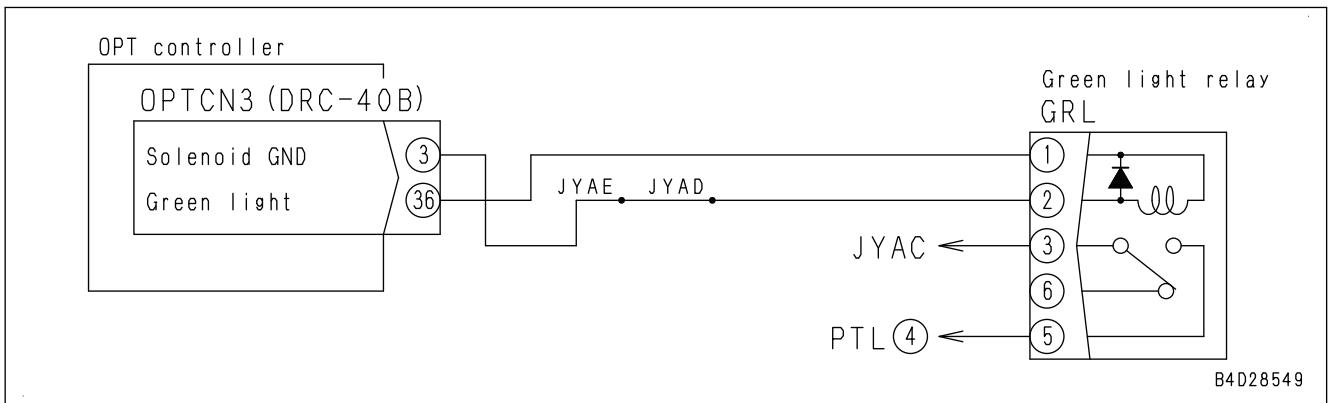

Circuit diagram related to system operating lamp

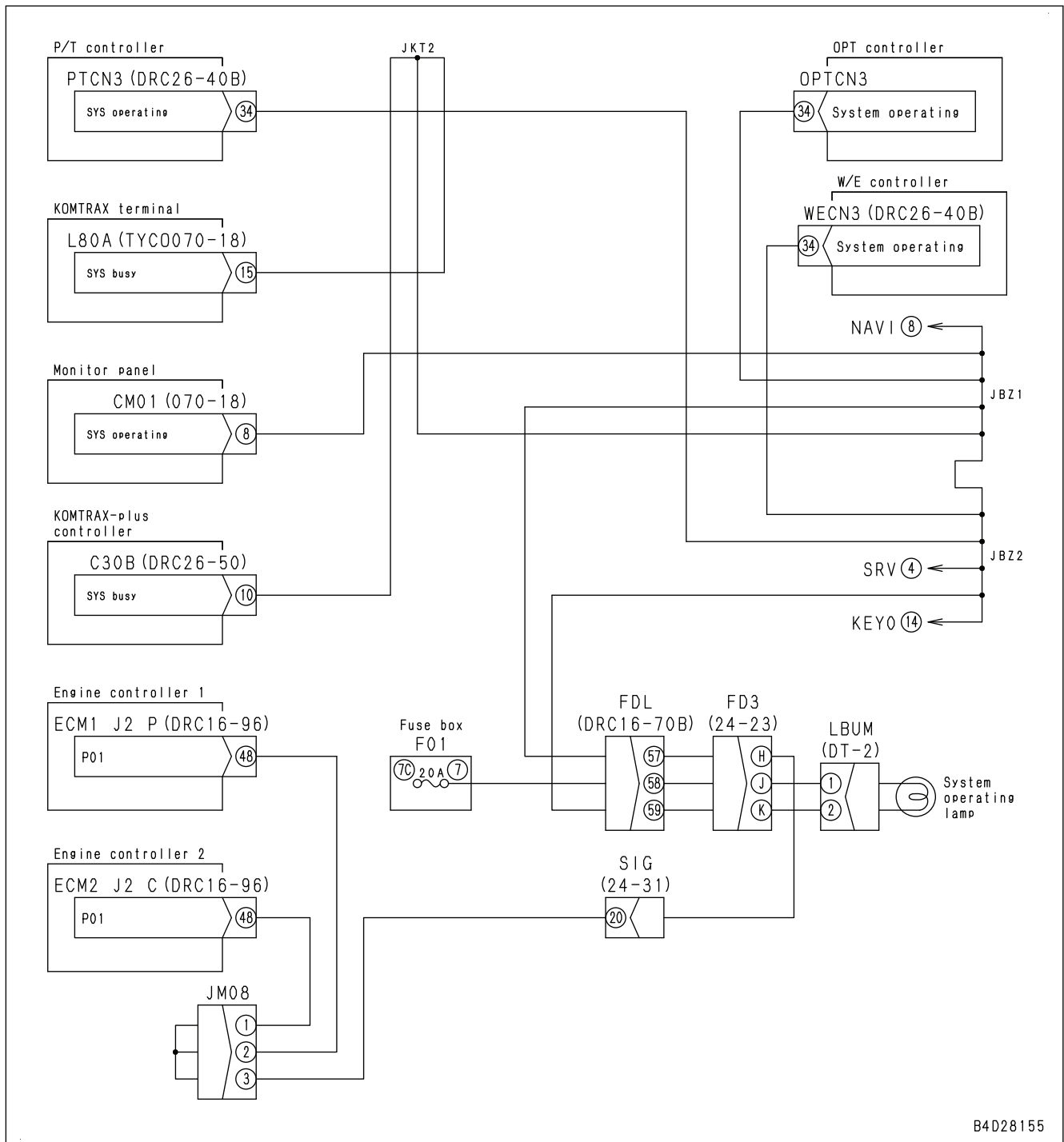

B4028155

CLICK HERE TO **DOWNLOAD** THE COMPLETE MANUAL

- Thank you very much for reading the preview of the manual.
- You can download the complete manual from: [www.heydownloads.com](http://www.heydownloads.com) by clicking the link below



- Please note: If there is no response to CLICKING the link, please download this PDF first and then click on it.

CLICK HERE TO **DOWNLOAD** THE COMPLETE MANUAL

**FAILURE CODE [DB97KK]**

Action level	Failure code	Failure	Work Equipment Controller 5V Sensor 1 Power Voltage Out of Range
L01	DB97KK		
Details of failure	<ul style="list-style-type: none"> <li>Voltage of 5 V power supply voltage circuit for work equipment controller sensor is below 4.5 V or above 5.5 V.</li> <li>Unusual current flows in 5 V power supply voltage circuit for work equipment controller sensor.</li> </ul>		
Action of controller	<ul style="list-style-type: none"> <li>Stops outputting of 5 V power supply circuit when abnormal current flows.</li> </ul>		
Phenomenon on machine	<ul style="list-style-type: none"> <li>Work equipment pump oil pressure is not monitored correctly (It does not affect machine behavior in particular).</li> </ul>		
Related information	<ul style="list-style-type: none"> <li>After repairing, check if the failure code is cleared by the following procedure. Procedure: Turn starting switch to ON position.</li> </ul>		

No.	Cause	Procedure, measuring location, criteria and remarks		
1	Defective hydraulic pump pressure sensor	<ol style="list-style-type: none"> <li>Turn the starting switch to OFF position.</li> <li>Disconnect the connector HHP.</li> <li>Turn the starting switch to ON position.</li> </ol> <p><b>REMARK</b> Since connector is disconnected, other failure codes are displayed. Ignore all of displayed failure codes other than this one.</p>		
		If this failure code is not displayed, hydraulic pump pressure sensor is defective.		
2	Ground fault in wiring harness	<ol style="list-style-type: none"> <li>Turn the starting switch to OFF position.</li> <li>Disconnect the connectors WE CN2 and HHP, and connect the T-adaptor to either female side.</li> <li>Disconnect the connectors, terminals, and fuses of all the devices which branch out from connectors WE CN2 (1).</li> </ol>		
		Resistance	Between ground and either WE CN2 (female) (1) or HHP (female) (B)	Min. 1 MΩ
3	Hot short circuit in wiring harness	<ol style="list-style-type: none"> <li>Turn the starting switch to OFF position.</li> <li>Disconnect the connector HHP, and connect the T-adaptor to female side.</li> <li>Turn the starting switch to ON position.</li> </ol>		
		Voltage	Between HHP (female) (B) and (A)	4.5 to 5.5 V
4	Defective work equipment controller	If no failure is found by preceding checks, work equipment controller is defective. (Since this is an internal defect, troubleshooting cannot be performed.)		

**FAILURE CODE [DBELKB]**

Action level	Failure code	Failure	System Operating Lamp Short Circuit (Power Train Controller) (Power train controller system)
-	DBELKB		
Detail of failure	Power train controller has detected a short circuit because voltage of output circuit does not become from low level while power train controller outputs current to system operating lamp.		
Action of controller	<ul style="list-style-type: none"> <li>• Turns driving the system operating lamp to OFF.</li> <li>• Even if cause of failure is eliminated, machine does not become normal until starting switch is turned to OFF position.</li> </ul>		
Phenomenon on machine	None in particular		
Related information	<ul style="list-style-type: none"> <li>• Do not turn the battery disconnect switch to OFF position while the system operating lamp is lit. If the battery disconnect switch is turned to OFF position, the memory data stored in the power train controller may be destroyed.</li> <li>• Although power train controller is not able to light up system operating lamp, no trouble will result unless battery disconnect switch is turned to OFF position.</li> <li>• When controller lights up system operating lamp, output circuit voltage is at low level.</li> <li>• After completion of repair, check that the failure code is cleared by the following procedure. Procedure: Turn the starting switch to ON position.</li> </ul>		

No.	Cause	Procedure, measuring location, criteria and remarks		
1	Hot short circuit in wiring harness	<ol style="list-style-type: none"> <li>1. Turn the starting switch to OFF position.</li> <li>2. Disconnect the connector LBUM, and connect the T-adapter to female side.</li> <li>3. Turn the starting switch to ON position.</li> </ol>		
		Voltage	Between LBUM (female) (2) and ground	Max. 1 V
2	Defective power train controller	If no failure is found by above checks, power train controller is defective. (Since this is an internal defect, troubleshooting cannot be performed.)		

## FAILURE CODE [DD14KB]

Action level	Failure code	Failure	Parking Brake Lever SW Short Circuit (Power train controller system)
L03	DD14KB		
Detail of failure	NO(Normally Open) and NC(Normally Closed) lines of parking brake lever switch circuit becomes 0 V (switch: ON) simultaneously.		
Action of controller	<ul style="list-style-type: none"> <li>Assumes that parking brake lever is in released position.</li> <li>Restricts operation of engine and transmission.</li> </ul>		
Phenomenon on machine	<ul style="list-style-type: none"> <li>Automatic gear shift function does not work.</li> <li>Once machine stops, engine speed is restricted to medium (half) speed.</li> <li>Once machine stops, selectable gear speeds are restricted to F1 and R1.</li> <li>Engine cannot start.</li> </ul>		
Related information	<ul style="list-style-type: none"> <li>NC line is for detecting operation, and NO line is for detecting errors.</li> <li>State of parking brake lever switch signal can be checked with monitoring function. (Code: 40905 P/T SW Input 1)</li> <li>After repairing, check if the failure code is cleared by the following procedure. Procedure: Turn starting switch to ON position and operate parking brake lever.</li> <li>When parking brake lever is in released position, parking brake lever switch is ON.</li> </ul>		

No.	Cause	Procedure, measuring location, criteria and remarks			
1	Defective parking brake lever switch	<ol style="list-style-type: none"> <li>Turn the starting switch to OFF position.</li> <li>Disconnect the connector PKSW, and connect the T-adapter to male side.</li> <li>Operate the parking brake lever to perform troubleshooting.</li> </ol>			
		Resistance	Between PKSW (male) (A) and (B)	Lever: LOCK	Min. 1 MΩ
				Lever: FREE	Max. 1 Ω
			Between PKSW (male) (A) and (C)	Lever: LOCK	Max. 1 Ω
	Lever: FREE		Min. 1 MΩ		
2	Hot short circuit in wiring harness	<ol style="list-style-type: none"> <li>Turn the starting switch to OFF position.</li> <li>Disconnect the connector PKSW, and connect the T-adapter to female side.</li> <li>Turn the starting switch to ON position.</li> </ol>			
		Voltage	Between ground and PKSW (female) (B)	7 to 11 V	
			Between PKSW (female) (C) and ground	7 to 11 V	
3	Defective power train controller	If no failure is found by above checks, power train controller is defective. (Since this is an internal defect, troubleshooting cannot be performed.)			

**FAILURE CODE [DDN7L4]**

Action level	Failure code	Failure	Blade Pitch Back SW Signal Mismatch (Work equipment controller system)
L01	DDN7L4		
Detail of failure	<ul style="list-style-type: none"> <li>Signals of 2 NO(Normally Open) circuits of blade pitch-back lever disagree with each other.</li> </ul>		
Action of controller	<ul style="list-style-type: none"> <li>Assumes that blade pitch back lever is in neutral.</li> </ul>		
Phenomenon on machine	<ul style="list-style-type: none"> <li>Blade pitch back control is disabled.</li> </ul>		
Related information	<ul style="list-style-type: none"> <li>State of blade pitch back lever signal can be checked with monitoring function. (Code: 70306 Blade knob switch input 2)</li> <li>After repairing, check if the failure code is cleared by the following procedure. Procedure: Turn starting switch to ON position and operate blade lever (in pitch back direction).</li> </ul>		

No.	Cause	Procedure, measuring location, criteria and remarks			
1	Defective blade pitch back lever	1. Turn the starting switch to OFF position. 2. Disconnect the connector BNSW, and connect the T-adapter to male side. 3. Operate the blade pitch lever (in pitch back direction) to perform troubleshooting.			
		<b>REMARK</b>			
		"Switch OFF": Release, "Switch ON": Press			
		Resistance	Between BNSW (male) (11) and (9)	FREE	Min. 1 MΩ
			Pitch BACK		Max. 1 Ω
	Between BNSW (male) (10) and (9)	FREE	Min. 1 MΩ		
	Pitch BACK		Max. 1 Ω		
2	Open circuit in wiring harness	1. Turn the starting switch to OFF position. 2. Disconnect connectors WECN1, WECN2 and BNSW, and connect the T-adapter to each female side.			
		Resistance	Between WECN2 (female) (12) and BNSW (female) (11)	Max. 1 Ω	
			Between WECN2 (female) (3) and BNSW (female) (10)	Max. 1 Ω	
			Between WECN1 (female) (4) and BNSW (female) (9)	Max. 1 Ω	
3	Ground fault in wiring harness	1. Turn the starting switch to OFF position. 2. Disconnect connectors WECN2 and BNSW, and connect the T-adapter to either female side.			
		Resistance	Between ground and either WECN2 (female) (3) or BNSW (female) (10)	Min. 1 MΩ	
			Between ground and either WECN2 (female) (12) or BNSW (female) (11)	Min. 1 MΩ	

Circuit diagram related to blade tilt lever potentiometer

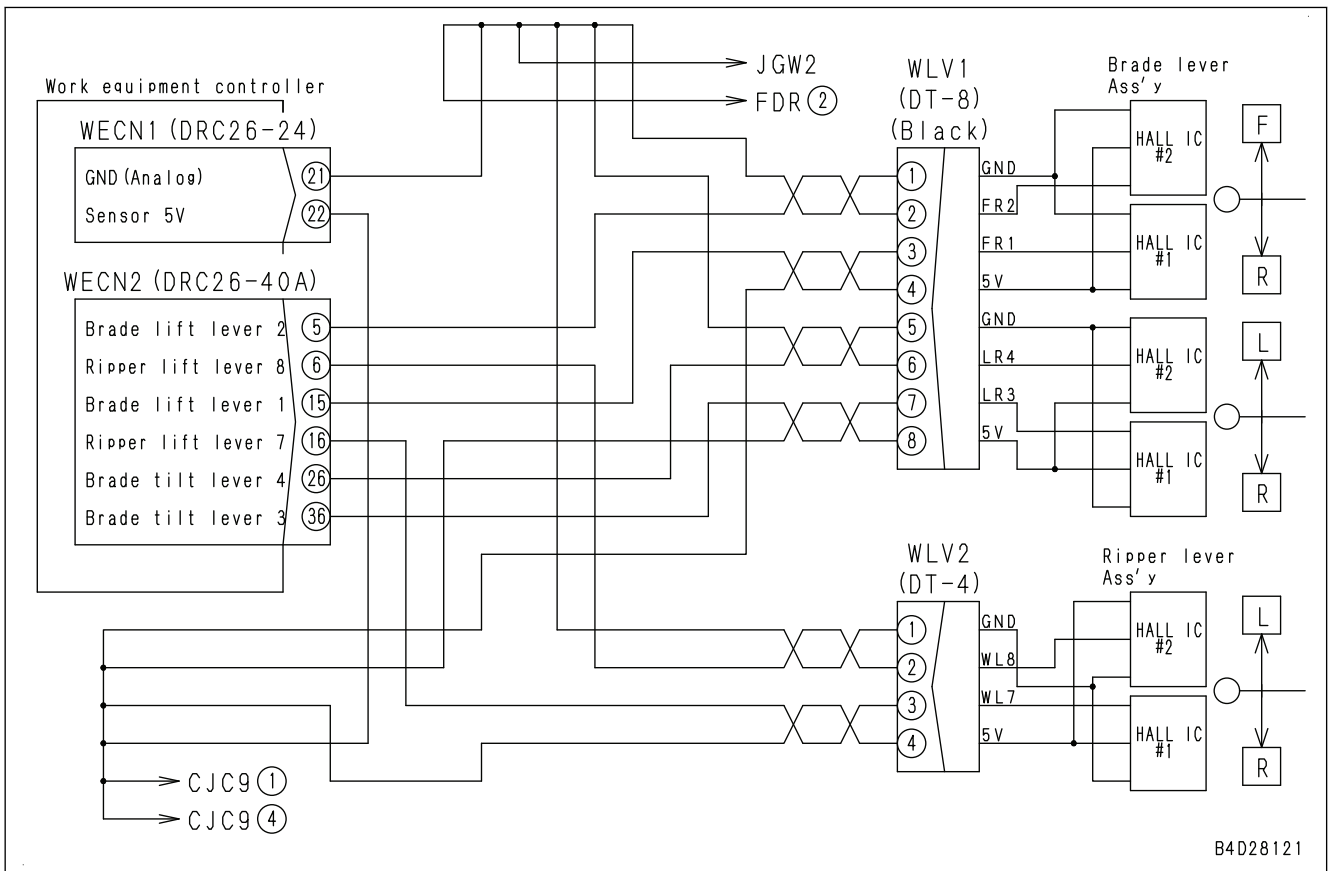

**FAILURE CODE [DHAAMA]**

Action level	Failure code	Failure	KDPF Differential Pressure Sensor Frozen (Engine controller system)
-	DHAAMA		
Detail of failure	Signal voltage from KDPF differential pressure sensor does not show a correct value when ambient temperature is low because of frozen KDPF differential pressure sensor. (Signal voltage is within "normal" or "operating" range.)		
Action of controller	<ul style="list-style-type: none"> <li>• Normal operation</li> </ul>		
Phenomenon on machine	None in particular.		
Related information	<p><b>⚠ KDPF and KDOC are heated to 500 °C or higher. Be careful not to get burn injury.</b></p> <ul style="list-style-type: none"> <li>• If failure code [CA1883] is displayed, or if it is logged in the abnormality record, perform troubleshooting for failure code [CA1883] first.</li> <li>• The cause of this failure code is solved after freeze is solved. Troubleshooting is not necessary.</li> <li>• If the ambient temperature is not at freezing point of the sensor when this failure code is displayed on abnormality record, identify the cause according to the following procedures.</li> <li>• KDPF differential pressure sensor and KDPF outlet pressure sensor are provided as a unit.</li> <li>• Signal voltage from KDPF differential pressure sensor can be checked with monitoring function. (Code: 47101 (V))</li> <li>• Differential pressure detected by KDPF differential pressure sensor can be checked with monitoring function. (Code: 47100 (kPa))</li> <li>• Temperature detected by KDOC inlet temperature sensor can be checked with monitoring function. (Code: 47300 (°C))</li> <li>• Temperature detected by KDOC outlet temperature sensor can be checked with monitoring function. (Code: 47400 (°C))</li> <li>• Temperature detected by KDPF outlet temperature sensor can be checked with monitoring function. (Code: 47200 (°C))</li> <li>• The KDOC inlet temperature sensor, KDOC outlet temperature sensor, and KDPF outlet temperature sensor are integrated into one sensor, and controller of integrated sensor communicates with the engine controller through CAN communication.</li> <li>• For details of access to KDPF differential pressure sensor, wiring harness and tube, see "Chapter 50 DISASSEMBLY AND ASSEMBLY, "REMOVE AND INSTALL KDPF ASSEMBLY" and "DISASSEMBLE AND ASSEMBLE OF KDPF ASSEMBLY".</li> <li>• To restart engine, wait until system operating lamp goes out after turning starting switch to OFF position, and then turn the starting switch to ON position.</li> <li>• Mass air flow sensor and intake air temperature sensor are provided as a unit.</li> </ul>		

No.	Cause	Procedure, measuring location, criteria and remarks
1	Defective intake air temperature sensor	Check the installation of the intake air temperature sensor, if there is a defective installation, install it again correctly.
2	Defective engine controller	If this failure code displays when the ambient temperature is high, the engine controller is defective. (In case of an internal defect, troubleshooting is impossible as an assembly. Replace whole assembly.)

### Circuit diagram related to brake pedal potentiometer

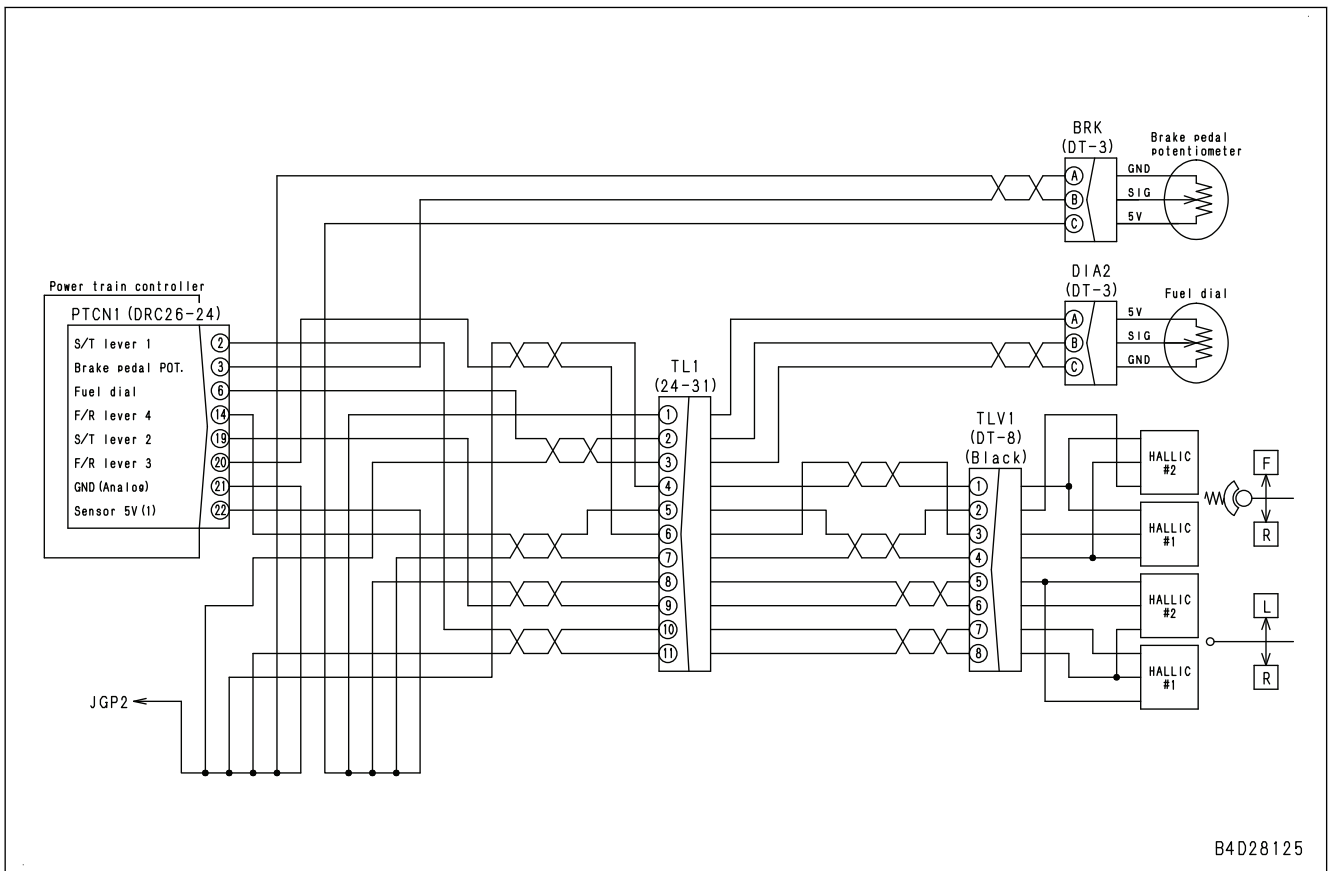

B4D28125

**FAILURE CODE [DKW3L8]**

Action level	Failure code	Failure	Left S/T Lever Potentiometer 1 or 2 Signal Abnormality (Power train controller system)
L03	DKW3L8		
Detail of failure	In left steering lever potentiometer 1 and 2 systems, total of both signal voltages exceeds the specified range.		
Action of controller	<ul style="list-style-type: none"> <li>Makes the alarm lamp light up and alarm buzzer sound.</li> <li>Continues control with signal from normal one of left steering lever potentiometer 1 or 2 systems.</li> <li>Restricts operations of engine and transmission.</li> </ul>		
Phenomenon on machine	<ul style="list-style-type: none"> <li>Once machine stops, engine speed is limited to medium (half) speed.</li> <li>Once machine stops, selectable gear speeds are restricted to F1 and R1.</li> </ul>		
Related information	After completion of repair, check with following operation that the failure code is cleared. Procedure: Turn the starting switch to ON position + Operate right lever.		

No.	Cause	Procedure, measuring location, criteria and remarks
1	Defective circuit related to left steering lever potentiometer	Perform troubleshooting for failure codes [DKW4KA], [DKW4KY], [DKW5KA], and [DKW5KY].

**FAILURE CODE [DR21KX]**

Action level	Failure code	Failure	Camera 2 Picture Reverse Drive Input Out of Range (Machine monitor system)
L01	DR21KX		
Detail of failure			
Action of controller			
Phenomenon on machine			
Related information	<ul style="list-style-type: none"> <li>• This failure code does not relate to this machine because it is not equipped with camera 2. This failure code is provided in case when camera 2 is installed in future.</li> <li>• If this failure code is displayed, see "PROCEDURE FOR TROUBLESHOOTING" to clear this failure code.</li> </ul>		

**FAILURE CODE [DWNKYA]**

Action level	Failure code	Failure	Ladder Clamp Close Solenoid Open Circuit (Optional controller system)
L01	DWNKYA		
Detail of failure	During clamp operation, clamp does not close.		
Action of controller	<ul style="list-style-type: none"> <li>Stops driving the power ladder RAISE solenoid and the power ladder LOWER solenoid.</li> <li>Stops driving the power ladder clump OPEN solenoid and the power ladder clump CLOSE solenoid.</li> <li>Stops driving the electrical pump relay.</li> <li>Turn off the ladder alarm.</li> </ul>		
Phenomenon on machine	<ul style="list-style-type: none"> <li>Ladder RAISE/LOWER operation cannot be performed.</li> <li>Ladder clamp OPEN/CLOSE operation cannot be performed.</li> </ul>		
Related information	The signal condition of power ladder clamp CLOSE solenoid can be checked with monitoring function. (Code: 03728)		

No.	Cause	Procedure, measuring location, criteria and remarks		
1	Defective power ladder clamp CLOSE solenoid	1. Turn the starting switch to OFF position. 2. Disconnect the connector V2B, and connect the T-adapter to male side.		
		Resistance	Between V2B (male) (1) and (2)	2 to 12 Ω
2	Open circuit or short circuit in wiring harness	1. Turn the starting switch to OFF position. 2. Disconnect the connectors OPTCN2 and OPTCN3, and connect the T-adapter to each female side. If resistance value is Min. 1 MΩ, wiring harness has an open circuit. If it is Max. 1 Ω, wiring harness has a short circuit.		
		Resistance	Between OPTCN2 (female) (18) and OPTCN3 (female) (13)	2 to 12 Ω
3	Open circuit in wiring harness	If no failure is found by check on cause 2, this check is not required.		
		1. Turn the starting switch to OFF position. 2. Disconnect the connectors V2B, OPTCN2, and OPTCN3, and connect the T-adapter to each female side.		
		Resistance	Between OPTCN3 (female) (13) and V2B (female) (1)	Max. 1 Ω
Between OPTCN2 (female) (18) and V2B (female) (2)	Max. 1 Ω			
4	Defective optional controller	If no failure is found by preceding checks, optional controller may be defective. (Since this is an internal defect, troubleshooting cannot be performed.)		

**FAILURE CODE [DXH8KY]**

Action level	Failure code	Failure	Transmission Forward Clutch ECMV Solenoid Hot Short Circuit (power train controller system)
L03	DXH8KY		
Detail of failure	<ul style="list-style-type: none"> <li>When controller drives transmission F clutch ECMV solenoid, current constantly flows through circuit.</li> </ul>		
Action of controller	<ul style="list-style-type: none"> <li>Stops driving transmission F clutch ECMV solenoid.</li> <li>Restricts operation of engine and transmission.</li> </ul>		
Phenomenon on machine	<ul style="list-style-type: none"> <li>Once machine stops, engine speed is restricted to medium (half) speed.</li> <li>Once machine stops, it cannot travel at all.</li> </ul>		
Related information	<ul style="list-style-type: none"> <li>Output condition to F clutch ECMV solenoid can be checked with monitoring function. (Code: 31622 T/M Forward Clutch ECMV Current (F/B))</li> <li>After repairing, check if the failure code is cleared by the following procedure. Procedure: Start engine.</li> </ul>		

No.	Cause	Procedure, measuring location, criteria and remarks		
1	Hot short circuit in wiring harness	1. Turn the starting switch to OFF position. 2. Disconnect the connector SFT, and connect the T-adapter to female side. 3. Turn the starting switch to ON position.		
		Voltage	Between SFT (female) (1) and (2)	Max. 4.5 V
2	Defective power train controller	If no failure is found by above checks, power train controller is defective. (Since this is an internal defect, troubleshooting cannot be performed.)		

**Circuit diagram related to transmission forward clutch ECMV solenoid**

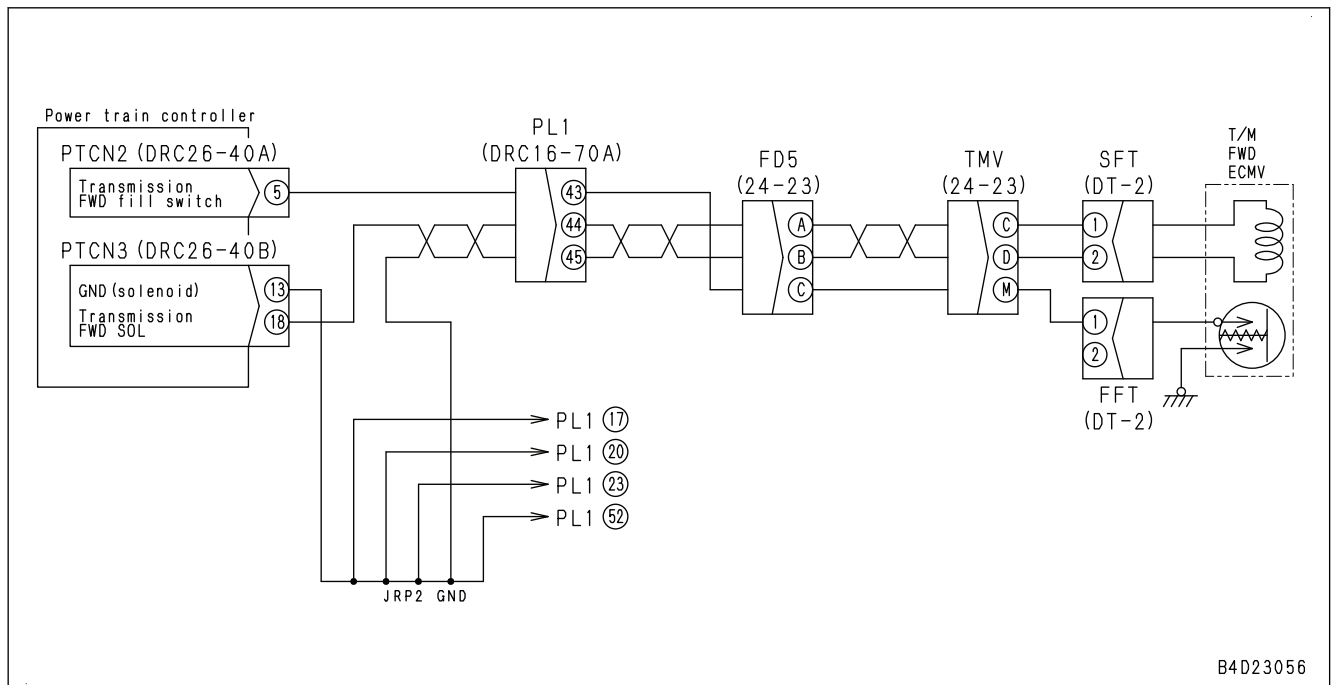

B4D23056

**FAILURE CODE [DXHTKB]**

Action level	Failure code	Failure	Blade Tilt Right Head EPC Solenoid Short Circuit (Work equipment controller system)
L01	DXHTKB		
Detail of failure	When controller drives blade tilt right head EPC solenoid, unusual current flows through circuit.		
Action of controller	Stops driving blade tilt right head EPC solenoid.		
Phenomenon on machine	Right cylinder for blade tilt or pitch cannot be retracted.		
Related information	<ul style="list-style-type: none"> <li>Output condition to blade tilt right head EPC solenoid can be checked with monitoring function. (Code: 90800 RH Blade Tilt Cyl Head EPC Sol (F/B))</li> <li>After repairing, check if the failure code is cleared by the following procedure. Procedure: Turn starting switch to ON position and operate blade control lever (reverse pitch).</li> </ul>		

No.	Cause	Procedure, measuring location, criteria and remarks		
1	Defective solenoid of blade tilt RIGHT head EPC	1. Turn the starting switch to OFF position.		
		2. Disconnect the connector WEP5, and connect the T-adapter to male side.		
		Resistance	Between WEP5 (male) (1) and (2)	2 to 12 Ω
			Between WEP5 (male) (1) and ground	Min. 1 MΩ
2	Ground fault in wiring harness	1. Turn the starting switch to OFF position.		
		2. Disconnect connectors WECN3 and WEP5, and connect the T-adapter to either female side.		
		Resistance	Between ground and either WECN3 (female) (27) or WEP5 (female) (1)	Min. 1 MΩ
3	Short circuit in wiring harness	1. Turn the starting switch to OFF position.		
		2. Disconnect connectors WECN3 and WEP5, and connect the T-adapter to female side of WECN3.		
		Continuity	Between WECN3 (female) (27) and each pin other than (27)	No continuity
4	Defective work equipment controller	If no failure is found by preceding checks, work equipment controller is defective. (Since this is an internal defect, troubleshooting cannot be performed.)		

**FAILURE CODE [DXJ8KB]**

Action level	Failure code	Failure	Blade Tilt Left Bottom EPC Solenoid Short Circuit (Work equipment controller system)
L01	DXJ8KB		
Detail of failure	<ul style="list-style-type: none"> <li>When controller drives blade tilt left bottom EPC solenoid, unusual current flows through circuit.</li> </ul>		
Action of controller	<ul style="list-style-type: none"> <li>Stops driving blade tilt left bottom EPC solenoid.</li> </ul>		
Phenomenon on machine	<ul style="list-style-type: none"> <li>Left cylinder for blade tilt or pitch cannot be extended.</li> </ul>		
Related information	<ul style="list-style-type: none"> <li>Output condition to blade tilt left bottom EPC solenoid can be checked with monitoring function. (Code: 71007 LH Blade Tilt Cyl Bottom EPC Sol (F/B))</li> <li>After repairing, check if the failure code is cleared by the following procedure. Procedure: Turn starting switch to ON position and operate blade control lever (forward pitch).</li> </ul>		

No.	Cause	Procedure, measuring location, criteria and remarks		
1	Defective solenoid of blade tilt LEFT bottom EPC	1. Turn the starting switch to OFF position. 2. Disconnect the connector WEP4, and connect the T-adapter to male side.		
		Resistance	Between WEP4 (male) (1) and (2)	2 to 12 Ω
			Between WEP4 (male) (1) and ground	Min. 1 MΩ
2	Ground fault in wiring harness	1. Turn the starting switch to OFF position. 2. Disconnect connectors WECN3 and WEP4, and connect the T-adapter to either female side.		
		Resistance	Between ground and either WECN3 (female) (38) or WEP4 (female) (1)	Min. 1 MΩ
3	Short circuit in wiring harness	1. Turn the starting switch to OFF position. 2. Disconnect connectors WECN3 and WEP4, and connect the T-adapter to female side of WECN3.		
		Continuity	Between WECN3 (female) (38) and each pin other than (38)	No continuity
4	Defective work equipment controller	If no failure is found by preceding checks, work equipment controller is defective. (Since this is an internal defect, troubleshooting cannot be performed.)		

**FAILURE CODE [F9ATKB]**

Action level	Failure code	Failure	System Operating Lamp Short Circuit (Optional Controller) (Optional controller system)
-	F9ATKB		
Detail of failure	Optional controller determines that output circuit to system operating lamp shorts because voltage of output circuit does not become Low level while optional controller drives system operating lamp.		
Action of controller	<ul style="list-style-type: none"> <li>Stops driving system operating lamp.</li> <li>Even if cause of failure disappears, machine does not become normal until starting switch is turned to OFF position.</li> </ul>		
Problem on machine	None in particular		
Related information	<ul style="list-style-type: none"> <li>Do not turn the battery disconnect switch to OFF position while the system operating lamp is lit. If the battery disconnect switch is turned to OFF position, the memory data of optional controller may be destroyed.</li> <li>Although optional controller cannot make the system operating lamp light up, no trouble will result unless battery disconnect switch is turned to OFF position.</li> <li>When controller makes the system operating lamp light up, output circuit voltage is at low level.</li> <li>After completion of repair, check with following operation that the failure code is cleared. Procedure: Turn the starting switch to ON position.</li> </ul>		

No.	Cause	Procedure, measuring location, criteria and remarks		
1	Hot short circuit in wiring harness	<ol style="list-style-type: none"> <li>Turn the starting switch to OFF position.</li> <li>Disconnect the connector LBUM, and connect the T-adaptor to female side.</li> <li>Turn the starting switch to ON position.</li> </ol>		
		Voltage	Between LBUM (female) (2) and ground	1 Vor less
2	Defective optional controller	If no failure is found by preceding checks, optional controller is defective. (Since this is an internal defect, troubleshooting cannot be performed.)		

CIRCUIT DIAGRAM (BATTERY CHARGE)

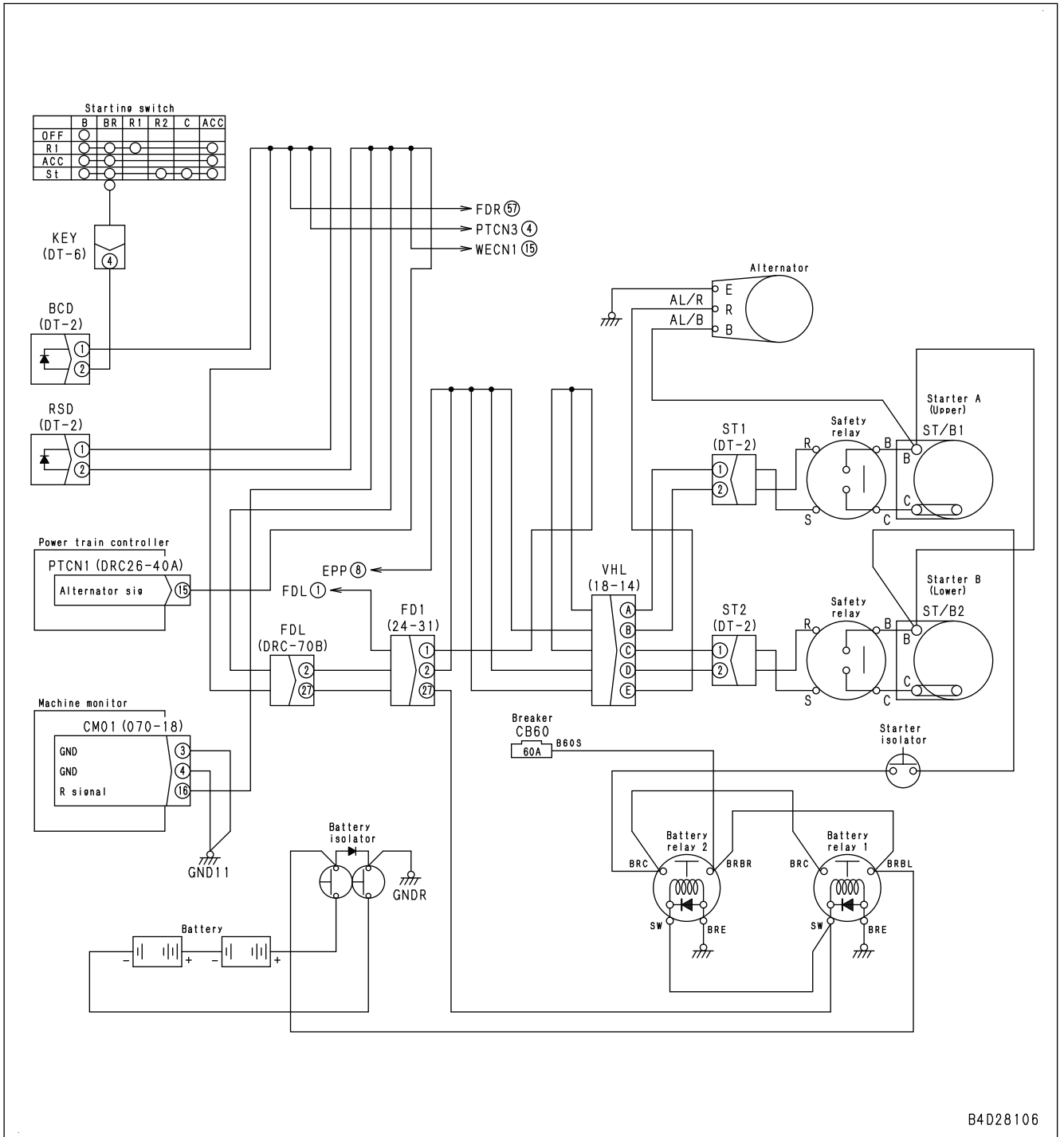

B4D28106

**E-32 HORN DOES NOT SOUND OR DOES NOT STOP SOUNDING (SPECIFICATIONS OF RADIO CONTROL)**

Failure	Horn does not sound or does not stop sounding (specifications of radio control)
Related information	<ul style="list-style-type: none"> <li>If horn does not sound in on-board mode, perform troubleshooting for “Horn does not sound” and “Horn does not stop sounding” in E mode.</li> <li>Output to primary circuit (coil side) of radio control horn relay can be checked with monitoring function. (Code: 03725)</li> </ul>

No.	Cause	Procedure, measuring location, criteria and remarks		
1	Defective radio control transmitter	<ul style="list-style-type: none"> <li>Perform this only when it is operated by radio control except horn.</li> <li>Perform troubleshooting for cause 6 of “Movement of machine does not match to instructions in radio control transmitter operation” in E mode.</li> </ul>		
2	Defective radio control horn relay	<ol style="list-style-type: none"> <li>Turn the starting switch to OFF position.</li> <li>Replace radio control horn relay with another relay.</li> <li>Turn the starting switch to ON position in radio control mode.</li> </ol>		
		If horn operates normally, original radio control horn relay is defective.		
3	Open or short circuit in wiring harness	<ol style="list-style-type: none"> <li>Turn the starting switch to OFF position.</li> <li>Turn the battery disconnect switch to OFF position.</li> <li>Insert T-adapter into connector RHR.</li> <li>Set the radio control/on-board selector switch to “Radio control side” in order of the cab inside and ground side.</li> <li>Turn the battery disconnect switch to ON position.</li> <li>Turn the starting switch to ON position.</li> </ol>		
		Voltage	Between RHR (3) and ground	20 to 30 V
4	Open circuit in wiring harness (Wire breakage or defective contact of connector)	<ol style="list-style-type: none"> <li>Turn the starting switch to OFF position.</li> <li>Turn the battery disconnect switch to OFF position.</li> <li>Disconnect the connectors RHR and HNR, and connect T-adapter to each female side.</li> <li>Turn the battery disconnect switch to ON position.</li> </ol>		
		Resistance	Between RHR (female) (5) and ground	Max. 1 Ω
			Between RHR (female) (3) and HNR (female) (2)	Max. 1 Ω
5	Ground fault in wiring harness (contact with ground circuit)	<p>If no failure is found by check on cause 3, this check is not required.</p> <ol style="list-style-type: none"> <li>Turn the starting switch to OFF position.</li> <li>Turn the battery disconnect switch to OFF position.</li> <li>Insert T-adapter into connector RHR.</li> </ol>		
		Resistance	Between RHR (3) and ground	Min. 1 MΩ
6	Defective optional controller	If no failure is found by preceding checks, optional controller is defective. (Since this is an internal defect, troubleshooting cannot be performed.)		

**E-43 REAR WIPER DOES NOT OPERATE**

Failure	Rear wiper does not operate (failed in both continuous and intermittent operations).
Related information	<ul style="list-style-type: none"> <li>• See E-mode in “NO WIPER OPERATES CONTINUOUSLY OR INTERMITTENTLY“ if a front windshield wiper does not work either.</li> <li>• The wiper motor is driven by the power supplied from front and rear wiper intermittent unit CB26 even during continuous operation.</li> <li>• The wiper motor detects a stop position and pulses 24 V voltage from the fuse.</li> <li>• The wiper motor is driven by 24 V voltage pulse interchanged with front and rear wiper intermittent unit CB26 during intermittent operation.</li> <li>• Pins which are associated with this failure in wiper intermittent unit CB 26 are as follows.                  (3): Continuous 24 V input                  (4): Intermittent 24 V input                  (5): Relay output 2 (power supply 2 to wiper motor)                  (6): 24 V common input                  (7): 24 V pulse input 2 from wiper motor                  (9): GND2</li> <li>• Check an open circuit in wiring harness in pins 5 and 7 of wiper intermittent unit CB26 in this troubleshooting. See E-mode in “NO WIPER OPERATES CONTINUOUSLY OR INTERMITTENTLY“ for an open circuit in other pins.</li> </ul>

No.	Cause	Procedure, measuring location, criteria and remarks			
1	Defective rear wiper motor (internal open circuit)	1. Turn starting switch to OFF position. 2. Disconnect connector CB37, and connect T-adapter to male side.			
		Continuity	Between CB37 (4) and (2)	Continuity	
2	Defective front and rear (F, R) wiper intermittent unit (internal open circuit)	<b>REMARK</b> Check that right and left door wipers operate. 1. Turn starting switch to OFF position. 2. Disconnect connectors CB26 and 27, and switch wiper intermittent units. 3. Turn starting switch to ON position. 4. Turn rear wiper switch to ON position.			
		If rear wiper is normal, originally provided front and rear wiper intermittent unit is defective.			
		Resistance	Reference: Between CB26 (male) (5) and (7)	Max. 1 Ω	
			Reference: Between CB26 (male) (5) and (6)	Min. 1 MΩ	
3	Defective rear wiper switch	1. Turn starting switch to OFF position. 2. Turn battery disconnect switch to OFF position. 3. Disconnect connector CB12, and connect T-adapter to male side. 4. Turn switch to ON and OFF positions, and perform troubleshooting.			
		Resistance	Between CB12 (male) (2) and (3)	OFF	Min. 1 MΩ
			Between CB12 (male) (2) and (3)	ON	Max. 1 Ω

No.	Cause	Procedure, measuring location, criteria and remarks		
5	Defective steering clutch or brake	Be ready with turning starting switch to OFF position, then perform troubleshooting with engine at high idle. If the oil pressure is not normal, perform troubleshooting "H-6 MACHINE CANNOT TURN (STEERING)".		
		Left clutch pressure	Lever: Left stroke end	Min. 2.4 MPa {Min. 24 kgf/cm <sup>2</sup> }
			Lever: Right stroke end	0 MPa {0 kgf/cm <sup>2</sup> }
		Right clutch pressure	Lever: Left stroke end	0 MPa {0 kgf/cm <sup>2</sup> }
			Lever: Right stroke end	Min. 2.4 MPa {Min. 24 kgf/cm <sup>2</sup> }
		Left brake pressure	Lever: Left stroke end	0 MPa {0 kgf/cm <sup>2</sup> }
			Lever: Right stroke end	Min. 2.4 MPa {Min. 24 kgf/cm <sup>2</sup> }
		Right brake pressure	Lever: Left stroke end	Min. 2.4 MPa {Min. 24 kgf/cm <sup>2</sup> }
			Lever: Right stroke end	0 MPa {0 kgf/cm <sup>2</sup> }
		6	Internal defect of transmission	Internal defect of transmission may be occurred. Check it.

**S-1 ENGINE DOES NOT CRANK WHEN STARTING SWITCH IS TURNED TO START POSITION**

Failure	Engine does not crank when starting switch is turned to "START" position
Related information	<ul style="list-style-type: none"> <li>• See E-mode in "ENGINE DOES NOT START (ENGINE DOES NOT CRANK)" for electrical system troubleshooting</li> <li>• If any failure code is displayed, perform troubleshooting for that code first.</li> </ul>

No.	Cause	Point to check, remarks	Remedy
1	Defective starting circuit wiring system	When starting switch is turned to START, starting motor pinion does not pop out.	Perform troubleshooting of "ENGINE DOES NOT START (ENGINE DOES NOT CRANK)" in E mode, and take corrective action.
2	Defective starting motor (safety relay portion)	<ul style="list-style-type: none"> <li>• Starting motor pinion makes grating noise (When starting switch is turned to START position, starting motor pinion pops out).</li> <li>• Starting motor pinion comes off halfway (When starting switch is turned to START position, starting motor pinion pops out).</li> <li>• Starting motor makes flapping sound and does not turn (When starting switch is turned to START position, starting motor pinion protrudes) (Reference: "Flapping sound" means sound made when starting motor pinion pops in and out)</li> </ul>	Perform troubleshooting of "ENGINE DOES NOT START (ENGINE DOES NOT CRANK)" in E mode, and take corrective action.
3	Breakage of flywheel ring gear	If starting motor pinion makes grating noise and the starting motor does not turn, visually check the flywheel ring gear.	Replace if the item is broken
4	A crack on the EGR cooler (Reference: coolant contained in exhaust)	Disconnect the inlet and outlet gas piping of EGR cooler to check if water containing coolant is draining. <b>REMARK</b> Moisture in exhaust gas may be condensed, but this is not a failure. Check if it is coolant or not.	After EGR cooler replacement, drain the water in the engine cylinder.

DISASSEMBLE AND ASSEMBLE STEERING CASE ASSEMBLY .....	50-477
METHOD FOR DISASSEMBLING STEERING CASE ASSEMBLY .....	50-477
METHOD FOR ASSEMBLING STEERING CASE ASSEMBLY .....	50-484
REMOVE AND INSTALL FINAL DRIVE ASSEMBLY .....	50-494
METHOD FOR REMOVING TRAVEL MOTOR AND FINAL DRIVE ASSEMBLY .....	50-494
METHOD FOR INSTALLING FINAL DRIVE ASSEMBLY .....	50-495
DISASSEMBLE AND ASSEMBLE FINAL DRIVE ASSEMBLY .....	50-497
METHOD FOR DISASSEMBLING FINAL DRIVE ASSEMBLY .....	50-498
METHOD FOR ASSEMBLING FINAL DRIVE ASSEMBLY .....	50-504
UNDERCARRIAGE AND FRAME .....	50-514
REMOVE AND INSTALL TRACK FRAME ASSEMBLY .....	50-514
METHOD FOR REMOVING TRACK FRAME ASSEMBLY .....	50-514
METHOD FOR INSTALLING TRACK FRAME ASSEMBLY .....	50-518
REMOVE AND INSTALL IDLER ASSEMBLY .....	50-523
METHOD FOR REMOVING IDLER ASSEMBLY .....	50-523
METHOD FOR INSTALLING IDLER ASSEMBLY .....	50-524
DISASSEMBLE AND ASSEMBLE IDLER ASSEMBLY .....	50-525
METHOD FOR DISASSEMBLING IDLER ASSEMBLY .....	50-525
METHOD FOR ASSEMBLING IDLER ASSEMBLY .....	50-526
REMOVE AND INSTALL RECOIL SPRING ASSEMBLY .....	50-529
REMOVE RECOIL SPRING ASSEMBLY .....	50-530
INSTALL RECOIL SPRING ASSEMBLY .....	50-538
DISASSEMBLE AND ASSEMBLE RECOIL SPRING .....	50-543
METHOD FOR DISASSEMBLING AND ASSEMBLING RECOIL SPRING .....	50-543
METHOD FOR ASSEMBLING RECOIL SPRING ASSEMBLY .....	50-544
REMOVE AND INSTALL TRACK ROLLER ASSEMBLY .....	50-545
METHOD FOR REMOVING TRACK ROLLER ASSEMBLY .....	50-545
METHOD FOR INSTALLING TRACK ROLLER ASSEMBLY .....	50-547
DISASSEMBLE AND ASSEMBLE TRACK ROLLER ASSEMBLY .....	50-549
METHOD FOR DISASSEMBLING TRACK ROLLER ASSEMBLY .....	50-549
METHOD FOR ASSEMBLING TRACK ROLLER ASSEMBLY .....	50-550
REMOVE AND INSTALL NO. 1 BOGIE ASSEMBLY .....	50-552
METHOD FOR REMOVING NO. 1 BOGIE ASSEMBLY .....	50-553
METHOD FOR INSTALLING NO. 1 BOGIE ASSEMBLY .....	50-555
REMOVE AND INSTALL BOGIE ASSEMBLIES .....	50-558
METHOD FOR REMOVING BOGIE ASSEMBLIES .....	50-559
METHOD FOR INSTALLING BOGIE ASSEMBLIES .....	50-562
DISASSEMBLE AND ASSEMBLE TRACK ROLLER BOGEY ASSEMBLY .....	50-564
METHOD FOR DISASSEMBLING TRACK ROLLER BOGEY ASSEMBLY .....	50-564
METHOD FOR ASSEMBLING TRACK ROLLER BOGEY ASSEMBLY .....	50-565
REMOVE AND INSTALL CARRIER ROLLER ASSEMBLY .....	50-567
METHOD FOR REMOVING CARRIER ROLLER ASSEMBLY .....	50-567
METHOD FOR INSTALLING CARRIER ROLLER ASSEMBLY .....	50-567
DISASSEMBLE AND ASSEMBLE CARRIER ROLLER ASSEMBLY .....	50-569
METHOD FOR DISASSEMBLING CARRIER ROLLER ASSEMBLY .....	50-569
METHOD FOR ASSEMBLING CARRIER ROLLER ASSEMBLY .....	50-570
REMOVE AND INSTALL PIVOT SHAFT ASSEMBLY .....	50-574
METHOD FOR REMOVING PIVOT SHAFT ASSEMBLY .....	50-574
METHOD FOR INSTALLING PIVOT SHAFT ASSEMBLY .....	50-575
SEPARATION AND CONNECTION OF TRACK ASSEMBLY .....	50-576
METHOD FOR SEPARATING OF TRACK ASSEMBLY .....	50-576
METHOD FOR INSTALLING TRACK ASSEMBLY .....	50-579
DISASSEMBLY AND ASSEMBLY OF TRACK ASSEMBLY GENERALLY .....	50-581
METHOD FOR DISASSEMBLING TRACK ASSEMBLY GENERALLY .....	50-581
METHOD FOR ASSEMBLING TRACK ASSEMBLY GENERALLY .....	50-584
DISASSEMBLE AND ASSEMBLE ONE TRACK LINK ASSEMBLY IN FIELD .....	50-598
METHOD FOR DISASSEMBLING ONE TRACK LINK ASSEMBLY IN FIELD .....	50-599
METHOD FOR ASSEMBLING ONE TRACK LINK ASSEMBLY IN FIELD .....	50-601

791T-615-1330: Plate

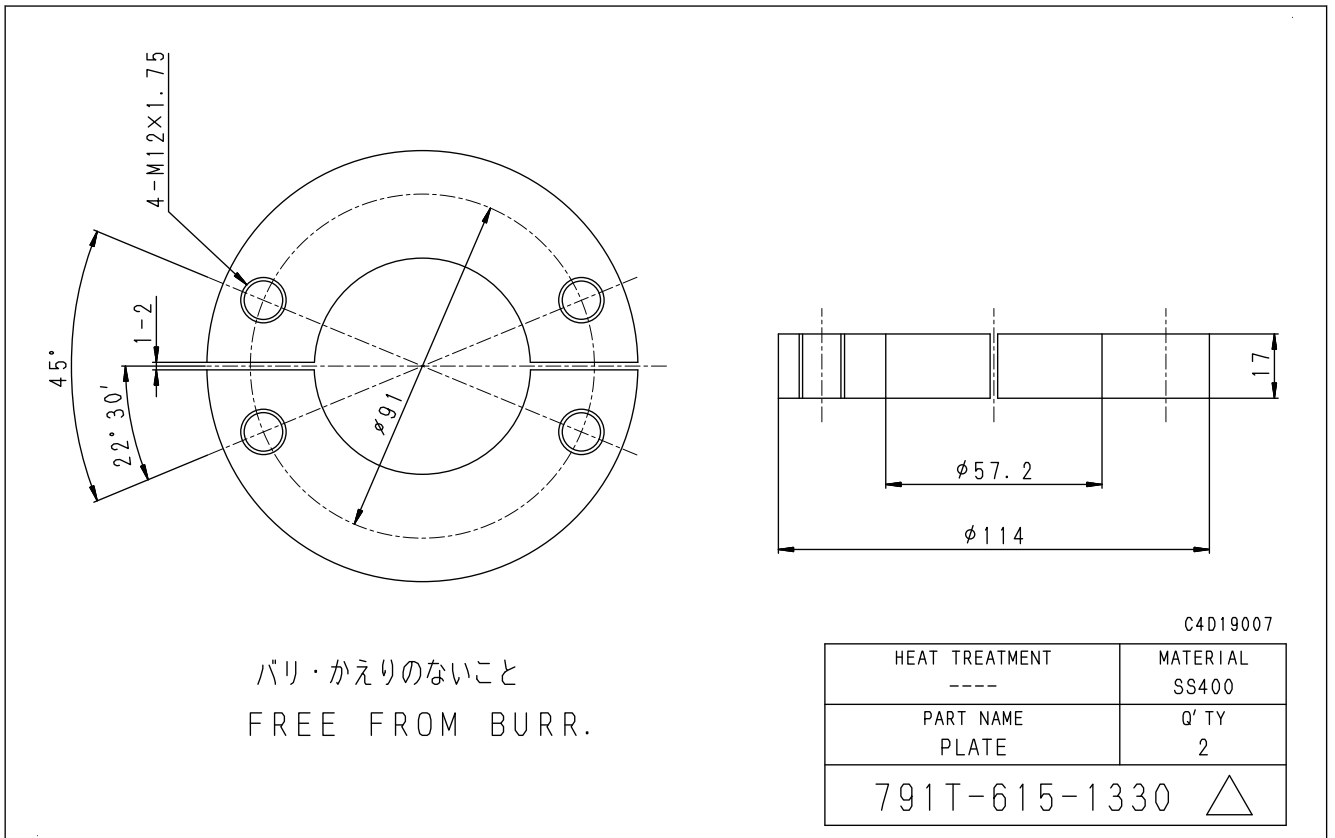

791T-615-1340: Plate

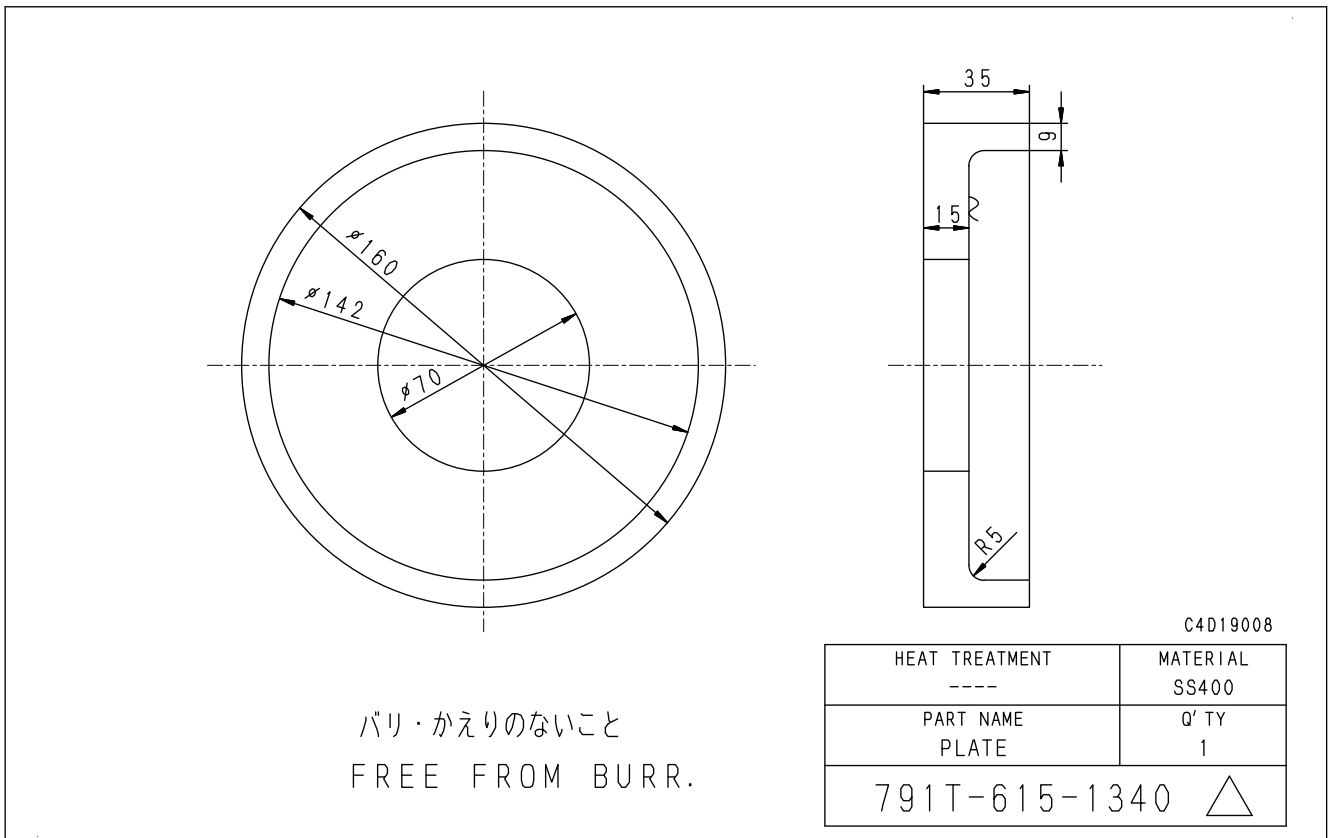



REMOVE AND INSTALL SUPPLY PUMP ASSEMBLY

34. Install the tube (30), and install the sleeve nut (33) and joint bolts (34) and (35).

**REMARK**

Replace the seal washer with a new one.

-  Sleeve nut (33):  
43 to 47 Nm {4.4 to 4.8 kgfm}
-  Joint bolts (34), (35), and (36):  
24.5 to 34.3 Nm {2.5 to 3.5 kgfm}

35. Install the clamp (32) of the tube (30) around the prefilter.

36. Install the tube (28c) with the joint bolt (28b).

-  Joint bolt (28b):  
19.6 to 29.4 Nm {2.0 to 3.0 kgfm}

37. Install the bracket (28d).

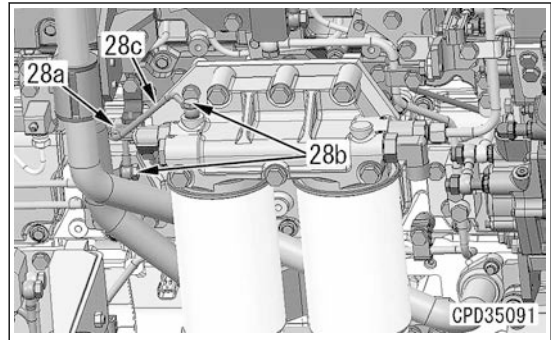

38. Connect the connector PFUEL (28).

39. Install the fuel filter base bracket (27) with the bolts (26) (7 pieces).

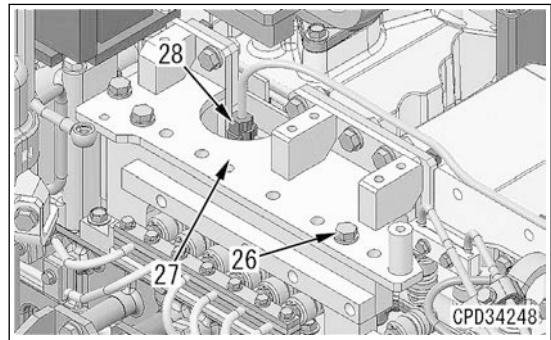

40. Install the bracket (25g) with the bolts (50) (2 pieces).

41. Install the clamp (25e) with the bolt (48).

42. Install the clamp (25f) with the bolt (49).

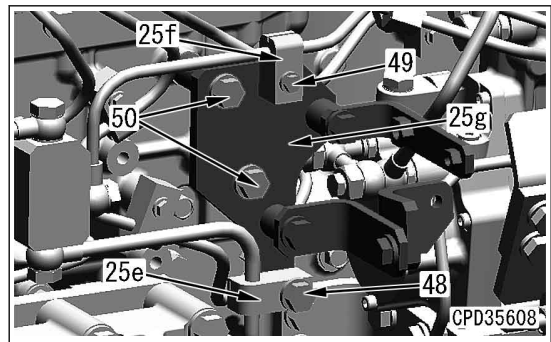

**REMARK**

Install the removed joint bolt to the original position loosely not to lose it.

**METHOD FOR REMOVING CYLINDER HEAD ASSEMBLY**

**Fuel supply valve**

1. Close the fuel supply valve (1a) at the bottom of the fuel tank.

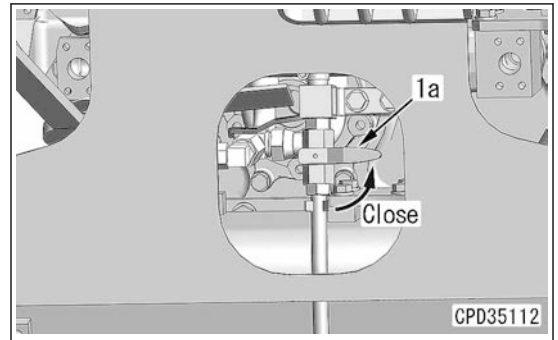

**Draining coolant**

2. Loosen the radiator cap (1), and release the remaining pressure.

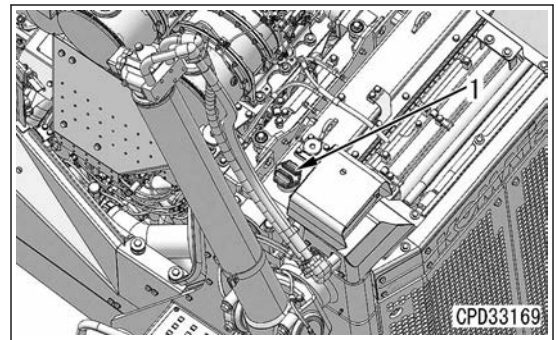

3. Remove the bolts (2) (4 pieces), and open the undercover (3).

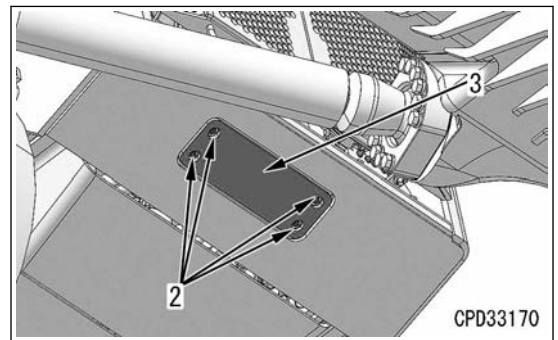

4. Loosen the bolts (4) (2 pieces), and drain coolant.



Radiator:

157 ℓ

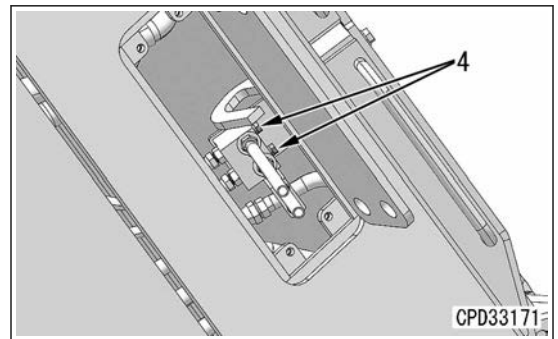

**Engine hood assembly**

5. Remove the engine hood assembly. See "REMOVE AND INSTALL ENGINE HOOD ASSEMBLY".

**Air cleaner bracket assembly**

6. Remove the air cleaner bracket assembly. See "REMOVE AND INSTALL AIR CLEANER ASSEMBLY".

REMOVE AND INSTALL CYLINDER HEAD ASSEMBLY

Supply pump drive case assembly

46. Install O-ring to the inserting part of the flywheel housing of the supply pump drive case (460), sling and install it with the bolts (459) (6 pieces) and (458) (4 pieces).



Supply pump drive case (460):

45 kg

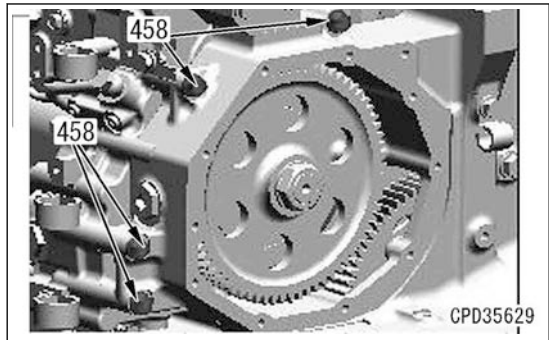
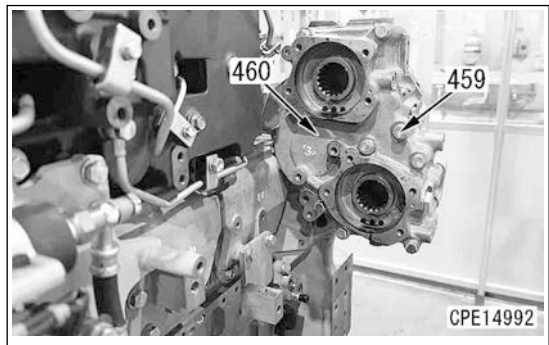

47. Install the supply pump drive gear (457a) with the nut (457).

**NOTICE**

- Align the supply pump drive gear (457a) with the key (a) of the shaft, and install the gear.
- Rotate the crankshaft so that the stamp mark "C" at the part (b) is aligned with the stamp mark "C" of the camshaft gear, and install it.



Nut (457):

333.2 to 352.8 Nm {34 to 36 kgfm}

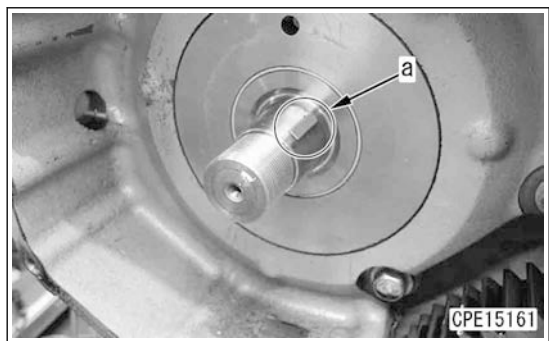
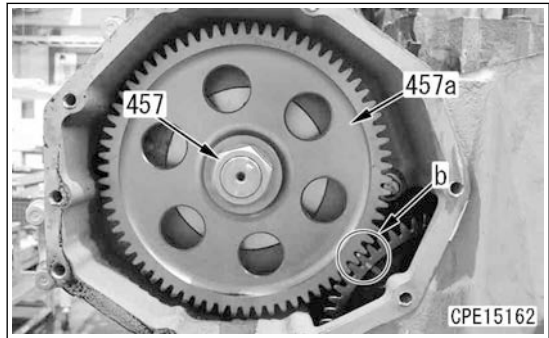

48. Install the bracket (455) with the bolts (454) (5 pieces).  
 49. Install the ambient pressure sensor (455b) with the bolts (455a) (3 pieces).

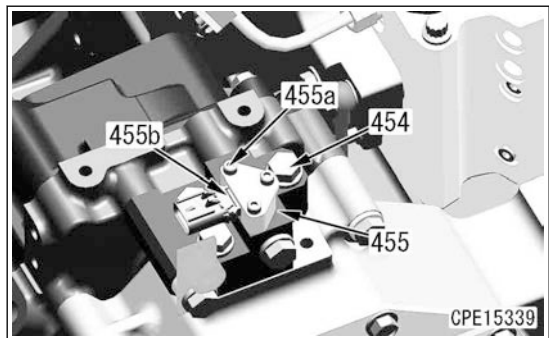

## REMOVE AND INSTALL EGR VALVE ASSEMBLY

- ⚠ Place the machine on a level ground, and set the parking brake lever to LOCK position.
- ⚠ Lower the work equipment to the ground, and set the work equipment lock lever to LOCK position.
- ⚠ Turn the starting switch to OFF position to stop the engine.
- ⚠ Turn the battery disconnect switch to OFF position, and remove the key. (For details, see TESTING AND ADJUSTING, "HANDLE BATTERY DISCONNECT SWITCH".)

### NOTICE

- Check the connector numbers and installed positions before disconnecting wirings and hoses, and write them down.
- Install a plug or flange in the place where a fuel hose is disconnected to prevent oil from flowing out.
- When disconnecting the wires and hoses, take extreme care not to damage or deform the wires and hoses by the clips and clamps. If the wires or hoses may be damaged or deformed, remove the clips and clamps before starting the work.

### REMARK

Install the removed joint bolt to the original position loosely not to lose it.

## METHOD FOR REMOVING EGR VALVE ASSEMBLY

### Engine hood assembly

1. Remove the engine hood assembly. See "REMOVE AND INSTALL ENGINE HOOD ASSEMBLY".

### KDPF assembly

2. Remove KDPF assembly. See "REMOVE AND INSTALL KDPF ASSEMBLY".

### EGR valve

3. Disconnect the connector SEGR (1), and remove it from the connector board (2).
4. Disconnect the connector EGR\_SOL (3), and remove it from the connector board (4).
5. Remove the band (5).
6. Remove the bracket (6) and clamp (7).
7. Remove the joint bolts (8) (2 places) and (9) (2 places), and remove the tubes (10) and (11).
8. Remove the bolts (12) (2 pieces) and bolts (13) (4 pieces), and remove EGR valve assembly (14).

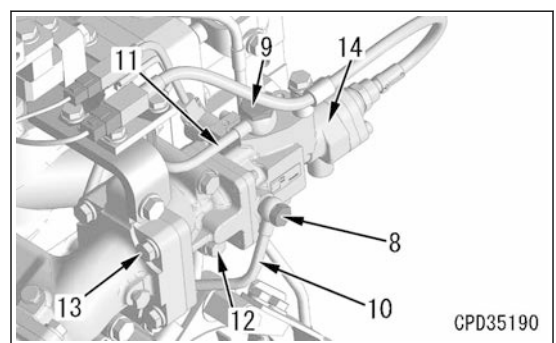
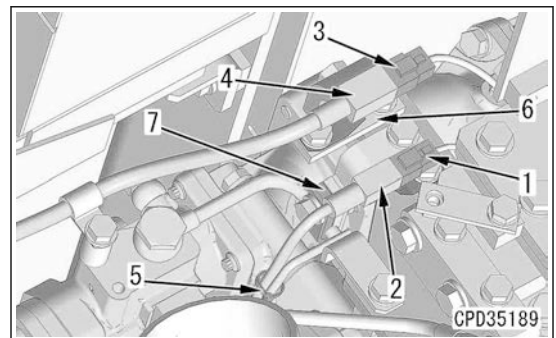

REMOVE AND INSTALL COOLING ASSEMBLY

6. Install the bolt (26a).

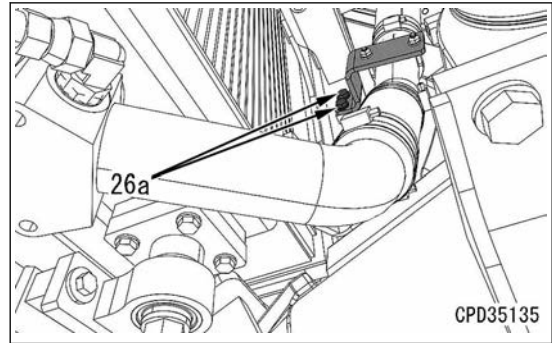

7. Install the brackets (26) (2 places) with the bolts (25) (4 pieces).

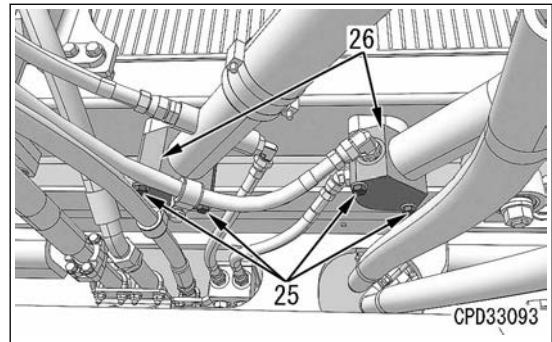

8. Connect the hose (24).

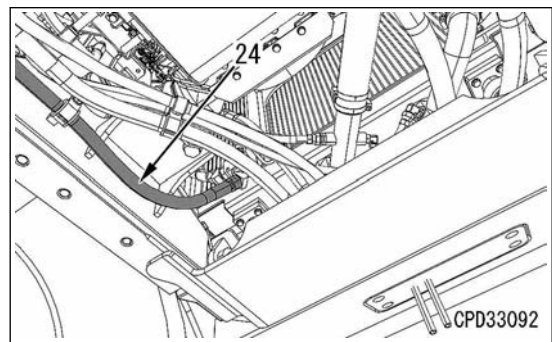

9. Close the underguard (23) with the bolts (22) (12 pieces).

 Underguard (23):  
303 kg

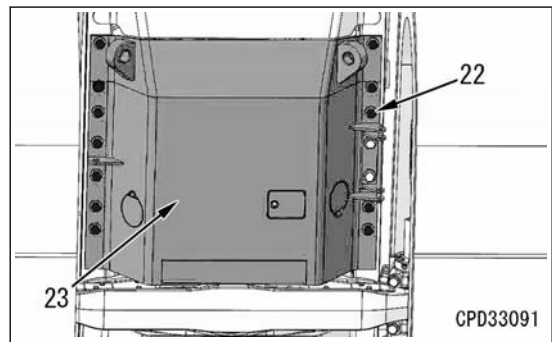

10. Connect the aftercooler lower hose (21), and install the bolts (20) (4 pieces).

 Bolt (20):  
78.5 to 107.9 Nm {8.0 to 11.0 kgfm}

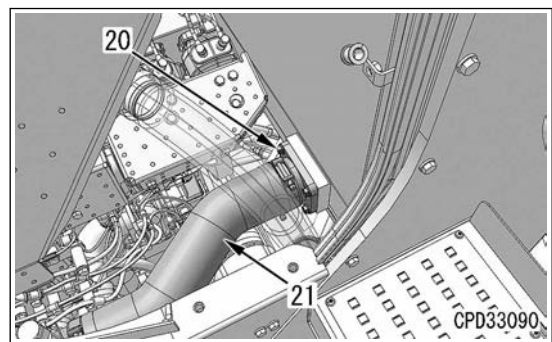

4. Remove the bolts (2) (4 pieces), and open the undercover (3).

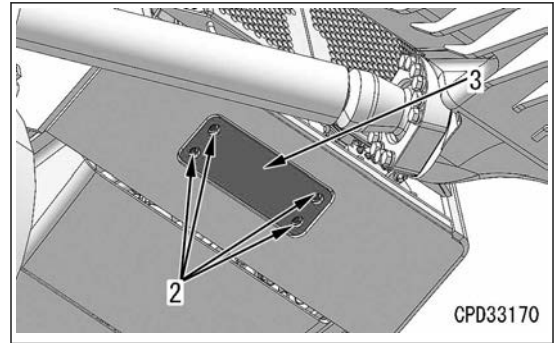

5. Loosen the bolts (4) (2 pieces), and drain coolant.

 Radiator:  
157 ℓ

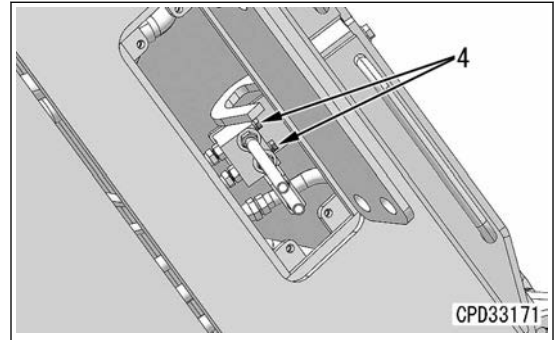

6. Remove the bolts (5) (12 pieces), and open the underguard (6).

 Underguard (6):  
319 kg

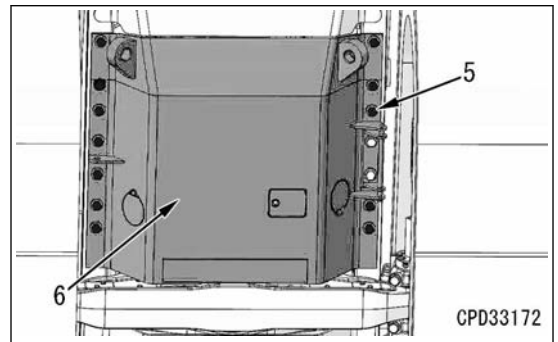

7. Loosen the bolt (7), and drain the coolant.

 Power train oil cooler:  
10 ℓ

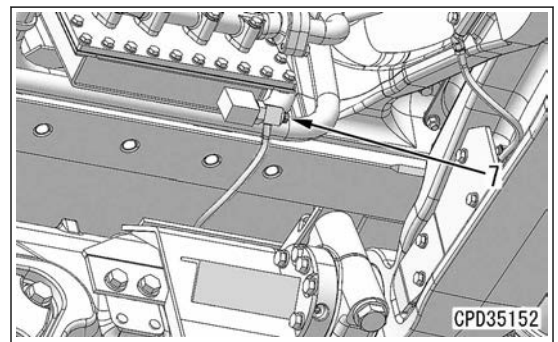

8. Close the fuel drain valve (8).

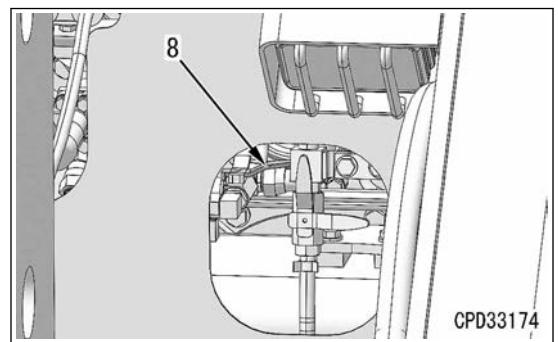

**Collecting refrigerant**

9. Collect the refrigerant (air conditioner gas: R134a) from the air conditioner circuit.

## REMOVE AND INSTALL ENGINE HOOD ASSEMBLY

- ⚠ Place the machine on a level ground, and set the parking brake lever to LOCK position.
- ⚠ Lower the work equipment to the ground, and set the work equipment lock lever to LOCK position.
- ⚠ Turn the starting switch to OFF position to stop the engine.
- ⚠ Turn the battery disconnect switch to OFF position, and remove the key. (For details, see TESTING AND ADJUSTING, “HANDLE BATTERY DISCONNECT SWITCH”.)

### METHOD FOR REMOVING ENGINE HOOD ASSEMBLY

#### Small hood

1. Remove the bolts (1) (4 pieces), and remove the cover (2).

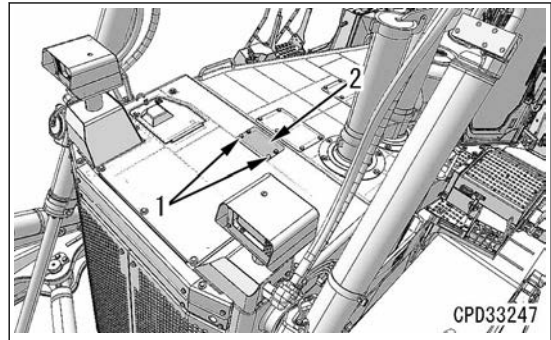

2. Install the lifting tool to the slinging positions (a), sling and hold it.

 Small hood (5):  
46 kg

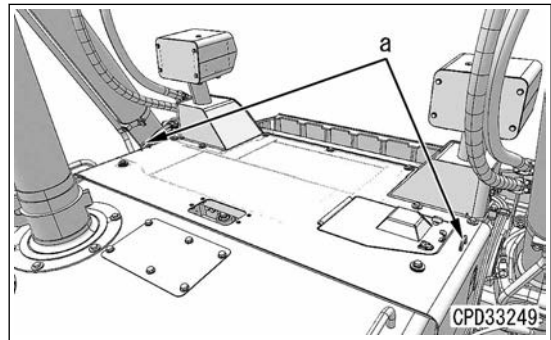

3. Remove the bolts (4) (9 pieces), and remove the small hood (5).

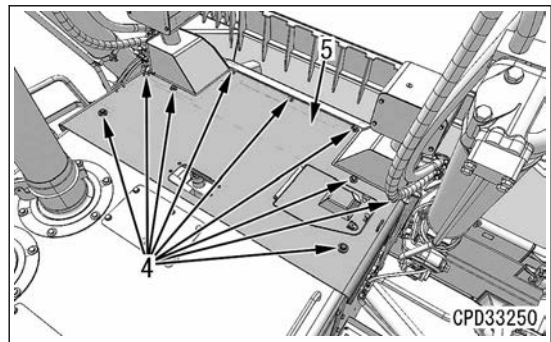

4. Disconnect the connector RDG1 (3).

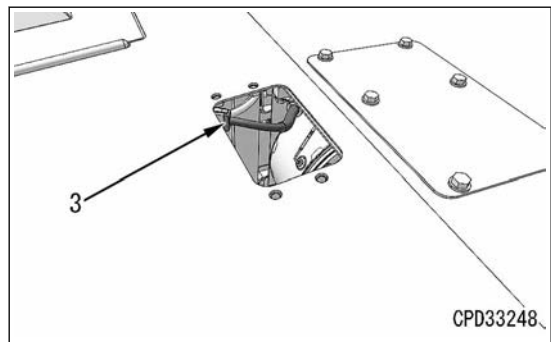

**Temperature sensor**

- Remove the clamps (7) (6 places) of KDPF temperature sensor (6).

**NOTICE**

Put the marks on the clamp installing positions.

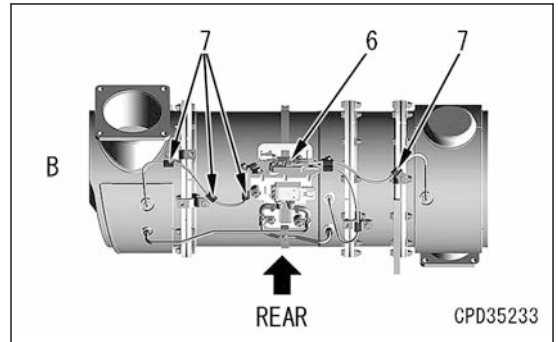
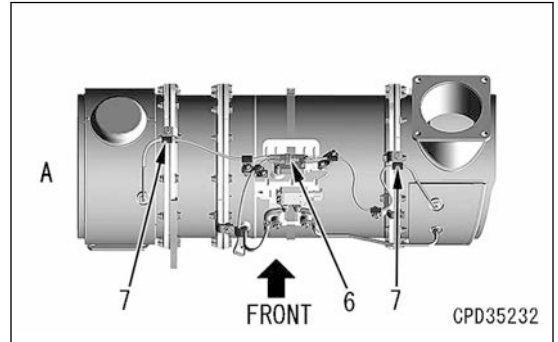

**REMARK**

- Installing positions of KDPF (A) on the front side of the machine body are different from those of KDPF (B) on the rear side of the machine body.
- Do not remove the bolt of the clamp (d), but remove the bolt (8) used for installing the sensor table and bracket.

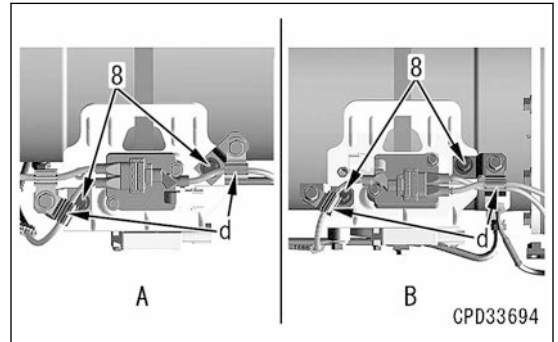

- Loosen the nuts (9) and (10), hold the metal portions (e) of KDOC inlet temperature sensor (11) and KDOC outlet temperature sensor (12) by hand, and pull them out straight in the direction of the arrow.

**REMARK**

Nut (9) (width across flats): 17 mm

Nut (10) (width across flats): 17 mm

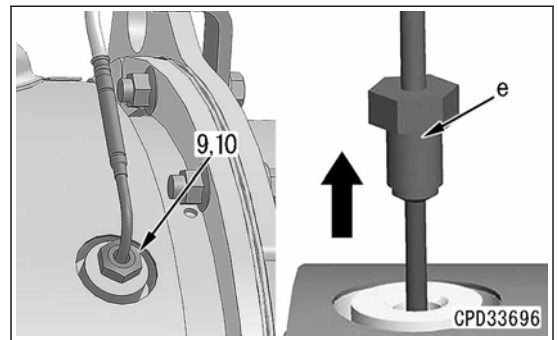
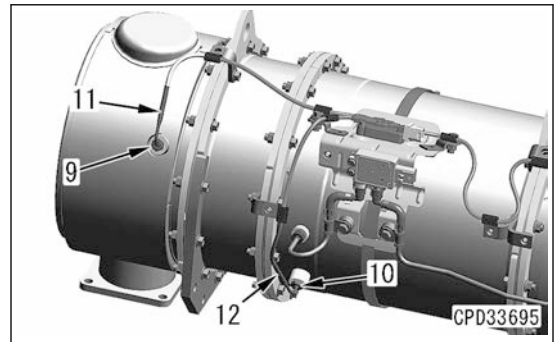

REMOVE AND INSTALL VGT ASSEMBLY

51. Install the bellows cover (12) with the bolts (11) (6 pieces).

-  Threaded portion of bolt (11):  
Seizure prevention compound (LC-G)

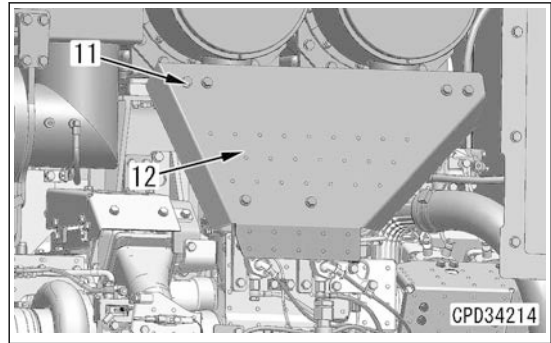

52. Install the cover (10) with the bolts (9) (8 pieces).

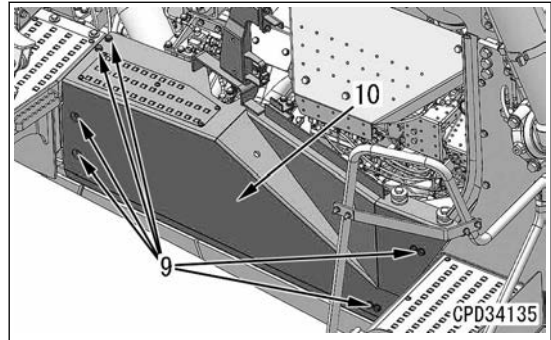

53. Install the rubber covers (8) (2 places).

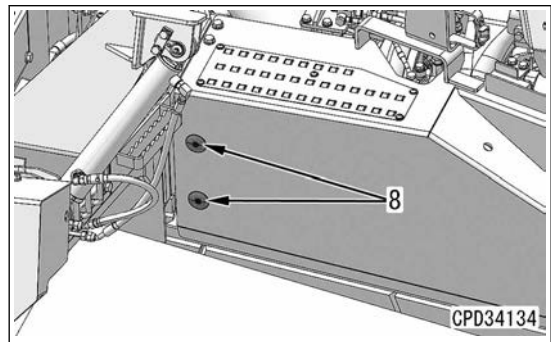

54. Install the cover (7) with the bolts (6) (4 pieces).

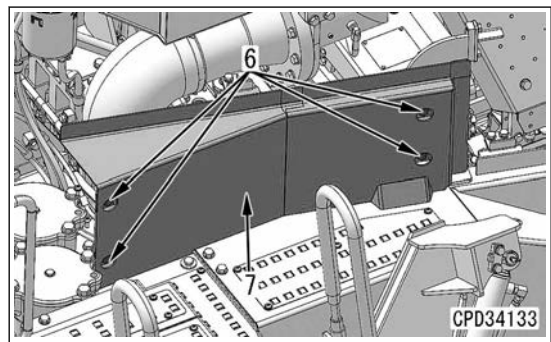

55. Install the rubber covers (5) (4 places).

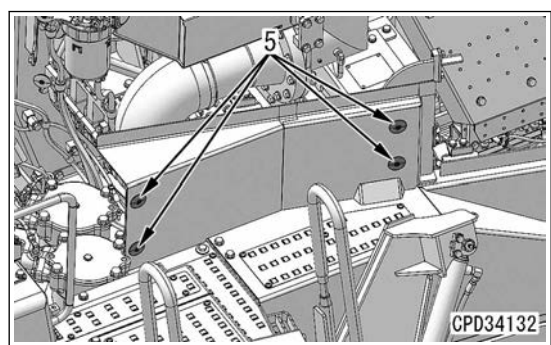

34. Remove the bolt (11).

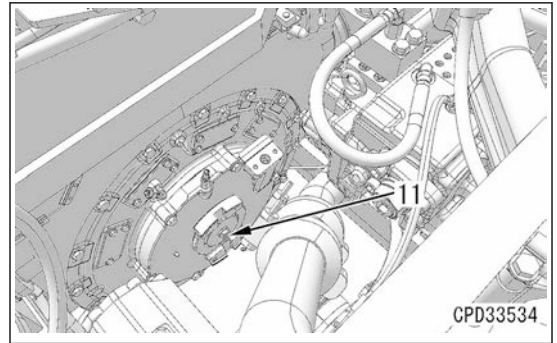

35. Remove the holder (12).

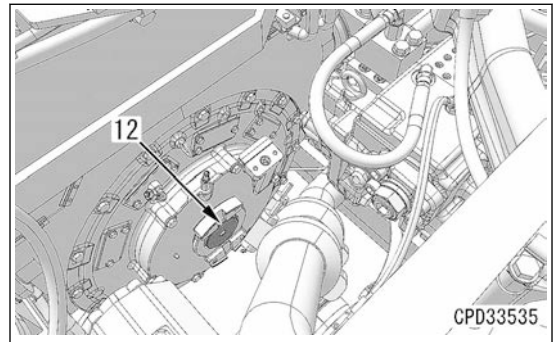

36. Remove the coupling (13).

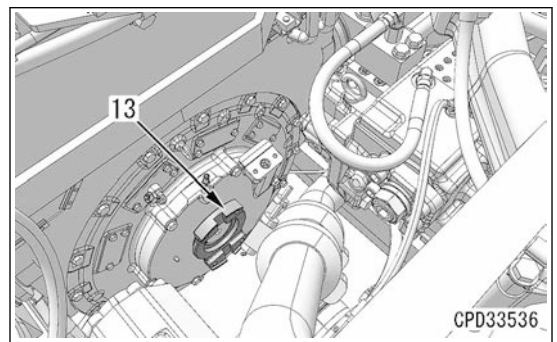

37. Remove the damper cover (14) according to the following procedure.

- 1) Sling the damper cover (14) by using the eyebolt, and hold it.



Damper cover (14):

75 kg

- 2) Install the guide bolt.

**REMARK**

Be sure to use the guide bolt (A) to prevent the damper cover from coming off suddenly. (M12 x 1.75 x 200 mm)

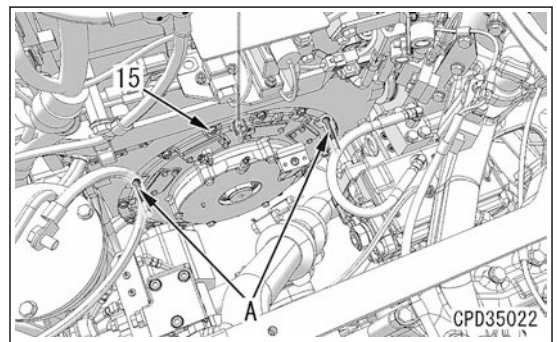

38. Remove the bolts (15) (16 pieces).

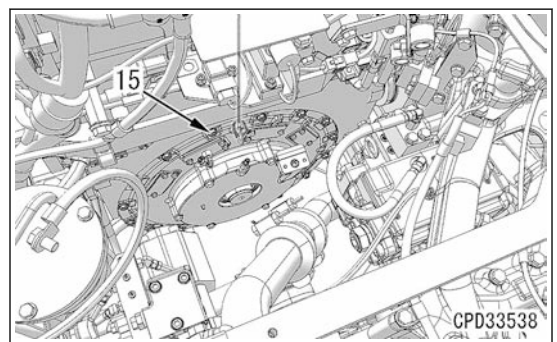

REMOVE AND INSTALL POWER TRAIN UNIT ASSEMBLY

25. Connect the hose (48), and install the clamps (47) (2 pieces).

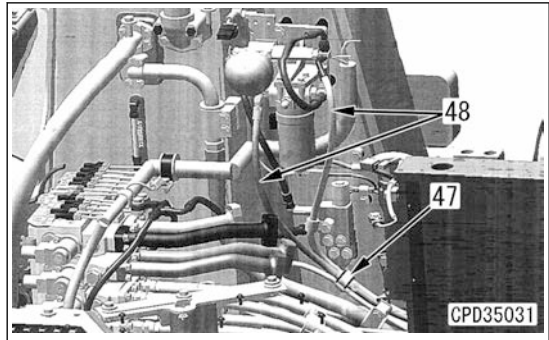

26. Install the bracket (46) with the bolts (45) (4 pieces).

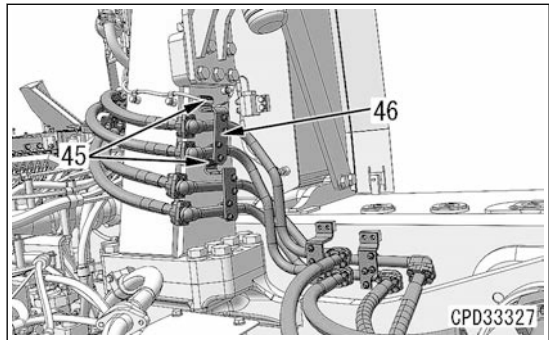

27. Install the connector LS2 (43) to the connector board (44).

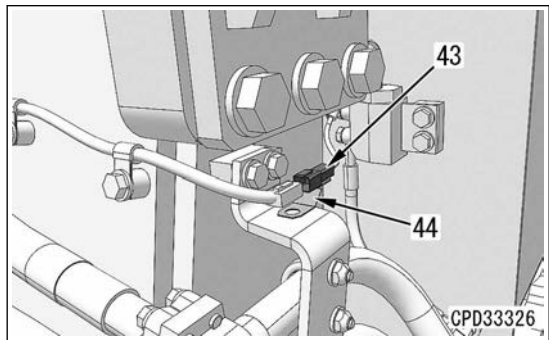

28. Connect the connector LS2 (43).

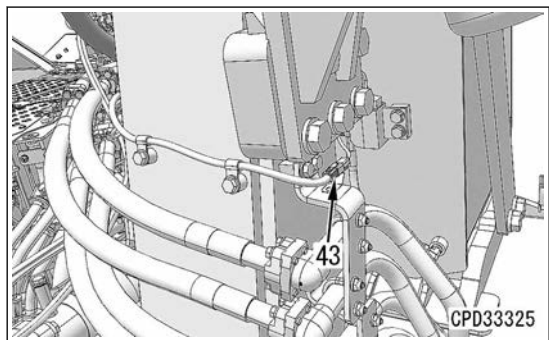

29. Install the bolts (42) (4 pieces).

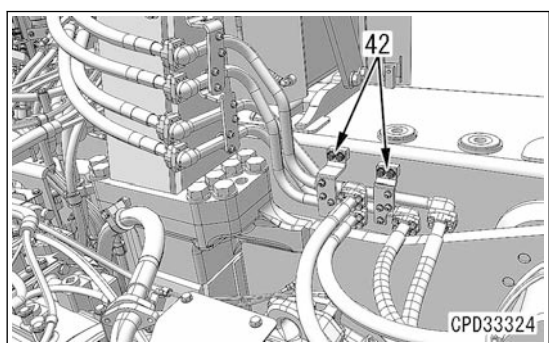

**Power train pump gear assembly**

16. Install O-ring, and install the cover (14).
17. Install the bearings (11) and (12) to the gear (13) by using the push tool (D).

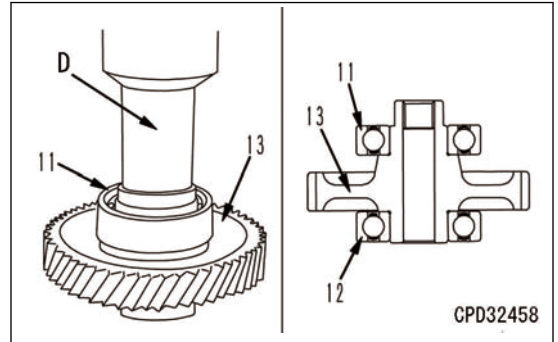

18. Press fit the gear assembly (10) into the cover (9) by using the push tool (D).

 Gear spline:  
Molybdenum disulfide lubricant (LM-S)

19. Install O-ring, sling the cover assembly (8), and install it to the case.

**REMARK**

If the cover assembly is stuck and cannot be inserted into the case easily, tap the periphery of the cover assembly by using a plastic hammer, etc., and install it.

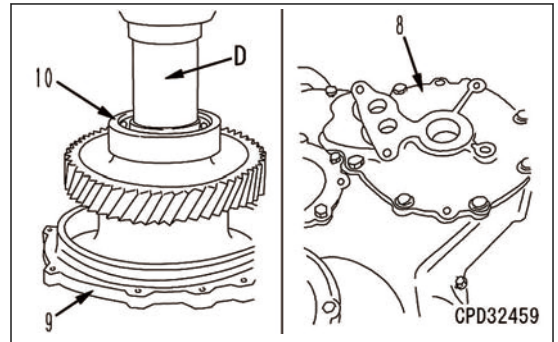

**Work equipment and PPC pump gear assembly**

20. Press fit the bearings (5) and (6) into the gear (7) by using the push tool (D).

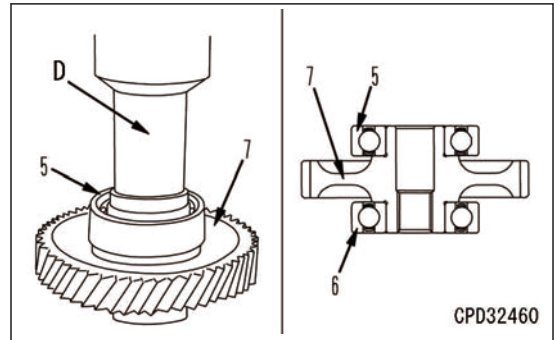

21. Press fit the gear assembly (3) into the cover (4) by using the push tool (D).

**REMARK**

Press fit the assembly while the side on which the bearing end surface is flush with the gear end surface faces the cover.

 Gear spline:  
Molybdenum disulfide lubricant (LM-P)

22. Install O-ring, sling the cover assembly (2), and install it to the case.

**REMARK**

If the cover assembly is stuck and cannot be inserted into the case easily, tap the periphery of the cover assembly by using a plastic hammer, etc., and install it.

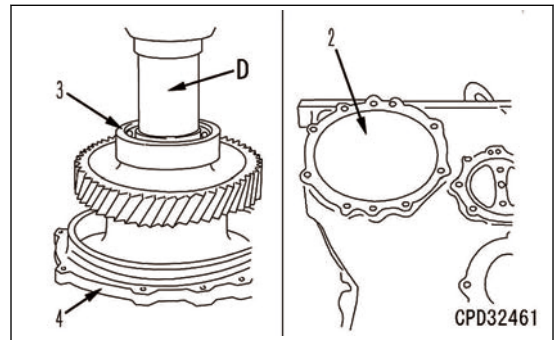

23. By using the eyebolt (C), align the No.4 housing assembly (85) with the dowel pin, and install it.

**REMARK**

Drive in the dowel pin with a plastic hammer, etc. until the clearance between the mating faces disappears.

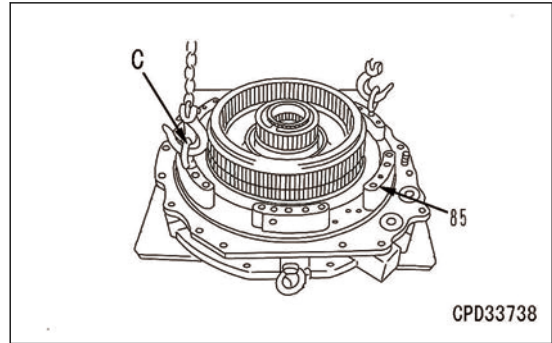

**No.4 disc, plate, spring**

24. Install the torque pins (84) (6 pieces).  
Torque pin length: 162 mm
25. Install the guide plate (147), and install the disc (81), springs (83) (3 pieces each), and plates (82) (2 pieces) alternately.

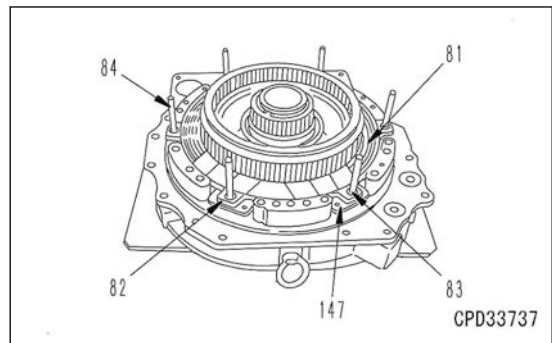

**No.3, No.4 clutch plate**

26. By using the eyebolt (C), align the plate (80) with the dowel pin, and install it.

**REMARK**

Drive in the dowel pin with a plastic hammer, etc. until the clearance between the mating faces disappears.

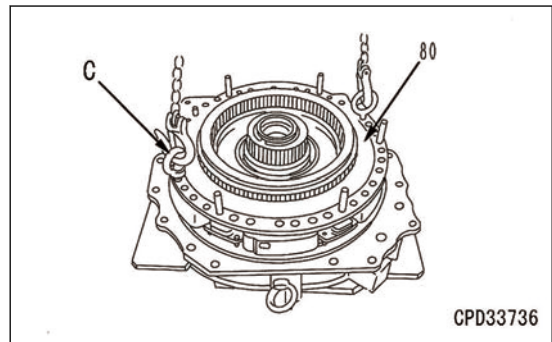

**No.3 disc, plate, spring**

27. Install the disc (77), springs (79) (4 pieces each), and plates (78) (3 piece) alternately.
28. Install the guide pins (54) (12 pieces).  
Guide pin length: 360 mm
29. Install the springs (76) (12 pieces), and install the guide plate.
- Free length of spring: 97 mm

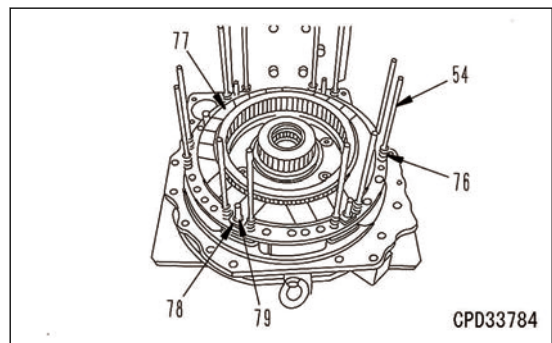

**Hub**

5. Remove the plate (3).
6. By using the lifting tool, sling the hub (4), and remove it.

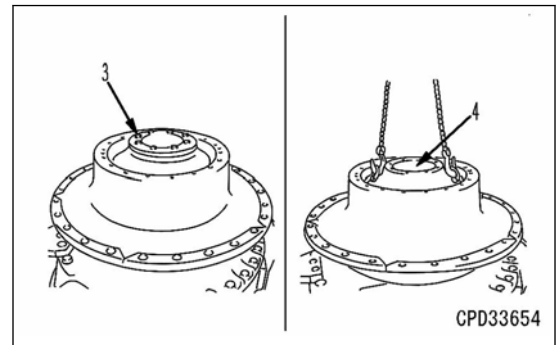

**Sprocket hub assembly**

7. Remove the holder (5).

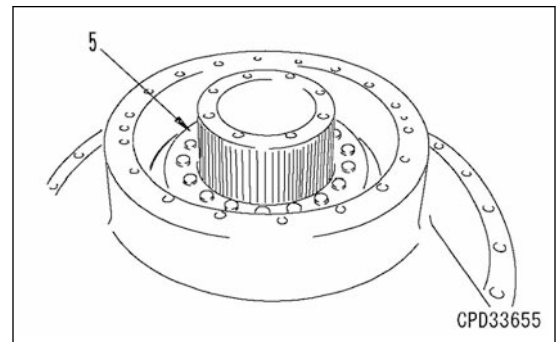

8. Separate the sprocket hub assembly (6) and bearing (7) from each other by using the remover (A).
9. Remove the sprocket hub assembly (6) by using the lifting tool.

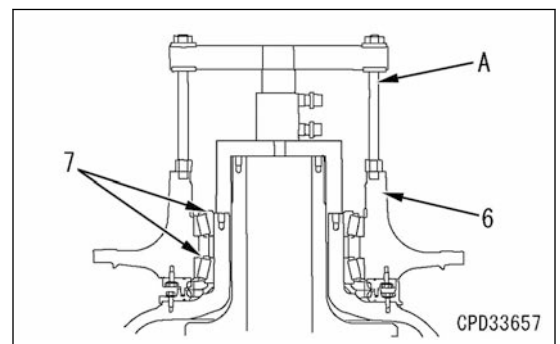
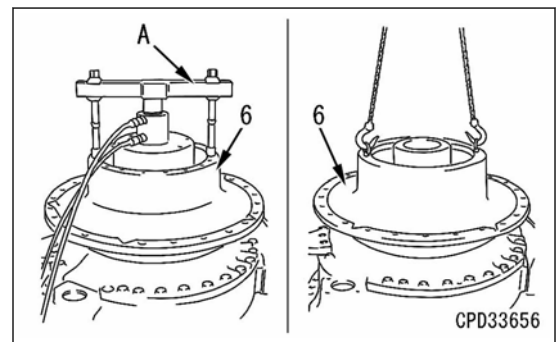

10. Remove the bearing inner race (8) from the sprocket hub assembly.

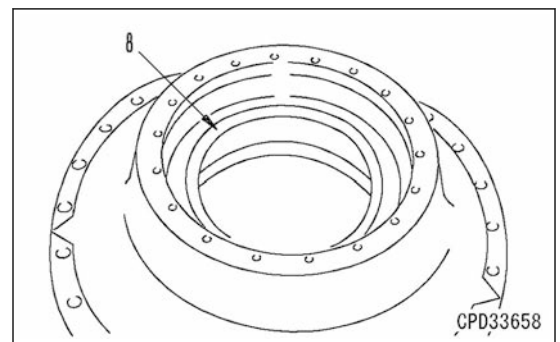

REMOVE AND INSTALL RECOIL SPRING ASSEMBLY

8. Remove the 12 bolts (7), lift the trunnion (8), and remove it.

Tool: Ratchet handle, socket, webbing sling (A)

Bolt (7): Width across flats 41 mm, M27

 Trunnion (8): 75 kg

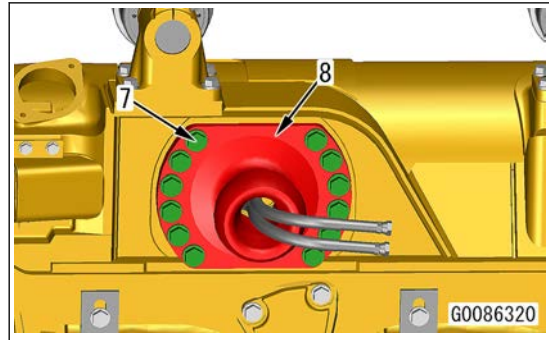

9. Remove the 6 bolts (9), and remove the cover (10).

**REMARK**

Do the same work on the opposite side, too.

Tool: Ratchet handle, socket

Bolt (9): Width across flats 24 mm, M16

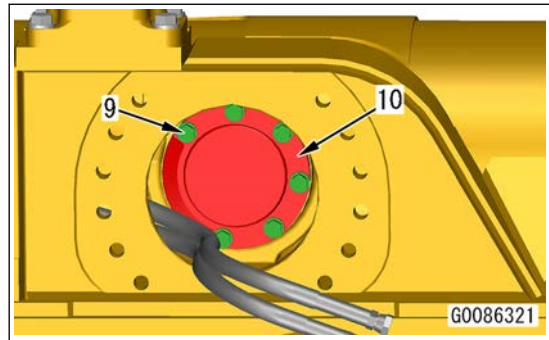

10. Remove the pin (11).

**REMARK**

- After the pin at one side is removed, the other pin at the opposite side cannot be pulled out easily. Remove the inner pin first.
- Do the same work on the opposite side, too.

Tool: Puller (D)

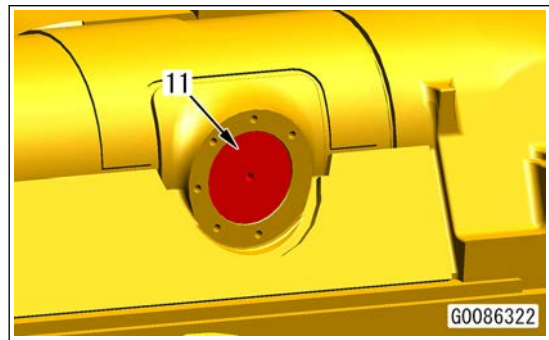

11. Remove the idler and recoil spring assembly (12) as follows.

- 1) Install the pin (E) and webbing sling (A) to the lifting points (a) and (b), lift the idler and recoil spring assembly (12), and hold it.

Tool: Pin (E), webbing sling (A)

 Force to hold idler and recoil spring assembly (12): Approximately 500 kg

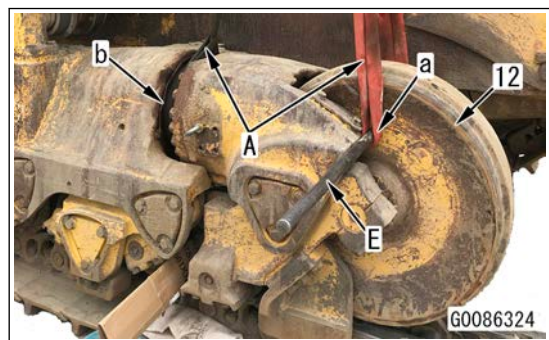

5. Disconnect the inner bogie (6) and outer bogie (7).

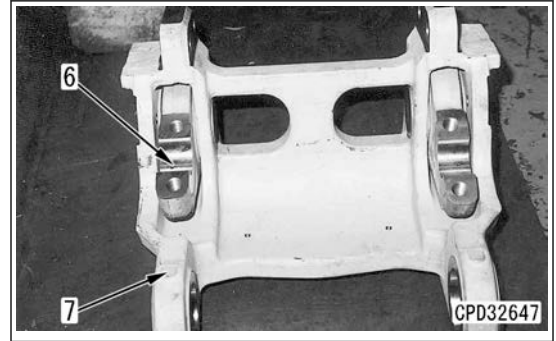

## METHOD FOR ASSEMBLING TRACK ROLLER BOGEY ASSEMBLY

### Assembling the pin assembly

1. Assemble the pin assembly. See "Assembling method of the bogie assembly", "Assembling the pin assembly".
2. Set the inner bogie (6) on the outer bogie (7).

### Press fitting the pin assembly

3. Set the puller (A) and cover (5).
4. Press fit the pin assembly.

#### REMARK

- Insert the pin assembly so that the part (a) of the end surface faces upward (with installed to the machine).
- Push the pin assembly by using the cover (5).
- Push the pin assembly up to the bogie machined surface so that the step (b) between the bogie and pin assembly is 5 mm.
- Press-fitting force of pin assembly 245 to 441 kN {25 to 45 t}

 Pin periphery surface:  
Molybdenum dioxide lubricant (LM-P)

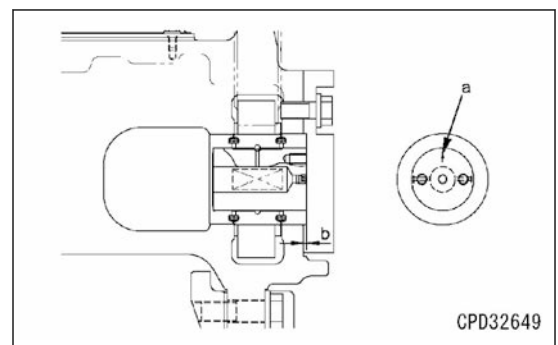
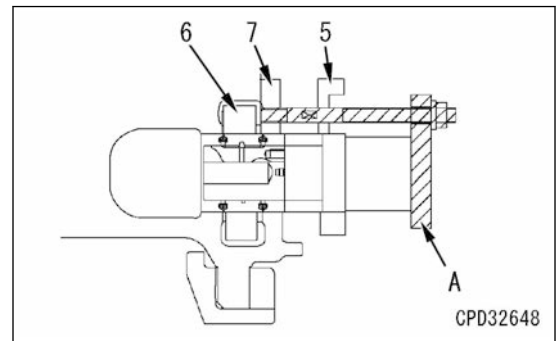

### Refilling with oil

5. By using the oil pump (B), fill the pin assembly with the specified capacity of oil.

#### REMARK

Oil pressure when filling: 0.49 MPa {5 kgf/cm<sup>2</sup>}

 Pin assembly:  
90 to 115 cc (GO140)

6. Install the pin assembly on the opposite side according to the same procedure.

#### REMARK

After press fitting the pin assembly, slide the inner bogie so that it can move lightly.

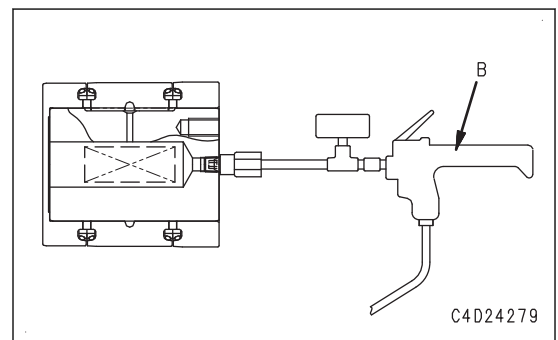

**DISASSEMBLE AND ASSEMBLE ONE TRACK LINK ASSEMBLY IN FIELD**

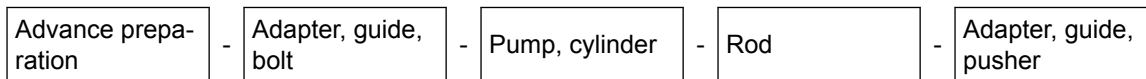

**Tools to be used when disassembling and assembling one track link assembly in field**

Symbol	Part No.	Part name	Necessity	Q'ty	New/Redesign	Sketch	Remarks
-	791-632-1100	Remover and installer assembly	■	1			Disassembly of one track link assembly
1	791-632-1130	• Adapter		1			
2	790-434-1610	• Guide		1			
3	01010-51440	• Bolt		2			
4	791-685-9510	• Frame		1			
5	791-685-9530	• Rod		1			
6	791-685-9520	• Frame		1			
7	791-685-9550	• Nut		3			
8	04530-12030	• Eyebolt		1			
9	791-685-9560	• Bolt		4			
10	791-126-0150	• Adapter		1			
11	791-685-9540	• Rod		1			
12	791-632-1140	• Adapter		1			
13	791-680-5520	• Guide		1			
A	14	01010-51030	• Bolt	1			
15	791-632-1150	• Pusher		1			
16	791-685-9620	• Extension		1			
17	791-632-1180	• Adapter		1			
18	791-680-5543	• Adapter		1			
19	791-632-1170	• Guide		1			
20	791-680-5551	• Guide		1			
21	791-680-9630	• Adapter		1			
22	791-632-1160	• Guide		1			
23	195-32-61210	• Bolt		2			
24	790-101-4300	• Cylinder (1470 kN {150 t})	■	1			Assembly of one track link assembly
25	790-101-1102	• Pump	■	1			
26	790-101-4200	• Cylinder (294 kN {30 t})	■	1			
27	791-680-1630	• Spacer	■	1	N	○	

9. Disconnect the connector LS1 (12).

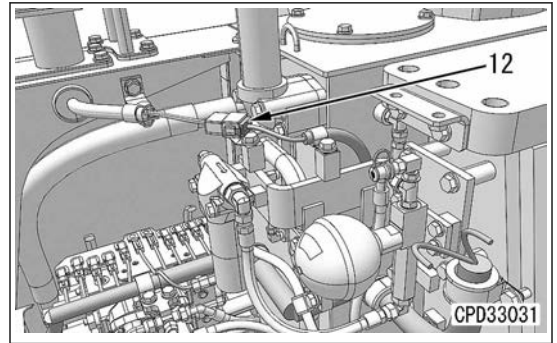

10. Remove the disconnected connector LS1 (12) from the connector board (13).

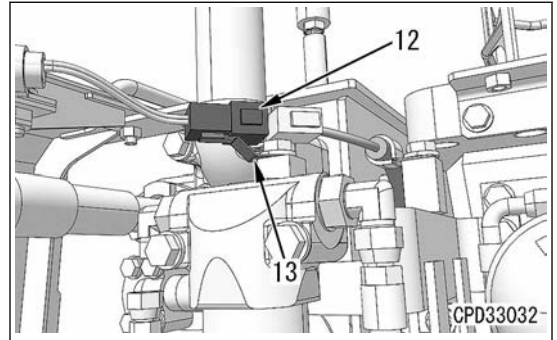

11. Remove the bolts (14) (3 pieces), and remove the cover (15).

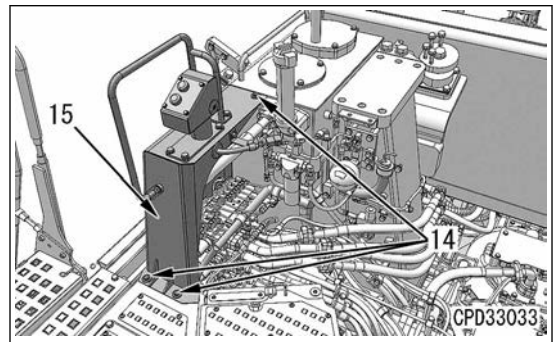

12. Disconnect the hose (16).

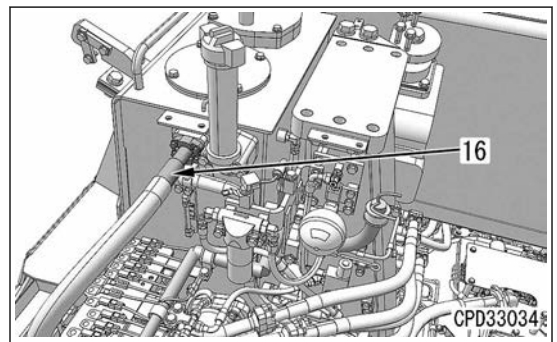

13. Disconnect the hose (17).

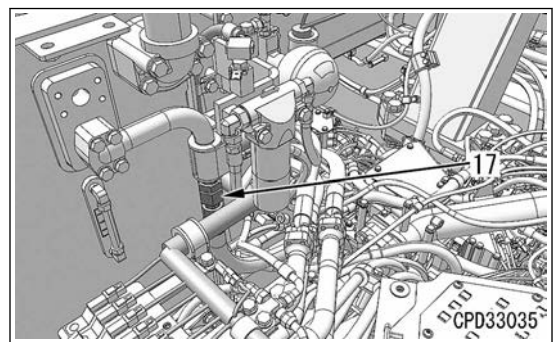

REMOVE AND INSTALL CONTROL VALVE ASSEMBLY

- 3. Connect the hose (42).

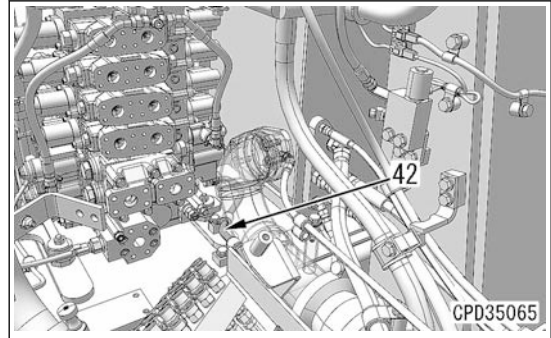

- 4. Connect the connector HHP (41).

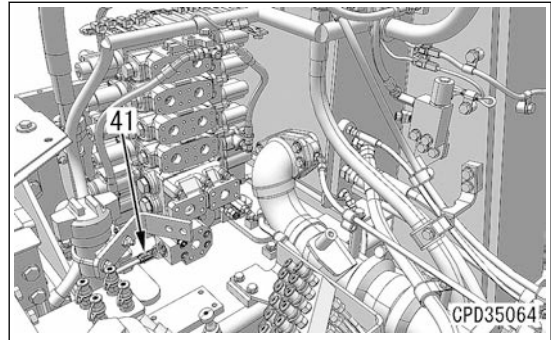

- 5. Connect the hose (40).

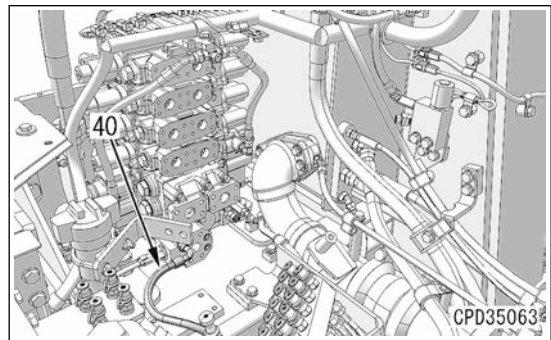

- 6. Connect the hoses (39) (2 pieces).

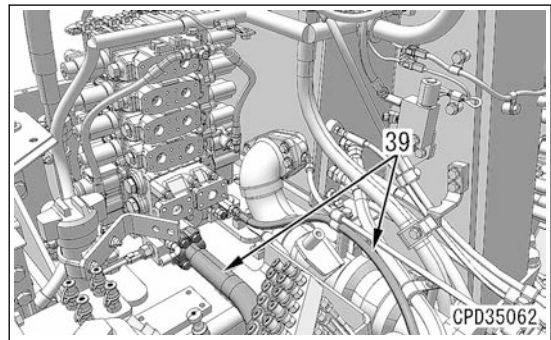

- 7. Connect the hoses (38) (2 pieces).

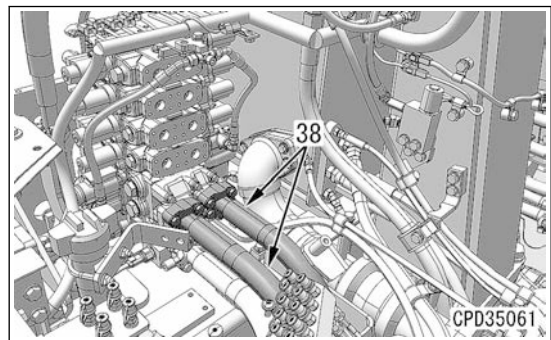

**Beam, arm**

12. Sling the beam (11), hold it, remove the R.H. and L.H. pins (12), and then remove the beam (11).

 Beam:  
2000 kg

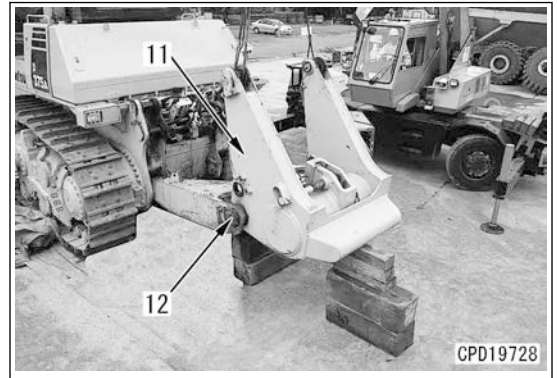

13. Sling the arm (13), hold it, remove the R.H. and L.H. pins (14), and then remove the arm (13).

 Arm:  
1000 kg

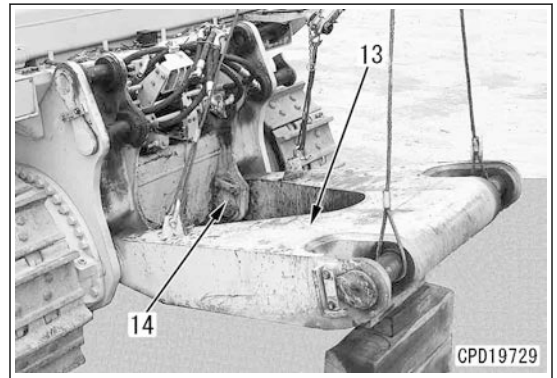

**METHOD FOR ASSEMBLING GIANT RIPPER ASSEMBLY**

**Beam, arm**

1. Sling the arm (13), set it to the installing position, fit the R.H. and L.H. pins (14), and fix it with the lock plate.

 Arm (13):  
1000 kg

2. Set the stand under the arm.

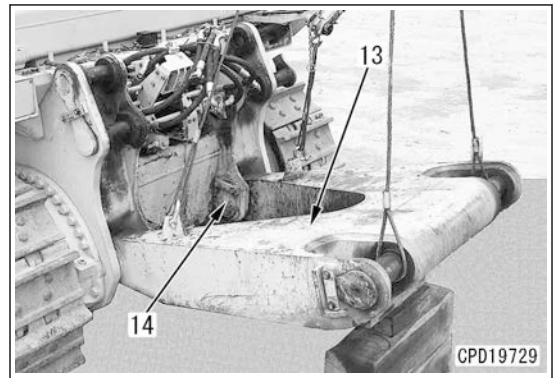

3. Sling the beam (11), set it to the installing position, fit the R.H. and L.H. pins (12), and fix it with the lock plate.

 Beam (11):  
2000 kg

4. Set the stand under the beam.

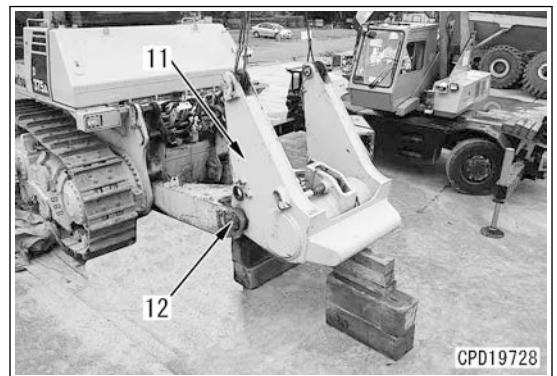

## REMOVE AND INSTALL AIR CONDITIONER UNIT ASSEMBLY

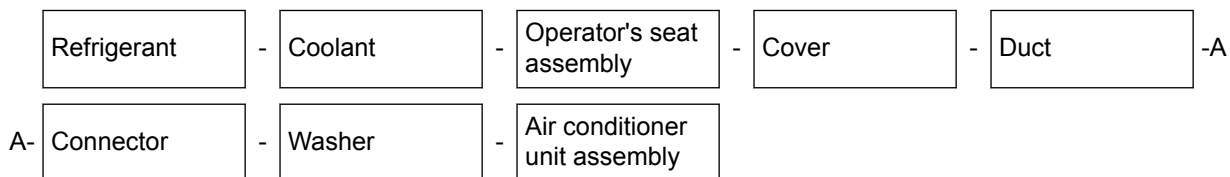

- ⚠ Place the machine on a level ground, and set the parking brake lever to LOCK position.
- ⚠ Lower the work equipment to the ground, and set the work equipment lock lever to LOCK position.
- ⚠ Turn the starting switch to OFF position to stop the engine.
- ⚠ Turn the battery disconnect switch to OFF position, and remove the key. (For details, see TESTING AND ADJUSTING, "HANDLE BATTERY DISCONNECT SWITCH".)
- ⚠ If you drain the radiator coolant when it is still hot, you may be scalded. Accordingly, wait for the coolant temperature to drop before draining.
- ⚠ Collect the air conditioner refrigerant (R134a) from the air conditioner circuit before disconnecting the air conditioner hose.
- ⚠ Ask a qualified person for collecting, adding, and filling operations of the refrigerant (air conditioner gas: R134a). (Only qualified persons can work.)
- ⚠ Never release the refrigerant (R134a) to the atmosphere.
- ⚠ If refrigerant gas (R134a) gets in your eyes, you may lose your sight. If it touches your skins, you may suffer from frostbite. Put on the protective eyeglasses, gloves, and working suits with long sleeves while you are collecting or filling with it.

### NOTICE

- Check the connector numbers and installed positions before disconnecting wirings and hoses, and write them down.
- When disconnecting the wires and hoses, take extreme care not to damage or deform the wires and hoses by the clips and clamps. If the wires or hoses may be damaged or deformed, remove the clips and clamps before starting the work.

## METHOD FOR REMOVING AIR CONDITIONER UNIT ASSEMBLY

### Collecting refrigerant

1. Collect the refrigerant (air conditioner gas: R134a) from the air conditioner circuit.  
Quantity of refrigerant to be collected: 1000±50 g

### Draining coolant

2. Drain the coolant.



### Operator's seat assembly

3. Remove the operator's seat assembly. See "REMOVE AND INSTALL OPERATOR'S SEAT ASSEMBLY".

## REMOVE AND INSTALL MACHINE MONITOR ASSEMBLY

- ⚠ Place the machine on a level ground, and set the parking brake lever to LOCK position.
- ⚠ Lower the work equipment to the ground, and set the work equipment lock lever to LOCK position.
- ⚠ Turn the starting switch to OFF position to stop the engine.
- ⚠ Turn the battery disconnect switch to OFF position, and remove the key. (For details, see TESTING AND ADJUSTING, "HANDLE BATTERY DISCONNECT SWITCH".)
- ⚠ Check the connector numbers and installed positions before disconnecting wirings and hoses, and write them down.
- ⚠ When disconnecting the wires and hoses, take extreme care not to damage or deform the wires and hoses by the clips and clamps. If the wires or hoses may be damaged or deformed, remove the clips and clamps before starting the work.

### METHOD FOR REMOVING MACHINE MONITOR ASSEMBLY

#### Monitor cover

1. Remove the bottom cover (1).
2. Remove the top cover (2).



#### Monitor assembly

3. Disconnect the wiring connectors FLSW (3), RLSW (4), and OPSW2 (5).

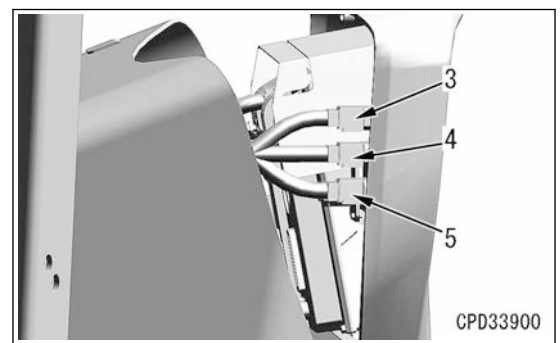

4. Disconnect the wiring connectors WLSW (6), OPSW1 (7), and RSW (8).

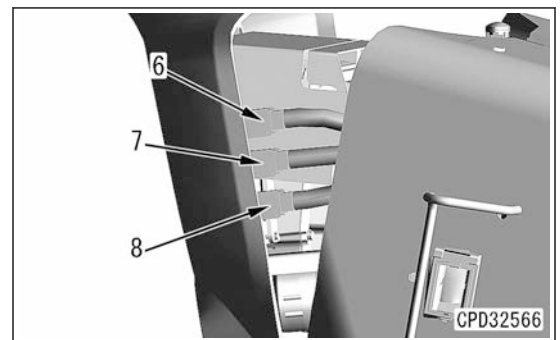

Abbreviation	Actual word spelled out	Purpose of use (major applicable machine (*1), or component/system)	Explanation
ICT	Information and Communication Technology	Communication and electronic control	A general term for the engineering and its socially applied technology of information processing and communication.
IMA	Inlet Metering Actuator	Engine	This is a valve that adjusts the fuel intake amount at the pump inlet in order to control the supply pump fuel discharged volume. (Same as IMV)
IMU	Inertial Measurement Unit	Engine	This is a device to detect the angle (or angular velocity) and acceleration of the 3 axes that control motions.
IMV	Inlet Metering Valve	Engine	This is a valve that adjusts the fuel intake amount at the pump inlet in order to control the supply pump combustion discharged volume. (Same as IMA)
KCCV	Komatsu Closed Crankcase Ventilation	Engine	This is a mechanism that burns the blowby gas again by separating oil from blowby gas and returning it to the intake side. It primarily consists of filters.
KCSF	Komatsu Catalyzed Soot Filter	Engine	This is a filter that captures soot in exhaust gas. It is built in to KDPF.
KDOC	Komatsu Diesel Oxidation Catalyst	Engine	This is a catalyst that is used for purifying exhaust gas. It is built in to KDPF or assembled with the muffler.
KDPF	Komatsu Diesel Particulate Filter	Engine	This is a component that is used to purify the exhaust gas. KDOC (catalyst) and KCSF (filter to capture soot) are built-in it. It is installed instead of the conventional muffler.
KTCS	Komatsu Traction Control System	Travel and brake  (HM)	This is a function that performs braking with the optimum force and recovers the driving force of the wheels by actuating the inter-axle differential lock when the wheels runs idle while the machine travels on the soft ground.
LCD	Liquid Crystal Display	Machine monitor	This is an image display equipment such as a monitor in which the liquid crystal elements are assembled.
LED	Light Emitting Diode	Electronic parts	This is a semiconductor element that emits light when the voltage is applied in forward direction.
LIN	Local Interconnect Network	Communication and electronic control	This is one of communication standards that are used in the network on the machine.
LS	Load Sensing	Hydraulic system	This is a function that detects differential pressure of pump, and controls discharged volume corresponding to load.
LVDS	Low Voltage Differential Signaling	Communication and electronic control	This is one of communication standards that are used in the network on the machine.
MAF	Mass Air Flow	Engine	This indicates engine intake air flow. This is not used independently but is used as combined with sensor. Mass air flow sensor can be called as MAF sensor.

# MAINTENANCE STANDARD OF LOCKUP CLUTCH ECMV

## NOTICE

Do not disassemble. It will require adjustment to obtain optimum performance.

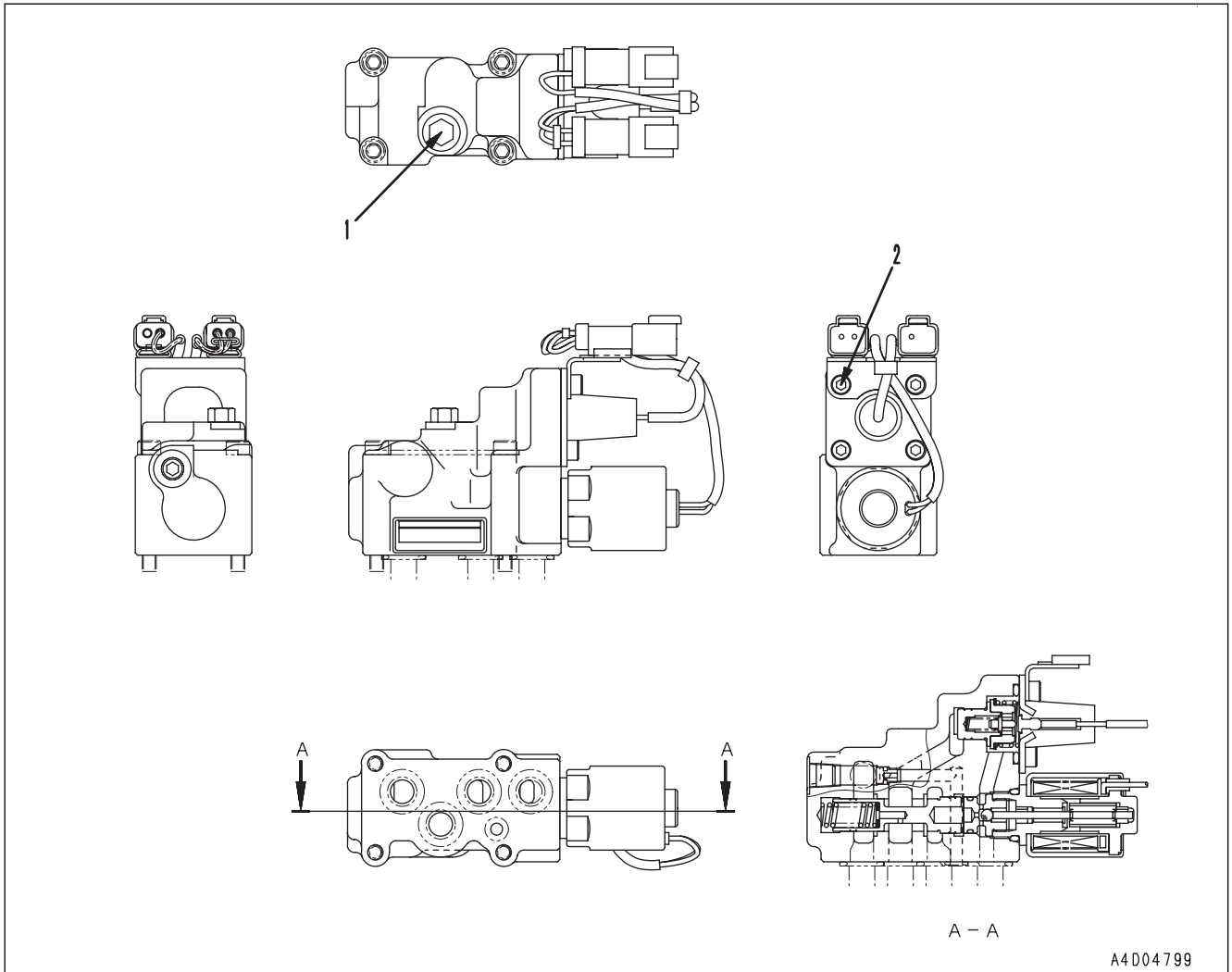

No.	Item	Judgment criteria	Remedy
1	Tightening torque of the bolt	9.8 to 12.74 Nm {1 to 1.8 kgfm}	Re-tighten
2	Tightening torque of the bolt	4.9 to 6.9 Nm {0.5 to 0.7 kgfm}	

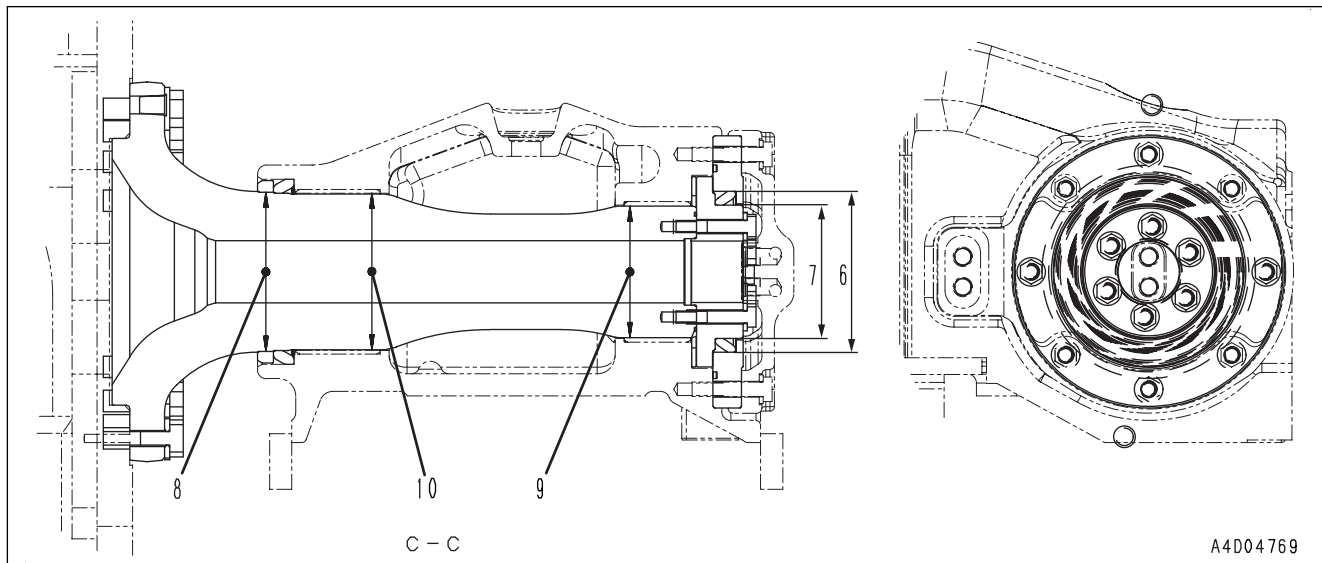

Unit:mm

No.	Item	Judgment criteria				Remedy	
		Standard dimensions	Tolerance		Standard interference		Allowable interference
Shaft	Hole		Standard clearance	Allowable clearance			
6	Interference of thrust washer and seal	230	+0.213	-0.180	0.278 to 0.439	-	Replace
			+0.098	-0.226			
			7	Interference between thrust washer and seal			
8	Interference between pivot shaft and seal	213	+0.096	-0.115	0.165 to 0.283	-	
9	Clearance between pivot shaft and bushing	175	-0.145	+0.097	0.174 to 0.305	1.0	Replace the bushing
			-0.208	+0.029			
10	Clearance between pivot shaft and bushing	210	-0.170	+0.072	0.170 to 0.314	1.0	
			-0.242	0			

**MAINTENANCE STANDARD OF QUICK DROP VALVE**

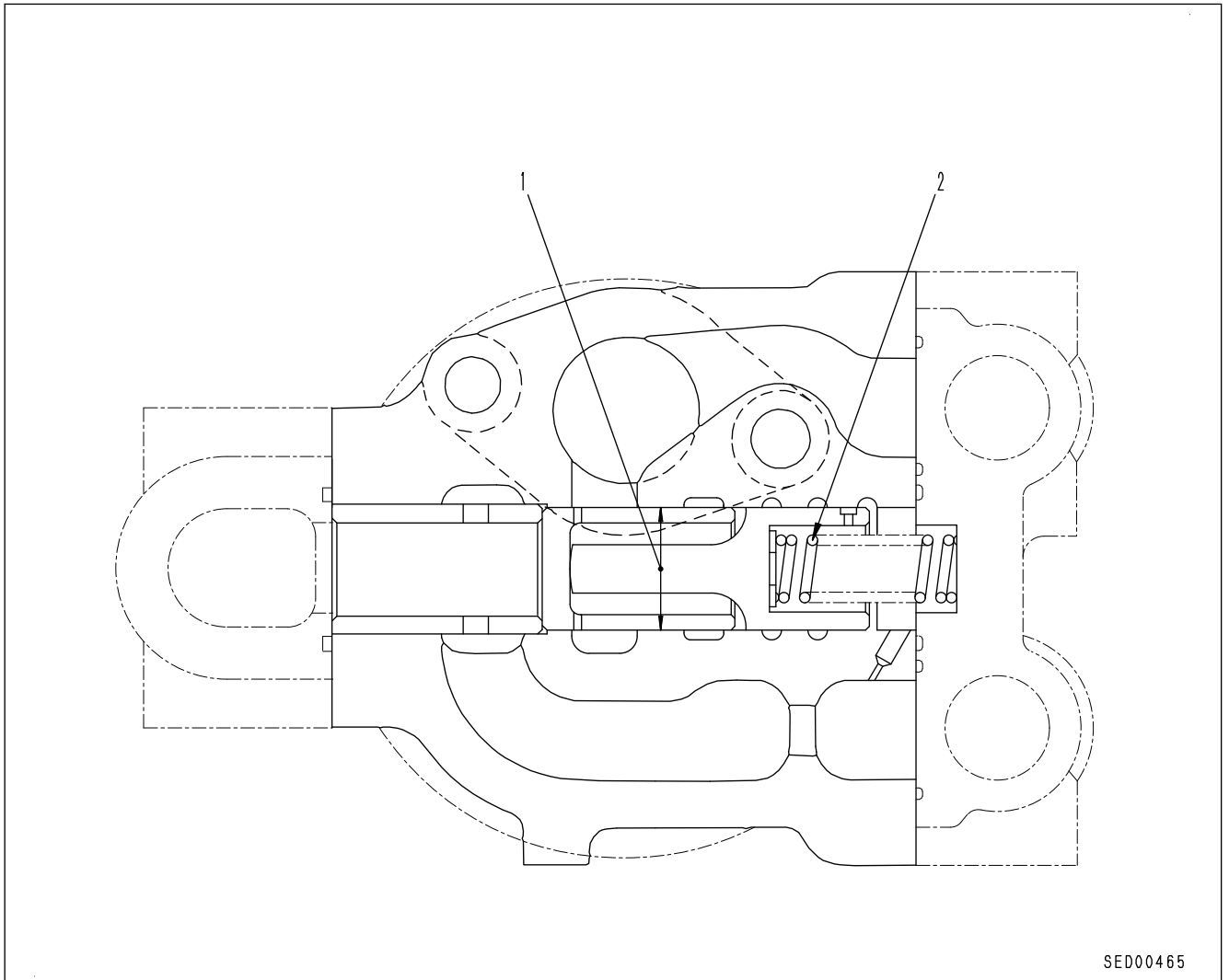

Unitmm

No.	Item	Judgment criteria				Remedy	
		Standard dimensions	Tolerance		Standard clearance		Allowable clearance
	Shaft		Hole				
1	Clearance between spool and valve body	38.0	-0.011 -0.016	+0.010 0	0.011 to 0.026	0.03	
2	Valve spring	Standard dimensions			Repair limit		Replace
		Free length x outside diameter	Installed height	Load at installed height	Free height	Load at installed height	
		27.9 x 6.5	22.5	14.7 N {1.5 kg}	-	11.8 N {1.2 kg}	

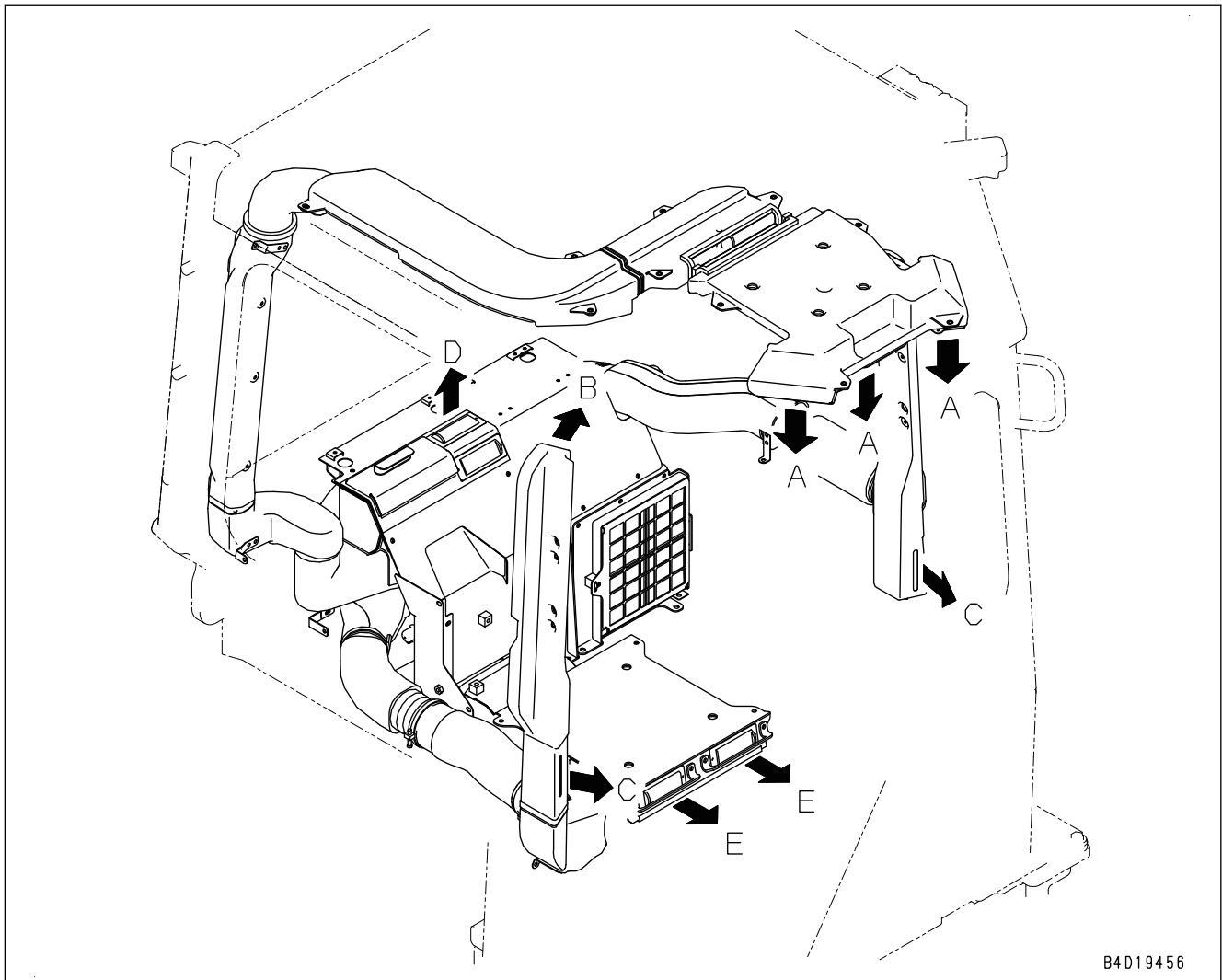

A: Front window and door window defroster vents

B: Face level air vents

C: Center air vents

D: Defroster vents

E: Recirculation air inlet

Check the connectors FDL, FD2, and FD3.

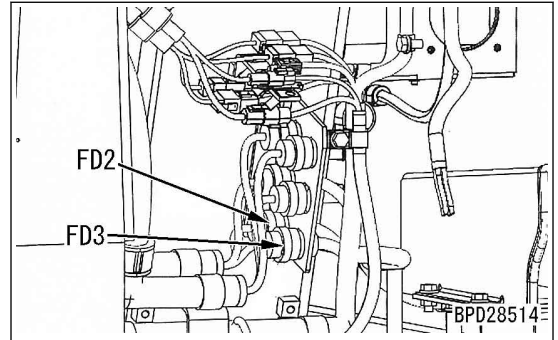
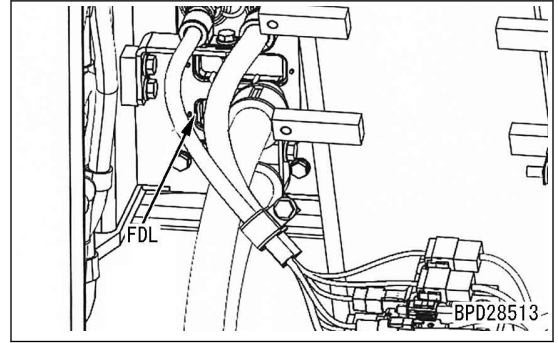

#### NOTICE

Waterproof seal is attached to the fitting surface of connectors FDL. Seals shown in the figure need to be prepared beforehand when disconnecting the connectors. (The seal may get stretched or broken when being disconnected.)

#### REMARK

Slowly remove the connector FDL straight to check for any broken seal, peeling and attachment of foreign matter. If the seal is defective, replace it.

Connecting the connector FDL

1. Check that the seal is fitted to the plug.
2. Check that the key position is matched to the groove on receptacle side (it is not fitted reversely).
3. Fit the connector on plug side to the receptacle (because the seal is protruded), and engage it as checking the seal not to be rolled up.
4. Lightly tighten the hexagonal head bolt in the center of the connector 2 to 3 turns.
5. Connect the connector on plug side completely, and adjust the connector on plug side so that the clearance between the engaged receptacle and the connector on plug side is even by visual check from all direction.
6. Tighten the lock bolt to the specified torque.

 Hexagonal head bolt :  
2.8±0.3 Nm {0.28±0.03 kgfm}

#### NOTICE

Do not tighten it excessively. Otherwise it may break and lock will not work.

FDL, 70 pins

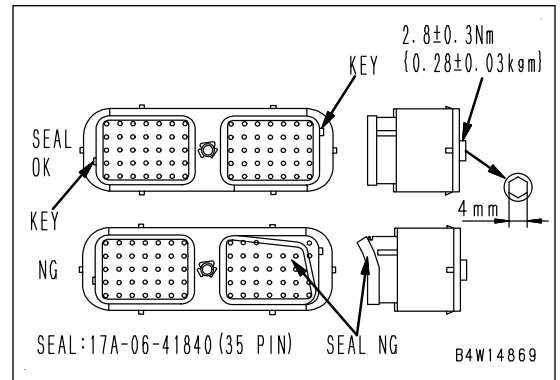

No.	Cause	Procedure, measuring location, criteria and remarks	
3	Defective wiring harness	If fuse is blown, replace it. 1. Turn starting switch to OFF position. 2. Turn battery disconnect switch OFF. 3. Disconnect connector AC02. 4. Turn battery disconnect switch ON. 5. Turn starting switch to ON position.	
		<table border="1"> <tr> <td>Voltage</td> <td>Between AC02 (female) (4) (brown) and (1) (black)</td> <td>20 to 30 V</td> </tr> </table>	Voltage
Voltage	Between AC02 (female) (4) (brown) and (1) (black)	20 to 30 V	
4	Open circuit in wiring harness	1. Turn starting switch to OFF position. 2. Turn battery disconnect switch OFF. 3. Disconnect connector AC02. 4. Remove fuse No. 9 of fuse box F01.	
		<table border="1"> <tr> <td>Resistance</td> <td>Between AC02 (female) (4) (brown) and F01-9.</td> <td>Max. 1 Ω</td> </tr> </table>	Resistance
Resistance	Between AC02 (female) (4) (brown) and F01-9.	Max. 1 Ω	
5	Ground fault in wiring harness (contact with ground circuit)	If fuse is blown again in above test, perform following procedure. 1. Turn starting switch to OFF position. 2. Turn battery disconnect switch OFF. 3. Disconnect connector AC02. 4. Remove fuse No. 9 from fuse box F01.	
		<table border="1"> <tr> <td>Resistance</td> <td>Between ground and AC02 (female) (4) (brown) or F01-9.</td> <td>Min. 1 MΩ</td> </tr> </table>	Resistance
Resistance	Between ground and AC02 (female) (4) (brown) or F01-9.	Min. 1 MΩ	
6	Defective air conditioner controller	If failure code is still displayed after above checks, air conditioner controller is defective. (In case of an internal defect, troubleshooting is impossible as an assembly Replace whole assembly.)	
7	Defective air conditioner unit	If failure code is still displayed after above checks, air conditioner unit may be defective. (In case of an internal defect, troubleshooting is impossible as an assembly Replace whole assembly.)	
8	Defective machine monitor	If no failure is found by above checks, machine monitor is defective. (Since this is an internal defect, troubleshooting cannot be performed.)	

**Circuit diagram related to air conditioner power supply**

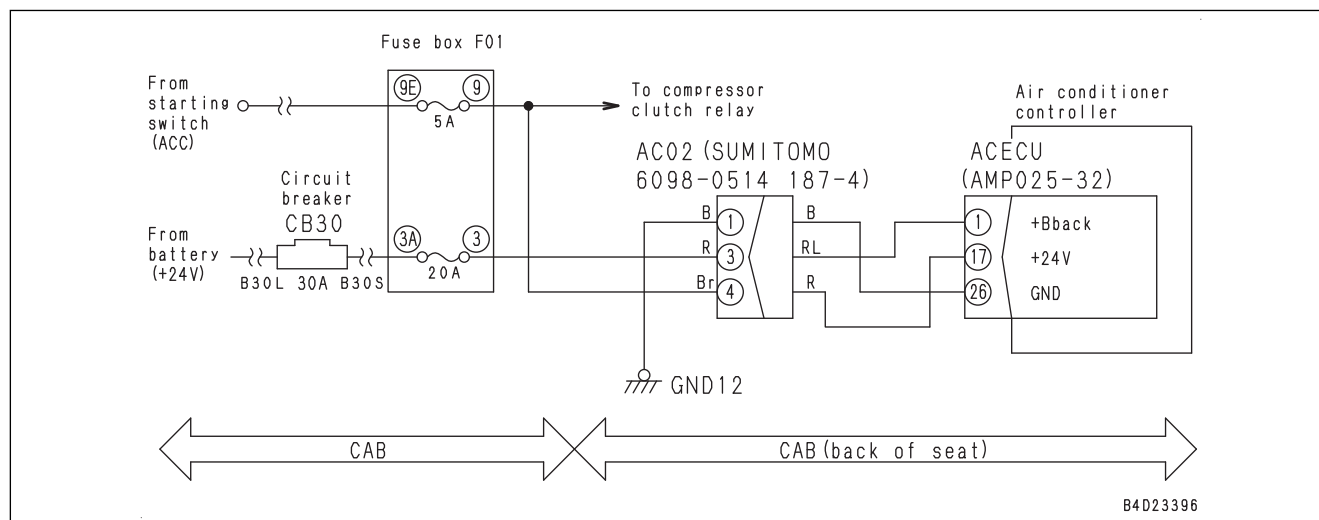

CLICK HERE TO **DOWNLOAD** THE COMPLETE MANUAL

- Thank you very much for reading the preview of the manual.
- You can download the complete manual from: [www.heydownloads.com](http://www.heydownloads.com) by clicking the link below



- Please note: If there is no response to CLICKING the link, please download this PDF first and then click on it.

CLICK HERE TO **DOWNLOAD** THE COMPLETE MANUAL