

SHOP MANUAL

KOMATSU

D20A,P,S,Q-6

D21A,P,S,Q-6

MACHINE MODEL	SERIAL No.	MACHINE MODEL	SERIAL No.
D20A-6	60001 and up	D21A-6	60001 and up
D20P-6	60001 and up	D21E-6	60001 and up
D20P-6A	60001 and up	D21P-6	60001 and up
D20PL-6	60001 and up	D21P-6A	60001 and up
D20PLL-6	60001 and up	D21P-6B	60001 and up
D20S-6	60001 and up	D21PL-6	60001 and up
D20Q-6	60001 and up	D21S-6	60001 and up
		D21S-6A	60001 and up
		D21Q-6	60001 and up

- This shop manual may contain attachments and optional equipment that are not available in your area. Please consult your local Komatsu distributor for those items you may require. Materials and specifications are subject to change without notice.
- D20, 21-6 mount the 4D95S-W-1 engine. For details of the engine, see the 95 Series Engine Shop Manual.

CLICK HERE TO **DOWNLOAD** THE COMPLETE MANUAL

- Thank you very much for reading the preview of the manual.
- You can download the complete manual from: www.heydownloads.com by clicking the link below



- Please note: If there is no response to CLICKING the link, please download this PDF first and then click on it.

CLICK HERE TO **DOWNLOAD** THE COMPLETE MANUAL

Unit: kg

Machine Model	D20A-6	D20P-6	D20P-6A	D20PL-6	D20PLL-6
Serial No.	60001 and up	60001 and up	60001 and up	60001 and up	60001 and up
Power angle and tiltdozzer assembly	385		412		
• Blade	172	—	195	—	—
• U-frame	146		146		
Straight tiltdozzer assembly		345		379	420
• Blade		173		195	212
• Straight frame (each side)	—	44	—	44	46
• Blade tilt cylinder assembly		13		13	13
• Tilt brace		6		6	6
Radiator guard	31	98	31	98	98
Engine underguard	12	12	12	12	12
Transmission underguard	16	16	16	16	16
Hood	18	18	18	18	18
Loader frame	82	70	82	70	70
Operator's seat assembly	21	21	21	21	21
Canopy assembly	35	35	35	35	35
	(60)	(60)	(60)	(60)	(60)

- ★ (60): D20A-6 Serial No. 61022 and up
D20P-6 Serial No. 60873 and up
D20P-6A Serial No. 61109 and up
D20PL-6 Serial No. 60145 and up
D20PLL-6 Serial No. 60100 and up

ADJUSTING VALVE CLEARANCE

Special tool

	Part Number	Part Name	Q'ty
A	795-125-1370	Feeler gauge	1

- ★ Adjust clearance between valve stem and rocker arm as follows.

Unit: mm

	Intake valve	Exhaust valve
At cold	0.35	0.5

1. Remove the cylinder head cover.
2. Rotate the crankshaft in the normal direction. While watching the movement of the intake valve of the No. 4 cylinder, bring the No. 1 cylinder into the top dead center position of the compression stroke and align the "1.4 TOP" mark on crankshaft pulley (1) with pointer (2).
3. When No. 1 cylinder is top dead center of compression stroke, adjust the valve clearance for valves marked ● in the valve arrangement chart.
4. To adjust the valve clearance, loosen locknut (6) on adjustment screw (5), insert feeler gauge A corresponding to the specified clearance between valve stem (4) and rocker arm (3), and adjust the clearance with the adjustment screw until the thickness gauge can slide lightly.
5. Rotate the crankshaft in the normal direction by one revolution and adjust the valve clearance for the remaining valves marked ○.
6. After the clearance is properly adjusted, tighten the locknut to secure the adjustment screw.

 Locknut: 3.15 ± 0.35 kgm

- ★ Intake and exhaust valve clearances may be adjusted for each cylinder in the firing order by rotating the crankshaft 180° at a time in the normal direction.
- ★ Firing order is 1 – 2 – 4 – 3.
- ★ After tightening locknut, check valve clearance again.

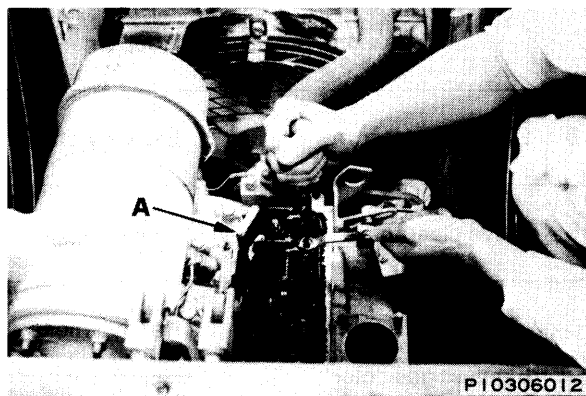
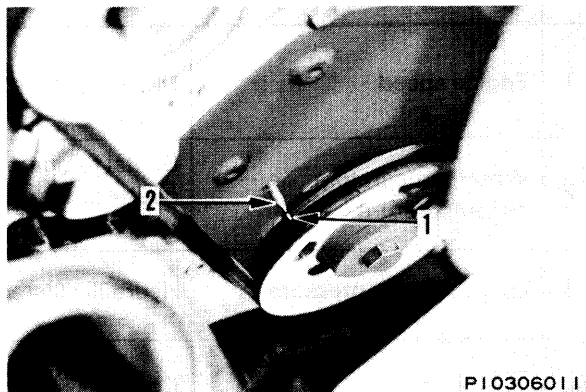

Cylinder No.	1	2	3	4
Intake valve	●	○	●	○
Exhaust valve	●	●	○	○

Front 

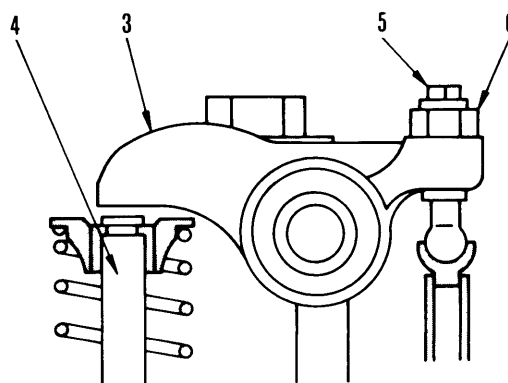

21KF101

P1

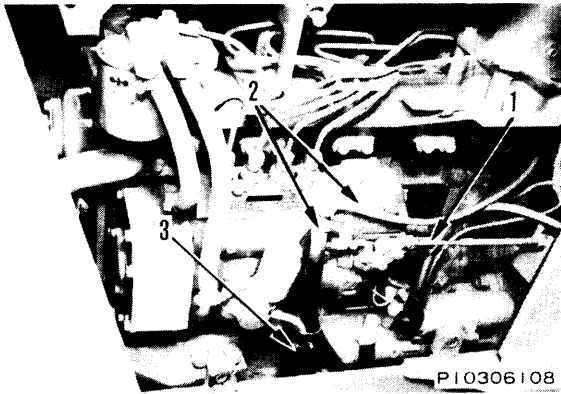

P4

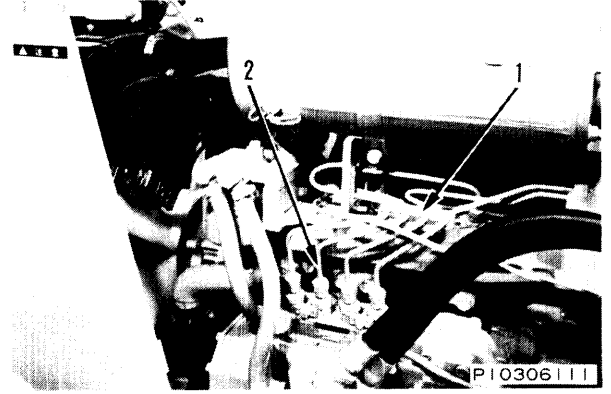

P2

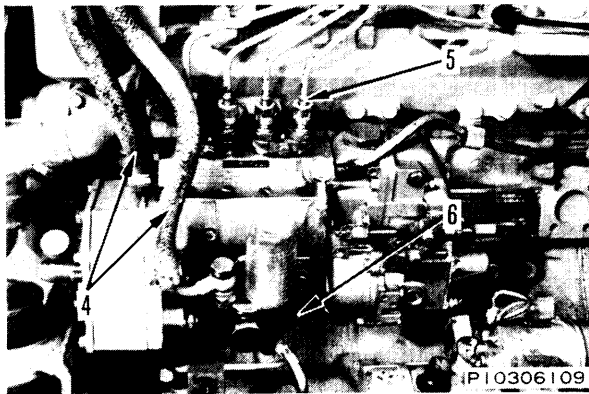

P5

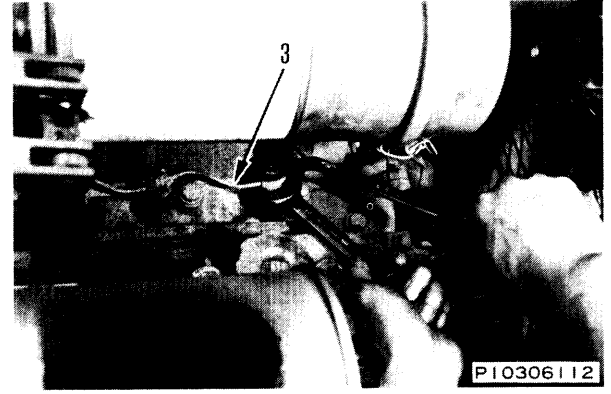

P3

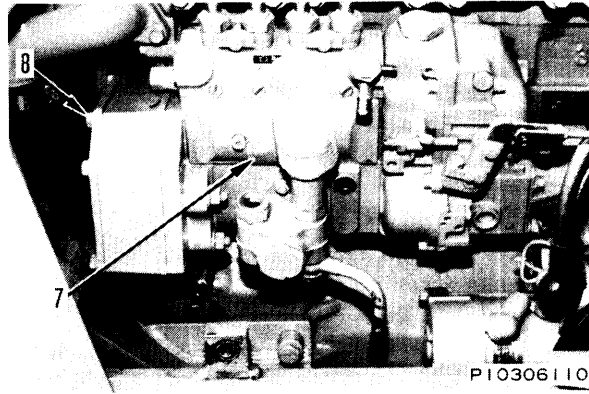

P6

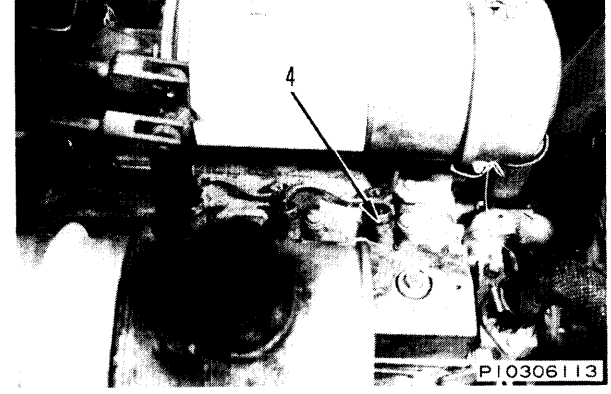

P1

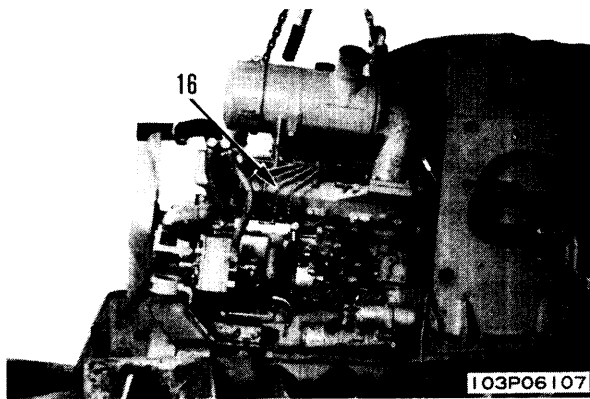

103P06107

P5

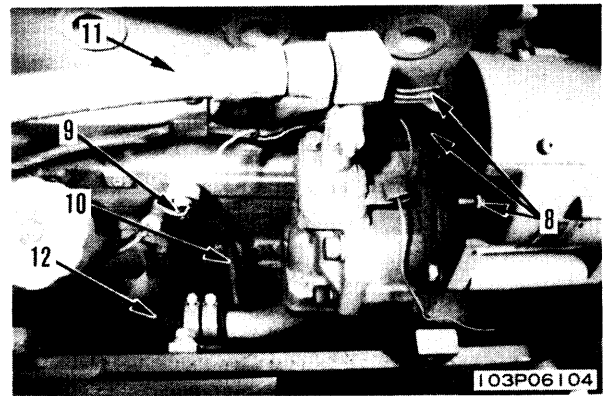

103P06104

P2

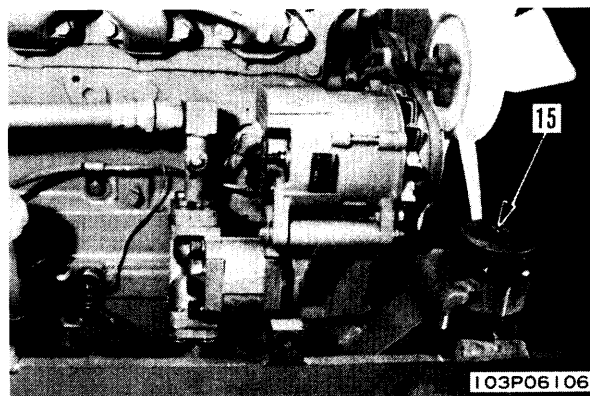

103P06106

P6

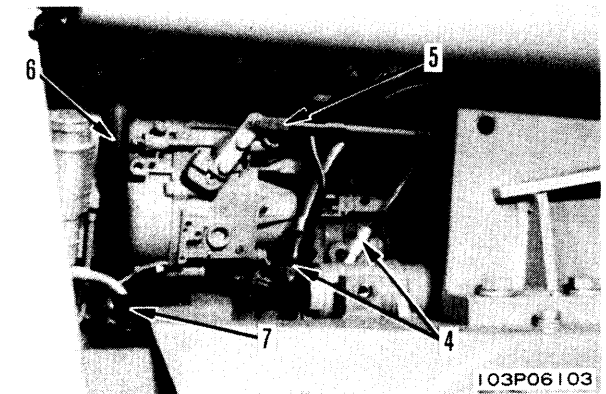

103P06103

P3



103P06105

P7

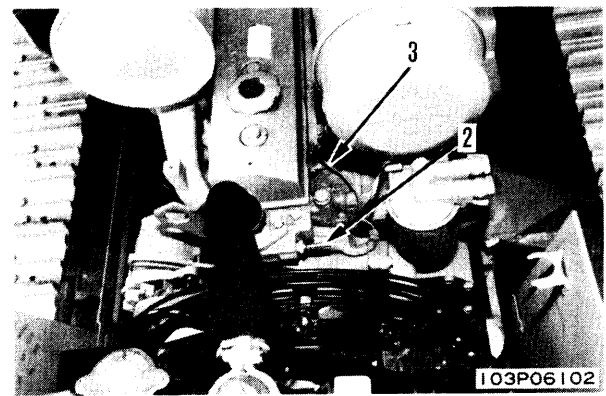

103P06102

P4

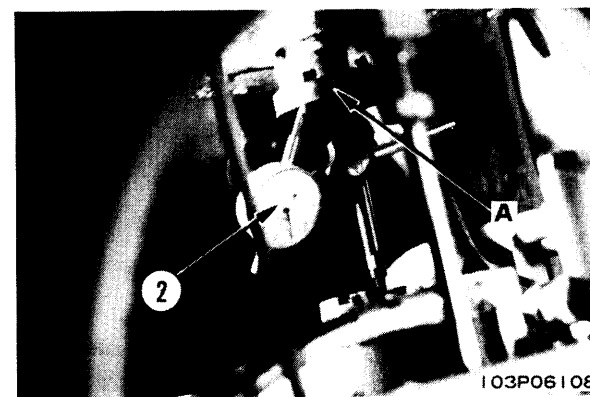

103P06108

P8

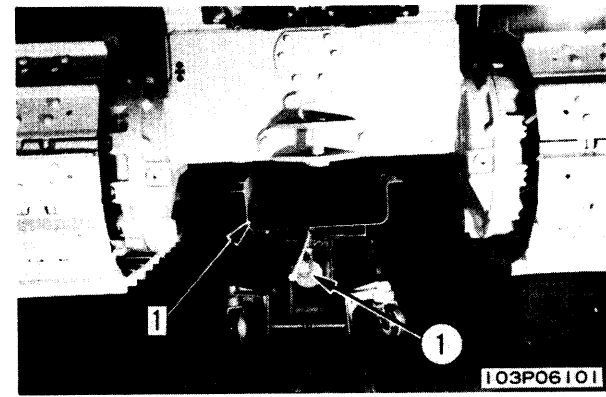

103P06101

POWER TRAIN HYDRAULIC SYSTEM

D21E-6, D21P-6B, D21S-6A

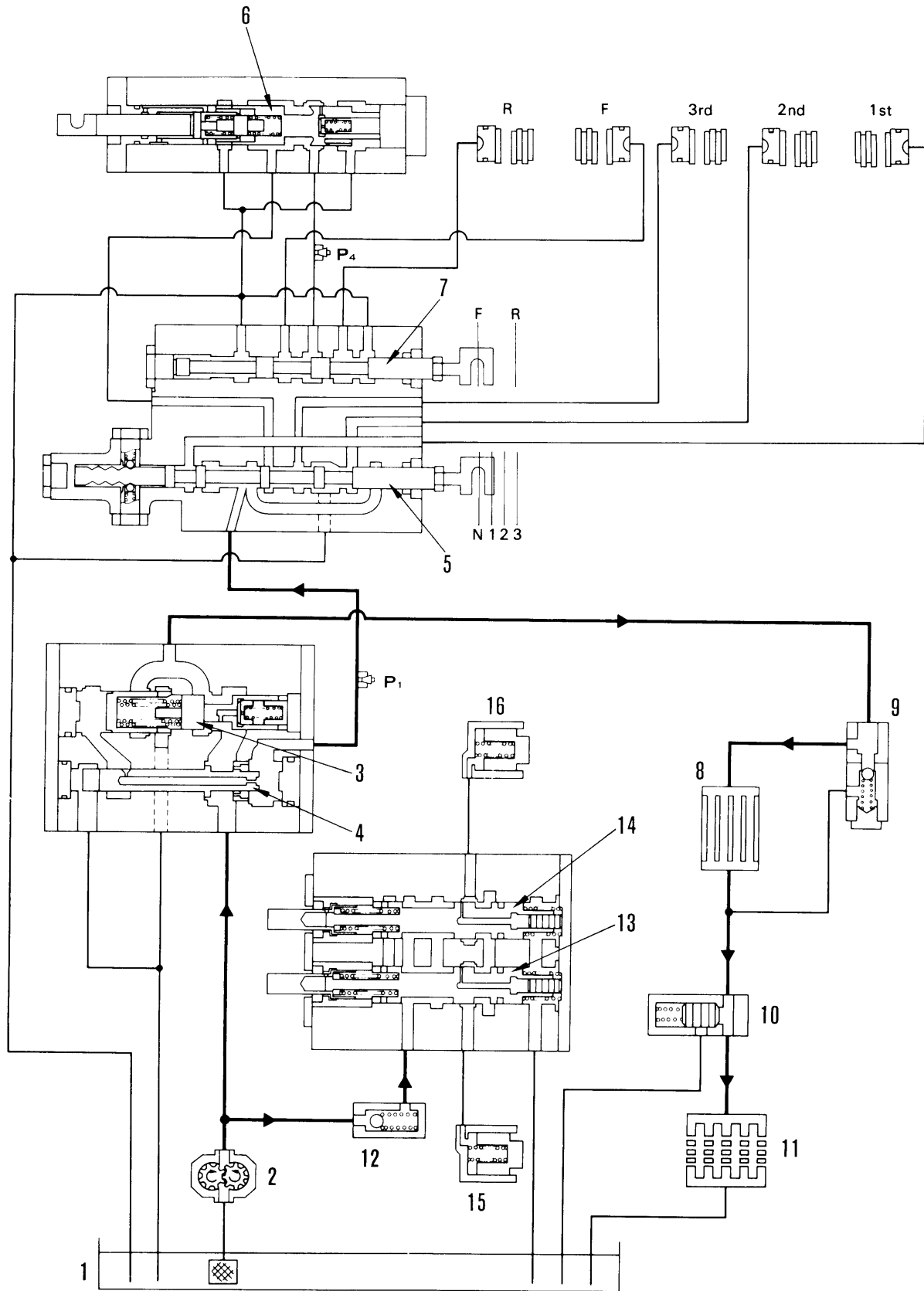

F10406002

POWER TRAIN

In neutral

Main shaft gear (B) is constantly in mesh with intermediate shaft gear (H). As main shaft (8) is rotated by the engine, intermediate shaft (10) is rotated in the opposite direction to the main shaft. However, counter shaft (9) does not rotate, because the counter shaft gear is not in mesh with those on the main shaft and intermediate shaft.

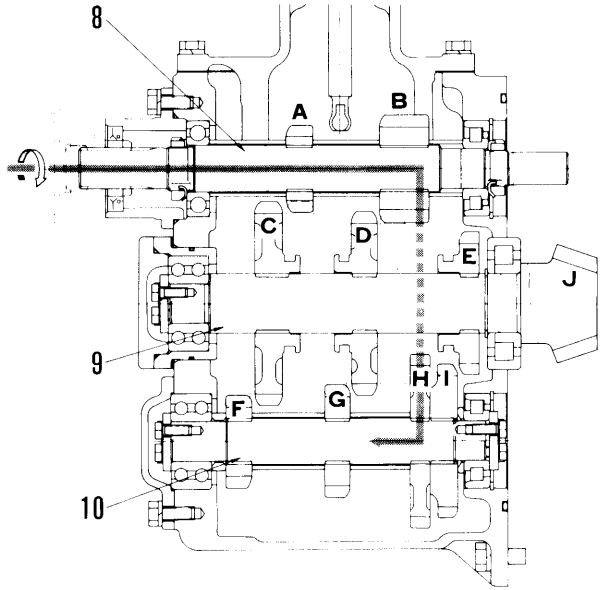

F10306011

Forward-1st speed [B → H → F → C → J]

Place the gear shift lever in "F-1" at the operator's compartment:

Slide countershaft gear (C) forward with a shifting fork to get into mesh with intermediate shaft gear (F).

When the main shaft is rotated by power from the engine, the intermediate shaft rotates in the opposite direction to the main shaft. Then, intermediate shaft gear (F) rotates countershaft gear (C) in the same direction as the main shaft, and transmits power to the bevel pinion (J).

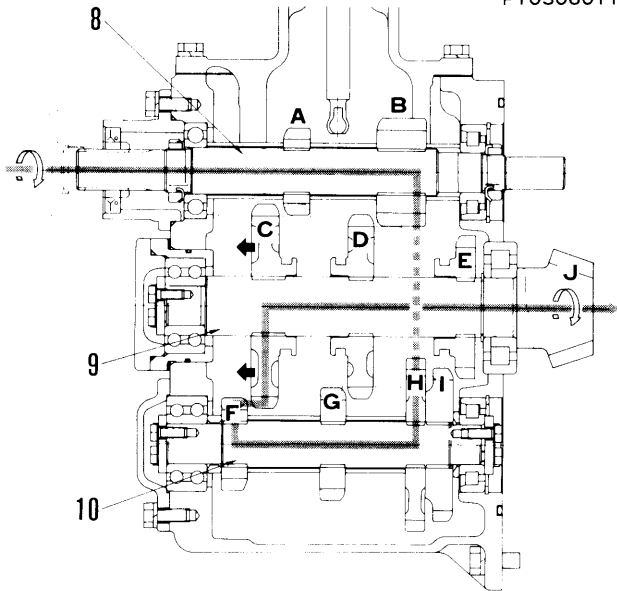

F10306012

Reverse-1st speed [A → C → J]

Place the gear shift lever in "R-1" at the operator's compartment:

Slide countershaft gear (C) rearward with a shifting fork to get into mesh with main shaft gear (A).

When the main shaft is rotated by power from the engine, the countershaft rotates in the opposite direction to the main shaft, and transmits power to the bevel pinion (J).

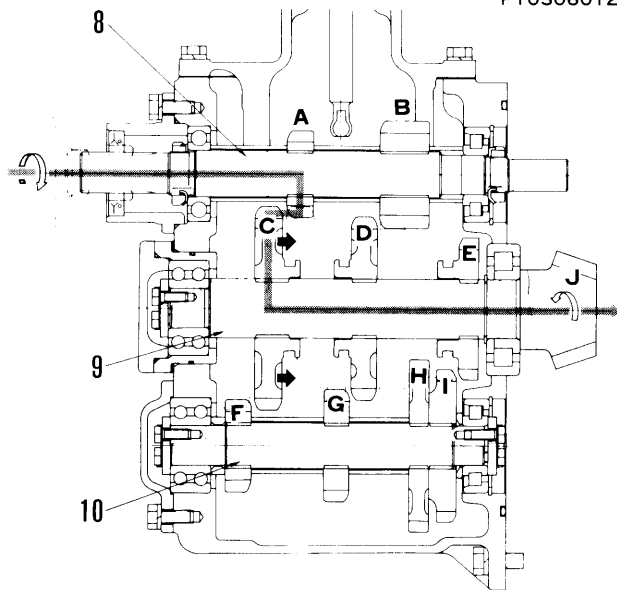

F10306013

HYDROSHIFT TRANSMISSION

D21E-6
D21P-6B
D21S-6A

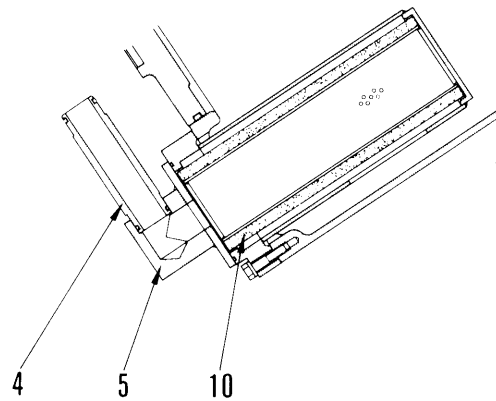
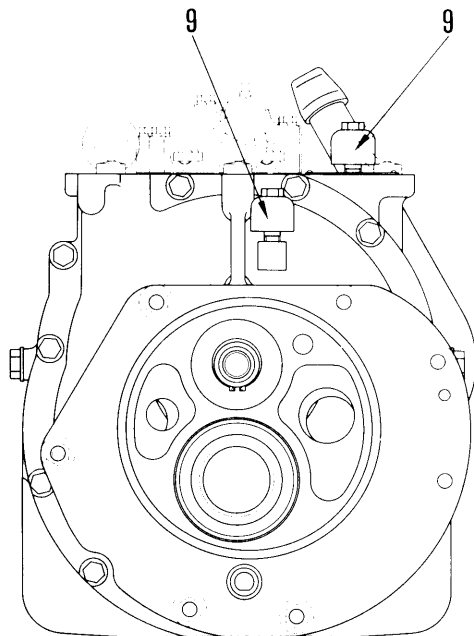
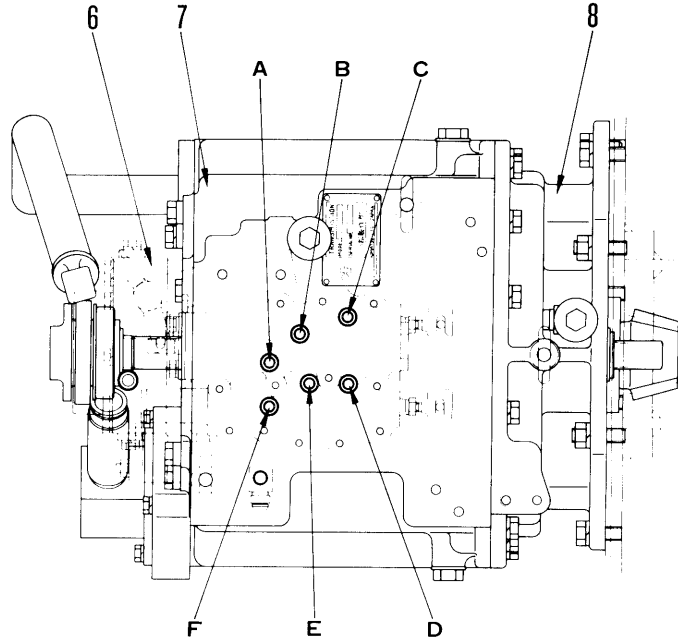
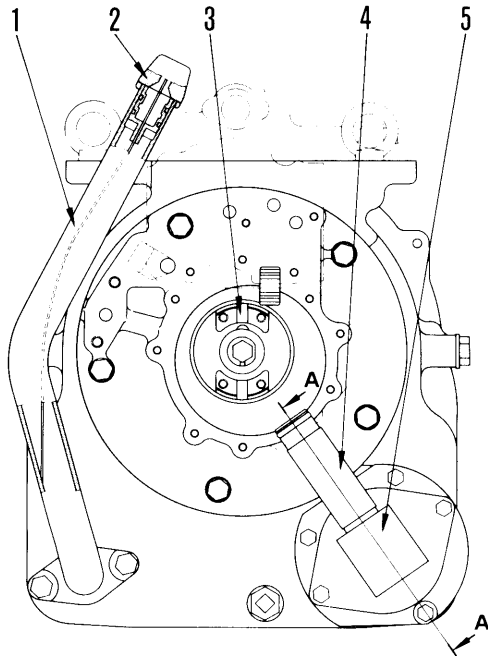

Section A-A

F10406005

- A. To 1st speed clutch
- B. To forward clutch
- C. To reverse clutch
- D. To 2nd speed clutch
- E. To 3rd speed clutch
- F. From modulation valve

- 1. Oil filler
- 2. Oil level gauge
- 3. Input coupling
- 4. Sleeve
- 5. Cover
- 6. Transmission pump
- 7. Transmission case
- 8. Transfer case
- 9. Breather
- 10. Oil strainer

HYDROSHIFT TRANSMISSION HYDRAULIC CIRCUIT DIAGRAM

D21A, P, S, Q-6
D21P-6A

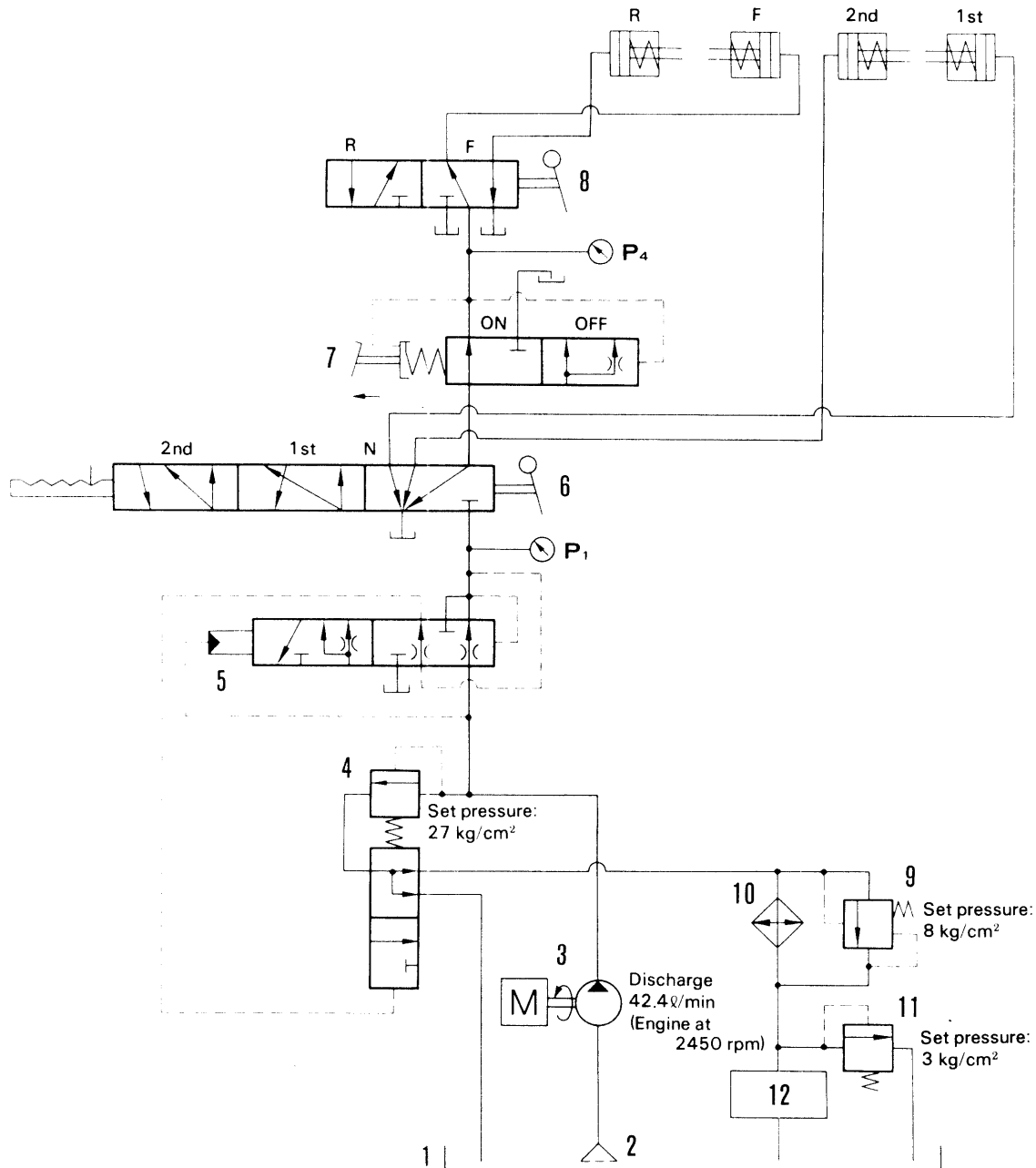

F10306025

OUTLINE

- The oil in transmission case (1) is sucked by transmission pump (3) through strainer (2), and is sent to modulating valve (4) and quick return valve (5).
- The modulating valve and quick return valve act together, and regulates the oil pressure in the circuit at 27 kg/cm². The oil flows through to the oil cooler and transmission case.
- The oil flowing to the quick return valve enters speed valve (6), inching valve (7) and F-R valve (8).
- The oil cooler bypass valve (9) is installed on transmission case.
- The transmission lubrication relief valve (11) is built into the transmission.

INCHING VALVE

OUTLINE

- The inching valve is in the circuit between the speed valve and F-R valve. The amount that the inching pedal is operated adjusts the amount of oil (oil pressure) sent from the speed valve to the F-R valve. This changes the contact force of the FORWARD or REVERSE clutches to partially disengage the clutches and allow fine control of the travel speed; or it completely disengages the clutches to make it possible to stop the machine.

OPERATION

1. Inching pedal not operated

Spool (16) is interconnected with the inching pedal, so when the inching pedal is not being operated, it is at the end of its stroke on the right. As a result, valve (10) is pushed to the right by sleeve (14) together with the spool.

The oil sent under pressure from the pump passes through the modulating valve and speed valve and enters ports **A** and **B**. It then passes through the F-R valve and flows to the FORWARD or REVERSE clutch piston port.

The oil passing through orifice **a** and entering chamber **C** becomes the force trying to move valve (10) to the left because of the reaction pushing piston (7).

However, valve (10) is in contact with sleeve (14), so it cannot move to the left. Therefore, passage **b** between port **A** and **B** is kept fully open.

As a result, the oil from the speed valve gradually increases in pressure because of the action of the modulating valve. It enters clutch piston port and fully engages the clutch.

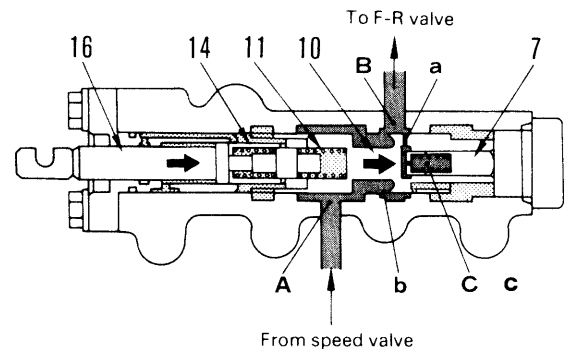

F10306033

STEERING HYDRAULIC SYSTEM

D21-6

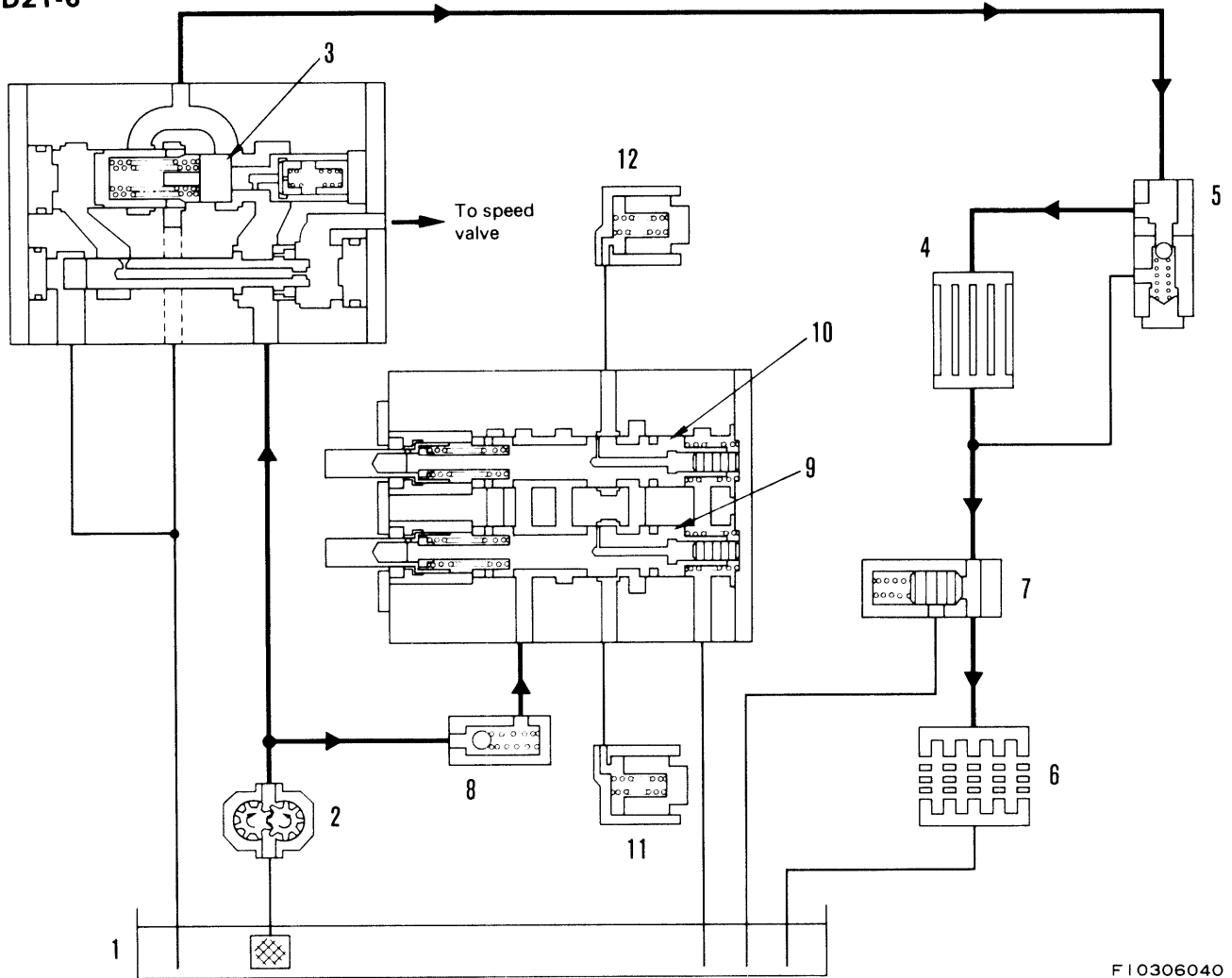

F 10306040

STEERING HYDRAULIC CIRCUIT DIAGRAM

D21-6

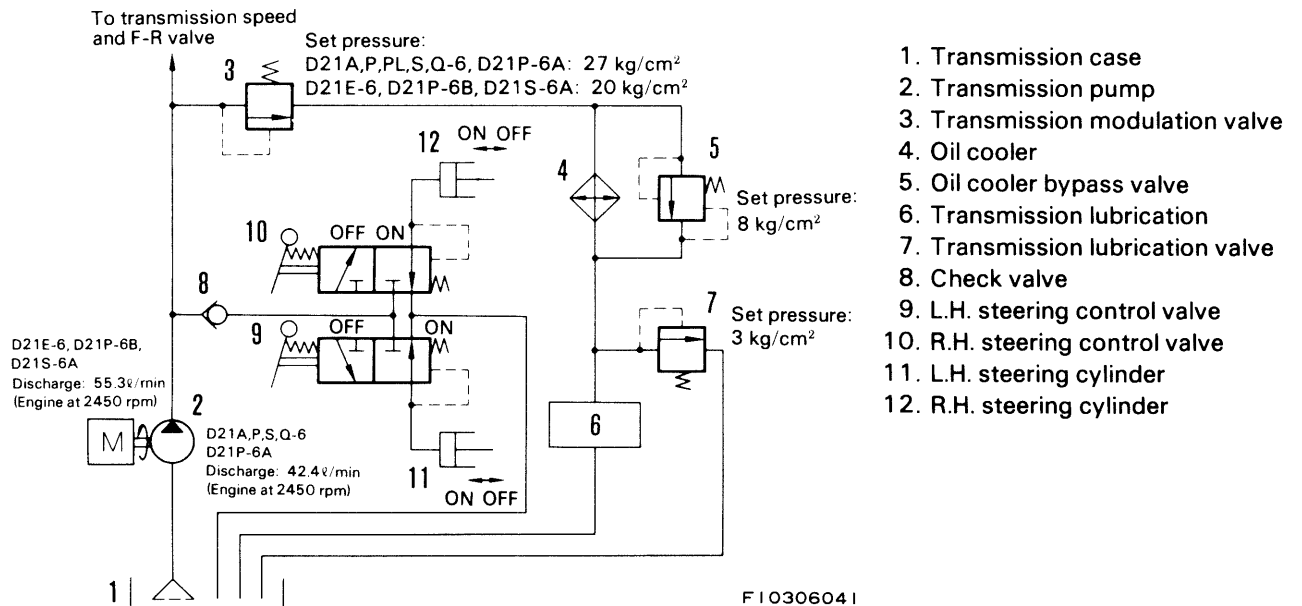

F 10306041

POWER TRAIN

22 TESTING AND ADJUSTING



Standard for testing and adjusting	22- 2
Testing and adjusting tool list	22- 4
Measurng oil pressure	22- 5
Measuring oil temperature	22- 7
Testing travel	22- 8
Measuring operating force	22-10
Adjusting fuel control lever	22-12
Adjusting main clutch control linkage	22-13
Adjusting inching control linkage	22-14
Adjusting gear shift lever control linkage	22-16
Adjusting steering control linkage	22-17
Adjusting brake control linkage	22-18
Troubleshooting	22-19



When carrying out testing, adjusting or troubleshooting, stop the machine on level ground, install the safety pins and block the tracks.



When working in groups, use agreed signals and do not allow unauthorized persons near the machine.



When checking the water level in the radiator, wait for the water to cool. Do not remove the radiator cap while the water is hot. Boiling water may spurt out.



Be careful not to get caught in rotating parts.

5. Measuring operating force of inching pedal (D21-6)

- 1) Run the engine at low idling, and put push-pull scale ① in contact with the center of the pedal.
- 2) Push the pedal fully, and measure the operating force.

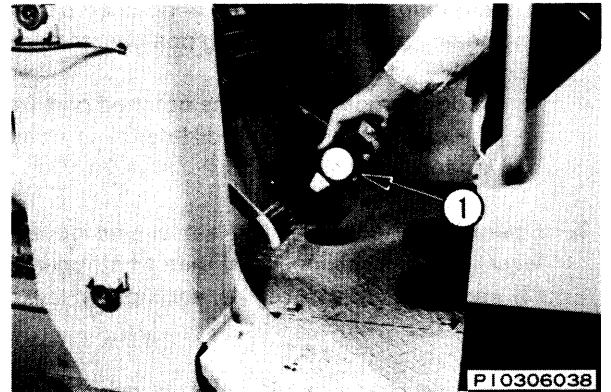

6. Measuring operating force of steering lever

- 1) Stop the engine, and hook push-pull scale ① on the center of the lever knob.
- 2) Pull the lever fully, and measure the operating force.

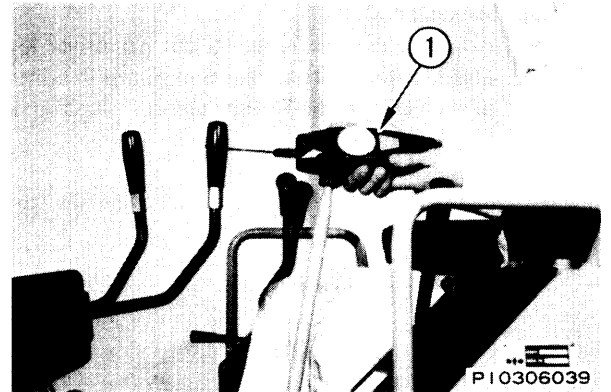

7. Measuring operating force of brake pedal

- 1) Run the engine at low idling, and put push-pull scale ① in contact with the center of the pedal.
- 2) Push the pedal fully, and measure the operating force.



**2. Drawbar-pull is small or travel speed is low.
(Normal power cannot be obtained and travel speed does not increase)**

Ask the operator the following questions.

- Did you operate this machine from ago?
- Why were you aware of the insufficient performance?
 - As compared with before
 - The machine is considered improper
 - As compared with other model (large model)
 - The machine is considered normal

Check before troubleshooting

- Is oil quantity of transmission case and/or bevel gear case normal?
- Does the oil leak from piping and from between case and valve?
- Is the steering brake locked?
- Is the tension of track normal?

No.	Problems	Remedy	Cause								
			Case to pump			Trans- mission control valve	Transmission				Other unit
			a	b	c	d	e	f	g	h	i
		C	△ X	X	△ X	X	X	X	X		
1	Unusual noise is heard from transmission pump when oil temperature is low.		○								
2	The drawbar pull and travel speed becomes normal when the gear shift lever is operated to a certain speed position.					○	○	○			
3	The transmission modulating relief pressure does not rise for any speed position.		○	○	○						
4	The transmission modulating relief pressure is only normal when placing the gear shift lever in a certain speed position.					○		○			
5	The transmission modulating relief pressure is not stable.		○								
6	Engine rotation speed is low.									○	

- ★ If engine is defective, check the cause using the ENGINE TROUBLESHOOTING TABLE.
- ★ If all other possible causes have been eliminated, a possible cause is damage of the brake and steering clutch.

Troubleshooting tools	Thermistor temperature gauge	Hydraulic tester
	Tachometer	

The following symbols are used to indicate the action to be taken when a cause of failure is located.
 X: Replace △: Repair
 A: Adjust C: Clean

DISASSEMBLY OF COVER ASSEMBLY

- 1.** Remove springs (1). (See P1)
- 2.** Remove mounting bolts (2), then remove ring gear (3). (See P1, P2)

DISASSEMBLY OF TRANSMISSION ASSEMBLY

D20-6

Special tools

	Part No.	Part Name	Q'ty
A	790-501-5000	Unit repair stand	1
A ₁	790-901-3120	• Bracket	1
B	791-317-1320	Nut wrench	1
C	791-317-1310	Nut wrench	1

Preparatory work

- Set transmission assembly (1) on tool A. (See P1)



Transmission assembly: 70 kg

1. Remove rod connecting bracket (2) and breather cover (3). (See P1)
2. Remove shifting cover assembly (4). (See P2)
3. Remove coupling (5). (See P3)
4. Remove oil seal cage (6). (See P3)
5. Pull out oil seal (7) from cage. (See P4)
6. Raise tab of lock plate, then using tool B, remove nut (8) at input end of main shaft. (See P5, P6)
 - ★ When loosening the nut, keep the transmission gear meshed.
7. Raise tab of lock plate, then using tool C, remove nut (9) at output end of main shaft. (See P7, P8)
 - ★ When loosening the nut, keep the transmission gear meshed.
8. Pull main shaft out a small distance towards input end, put a copper bar in contact with gear, then remove bearing (10). (See P9)
 - ★ When removing the bearing, support one end of the main shaft and remove, taking care not to let the bearing hit the other gear and damage it.
9. Pull out main shaft slowly, and remove bearing (10), collar (11), gear (12), collar (13), gear (14), and collar (15) in order. (See P10)
10. Pull out bearing (17) from main shaft (16). (See F1)

18. Press fit bearing (17) to main shaft (16). (See F1)

19. Turn over transmission case, assemble collar (11), gear (12), collar (13), gear (14), and collar (15) to main shaft in order shown in Fig. F1, then tap main shaft with a plastic hammer to press fit bearing at output end to case. (See F1, P1)

20. Fit nut (8) at input end of main shaft, then temporarily assemble oil seal cage (6). (See P2, P3)

- ★ Assemble the cage temporarily in order to press fit the bearing at the output end of the main shaft.

21. Turn over transmission case to put output end at top.

22. Using push tool ⑥ (inside diameter: 30 mm), press fit bearing (10). (See P4)

23. Using push tool ⑦ (outside diameter: 72 mm), press fit outer race (44) into snap ring mount groove. (See P5)

- ★ When press fitting the outer race, be careful that it is in the correct position and will not damage the bearing roller.

24. Install snap ring (43). (See P6)

25. Assemble lock plate, and using tool C, tighten nut (9) at output end of main shaft. (See P7, P8)

 Nut: 22.5 ± 7.5 kgm

- ★ Tighten the nut at the input and output ends of the main shaft at the same time to keep the relationship in adjustment of dimensions.
- ★ Bend the lock plate securely.

26. Remove temporarily assembled oil seal cage (6).

27. Using tool B, tighten nut (8) at input end of main shaft. (See P9, P10)

 Nut: 22.5 ± 7.5 kgm

- ★ Bend the lock plate securely.
- ★ Tighten the nut at the input and output ends of the main shaft at the same time to keep the relationship in adjustment of dimensions.

28. After tightening nuts, check that dimensions **a** and **b** between end face of transmission case and end face of main shaft are the standard. (See F2)

- ★ Dimension **a** at input end: 54 mm
Dimension **b** at output end: 46 mm
- ★ Check that the main shaft rotates freely.

INSTALLATION OF HYDROSHIFT TRANSMISSION ASSEMBLY

D21-6

1. Fit O-ring, put transmission assembly (20) on lift truck ④, then push under machine. (See P1)
2. Install eyebolts ③ (Thread dia. = 12 mm, Pitch = 1.75 mm) x 2, (Thread dia. = 10 mm, Pitch = 1.5 mm) x 1, raise slowly and set transmission assembly in position on steering case. (See P2)
3. Knock in dowel pin, and tighten 5 mounting bolts and 2 nuts, then install transmission assembly. (See P3)
4. Install universal joint assembly (19). (See P4)
5. Fit gasket and install oil filler (18). (See P5)
6. Assemble O-rings and connect tube (16) between modulating valve and cooler, and tube (17) between transmission case and cooler at the same time. (See P5)
7. Connect hose (15) between steering control valve and modulating valve. (See P6)
8. Connect hose (14) between steering control valve and transmission case. (See P6)
 - ★ Install the hose without twisting or interference.
9. Install battery wiring clamp (13). (See P6)
10. Connect inching cable (12) together with bracket to spool. (See P7)
11. Install spring (10). (See P7)
12. Adjust with locknut (11) so that there is no slack in inching cable. (See P7)
 - ★ After adjusting, tighten the locknut securely.
13. Depress inching pedal and check that dimension a of inching spool is within standard value. (See F1)
 - ★ Dimension a: 23.5 mm
 - ★ For details of adjustment, see 22 TESTING AND ADJUSTING.

29. Remove springs (50), then discs (51) and plates (52) in turn. (See P1, P2)

- ★ Keep the plates and discs stored in a vertical or horizontal position to prevent any deformation.

33. Remove ring gear (60). (See P9)

34. Remove guide pins (61). (See P10)

30. Remove plate (53), then remove discs (54) and plates (55) in turn. (See P3, P4)

35. Remove plate (62). (See P11)

31. Remove snap ring (56), then remove No. 3 sun gear (57). (See P5, P6)

36. Remove snap ring, then remove No. 4 sun gear (63). (See P12)

32. Remove snap ring (58), then remove ring gear (59). (See P7, P8)

37. Using puller ③, remove No. 4 carrier assembly (64). (See P13)

ASSEMBLY OF HYDROSHIFT TRANSMISSION ASSEMBLY (2 SPEED)

D21A,P,S,Q-6, D21P-6A

Special tools

	Part No.	Part Name	Q'ty
A	790-501-5000	Unit repair stand	1
A ₁	790-501-3120	• Bracket	1
B	799-301-1300	Air checker	1

ASSEMBLY OF TRANSFER ASSEMBLY

Preparatory work

- Set transfer case in tool A. (See P1)
1. Using push tool ⑩ (outside diameter: 100 mm), press fit bearing (10). (See P1)
 2. Using push tool ⑪ (outside diameter: 80 mm), press fit bearing (11). (See P2)
 3. Turn over transfer case to put output side at bottom.
 4. Assemble gear (9). (See P3)
 5. Knock in dowel pin, and install cover (8). (See P4)
 6. Using push tool ⑫ (outside diameter: 80 mm), press fit bearing (7) to cage. (See P5, P6)
 7. Assemble shim (6). (See P7)
 - ★ Standard shim thickness: 2.0 mm
 - ★ Types of shim: t = 1.0 mm, t = 0.3 mm, t = 0.2 mm
 - ★ Install the same thickness of shims as was removed during disassembly.
 8. Assemble bearing cage (5), and install plate (4). (See P8)

9. Using push tool ⑬ (inside diameter: 45 mm), press fit inner race (3) to pinion (2). (See P9, P10)

10. Turn over transfer case and put output side at top.

11. Assemble pinion (2), and using a copper bar, install. (See P11)

- ★ There is danger that the bearing at the cage end will be damaged when installing the pinion, so knock it in carefully.

12. Turn over transfer case, and install holder (1). (See P12)

 Mounting bolt: 11.5 ± 1.5 kgm

 Mounting bolt: Thread tightener (LT-2)

- ★ After installing the holder, check that the pinion rotates smoothly.

19. Install No. 2 and 3 pistons (49) and (48) to No. 2, 3 housing assembly (47). (See P1)

20. Install No. 2, 3 housing assembly (47). (See P2)
★ Check the direction of the sleeve mounting hole.
★ Hit the dowel pin area with a plastic hammer until there is no clearance between No. 4 housing and No. 2, 3 housing.

21. Install 2 snap rings (56). (See P3)

22. Install sun gear (57). (See P4)

23. Install snap ring (56). (See P5)

24. Set No. 2, 3 carrier assembly (44) in position. (See P6)

25. Using push tool ⑩ (inside diameter: 35 mm), press fit No. 2, 3 carrier assembly. (See P7)

26. Install snap ring (43) to shaft end. (See P8)

27. Install spring (46) and valve (45) in order. (See P9)
★ Free height of spring: 25.4 mm

28. Install ring gears (42) and (41). (See P10)

29. Install snap ring (40). (See P11)
★ After installing the snap ring, lift the ring gear and check the sound to confirm that the snap ring is fitted in the ring gear groove.
★ To check, push in the snap ring with a screwdriver, then lift up the ring gear. If it cannot be lifted, the snap ring is fitted securely in the ring gear groove.

30. Install plate (39). (See P12)

★ Assemble the plate so that the wide rib is on the guide pin side.

31. Install discs (38) and plates (37) in turn. (See P13)

★ Discs: 3
Plates: 3

32. Install plate (34). (See P14)

33. Install No. 1 ring gear (28). (See P15)

12. Install eyebolts ② (Thread dia. = 10 mm, Pitch = 1.5 mm) and ① (Thread dia. = 12 mm, Pitch = 1.75 mm), and lift transmission case (20) straight up to remove. (See P1)

18. Remove No. 1 ring gear (27). (See P7)

19. Remove No. 1 sun gear (28), No. 2 sun gear (29), and input shaft (30) as one unit. (See P8)

13. Using tool B, check the operating condition and stroke of each piston. (See P2)

- ★ Air check pressure: 5 – 6 kg/cm²
- ★ When carrying out the air check, check for any loss of pressure or bubbles appearing between the piston and housing. Judge from the results if it is necessary to replace the piston seal ring.
- ★ Standard stroke

No. 1	2.6 mm
No. 2	3.2 mm
No. 3	2.4 mm
No. 4	2.4 mm (#60001 – 64855) 3.1 mm (#64856 and up)
No. 5	3.4 mm

20. Remove plate (31). (See P9)

21. Remove plates (32) and discs (33) in turn. (See P10)

- ★ Keep the plates and discs stored in a vertical or horizontal position to prevent any deformation.

14. Remove tie bolts (21). (See P3)

- ★ Keep the washers and O-rings (x 5) in a safe place.

15. Remove No. 1 housing and carrier assembly (22) together with clutch piston. (See P4)

22. Remove snap ring (34), then remove ring gear (35). (See P11, P12)

16. Remove plate (23), then remove No. 1 and 2 piston return springs (24). (See P5)

23. Remove No. 2 ring gear (36). (See P13)

17. Remove discs (25) and plates (26) in turn. (See P6)

24. Remove No. 2, 3 housing assembly (37) together with clutch piston (See P14)

- ★ Keep the plates and discs stored in a vertical or horizontal position to prevent any deformation.

DISASSMBLY OF TRANSFER ASSEMBLY

1. Remove holder (1). (See P1)
2. Turn over the transfer case, put a copper bar in contact and knock out pinion (2). (See P2, P3)
 - ★ When removing the pinion, there is danger that the pinion may fly out, so remove it carefully.
3. Pull out inner race (3) from pinion. (See P3)
4. Remove bolts, then remove plate (4). (See P4, P5)
 - ★ Using forcing screws ⑨ (Thread dia. = 10 mm, Pitch = 1.5 mm, Length = 100 mm), remove cage and bearing assembly adjustment shim.
 - ★ When the cage and bearing assembly is removed from the pinion shaft using forcing screws ⑨, there is danger that the cage at the cage and bearing end may be damaged, so use forcing screws only when removing the adjustment shims.
5. Remove bearing cage (5) and shim (6). (See P6, P7)
 - ★ To make the mounting dimensions the same when assembling, check the number and thickness of the shims, mark with tags, and keep in a safe place.
6. Pull out bearing (7) from cage. (See P8)
7. Remove cover (8). (See P9)
8. Remove gear (9). (See P10)
9. Pull out bearings (10) and (11). (See P11)

GENERAL ASSEMBLY

- ★ Clean all parts, and check for dirt or damage. Coat the sliding surfaces of the bearings, shafts, plates, discs and other parts with engine oil before installing.
 - ★ The piston ring must be installed facing in the correct direction. Install with the side receiving the pressure facing the housing. (See F1)
 - ★ Install the snap ring as shown in the diagram. (See F2)
 - ★ Coat the surface of the outside diameter and inside diameter of the bearing with adhesive (Three Bond: 1373B).
 - ★ Coat the seal ring with grease (G2-LI) before assembling.
1. Set No. 5 housing (58) on block (height: approx. 200 mm). (See P1)
 2. Install output shaft assembly (60). (See P1)
 3. Tighten with mounting bolts (59). (See P1)
 4. Turn over No. 5 housing.
 5. Install No. 5 clutch assembly (61). (See P2)
 6. Assemble No. 4, 5 housing assembly (62) in transfer assembly. (See P2)
 7. Assemble No. 4 sun gear (57), and install snap rings (56) and (55). (See P3)
 8. Assemble No. 3 sun gear (54), and install snap ring (53). (See P4)
 9. Install plate (52). (See P5)
 10. Install guide pins (51). (See P5)
 11. Install No. 4 ring gear (50). (See P5)
 12. Install plates (48) and discs (49) in turn, then springs (47), and put plate (46) on springs (47). (See P6)
 - ★ Free height of spring: 22.4 mm
 13. Assemble piston, and install No. 4 housing (45). (See P6)

CLICK HERE TO **DOWNLOAD** THE COMPLETE MANUAL

- Thank you very much for reading the preview of the manual.
- You can download the complete manual from: www.heydownloads.com by clicking the link below



- Please note: If there is no response to CLICKING the link, please download this PDF first and then click on it.

CLICK HERE TO **DOWNLOAD** THE COMPLETE MANUAL

13. Remove mounting bolts, then remove transmission pump assembly (15). (See P1, P2)

DISASSEMBLY OF SELECTOR AND INCHING VALVE ASSEMBLY D21-6

DISASSEMBLY OF INCHING VALVE

1. Remove cover (1) and shims (2). (See P1, F1)
2. Pull out inching valve spool (3) from body (4), then remove stoppers (5) and (7), springs (6) and (8). (See P1, F1)
3. Remove plug (10) and pull out valve (11). (See P1, F1)
4. Remove valve (12), spring (13) and valve (14) from valve (11) in order. (See P1, F1)
5. Pull out oil seal (15) from cover. (P1, F1)

DISASSEMBLY OF F-R VALVE

6. Pull out F-R spool from body (4). (See P2, F1)
7. Loosen nut (17) and remove yoke (18) from F-R spool. (See P2, F1)
8. Remove plug (19) and oil seal (20) from body. (See P2, F1)

DISASSEMBLY OF SPEED VALVE

9. Remove retainer (21) and remove spring (22) and ball (23). (See P3, F1)
10. Pull out speed spool (24) from body. (See P3, F1)
11. Loosen nut (25), then remove yoke (26) from speed spool. (See P3, F1)
12. Remove plug (27) and oil seal (28). (See P3, F1)

ASSEMBLY OF SELECTOR AND INCHING VALVE ASSEMBLY D21-6

- ★ Clean all parts, and check for dirt and damage. Coat the sliding surfaces of all parts with engine oil before installing.

ASSEMBLY OF SPEED VALVE

1. Fit O-ring and install plug (27) to body (4). (See P3, F1)

 Plug: 4 ± 0.5 kgm

2. Press fit oil seal (28) to body. (See P3, F1)
3. Install yoke (26) to speed spool (24). (See P3, F1)

★ Installed dimension a of yoke: 27 mm (See F2)

4. Tighten locknut (25) securely. (See P3, F1)

 Locknut: 0.8 ± 0.2 kgm

5. Assemble speed spool (24) in body. (See P3, F1)
6. Assemble ball (23) and spring (22) in body. (See P3, F1)

7. Fit O-ring and install retainer (21). (See P3, F1)

 Retainer: 1.5 ± 0.5 kgm

8. Check operating force of speed spool. (See P3, F1)

★ Operating force: 9.5 kg

ASSEMBLY OF F-R VALVE

9. Fit O-ring and install plug (19) to body. (See P2, F1)

 Plug: 4 ± 0.5 kgm

10. Press fit oil seal (20) to body. (See P2, F1)

11. Install yoke (18) to F-R spool. (See P2, F1)

★ Installed dimension b of yoke: 28 mm (See F2)

12. Tighten locknut (17) securely. (See P2, F1)

 Locknut: 0.8 ± 0.2 kgm

13. Assemble F-R spool (16) in body. (See P2, F1)

ASSEMBLY OF INCHING VALVE

14. Assemble valve (14), spring (13) and valve (12) in order, and assemble to body, then fit O-ring and install plug. (See P1, F1)

 Plug: 11 ± 1.5 kgm

15. Assemble shims (9), springs (8) and (6), stoppers (7) and (5) to valve and body (4), then install inching spool to body. (See P1, F1)

★ Standard thickness of shim (9): 2.0 mm

16. Press fit oil seal (15) to cover (1). (See P1, F1)

 Oil seal: Grease (G2-LI)

17. Fit O-ring and shim (2), and install cover (1) to body. (See P1, F1)

★ Standard thickness of shim (2): 2.0 mm

INSTALLATION OF STEERING CLUTCH ASSEMBLY

1. Raise steering clutch assembly (22), and set inside clutch case. (See P1)

- ★ Be careful to install the brake band facing in the correct direction.

2. Rotate track with jack ①, and tighten mounting bolts (23) of steering clutch assembly (22) and bolts (24) of brake drum side. (See P2, P3)

- ★ Tighten 2 or 3 mounting bolts on opposite sides, align the bolt holes of the pilot, then tighten in turn on opposite sides.

3. Install lift springs (21) of brake band. (See P4)

- ★ Be careful of the length of the spring when installing.
- ★ Free height of lift spring: Front 57.4 mm
Rear 96.5 mm

4. Fit gasket to clutch cover (20) and set adjustment shaft and end in brake band, then install clutch cover. (See P5)



Gasket: Gasket sealant (LG-1)

5. Tighten brake adjustment nut (19) at 5 kgm, and bring lining into close contact with drum. (See P6)

- ★ After tightening at 5 kgm, return brake adjustment nut 4 turns. (See P6)
- ★ For details of fine adjustment, see 22 TESTING AND ADJUSTING.

6. Install cap (18). (See P7)

7. Connect steering rod (12). (See P7)

8. Assemble bolts (14), and install tube (16) and sleeve (17). (See P7)

- ★ Bend the cotter pin securely.
- ★ For details of fine adjustment of the rod, see 22 TESTING AND ADJUSTING.

9. Set steering valve assembly (15) together with plate on sleeve (17) and install temporarily. (See P8)

10. Tighten tube mounting bolts (14). (See P8)

REMOVAL OF BEVEL GEAR SHAFT AND BEVEL GEAR ASSEMBLY

Special tools

	Part No.	Part Name	Q'ty
A	791-417-6000	Remover and installer	1
B	791-417-2000	Remover B	1
C	791-417-1300	Wrench	1
D	791-417-1400	Seal guide	1
E	791-417-1500	Remover	1

1. Remove steering clutch assembly.
For details, see 23 REMOVAL OF STEERING CLUTCH ASSEMBLY.

2. Remove drain plug (1) and drain oil from bevel gear case. (See P1)



Bevel gear case: Approx. 12 ℓ

3. Remove cover (2) of bevel gear shaft top. (See P2)

4. Remove lock plate (3) of hub nut. (See P3)

5. Using tool A, remove hub nut (4). (See P4)
★ When loosening the locknut, fix with stopper ① to prevent it from turning.

6. Using tool B, pull out hub (5). (See P5)

7. Remove release yoke (6). (See P5)

8. Remove lock plate (7) of adjustment nut. (See P6)

9. Loosen bevel gear mounting nut (8). (See P6)
★ When removing the bevel gear, the nut is difficult to loosen, so loosen it at this point.

10. Using tool C, remove left and right adjustment nuts (9). (See P7)

11. Sling bevel gear assembly, and set tool D in position. (See P8)

12. Screw bolts (Thread dia. = 8 mm, Pitch = 1.25 mm) into bearing cage (10), support with a bar, then hit with a hammer at the opposite end to knock out. (See P8)

17. Using tool A, tighten hub nut (4). (See P1, P2)

 Hub nut thread: Anti-friction compound (LM-P)

 Hub nut: 27 ± 3 kgm

18. Install lock plate (3) of hub nut, and lock hub nut. (See P3)

19. Measure dimension a between left and right release yokes. (See P4, F1)

- ★ Standard value of dimension a: 121 ± 0.5 mm (From center of machine to tip of adjustment bolt)
- ★ If dimension a is not within the standard value, adjust as follows.
 - Loosen locknut (24), and adjust with adjustment screw (25).

20. Fit gasket and install bevel gear shaft top cover (2). (See P5)

 Gasket: Gasket sealant (LG-1)

 Bolt: Thread tightener (LT-2)

21. Install steering clutch assembly.
For details, see 23 INSTALLATION OF STEERING CLUTCH ASSEMBLY.

22. Tighten drain plug of bevel gear case.

23. Add engine oil through oil filler (26) to the specified level. (See P6)



Bevel gear case: Approx. 12 ℓ

12. Pull out bearings (15) and (16) from sprocket shaft (17). (See P1, P2)

13. Remove lock plate and nut (18), then remove driven gear (19) from shaft (17). (See P3)

MAIN CLUTCH AND STEERING PUMP

D20-6

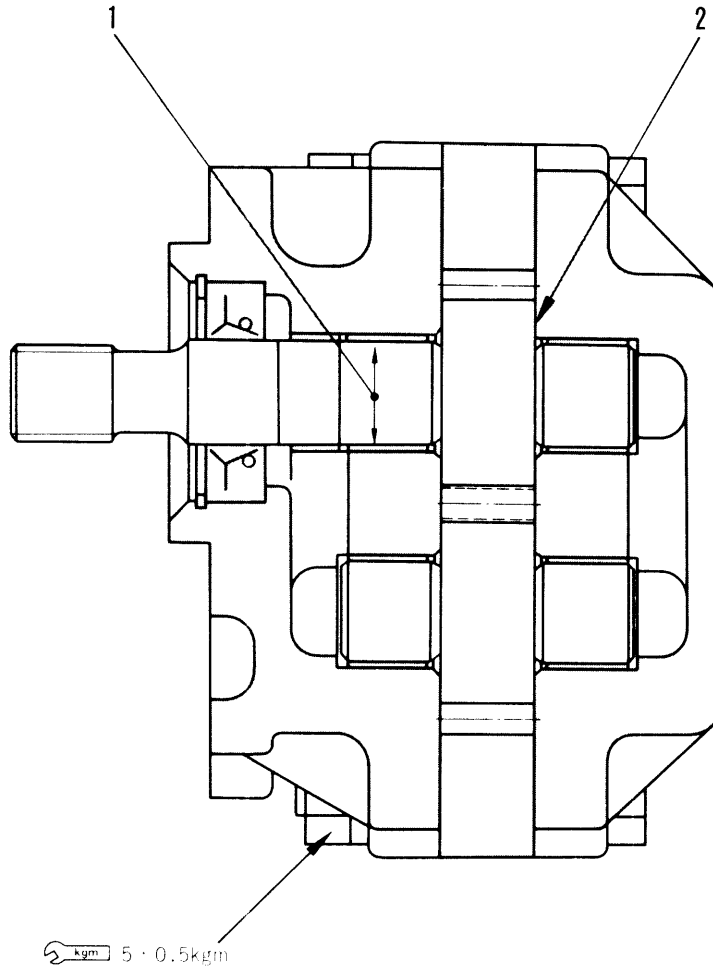

I03F06071

Unit: mm						
No.	Check item	Criteria			Remedy	
1	Clearance between plane bearing and gear shaft	Standard clearance		Clearance limit	Replace	
		0.050 – 0.070		0.15		
2	Side clearance between gear case and gear	0.020		0.07		
	Discharge (Class-CD SAE 10W, 45 – 55°C)	Revolution (rpm)	Pressure (kg/cm ²)	Standard discharge (ℓ/min)	Repair limit discharge (ℓ/min)	—
		2,800	30	25		

Unit: mm

No.	Check item	Criteria				Remedy	
		Standard size		Repair limit			
7	Thickness of a disc	Standard size		Repair limit		Replace	
		3.0		2.7			
8	Thickness of a plate	3.2		2.9			
9	Thickness of a pressure plate	3.2		3.05			
10	Overall thickness of three discs and three plates for No.1 clutch	18.6		16.8			
11	Overall thickness of two discs and two plates for No.2 and No.3 clutches	12.4		11.2			
12	Overall thickness of two discs and two plates for No. 4 clutch	12.4		11.2			
13	Overall thickness of two discs and three plates for No.5 clutch	15.6		14.2			
14	Outside diameter of oil seal contact surface on input coupling	Standard size	Tolerance		Repair limit		Repair or replace
		65.0	0	-0.074	64.9		
15	Outside diameter of oil seal contact surface on output shaft	50.0	0	-0.062	49.9	Replace	
16	Wear of seal ring on No.1 carrier	Width	4.0	-0.01 -0.03	3.76		
		Thickness	4.9	± 0.12	4.70		
17	Wear of seal ring on rear sleeve	Width	3.0	-0.01 -0.03	2.82		
		Thickness	3.8	± 0.12	3.65		
18	Clearance between lubrication valve spool and clutch housing	Standard size	Tolerance		Standard clearance	Clearance limit	Replace
			Shaft	Hole			
		12.0	-0.020 -0.030	+0.027 0	0.020 - 0.057	0.08	
19	No.1 and No.2 clutch spring	Standard size			Repair limit		
		Free length	Installation length	Installation load	Free length	Installation load	
		17.3	15.9	9.95 kg	16.2	8.53 kg	
20	No.3 clutch spring	22.4	18.5	8.25 kg	21.0	7.07 kg	
21	No.4 clutch spring	35.0	24.1	11.9 kg	32.9	10.12 kg	
22	No.5 clutch spring	23.7	19.0	6.6 kg	22.3	5.7 kg	
23	Lubrication valve spring	25.4	23.6	1.93 kg	23.9	1.65 kg	
24	Thickness of shim for bevel pinion bearing cage	2.0				Adjust	

STEERING CONTROL VALVE

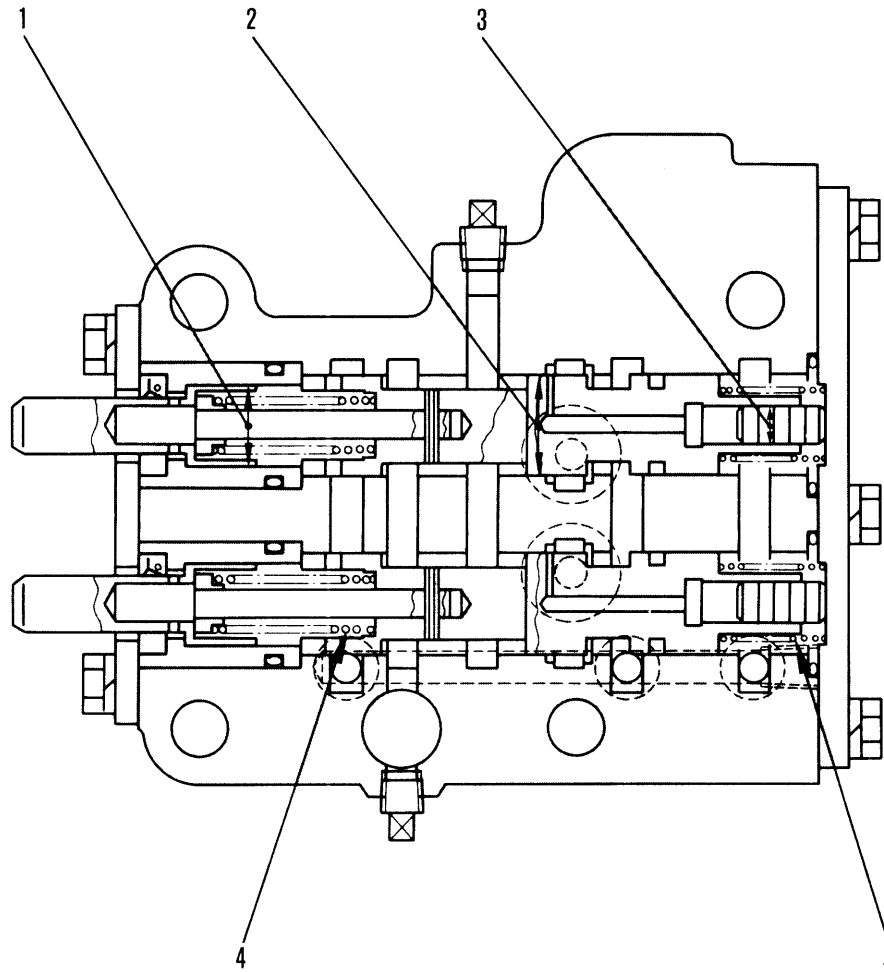

I03F06073

Unit: mm

No.	Check item	Criteria				Remedy
		Standard size	Tolerance		Standard clearance	
Shaft	Hole					
1	Clearance between valve stem and sleeve	20	-0.035 -0.045	+0.013 0	0.035 - 0.058	0.08
2	Clearance between valve spool and body	25	-0.035 -0.045	+0.013 0	0.035 - 0.058	0.08
3	Clearance between valve spool and piston	10	-0.030 -0.040	+0.015 0	0.030 - 0.055	0.08
4	Modulating valve spring	Standard size			Repair limit	
		Free length	Installation length	Installation load	Free length	Installation load
		59.7	40.0	8.63 kg	58.7	8.2 kg
5	Spool return spring	87.0	25.0	4.04 kg	83.9	3.84 kg

Replace

TRACK GROUP

D20, 21A, P, S, Q-6
D20, 21P-6A

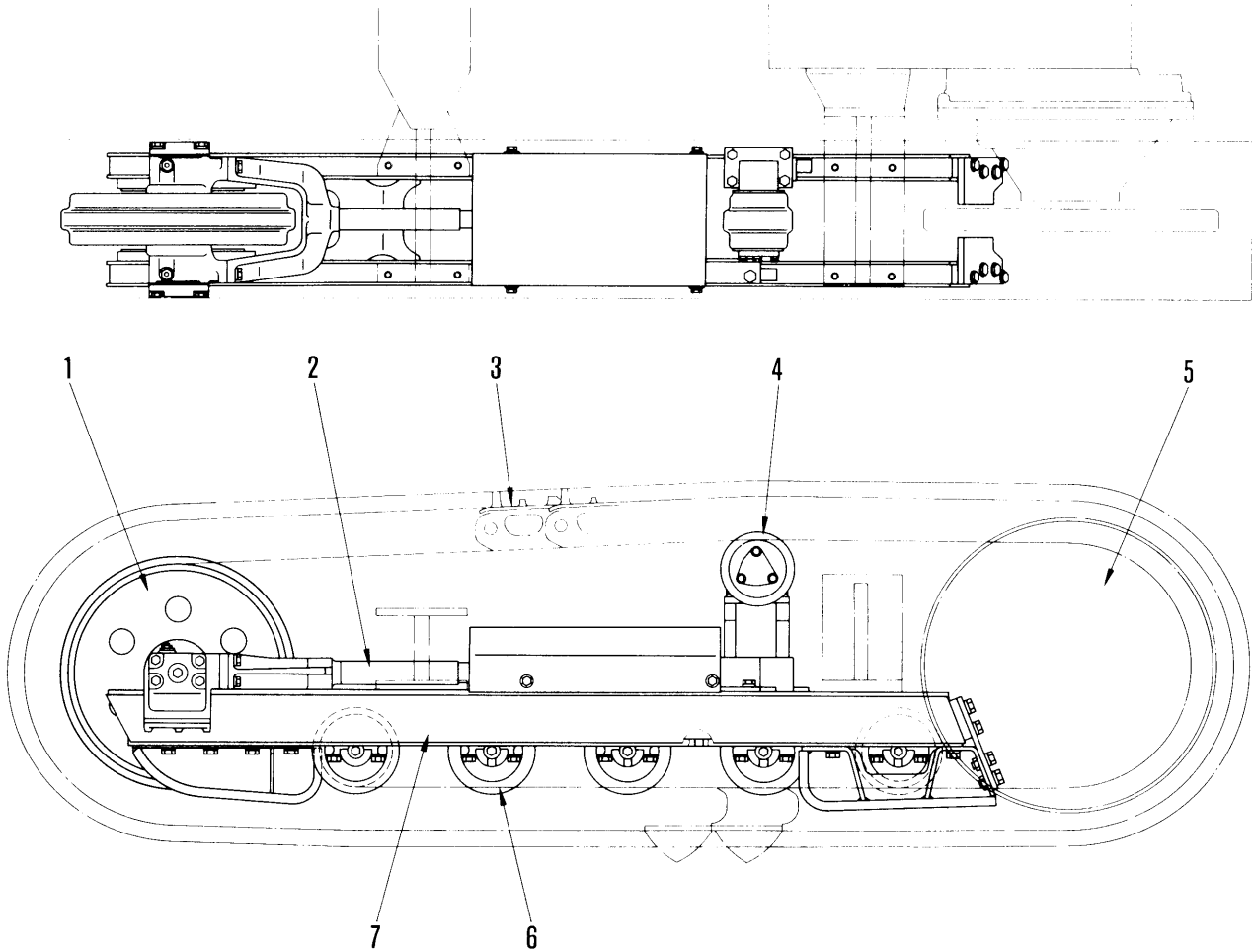

103F06039

1. Idler
2. Idler cushion
3. Track
4. Carrier roller
5. Sprocket
6. Track roller
7. Track frame

OUTLINE

- The track group supports the whole machine weight, and moves the machine by driving track (3) using the motive force of the power train transmitted from sprocket (5).
- The D20, 21A, P, S, Q-6 and D20, 21P-6A has five track rollers on each side.

P1

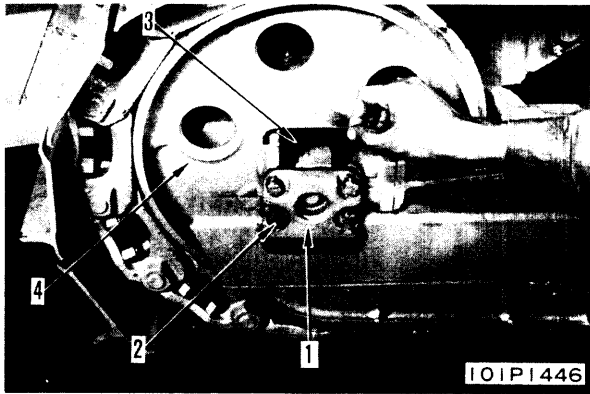

P6

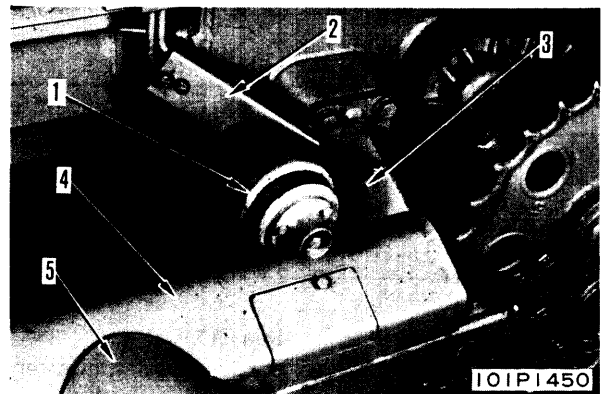

P2

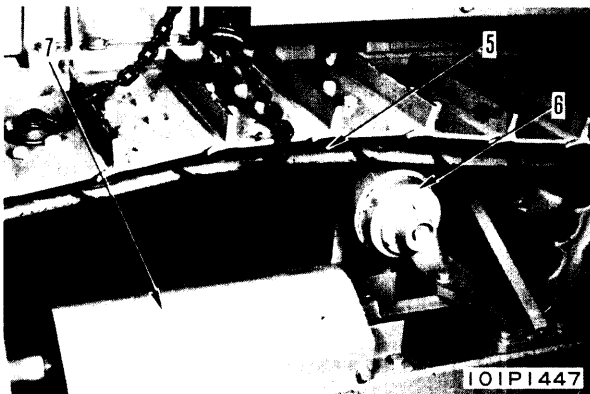

P7

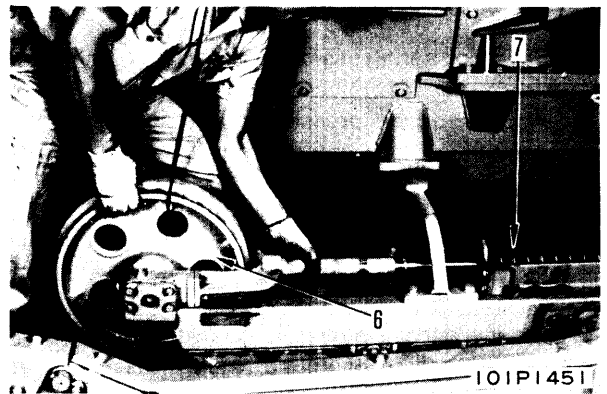

P3

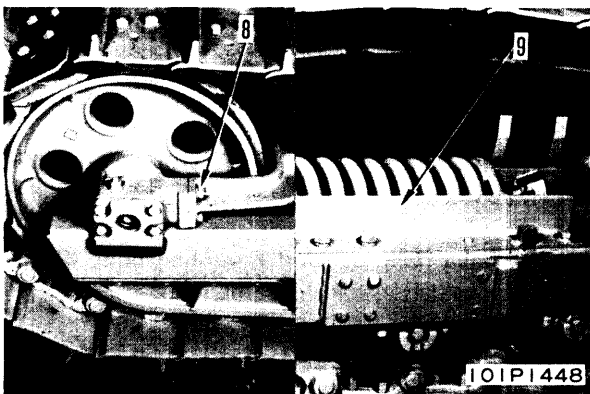

P4

P8

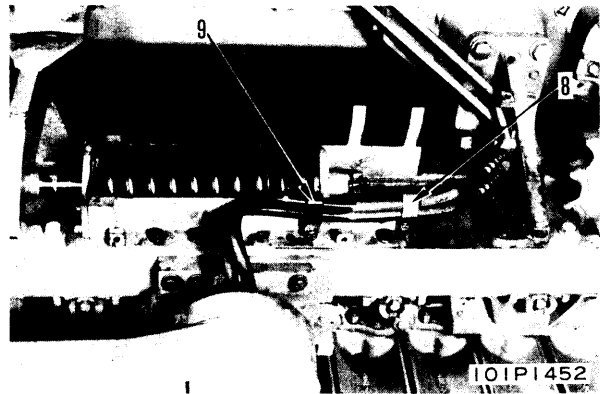

P5

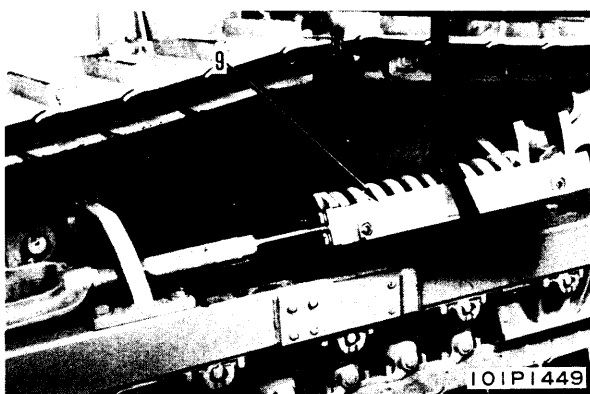

P9

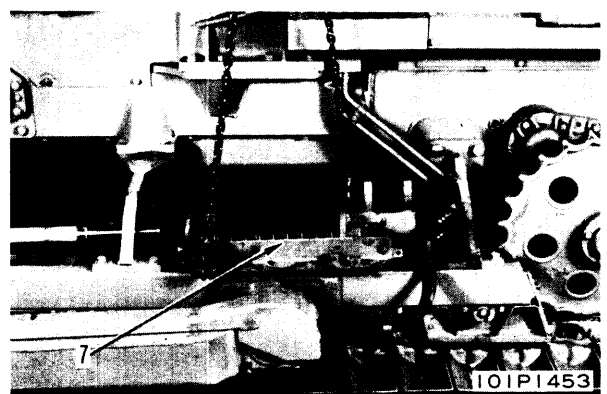

IDLER

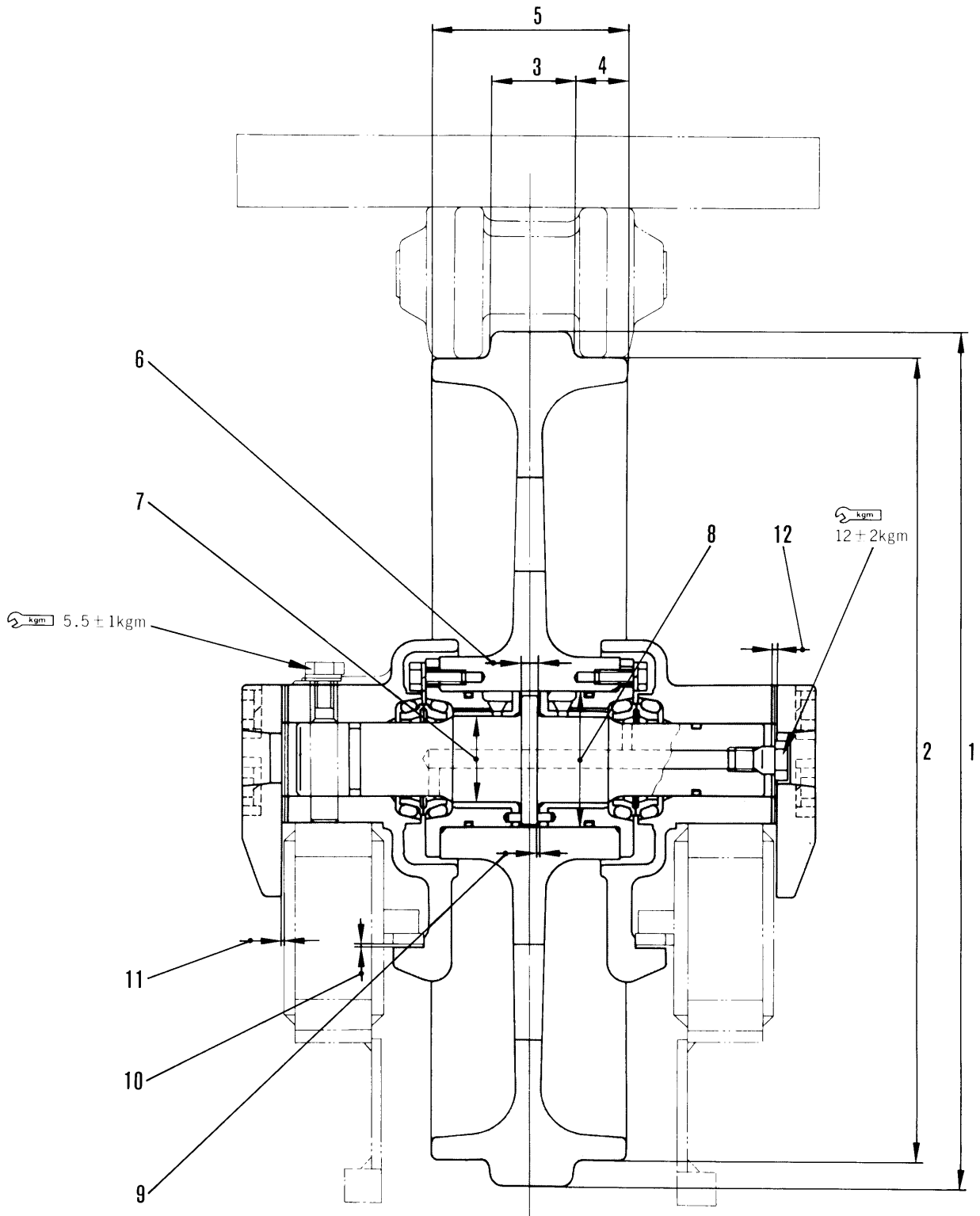

103F06079

HYDRAULIC CONTROL

D20, 21P, PL, PLL-6

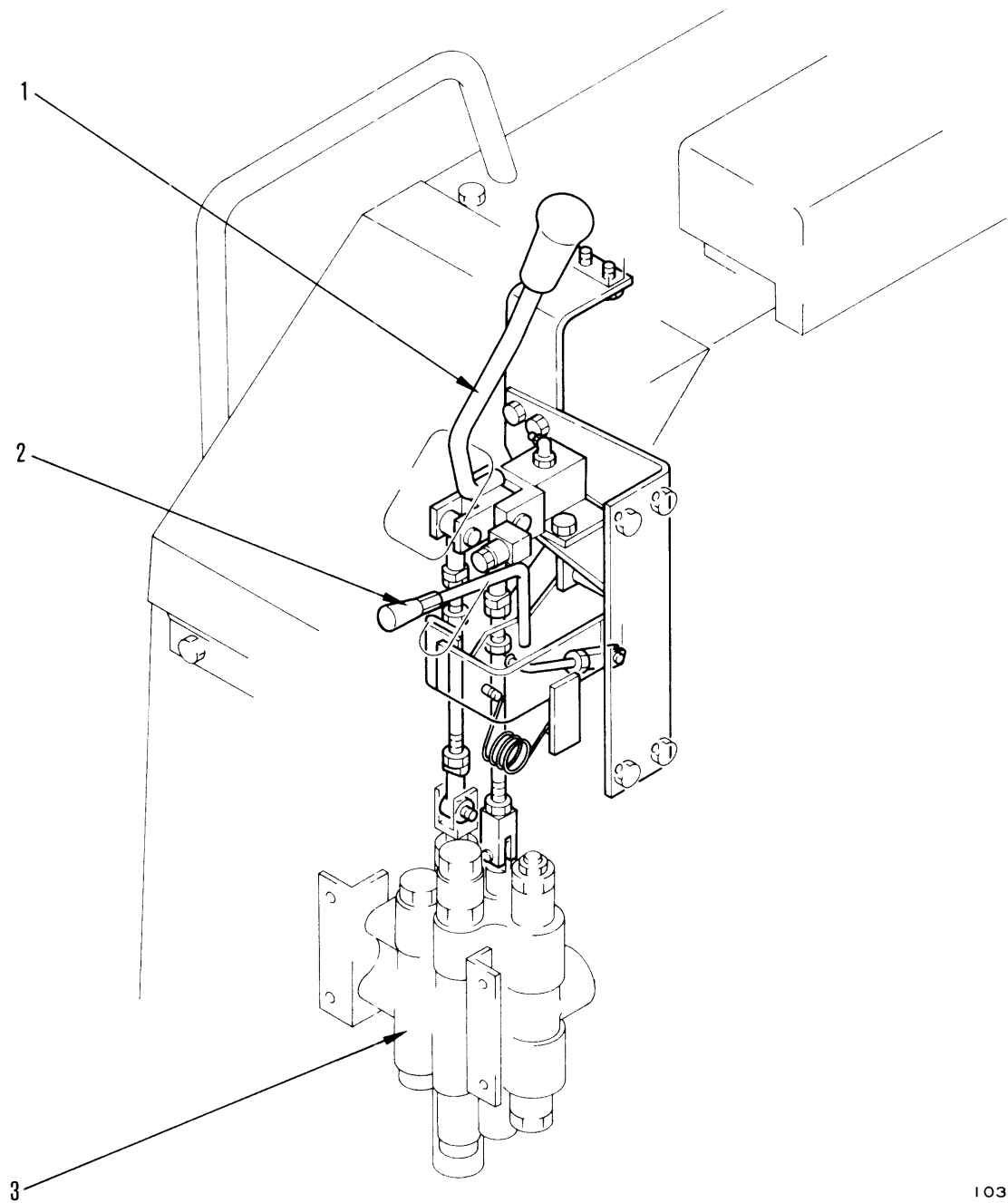

I03F06054

1. Work equipment control lever
(For blade lift and tilt)
2. Lock lever
3. Hydraulic control valve

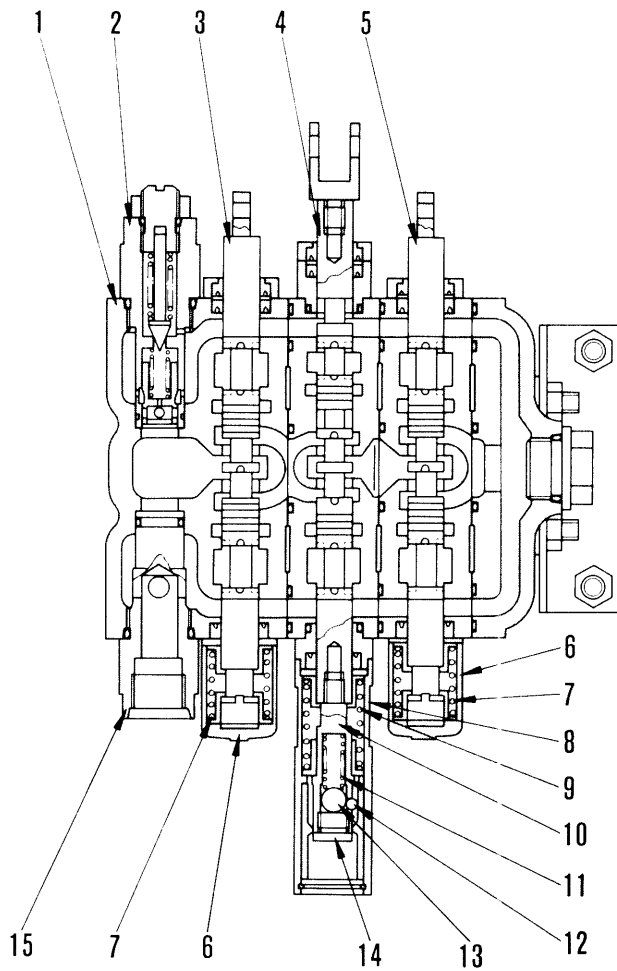

Section A-A

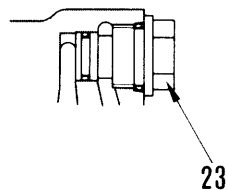

Section C-C

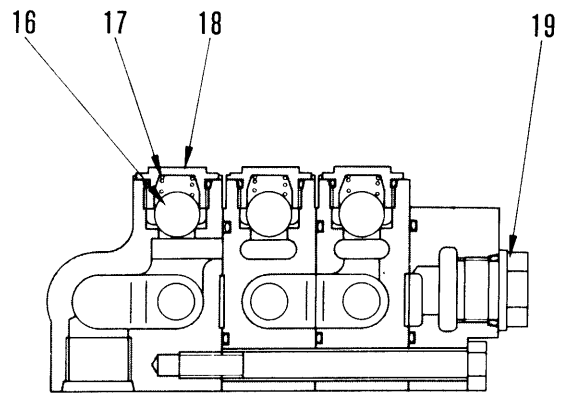

Section B-B

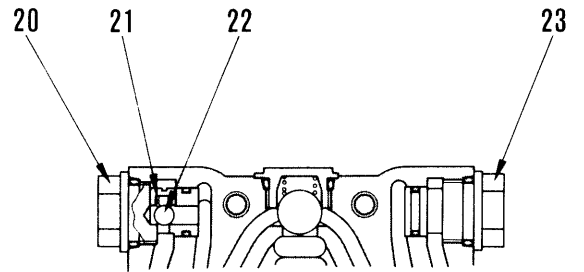

Section D-D

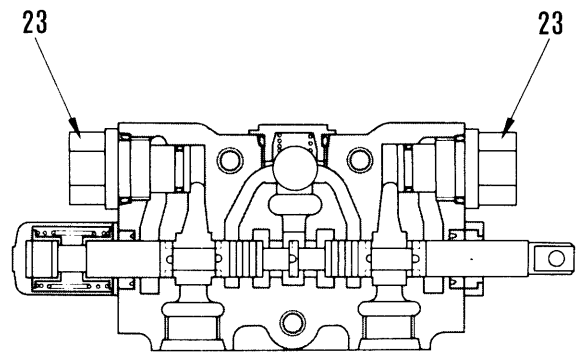

Section E-E

- | | | |
|---------------------------|----------------------|--------------------------|
| 1. Valve body | 9. Return spring | 17. Check valve spring |
| 2. Main relief valve | 10. Detent plug | 18. Plug |
| 3. Blade tilt spool | 11. Detent spring | 19. Plug |
| 4. Blade lift spool | 12. Detent ball | 20. Plug |
| 5. Blade angle spool | 13. Detent ball | 21. Suction valve spring |
| 6. Spring case | 14. Plug | 22. Suction valve ball |
| 7. Return spring | 15. Plug | 23. Plug |
| 8. Detent and spring case | 16. Check valve ball | |

103F06048

HYDRAULIC CYLINDER D20, 21P, PL, PLL-6

1. BLADE LIFT CYLINDER

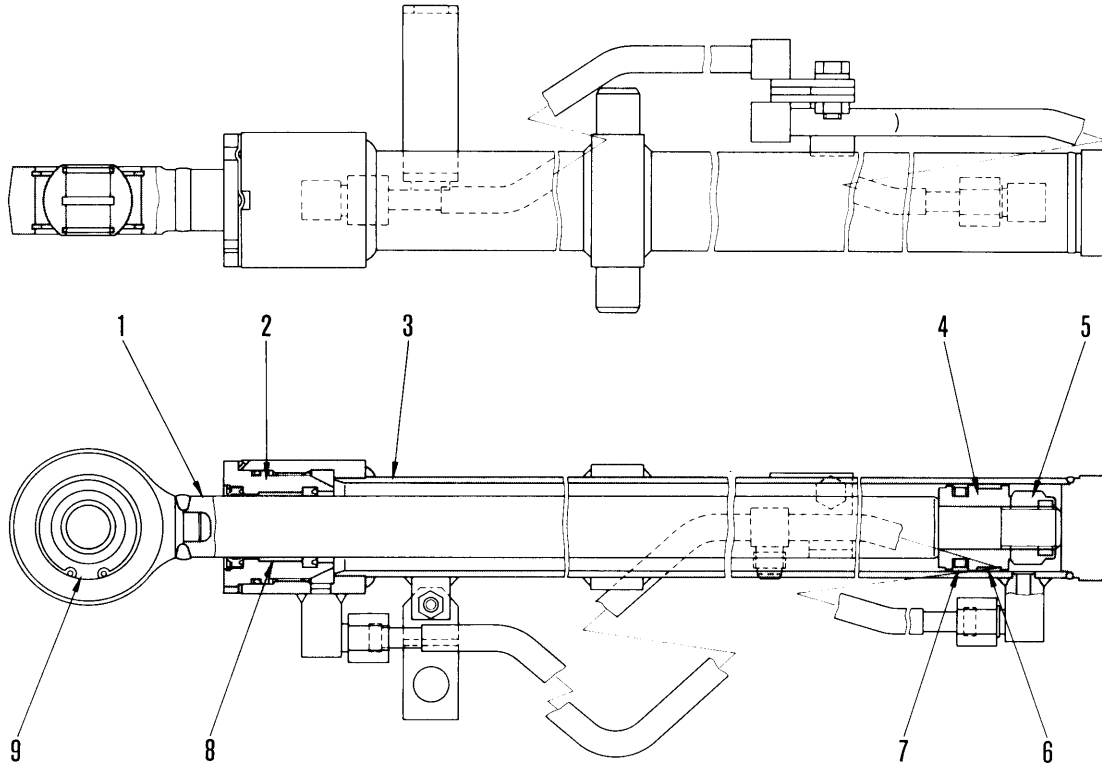

F10306073

2. BLADE TILT CYLINDER

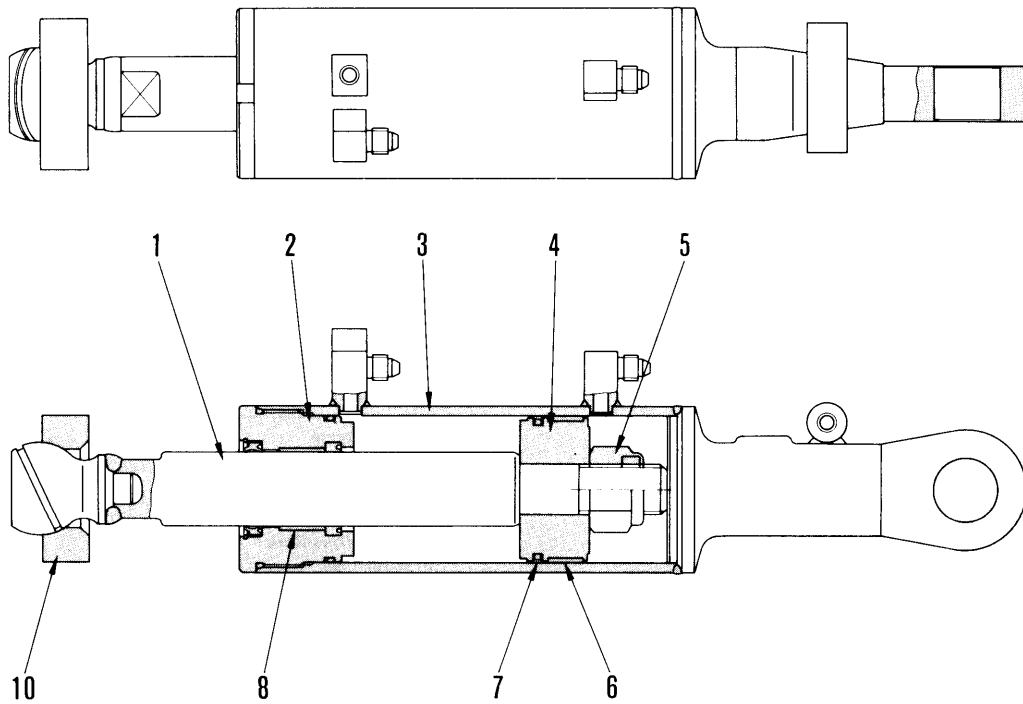

F10306074

TESTING PERFORMANCE OF WORK EQUIPMENT

★ Oil temperature when measuring: 45 – 55°C

1. Measuring RAISE and LOWER speed of blade

- 1) Start the engine, and lower the blade to the ground.
- 2) Measure the time taken to raise the blade from the ground to the maximum lifting height.
Measure with the engine at low idling, and engine at full throttle.

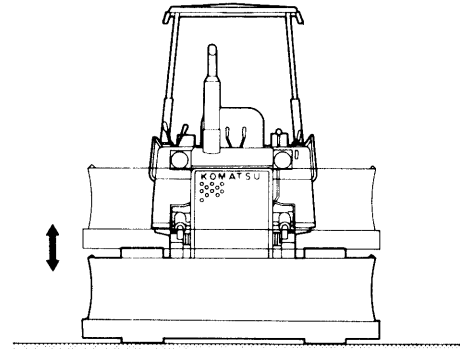

103F06211

2. Measuring TILT speed of blade

- 1) Start the engine, and raise the blade about 300 mm from the ground.
- 2) Measure the time taken to tilt the blade from maximum left to maximum right tilt.
Measure with the engine at low idling, and engine at full throttle.

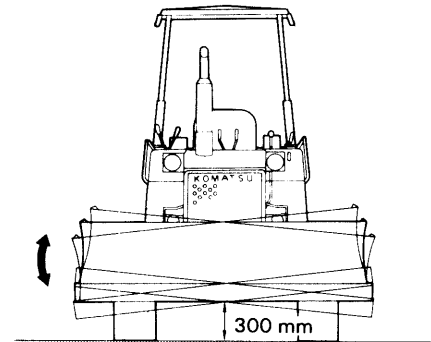

103F06212

3. Measuring ANGLE speed of blade

- 1) Start the engine, and raise the blade about 300 mm from the ground.
- 2) Measure the time taken to angle the blade from maximum left to maximum right angle.
Measure with the engine at low idling, and engine at full throttle.

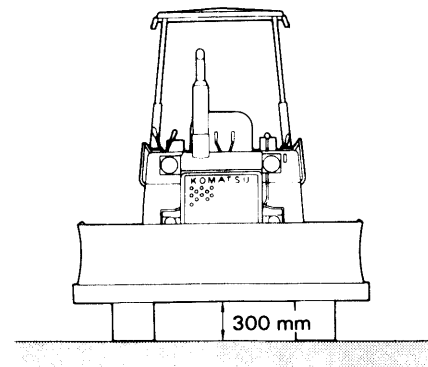
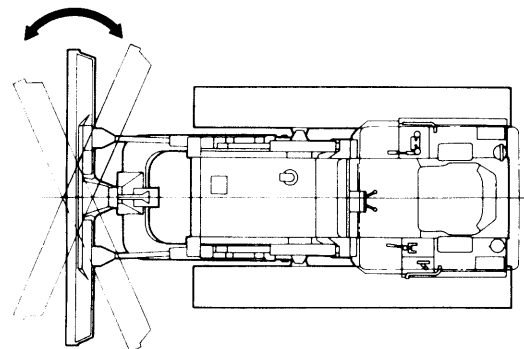

103F06213

8. Hydraulic drift of blade tilt cylinder is excessive.

Ask the operator the following questions

- Did the hydraulic drift of tilt cylinder suddenly become large? → Damaged parts.
- Did the hydraulic drift of tilt cylinder gradually become large? → Worn parts.

Check before troubleshooting

- If the rod of control lever is disconnected from the control valve spool, is the hydraulic drift of tilt cylinder normal? → Bend of rod or seizure of rod bushing.

Confirmation of trouble

- Check for the amount of hydraulic drift compared with "standard value table" when tilting.

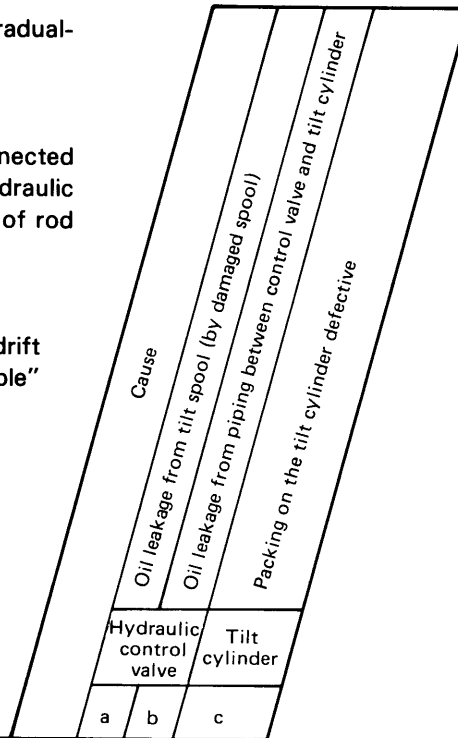

No.	Problems	Remedy	Cause		
			a	b	c
			△ X	△ X	X
1	Tilt blade to maximum left, remove head piping from tilt cylinder, run engine at low idling and operate control lever to LEFT TILT. Oil comes out from head end of tilt cylinder. (For power angle and tiltadozer)				○
2	Tilt blade to maximum right, remove head piping from tilt cylinder, run engine at low idling and operate control lever to RIGHT TILT. Oil comes out from head end of tilt cylinder. (For straight tiltadozer)				○
3	Oil does not come out at items 1 and 2.		○	○	

The following symbols are used to indicate the action to be taken when a cause of failure is located.

- X: Replace △: Repair
A: Adjust C: Clean

18. Bucket dump speed is slow.

Check before troubleshooting

- Is oil quantity in hydraulic tank normal?
- Are the travels of control lever and control valve spool normal?

Check the trouble

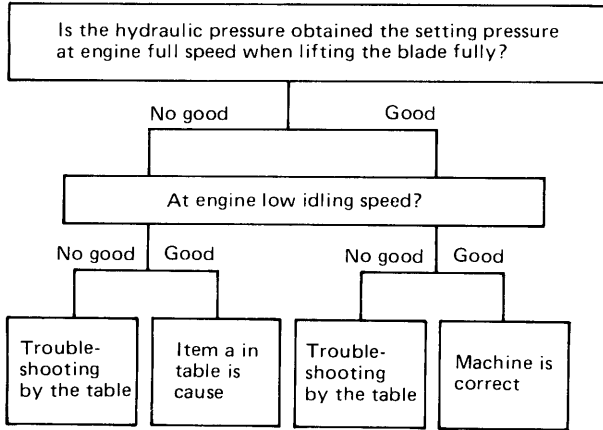

Cause	Strainer clogged	Hydraulic pump sucking air	Hydraulic pump defective	Drop of main relief valve setting pressure, blocked orifice and valve defective	Acting of check valve defective	Drop of safety valve setting on dump pressure	Packing on dump cylinder defective
	Hydraulic pump			Hydraulic control valve		Dump cylinder	
	a	b	c	d	e	f	g

No.	Problems	Remedy							
			C	Δ	X	A	Δ	C	X
1	Hydraulic pressure is low at engine full throttle when raising the lift arm fully.		○	○	○				
2	Hydraulic pressure is normal at engine full throttle when raising the lift arm fully.						○	○	
3	Unusual noise is heard from hydraulic pump.		○						
4	Dump bucket to maximum, remove head piping from dump cylinder, run engine at low idling and operate control lever to DUMP. Oil comes out from head end of dump cylinder.							○	
5	Discharge of hydraulic pump is too small.		○	○					
6	Raising speed of lift arm is proper.						○		
7	Bucket dump speed is slow when operating the control lever, but hydraulic pressure is higher.					○			

Troubleshooting tools	Hydraulic tester	
	Flow meter kit	

The following symbols are used to indicate the action to be taken when a cause of failure is located.

X: Replace Δ: Repair
 A: Adjust C: Clean

F1

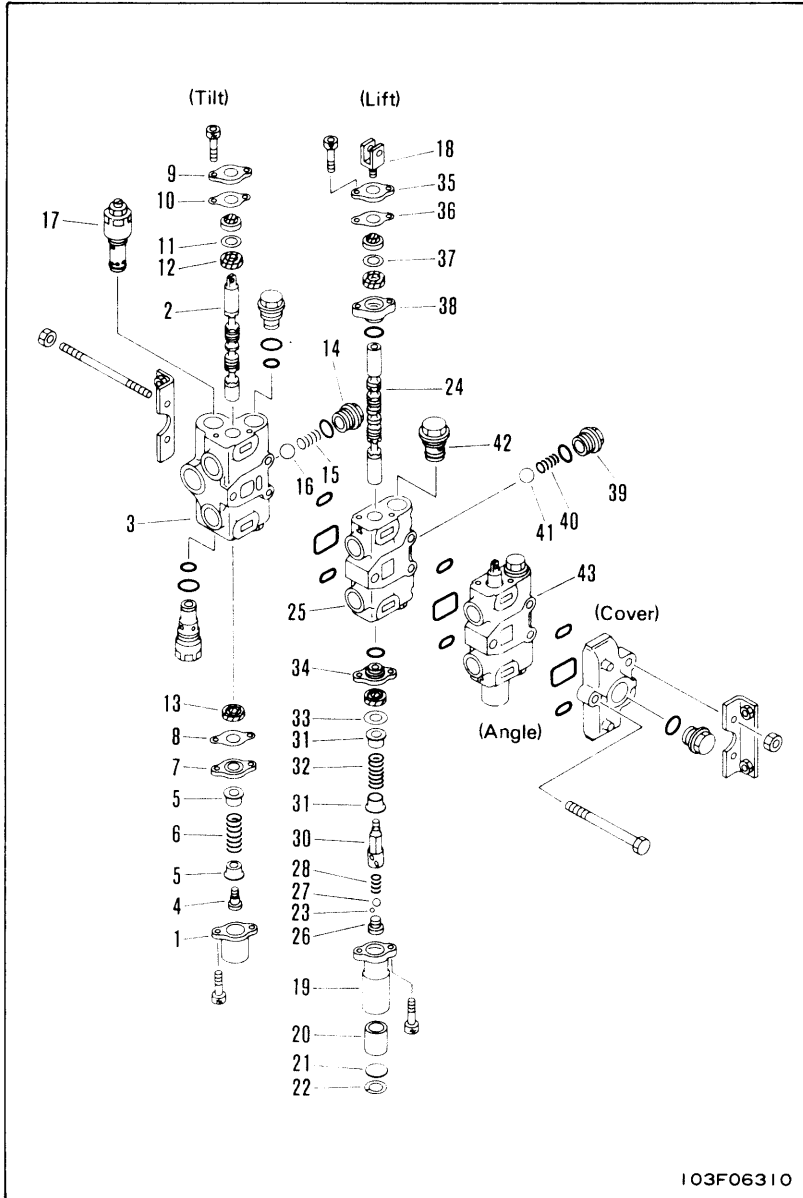

F2

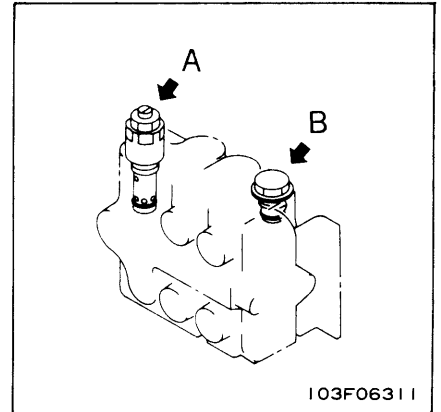

F3

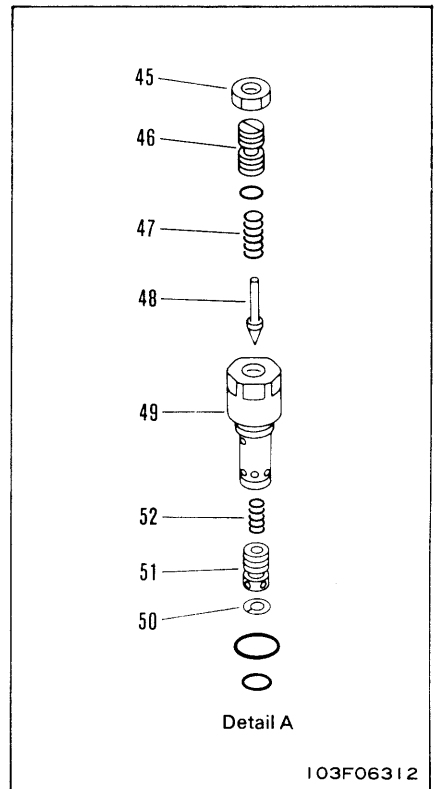

F4

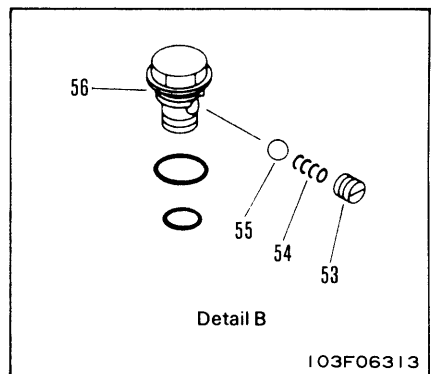

P1

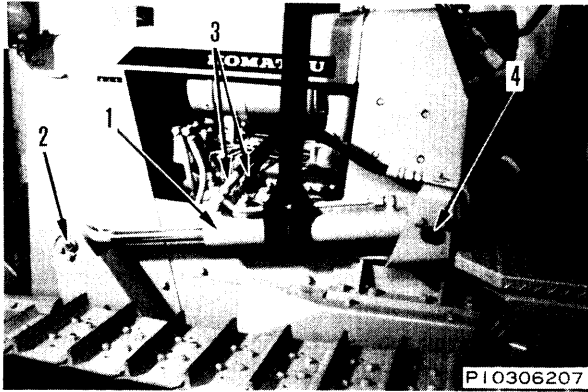

P10306207

P4

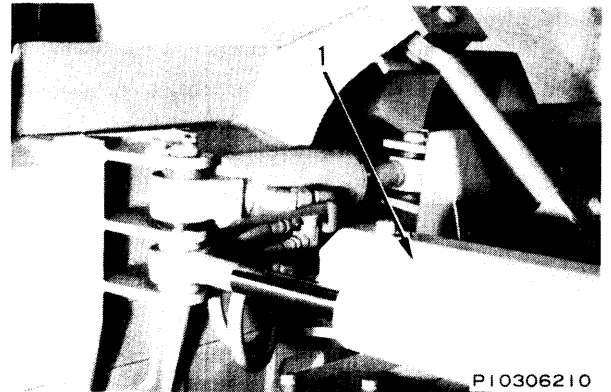

P10306210

P2

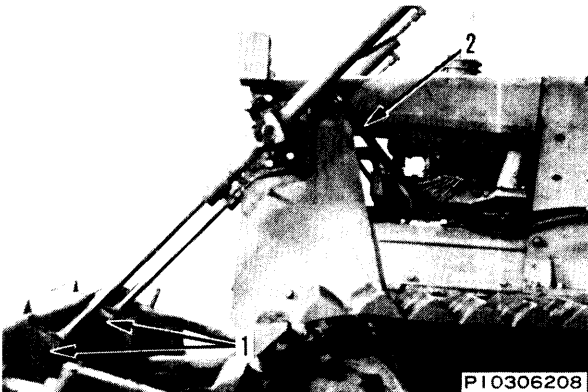

P10306208

P5

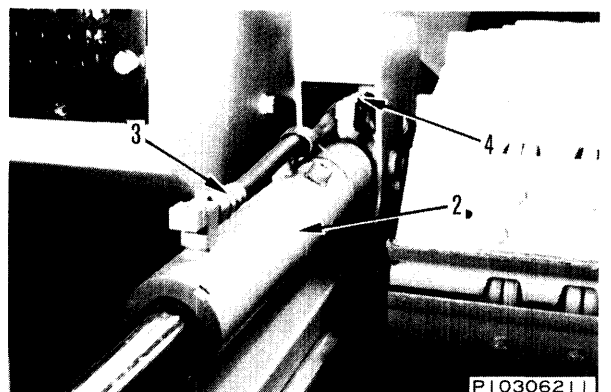

P10306211

P3

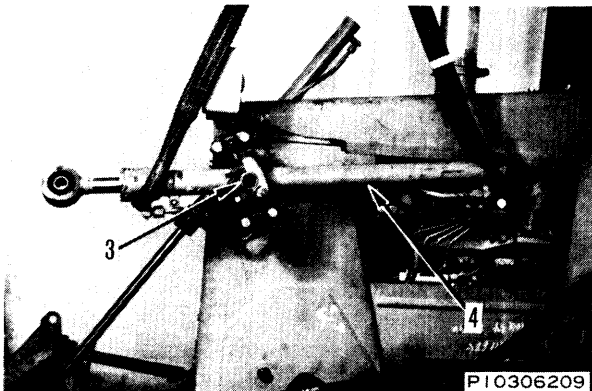

P10306209

P6

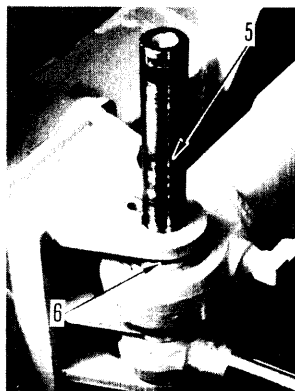

P7

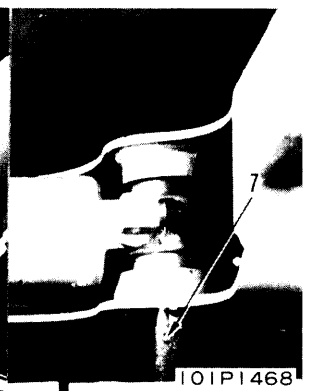

P101468

HYDRAULIC CONTROL VALVE

D20, 21A-6, D21E-6,
D20, 21P-6A, D21P-6B

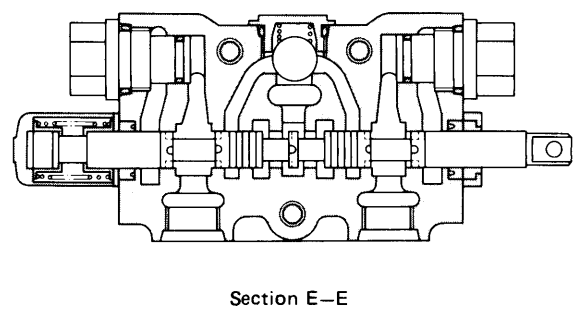
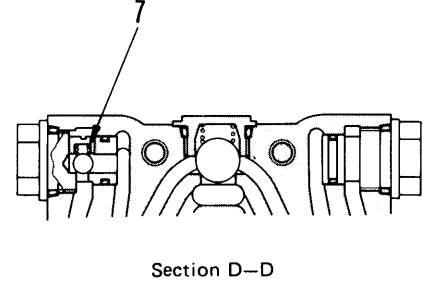
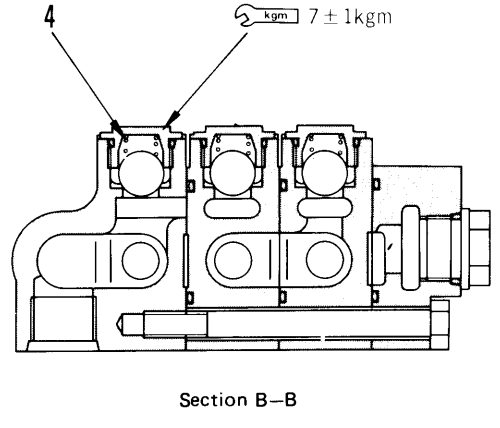
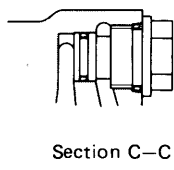
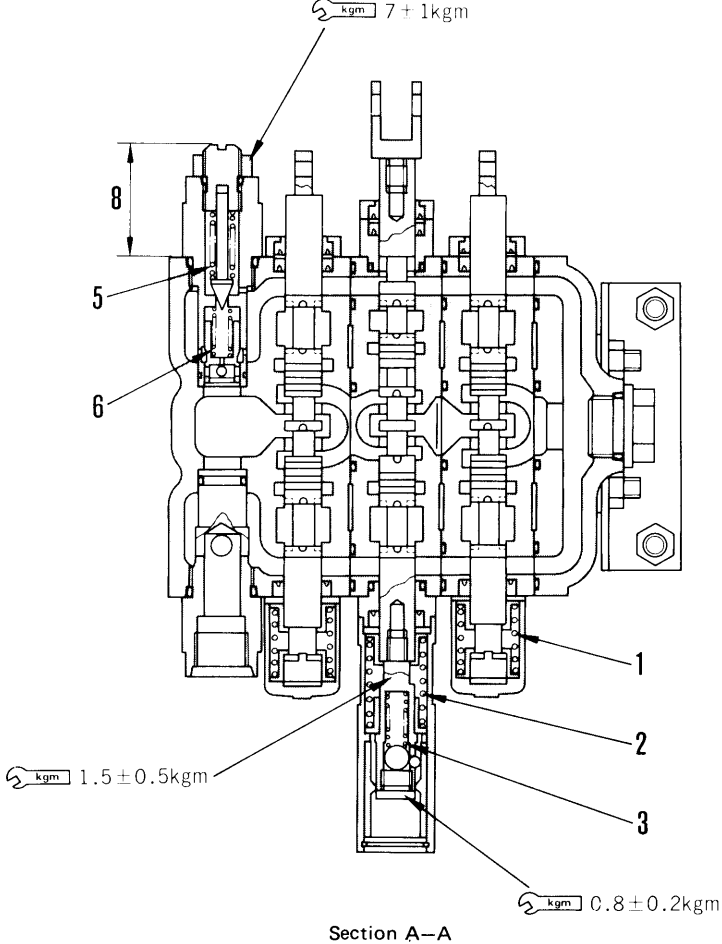

I 03F06087

WORK EQUIPMENT

71 STRUCTURE AND FUNCTION

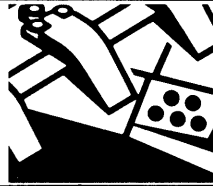

Power angle and tilt dozer (D20, 21A, E-6, D20, 21P-6A, B)	71- 2
Straight tilt dozer (D20, 21P, PL, PLL-6) ...	71- 4
Bucket and link (D20, 21S, Q-6, D21S-6A) .	71- 6

REMOVAL OF BLADE



D20, 21A, E-6, D20, 21P-6A,B

- ★ Put block ① under the U-frame and set work equipment in position. (See P1)
- 1. Remove lock plate, and pull out connecting pin (1). (See P2)
- 2. Remove lock pin, and pull out connecting pin (2), then disconnect pitching rod (3). (See P2).
- 3. Remove left and right lock plates, then pull out connecting pins (4), and disconnect angle cylinder assemblies (5) from blade. (See P2)
- 4. Remove clamp (7) of tilt hose (6). (See P3)
- 5. Move tilt cylinder assembly (8) towards U-frame. (See P5)
- 6. Sling blade (9), and remove cap (10), then lift off blade to front. (See P4, P5)

 Blade: 215 kg

INSTALLATION OF BLADE

D20, 21A, E-6, D20, 21P-6A,B

- ★ Set block ① under the U-frame, then set the U-frame in position. (See P1)
- 1. Sling blade (9), align mount of U-frame, then install cap (10), and secure blade. (See P4, P5)
 -  Cap mount: Grease (LC-G)
 -  Mounting bolt: 95 ± 10 kgm
- 2. Install tilt cylinder assembly (8). (See P5)
- 3. Move tilt cylinder assembly (8) towards blade, and install clamp (7) of tilt hose (6). (See P5, P3)
- 4. Install angle cylinder assembly (5) to blade, align with mounting hole of tilt cylinder, knock in connecting pin (4), then lock with lock plate. (See P2)
- 5. Assemble collar and bushing, and install pitching rod (3), knock in connecting pin (2), then secure with lock pin. (See P2)
- 6. Knock in connecting pin (1), and lock with lock plate. (See P2)
 -  Pin: Grease (G2-LI)
- 7. After completion of installation, coat the pitching rod pins of tilt cylinder and lift cylinder with grease (G2-LI).

REMOVAL OF BLADE

D20, 21P, PL-6

1. Disconnect tilt cylinder assembly (1) from blade. (See P6)
 - ★ Check the number and thickness of removed shims (2), and keep in a safe place. (See P7)
2. Disconnect tilt brace (3) from blade. (See P8)
 - ★ Check the number and thickness of removed shims (4), and keep in a safe place.
3. Remove left and right center braces (5). (See P9)
 - ★ Check the number and thickness of the removed shims, and keep in a safe place.
4. Sling blade (6), pull out pins (7) and (8), then lift off blade. (See P10)

 Blade: 210 kg

INSTALLATION OF BLADE

D20, 21P, PL-6

1. Lift up blade (6), and set in mounting position, then press fit pins (7) and (8). (See P10)
2. Fit shim, and install left and right center braces (5). (See P9)
 - ★ Standard shim thickness: 3.0 mm
3. Assemble shim (4), and connect tilt brace (3) to blade. (See P8)
 - ★ Standard shim thickness: 3.0 mm
4. Assemble shim (2), and connect tilt cylinder assembly (1) to blade. (See P7, P6)
 - ★ Standard shim thickness : 3.0 mm
5. After completion of installation, coat the pins of the left and right center braces, tilt cylinder, and tilt brace with grease (G2-LI).

CLICK HERE TO **DOWNLOAD** THE COMPLETE MANUAL

- Thank you very much for reading the preview of the manual.
- You can download the complete manual from: www.heydownloads.com by clicking the link below



- Please note: If there is no response to CLICKING the link, please download this PDF first and then click on it.

CLICK HERE TO **DOWNLOAD** THE COMPLETE MANUAL