

SHOP MANUAL

KOMATSU

D155C-1

MACHINE MODEL SERIAL No.

D155C-1 **15001 and up**

CLICK HERE TO **DOWNLOAD** THE COMPLETE MANUAL

- Thank you very much for reading the preview of the manual.
- You can download the complete manual from: www.heydownloads.com by clicking the link below



- Please note: If there is no response to CLICKING the link, please download this PDF first and then click on it.

CLICK HERE TO **DOWNLOAD** THE COMPLETE MANUAL

5. HANDLING LOCKING DEVICES

Nuts and bolts which cannot be checked visually from the outside or which are located in vital areas must be firmly locked into position with wires, cotter pins, and lock washers. Never reuse these locking devices.

1. Lock wire

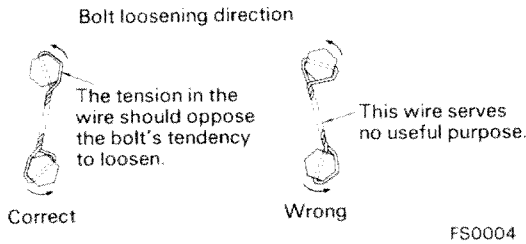

2. Cotter pin

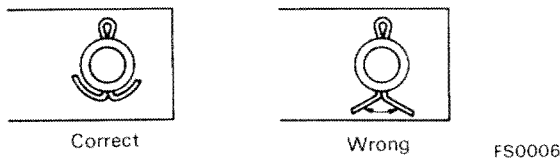
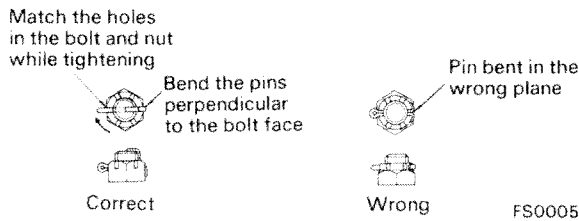

- Bend the head and ends of the cotter pin upwards as far as possible.

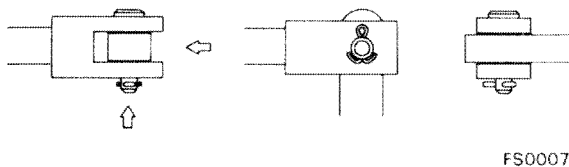

3. Lock washer

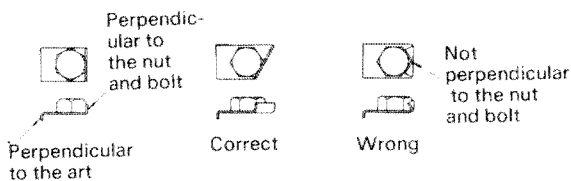

4. Thread tightener

- 1) Wash and degrease the bolt and bolt hole with trichloroethylene and dry. Coat the bolt threads with two or three drops of thread tightener and tighten the bolts.
- 2) After an hour had passed, the bolt cannot be loosened or tightened any further. If retightening becomes necessary, the bolt must be completely removed, the old thread tightener removed, and a new coat applied.

6. PRECAUTIONS FOR PRESS-FITTING

- Coat the surfaces of the parts to be press-fitted with anti-friction grease (molybdenum disulfide) – unless they are tapered.
- For taper spline-to-serration fittings
 - 1) Check that the splines and serrations are free from dust, burr, dents and indentations.
 - 2) Insert and align the splines and serrations by hand before press-fitting the shaft into the hole.
 - 3) If the spline-serration assembly is loose, disassemble and examine for wear. Replace worn parts with new ones.

3. O-RINGS

1. Handling

- 1) Discard any O-ring that has been in storage too long or has hardened.
- 2) Use only the O-rings prescribed for the part in the PARTS BOOK. This is especially important for those rings used with high-temperature engine parts, where heat-resistant and durable materials such as silicon are required.
- 3) ALWAYS USE NEW O-RINGS.

2. O-ring types

KOMATSU O-rings are marked with colored dots as shown in the accompanying chart.

Marking	Part Number	Material	Application
One blue spot	07000-0	Nitrile rubber	For low-pressure
Two blue spots	07000-1	Nitrile rubber	For high-pressure
One green spot	07000-3	Fluorine rubber	For low-pressure
Two green spots	07000-2	Fluorine rubber	For high-pressure
One red spot	07000-4	Nitrile rubber	For low-pressure in cold weather
Two red spots	07000-5	Nitrile rubber	For high-pressure in cold weather
Orange spot	07000-6	Silicon rubber	For low-pressure in hot weather

3. Inserting O-rings

After coating the O-ring with oil, insert carefully so as not to damage it. Silicon rubber O-rings require special care since they tear easily.

4. GASKETS

1. Handling gaskets

- 1) Always replace packings, gaskets and copper packings with new ones.
- 2) Make sure that there are no scratches or burr on the contact surfaces of the gasket.

2. Installing gaskets

- 1) Make sure that the holes in the gasket match those in the mating part.
- 2) Apply liquid gasket for the joints so specified in the SHOP MANUAL.

3. Precautions for using liquid gasket

- 1) Remove all scratches, dirt, paint, grease and old liquid gasket before applying a new coat.
- 2) Coat the specified area evenly and let dry for several minutes.
- 3) Assemble the mating parts when the liquid gasket is sticky to the touch.

5. BEARINGS

1. Handling bearings

- 1) Shield the bearings from dust and dirt; even the tiniest speck rapidly accelerates wear.
 - ★ Leave the bearings in their protective packaging until just before they are to be installed.
- 2) Protect a bearing from excessive force and shocks.
 - ★ Never dry a bearing with compressed air after cleaning.

2. Installing bearings

- 1) Never drive a bearing onto a shaft by pounding on the outer race or into an opening by pounding on the inner race. Such pounding produces dents in the tracks in the races.
- 2) When a bearing must be fitted onto a shaft with some interference, press-fit the inner race with the jig shown in the accompanying figure.

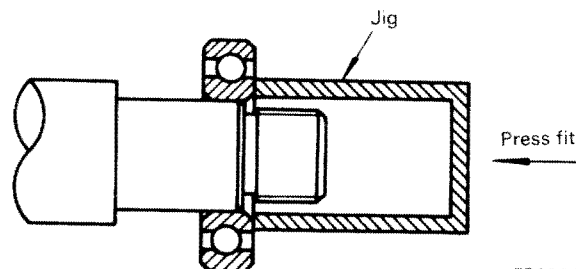

FS0039

ELECTRIC WIRE CODE

ELECTRIC

In the wiring diagrams, various colors and symbols are employed to indicate the thickness of wires.

This wire code table will help you understand WIRING DIAGRAMS.

Example: 05WB indicates a cable having a nominal number 05 and white coating with black stripe.

CLASSIFICATION BY THICKNESS

Nominal number	Copper wire			Cable O.D. (mm)	Current rating (A)	Applicable circuit
	Number strands	Dia. of strands (mm)	Cross section (mm ²)			
01	11	0.32	0.88	2.4	12	Starting, lighting, signal etc.
02	26	0.32	2.09	3.1	20	Lighting, signal etc.
05	65	0.32	5.23	4.6	37	Charging and signal
15	84	0.45	13.36	7.0	59	Starting (Glow plug)
40	85	0.80	42.73	11.4	135	Starting
60	127	0.80	63.84	13.6	178	Starting
100	217	0.80	109.1	17.6	230	Starting

CLASSIFICATION BY COLOR AND CODE

Priority	Circuits		Starting	Charging	Lighting	Signal	Instrument	Other
	Classification							
1	Primary	Code	B	W	R	G	Y	L
		Color	Black	White	Red	Green	Yellow	Blue
2	Auxillary	Code	BW	WR	RW	GW	YR	LW
		Color	Black & White	White & Red	Red & White	Green & White	Yellow & Red	Blue & White
3	Auxillary	Code	BY	WB	RB	GR	YB	LR
		Color	Black & Yellow	White & Black	Red & Black	Green & Red	Yellow & Black	Blue & Red
4	Auxillary	Code	BR	WL	RY	GY	YG	LY
		Color	Black & Red	White & Blue	Red & Yellow	Green & Yellow	Yellow & Green	Blue & Yellow
5	Auxillary	Code	—	WY	RG	GB	YL	LB
		Color	—	White & Yellow	Red & Green	Green & Black	Yellow & Blue	Blue
6	Auxillary	Code	—	WG	RL	GL	YW	
		Color	—	White & Green	Red & Blue	Green & Blue	Yellow & White	

TABLE OF LUBRICANT AND WATER QUANTITY

Reservoir	Kind of fluid	Capacity (ℓ)		Remarks
		Specified amount	Refill capacity	
Engine oil pan	Engine oil	71	67	SAE 30 <i>or</i> SAE 10W
Steering clutch case (incl. transmission, torque converter and bevel gear case)		185	136	
Final drive case		55 (each)	55 (each)	SAE 30
Recoil spring case		30	—	
Winch case	Engine oil or synthetic oil	125	100	SAE 10W
Counterweight tank	Engine oil or hydraulic oil	47	29	
Track roller	Gear oil or synthetic oil	0.78 – 0.90	—	GO140
Idler		0.48 – 0.55		
Carrier roller		0.64 – 0.74		
Fuel tank	Diesel fuel	480	—	ASTM D975 No. 2, No. 1
Cooling system	Water	175	—	Add antifreeze

- ★ The quantities of water, fuel, and lubrication oil listed above represent the supply of these required to fill the dry empty vessels up to the prescribed levels.
- ★ The oil for use should be selected depending upon the atmospheric temperature.
(Refer to the Operation and Maintenance Manual.)

ENGINE

12 TESTING AND ADJUSTING

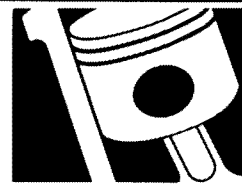

Standard valves for inspection and adjustment . . .	12- 2
Testing and adjusting tool list	12- 3
General inspections for engine inspection and adjustment	12- 4
Engine body	12- 8
Intake and exhaust system	12-11
Lubrication system	12-13
Fuel system	12-15
Cooling system	12-19

INTAKE AND EXHAUST SYSTEM

- Checking air cleaner element for clogging

1. Checking the dust indicator

Check whether the dust indicator (1) has reached the service level (red).

- ★ As the element becomes clogged, air intake resistance will increase. When this resistance reaches 635 mmAq of negative pressure, the dust indicator turns red.

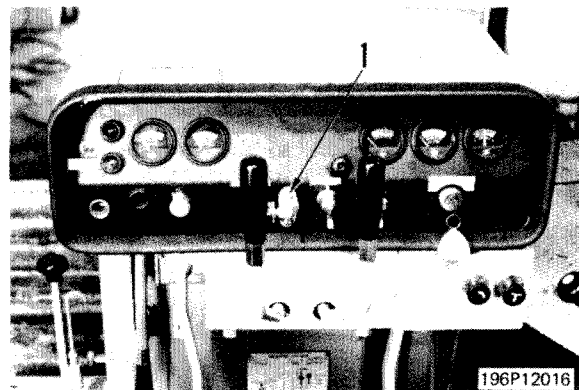

2. Checking the element

Whenever the dust indicator shows red or the exhaust fumes turn black, the element should be checked as follows:

- 1) Loosen the wing nut (2).
- 2) Pull out the outer element (3) and take out the inner element. Check them for clogging. If the elements are dirty or clogged, clean them.

- ★ After cleaning the element, press the indicator reset button to return the red piston to its original position.

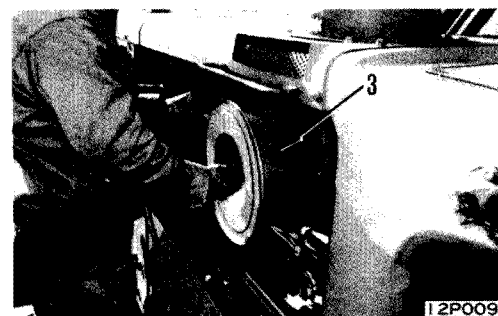
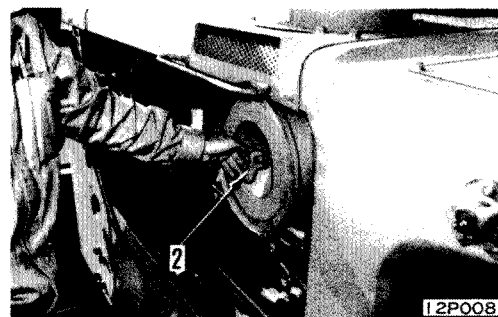

DISMOUNTING OF FAN BELT

1. Remove right and left engine side covers.
2. Loosen tension pulley adjustment nut (1) fully.
3. Push tension pulley (2) to remove all V-belts (3) from respective grooves in pulley.

 Be careful to prevent tension pulley from rotating when pushing it.

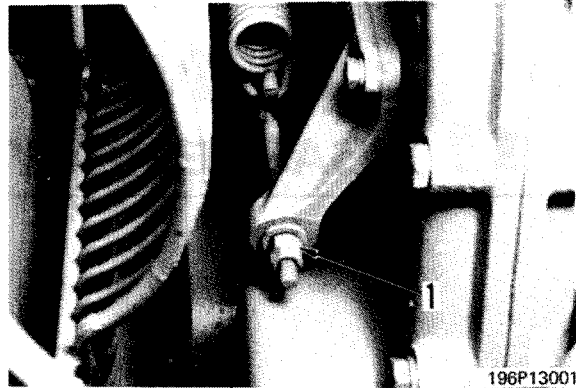

MOUNTING OF FAN BELT

1. Push tension pulley to install V-belts (3) in respective grooves in pulley.

 Be careful to prevent tension pulley from rotating when pushing it.

2. Tighten tension adjustment nut (1) until distance between bolt end to bracket is set to 30 ± 5 mm.
3. Install right and left engine side covers.

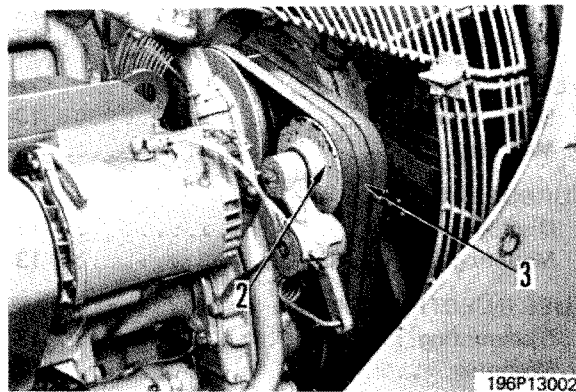

MOUNTING OF WATER PUMP ASSEMBLY

1. Fit O-ring in place and install water pump assembly (12).

 Mounting nut: 3.7 ± 0.6 kgm

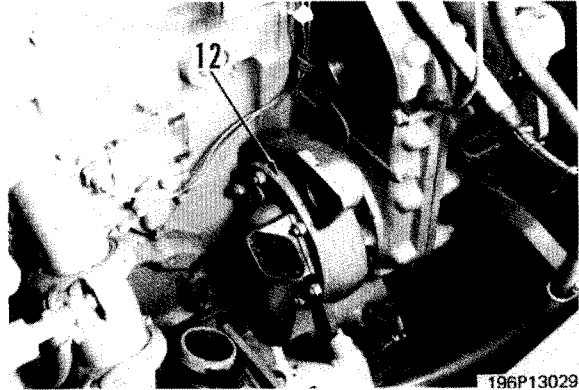

2. Piping

- 1) Fit gasket in place and connector water pump inlet tube (11).

 Gasket: Liquid gasket (LG-1)

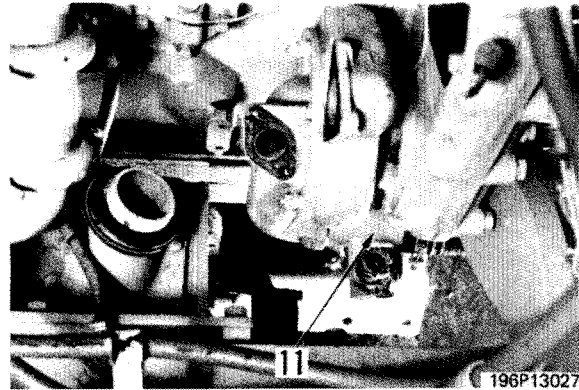

- 2) Fit gasket in place and install water pump outlet tube (8). Tighten clamp (7).

 Gasket: Liquid gasket (LG-1)

- 3) Connect corrosion resistor hose (6). With gasket in place, install bypass tube (5).

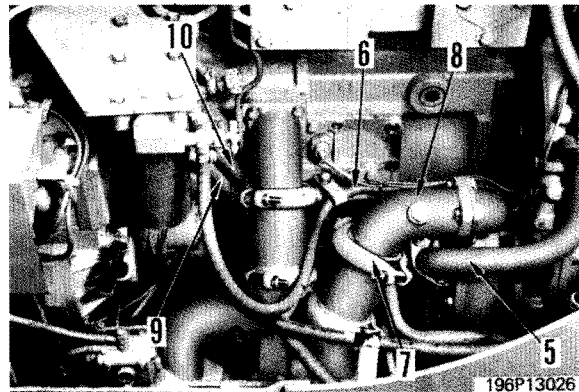

3. Water pump drive shaft

- 1) Install bracket (4).
- 2) Fit O-ring in place and install water pump drive shaft (3).

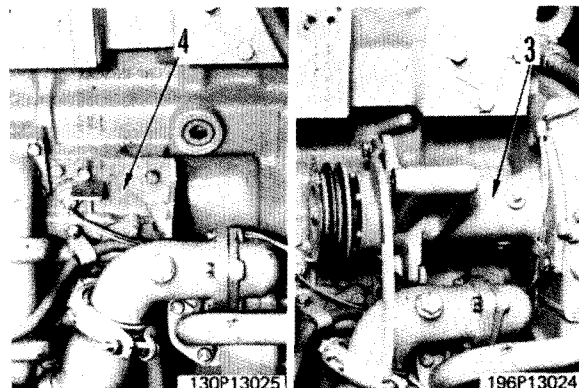

23. Crosshead, push rod and tappet

- 1) Remove crossheads (45).
- 2) Remove push rods (46).
- 3) Remove tappets (47).

★ Attach identification tags to removed parts so that they can be reinstalled in original positions.

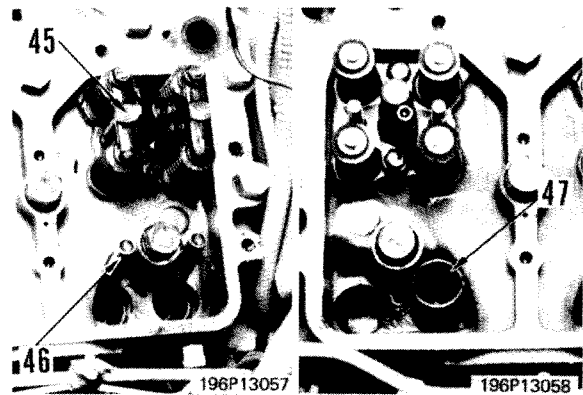
**24. Cylinder head assembly**

- 1) Remove 10 bolts (48) fastening cylinder head.

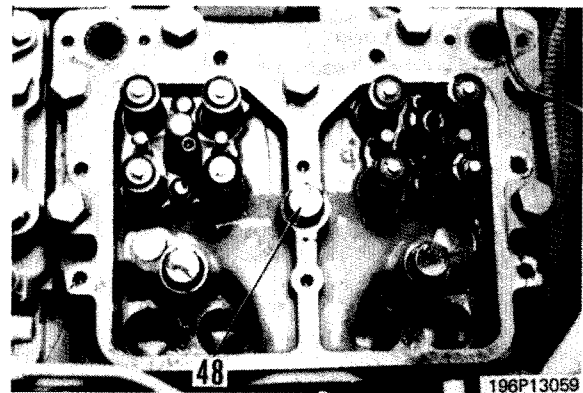

- 2) Attach eyebolts ② (12 mm, P = 1.75).
Sling cylinder head assembly (49) at eyebolts and lift it out.



Cylinder head assembly: 80 kg

- ★ Support cylinder head on blocks or lay it on its side to prevent its lower surface and nozzle holder tip from being damaged.

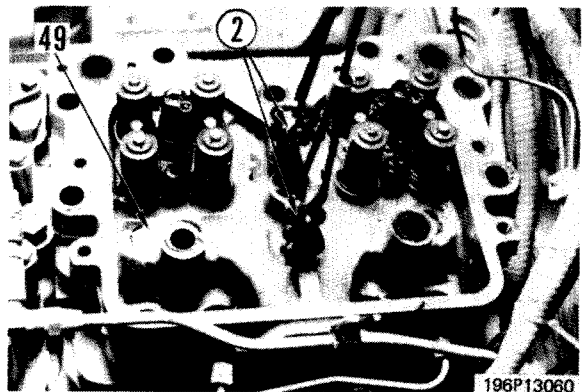

3. Hood

- 1) Disconnect ejector pipe (3).
- 2) Loosen clamp (4) fastening exhaust pipe. Remove exhaust pipe (5).
- 3) Unclamp and remove cover (6).

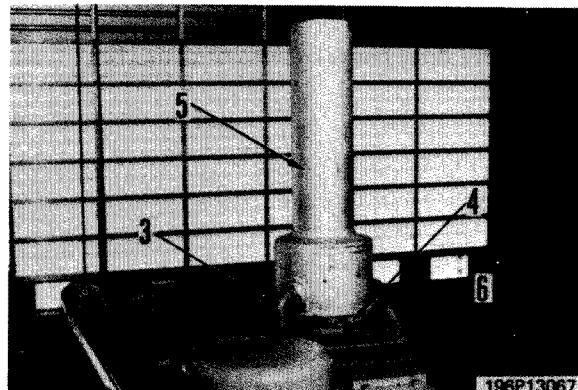

- 4) Remove right and left engine side covers.
- 5) Using sling tool (1), lift out hood (7).

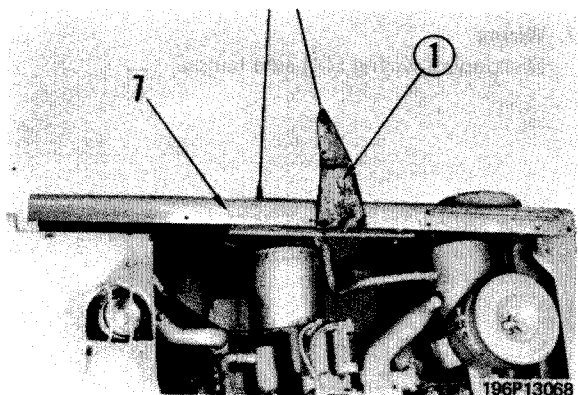
**4. Piping**

- 1) Disconnect radiator inlet tube (8).
- 2) Disconnect aeration hose (9).
- 3) Disconnect bypass tube (10).

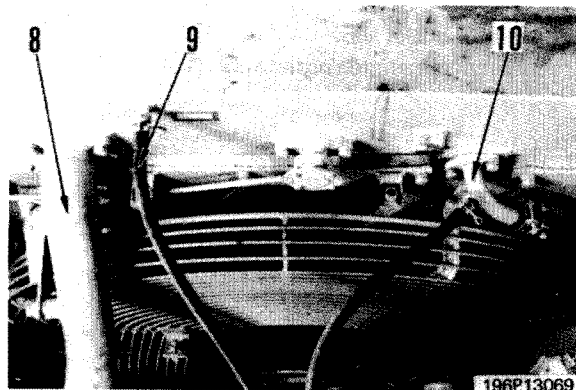
**5. Plate**

- Remove plate (11).

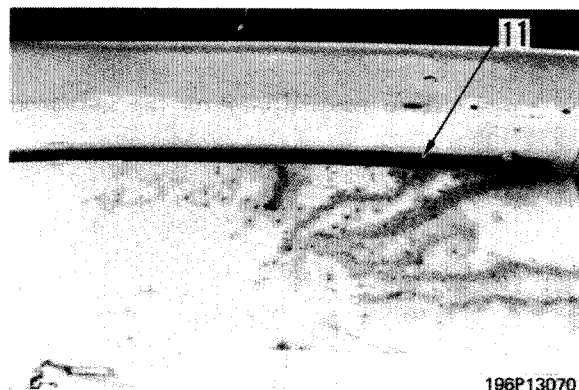

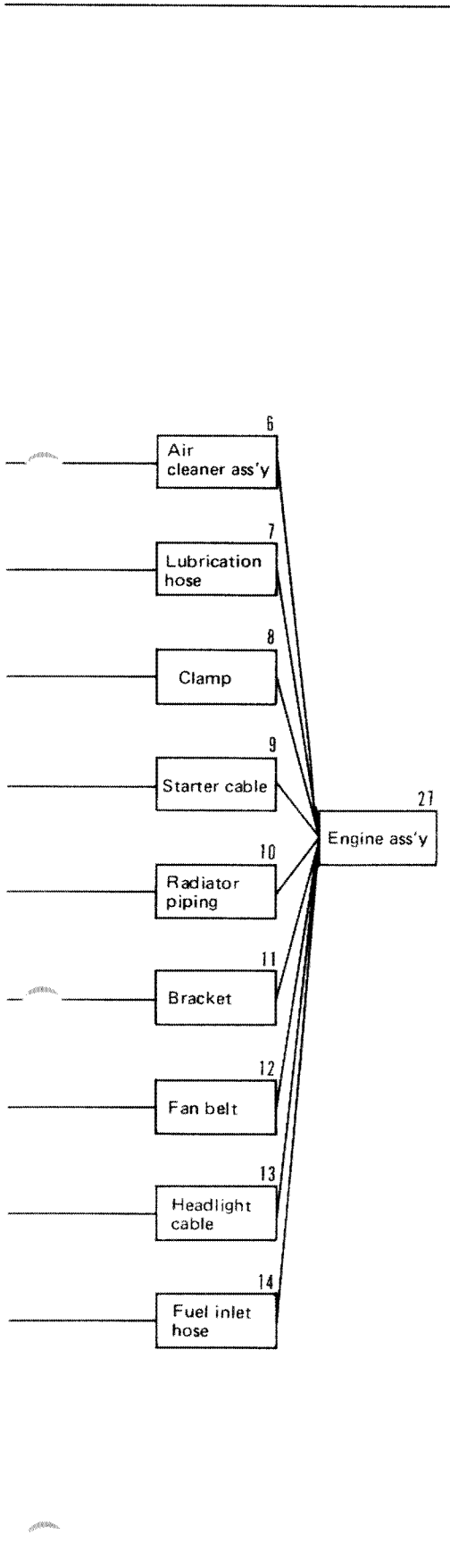

D155C-1

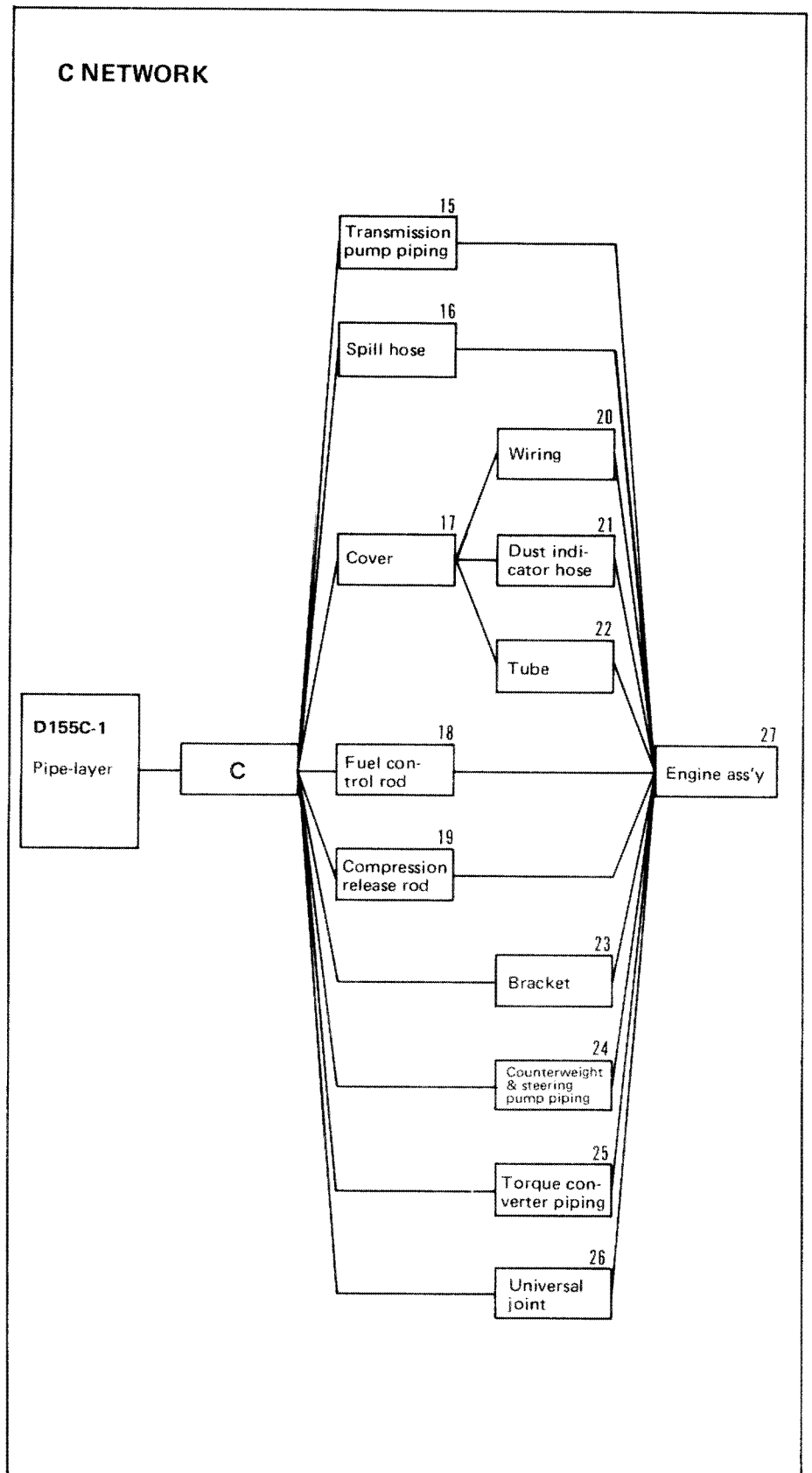

Special tool required

Part Number	Part Name	A
791-281-1000	Centering tool	1

1. Engine assembly

- 1) Install all mount shims in place (front and rear, left and right). Lift engine assembly (65) into position on frame.
 - ★ Lift engine into position gradually and carefully so as not to damage surroundings.
 - ★ Standard shim thickness: **2 mm**
(front and rear in common)
 - ★ Set intermediate joint between torque converter cooler and engine when positioning engine assembly.
- 2) Tighten front mounting bolts (63) and rear mounting bolts (64).
- 3) Set centering tool A on coupling of torque converter and transmission. Measure radial runout and face runout.
 - ★ Standard values:
 Radial runout should not exceed 0.5 mm
 Face runout should not exceed 0.5 mm
 - ★ If allowable limit is exceeded, loosen mounting bolts and adjust thickness of shims at each mount.
- 4) Lock front and rear mounting bolts with lock wires.

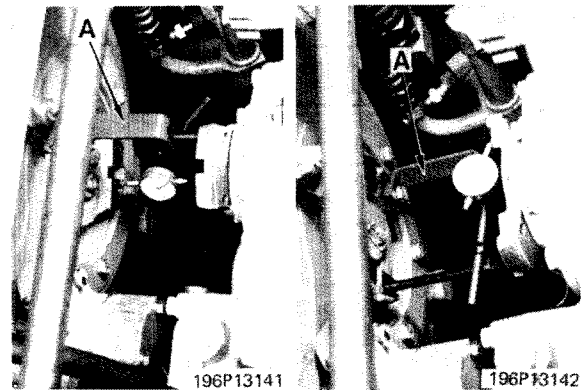
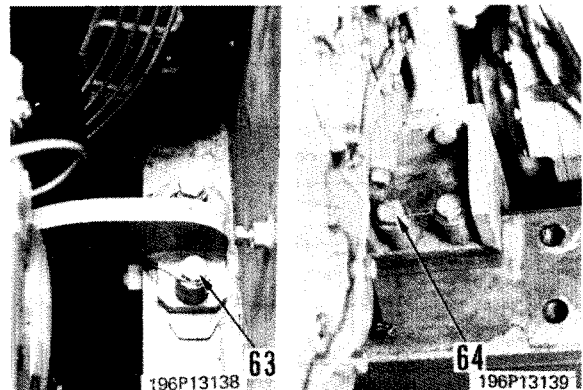
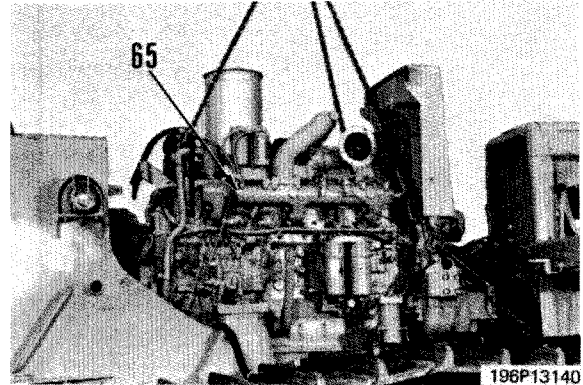

2. Universal joint

- 1) Lift universal joint (62) into position on coupling.
- 2) Tighten mounting bolts.

 Mounting bolt: 13 ± 0.4 kgm

- ★ After installation, apply grease (GLT2-LI) to universal joint.

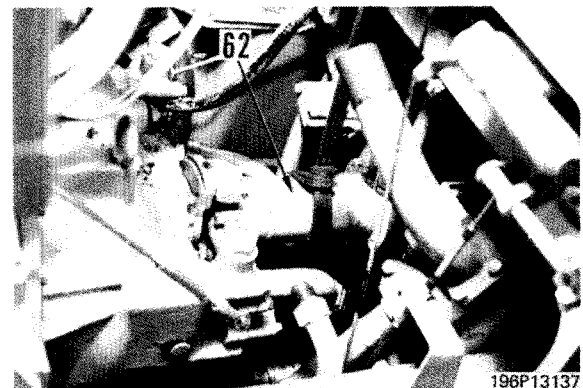

TORQUE CONVERTER TCS43C K4001 -

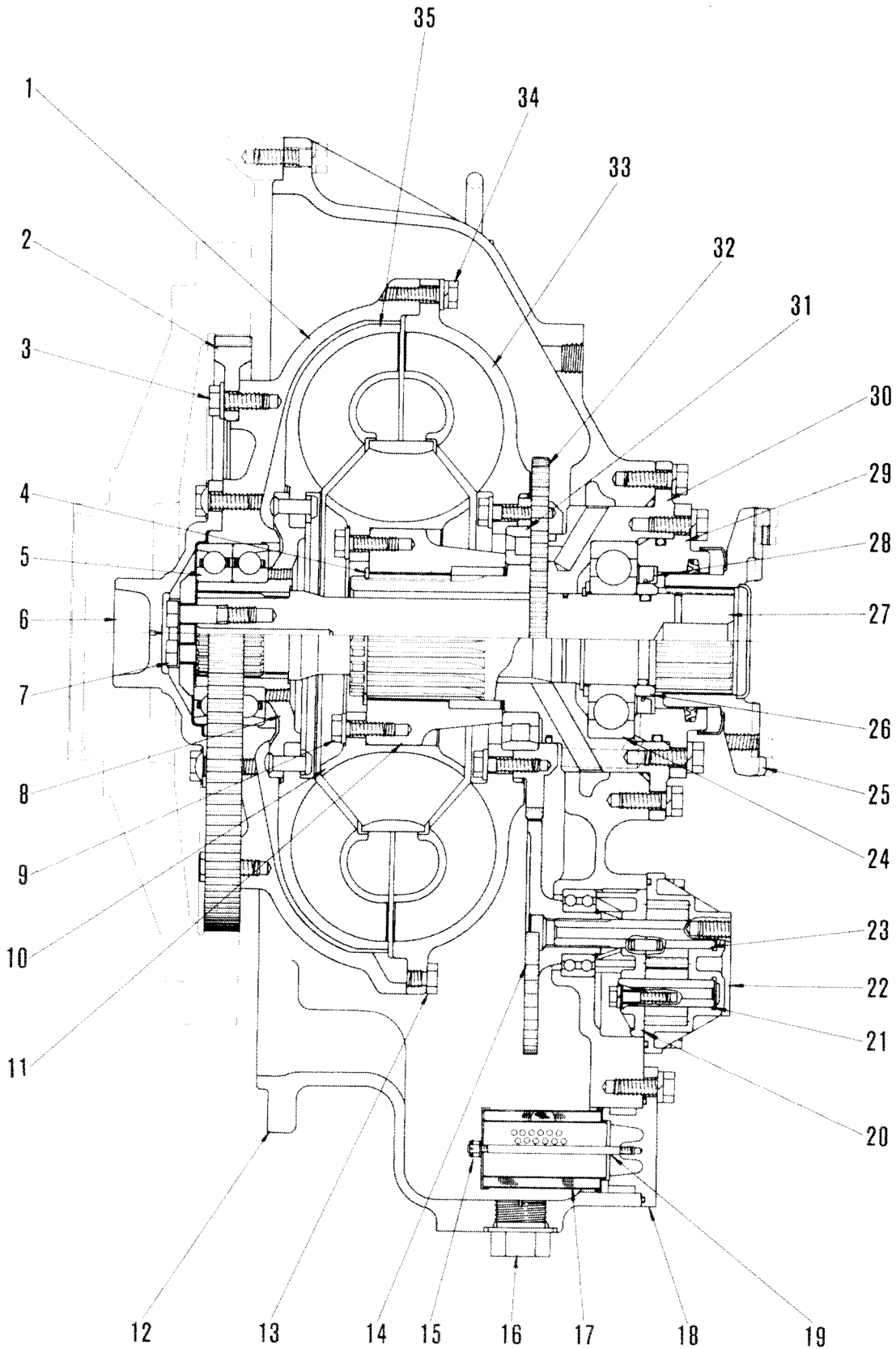

21F029

POWER TRANSMITTING LINE

FORWARD 1ST SPEED

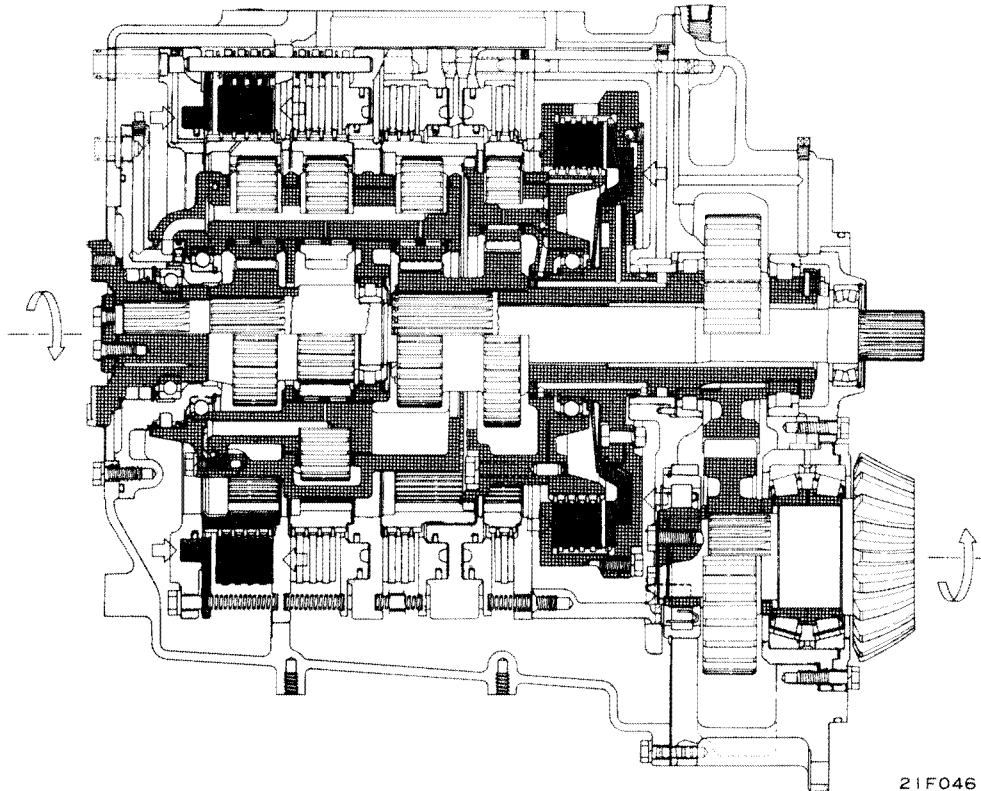

Engage No. 1 and No. 5 clutches, to lock No. 1 ring gear and to connect No. 5 gear directly with the output shaft (forming a unit with No. 4 carrier).

Torque is delivered from No. 1 sun gear A to No. 1 planetary pinion B.

As No. 1 ring gear C is locked No. 1 planetary pinion around No. 1 sun gear, thus No. 1 carrier (34) (forming a unit with No. 2, 3 carriers) transmits the torque in the same direction as that of No. 1 sun gear.

Engagement of No. 5 clutch brings No. 5 clutch drum (10), No. 5 gear (9), No. 5 carrier (26), and No. 3 ring gear J into engagement.

Torque of No. 1 carrier (forming a unit with No. 2, 3 carriers) drives No. 3, 4 sun gears, No. 5 clutch, No. 4 carrier, No. 3 ring gear, and the torque in the same direction as that of No. 1 gear is delivered to the output shaft (23).

The power transmitted from transfer drive gear O on the output shaft to transfer driven gear P is delivered to pinion gear Q as torque, opposite to the input direction.

SAFETY VALVE

Safety valve (25) is incorporated in the system between speed valve (28) and directional valve (23). It prevents the machine from moving if the engine is started with the gears engaged. (That is, if the driver has forgotten to put the gear lever in neutral.)

The gear lever must be put in neutral before the machine can move off.

A. Gear shift lever in neutral

Fluid from reducing valve (16) flowing through the speed valve displaces the safety valve completely when flowing through orifice e, thus completing the circuit of reducing valve → speed valve → directional valve.

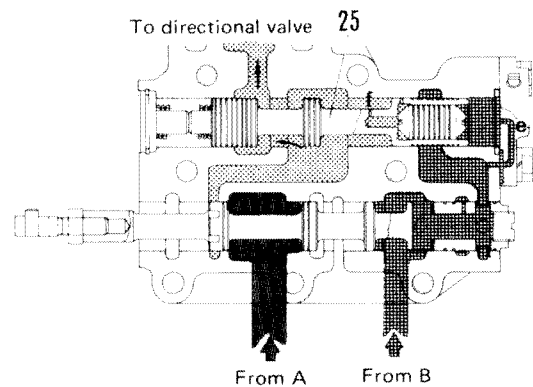

21F058

B. Gear shift lever then moved to engaged gears

Fluid from the reducing valve flows through the speed valve to the directional valve.

As the speed valve is shifted to any of the gear speeds, the fluid in the right section of the safety valve is discharged into the case through orifice e. However, the fluid flowing through the safety valve orifice f actuates piston (26) which slides to the right, thus the safety valve remains in position and the circuit to the directional valve is opened.

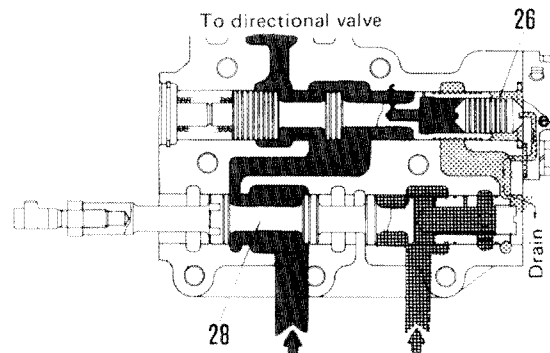

21F059

C. When the engine is started with the gear lever in any of the speed stages

When the gear lever engaged (that is, not in neutral), the reducing valve is not connected to orifice e. In this condition, the safety valve is not moved to the left even when the engine is started. Therefore, the circuit from the reducing valve to the directional valve remains closed and the machine cannot move. It is necessary to actuate the valve (that is, to shift to neutral as described under section A) before moving the gear lever again into any gear engaged position.

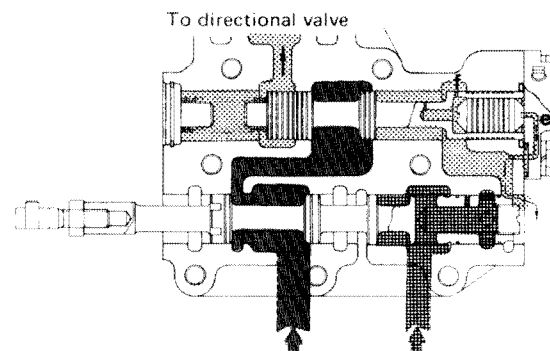

21F060

STEERING BRAKE HYDRAULIC CIRCUIT

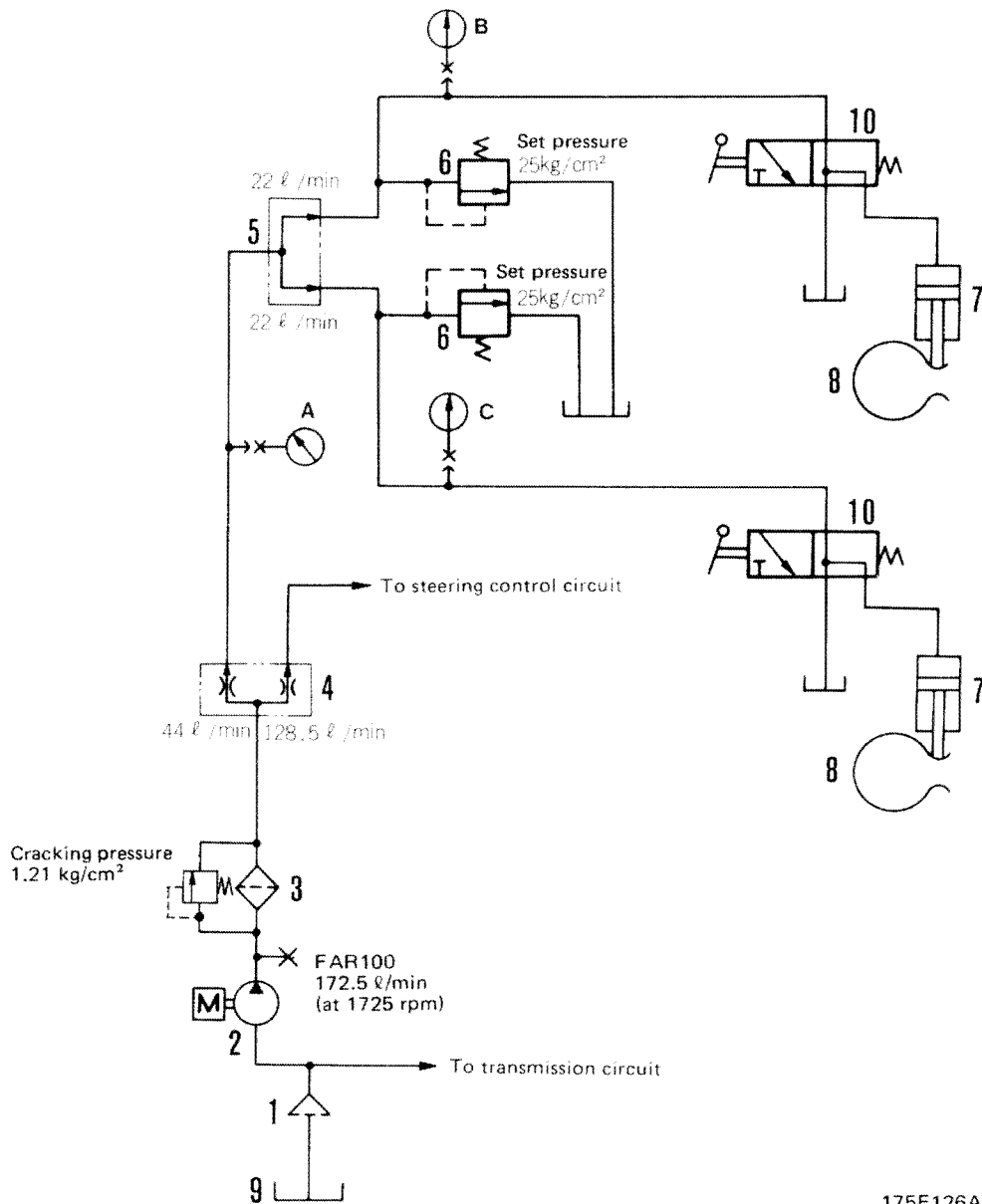

175F126A

- 1. Magnet strainer
- 2. Steering pump (FAR100)
- 3. Steering filter
- 4. Flow divider
- 5. Flow divider
- 6. Brake relief valve
- 7. Brake booster

- 8. Steering brake
- 9. Steering case
- 10. Spool
- A. Plug for brake booster pressure (PT1/8)
- B. Plug for right brake pressure (PT1/8)
- C. Plug for left brake pressure (PT1/8)

CLICK HERE TO **DOWNLOAD** THE COMPLETE MANUAL

- Thank you very much for reading the preview of the manual.
- You can download the complete manual from: www.heydownloads.com by clicking the link below



- Please note: If there is no response to CLICKING the link, please download this PDF first and then click on it.

CLICK HERE TO **DOWNLOAD** THE COMPLETE MANUAL

STEERING PUMP

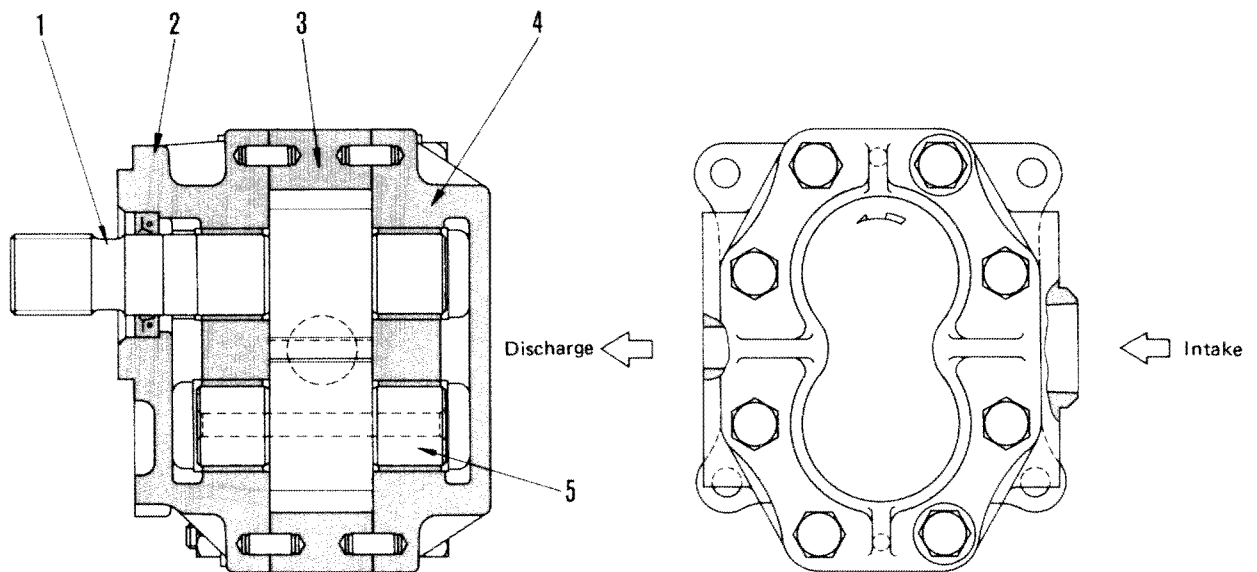

21F116

1. Drive gear
2. Bracket
3. Gear case
4. Housing
5. Driven gear

Pump type: FAR100
Flow: 172.5 ℓ/min. (at 1735 rpm)

2) Relief valve, regulator valve

Regulator valve

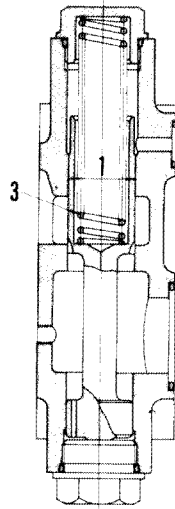

24F009

Relief valve

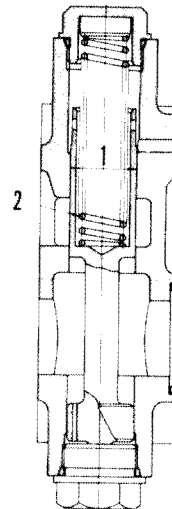

24F010

Unit: mm

No.	Check item	Criteria				Remedy	
1	Clearance between valve body and spool	Standard size	Tolerance		Standard clearance	Clearance limit	
			Shaft	Hole			
		32	-0.050 -0.066	+0.025 0	0.050 — 0.091	0.20	
2	Relief valve spring	Standard size			Repair limit		Replace
		Free length x O.D.	Installed length	Installed load	Free length	Load	
	137.7 x 24	98.0	63.5 kg	134.2	57.9 kg		
	Relief valve setting pressure	8.7 ^{+0.3} / ₀ kg/cm ² Oil temperature 75 ± 5°C					
3	Regulator valve spring	Standard size			Repair limit		
		Free length x O.D.	Installed length	Installed load	Free length	Load	
	126.6 x 23.5	106.5	20.9 kg	120	14.0 kg		
	Regulator valve setting pressure	2.5 ± 1.0 kg/cm ² at 60 ℓ/min. 3.5 ± 0.5 kg/cm ² at 100 ℓ/min. Oil temperature 75 ± 5°C 4.5 ± 0.5 kg/cm ² at 200 ℓ/min.					

Unit: mm

No.	Check item	Criteria					Remedy
1	Thickness of brake lining	Standard size			Repair limit		
		15.5			11.5		
2	Clearance between booster piston and booster housing	Standard size	Tolerance		Standard clearance	Clearance limit	Replace
			Shaft	Hole			
3	Clearance between booster spool and sleeve	25	-0.005 -0.010	+0.064 +0.034	0.039 – 0.074	0.1	
4	Booster spool return spring	Standard size			Repair limit		
		Free length x O.D.	Installed length	Installed load	Free length	Load	
		89.0 x	58.0	10.0 kg			
5	Brake band return spring	78.3 x 23.2	97.0	20.0 kg	82.0	16.0 kg	
6	Brake band leaf spring	42.4 x 18.3	47.4	4.54 kg	43.4	3.6 kg	
7	Rod connecting nut tightening torque	25.5 ± 3 kgm					Retighten
8	Return spring hook tightening torque	2.9 ± 0.6 kgm					

RECOIL SPRING

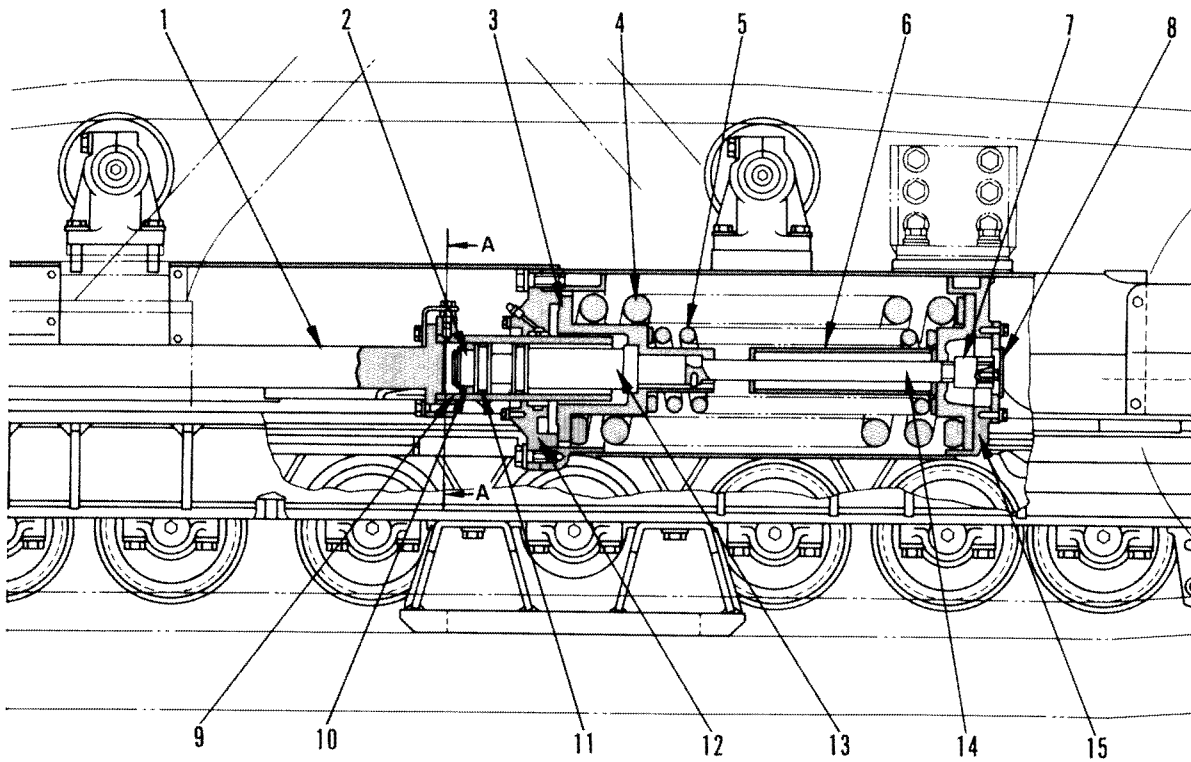
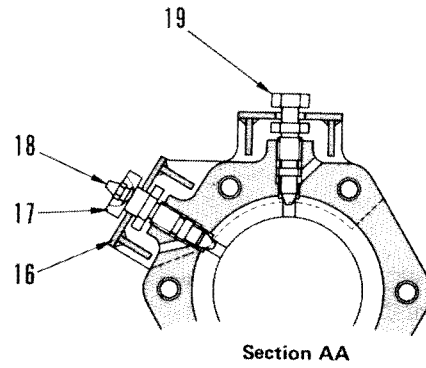

F176A025

- | | |
|--------------------------|--------------------|
| 1. Rod | 11. Piston ring |
| 2. Piston | 12. Front cover |
| 3. Front pilot | 13. Spacer |
| 4. Recoil spring (large) | 14. Bolt |
| 5. Recoil spring (small) | 15. Rear pilot |
| 6. Sleeve | 16. Stopper |
| 7. Nut | 17. Lubricator |
| 8. Cover | 18. Grease fitting |
| 9. Cylinder | 19. Plug |
| 10. Packing | |

Unit: mm

No.	Check Item	Criteria				Remedy	
		Standard size	Tolerance		Repair limit		
1	Outside diameter of outer flange	298				Rebuild or replace	
		282					
2	Outside diameter of inner flange	255			230		
3	Outside diameter of tread	292					
4	Total width	65			74		
5	Width of tread (single flange)	62			80		
6	Width of tread (double flange)	24			15		
7	Width of flange (single flange)	24			15		
8	Width of flange (double flange, outer)	22			13		
9	Width of flange (double flange, inner)	20			19		
10	Shaft collar width	85	Tolerance		Standard clearance 0.43 – 0.515	Clearance limit 1.5	
			Shaft	Hole			
11	Clearance between shaft and bushing	135	-0.210 -0.260	+0.255 +0.220	0.017 – 0.130	0.30	Replace
12	Interference between roller and outer bushing		+0.130 +0.080	+0.063 0			
13	Shaft play in axial direction	Standard clearance		Clearance limit			
		0.50 – 0.76		1.5			
14	Track roller mounting bolt tightening torque	94 ± 10 kgm				Adjust	
15	Oil filler plug tightening torque	21 ± 5 kgm					

SAFETY DEVICES

To prepare for any possible misoperation or to prevent misoperation during a job, the following devices are provided:

1. Boom upper limit automatic stopper (Kick-out).
2. Hook overwinding alarm device.
3. Boom rake gauge.

(1) How to adjust the kick-out

When the boom is overwound, the boom lever will function to force the boom to return to the position "N". The kick-out force at the boom top shown as C in Fig. must be 9.75 kg.

	E Spring	D Spring
Mounting load	99.9 kg	2000 ± 160 kg
Mounting height	126 mm	525 mm
Free height	164 mm	613 mm

If the dimension B in the Fig. is adjusted 25 mm, the kick-out force will be 9.75 kg.

Note: Pay careful attention to spring removal so that spring force does not cause nuts, etc. to be scattered.

Item		Condition	Standard	Remarks	
Performance	Work equipment	<ul style="list-style-type: none"> Hook 	<ul style="list-style-type: none"> At 800 rpm of engine speed, measure the number of times of lever operation required to raise or lower load 30 cm and compute inching (movement of load for each lever operation). Vertical Weight of load: 4 – 7.5 ton Oil temperature: 65° ± 5°C 	3 max.	
		[Working condition] <ul style="list-style-type: none"> Boom & hook 	<ul style="list-style-type: none"> Check for normal working condition of boom and hook by varying engine speed (slow ↔ full). Weight of load: 4 – 7.5 ton 	No jolting allowed	
		[Free-fall characteristic] <ul style="list-style-type: none"> Free-fall operation 	<ul style="list-style-type: none"> Apply 200 kg of load to hook and check for possibility of free fall. 	Free fall must be possible	
		<ul style="list-style-type: none"> Operation of electromagnetic valve 	<ul style="list-style-type: none"> During above-mentioned testing, measure valve outlet pressure to confirm that electromagnetic valve is closed completely. 		
		Free-fall brake characteristic	<ul style="list-style-type: none"> Apply 15 ton of load to hook and, after allowing 30 cm free falling, place the lever in HOLD position to check for stopping of free fall. Counterweight expansion and working radius should not exceed 3.5 m. 	Free fall must be stopped positively	
		[Spontaneous lowering] <ul style="list-style-type: none"> Boom Hook 	<ul style="list-style-type: none"> Weight of load: 15 ton Working radius: 3.5 ± 0.5 m Oil temperature: 80° ± 5°C Leave engine stopped for 60 minutes before testing. 	0 mm	

- 3) Remove right and left plates (21).
 ★ Mark right and left plates before removal to prevent confusion between them.
- 4) Pull out right and left camshafts (22) from case (23).
 ★ Mark right and left camshafts before removal to prevent confusion between them.

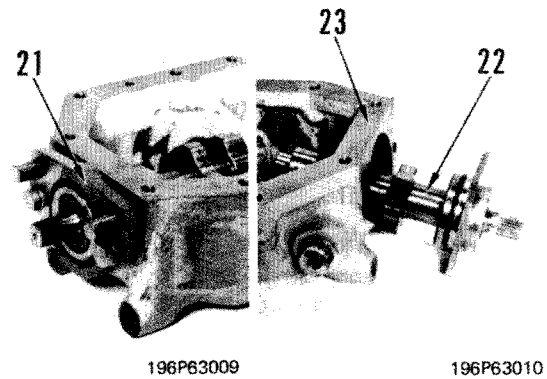

- 5) When disassembling each camshaft assembly, use the following procedure:
- Pry snap ring (24) off and pull out camshaft (25).
 - Pry snap ring (26) and remove bearing (27).
 - Remove oil seal (28) from cage (29).

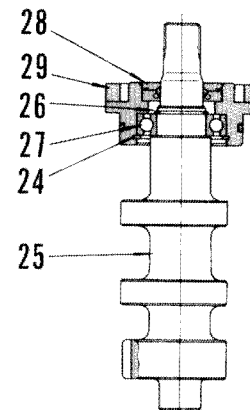

- 6) Remove notch (30) and spring (31).
- 7) Remove bolts fastening gland assembly (32) to case (23). Remove gland assembly by using jack bolts (10 mm, P = 1.5).

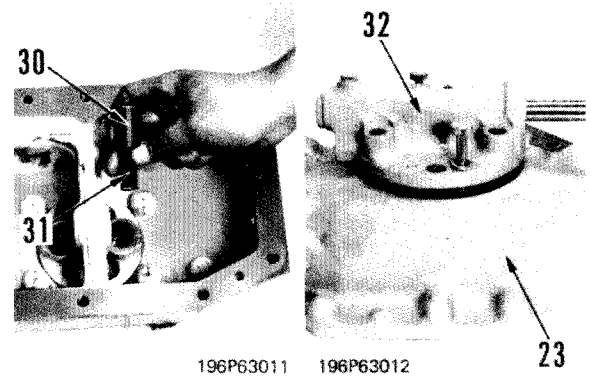

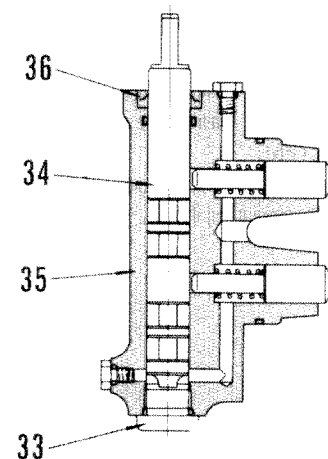

- 8) When disassembling gland assembly, use the following procedure:
- Remove plug (33) and pull out spool (34).
 - Remove seal (36) from gland (35).



DISMOUNTING OF COUNTERWEIGHT PUMP ASSEMBLY

 Be sure to keep counterweight lowered completely.

1.  Loosen oil filler cap gradually to release the inner pressure from hydraulic tank.
Remove drain plug (1) to drain oil from hydraulic tank.

 Hydraulic tank: **Approx. 28 ℓ**

2. Remove floor plate.
3. Detach intermediate hose (2) from counterweight cylinder piping.
4. Detach starting engine rod (3) and remove bracket (4).
5. Detach pump inlet tube (5) and disconnect outlet tube (6).
6. Lift off counterweight pump assembly (7).

 Counterweight pump assembly: **25 kg**

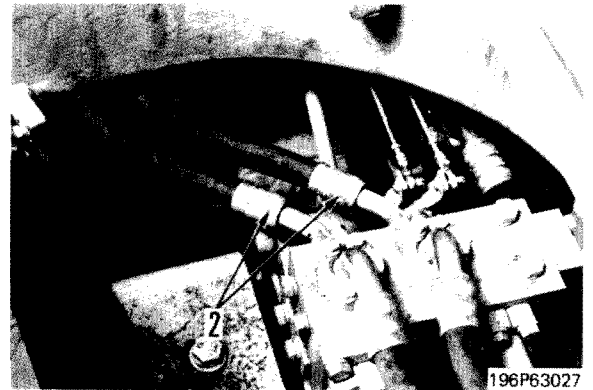
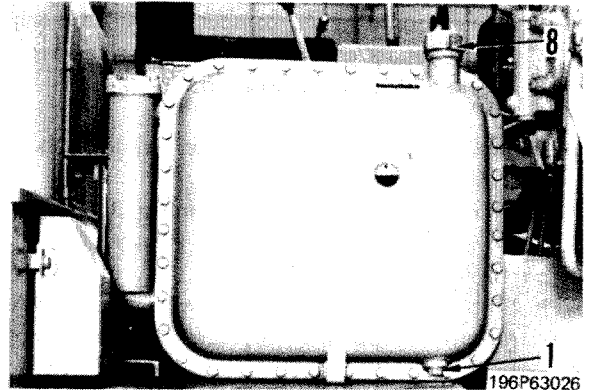

MOUNTING OF COUNTERWEIGHT PUMP ASSEMBLY

1. Attach O-ring to housing. Lift counterweight pump assembly (7) into position so that its spline meshes with that of housing.
2. Attach O-ring, connect outlet tube (6), and install inlet tube (5).
3. Install bracket (4) and connect starting engine rod (3).
★ Be sure to bend cotter pin securely.
4. Attach O-rings and connect intermediate hose (2) to counterweight cylinder piping.
5. Install floor plate.
6. Install drain plug (1) and refill hydraulic tank with oil through oil filler (8) up to specified level.

 Hydraulic tank: **Approx. 28 ℓ**

- ★ Recheck oil level after running the engine to allow oil to circulate in piping.

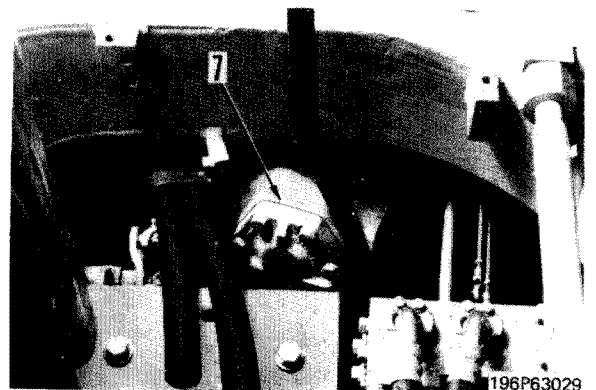
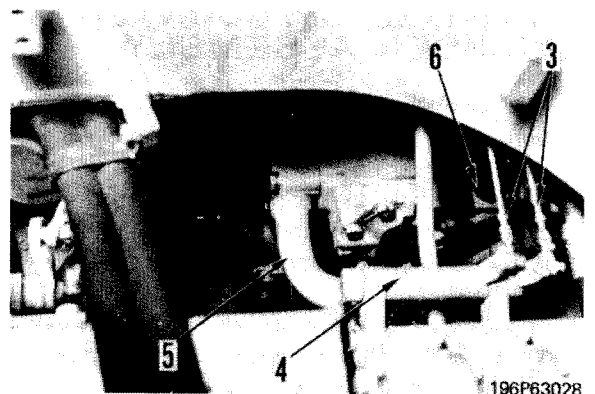

- **Assembly of Check valve**

4. Install check valve (24) and spring (23) to body. Attach O-ring and fit check valve seat (22) to body.
5. Install plate (21).

- **Assembly of Main relief valve assembly**

6. Insert spring (18) and poppet (17) into valve body (19). Install seat (16), to which O-ring is attached, to valve body.
7. Install valve (14) in housing. Then install spring (15) in housing.
8. Put valve body and housing together to form main relief valve assembly (12). Attach O-ring to the assembly and position the assembly on body.
9. Install and tighten mounting bolts (11).

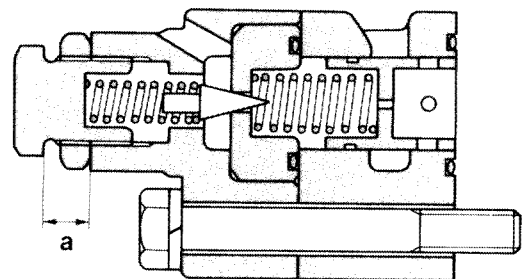

 Mounting bolt: 10 ± 1 kgm

- ★ If readjustment of plug (20) is necessary, set it to the same length "a" as before disassembly and lock it to that position with nut (38).
- ★ Standard of length "a" is
- ★ Oil pressure varies for each turn of plug.
- ★ For details of oil pressure adjustment, see ADJUSTMENT OF MAIN RELIEF VALVE in Inspection and Adjustment section.



- **Assembly of Suction valve assembly**

10. Install valve (10), spring (9) and spring seat (8) in that order into collar (7). Install collar, on which O-ring is fitted, to housing (39).
11. Install plate (6).
12. Install valve (5) and spring (4) to body. Attach O-ring to plate (3) and install plate to body.
13. Attach O-rings to suction valve assembly (2) and install the assembly to body (21) with mounting bolts (1).

 Mounting bolt: 

5. High Position of the Hi-Low Lever and Boom Raise · Hook Lower Operation

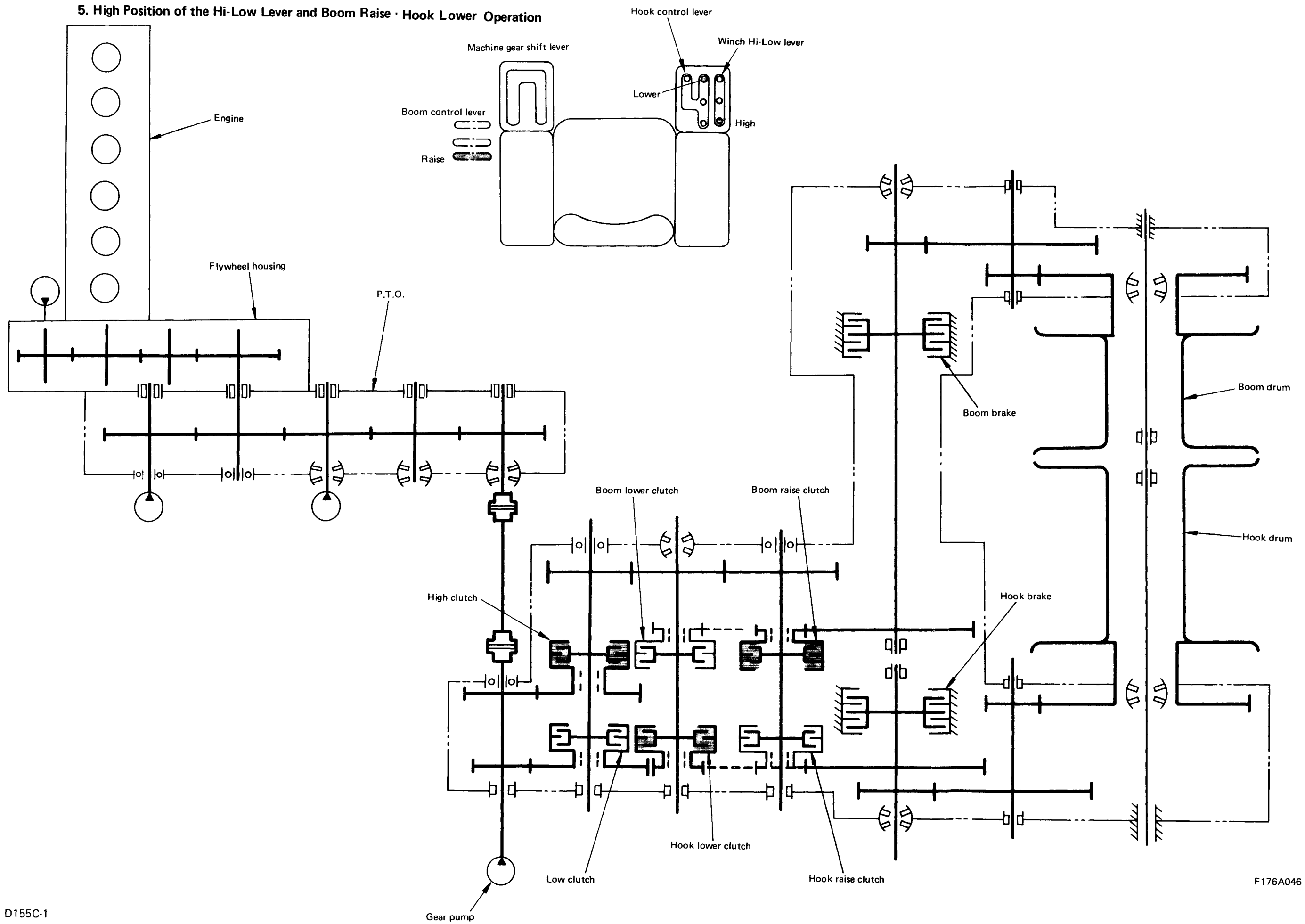

3. Link

Sling right or left link (5), pull out joint pin, and lift off the link. Remove the opposite link in the same way.

 Link: 75 kg

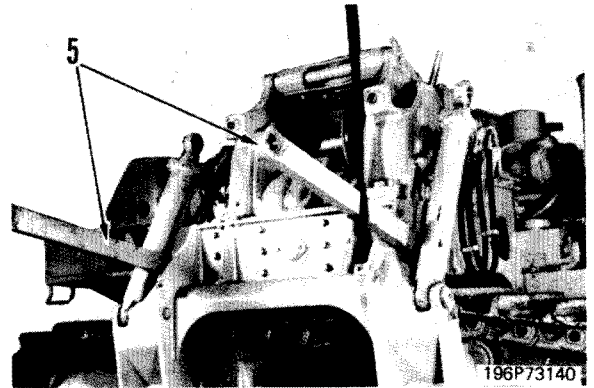
**4. Cylinder assembly**

 Move control lever two or three times to expel the remaining pressure from piping.

- 1) Disconnect cylinder inlet and outlet pipes (7) and (8).
- 2) Sling cylinder assembly (4), pull out joint pin, and lift off cylinder assembly. Remove the opposite cylinder assembly in the same way.

 Cylinder assembly: 70 kg

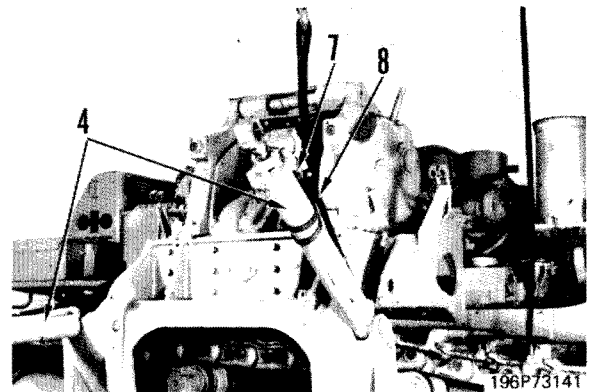
**5. Link**

Sling right or left link (6), pull out joint pin, and lift off the link. Remove the opposite link in the same way.

 Link: 1000 kg

- ★ Identify the right and left links to prevent confusion.

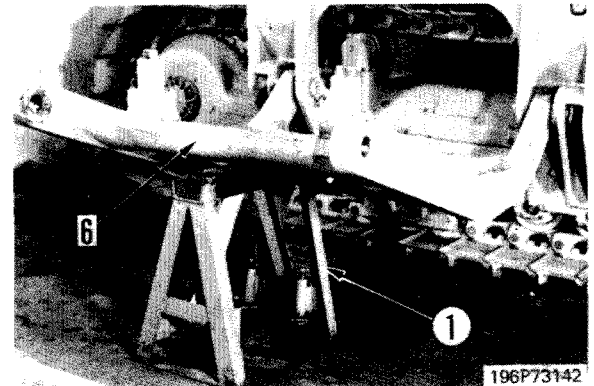
**6. Frame**

- 1) Sling frame (9).
- 2) Remove upper and lower mounting bolts (1) and lift off frame.

 Frame: 850 kg

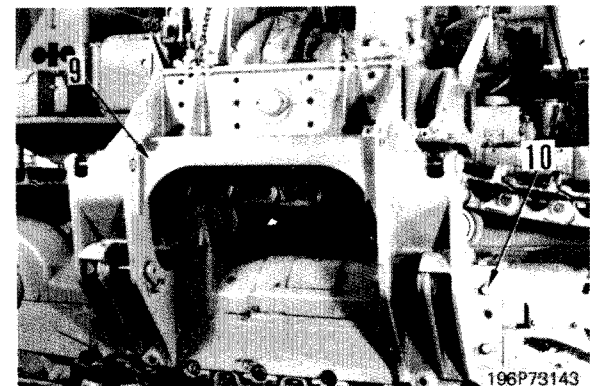

4. Filter

Remove filter assembly (4).

5. Selector valve assembly

- 1) Detach flow divider and remove selector valve assembly (6).
- 2) Remove bracket (7).

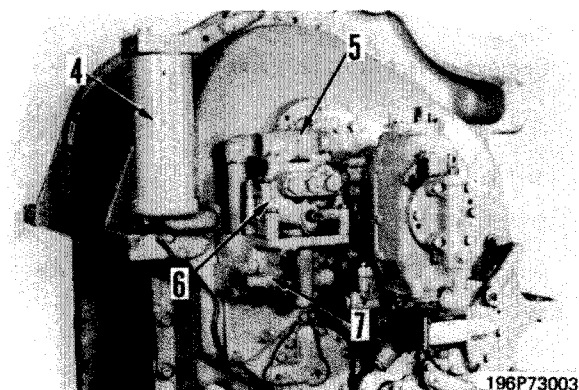
**6. Winch control valve assembly**

- 1) Sling winch control valve assembly (8).
- 2) Remove eight mounting bolts (9) and lift off winch control valve assembly.

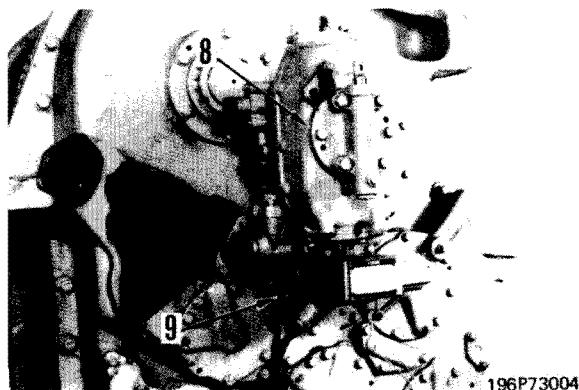

Control valve assembly: 100 kg

**7. Winch pump assembly**

Remove winch pump assembly (10).

8. Cover

Remove covers (11), (12), (13), (14), (15), (16), (17) and (18).

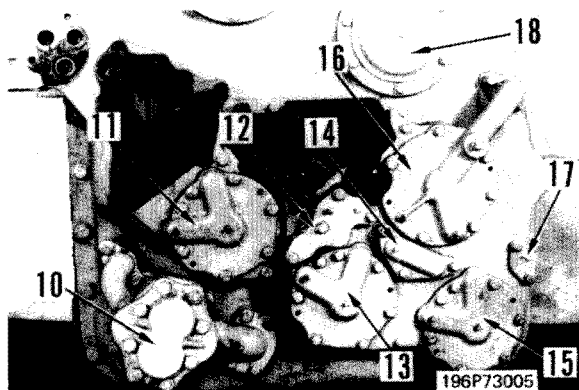
**9. Seat**

Turn in guide bolts ① (10 mm, P = 1.5), remove mounting bolts, and take out seats (19) and (20).



- 2) Sling HI clutch assembly (100) and put a pipe (55 mm I.D.) against it.
- 3) Pull out shaft using puller (4) and lift off clutch assembly.

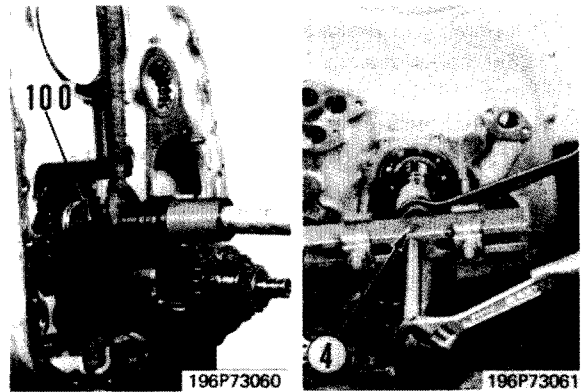

- 4) Similarly, remove BOOM UP/HOOK UP clutch assembly (101) and BOOM DOWN/HOOK DOWN clutch assembly (102).

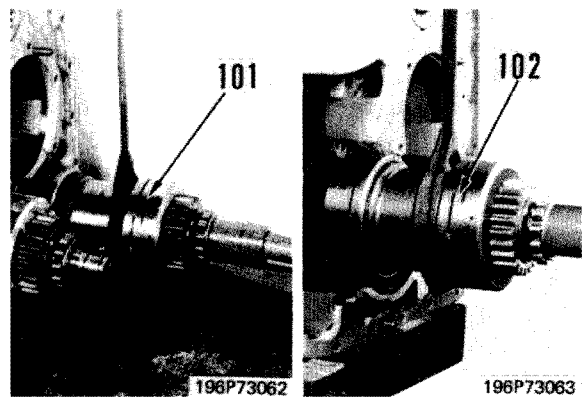

2. Clutch assembly

- 1) Sling BOOM DOWN/HOOK DOWN clutch assembly (102) and keep it horizontal by using a pipe (55 mm I.D.). Set the assembly to bearing.

★ When inserting clutch assembly into case, be careful not to allow drum teeth to get out of alignment with disc teeth.

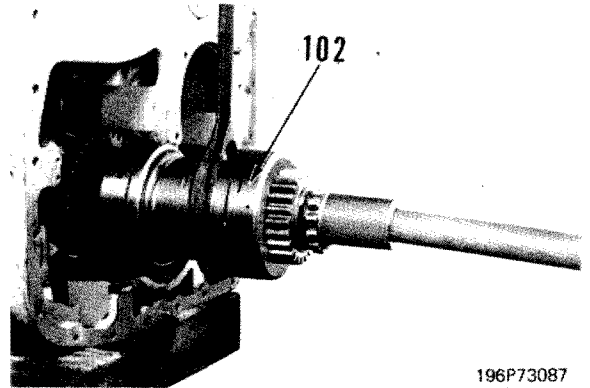

196P73087

- 2) Put puller (4) against bearing inner race to prevent it from coming out of case.
- 3) Keeping clutch assembly horizontal, press-fit its shaft into bearing with puller (8) and special tool F.

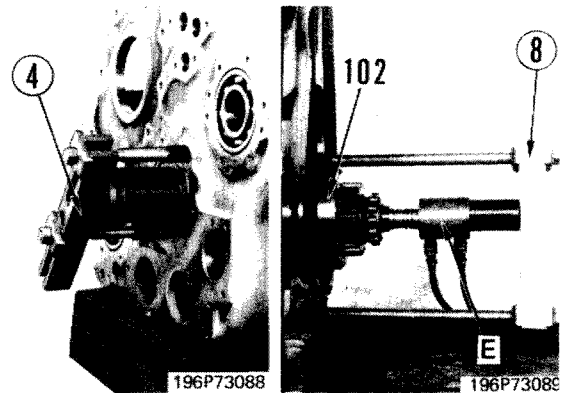

196P73088

196P73088

- 4) Similarly, install BOOM UP/HOOK UP clutch assembly (101) and HI clutch assembly (100).

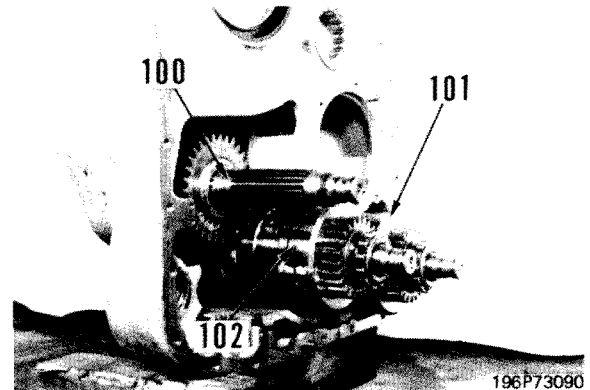

196P73090

- 5) Install lock plates and tighten nuts (99), (98) and (97) temporarily.

★ These nuts are retightened later.

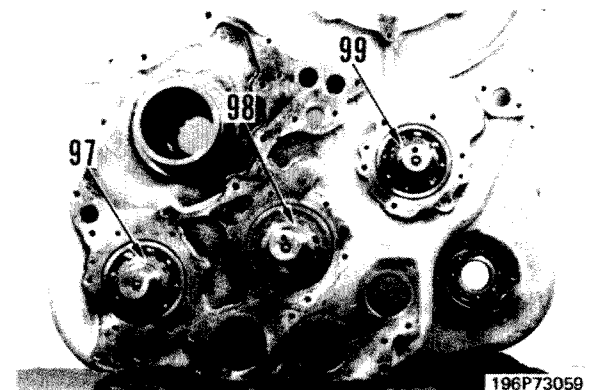

196P73059

- 3) Attach O-ring. Sling intermediate case (45) horizontally using eyebolts ① (16 mm, P = 2.0) and position the case on boom drum.

 Oil seal lip: Fill 40 to 60% of vacancy with grease (GLT2-LI)

- 4) Install mounting bolts.

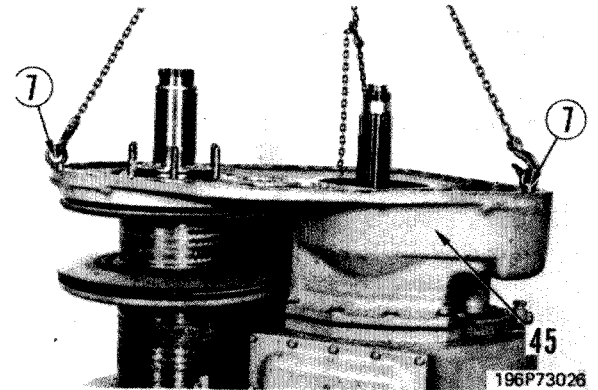

23. Gear assembly

- 1) Using push tool (215 mm O.D.), press-fit bearing (145) into gear (146).
- 2) Using push tool (180 mm O.D.), press-fit oil seal (147) into gear (146).

 Oil seal lip: Fill 40 to 60% of vacancy with grease (GLT2-LI)

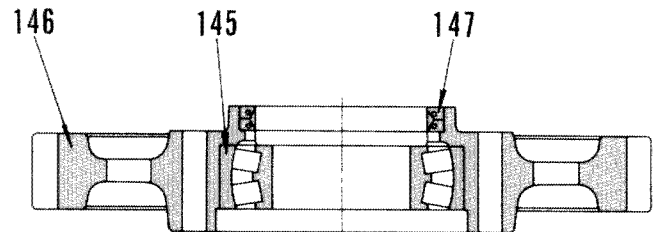

- 3) Attach O-ring to boom drum.
- 4) Lift gear assembly (44) into position on drum shaft so that dowel pins come into alignment with pin holes.
- 5) Using special tool E, press-fit the gear assembly.

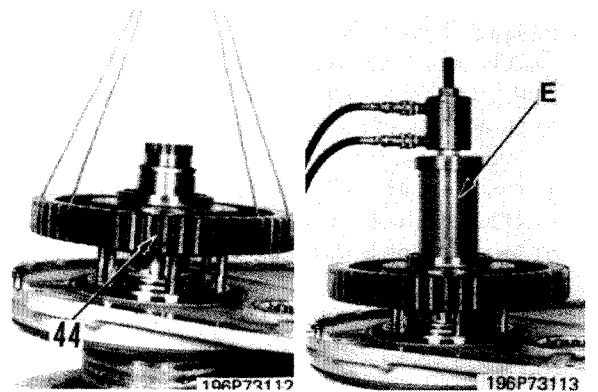

- 6) Install mounting bolts (43).
 - ★ Be sure to bend lock plates securely.

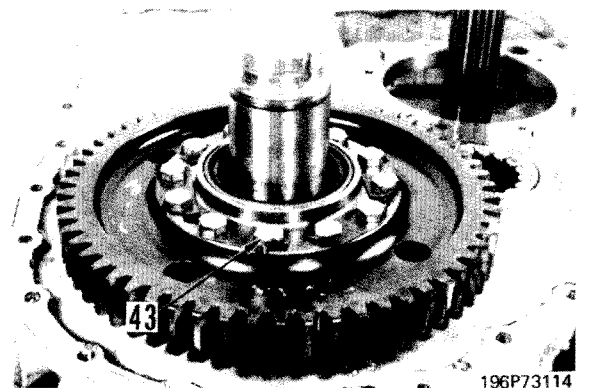

COUNTERWEIGHT

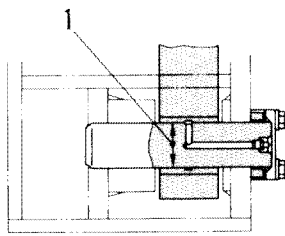
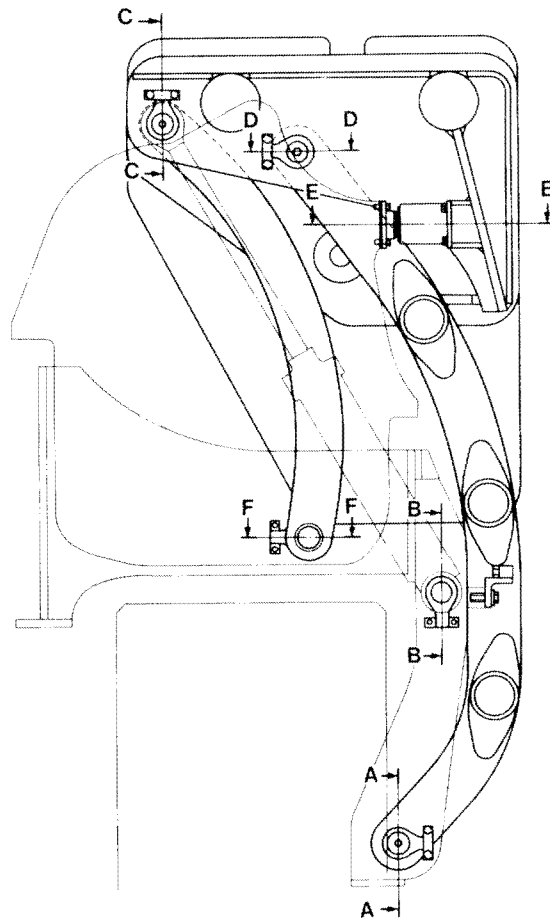

Section A-A

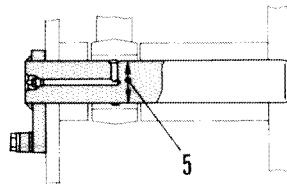

Section B-B

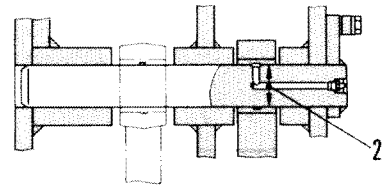

Section C-C

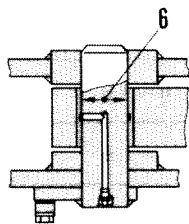

Section D-D

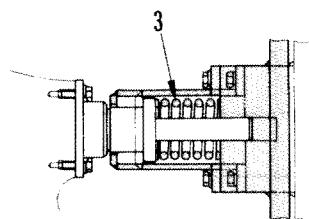

Section E-E

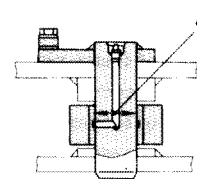

Section F-F

F176A051

CLICK HERE TO **DOWNLOAD** THE COMPLETE MANUAL

- Thank you very much for reading the preview of the manual.
- You can download the complete manual from: www.heydownloads.com by clicking the link below



- Please note: If there is no response to CLICKING the link, please download this PDF first and then click on it.

CLICK HERE TO **DOWNLOAD** THE COMPLETE MANUAL