

Shop Manual

930E-4SE

DUMP TRUCK

SERIAL NUMBERS **A30727 - A30756**

KOMATSU[®]

CLICK HERE TO **DOWNLOAD** THE COMPLETE MANUAL

- Thank you very much for reading the preview of the manual.
- You can download the complete manual from: www.heydownloads.com by clicking the link below



- Please note: If there is no response to CLICKING the link, please download this PDF first and then click on it.

CLICK HERE TO **DOWNLOAD** THE COMPLETE MANUAL

SPECIFICATIONS

These specifications are for the standard Komatsu 930E-4SE Truck. Customer options may change this listing.

ENGINE

Komatsu SSDA18V170

No. of Cylinders	18
Operating Cycle	4-Stroke
Rated Brake Power	2 611 kW (3,500 HP) at 1900 RPM
Flywheel Power	2 558 kW (3,429 HP) at 1900 RPM
Weight (Wet)*	10 000 kg (22,266 lb)

* Weight does not include radiator, sub-frame or alternator.

AC ELECTRIC DRIVE SYSTEM

(AC/DC Current)

Alternator	General Electric GTA-39
Dual Impeller, In-Line Blower	453 m ³ / min (16,000 cfm)
Motorized Wheels	GDY106 AC Induction Traction Motors
Standard Gear Ratio*	32.62:1
Maximum Speed	64.5 kph (40 mph)

* Wheel motor application depends upon GVW, haul road grade and length, rolling resistance, and other parameters.
Komatsu and GE must analyze each job condition to ensure proper application.

DYNAMIC RETARDING

Electric Dynamic Retarding	Standard
Maximum Rating	4 026 kW (5,400 HP)
Continuous*	2 909 kW (3,900 HP)

* Continuously rated high-density blown grids with retard at engine idle and retard in reverse propulsion.

BATTERY ELECTRIC SYSTEM

Batteries	Four 8D, 12 volt wet batteries with disconnect switch
Cold Cranking Amps	1450 CCA
Alternator	24 Volt, 140 Amp Output
Lighting	24 Volts
Starters (2)	24 Volts

SERVICE CAPACITIES

Crankcase (including oil filters)	341 liters (90 gallons)
Cooling System	799 liters (211 gallons)
Fuel	5 300 liters (1400 gallons)
Hydraulic System	1 325 liters (350 gallons)
Wheel Motor Gear Box	95 liters (25 gallons) per wheel

WORKING NEAR BATTERIES

Battery Hazard Prevention

- Battery electrolyte contains sulfuric acid, which can quickly burn the skin and eat holes in clothing. If you spill acid on yourself, immediately flush the area with water.
- Battery acid can cause blindness if splashed into your eyes. If acid gets into your eyes, flush them immediately with large quantities of water and see a doctor at once.
- If you accidentally drink acid, drink a large quantity of water, milk, beaten eggs or vegetable oil. Call a doctor or poison prevention center immediately.
- Always wear safety glasses or goggles when working with batteries.
- Batteries generate hydrogen gas. Hydrogen gas is very explosive and can easily be ignited with a small spark or flame.
- Before working with batteries, stop the engine and turn the key switch to the OFF position.
- Avoid short-circuiting the battery terminals through accidental contact with metallic objects, such as tools, across the terminals.
- When removing or installing batteries, check which is the positive (+) terminal and the negative (-) terminal.
- Tighten the battery terminals securely. Loose terminals can generate sparks and lead to an explosion.
- Tighten battery caps securely.

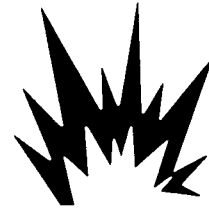
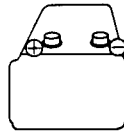
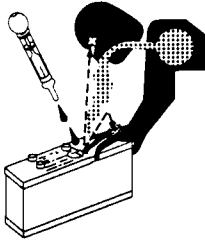

A030005

Manual DC Link Capacitor Discharge Procedure

Follow any and all local and site specific procedures and requirements for working on off-highway mining equipment.

1. Verify that the engine is off and the parking brake is on.
2. Verify that the generator field contactor (GF) switch (2, Figure 3-4) in the low voltage area of the control cabinet is in the CUTOFF position.
3. Move the control power switch (1) to the ON position for a minimum of 30 seconds. Then, turn the control power switch to the OFF position.

(With control power on, an RP contactor closes and discharges the DC link through the retarding grids in less than 10 seconds.)

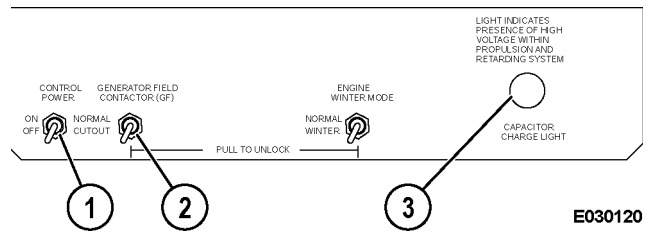

FIGURE 3-4. INFORMATION DISPLAY PANEL

- | | |
|-------------------------|---------------------------|
| 1. Control Power Switch | 3. Capacitor Charge Light |
| 2. GF Cutout Switch | |

In most control cabinets, RP2 is the normal discharge path. In groups containing an RP3 contactor, RP2 and RP3 are alternated as the normal discharge path. Refer to Figure 3-5.

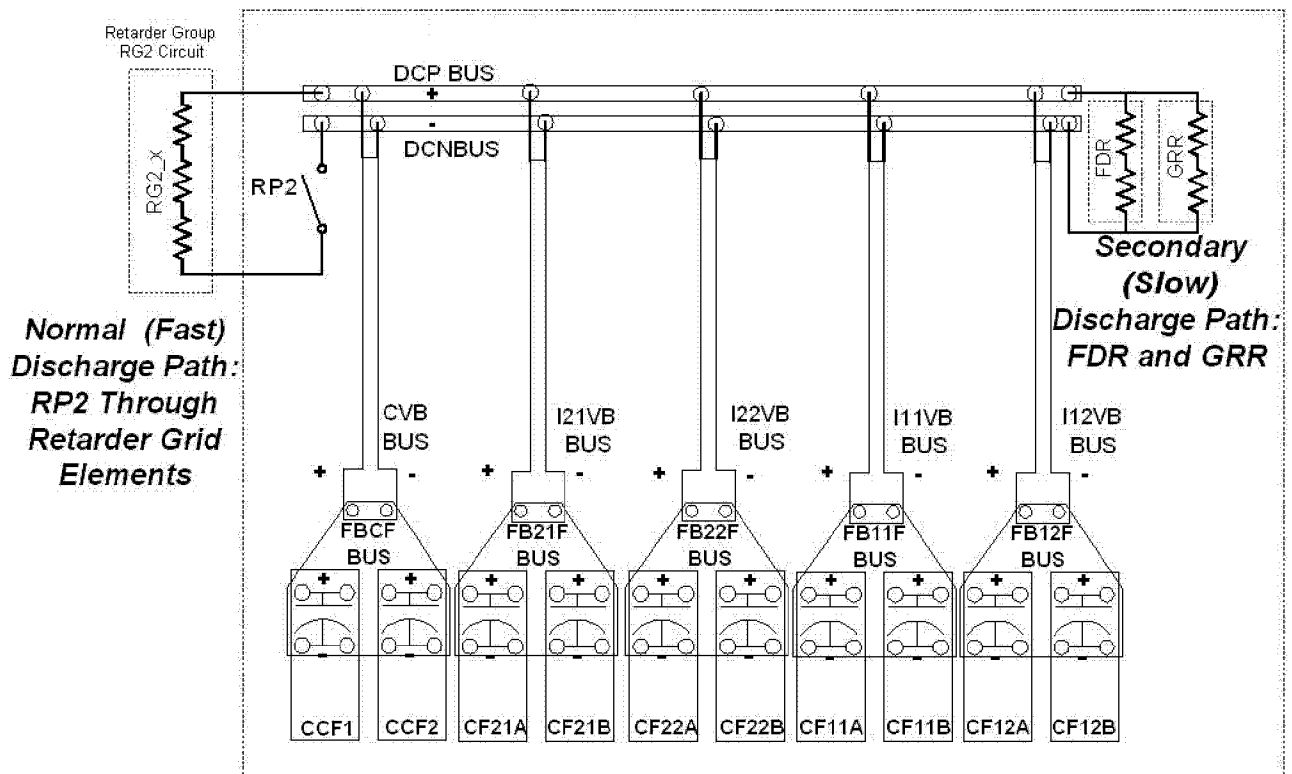

FIGURE 3-5. DISCHARGE PATHS

OPERATION

The static brake test utilizes a momentary switch and a check light located in the overhead display panel.

Brake Test Switch

The brake test switch is used to initiate a brake test. Press on the momentary switch to enter the brake test mode. If certain conditions are met, the operator can enter a brake test sequence.

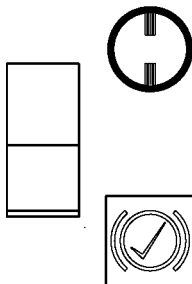

Brake Check Light

The amber light is used to indicate when the truck is in the brake test mode. When illuminated, a brake test is ready. When flashing, the brake test is at the validation point, or the retard system test is finished.



Description

The operator can choose which brake test to perform, and will set the truck controls based on the settings in Table 1. The drive system will detect the position of the directional control lever, and will prepare for the appropriate test. The operator will then press the brake test switch.

If the brake check light is illuminated solid after pressing the brake test switch, the system is in brake test mode and is ready for the chosen test to be initiated by the operator. After testing, the operator will then determine if the truck passed the brake tests, and if it is safe for operation.

If the brake check light does not illuminate immediately after pressing the brake test switch, there is most likely a problem with the setup. Refer to the setup conditions and take action to prepare the truck for a brake test.

If there is a problem with the truck setup, the DID panel will display the problem.

For example if the engine is off:

ERROR Entering Brake Test
Engine not running

If the Truck is loaded:

ERROR Entering Brake Test
Truck is NOT Empty

If all of the conditions are correct, except the brakes are not set correctly, an error message will be displayed. For example, if the service brake and parking brake are both applied together:

ERROR Entering Brake Test
Set Brakes for Test

Brake Test Exit Criteria

Numerous conditions can occur which may interrupt a brake test, including the following:

- Any of the setup conditions becoming false
- Drive system fault which restricts the LINK or Propel mode
- Truck Speed greater than 3.2 kph (2.0 mph)
- Drive system at torque level for more than 30 seconds
- Brake test requested, but not initiated by the operator within 60 seconds after pressing the brake test switch

Test Type	Wheel Brake Lock	Service Brake Pedal	Directional Control Lever
Service Brake	OFF	FULLY APPLIED	NEUTRAL
Parking Brake	OFF	RELEASED	PARK
Retard Test	OFF	RELEASED	PARK

SUDDEN LOSS OF ENGINE POWER

If the engine suddenly stops, there is enough hydraulic pressure stored in the brake and steering accumulators to allow the operation of the steering and brake functions. However, this oil supply is limited, so it is important to stop the truck as quickly and safely as possible after the loss of engine power.

If the brake supply pressure drops to a pre-determined level, the low brake oil pressure warning light will illuminate and sonalarm will sound. If the brake pressure continues to decrease, the auto-apply feature will activate and the service brakes will apply automatically to stop the truck.

1. Bring the truck to a safe stop as quickly as possible by using the foot pedal to apply the service brakes. If possible, safely steer the truck to the side of the road while braking.

WARNING

Dynamic retarding will not be available. Do not use the service brakes for continuous retarding purposes.

2. Move the directional control lever to PARK as soon as the truck has stopped moving.
3. Turn the key switch to the OFF position and notify maintenance personnel immediately.
4. If traffic is heavy near the disabled machine, mark the truck with warning flags during daylight hours or use flares at night. Adhere to local regulations.

FUEL DEPLETION

The high pressure injection (HPI) fuel system uses fuel to adjust fuel delivery timing by creating a hydraulic link between the upper plunger and the timing plunger. Metered fuel is also used for lubricating the injector plunger and barrel. The maximum demand for metered fuel is required during high speed / low load conditions.

CAUTION

Operating the truck to fuel depletion forces the injector train into a no-follow condition. No fuel flow between the plungers may cause damage to the injectors and the overhead due to adhesive wear, resulting in costly repairs and unnecessary downtime.

WARNING

Allowing the Komatsu truck to operate until fuel depletion can lead to unsafe operating conditions possibly resulting in an uncontrollable vehicle and/or personal injury.

TORQUE TABLES AND CONVERSION CHARTS

This manual provides dual dimensioning for many specifications. Metric units are specified first, with U.S. standard units in parentheses. When torque values are not specified in the assembly instructions contained in this manual, use the standard torque value for the hardware being used. Standard value torque tables are contained in this chapter for metric and SAE hardware.

NOTE: This truck is assembled with both metric and SAE (U.S.) hardware. Reference the correct table when determining the proper torque value.



References throughout the manual to standard torques or other standard values will be to one of the following tables. Do not use standard values to replace specific torque values in assembly instructions.

For values not shown in any of the charts or tables, standard conversion factors for most commonly used measurements are provided in the following tables.

INDEX OF TABLES

TABLE	Page
TABLE 1 Standard Tightening Torque For Metric Cap screws and Nuts	12-2
TABLE 2 Standard Tightening Torque For SAE Grade 5 & 8 Cap Screws and Nuts	12-3
TABLE 3 Standard Tightening Torque 12-Pt, Grade 9, Cap Screws (SAE)	12-4
TABLE 4 Tightening Torque for T-Bolt Type Hose Clamps.	12-5
TABLE 5 Standard Tightening Torque For Split Flange Clamp Bolts	12-5
TABLE 6 Tightening Torque For Flared Tube And Hose Fittings	12-5
TABLE 7 JIC 37° Swivel Nuts Torque Chart (SAE)	12-6
TABLE 8 Pipe Thread Torque Chart (SAE)	12-6
TABLE 9 O-Ring Boss Torque Chart (SAE)	12-7
TABLE 10 O-Ring Face Seal Torque Chart (SAE)	12-7
TABLE 11 Common Conversions Multipliers - Metric -to- English	12-8
TABLE 12 Common Conversions Multipliers - English -to- Metric	12-9
TABLE 13 Temperature Conversions.	12-10

11. All lubrication points (grease fittings) should be serviced with the recommended lubricants.
12. Relieve the tension from all drive belts. The engine manufacturer recommends insertion of heavy kraft paper between the belts and pulleys to prevent sticking.
13. All vandalism covers and locks should be in place and secured.
14. All cab windows should be closed, locked and sealed, and the cab door should be locked to prevent vandalism and weather effects.
15. The fuel tank should be completely drained of fuel, fogged with preservative lubricant (NOX-RUST MOTOR STOR., SAE10), and closed tightly. All fuel filters should be replaced.
16. If possible, all available service publications (vehicle and engine) and a current parts catalog should be packaged in a moisture proof package and placed in the cab to aid whomever will eventually place the unit back in operation.
17. Ensure that the water drain holes in the truck body are open.

REMOVAL FROM STORAGE

If the storage preparations were followed when placing the vehicle into storage, getting it back to operational status is a matter of reversing those steps.

NOTE: Before starting the job of restoring a vehicle to operation, obtain copies of the Operation and Maintenance Manual, Service Manual, Engine Manuals and Parts Book, if possible, and follow all special instructions regarding servicing the vehicle and its components.

In addition to removing the storage materials, the following actions should be taken:

1. Inspect the entire vehicle carefully for rust and corrosion. Correct as necessary.
2. Service the engine according to the engine manufacturer's Operation and Maintenance Manual.
3. Clean the radiator. Refer to Section C, Cooling System, for cleaning instructions.
4. The cooling system should be completely drained, chemically flushed, and refilled with a conditioned water/antifreeze solution suitable for the lowest temperature anticipated. Refer to Fluid Specifications in Section P, Lubrication and Service, for the proper anti-freeze and conditioner concentrations. After refilling the system, always operate the engine until the thermostats open to circulate the solution through the cooling system.
5. Thoroughly inspect all drive belts and hydraulic oil lines for damage, wear or deterioration. Replace any suspected lines. Do not take chances on possible ruptures or blow-outs.
6. New hydraulic filters should be installed and the hydraulic tank checked and serviced with Type C-4 oil as specified in Section P, Lubrication and Service.

7. Perform a megohmmeter test. Refer to the truck's Vehicle Test Instructions for the correct procedure. If Megger readings are less than 2.0 megohms, the problem could be an accumulation of moisture in the motor or alternator. If this is the case, the faulty component will have to be isolated and dried out using procedures outlined in the G.E. Service Manual.
8. Perform a thorough inspection of the motorized wheels, alternator, blowers and control compartments. Look for:
 - Rust or dirt accumulation on machine surfaces
 - Damaged insulation
 - Any accumulation of moisture or debris, especially in the ductwork
 - Loose wiring and cables
 - Any rust on electrical connectors in the control compartment
 - Any loose cards in the card panels
9. Clean and make repairs as necessary.
10. Check the retarding grids and insulators for loose connections and dirt accumulation. Clean and tighten connections as necessary.
11. Where applicable, check exciter drive belts for cracks and deterioration. If acceptable, set the belt tension to specification.
12. Before starting the engine, turn on the control power. Check that the contactors and relays pick up and drop out normally.
13. Perform a startup procedure on the complete system to ensure maximum performance during service. Refer to the truck's Vehicle Test Instructions for the complete test procedure.

After all storage protection has been removed, the truck has been cleaned and inspected, all repairs have been made, the motorized wheel gearcase has been filled with new oil, the dirt seals have been completely purged with new grease, and the system has been completely checked, the truck can be placed into service. However, it is recommended that the truck be driven unloaded at a low speed of no more than 16 km/h (10 mph) for the first hour of operation.

**SECTION B3
DUMP BODY
INDEX**

DUMP BODY B3-3
 Removal B3-3
 Installation B3-4
BODY PADS B3-6
 Body Pad Shimming Procedure B3-7
BODY GUIDE B3-8
HOIST LIMIT SWITCH B3-8
BODY-UP SWITCH B3-8
BODY RETENTION SLING B3-8
ROCK EJECTORS B3-9
 Inspection B3-9

FUEL TANK

FUEL TANK

Removal

1. Raise the truck body and install the body retention sling.
2. Loosen filler cap (5, Figure 4-1) and open the drain cock on the bottom of fuel tank (1) to drain the fuel from the tank into clean containers. Tighten the filler cap when the fuel is completely drained.
3. Disconnect the wire harness from hoist circuit filter assemblies (11) and steering circuit filter assembly (12). Remove ground wire (13).
4. If equipped, close the inline shutoff valves. Remove fuel return hose (6), fuel supply hose (7) and quick fill hose (10). Cap the hoses and tank fittings to prevent contamination.
5. Remove hoist circuit filter assemblies (11) and steering circuit filter assembly (12) from the fuel tank. Support the filter assemblies by placing a chain over the frame rail. It is not necessary to remove the hydraulic hoses.



The weight of the empty fuel tank is approximately 2 045 kg (4,510 lb). Use lifting devices with adequate capacity to remove the fuel tank.

6. Attach a lifting device to the lifting eyes on each side of the tank.
7. Remove capscrews (14), lockwashers (15), flat washers (16), large washers (17) and rubber mounts (16). Remove capscrews (2), lockwashers (3) and mounting caps (4).
8. Lift the fuel tank from the brackets and move it to a work area.

Repair

If a tank has been damaged and requires structural repair, perform such repairs before final cleaning.



If a tank is to be weld repaired, special precautions are necessary to prevent fire or explosion. Consult local authorities for safety regulations before proceeding.

Cleaning

The fuel tank has a drain cock and a cleaning port in the side that allow steam or solvent to be used for cleaning tanks that have accumulated foreign material.

It is not necessary to remove the tank from the truck for cleaning of sediment. However, rust and scale on the walls and baffles may require complete tank removal. This allows cleaning solutions to be in contact with all interior surfaces by rotating the tank in various positions.

Before a cleaning procedure of this type, the fuel gauge sender, vent assembly (8, Figure 4-1) and all hose connections must be removed and temporarily sealed. After cleaning is complete, the temporary plugs can be removed.

If the tank is to remain out of service, a small amount of light oil should be sprayed into the tank to prevent rust. Seal all openings for rust prevention.

Installation

1. Thoroughly clean the frame mounting brackets and the mounting hardware holes. Re-tap the threads if damaged.



The weight of the empty fuel tank is approximately 2 045 kg (4,510 lb). Use lifting devices with adequate capacity to install the fuel tank.

2. Attach a lifting device to the lifting eyes on each side of the tank. Lift the fuel tank into position over the frame trunnion mounts and lower it into position.
3. Install mounting caps (4, Figure 4-1), lockwashers (3) and capscrews (2). Do not tighten the capscrews at this time.
4. Install rubber mounts (18), large washers (17), flat washers (16), lockwashers (15) and capscrews (14). Tighten the lower mounting capscrews to **800 ± 80 N·m (590 ± 59 ft lb)**.
5. Tighten the upper mounting capscrews to **712 ± 72 N·m (525 ± 53 ft lb)**.
6. Install hoist circuit filter assemblies (11) and steering circuit filter assembly (12) on the tank.

19. Remove radiator upper support rod (1, Figure 2-7) at each side of radiator.
20. Remove the diagonal ladder from truck. Refer to Section B2, Structural Components, for the removal procedure.
21. Refer to Section N4, Heater/Air Conditioner, for the procedures required to properly remove the refrigerant.

NOTE: The system contains HFC-134A refrigerant.



Federal regulations prohibit venting air conditioning system refrigerants into the atmosphere. An approved recovery/recycle station must be used to remove the refrigerant from the air conditioning system.

22. After the air conditioning system has been discharged, disconnect the refrigerant hoses that are routed to the cab at the compressor and the receiver/drier.

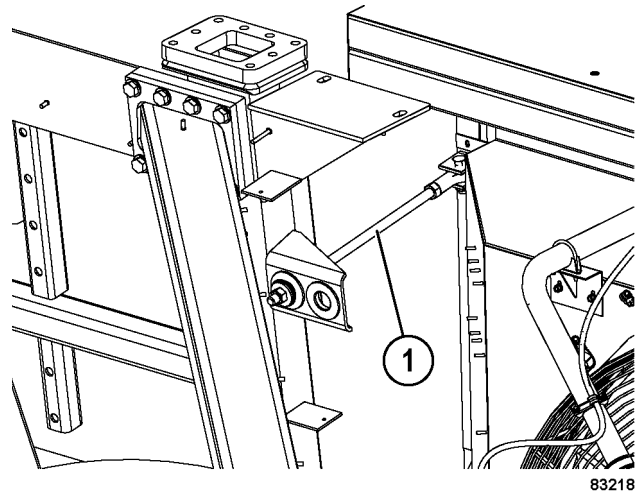

FIGURE 2-7. RADIATOR UPPER SUPPORT ROD

1. Radiator Upper Support Rod

Disassembly

⚠ IMPORTANT ⚠

To aid in removal of the tubes, clean the radiator prior to disassembly. Heating the seals with hot water helps to loosen the grip on the tubes. Cleaning the radiator prior to disassembly also reduces the risk of internal contamination. After cleaning, spray lubricating oil at the top end of the tubes.

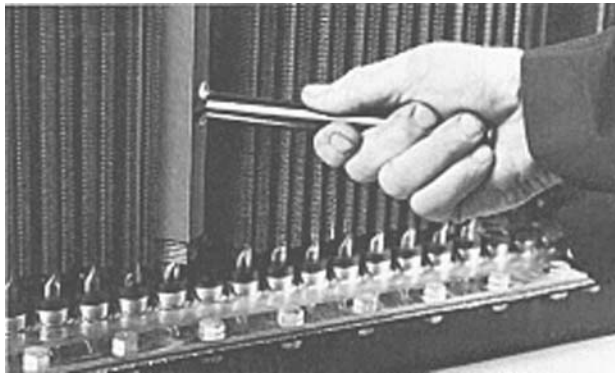

FIGURE 3-6. BREAKER TOOL (XA2307)

1. Start at the top row of tubes. Use the breaker tool (XA2307) to loosen the tube to be removed. When using the breaker tool, position it at the top or bottom of the tube. Never position it in the middle of the tube or damage may result. Use the breaker tool to lightly twist the tube back and forth within the seals to loosen the grip. Refer to Figure 3-6.

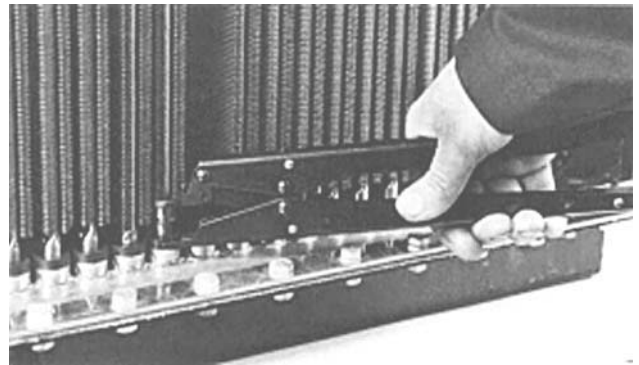

FIGURE 3-7. INSTALLATION TOOL (VJ6567)

2. After the tube is loose, position the installation tool (VJ6567) at the bottom of the tube to be removed. Refer to Figure 3-7. The upper jaw of the installation tool should be positioned just below the rectangular section of the tube. The bottom jaw should rest on the seal. Squeeze the installation tool just enough to allow the bottom of the tube to be removed from the bottom seal.

NOTE: To ease in the removal of tubes, use the breaker tool and installation tool simultaneously.

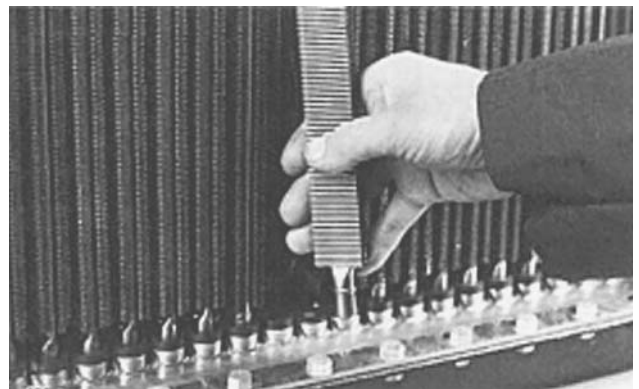
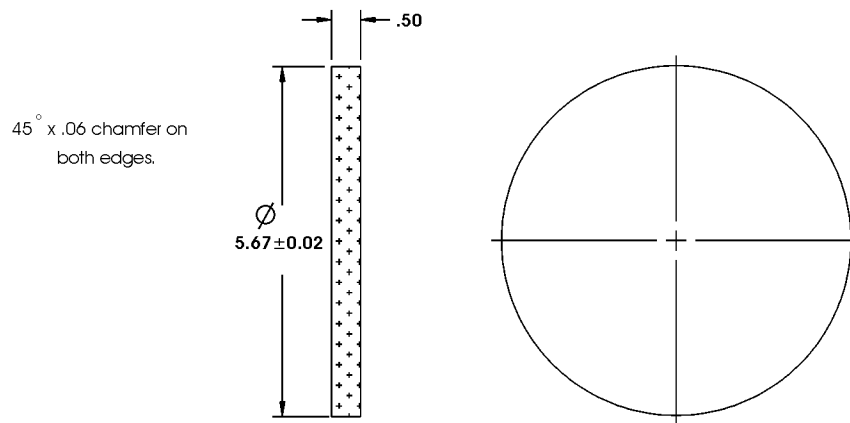

FIGURE 3-8. ANGLING TUBE DURING REMOVAL

3. Pull the tube from the top seal while simultaneously twisting the tube. Angle the tube only far enough to clear the radiator. Refer to Figure 3-8. Removing the tube at an excessive angle may cause damage to the tube.
4. Remove all the top tubes before removing the bottom tubes. After all of the tubes are removed, use pliers to remove the seals from the tanks. Discard all seals. New seals must be used for assembly.

**SECTION C5
AIR CLEANERS
INDEX**

OPERATION	C5-3
SERVICING THE AIR CLEANERS	C5-3
Replacing The Filter Elements	C5-3
Cleaning The Main Filter Element	C5-5
Servicing The Precleaner Section	C5-6
EVACUATOR VALVES (if equipped)	C5-7
AIR INTAKE TROUBLESHOOTING	C5-7



Dimensions in inches unless otherwise specified.

M060072

TOOL E - BEARING INSTALLER

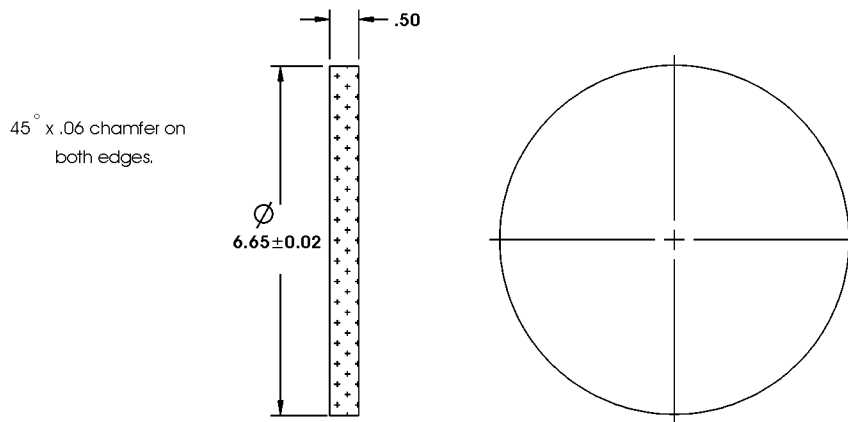

M060073

TOOL F - BEARING INSTALLER

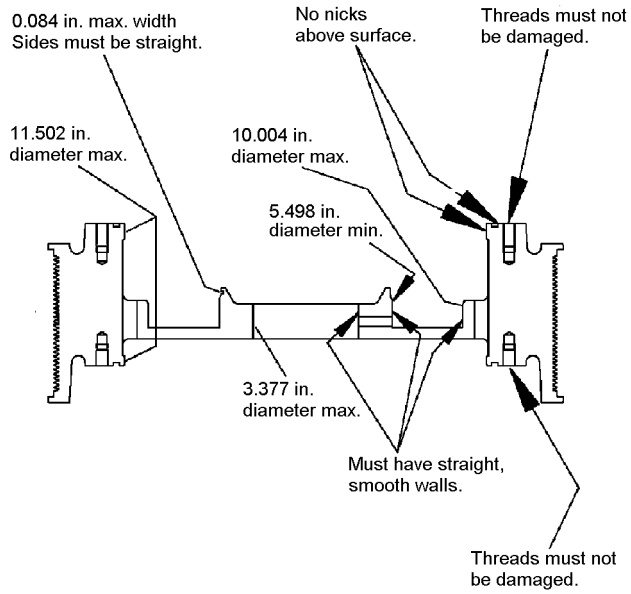

FIGURE 7-32.

M060092

3. Check pulley and adapter dimensions.

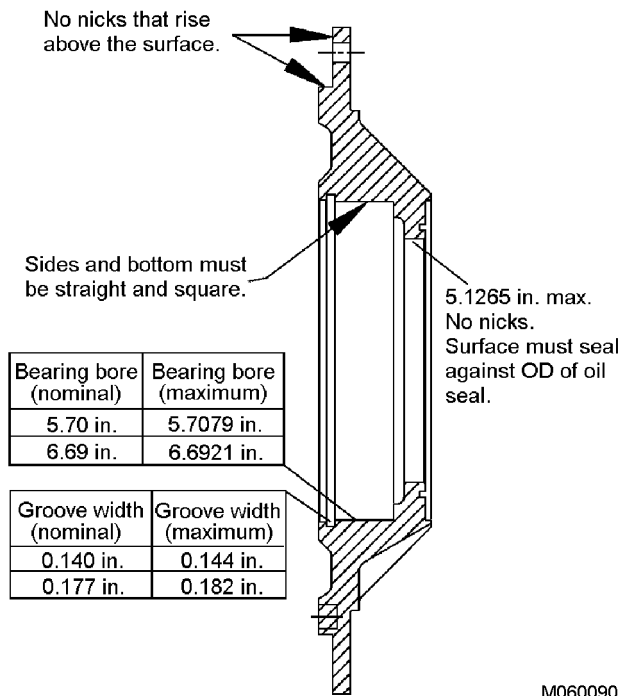

FIGURE 7-33.

M060090

4. Check rear bearing retainer (11) dimensions.

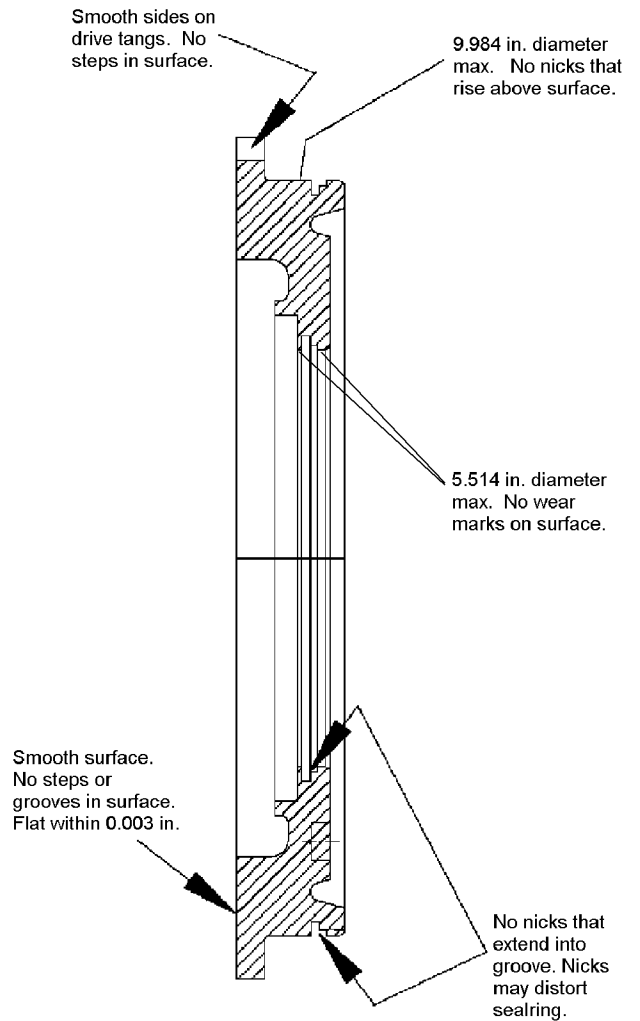

FIGURE 7-34.

M060091

5. Check piston (23) dimensions.

Push the pitot tubes to the bottom of the hole. The outer end of the tube should be located well within the pulley-locating shoulder of the bearing retainer. Rotate the tube so the open, bent end faces in a counterclockwise direction and is *exactly* parallel to the surface of the bearing retainer. (A large phillips-head screwdriver inserted in the end of the tube can be used as an alignment gage).

Install the second pitot tube in the same manner as the first. Stake each pitot tube in three places (at the 9, 12, and 3 o'clock positions) to prevent the tubes from rotating in operation.

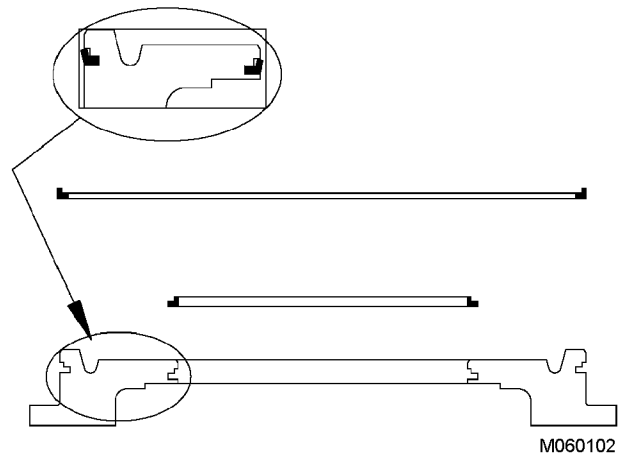

FIGURE 7-66.

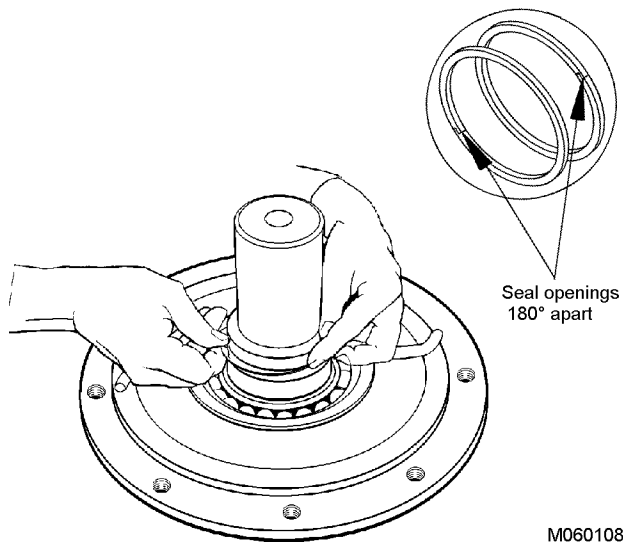

FIGURE 7-65.

25. Install both hook-type seal rings (17) in the grooves in the shaft. Rotate the rings so the slits in the rings are 180 degrees apart from one another.

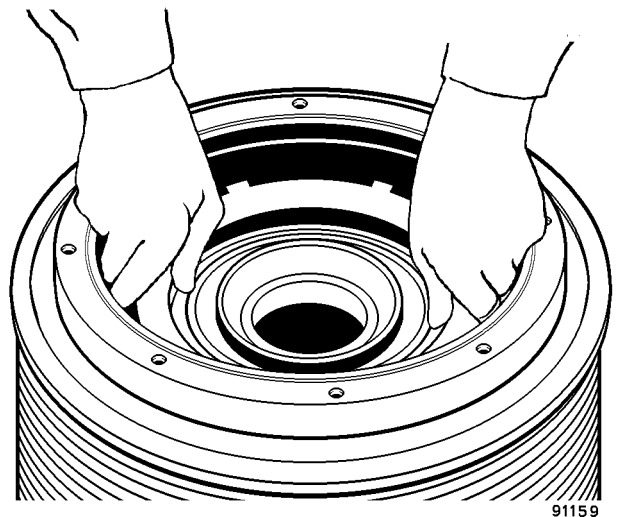

FIGURE 7-67.

26. Lubricate the seal ring grooves of piston (23) with an oil-soluble lubricant such as engine assembly grease. Install small seal ring (24) in the inside groove and large seal ring (22) in the outside groove. Refer to Figure 7-66 for proper orientation.

27. Lubricate the external surfaces of seal rings (22) and (24) with an oil-soluble lubricant such as engine assembly grease. Also lubricate the seal mating surfaces in the pulley adapter.

BATTERY SUPPLY SYSTEM

24VDC Battery Charging Alternator

The battery charging alternator is a 24-Volt (140 Amp) alternator. Refer to the engine manufacturer's service manual for more information.

Batteries

Four type 8D batteries (3, Figure 2-1) for the 24VDC engine start circuit are located in the battery box in the center of the front platform.

For access to the batteries, open the hinged cover by turning cover latches (1) counterclockwise until released. Lifting eyes are attached to each end of the battery box so that the entire battery box assembly can be removed, if necessary.

24VDC Auxiliary Battery Receptacles

Two receptacles (2) are provided to attach battery charger leads for charging the batteries. These receptacles can also be used for connecting external batteries to aid engine starting during cold weather.

When external batteries are used, they should be of the same type (8D) as the batteries installed on the truck. Two pairs of batteries should be used. Each pair should be connected in series to provide 24VDC, with one pair connected to each receptacle.

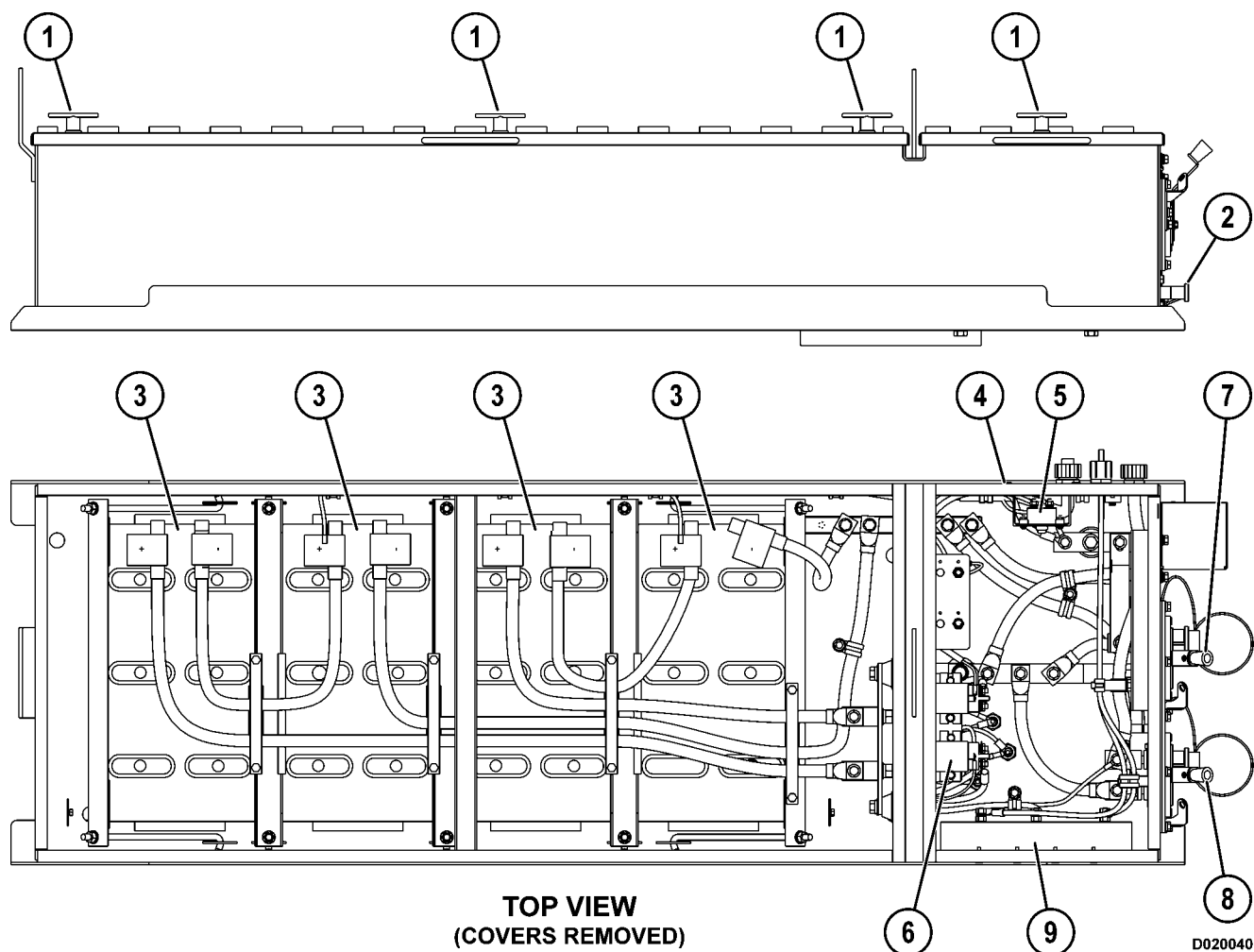
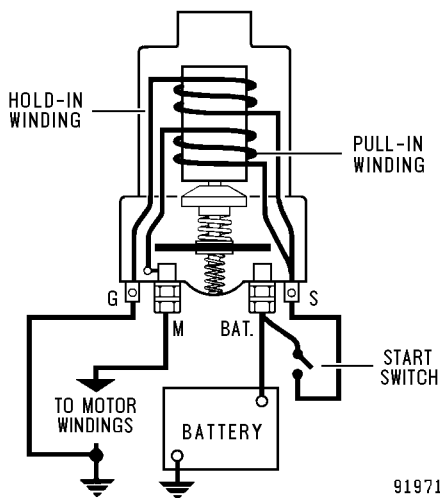

FIGURE 2-1. BATTERY BOX COMPONENTS

- | | | |
|----------------------------------|-----------------------------|------------------------------|
| 1. Battery Box Cover Latch | 4. Battery Control Box | 7. Starter Disconnect Switch |
| 2. Auxiliary Battery Receptacles | 5. Circuit Breaker (50 amp) | 8. Master Disconnect Switch |
| 3. Batteries | 6. Engine Start Relay | 9. Isolation Diode |



91971

FIGURE 2-7. SIMPLIFIED SOLENOID CIRCUIT

SOLENOID CHECKS

A basic solenoid circuit is shown in Figure 2-7. Solenoids can be checked electrically using the following procedure.

Test

1. With all leads disconnected from the solenoid, make test connections as shown to the solenoid, switch terminal and to the second switch terminal "G", to check the hold-in winding (Figure 2-8).
2. Use the carbon pile to decrease the battery voltage to 20 volts. Close the switch and read current.
 - ❑ The ammeter must read 6.8 amps maximum.
3. To check the pull-in winding, connect from the solenoid switch terminal "S" to the solenoid motor "M" or "MTR" terminal (Figure 2-9).



To prevent overheating, DO NOT leave the pull-in winding energized more than 15 seconds. The current draw will decrease as the winding temperature increases.

4. Use the carbon pile to decrease the battery voltage to 5 volts. Close the switch and read current.
 - ❑ The ammeter must read 9.0 to 11.5 amps.

NOTE: High readings indicate a shorted winding. Low readings indicate excessive resistance.

5. To check for grounds, move battery lead from "G" (Figure 2-8) and from "MTR" (Figure 2-9) to the solenoid case. Ammeter must read zero. If not, the winding is grounded.

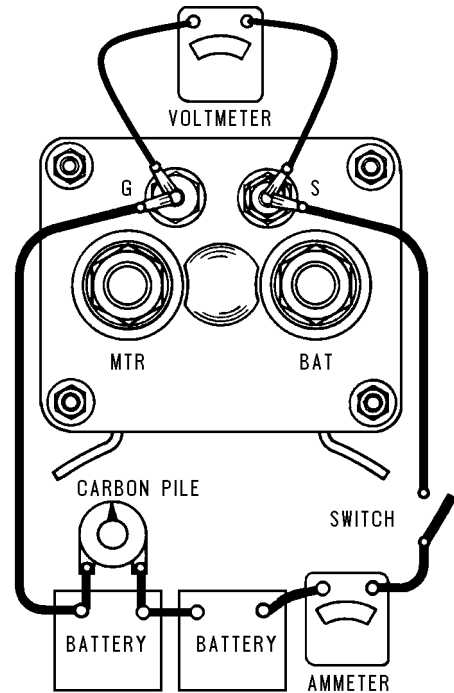

91972

FIGURE 2-8. SOLENOID HOLD-IN WINDING TEST

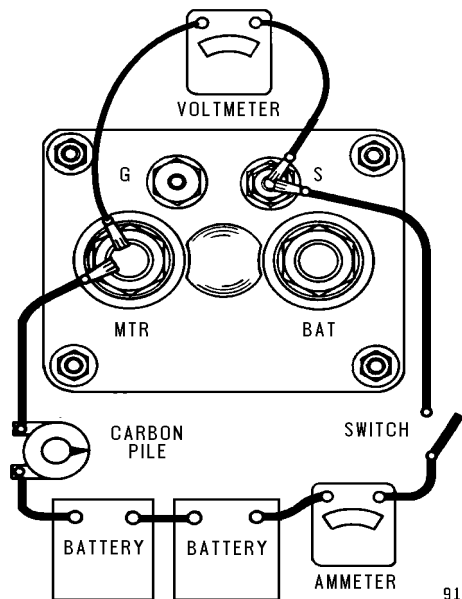

91973

FIGURE 2-9. SOLENOID PULL-IN WINDING TEST

RELAY BOARDS

The auxiliary control cabinet contains eight relay boards to provide control for many of the 24VDC circuits. Two types of boards are used. One type of board contains circuit breakers in addition to 24VDC relays and a PC board for special functions. The second type of board contains relays only.

All relays are interchangeable. The circuit breakers are also interchangeable as long as the circuit breaker capacity is the same.



Do not interchange or replace any circuit breaker with one of a different capacity than specified for the circuit. Serious damage or a fire may result if the wrong capacity breaker is used.

The relay boards are identified as follows:

Relay Board	Functions
RB1	Clearance/Turn Signal Lights
RB3	Stop, Retard, Backup Lights
RB4	Parking Brake, Horn, Body-Up, Engine Cranking
RB5	Headlights (standard)
RB6	Headlights (HID), Backup Horn, Auto Lube Solenoid & Timer, Ether Start, Engine Interlock, Bleeddown Power
RB7	Brake Lock, IM Warning, Timed Engine Shutdown
RB8	PLMIII Lights, Shutter Control, TCI
RB9	Start Circuit, Brake Auto Apply, Low Steering Pressure, Parking Brake OFF, Key Switch START

Refer to Figure 3-1 for the location of each relay board. Refer to the Circuit Breakers chart at the end of this section for electrical circuit identification numbers.

Relay Boards RB1, RB3, RB4, RB5

Each relay board of this type is equipped with four green lights (9, Figure 3-6) and one red “breaker open” light (7). Each relay board has a fifth green (8) light that has a different function on each board.

Four green lights (9) are labeled K1, K2, K3, or K4. These lights will be on only when that particular control circuit has been switched ON and the relay coil is being energized. The light will not turn on if the relay board does not receive the 24 volt signal to turn on a component.

If illuminated, red “breaker open” light (7) indicates that a circuit breaker on that relay board is in the OFF position. A light on the overhead display panel will also illuminate, informing the operator that a circuit breaker is in the OFF position. The red “breaker open” light will turn ON whenever there is a voltage difference across the two terminals of a circuit breaker.

If a control switch has been turned ON and a green (K) light is on, but that component is not operating, check the following on the relay board for that circuit:

- If a circuit breaker light is on, press all the circuit breakers to make sure that they are all on. There is no visual indication as to which circuit breaker has been tripped. Check the operation of the component. If it trips again, check the wiring or component for the cause of the overload.
- The contacts inside the relay may not be closing, or the contacts may be open, preventing an electrical connection. Swap relays and check again. Replace defective relays. Relays may take one minute to trip and 30 seconds before they can be reset.
- Check the wiring and all of the connections between the relay board and the component for an open circuit.
- The component may be defective. Replace the component.
- There is a poor ground at the component. Repair the ground connection.

KOMTRAX PLUS

KOMTRAX PLUS BASIC FEATURES

The center of KOMTRAX Plus is the KOMTRAX Plus controller, which gathers data about the operation of the truck from sensors and other controllers installed on the truck. Refer to Figure 11-1 for an overview of the KOMTRAX Plus components.

For instructions on how to use KOMTRAX Plus software programs, refer to KOMTRAX Plus Software elsewhere in this section. For error codes, checkout and troubleshooting procedures, refer to KOMTRAX Plus Troubleshooting and Checkout Procedures elsewhere in this section.

Gather Data

The KOMTRAX Plus controller gathers data from three sources. Real-time and alarm data from each controller is gathered continually. In addition, haul cycle summary data from the PLM III is requested by the controller one time per day.

The system performs three primary functions:

1. Gathers data from on-board sources:
 - PLM III controller
 - Interface Module (IM)
 - Engine controllers
2. Converts data into usable formats and records it into permanent memory.
3. Communicates data to off-board systems:
 - Satellite (Orbcomm)
 - PC download

NOTE: The electric drive system does provide a limited number of faults to the interface module. Refer to KOMTRAX Plus Troubleshooting later in this section for a complete listing of fault codes that are generated by the drive system.

Convert and Record Data

KOMTRAX Plus controller (2, Figure 11-1) processes data received from external controllers and stores the following data in internal memory:

- Fault codes from the engine, Interface Module, and PLM III
- Snapshots of data when specific fault codes occur
- Trends of specific engine and chassis parameters
- Load map and other measures of engine and chassis usage
- Haul cycle summary information, including payload, distance traveled, and travel times

In addition to data gathered from external controllers, KOMTRAX Plus records information about the vehicle and KOMTRAX Plus usage, including:

- Key ON and engine ON record
- KOMTRAX Plus configuration changes.

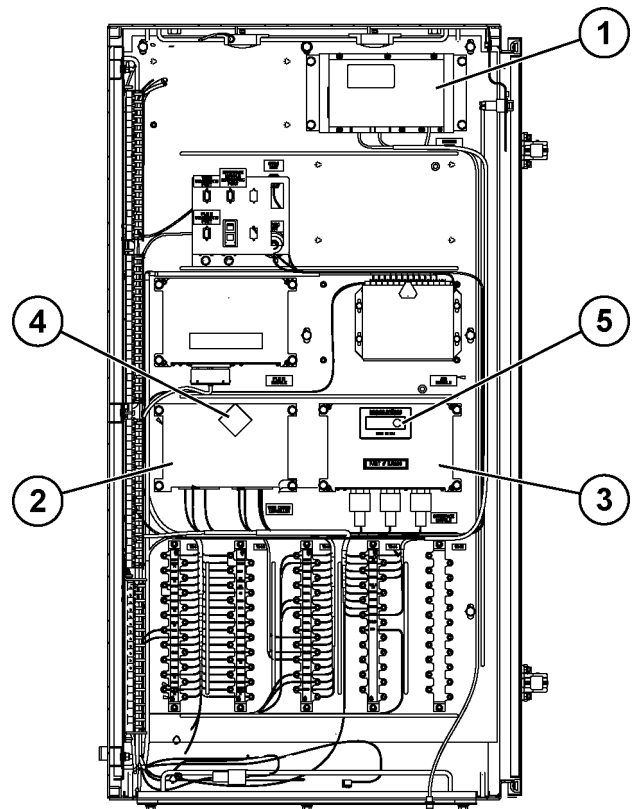

FIGURE 11-1. KOMTRAX PLUS COMPONENTS

- | | |
|----------------------------|---------------------|
| 1. Orbcomm Controller | 3. Interface Module |
| 2. KOMTRAX Plus Controller | 4. Red LED Digits |
| | 5. Green LED Light |

Removal

If the KOMTRAX Plus controller has to be replaced, the following steps must be performed in order to maintain accurate information after the controller has been replaced. If the new controller is not set up correctly (like the one being removed), the data in the controller and at WebCARE may not be usable.

Some steps will require using a laptop PC and the *VHMS Setting Tool* software or the *VHMS Technical Analysis Tool Box* software. For more detailed instructions on performing these steps with a laptop PC and software, refer to "KOMTRAX Plus Software" later in this section.

During the controller replacement process, two data downloads will have to be taken (one before, one after) and sent to WebCARE. Also, a KOMTRAX Plus initialization form will have to be filled out and sent to Komatsu North America as shown on the form.

1. With the key switch OFF, connect a laptop PC to the controller using the serial cable.
2. Using a laptop PC and the *VHMS Technical Analysis Tool Box* software, perform a complete data download from the controller. Refer to "When Replacing a KOMTRAX Plus Controller" later in this section.
3. Save this data so it can be sent to WebCARE at a later time when a connection to the internet is available.
4. Using the *VHMS Setting Tool* software, enter the Service ID and choose the "Save/Load" function.
5. From the File menu, select "Save".
6. Capture a screen shot ("Alt" and "Print Screen" keys at the same time) of the Save Confirmation window, paste it into a Microsoft Word document and save it.
7. Click the "OK" button to save the settings.
8. Exit the *VHMS Setting Tool* program.
9. Turn the key switch OFF.
10. Wait three minutes, then disconnect battery power.
11. After the two LED lights are off, disconnect the wiring harnesses and remove the controller.

Installation

1. Install the new controller and connect the wiring harnesses to it. Connect the laptop PC to the controller with the serial cable.
2. Connect battery power. Turn the key switch ON, but do not start the engine.
3. With the *VHMS Setting Tool* software, enter the Service ID and choose the "Save/Load" function.
4. From the file menu, select "Load".
5. Capture a screen shot ("Alt" and "Print Screen" keys at the same time) of the Save Confirmation window, paste it into a Microsoft Word document and save it.
6. Click the [OK] button to load the settings.
7. Click the [Apply] button to reset the controller, then click the [OK] and [Yes] buttons to confirm. Then select the [Close] button.
8. Fill out a KOMTRAX Plus initialization form and send it to Komatsu as instructed on the form.
9. Exit the *VHMS Setting Tool* program.
10. Turn the key switch OFF and wait three minutes.
11. Turn the key switch ON. Wait three minutes and watch for any error messages on the controller LED lights that might indicate a problem in the system.
12. If there are no error messages, continue to Step 13. If there are error messages, refer to the KOMTRAX Plus Troubleshooting and Checkout procedures elsewhere in this section.
13. Using a laptop PC and the *VHMS Technical Analysis Tool Box* software, perform a complete data download from the controller.
14. Confirm the download data is good by using the *VHMS Technical Analysis Tool Box* software. Make sure the settings are correctly applied by looking at the date, time, SMR, etc.
15. Turn the key switch OFF. Disconnect the laptop PC from the controller.
16. Use internet access available to the laptop PC to send the download data set that was taken before the controller was removed from the truck to WebCARE. Use the FTP feature built into the *VHMS Technical Analysis Tool Box* program to send the files.
17. Use the FTP program to send the download data set that was taken after the new controller was installed to WebCARE.

3. After selecting one of the following choices, click the [Next] button.

- Date & Time
- Satellite
- Payload Meter

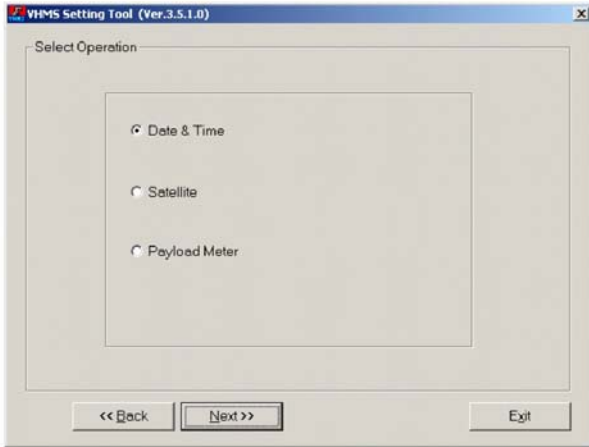

D120036

a. Date & Time: Should be set to current date and time. If not correct, set the correct Time Zone, Date and Time to current time zone, date and time. Select [DST Summer Time] if it applies. Click the [Apply] button.

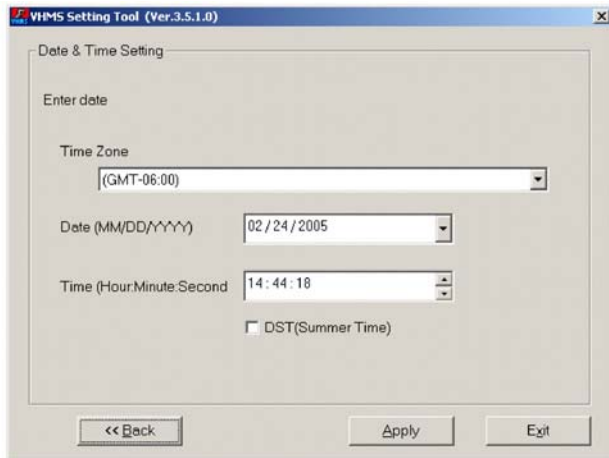

D120037

b. Satellite: Select the correct country location from the drop-down menu, then click the [Apply] button to change the setting.

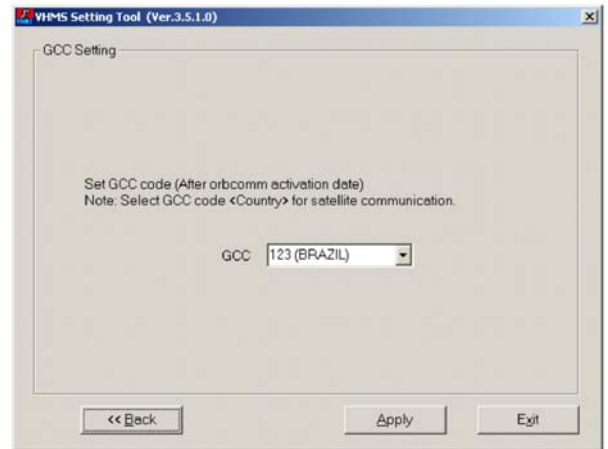

D120035

c. Payload Meter: Set Start Time to "0", and Interval to 1. Then click the [Apply] button to save the setting.

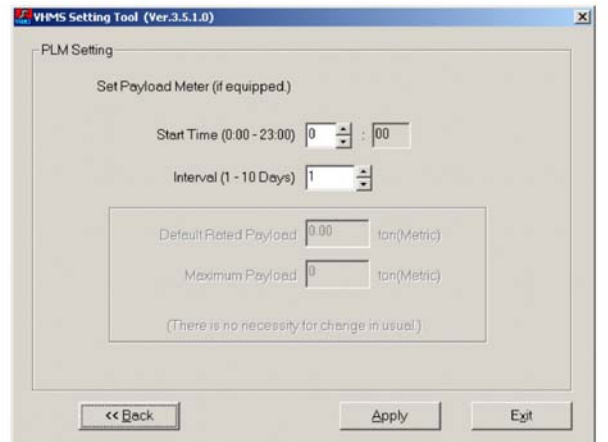

D120062

INTERFACE MODULE CHECKOUT

▲ IMPORTANT ▲

If a new truck with KOMTRAX Plus is being assembled, or a new KOMTRAX Plus system has just been installed, refer to the KOMTRAX Plus System for instructions regarding the initialization procedure. The initialization procedure and form must be completed before the truck can be put into service.

Necessary Equipment

- System schematic
- Laptop PC
- *Interface Module Real Time Data Monitor* software
- Serial cable (RS232)
- Jumper wire 77 mm (3 in.) or longer
- Volt Meter
- 300 to 332 ohm resistor
- 3/8 in. nut driver

NOTE: The interface module must already have the application code installed.

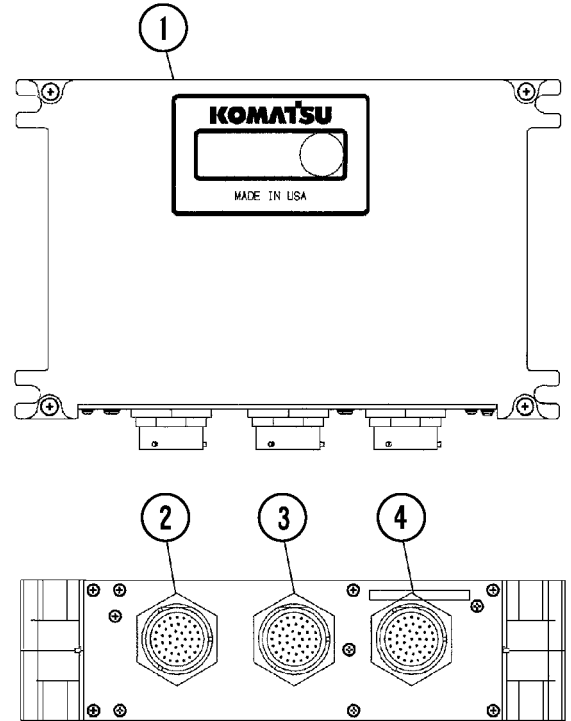

D110014

FIGURE 12-4. INTERFACE MODULE

- | | |
|---------------------|------------------|
| 1. Interface Module | 3. Connector IM2 |
| 2. Connector IM1 | 4. Connector IM3 |

KOMTRAX Plus LED Display Fault Codes

The KOMTRAX Plus controller also indicates some faults on the two red LED digits on the top of the controller. Fault codes are flashed as a two part sequence, as shown in the table below.

When no communication errors are occurring, the KOMTRAX Plus controller LED digits count from 00 - 99 continuously at a rate of ten numbers per second.

Table 2: KOMTRAX Plus LED Display Error Codes		
Fault Code	Fault Condition	LED Display
M101	Truck Frame Number Changed	Alternates 'n1' and '01'
M801	Can-net System (J1939)	Alternates 'n8' and '01'
M804	Can-net System (RPC)	Alternates 'n8' and '04'
M806	IM Stopped Real Time Data	Alternates 'n8' and '06'
M807	Too Much Payload Data For Requested Period	Alternates 'n8' and '07'
M808	PLMIII Stopped Real Time Data	Alternates 'n8' and '08'
M809	Can-net System (QUANTUM)	Alternates 'n8' and '09'
M80A	Can-net System (CENSE)	Alternates 'n8' and '0A'
M901	Source Voltage Error	Alternates 'n9' and '01'
M902	24V Source System Error	Alternates 'n9' and '02'
M903	12V Source System Error	Alternates 'n9' and '03'
M904	5V Source System Error	Alternates 'n9' and '04'
M905	Abnormality in VBAT Voltage (VBAT <10V)	Alternates 'n9' and '05'
M990	Ethernet Power Short	Alternates 'n9' and '90'
MC10	MEMORY CLEAR: Failure History	Alternates 'nc' and '10'
MC31	MEMORY CLEAR: (Load Map)	Alternates 'nc' and '31'
MC40	MEMORY CLEAR: (Trend Analysis)	Alternates 'nc' and '40'
MC60	MEMORY CLEAR: (Snap Shot)	Alternates 'nc' and '60'
MC91	MEMORY CLEAR: (Maintenance History)	Alternates 'nc' and '90'
ME01	Change Service Meter	Alternates 'ne' and '01'
ME02	Change Calendar	Alternates 'ne' and '02'
ME03	Orbcomm Settings	Alternates 'ne' and '03'
ME04	Other Settings	Alternates 'ne' and '04'
ME05	MEMORY CLEAR: All	Alternates 'ne' and '05'
ME06	Initialized	Alternates 'ne' and '06'
MF11	KOMTRAX Plus Connector Mismatch	Alternates 'nf' and '11'
MFA0	Manual Trigger	Alternates 'nf' and 'A0'

Flashing Error Code N4-23 (PLM III Communications Fault)

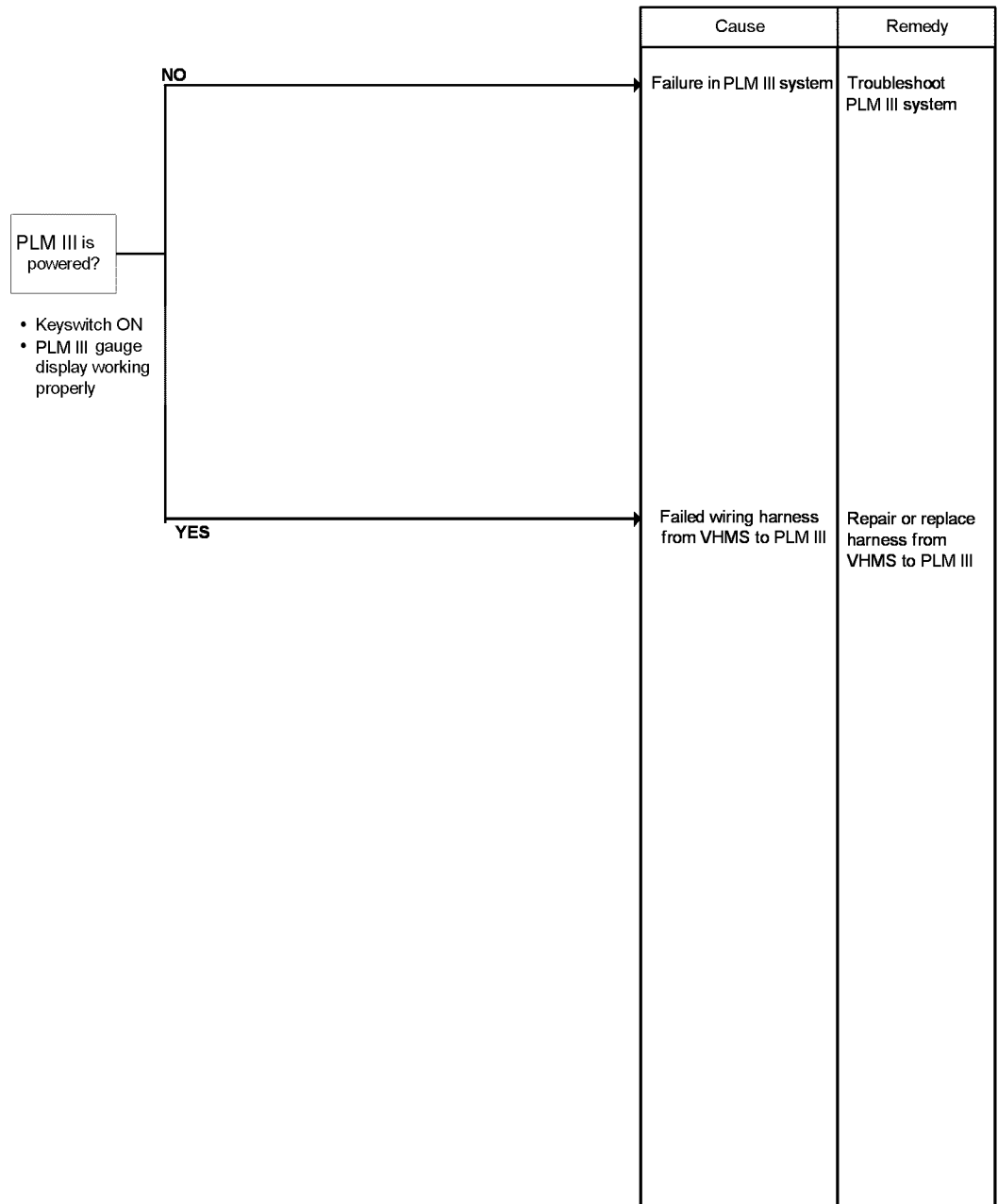

D130010

SECTION E
ELECTRIC PROPULSION SYSTEM
INDEX

ELECTRIC PROPULSION SYSTEM COMPONENTS E2-1

AC DRIVE SYSTEM ELECTRICAL CHECKOUT PROCEDURE E3-1

TROUBLESHOOTING FAULT CODES (A001-A146) E5-1

TROUBLESHOOTING FAULT CODES (A152-A216) E5-1

TROUBLESHOOTING FAULT CODES (A223-A292) E5-1

TROUBLESHOOTING FAULT CODES (A303-A365) E5-1

NOTE: Propulsion system electrical schematics are located in Section "R" of this manual.

**Table 2: DID PANEL FAULT CODES
(Codes Received from PSC)**

EVENT NUMBER	EVENT DESCRIPTION	EVENT RESTRICTION	DETECTION INFORMATION
036	GY19 GRID BLOWER FAILURE	No power	A grid blower has failed.
	:01 blower 1 stall		
	:02 blower 2 stall		
	:03 blower 1 open		
	:04 blower 2 open		
	:05 blower 1 & 2 delta too large		
037	COMPUTER POWER SUPPLY	Speed limit	+5V power supply is out of limits. +15V power supply is out of limits. -15V power supply is out of limits. +24V power supply is out of limits. -24V power supply is out of limits.
	:01 VOLTS 5 POS		
	:02 VOLTS 15 POS		
	:03 VOLTS 15 NEG		
040	VOLTS 24 POS		
041	VOLTS 24 NEG		
042	DIRECTION SELECTED IN LOAD BOX MODE	No propel	Selector switch moved to FORWARD or REVERSE during self load.
043	DRIVE SYSTEM BATTERY LOW	Speed limit	Battery volts are below limit.
044	DRIVE SYSTEM BATTERY HIGH	None	Battery volts are above limit.
045	CHOPPER OPEN CIRCUIT	Speed limit	Open circuit in a chopper Open circuit in chopper 1 Open circuit in chopper 2
	:01 chopper 1		
	:02 chopper 2		
046	RETARD SHORT CIRCUIT	Speed limit & engine speed	Failure during chopper self test. Link voltage decayed too quickly when AFSE command set low, prior to starting test.
047	ENGINE STALL	No power	An engine stall condition has occurred.
048	SHORTED DC LINK	No power	DC link short detected at startup.
051	TACH LEFT REAR	INV1 disable	Input from M1 sensor is out of tolerance. Zero output from sensor with front wheels moving, brake released. High output from sensor with all other wheel speeds at zero.
	:01 zero output with truck moving		
	:02 high output with truck stopped		
052	TACH RIGHT REAR	INV2 disable	Input from M2 sensor is out of tolerance. Zero output from sensor with front wheels moving, brake released. High output from sensor with all other wheel speeds at zero.
	:01 zero output with truck moving		
	:02 high output with truck stopped		
053	TACH LEFT FRONT	SYS Event	Input from left front wheel sensor is out of tolerance. Zero output from sensor with rear wheels moving, brake released. High output from sensor with all other wheel speeds at zero.
	:01 zero output with truck moving		
	:02 high output with truck stopped		
054	TACH RIGHT FRONT	SYS Event	Input from right front wheel sensor is out of tolerance. Zero output from sensor with rear wheels moving, brake released. High output from sensor with all other wheel speeds at zero.
	:01 zero output with truck moving		
	:02 high output with truck stopped		

**Table 4: DID PANEL FAULT CODES
(Codes Received from TCI)**

EVENT NUMBER	EVENT DESCRIPTION	EVENT RESTRICTION	DETECTION INFORMATION	
601	TCI FB144 CPU CARD	No propel	TCI CPU card problem	
	:01 10ms task failed to init			
	:02 20ms task failed to init			
	:03 50ms task failed to init			
	:04 100ms task failed to init			
	:05 200ms task failed to init			
	:06 flt manager task			
	:07 flash CRC			Flash CRC computation did not match expected value.
	:09 main task failed to init			Upon power-up, excessive bus timeouts occurred.
	:10 excess timeouts			
	:11 BBRAM bad			
	:12 BBRAM CRC			CRC on BBRAM did not match expected value.
602	FB104 DIGITAL I/O CARD FAULT	No propel	Internal TCI self-test detected a digital I/O card problem.	
603	FB160 ANALOG I/O CARD FAULT	No propel	Internal TCI self-test detected an analog I/O card problem.	
604	PSC FAULT	Speed limit	Lost RS422 communication with PSC.	
	:01 missing message			
	:02 bad tick			
	:03 bad CRC			
	:04 FIFO overflow			
	:05 bad start bit			
	:06 bad stop bit			
605	AUX BLOWER COMM. FAULT	None	Lost RS422 communication with auxiliary blower controller while auxiliary blower is in failure mode and DC link is not energized.	
607	POSITIVE 5 VOLTS	Speed limit	+5V power supply out of limits	
608	POSITIVE 15 VOLTS	Speed limit	+15V power supply out of limits	
609	NEGATIVE 15 VOLTS	Speed limit	-15V power supply out of limits	
610	POT REFERENCE	Speed limit	Pot reference (10.8V) out of limits	
611	FREQUENCY INPUT	None	Front wheel speed input out of range	
	:01 left front wheel speed		Left front wheel sensor out of range	
	:02 right front wheel speed		Right front wheel sensor out of range	
613	ANALOG INPUT	Speed limit	Signal is outside the design range of valid values.	
	:01 A2D gnd			
	:02 A2D gainchk			
614	BATTERY SEPARATE CONTACTOR FAILURE	SYS Event	Signal is outside the design range of valid values.	
	:01 Battery Separate Failure		Voltage difference greater than 3V	
	:02 crank batt > cntrl batt			
	:03 cntrl batt > crank batt			
616	DIRECTION MISMATCH	No propel	Simultaneous FORWARD and REVERSE commands were received.	

TCI:

1. With the PTU serial cable attached to the TCI port, type `c:\ACNMENU` and press {enter}.
2. Select "PTU TCI and PSC and press {enter}
3. Type your name and press {enter}.
4. Type your password and press {enter}.
5. Cursor to "Special Operation" and press {enter}.
6. Cursor to "Event Data Menu" and press {enter}.
7. Cursor to "View Data Packs" and press {enter}.
8. Type PK number to be recorded and press {enter}.
9. Watch the lower right of the screen as 100 frames are recorded. Press the F2 key.
10. Cursor to "Record Screen" and press {enter}.
11. Assign a file name for the data pack.
12. Press {escape} until back to the DOS "C:>" prompt.
13. Insert a blank disk in the appropriate drive.
14. Type the following command: `copy c:\geohvac\ptuaccu\2data\filename`

NOTE: Insert the name assigned to the file in Step 11 in place of "filename" in the command in Step 14.

15. Press {enter} to copy the file to the disk.

Event Reset

There are two basic types of event resets: *soft* and *hard*. The difference between the soft and hard reset is that a soft reset only affects events that have not been locked out and a hard reset affects events regardless of lockout status.

Events will be reset:

- *On power-up* - A soft reset will be issued against all events at power-up.
- *By DID commands* - The TCI can issue both hard and soft resets.
- *By PTU commands* - The PTU can issue both hard and soft resets.

SERIAL DATA COMMUNICATIONS

The PSC system CPU card uses serial data busses to communicate with the TCI, the PTU, and the two inverter CPU cards.

PSC - TCI Communications Processing

This software function performs the processing necessary for the PSC to communicate with the TCI. The communication is comprised of periodic data and non-periodic data.

Periodic data is a predefined set of data which is used for transferring real time control information from the PSC to the TCI and from the TCI to the PSC at a fixed rate.

The non-periodic messages are used to transfer all background data. Background data consists of DID commands, remote monitor data, and download code.

Packets containing periodic data will be asynchronously (not initiated) transmitted from the PSC to the TCI and from the TCI to the PSC every 200 ms. The TCI initiates the transfer of non-periodic data.

The TCI and the PSC are interfaced using the General Electric Asynchronous Communications Protocol (ACP). ACP provides two general types of messages: *acknowledged* and *unacknowledged*. The acknowledged messages are used to transmit the background data. The unacknowledged messages are used to transmit the periodic data.

PSC - PTU Communications Processing

This software function performs the processing necessary for the PSC to communicate through an RS-232 serial link to the Portable Test Unit (PTU).

SECTION E3
AC DRIVE SYSTEM ELECTRICAL CHECKOUT PROCEDURE
INDEX

AC DRIVE SYSTEM ELECTRICAL CHECKOUT PROCEDURE	E3-3
AC DRIVE SYSTEM MAINTENANCE	E3-3
NORMAL TRUCK SHUTDOWN PROCEDURE.....	E3-4
SHUTDOWN AFTER SYSTEM FAILURE	E3-4
SYSTEM CHECKOUT	E3-5
Battery and Control Circuit Checks - Battery Power OFF	E3-5
Battery and Control Circuit Checks - Battery Power ON	E3-8
Checks with Key Switch OFF	E3-9
Checks with Key Switch ON	E3-9
CPU Battery Checks.....	E3-9
MEMORY BACKUP BATTERY REPLACEMENT	E3-10
TCI PROGRAMMING.....	E3-10
PSC PROGRAMMING	E3-11
INVERTER PROGRAMMING	E3-11
CPU RESET	E3-11
PSC CHECKOUT	E3-12
PSC Digital Input Checks	E3-12
PSC Digital Output Checks.....	E3-16
TCI CHECKOUT.....	E3-17
Modular Mining Communication Port Check	E3-17
TCI Digital Input Checks.....	E3-17
TCI Digital Output Tests	E3-23
CALIBRATIONS	E3-25
Speedometer	E3-25
Accelerator Pedal, Retarder Pedal/Lever and RSC Dial	E3-25

- ◆ Close the “PSC Real Time Data” screen, then double-click “PSC Serial Data”.
- Verify that the analog and digital values are similar to the example in Figure 3-4.

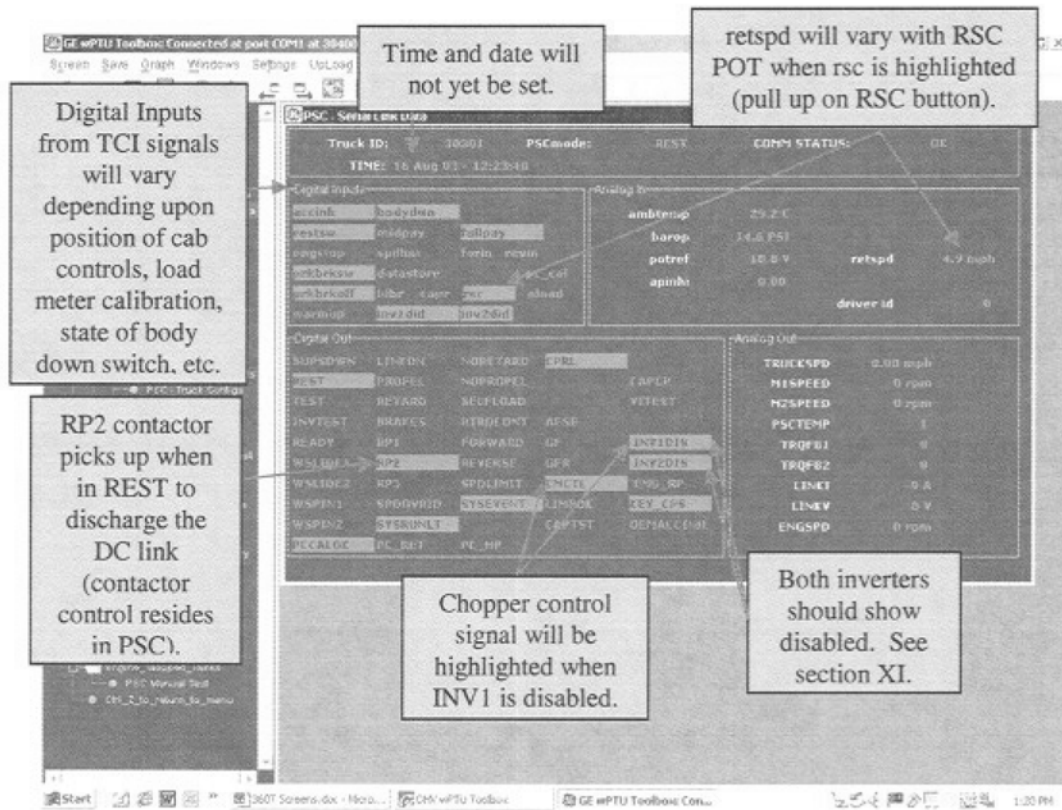

FIGURE 3-4. PSC SERIAL DATA SCREEN

CALIBRATIONS

The following procedures are used to calibrate the retarder and accelerator pedals, retarder lever, and the hydraulic brake temperature and propel system temperature gauges and the speedometer for the software. If any of the above components require replacement during truck servicing or troubleshooting procedures, the new or rebuilt component must be recalibrated using the applicable procedure before the truck is returned to service.

Speedometer

The speedometer can be calibrated by using the DID panel at the back of the operator cab.

1. On the DID panel, press the function keys
F4 - Menu > F1 - Test Menu > F4 - Speedometer.
2. Adjust the speedometer to read 32 kph (20 mph).
3. Enter "40" on the DID panel keypad.
 - Verify that the speedometer reads 64 kph (40 mph).

Accelerator Pedal, Retarder Pedal/Lever and RSC Dial

The pedals and retarder lever can be calibrated by using the DID panel at the back of the operator cab. Press the function keys F4 - Menu > F4 - Truck Cfg > F2 - Begin, then follow the instructions on the screen.

The pedals, retarder lever and RSC dial can also be calibrated by using the PTU as follows:

1. Connect the serial communication cable from the PTU to the PSC port (DIAG1) on the DID panel located on the back wall of the operator cab.
2. Make sure that the directional control lever is in PARK and the rest switch is in the REST position.
3. Turn control power switch (1, Figure 3-1) and the key switch ON.
 - ◆ Click START > Programs > GEOHVPTU_2.0 > AC TOOLS > wPTU AC v21.01
 - ◆ Select "Normal" mode {enter}
 - ◆ Type password "ok75e" {enter}
 - ◆ Under "Real Time", double-click "PSC Real Time Data".
 - Verify the values in Table VI.

TABLE VI. CALIBRATION VALUES

INPUT	DESCRIPTION
ACCEL-SEL	0.00 - accelerator pedal released
	1.00 - accelerator pedal fully depressed
RETRD-SEL	0.00 - retarder pedal released and retarder lever fully up
	1.00 - retarder pedal fully depressed and retarder lever fully up
	1.00 - retarder pedal released and retarder lever fully down
RETSPD	5 - RSC dial pulled up and turned fully counterclockwise
	34 - RSC dial pulled up and turned fully clockwise

ERASING EVENTS

PSC

1. Connect the serial communication cable from the PTU to the PSC port (DIAG1) on the DID panel located on the back wall of the operator cab.
2. Make sure that the directional control lever is in PARK and the rest switch is in the REST position.
3. Turn control power switch (1, Figure 3-1) and the key switch ON.
 - ◆ Click START > Programs > GEOHVPTU_2.0 > AC TOOLS > wPTU AC v21.01
 - ◆ Select "Normal" mode {enter}
 - ◆ Type password "ok75e" {enter}
 - ◆ Click "LOGIN to wPTU Toolbox".
 - ◆ Under the "Special Tasks" heading, double-click "Erase PSC Events".
 - ◆ Click "YES".
 - ◆ Double-click "PSC Event Summary".
 - Only two events should be listed and active: Event 91 (Inverter 1 Cutout) and Event 92 (Inverter 2 Cutout). Investigate any other events that are listed.

SECTION E5

TROUBLESHOOTING FAULT CODES (A001-A146)

INDEX

Fault Code A001: Left front suspension pressure sensor signal is high	E5-3
Fault Code A002: Left front suspension pressure sensor signal is low	E5-4
Fault Code A003: Right front suspension pressure sensor signal is high	E5-5
Fault Code A004: Right front suspension pressure sensor signal is low	E5-6
Fault Code A005: Left rear suspension pressure sensor signal is high	E5-7
Fault Code A006: Left rear suspension pressure sensor signal is low	E5-8
Fault Code A007: Right rear suspension pressure sensor signal is high	E5-9
Fault Code A008: Right rear suspension pressure sensor signal is low	E5-10
Fault Code A009: Incline sensor signal is high	E5-11
Fault Code A010: Incline sensor signal is low	E5-12
Fault Code A011: Payload meter speed sensor signal has failed	E5-13
Fault Code A013: Body up switch has failed	E5-14
Fault Code A014: Payload meter checksum computation has failed	E5-15
Fault Code A016: Payload meter write to flash memory has failed	E5-16
Fault Code A017: Payload meter flash memory read has failed	E5-17
Fault Code A018: Right rear flat suspension cylinder warning	E5-18
Fault Code A019: Left rear flat suspension cylinder warning	E5-20
Fault Code A022: Carryback load is excessive	E5-22
Fault Code A026: Payload meter user select switch has failed	E5-24
Fault Code A027: Payload meter user clear switch has failed	E5-25
Fault Code A101: High pressure detected across an hydraulic pump filter	E5-26
Fault Code A105: Fuel level sensor is shorted to ground, indicating a false high fuel level.	E5-28
Fault Code A107: GE has generated a propel system caution	E5-30
Fault Code A108: GE has generated a propel system temperature caution	E5-32
Fault Code A109: GE has generated a propel system reduced level signal	E5-34
Fault Code A115: Low steering precharge pressure is detected	E5-36
Fault Code A123: GE has generated a reduced retarding caution.	E5-38
Fault Code A124: GE has generated a no propel / no retard warning	E5-40
Fault Code A125: GE has generated a no propel warning.	E5-42
Fault Code A126: Oil level in the hydraulic tank is low	E5-44
Fault Code A127: IM furnished +5 volt output for sensors is low	E5-46
Fault Code A128: IM furnished +5 volt output for sensors is high	E5-48
Fault Code A139, A310: Low fuel level warning.	E5-50
Fault Code A145: Hydraulic temperature sensors cause advance of engine rpm to advance level 2 for cooling of hydraulic oil.	E5-52
Fault Code A146: Hydraulic temperature sensors cause posting of this fault	E5-54

Fault Code A011: Payload meter speed sensor signal has failed

Operator Action	None
Fault Code	A011
Description	Payload meter speed sensor signal has failed.
Fault Conditions	Sets when payload meter declares a speed sensor fault. Resets when payload meter resets the speed sensor fault.
Operator Alerting System Response	PLM Display: -----
Resulting Problem(s)	Payload and haul cycle data is bad.
Related Information	A laptop running "IM Realtime Data Monitor" software may be required to resolve this fault.

Table

1. The primary correction for this fault is to correct any external wiring or replace the GE signal source.
2. Refer to the schematic to identify which item(s) may be causing the parameter(s) to be in the unexpected state. Troubleshoot these items.
3. If this fault is not currently active or if no parameters are currently in the unexpected state and the malfunction is still unresolved, then check each of the parameters in the Table for proper functionality. Troubleshoot all item(s) related to the parameter(s) which are found to be malfunctioning.

Parameter	Expected State and/or Related Fault(s)
Truck Speed Signal (PLM3 15, 25)	7 Hz: truck is not moving Greater than 7 Hz: truck is moving Fault(s): A212

Related circuit diagram

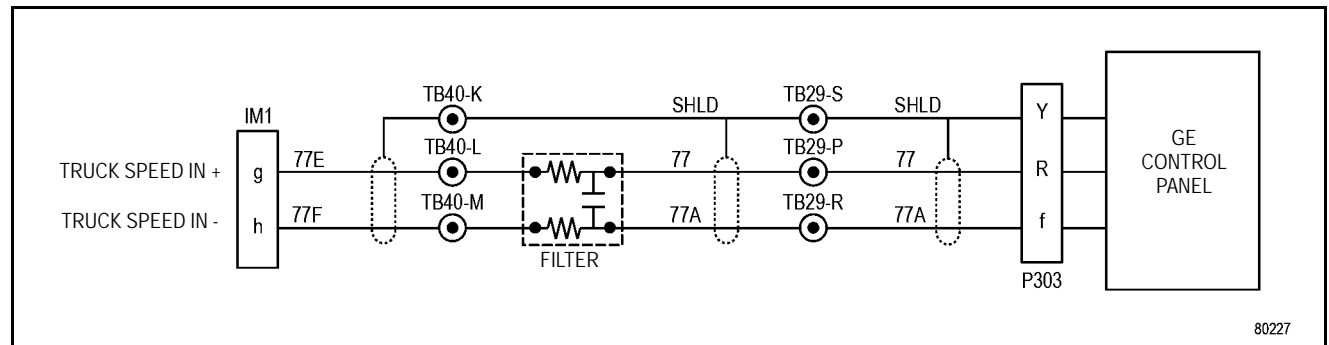

80227

Fault Code A027: Payload meter user clear switch has failed

Operator Action	None
Fault Code	A027
Description	Payload meter user clear switch has failed.
Fault Conditions	Sets if the payload meter detects a switch failure.
Operator Alerting System Response	None
Resulting Problem(s)	Difficulty clearing payload data on the display.
Related Information	

Table

1. The primary corrective measure for this fault is to change / correct the user clear switch and wiring to PLM. No other faults are available to troubleshoot this problem.

Parameter	Expected State and/or Related Fault(s)
User Clear Switch (PLM3 38)	0: Select switch in CLEAR position 1: Select switch in OFF position

Related circuit diagram

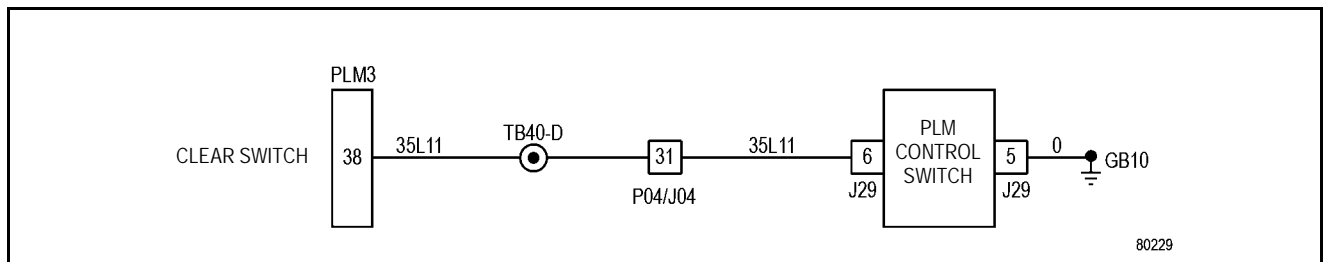

Related circuit diagram

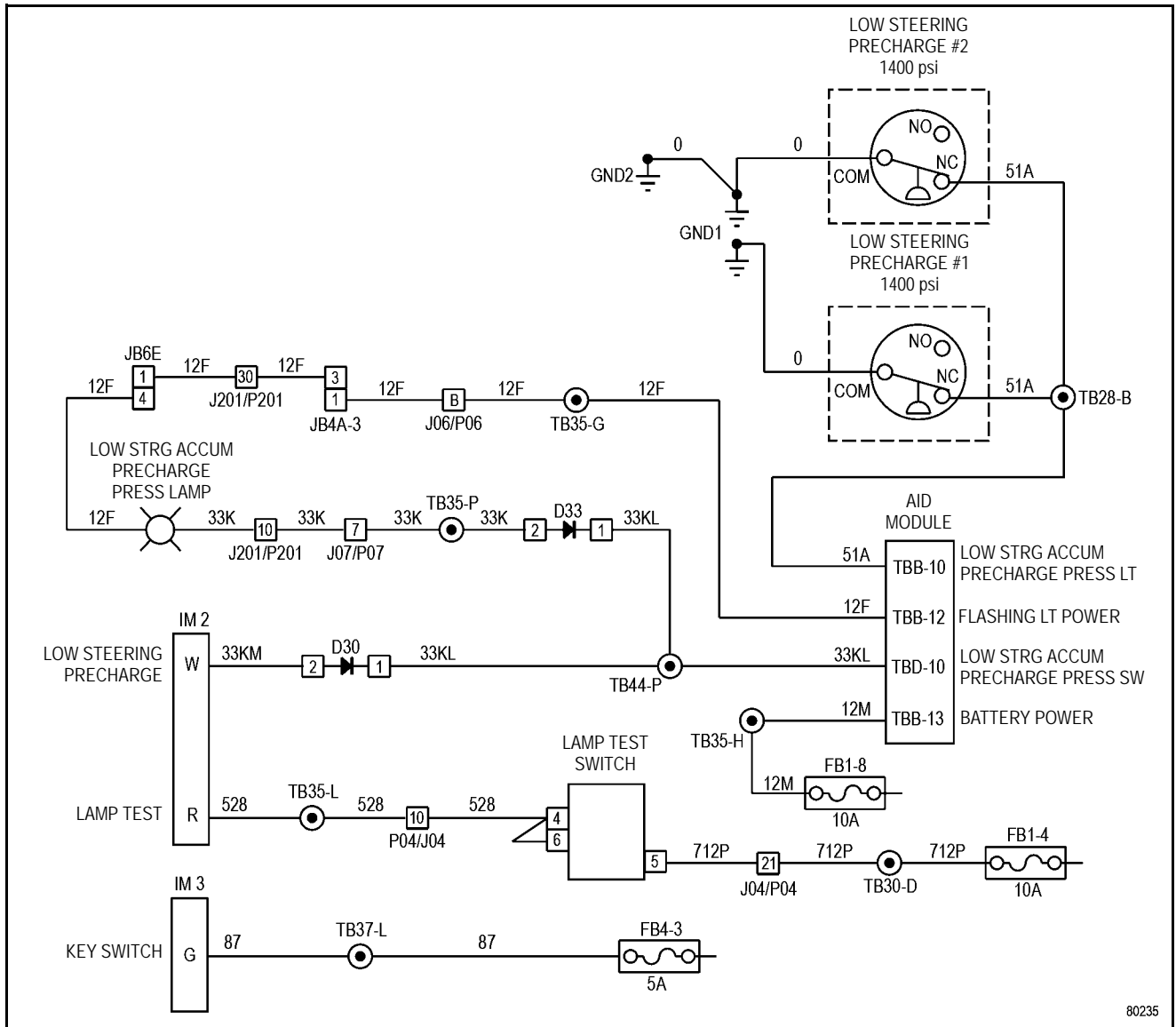

80235

Related circuit diagram

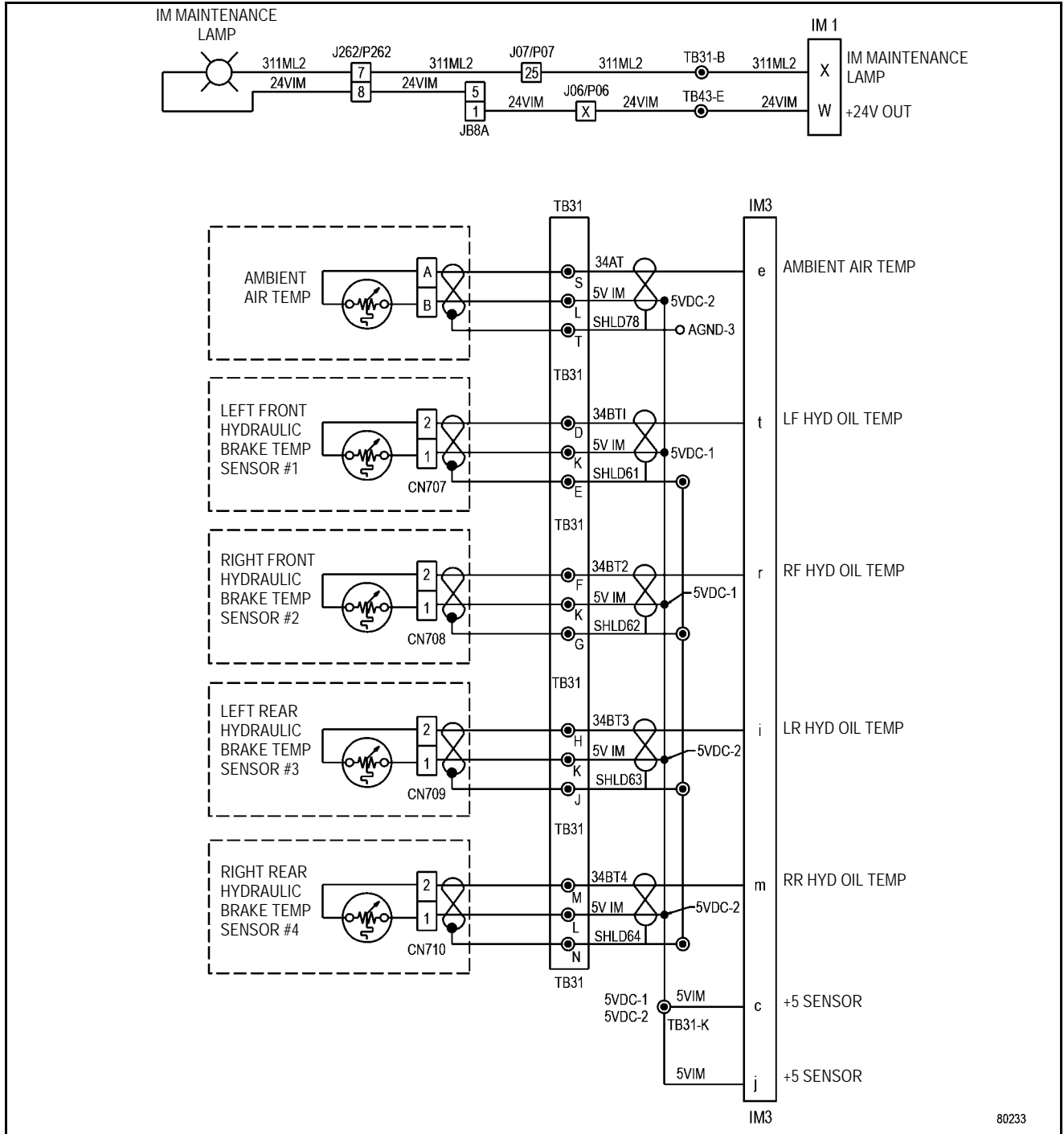

80233

Related circuit diagram

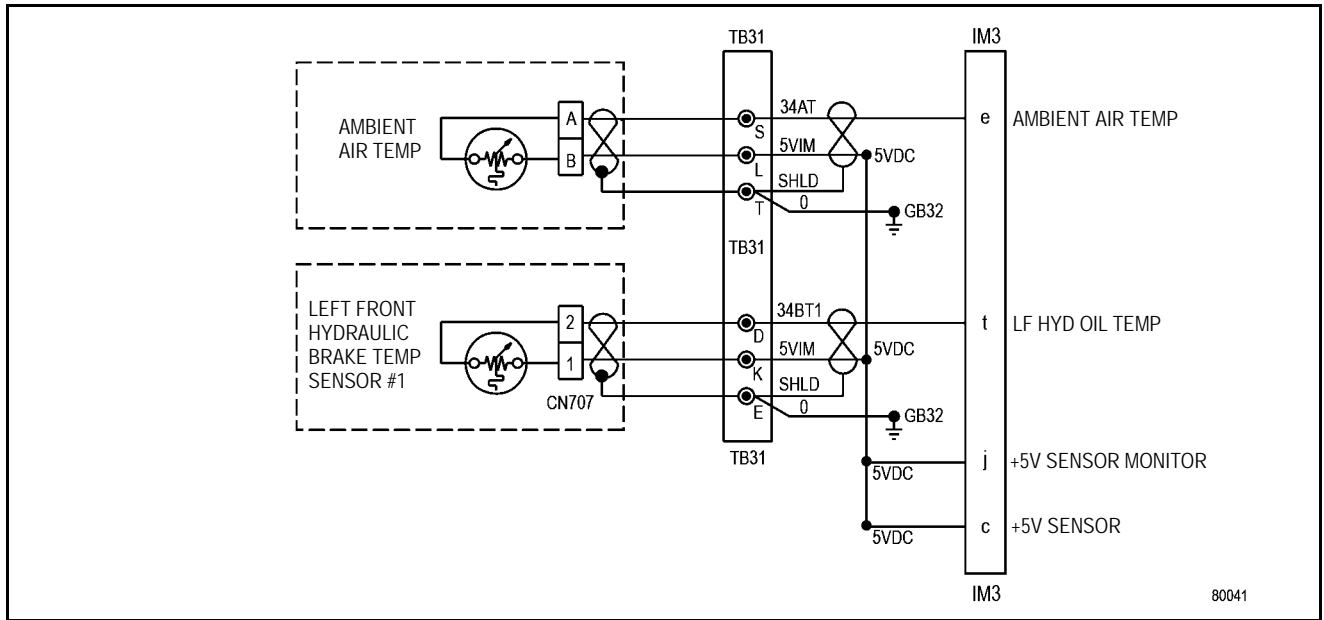

80041

Related circuit diagram

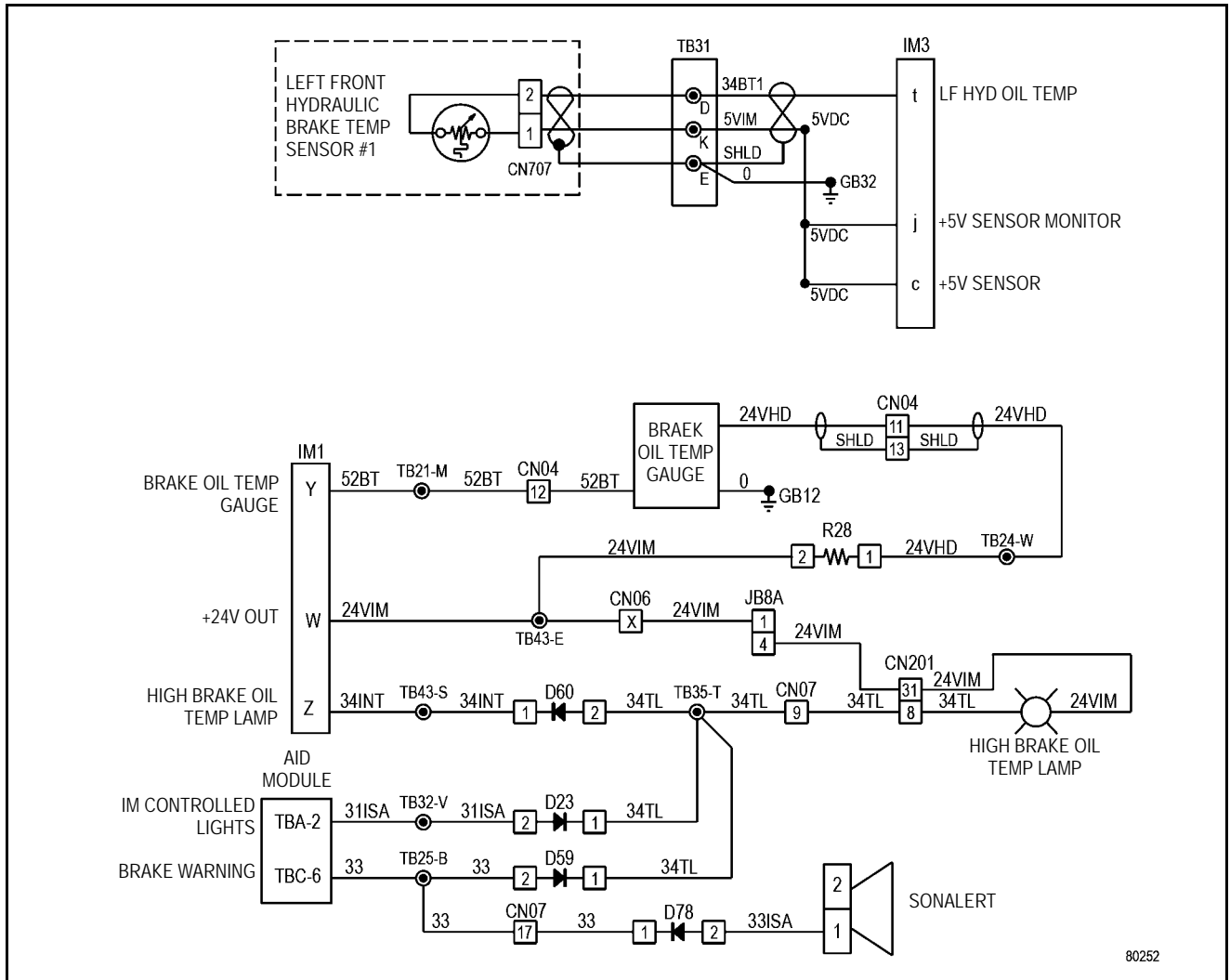

80252

Fault Code A203: Hoist pressure 2 sensor is low

Operator Action	None
Fault Code	A203
Description	Hoist pressure 2 sensor is low.
Fault Conditions	Sets at -401 psi (2.4 mA) for 5 seconds with cranking state not sensed (<600 engine rpm and <18 battery volts). Resets at -206 psi (3.2 mA)
Operator Alerting System Response	None
Resulting Problem(s)	Monitoring of hoist pressures in KOMTRAX Plus will be compromised.
Related Information	A laptop running "IM Realtime Data Monitor" software may be required to resolve this fault.

Table

1. The primary correction for this fault is to correct any external wiring or replace the sensor.
2. This fault's logic contains more than one parameter, each of which may have its own related fault code(s). This fault may be resolved by resolving the parameter(s) active fault code(s). Refer to the Troubleshooting Instructions for the active parameter fault(s).
3. If there are no active parameter fault codes, then based on the truck's setup while this fault is active, determine which of the parameters in the Table is not shown in its expected state on the IM Realtime Data Monitor program. Refer to the schematic to identify which item(s) may be causing the parameter(s) to be in the unexpected state. Troubleshoot these items.
4. If this fault is not currently active or if no parameters are currently in the unexpected state and the malfunction is still unresolved, then check each of the parameters in the Table for proper functionality. Troubleshoot all item(s) related to the parameter(s) which are found to be malfunctioning.

Parameter	Expected State and/or Related Fault(s)
Hoist Pressure 2 Sensor (IM3 q)	2.4 mA to 20.1 mA: good readings Less than 2.4 mA or more than 20.1 mA: Defective sensor or circuit Fault(s): A199
Battery Voltage, 24 Volt (IM1 A)	>18 Volt: Good Reading <18 Volt: Low battery voltage (while cranking) blocks this fault.
Engine Speed [RPM] (CAN/J1939) (IM1 q,r,s)	Less than 600 RPM: combined with low voltage means cranking is in process and fault is blocked Greater than 600 RPM: engine is running normally Fault(s): A184

Related circuit diagram

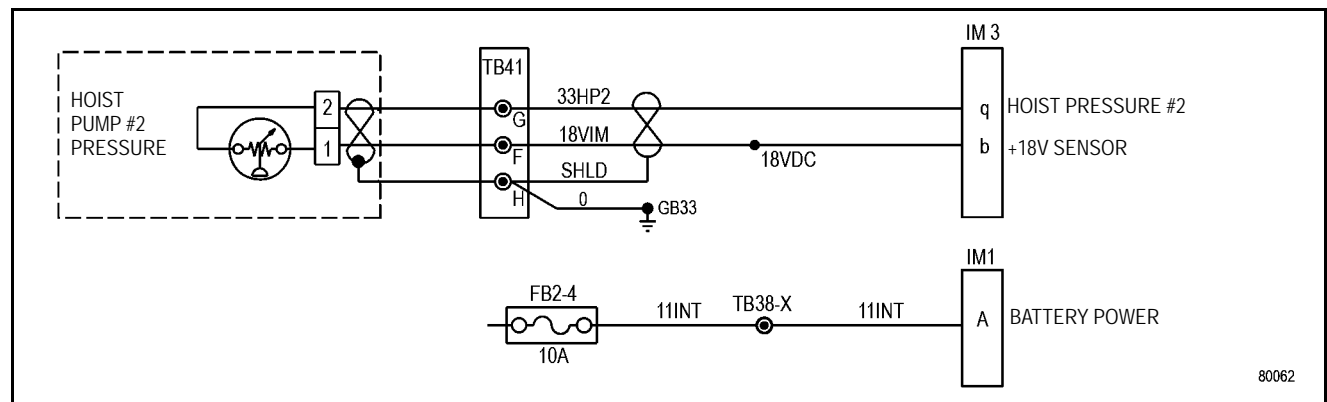

Truck Speed [kph] (IM1 g,h)	0: truck is not moving Greater than 0: truck is moving Fault(s): A212
CAN J1939 connection (IM1 q,r,s)	Fault(s): A184
Keyswitch (IM3 G)	0: keyswitch is off and the truck is not moving and the engine is not running 1: keyswitch is on or the truck is moving or the engine is running Fault(s): A240
Park Brake Solenoid (IM1 E)	Status - Open Load: Unexpected. Troubleshoot. Status - Normal: Expected. No Problem. Status - Shorted to Ground: Expected if shifter is in the forward, neutral, or reverse positions and the engine oil pressure is above the setpoint of the engine oil pressure switch. Otherwise unexpected and must troubleshoot. Status - Overload: Unexpected. Troubleshoot. 0: shifter is not in the forward, neutral, or reverse positions or the engine oil pressure is below the setpoint of the engine oil pressure switch and either the speed of the truck has been 0.8kph or less for 1 second or the service brakes are applied 1: shifter is in the forward, neutral, or reverse positions and the engine oil pressure is above the setpoint of the engine oil pressure switch Fault(s): A216, A351

Related circuit diagram

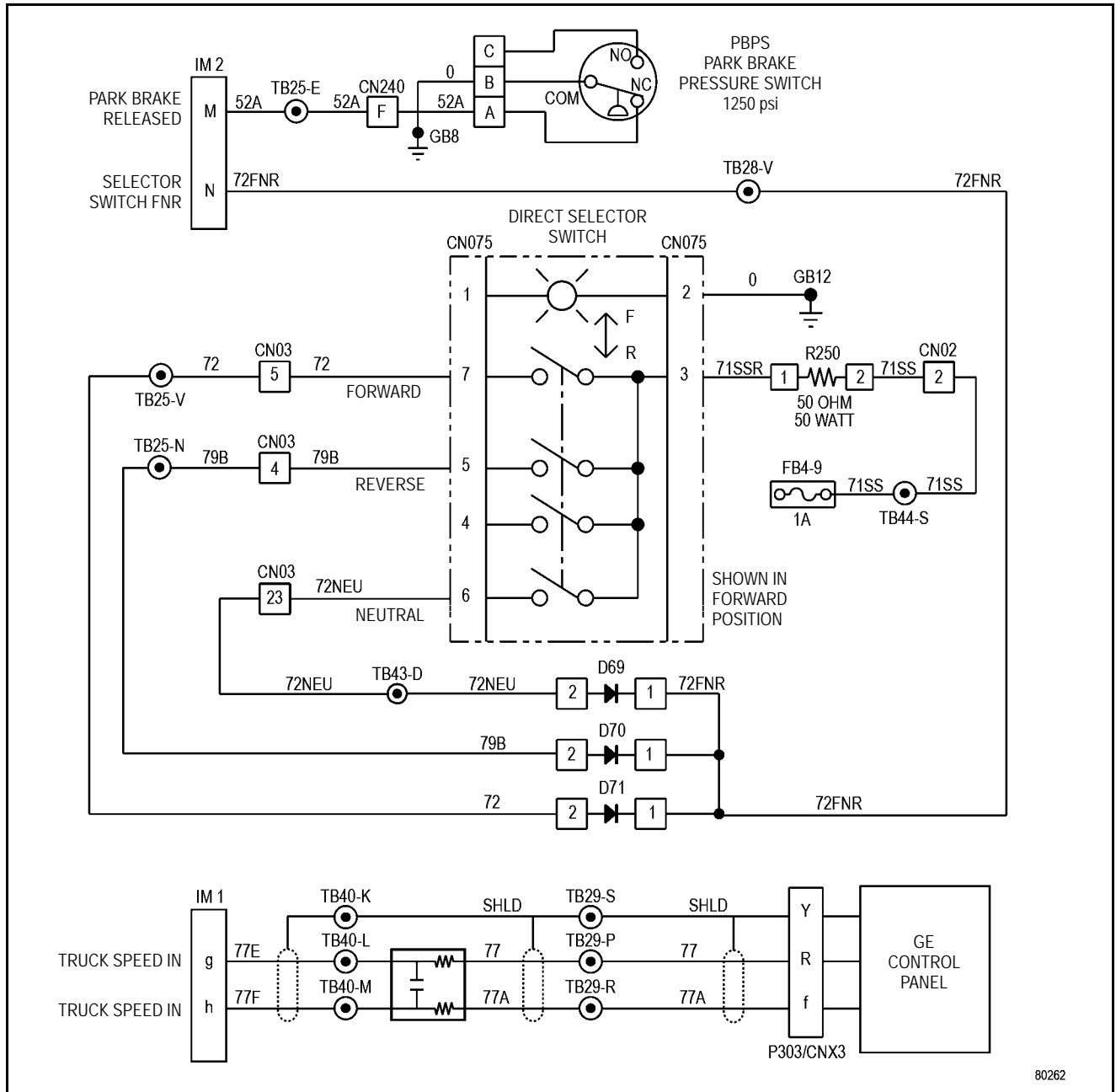

80262

Related circuit diagram

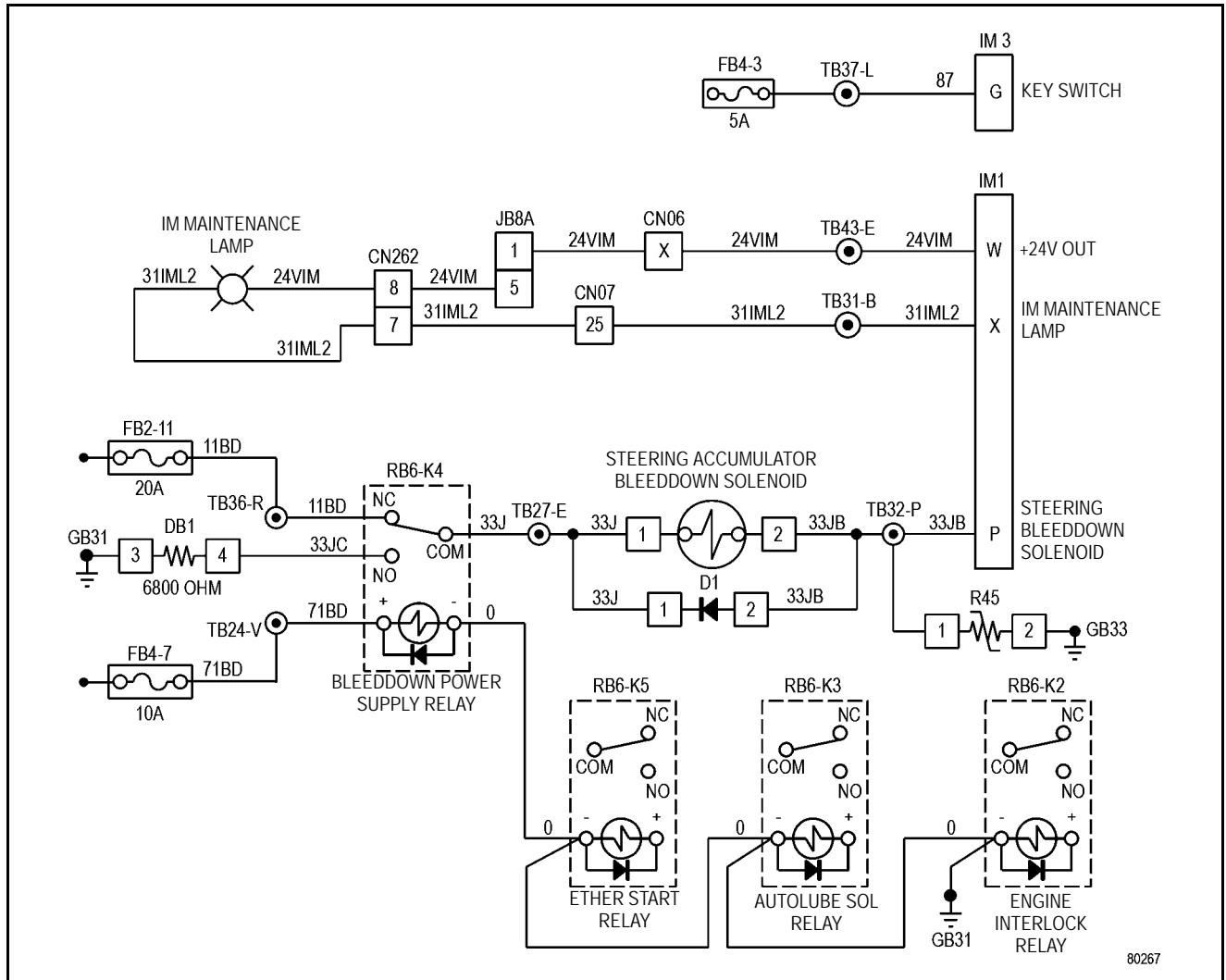

80267

Related circuit diagram

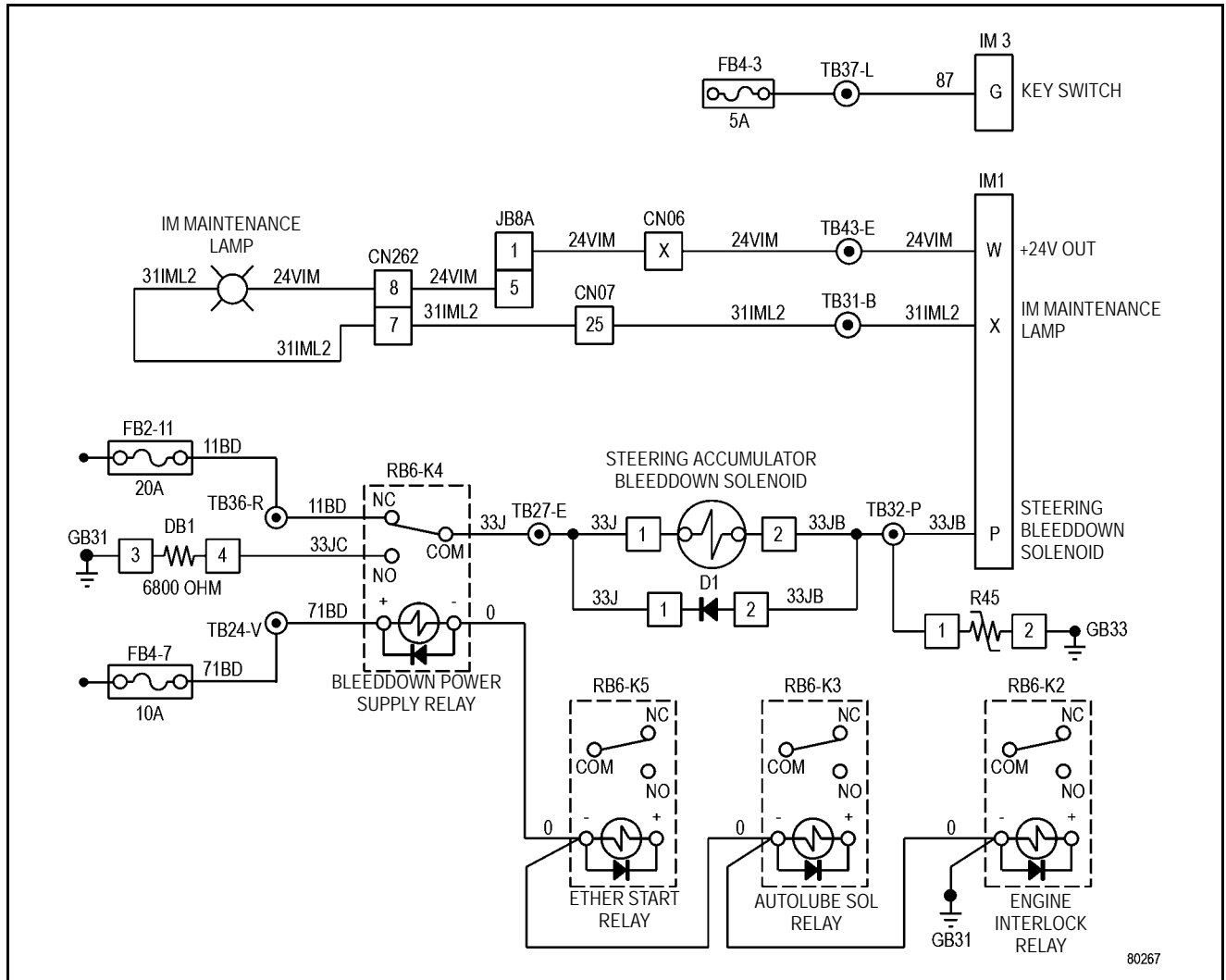

80267

NOTES

Related circuit diagram

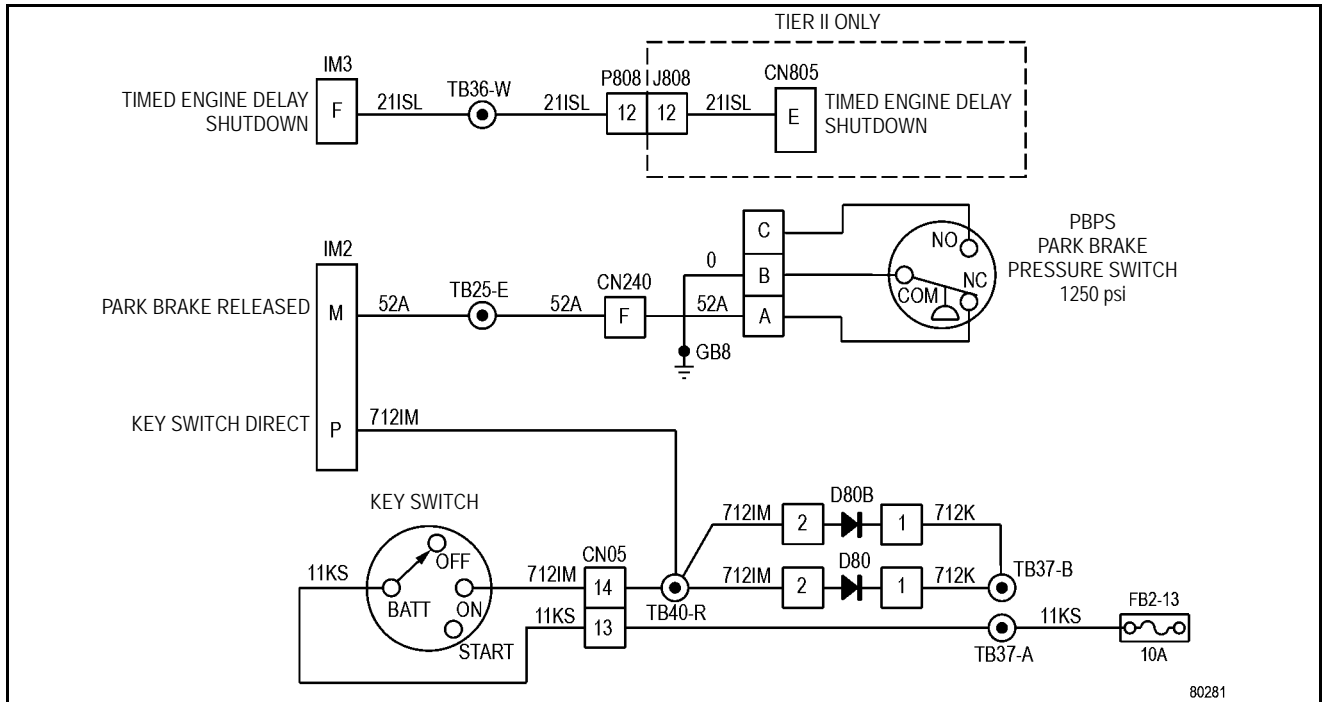

80281

Related circuit diagram

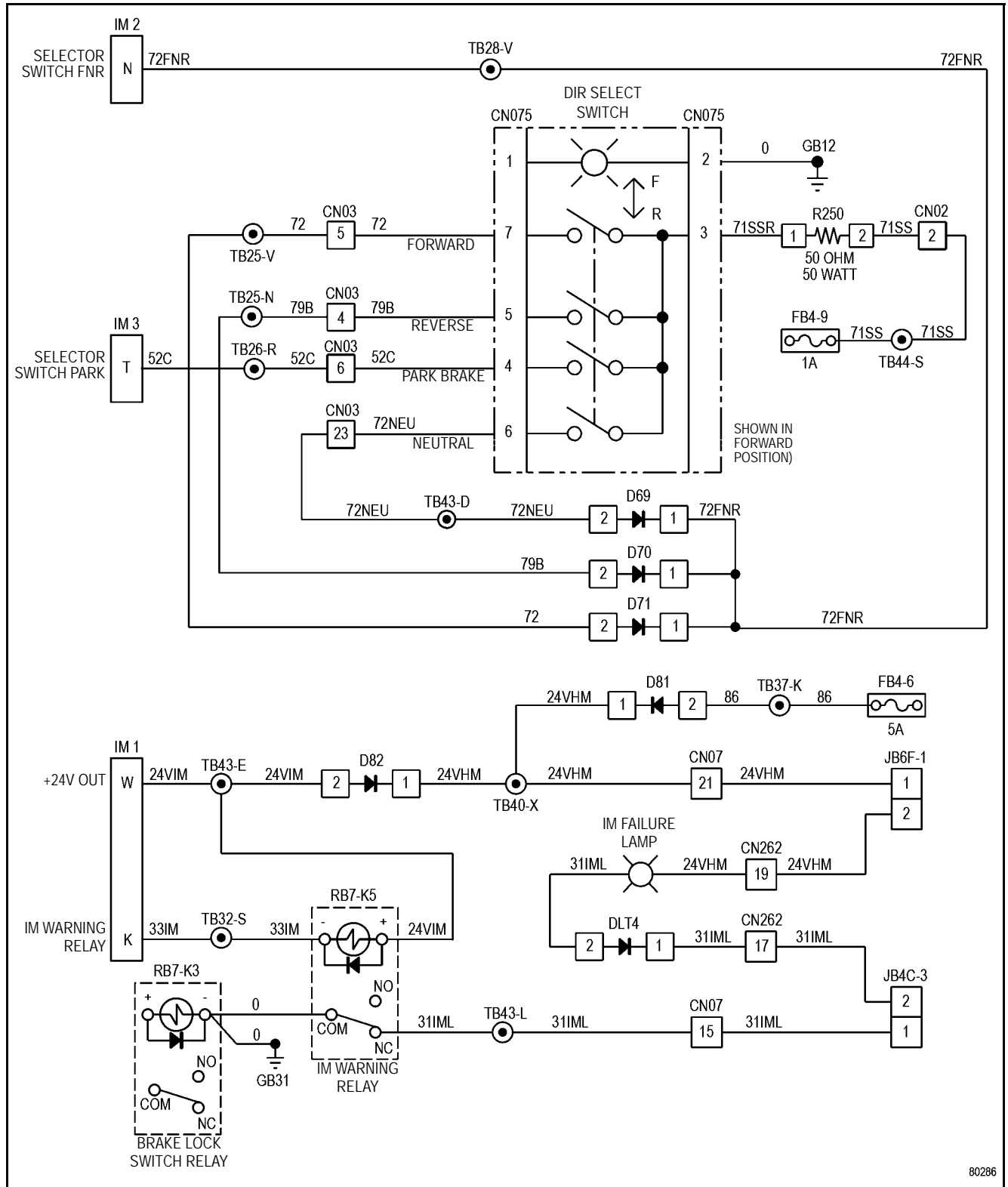

80286

Related circuit diagram

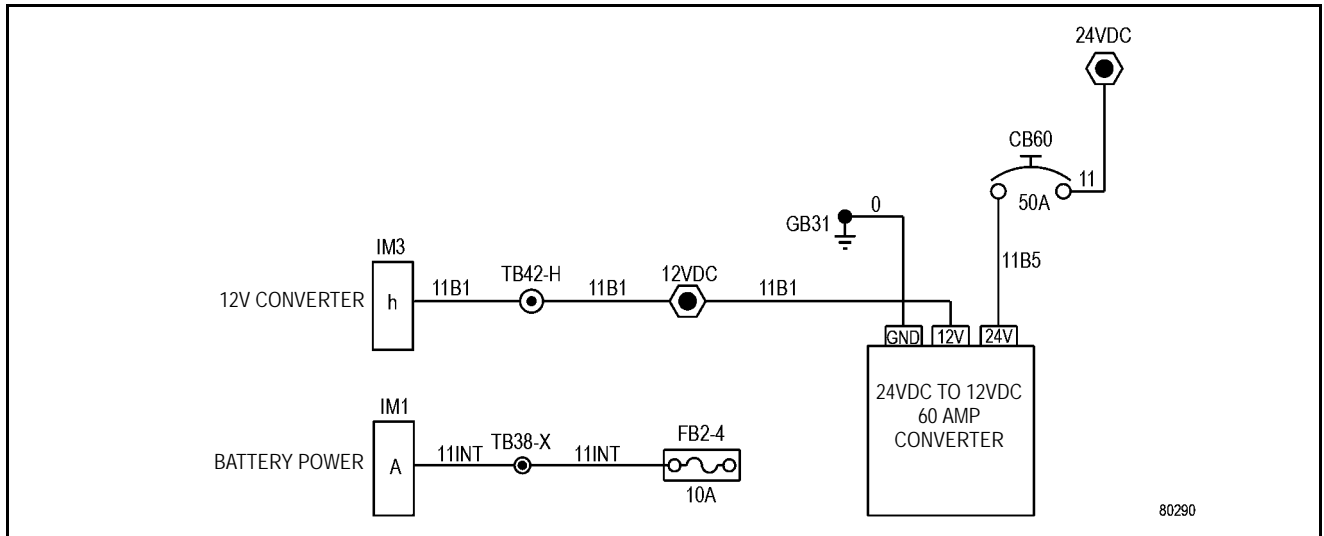

CLICK HERE TO **DOWNLOAD** THE COMPLETE MANUAL

- Thank you very much for reading the preview of the manual.
- You can download the complete manual from: www.heydownloads.com by clicking the link below



- Please note: If there is no response to CLICKING the link, please download this PDF first and then click on it.

CLICK HERE TO **DOWNLOAD** THE COMPLETE MANUAL

Related circuit diagram

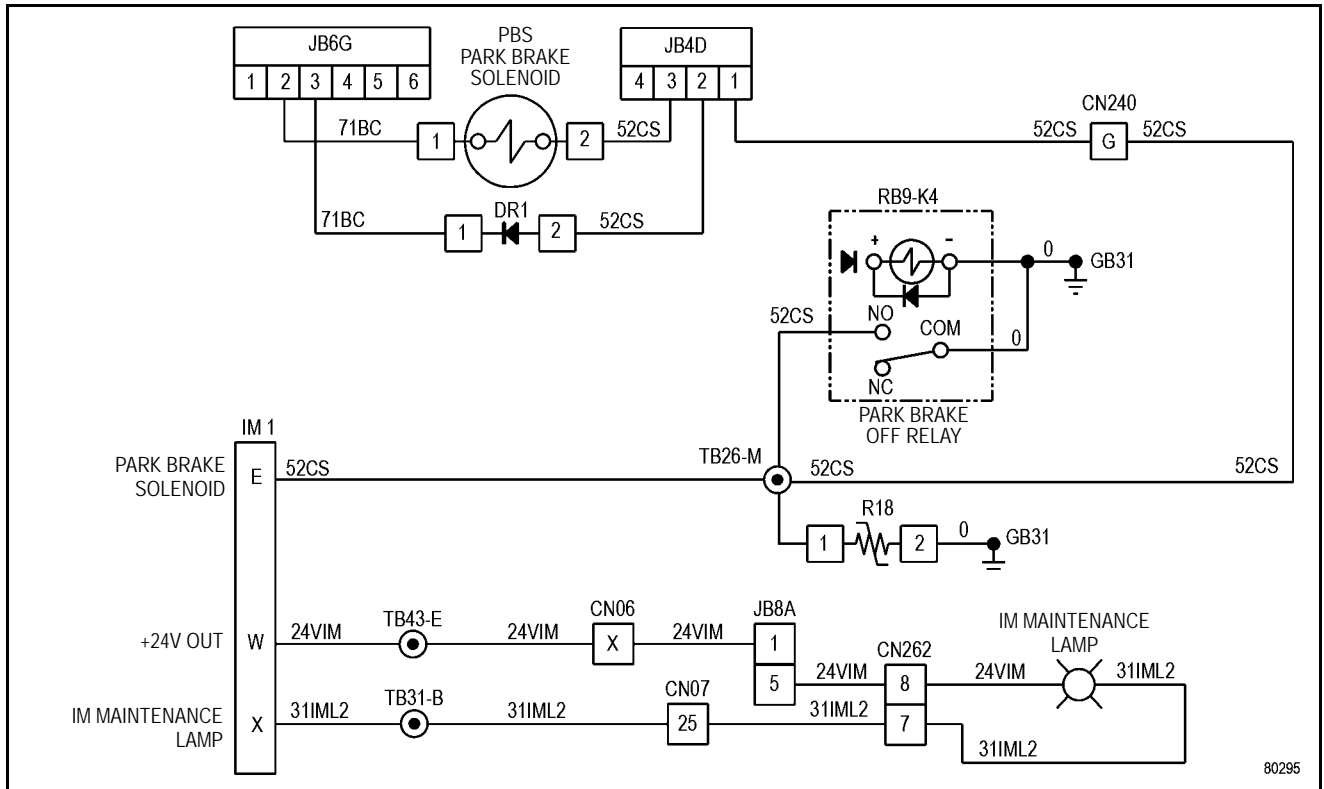

80295

Related circuit diagram

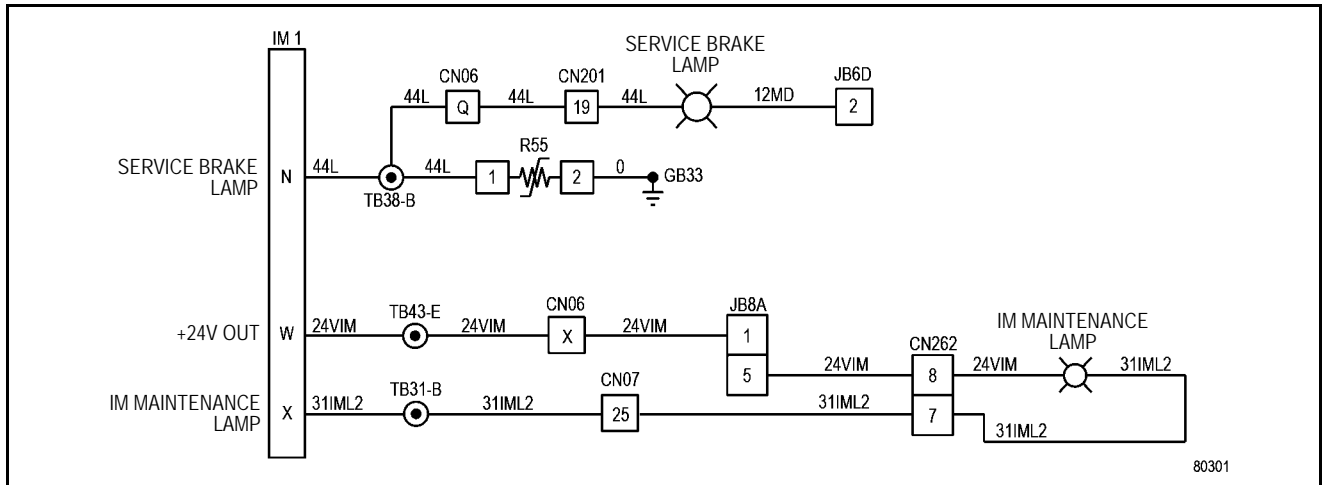

NOTES

FRONT TIRES AND RIMS

Removal

1. Apply parking brake and block rear wheels to prevent movement of truck.
2. Following normal shutdown procedures, place the rest switch in the ON position, shut down the engine and verify that the link voltage lights are OFF. Allow at least 90 seconds for the accumulators to bleed down. Turn the steering wheel to ensure that no pressure remains. As a safety precaution, bleed down the brake accumulators.
3. Place a jack under the spindle or frame at the front cross tube.
4. Raise the front end of the truck until the tire clears the ground. Block up the truck securely under the frame.
5. Inspect the hydraulic brake lines for damage or leaking fittings.

6. Grip the tire and wheel assembly with tire a handler. Remove nuts (11, Figure 2-3) that secure the wheel assembly.
7. Be careful not to damage the inflation hose during tire removal. Move the wheel assembly away from the wheel hub and into a clean work area.

WARNING

Do not attempt to disassemble wheel assembly until all air pressure is bled off.

Always keep personnel away from a wheel assembly when it is being removed or installed.

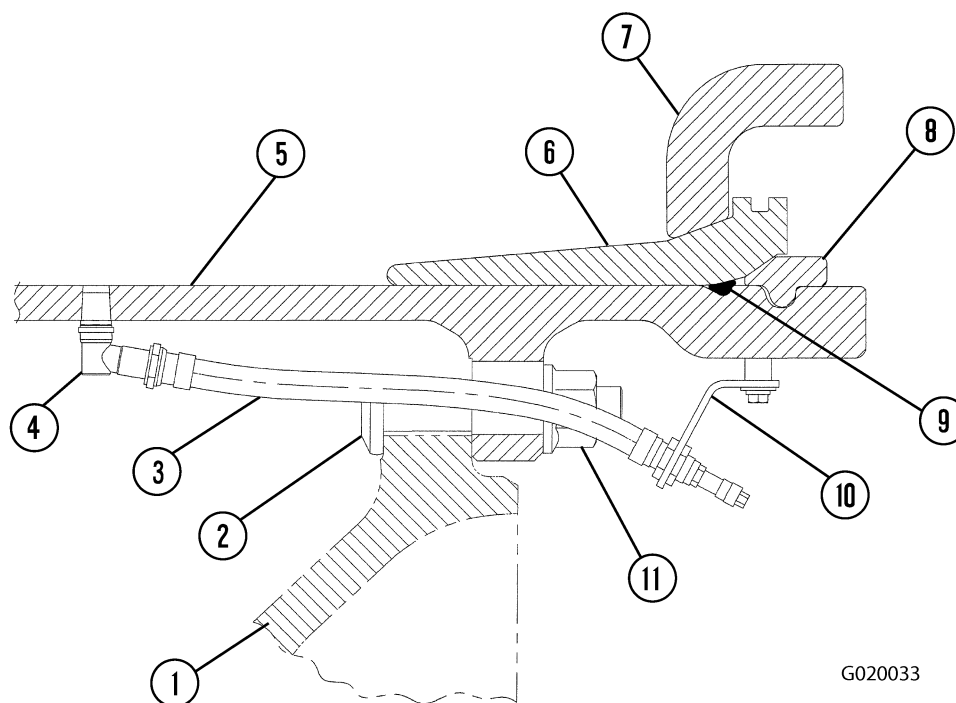

FIGURE 2-3. FRONT WHEEL HUB AND RIM ASSEMBLY

- | | | |
|------------------------|-------------------|-------------------|
| 1. Wheel Hub | 5. Rim | 9. O-Ring |
| 2. Stud | 6. Bead Seat Band | 10. Clamp Bracket |
| 3. Tire Inflation Hose | 7. Side Flange | 11. Flanged Nut |
| 4. Swivel Connector | 8. Lock Ring | |

4. After the pusher tool has been installed, progressively increase the torque on the cap screws in a circular pattern until the tapered piston breaks loose, or until the maximum specified torque on the cap screws of **2 142 N·m (1,580 ft lb)** is reached.
5. If the specified torque is reached and the parts have not separated, slightly loosen the cap screws and slowly and uniformly apply heat to the spindle as shown (3, Figure 3-6). Heat must be applied in two locations 180 degrees apart. Allow heat to penetrate into the spindle. Reapply heat as required. **Do not exceed 454 °C (850 °F) anywhere on the spindle.**

6. Tighten the cap screws again to the maximum specified torque as described in Step 4.
7. Using a large hammer and heat at the specified locations, carefully tap on the top surface of the spindle until the piston breaks free.

NOTE: In extreme cases, it may be necessary to remove additional steering arm retaining cap screws and use additional pusher cap screws to apply more force.

8. After separation, use the lifting device to move the spindle assembly to clean work area for repair.

⚠ CAUTION

Heating the spindle in excess of 454° C (850° F) may cause serious damage to the spindle.

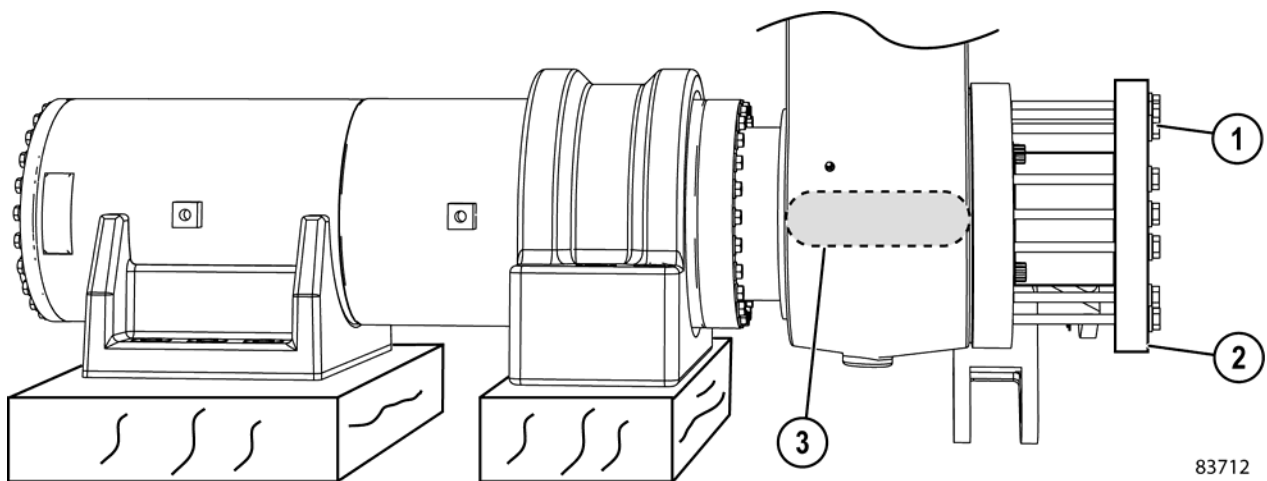

83712

FIGURE 3-6. PUSHER TOOL INSTALLATION

- | | |
|-----------------------|-----------------|
| 1. Cap Screw & Washer | 3. Area to heat |
| 2. Pusher Tool | |

TIE ROD

Removal

1. With engine shut down and key switch OFF, allow at least 90 seconds for the accumulator to bleed down. Turn the steering wheel to ensure no hydraulic pressure is present.
2. Block front and back of rear wheels to prevent truck movement.
3. The tie rod weighs approximately 165 kg (364 lb). Attach a suitable lifting device that can handle the load safely to the tie rod and take up the slack.
4. Remove locknuts (8, Figure 3-12), retainers (7), and cap screws (1) from both ends of the tie rod.
5. Remove pins (2) from each end of the tie rod and move them to a clean work area. Bearing spacers (4) will be free when the pin is removed. **Ensure the bearing spacers do not drop out and become damaged when removing the pin.**
6. Use the lifting device to lift the tie rod from the truck.
7. Remove seals (3), spacers (4) and washer (6).

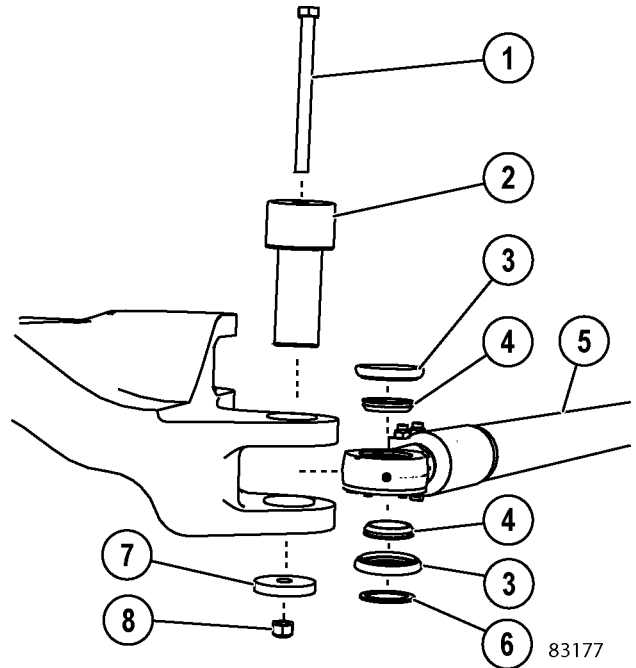

FIGURE 3-12. TIE ROD INSTALLATION (TYPICAL)

- | | |
|--------------|---------------------|
| 1. Cap Screw | 5. Tie Rod Assembly |
| 2. Pin | 6. Washer |
| 3. Seal | 7. Retainer |
| 4. Spacer | 8. Locknut |

Installation

1. The tie rod (5, Figure 3-12) weighs approximately 165 kg (364 lb). Use a suitable lifting device to lift the tie into position on the truck.

NOTE: Ensure both bearing retainers are installed facing downwards, and the tie rod clamping bolts are facing to the rear of the truck.

2. Align bearing spacers (4), seals (3) and washers (6) with the pin bores on both steering arms.
3. Install pins (2), cap screws (1) and retainers (7) and secure with locknuts (8).
4. Tighten both locknuts (8) to **1 017 ± 102 N·m (750 ± 75 ft lb)**.
5. Connect the grease lines to their respective ports. Operate the steering and check for proper operation.
6. Perform the toe-in adjustment procedure.

Disassembly

1. Remove retainer rings (7, Figure 4-4) from the bores of both ends of anti-sway bar (11).
2. Press out spherical bearings (8).

Cleaning and Inspection

1. Inspect the bearing bores of the anti-sway bar. If the bores are damaged, repair or replace the anti-sway bar.
2. Inspect bearing spacers (6) for damage or wear. Replace as needed.

Assembly

1. Press new bearings into the anti-sway bar.
2. Install retainer rings (7). Make sure that the rings are properly seated in the grooves.

Installation

1. Place pin (4, Figure 4-4) into position at the front of the frame mount. Push the pin through spacer (6), and rotate the pin to align retaining capscrew (9) hole with the hole in mounting structure (1).
2. Raise the anti-sway bar into position. The weight of the anti-sway bar is 147 kg (325 lbs).
3. Install capscrew or shoulder bolt (2) and locknut (3).
 - For a capscrew, tighten the locknut to **135 Nm (100 ft lb)**.
 - For a shoulder bolt, tighten the locknut to **68 Nm (50 ft lb)**.
4. Repeat the previous steps to install the remaining pin and spacers at the opposite end of the anti-sway bar. Start the pin into the bore of the axle housing mount from the rear of the truck.
5. Attach the lubrication lines. Pump grease into the bearing to verify that the line and the system are operational.
6. Remove the blocking from between the frame and the axle housing.
7. If necessary, recharge the suspensions. Refer to Section H, Oiling and Charging Procedures.

CAUTION

High tightening force is required to install the cap screws that secure the wheel motors to the rear axle housing. Repeated tightening will result in cap screw fatigue and damage.

Do not reuse any wheel motor mounting hardware (cap screws and hardened washers). Replace the hardware after one use.

Do not retighten any wheel motor mounting cap screw that has loosened after the truck has been placed into operation. If any wheel motor mounting cap screw has loosened during truck operation, all of the cap screws and hardened washers must be replaced with new hardware.

The cap screws that are used to secure the wheel motors to the rear axle housing are specially hardened to meet or exceed Grade 8 specifications. Replace these cap screws with only new cap screws of the correct hardness. Refer to the appropriate parts book for the correct part number.

The use of dry threads in this application is not recommended. Due to the high tightening force that is required to install the wheel motor mounting cap screws, dry threads may cause damage to tools, cap screws or the rear axle housing.

Komatsu does not recommend the use of special friction-reducing lubricants, such as Copper Coat, Never-Seez[®] or other similar products, on the threads of standard fasteners where standard torque values are applied. The use of special friction-reducing lubricants will significantly alter the clamping force during the tightening process. If a special friction-reducing lubricant is used, excessive stress and possible breakage of the fasteners may result.

8. Select the hardware to be installed in Group 1 of the tightening sequence. Refer to Figure 5-8.

Inspect each cap screw for rust, corrosion and surface defects on any seat or thread. Do not use any cap screw if a defect is suspected.

9. Lubricate the cap screw threads, cap screw head seats and washer faces with a multi-purpose grease with a minimum of 5% molybdenum disulphide.

NOTE: The special hardened washers that are used in this application may have a punch lip on one side due to the manufacturing process. When placing this washer under the cap screw head, the washers must be installed with the punch lip facing away from the cap screw head to prevent damage to the fillet between the cap screw head and the shank. Refer to Figure 5-7.

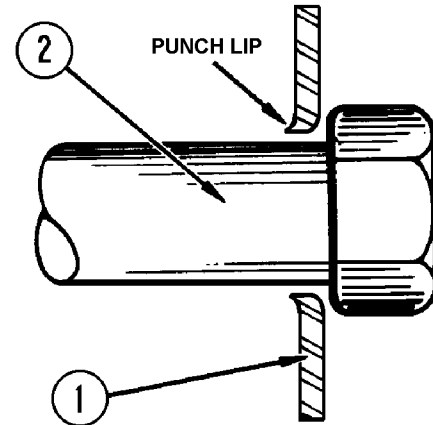

90011

FIGURE 5-8. INSTALLATION OF HARDENED WASHER

1. Washer 2. Cap Screw

10. Install the hardware for Group 1. Tighten each cap screw to **542 N·m (400 ft lb)**.
11. Repeat steps 8 - 10 for each remaining group in the tightening sequence. Refer to Figure 5-8.

FRONT SUSPENSION

Hydrair® II suspensions are hydro-pneumatic components containing oil and nitrogen gas. The oil and gas in the four suspensions carry the gross truck weight less wheels, spindles and rear axle assembly.

The front suspension cylinders consist of two basic components: a suspension housing attached to the truck frame and a suspension rod attached to the front spindle.

Check valves and orifice dampening holes control suspension travel to provide good ride qualities on haul roads under loaded and empty conditions.

The front suspension rods also act as kingpins for steering the truck.

The Hydrair® II suspension cylinder requires only normal care when handling as a unit. However, after being disassembled, these parts must be handled carefully to prevent damage to the machined surfaces. Surfaces are machined to extremely close tolerances and are precisely fitted. All parts must be completely clean during assembly.

Removal

1. Remove the front wheel and tire. Refer to Section G2, Tires and Rims.
2. Remove the front wheel hub and spindle. Refer to Section G3, Front Wheel Hub and Spindle.
3. Remove the boot clamp and boot from the front suspension.



Wear a face mask or goggles. Make sure that only the swivel nut (small hex) turns. Turning the entire charging valve body (large hex) may result in the valve assembly being forced out of the suspension by the gas pressure inside.

4. Discharge the nitrogen pressure from the suspension as follows:
 - a. Remove the cap from charging valve (2, Figure 2-1).
 - b. Turn swivel nut (small hex) (3) counterclockwise three full turns to unseat the valve seal. **DO NOT** turn more than three turns. **DO NOT** turn charging valve body (large hex) (4).
 - c. Depress the valve stem until all nitrogen pressure has been relieved.

5. After all nitrogen pressure has been relieved, loosen charging valve body (4) and remove the charging valve assembly. Discard the O-ring seal.
6. Remove pressure sensor (1) from the charging valve block.

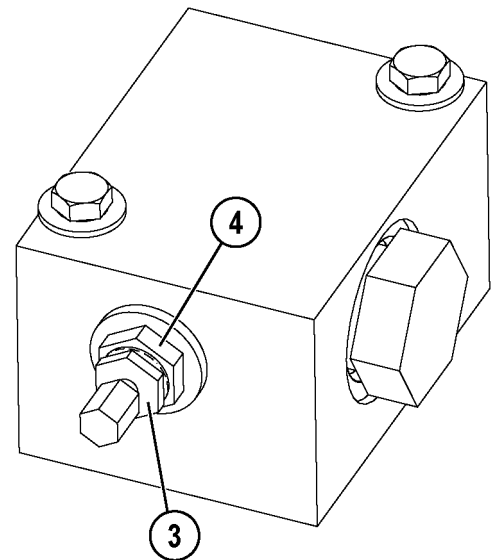
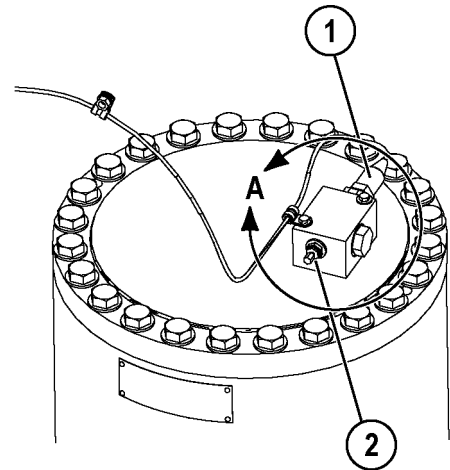

DETAIL A

63222

FIGURE 2-1. SUSPENSION CHARGING VALVE

- | | |
|---------------------------|------------------------------------|
| 1. Pressure Sensor | 4. Charging Valve Body (Large Hex) |
| 2. Charging Valve | |
| 3. Swivel Nut (Small Hex) | |

**SECTION H3
REAR SUSPENSIONS
INDEX**

REAR SUSPENSIONS	H3-3
SUSPENSION CYLINDER	H3-4
Removal	H3-4
Installation	H3-6
Disassembly	H3-6
Cleaning and Inspection	H3-7
Assembly	H3-7
SUSPENSION PRESSURE TEST	H3-9

SUSPENSION OILING AND CHARGING PROCEDURE

GENERAL

These procedures cover the oiling and charging of Hydrair® II suspensions on Komatsu electric drive dump trucks.

Suspensions which have been properly charged will provide improved handling and ride characteristics while also extending the fatigue life of the truck frame and improving tire wear.

NOTE: Inflation pressures and exposed piston lengths are calculated for a normal truck gross vehicle weight (GVW). Additions to truck weight by adding body liners, tailgates, water tanks, etc, should be considered part of the payload. Keeping the truck GVW within the specification shown on the grade/speed chart in the operator cab will extend the service life of the truck main frame and allow the suspensions to produce a comfortable ride.



All Hydrair® II suspensions are charged with compressed nitrogen gas with sufficient pressure to cause injury and/or damage if improperly handled. Follow all safety instructions, cautions, and warnings provided in the following procedures to prevent any accidents during oiling and charging.

Proper charging of Hydrair® II suspensions requires that three basic conditions be established in the following order:

1. The oil level must be correct.
2. The suspension piston rod extension for nitrogen charging must be correct.
3. The nitrogen charge pressure must be correct.

For best results, Hydrair® II suspensions should be charged in pairs (fronts together and rears together). If rear suspensions are to be charged, the front suspensions should be charged first.

NOTE: For longer life of suspension components, a friction modifier should be added to the suspension oil. See the Specifications Charts at the end of this section.

NOTE: Setup dimensions in the Specifications Charts must be maintained during oiling and charging procedures. However, after the truck has been operated, these dimensions may vary.

EQUIPMENT LIST

- Hydrair® Charging Kit
- Jacks and/or Overhead Crane
- Support Blocks for:
 - Oiling Height Dimensions (Front and Rear)
 - Charging Height Dimensions (Front Only)
- Hydrair® Oil (see Specifications Chart)
- Friction Modifier (see Specifications Chart)
- Dry Nitrogen (see Specifications Chart)

If both the front and rear suspensions are to be serviced at the same time, service the front suspensions first. Do not remove the front suspension nitrogen charging blocks until after the rear suspensions have been completely serviced

**SECTION J2
BRAKE CIRCUIT
INDEX**

SERVICE BRAKE CIRCUITJ2-3

PARKING BRAKE CIRCUITJ2-5

BRAKE LOCK CIRCUITJ2-5

SECONDARY BRAKING AND AUTOMATIC APPLYJ2-6

WARNING CIRCUITJ2-6

Disassembly

1. If not already removed, remove electronic retard pedal (16, Figure 3-3) from the brake pedal by removing pivot shaft (8).

NOTE: During disassembly, precision machined parts should be ink marked or tagged to ensure proper reassembly and minimize adjustment time. All items must be placed back into the bores from which they were removed.

- | | |
|---------------------|-----------------------------|
| 1. Brake Valve | 16. Electronic Retard Pedal |
| 2. Retainer Clip | 17. Brake Pedal Actuator |
| 3. Pivot Shaft | 18. Spring Pivot (Lower) |
| 4. Bushings | 19. Spring |
| 5. Shims | 20. Spring Pivot (Top) |
| 6. Retainer Clip | 21. Set Screw |
| 7. Nylon Bearing | 22. Jam Nut |
| 8. Pivot Shaft | |
| 9. Shim | |
| 10. Jam Nut | |
| 11. Capscrew | |
| 12. Pedal Structure | |
| 13. Pad | |
| 14. Nut | |
| 15. Capscrew | |

2. Match mark each section of the brake valve before disassembly.
3. Drain the oil from all ports of the brake valve by rotating the valve over a suitable container.
4. Secure the brake valve in an upright position in a vice.
5. Remove brake pedal actuator (17) by removing retainer clips (2), then removing pivot shaft (3) with a punch and hammer.

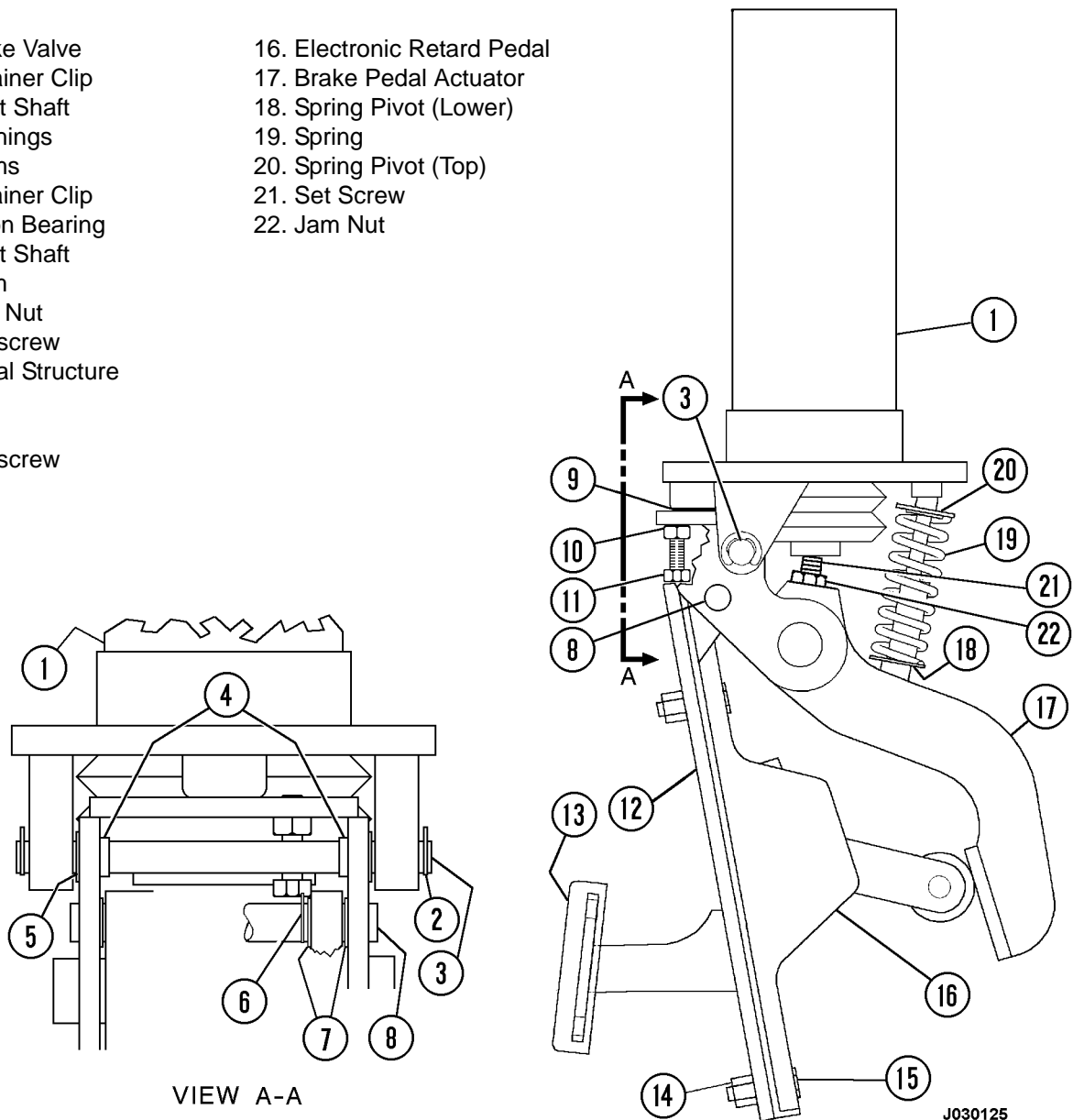

FIGURE 3-3. BRAKE VALVE WITH RETARD PEDAL

DUAL RELAY VALVE BENCH TEST AND ADJUSTMENT

The following parts and test equipment will be required to completely bench test the dual relay valve.

- Four 20 680 kPa (3,000 psi) pressure gauges
- Hydraulic pressure supply, regulated to 18 960 kPa (2,750 psi)
- Hydraulic test stand (Refer to Figure 3-11)

- Hose fittings for valve ports:
 Port PX 7/16 in., # 4 SAE
 Ports B1 and B2 3/4 in., #8 SAE
 Port T 1 1/16 in., #12 SAE

- Ohmmeter or continuity tester

NOTE: It is possible to check the pressures with the dual relay valve installed on the truck by using the brake treadle valve to modulate pilot pressure and monitoring brake apply pressure in the appropriate brake apply pressure lines.

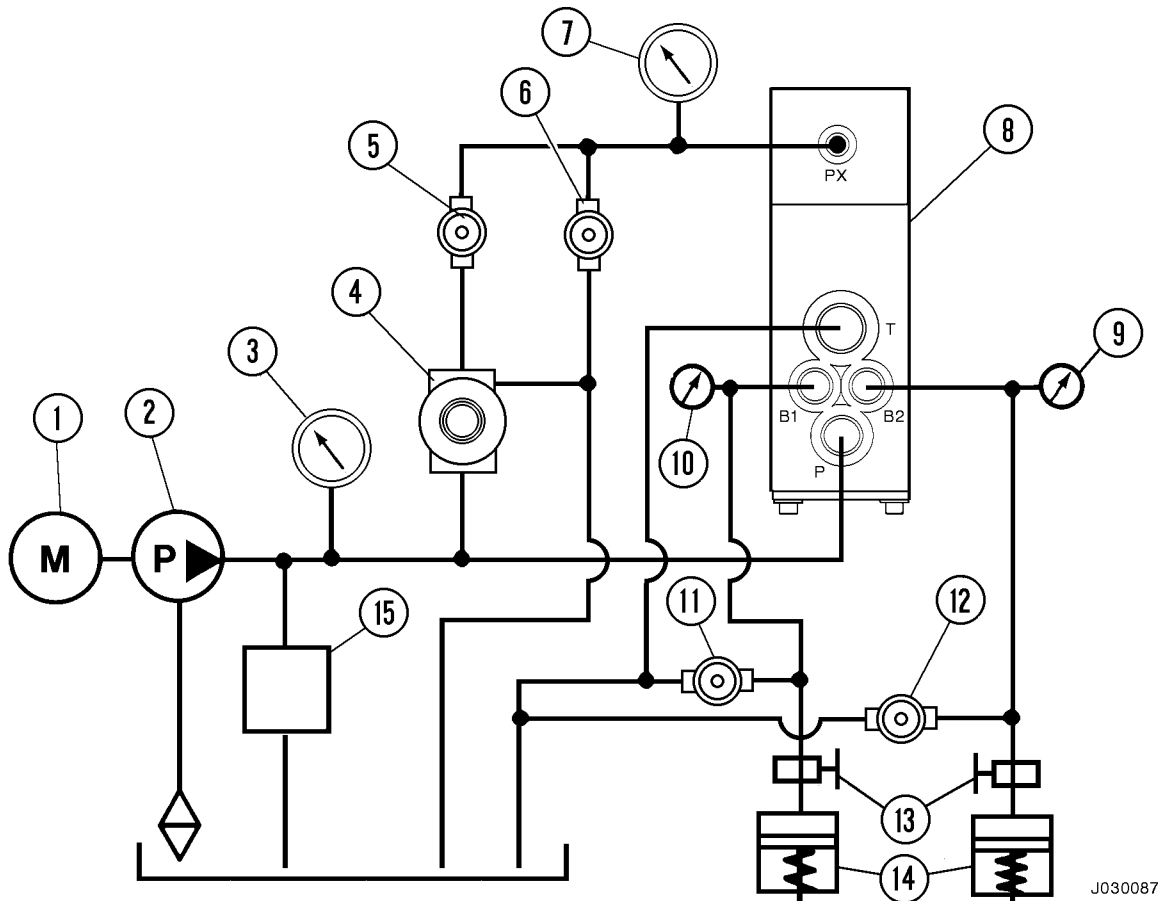

FIGURE 3-11. DUAL RELAY VALVE BENCH TEST SETUP

- | | | |
|---------------------------------------------|---------------------------------------------|--------------------------------------|
| 1. Motor | 6. Needle Valve
(Pressure Bleed to Tank) | 10. RH Brake Apply Pressure
Gauge |
| 2. Pump | 7. Pilot Pressure Gauge | 11. Needle Valve |
| 3. Main Pressure Gauge | 8. Dual Relay Valve | 12. Needle Valve |
| 4. Pressure Regulator
(Pilot Pressure) | 9. LH Brake Apply Pressure
Gauge | 13. Shutoff Valves |
| 5. Needle Valve
(Pilot Pressure Release) | | 14. Simulated Brake Volume |
| | | 15. Relief Valve |

RETARDER CONTROL LEVER (STEERING COLUMN-MOUNTED)

Due to frequent use and wear, retarder control lever (5, Figure 3-22) may occasionally require adjustment or repair.

Removal

Adjustment of the retarder control lever or replacement of the potentiometer requires removal of the assembly from the steering column.

1. Tilt the steering wheel downward and telescope the wheel toward the operator's seat. Remove the top cover from steering column assembly (4).
2. Remove capscrews (1, Figure 3-22), lockwashers (2) and bracket (3) from steering column (4).
3. Disconnect the wiring harness from harness connector (6) on the retarder control lever.
4. Remove retarder control lever (5).

Installation

1. Connect the wiring harness to harness connector (6) on the retarder control lever.
2. Place retarder control lever (5) into position on steering column assembly (4).
3. Install capscrews (1), lockwashers (2) and bracket (3). Tighten the capscrews to **4 N·m (36 in lb)**.
4. Place the cover on the top of the steering column and return the steering wheel to its original position.

Disassembly

1. Remove capscrews (7, Figure 3-23) and lockwashers (8) from housing (15).
2. Remove potentiometer (9).
3. Bend the tangs on washer (11) away from the slots in locknut (10).
4. If the retarder control lever is to be completely disassembled, loosen and remove locknut (10). Remove tang washer (11), spring (12), and washer (13).
5. Remove set screw (14).
6. Remove the lever and shaft assembly. If necessary, unscrew lever (17) from shaft (16) and handle (18).
7. Wash the mechanical parts in clean solvent and inspect for excessive wear, burrs, or scratches. Replace any defective parts.

Lever Adjustments

Rotational Friction Adjustment

The lever assembly should be adjusted so that the frictional forces will hold the lever firmly in the position that is selected by the operator. At the same time, the adjustment should not be so tight as to cause the operator to use undue force to move the lever.

Loosen or tighten locknut (10) to attain the proper frictional force of **0.25 - 0.35 N·m (2 - 3 in lb)** at the handle. The position of the lever should remain stationary without moving from its own weight or due to machine vibrations during truck operation.

When the desired adjustment is obtained, bend the tang on washer (11) into the slots on locknut (10).

Detent Adjustment

The detent that holds the lever in the OFF position can be adjusted. Loosen or tighten set screw (14) to adjust the detent. The breakout force of the detent must be between **2.00 - 2.25 N·m (17 - 20 in lb)**.

LOW ACCUMULATOR PRESSURE AND AUTO APPLY CHECK-OUT

29. Move both 20 685 kPa (3,000 psi) pressure gauges back to test ports "BF" (21, Figure 4-1) and "BR" (22) in the hydraulic brake cabinet.
30. Start the engine and allow the low brake accumulator pressure to stabilize at or above 18 615 kPa (2,700 psi).
31. Turn the key switch OFF to shut off the engine and allow 90 seconds for the steering system accumulators to bleed down.
32. Disable the steering pressure switch by unplugging the diode between circuits #33 and #33F on diode board DB1 in the auxiliary control cabinet or by disconnecting the wire harness at the steering pressure switch.
33. Turn the key switch ON, but do not start the engine. Wait for two minutes, then check the low accumulator pressure reading at low accumulator pressure (LAP1) test port (15).
 - If the pressure is below 14 480 kPa (2,100 psi), there is excessive leakage in the system. The source of the leakage must be identified and repaired.

** Record on data sheet.*
34. Very slowly open front brake accumulator bleed valve (9) a small amount while observing the decreasing pressure at low accumulator pressure (LAP1) test port (15).
 - The low brake pressure warning light and buzzer must activate when the pressure drops to $12\,755 \pm 517$ kPa ($1,850 \pm 75$ psi).

** Record on data sheet.*

 - When the low accumulator pressure reaches 11 375 kPa (1,650 psi), brake pressures "BF" and "BR" should begin to rise (auto apply).

** Record on data sheet.*
35. Close front brake accumulator bleed valve (9, Figure 4-1). Record the front and rear brake apply pressures after auto apply has occurred.

** Record on data sheet.*
36. Start the engine and allow the low brake accumulator pressure to stabilize at or above 18 615 kPa (2,700 psi).
37. Turn the key switch OFF to shut off the engine and allow 90 seconds for the steering system accumulators to bleed down.
38. Turn key switch ON, but do not start the engine.
39. Very slowly open rear brake accumulator bleed valve (7) a small amount while observing the decreasing pressure at low accumulator pressure (LAP1) test port (15).
 - Verify that the low accumulator pressure warning activation pressure and the auto apply set point are within 690 kPa (100 psi) of the pressures that were recorded previously for Step 33.
40. Close rear brake accumulator bleed valve (7). Record the front and rear brake apply pressures after auto apply has occurred.

** Record on data sheet.*
41. Reinstall the diode on diode board DB1 or reconnect the wire harness at the steering pressure switch.
42. Start the engine and allow the low brake accumulator pressure to stabilize at or above 18 615 kPa (2,700 psi).
43. Use the emergency shutdown switch on the center console to shut off the engine. Do not turn the key switch OFF. The steering accumulators must not be allowed to bleed down.
44. While observing the pressure gauges, make repeated, slow brake applications until auto apply comes on.
 - Auto apply must not occur before the sixth pedal application.
 - Auto apply must not occur until after the low accumulator pressure warning activates.

** Record on data sheet.*
45. Turn the key switch OFF and allow the steering accumulators to bleed down.
46. Open both accumulator bleed valves and bleed down the entire brake system. Close the valves after all pressure is released.
47. Remove all test equipment from the truck.

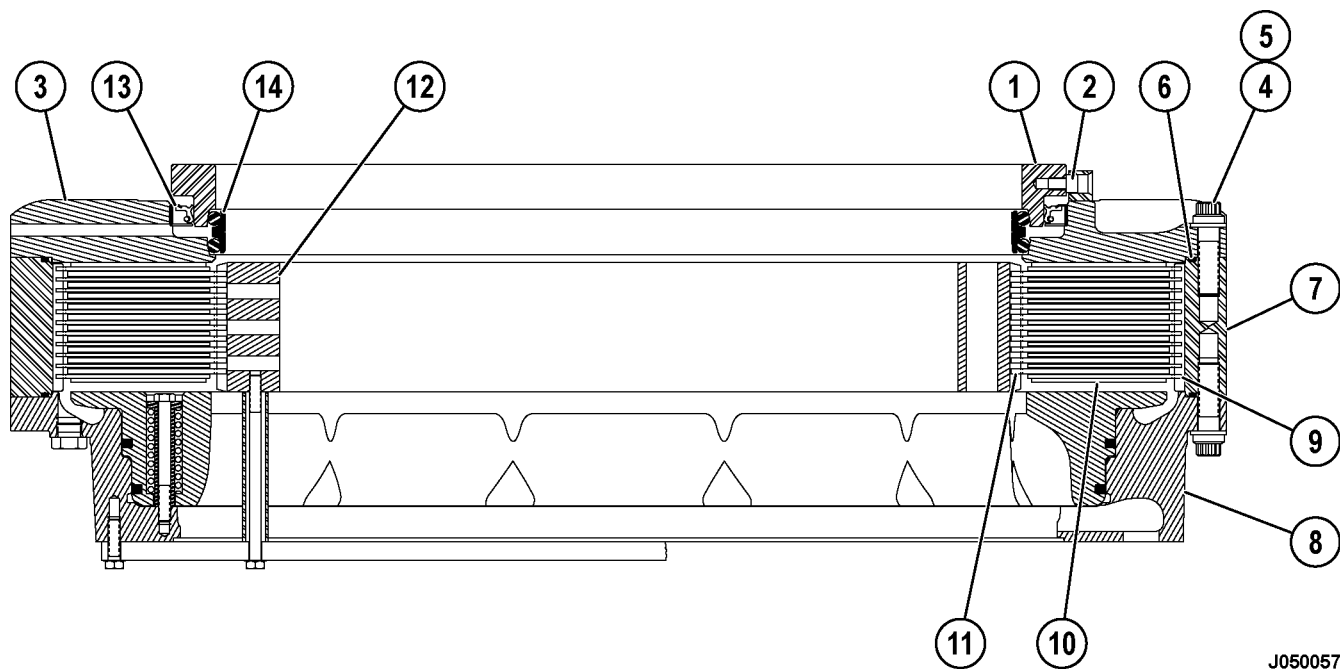

J050057

FIGURE 5-5. INITIAL DISASSEMBLY

- | | | |
|--------------------|--------------------|-------------------|
| 1. Seal Carrier | 6. O-Ring | 11. Friction Disc |
| 2. Capscrew | 7. Ring Gear | 12. Inner Gear |
| 3. Back Plate | 8. Piston Housing | 13. Oil Seal |
| 4. Capscrew | 9. Separator Plate | 14. Seal Assembly |
| 5. Hardened Washer | 10. Damper | |

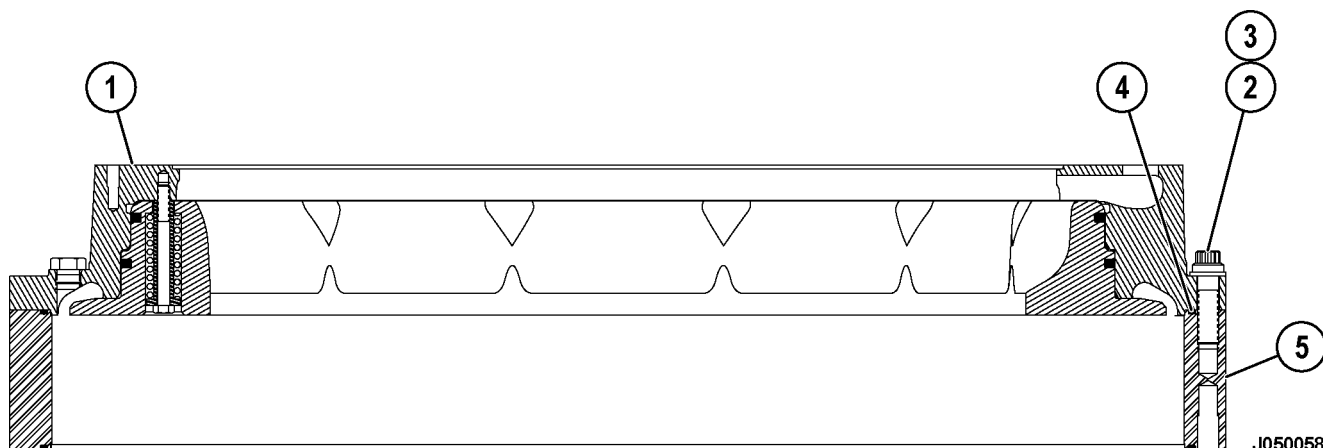

J050058

FIGURE 5-6. PISTON/HOUSING ASSEMBLY REMOVAL

- | | | |
|-------------------|--------------------|--------------|
| 1. Piston Housing | 3. Hardened Washer | 5. Ring Gear |
| 2. Capscrew | 4. O-Ring | |

WET DISC BRAKE BLEEDING PROCEDURE

NOTE: Rear wheel brakes must be bled before rear tire installation.

1. Make sure that the hydraulic brake supply (steering circuit) is operating properly.
2. If necessary, charge the brake system accumulators. Refer to Section J3, Brake Circuit Component Service.
3. Make sure that the bleed down valves on brake accumulator manifold are closed.
4. Check the hydraulic tank oil level and fill if necessary.
5. With the wheels securely blocked, start the engine and allow the accumulators to fill.
6. Slowly depress the brake pedal until the service brake is partially applied.

Rear Wheel Brakes:

7. Crack open the plug in brake apply pressure port (2, Figure 5-9) on the brake back plate. Close the plug after the oil runs clear of contaminants and free of bubbles. Repeat for the other rear wheel brake.

NOTE: The other brake cooling oil line has a single hex plug located next to it. This is the brake wear indicator port. DO NOT use this port for bleeding the brake.

Front Wheel Brakes:

NOTE: The front wheel brakes are equipped with a diagnostic coupler in brake apply pressure port (2, Figure 5-9) on the brake back plate. A hose with a mating fitting can be attached and used to direct the oil into a container during the bleeding process.

8. Attach a hose to the diagnostic coupler.
9. Slowly depress the brake pedal until the service brake is partially applied.
10. After the oil runs clear of contaminants and free of bubbles, remove the hose from the diagnostic coupler. Release the brake pedal.
11. Repeat Steps 8 through 10 for the other front wheel brake.
12. Shut off the engine and allow the steering accumulators to bleed down. Check the hydraulic tank oil level and fill if necessary.

**SECTION L
HYDRAULIC SYSTEM
INDEX**

HYDRAULIC SYSTEML2-1

HYDRAULIC SYSTEM COMPONENT REPAIRL3-1

STEERING CIRCUIT.....L4-1

STEERING CONTROL UNITL5-1

STEERING CIRCUIT COMPONENT REPAIRL6-1

HOIST CIRCUITL7-1

HOIST CIRCUIT COMPONENT REPAIRL8-1

HYDRAULIC SYSTEM FILTERSL9-1

HYDRAULIC CHECKOUT PROCEDURE.....L10-1

**SECTION L3
HYDRAULIC SYSTEM COMPONENT REPAIR
INDEX**

HYDRAULIC SYSTEM COMPONENT REPAIRL3-3

 HOIST PUMPL3-3

 RemovalL3-3

 InstallationL3-5

 InspectionL3-10

 AssemblyL3-10

 HOIST PUMP TROUBLESHOOTING GUIDEL3-15

 HYDRAULIC TANKL3-16

 RemovalL3-16

 InstallationL3-17

 HYDRAULIC TANK BREATHERSL3-17

 HYDRAULIC TANK STRAINERSL3-18

 RemovalL3-18

 Inspect and CleanL3-18

 InstallationL3-18

17. Lubricate O-ring (3, Figure 3-15) and install it in bearing plate (7). Lubricate O-rings (4) and install them over studs (12). Replace dowel (2) if removed. Install bearing plate (7).
18. Repeat Steps 9, 10 and 11 for installation of the steel rings, backup ring, O-ring, retainer, isolation plate and pressure plate.

19. Lubricate the inside diameter of bearings (26). Install O-rings (8) and (9) and dowel (25) if removed. Install gear plate (10). Make sure that the relief in the gear plate is toward bearing plate (7).

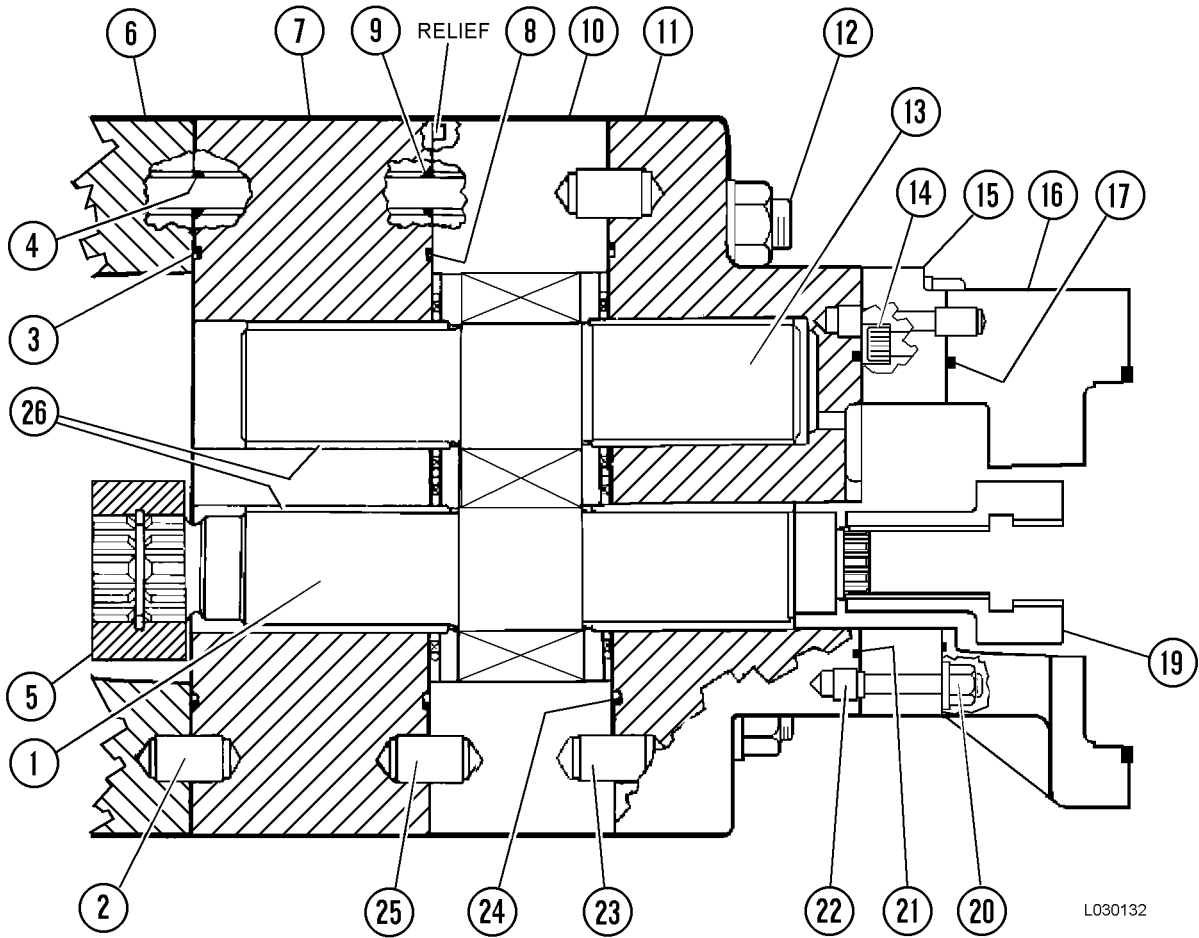

L030132

FIGURE 3-15. HOIST PUMP REASSEMBLY

- | | | | |
|----------------------|---------------------|----------------------|--------------|
| 1. Drive Gear (Rear) | 8. O-ring | 15. Bearing Plate | 22. Dowel |
| 2. Dowel | 9. O-ring | 16. Transition Plate | 23. Dowel |
| 3. O-ring | 10. Gear Plate | 17. O-ring | 24. O-ring |
| 4. O-ring | 11. Connector Plate | 18. (Not Used) | 25. Dowel |
| 5. Coupling | 12. Stud | 19. Coupling | 26. Bearings |
| 6. Connector Plate | 13. Idler Gear | 20. Nut | |
| 7. Bearing Plate | 14. Capscrew | 21. O-ring | |

Relief Valves

Relief valve (4, Figure 4-4), located in the bleeddown manifold, limits the hydraulic supply pressure to the steering and brake circuits to 27 500 kPa (4,000 psi).

Relief valve (3) provides maximum pressure protection of 4 100 kPa (600 psi) for the oil returning to the hydraulic tank.

Hoist Up Limit Solenoid

Hoist up limit solenoid (6) is a 3-way valve that is activated by the hoist limit switch when the hoist cylinders approach the maximum extension limit. When activated, the solenoid will close the power up pilot line to the hoist valve from the hoist pilot valve mounted in the hydraulic cabinet.

Pilot operated check valve (30, Figure 4-5) is opened by power down pilot pressure line (19) to allow oil in the raise port to bypass hoist up limit solenoid (24) for the initial power down operation while the solenoid is activated by the hoist limit switch.

Refer to Section D3, 24VDC Electrical System Components, for more information about the hoist limit switches.

Steering Accumulators

The two steering accumulators (3, Figure 4-1) are bladder type accumulators with a capacity of 62 liters (16.5 gallons) each. The accumulators are charged to 9 700 kPa (1,400 psi) with pure dry nitrogen using the charging valve located on the top end.

Oil entering the accumulators compresses the nitrogen in the bladder. The nitrogen pressure increases directly with steering circuit pressure. When steering circuit pressure reaches 20 900 kPa (3,025 psi), the unloader valve will unload the pump. The accumulators will contain a quantity of oil, under pressure and held by check valves in the bleeddown manifold, that will be available for steering the truck. When system pressure drops to 19 000 kPa (2,750 psi), the pump output will again increase to refill the accumulators and increase the steering system pressure. The accumulators also provide oil for a limited period of time to be used in case the pump becomes inoperative.

Low Precharge Warning Switch

Pressure switches, located in the top of each accumulator, monitor the nitrogen pressure and are used to activate the accumulator precharge warning light if the nitrogen pressure drops below 7 600 kPa (1,100 psi).

The switches monitor nitrogen pressure when the key switch is turned ON before the engine is started. If nitrogen pressure is too low, the warning lamp turns on. A latching circuit prevents the warning lamp from turning off when the engine is started and steering system pressure compresses the nitrogen remaining in the accumulator.



Do not operate the truck with less than 7 600 kPa (1,100 psi) of nitrogen precharge in the accumulator. Low nitrogen pressure may not provide an adequate supply of steering system oil in some emergency conditions. If the low precharge warning light remains on, check the accumulator precharge pressure and recharge if necessary.

High Pressure Filter

High pressure filter (9, Figure 4-1) filters oil for the steering and brake circuits.

If the filter element becomes restricted, a warning indicator is activated at 241 kPa (35 psi) differential, and oil will bypass the element at 345 kPa (50 psi) differential.

Refer to Section L9 for further information regarding hydraulic system filters.

Quick Disconnect Ports

Ports on the bleeddown manifold allow service personnel to connect an external hydraulic supply to allow operation of the truck steering and service brake systems if the steering/brake pump or engine is not operational.

The external supply is connected to port (24, Figure 4-3) and the return is connected to port (25). This feature should only be used for an emergency to allow operation of the truck to return to the shop for service or to move the truck out of haul road traffic.

1. Plug
2. O-ring
3. Spring
4. Back-Up Ring
5. O-Ring
6. Back-Up Ring
7. O-Ring
8. O-Ring
9. O-Ring
10. Back-Up Ring
11. Spring
12. Control Piston Sleeve
13. Spring
14. Piston
15. Pin
16. Control Piston Stop Pin
17. Shoe Retainer
18. Pin
19. Retainer Ring
20. Washer
21. Saddle Bearing
22. Roll Pin
23. Link
24. O-Ring
25. Stroke Adjuster
26. Retainer Ring
27. Pin
28. Swashblock
29. Dowel Pin
30. Saddle
31. Roll Pin
32. Retainer Ring
33. Bearing
34. Shaft Retainer Ring
35. Shaft
36. Seal Retainer
37. Pump Housing
38. Shaft Seal
39. O-Ring
40. Fulcrum Ball
41. Cylinder Bearing
42. O-Ring
43. Elbow Fitting
44. Piston/Shoe Assembly
45. Cylinder Barrel
46. Gasket
47. Bearing
48. Valve Plate
49. Capscrew
50. O-Ring
51. Cover
52. Seal
53. Cap

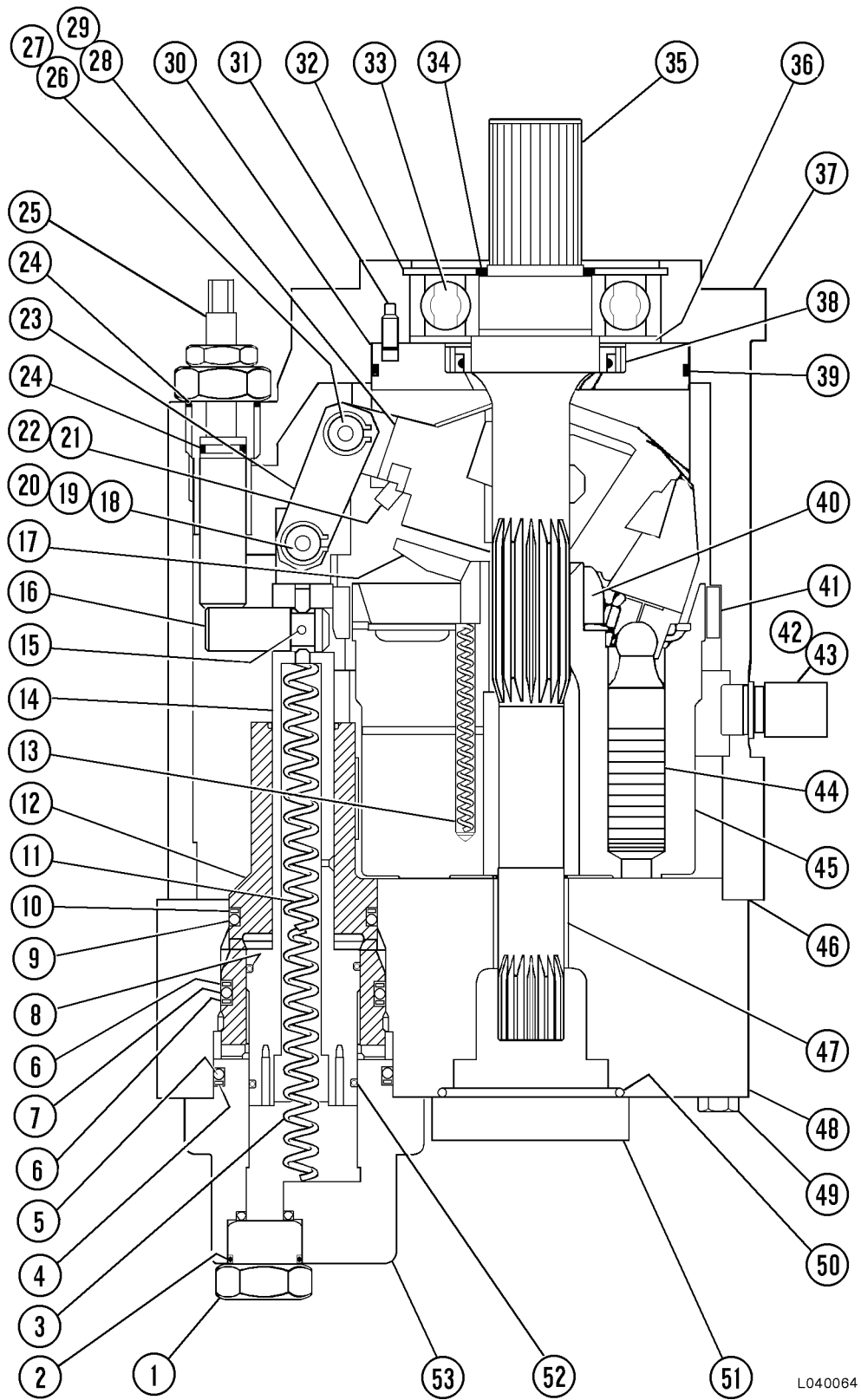

FIGURE 4-11. STEERING PUMP

L040064

10. Install the check ball in the hole shown in Figure 5-12. Install and lightly tighten the threaded bushing.
11. Lubricate O-ring (3) with Vaseline and install it in the housing groove.

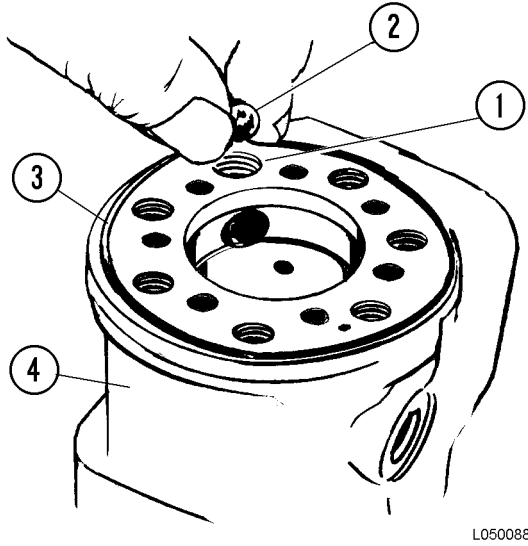

FIGURE 5-12. CHECK BALL INSTALLATION

- | | |
|--------------------|------------|
| 1. Check Ball Hole | 3. O-ring |
| 2. Check Ball | 4. Housing |

12. Install distribution plate (15, Figure 5-7) so that the plate holes match the corresponding holes in the housing.
13. Guide cardan shaft (11) down into the bore with the slot in the cardan shaft aligned with cross pin (9).
14. Position the inner gear wheel onto the cardan shaft. It may be necessary to rotate the gear slightly to find the matching splines on the cardan shaft. Splines are machined to ensure proper alignment of the cardan shaft and inner gear wheel.
15. Lubricate O-rings (17) and (18) on both sides of the outer gear wheel with Vaseline and install them.
16. Align the outer gear wheel bolt holes with the tapped holes in the housing and the match marks.
17. Align cover (19), using the match marks as a reference. Install capscrews (23) and washers (20).
18. Install capscrew with pin (22) into the proper hole.
19. Install the end cover. Install and tighten the capscrews with washers hand-tight in a criss-cross pattern.

Installation

1. Install a new O-ring on the pump mounting flange.
2. Ensure that the steering pump splined coupler is in place inside the hoist pump before steering pump installation.

WARNING

The steering pump weighs approximately 113 kg (250 lb). Use a suitable lifting device capable of handling the load safely.

3. Move steering/brake pump (1, Figure 50-8) into position. Engage the steering/brake pump shaft with the hoist pump spline coupler.
4. Install two spacers (6) and capscrews (5). Do not tighten the capscrews at this time.
5. Align the capscrew holes and install four pump mounting capscrews (8). Tighten the capscrews to the standard torque. Now tighten capscrews (5) to the standard torque.
6. If the hydraulic tank is full of oil, install vacuum pump kit (XB0887) on the hydraulic tank to prevent the loss of oil when reconnecting hydraulic lines.
7. Remove all plugs from the hoses and ports. Install hoses (2), (3) and (4) on the steering/brake pump with new O-rings. Tighten the capscrews securely. Do not connect case drain hose (7) at this time (see Step 8).
8. Remove the case drain fitting from the top of the pump housing. Add clean C-4 hydraulic oil to the pump through the opening until the pump housing is full. This may require 2 to 3 liters (2 to 3 qt.) of oil.
9. Install the case drain fitting and tighten it to the standard torque. Connect case drain hose (7) to the fitting.
10. If used, turn off vacuum pump kit (XB0887) and remove the vacuum pump from the hydraulic tank.
11. Replace the hydraulic filter elements. Refer to Section L9, Hydraulic System Filters.

IMPORTANT

Use only Komatsu filter elements, or elements that meet the Komatsu hydraulic filtration specification of Beta 12 = 200.

12. With the body down and the engine stopped, fill the hydraulic tank with clean C-4 hydraulic oil (as specified on the truck Lubrication Chart) to the upper sight glass level.
13. With suction line shutoff valve open, loosen the suction (inlet) hose capscrews at the pump to bleed any trapped air. Retighten the capscrews to the standard torque.

IMPORTANT

If trapped air is not bled from steering pump, possible pump damage and no output may result.

14. If required, top off the oil in the hydraulic tank to the level of the upper sight glass.
15. In the hydraulic brake cabinet, open both brake accumulator needle valves completely to allow the steering pump to start under a reduced load.
16. Move the hoist control lever to the FLOAT position.
17. Start the truck engine and operate at low idle for two minutes.

WARNING

Do not allow the engine to run with the needle valves in the open position for longer than this recommendation. Excessive hydraulic system heating will occur.

DO NOT start any hydraulic pump for the first time after an oil change or pump replacement with the truck dump body raised. The oil level in the hydraulic tank may be below the level of the pump(s), causing extreme pump wear during this initial pump startup.

18. Turn off the engine. Fully close both brake accumulator needle valves.
19. Verify that the oil level in the hydraulic tank is at the upper sight glass when the engine is off and the body is resting on the frame. If the hydraulic oil level is not at the upper sight glass, follow the instructions for filling/adding oil in Section L3, Hydraulic System Component Repair.
20. Start the engine and check for proper pump operation. If necessary, refer to Steering Circuit Checkout Procedure in Section L10, or the Troubleshooting Chart at the end of this section.

Disassembly

1. After the accumulator has been removed from the equipment, the accumulator body should be secured in a vise, preferably a chain vise. If a standard jaw vise is used, brass inserts should be used to protect the hydraulic port assembly from damage. Clamp on wrench flats only when using a jaw vise to prevent the accumulator from turning.
2. Remove bleed plug (12, Figure 6-17) on the hydraulic port assembly. Use a spanner wrench to remove locking ring (10) from the hydraulic port assembly. Use an adjustable wrench on the flats located on the port assembly to prevent the port assembly from rotating.
3. Remove spacer (9), then push the hydraulic port assembly into the shell.
4. Insert your hand into the accumulator shell and remove O-ring backup (8), O-ring (7), and metal backup washer (6). Separate anti-extrusion ring (3) from the hydraulic port. Fold the anti-extrusion ring and remove it from the shell (Figure 6-15).
5. Remove the hydraulic port from the accumulator shell.
6. To prevent the bladder valve stem from twisting, secure it with an appropriate wrench applied to the valve stem flats. Remove gas valve manifold (14, Figure 6-17). Then remove nut (5) while still holding the bladder valve stem.
7. Fold the bladder and pull it out of the accumulator shell. A slight twisting motion while pulling on the bladder reduces the effort required (Figure 6-16). If the bladder is slippery, hold it with a cloth.

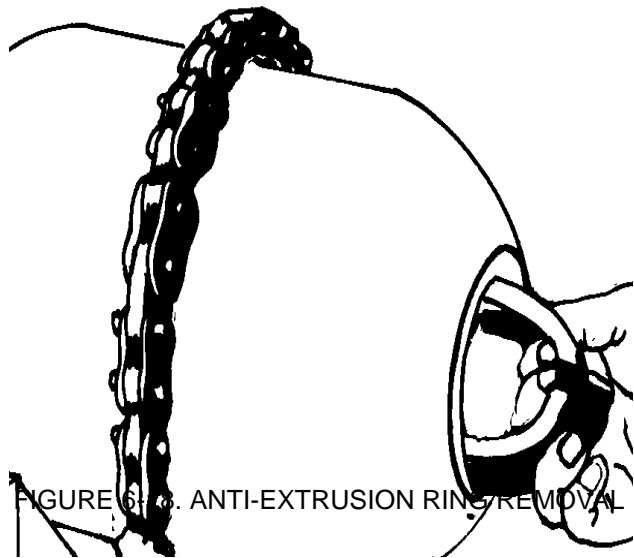

FIGURE 6-15. ANTI-EXTRUSION RING REMOVAL

Cleaning and Inspection

1. Clean all metal parts with a cleaning agent.
2. All seals and soft parts should be wiped clean.
3. Inflate the bladder to normal size. Wash the bladder with a soap solution. If the bladder causes bubbles in the soap solution, discard the bladder. After testing, deflate the bladder immediately.
4. Inspect the hydraulic port assembly for damage. Check the poppet plunger to see that it spins freely and functions properly.
5. Check the anti-extrusion ring and soft seals for damage and wear. Replace all worn or damaged seals with original equipment seals.
6. After the shell has been cleaned with a cleaning agent, check the inside and outside of the shell. Special attention should be given to the area where the gas valve and hydraulic assembly pass through the shell. Any nicks or damage in this area could destroy the accumulator bladder or damage new seals. If this area is pitted, consult your Komatsu Service Manager.

▲ DANGER

DO NOT repair the housing by welding, machining or plating to salvage a worn area. These procedures may weaken the housing and result in serious injury to personnel when pressurized.

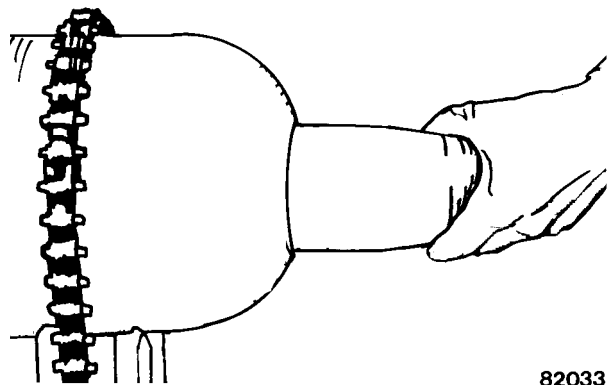

82033

FIGURE 6-19. BLADDER REMOVAL

SECTION L7 HOIST CIRCUIT INDEX

HOIST CIRCUIT	L7-3
BASIC OPERATION	L7-3
COMPONENT DESCRIPTION	L7-4
Hydraulic Tank	L7-4
Hydraulic Pump	L7-4
High Pressure Filters	L7-4
Hoist Valve	L7-4
Inlet Sections	L7-4
Work Ports (Rear) Spool Section	L7-5
Tank Ports (Front) Spool Section	L7-5
Hoist Pilot Valve	L7-5
Bleeddown Manifold	L7-6
Hoist Up Limit Solenoid	L7-6
Pilot Operated Check Valve	L7-6
Overcenter Manifold	L7-6
HOIST CIRCUIT OPERATION	L7-7
Float Position Of Pilot Valve With Truck Body On Frame	L7-8
Power Up Operation	L7-10
Hold Operation	L7-12
Power Down Operation	L7-14
Float Operation	L7-16

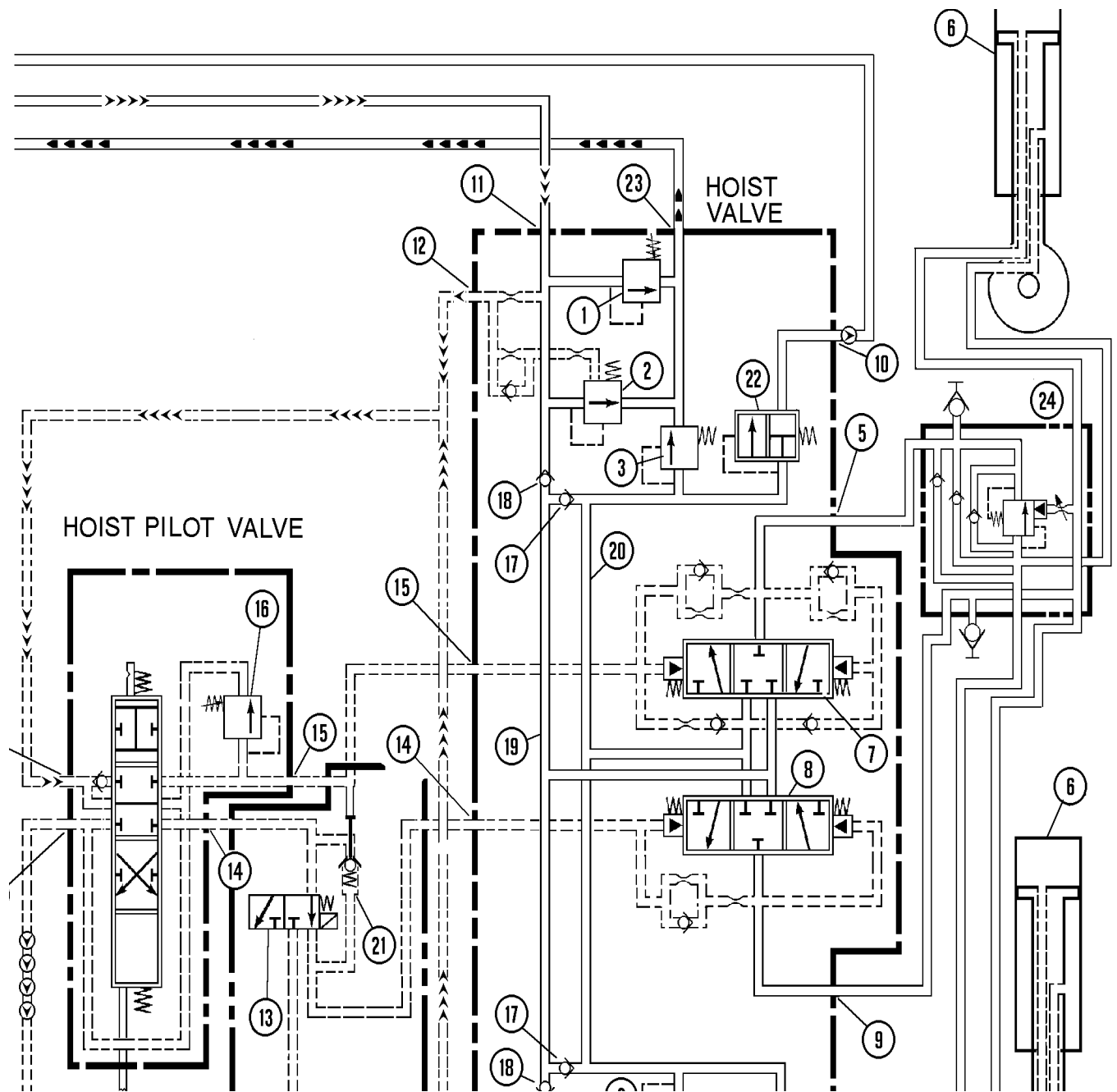

FIGURE 7-7. HOLD POSITION

- | | | |
|-------------------------------------------|-----------------------------------------|-----------------------------------------|
| 1. Hoist Relief Valve (2,500 psi) | 9. Head End Work Port | 17. Anti-void Check Valve |
| 2. Flow Control Valve | 10. Tank Return Port | 18. Load Check Valve |
| 3. Secondary Low Pressure Valve (250 psi) | 11. Supply Port | 19. High Pressure Passage |
| 4. Snubber Valve | 12. Pilot Supply Port | 20. Low Pressure Passage |
| 5. Rod End Work Port | 13. Hoist Limit Solenoid | 21. Pilot Operated Check Valve |
| 6. Hoist Cylinders | 14. Raise Pilot Port | 22. Primary Low Pressure Valve (26 psi) |
| 7. Rod End Spool | 15. Down Pilot Port | 23. Brake Cooling Circuit Port |
| 8. Head End Spool | 16. Power Down Relief Valve (1,500 psi) | 24. Overcenter Manifold |

REAR SPOOL SECTION (Work Ports)

Disassembly

NOTE: It is not necessary to remove inlet sections (1) or (4, Figure 8-2) to accomplish disassembly of spool section (2) or (3).

1. Match mark or identify each part when removed in respect to its location or respect to its mating bore to aid reassembly.
2. Remove capscrews and lift spool section cover (1, Figure 8-9) from the housing.
3. Remove poppet (1, Figure 8-7) from spool cover. Remove and discard O-ring (3).

NOTE: The poppet (1) contains a small steel ball. Do not misplace.

4. Remove and discard O-rings (4) and (5, Figure 8-8).
5. Remove restrictor poppet (1). Remove and discard O-ring (2) and backup ring (3), if used. Note the position of the restrictor when removed to ensure correct reassembly.
6. Remove spool assembly (20, Figure 8-9). Note the color of the lower spring (blue) to ensure proper location during reassembly. Also note the "V" groove on the top end of the spool.

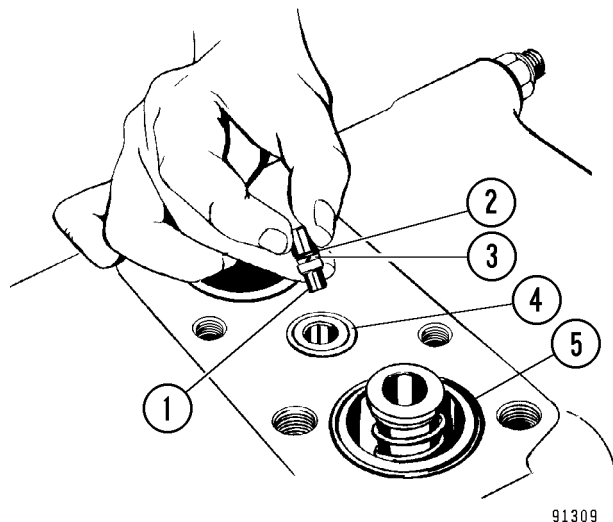

FIGURE 8-8. RESTRICTOR POPPET REMOVAL

- | | |
|----------------------|-----------|
| 1. Restrictor Poppet | 4. O-Ring |
| 2. O-Ring * | 5. O-Ring |
| 3. Backup Ring * | |

***Note: Items 2 and 3 not used on all valves.**

7. Remove plug (3) from the end of the spool. Remove spring seat (2) and spring (11). Remove poppet (21) and spool end (15).

NOTE: Pay special attention to poppets (12), (21) and (22, Figure 8-9) during removal to ensure proper location during reassembly. Poppets may be identified with a colored dot (red, green or white). If the poppets are not color coded, use the table below and the specified drill bit to measure the orifice diameter for proper identification.

POPPET COLOR	ORIFICE DIAMETER	DRILL SIZE
Red	3.556 mm (.140 in.)	#28
Green	2.362 mm (.093 in.)	#42
White	1.600 mm (.063 in.)	#52

8. Repeat Step 7 to disassemble the opposite end of spool (20). Note that there is no plug or restrictor poppet in the opposite end and the spring is blue.
9. Remove spool assembly (14). At the top end of the spool, remove plug (3). Remove spring seat (2) and spring (11). Remove poppet (12) and spool end (15).
10. At the opposite end, remove plug (3), spring seat (2) and spring (16). Remove restrictor poppet (22) and spool end (15).
11. Remove cover (19) and O-rings (4), (5) and (10). Remove poppet (18).

Cleaning and Inspection

1. Discard all O-rings and backup rings. Clean all parts in solvent and blow dry with compressed air.
2. Inspect all springs for breaks and distortion. Inspect the poppet seating surfaces for nicks and excessive wear. All seats must be sharp and free of nicks.
3. Inspect all bores and surfaces of sliding parts for nicks, scores and excessive wear.
4. Inspect all poppets in their respective bore for proper fit. Poppets should move freely through a complete revolution without binding.

Cleaning and Inspection

NOTE: Use only fresh cleaning solvent, a lint-free wiping cloth and dry, filtered compressed air when cleaning and handling hydraulic cylinder parts. Immediately after cleaning and inspection, coat all surfaces and parts with clean Type C-4 hydraulic oil.

1. Thoroughly clean and dry all parts.
2. Inspect all parts for damage and excessive wear.
3. If the cylinder bores or plated surfaces are excessively worn or grooved, the parts must be replaced or, if possible, replated and machined to original specifications.
4. Check the tightness of quill assembly (2, Figure 8-20) if it has not previously been tack welded.
 - a. Check the tightness of the quill by using special tool SS1143 (Figure 8-20) and applying a tightening torque of **1 356 N·m (1,000 ft lb)**.
 - b. If the quill moves, remove the quill from cap assembly (1). Clean the threads in the cap and on the quill.
 - c. To install the quill, perform the Quill Installation procedure on the next page.
5. When a cylinder assembly is dismantled, check capscrews (7, Figure 8-19) carefully for distress. Replace the capscrews if in doubt.

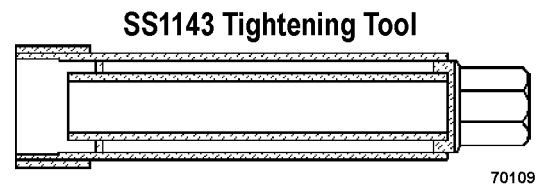
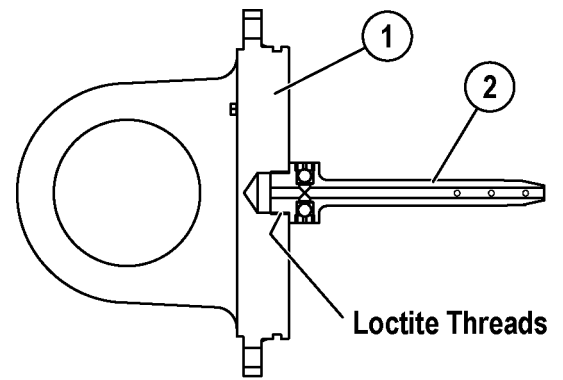

FIGURE 8-20. QUILL INSTALLATION

1. Cap Assembly 2. Quill Assembly

NOTE: SS1143 Tightening Tool can be made locally. Request the following drawings from your Area or Regional Service Manager:

SS1143 Tightening Tool - Assembly Drawing

- SS1144 - Square Tube
(3.50" x 3.50" x 0.19" wall x 2.0" long)
- SS1145 - Plate
(2.50" x 2.50" x 0.25" thick)
- SS1146 - Square Tube
(3.00" x 3.00" x 0.25" wall x 15.50" long)
- SS1147 - Tube, Brass
(1.75" O.D. x 1.50" I.D. x 13.50" long)
- SS1148 - Square Cut
(2.50" x 2.50" x 0.75" thick)
- SS1149 - Hex Drive
(1.75" Hex stock x 2.50" long)

All materials are 1020 Steel except SS1147.

PRESSURE SWITCH TESTER

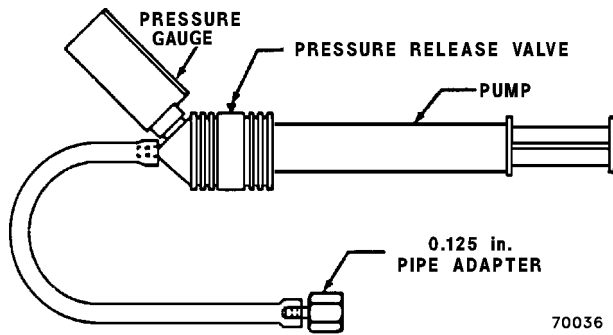

The indicator switch tester may be ordered from:

Kent-Moore Heavy Duty Division
 Sealed Power Corp.
 29784 Little Mack
 Roseville, MI 40866-9984

Phone: (313) 774-9500

70036

FIGURE 9-3. INDICATOR SWITCH TESTER
 Kent-Moore Part No. J-33884-4

TEST BLOCK for DIFFERENTIAL PRESSURE SWITCH

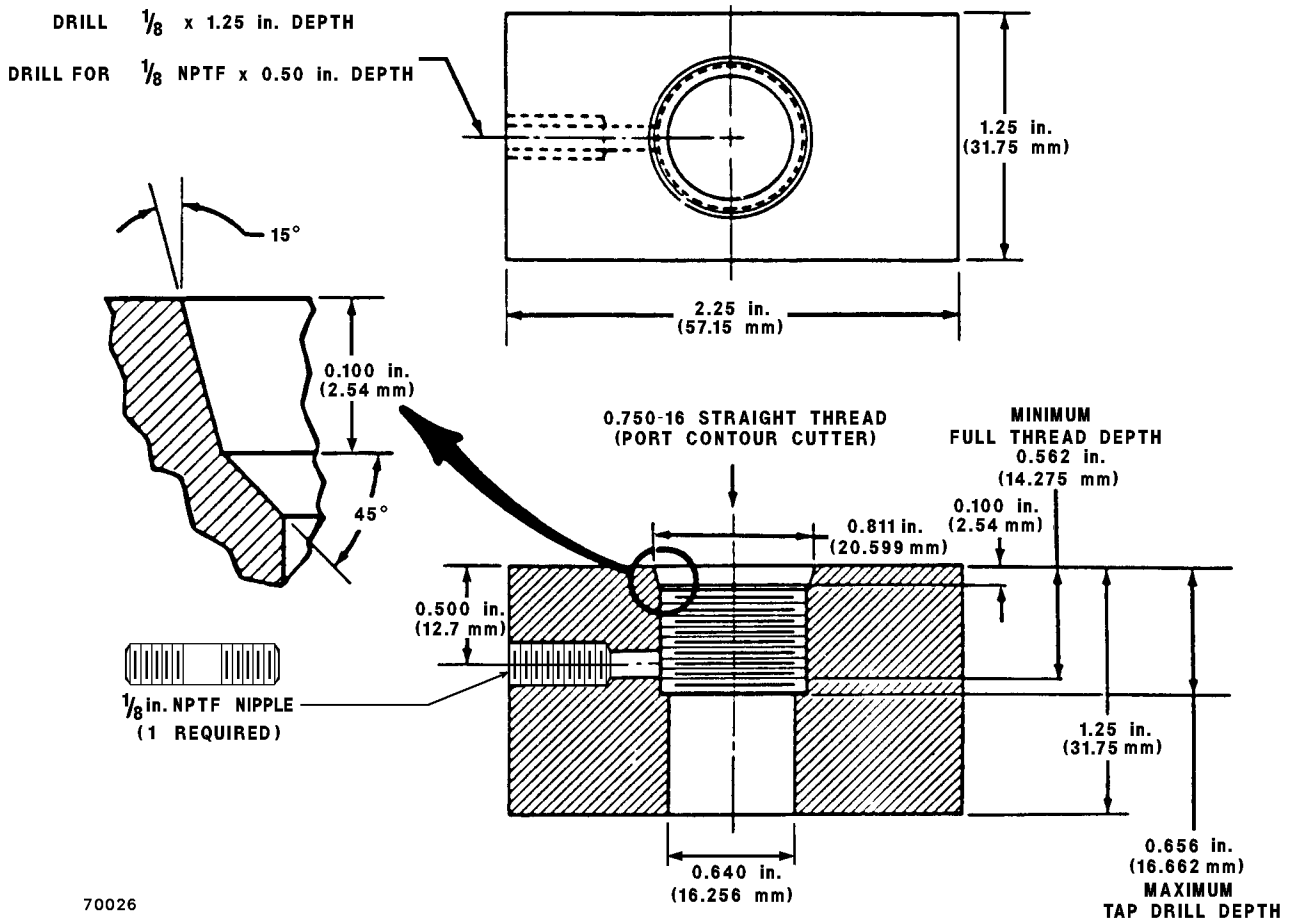

FIGURE 9-4. INDICATOR SWITCH PRESSURE TEST BLOCK

Equipment Requirements

The following equipment will be necessary to properly check-out the hydraulic steering circuit:

- Hydraulic schematic (see Section R)
- Two 35 000 kPa (5,000 psi) calibrated pressure gauges and hoses
- A graduated container marked to measure liquid volume in cubic inches or milliliters

Pump Pressure Control Adjustments

With the brake system functioning properly and the parking brake on, proceed as follows:

1. Place the directional control lever in PARK. Place the rest switch in the ON position and the GF cutout switch in the CUTOUT position. Turn the key switch OFF and wait 90 seconds for the steering accumulators to completely bleed down before opening any hydraulic circuits.
2. Check the hydraulic oil level in the tank and add oil if required. Ensure that the suction line shutoff valves are open.

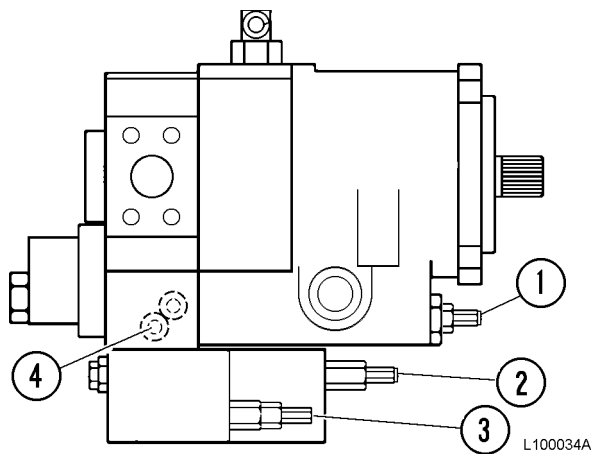
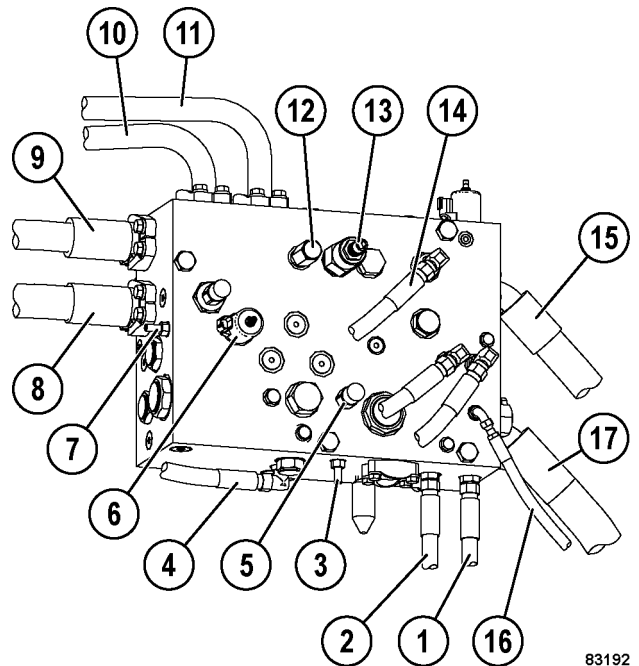

FIGURE 10-9. STEERING/BRAKE PUMP ADJUSTMENTS

1. Pump Stroke Adjustment Screw
2. Unloader Valve Adjustment Screw
3. Compensator Adjustment Screw
4. GPA Port



83192

FIGURE 10-10. BLEEDDOWN MANIFOLD

1. To Hoist Valve, Power Up
2. To Hoist Valve, Power Down
3. Pressure Test Port (TP2)
4. Brake System Supply Line
5. Steering System Pressure Switch
6. Steering Accumulator Bleeddown Solenoid
7. Pressure Test Port (TP3)
8. Supply to Flow Amplifier
9. Return from Flow Amplifier
10. To Front Steering Accumulator
11. To Rear Steering Accumulator
12. Relief Valve, 600 psi (4.1 MPa)
13. Relief Valve, 4000 psi (28.0 MPa)
14. Hoist Pilot Valve Return Line
15. Tank Return Line
16. Feedback Pressure to Unloader valve
17. Supply from Pump

3. Install an accurate 35 000 kPa (5,000 psi) pressure gauge at steering pressure "GPA" test port (4, Figure 10-9) located on the suction side of the pump. Install a second 35 000 kPa (5,000 psi) gauge in bleeddown manifold test port "TP2" (3, Figure 10-10).
4. Turn unloader valve adjustment screw (2, Figure 10-9) clockwise until it bottoms out.
5. Back out compensator adjustment screw (3) by turning it counterclockwise.

**SECTION M
OPTIONS AND SPECIAL TOOLS
INDEX**

HOT START SYSTEM..... M7-1

SPECIAL TOOLS M8-1

RADIATOR SHUTTERS M19-1

PAYLOAD METER III..... M20-1

RESERVE ENGINE OIL SYSTEM M31-1

Part Number	Description	Use
PC2061	Belt Tension Tester	A/C Belt Tension Check

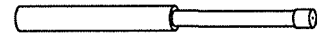

Part Number	Description	Use
EL8868	V-Belt Alignment Tool	A/C Belt Alignment

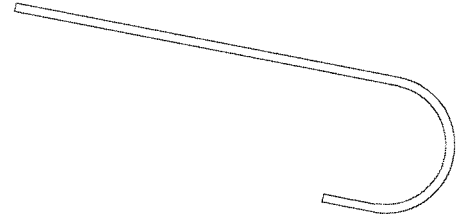

SECTION M20
PAYLOAD METER III™
INDEX

OPERATION SECTION	M20-5
INTRODUCTION	M20-5
Data Summary	M20-5
Data Gathering	M20-5
COMPONENT DESCRIPTION	M20-6
System Diagram	M20-6
Suspension Pressure Sensors	M20-6
Inclinometer	M20-6
Operator Display	M20-6
Operator Switch	M20-7
Speed Input	M20-7
Body-Up Switch	M20-7
Brake Lock Switch	M20-7
Payload Meter	M20-7
Communications Ports	M20-7
Key Switch Input	M20-8
Payload Meter Power	M20-8
Load Lights	M20-8
Wiring and Termination	M20-9
TCI Outputs	M20-9
OPERATOR'S DISPLAY AND SWITCH	M20-10
Reading the Speedometer	M20-10
Reading the Load Display	M20-10
Using the Operator ID	M20-10
Using the Load and Ton Counter	M20-10
Total Ton Counter	M20-10
Total Load Counter	M20-11
Clearing the Counters	M20-11
Viewing Live Sensor Data	M20-11
Other Display Messages	M20-11

Load Calculation

The final load calculation is different from the last swingload calculation. The accuracy of the swingload calculation depends on loading conditions and the position of the truck during loading. The last swingload calculation is not the value recorded in memory as the final load. The final load is determined by a series of calculations made while the truck is traveling to the dump site.

Carry Back

Carry back is calculated as the difference between the current truck tare and the clean truck tare. The clean truck tare is calculated using the PC software. When the suspensions are serviced or changes are made that may affect the sprung weight of the truck, a new clean truck tare should be calculated.

Measurement Accuracy

Payload measurements are typically repeatable within 1%. Accuracy for a particular scale test depends on specific combinations of pressure sensors and payload meters as well as the specifics of each scale test. Comparisons from different scale tests are often made without considering the differences introduced by the specific installation and operation of the scales for each test. In addition, each pressure sensor and payload meter introduces its own non-linearity. Each truck becomes an individual combination of sensors and payload meter. Errors from these sources can introduce up to a $\pm 7\%$ bias in the payload meter calculations for a specific scale test, for an individual truck.

Because the PLMIII calculates a new empty tare for each payload, a detailed scale test must weigh the trucks empty and loaded for each haul cycle. Using a simple average of 2 or 3 empty truck weights as an empty tare for the entire scale test will introduce significant error when comparing scale weights to PLMIII weights.

SOURCES FOR PAYLOAD ERROR

Payload Error

The number one source of error in payload calculation is improperly serviced suspensions. The payload meter calculates payload by measuring differences in the sprung weight of the truck when it is empty and when it is loaded. The sprung weight is the weight of the truck supported by the suspensions. The only method for determining sprung weight is by measuring the pressure of the nitrogen gas in the suspensions. If the suspensions are not properly maintained, the payload meter cannot determine an accurate value for payload. The two critical factors are proper oil height and proper nitrogen charge.

If the suspensions are overcharged, the payload meter will not be able to determine the empty sprung weight of the truck. The suspension cylinder must be able to travel up and down as the truck drives empty. The pressure in an overcharged suspension can push the suspension rod to full extension. In this case, the pressure inside the cylinder does not accurately represent the force necessary to support that portion of the truck.

If the suspensions are undercharged, the payload meter will not be able to determine the loaded sprung weight of the truck. The suspension cylinder must be able to travel up and down as the truck drives loaded. If the pressure in an undercharged suspension cannot support the load, the suspension will collapse and make metal-to-metal contact. In this case, the pressure inside the cylinder does not accurately represent the force necessary to support that portion of the truck.

Low oil height can also introduce errors by not correctly supporting a loaded truck. This is why the correct oil height and nitrogen charge are the most critical factors in the measurement of payload. If the suspensions are not properly maintained, accurate payload measurement is not possible. In addition, suspension maintenance is very important to the life of the truck.

DATA ANALYSIS

PAYLOAD SUMMARY FORM

Date: Sorts the data within a date range. eg. "Dec 1, 2000 through Dec 31, 2000"

Truck Number: Sorts the data by the truck unit number, eg. "374"

Payload Data Summary: Summary statistical analysis of the payloads from the selected query.

Output Options: Use to create reports, graphs and expert data from the selected query.

Time: Sorts the data within a time for each day within the data range. "8:00 AM to 5:00PM"

Truck Type: Sorts the data by the truck type, eg. "930E" or "830E"

Query Database & Display: Sorts the data by the selected query options (unit, type, date, time) and displays the results.

Cycle Summary: Cycle time summary from the selected query.

Haul Cycle Records: Summary view of the haul cycle records from the selected query. Double Click to view the details for individual haul cycle records. Haul cycles in red area are not included in the summary statistics..

Truck Number	Date	Time	Payload	# Swings	Total Time
351	07/10/2000	8:22:40 AM	323.8	5	7:09
351	07/10/2000	8:36:12 AM	323.8	5	5:23
351	07/10/2000	8:41:35 AM	323.8	5	5:24
351	07/10/2000	8:46:58 AM	321.5	1	30:11
351	07/10/2000	9:17:06 AM	321.9	0	0:32
351	07/10/2000	9:17:37 AM	318.0	0	0:32

The data analysis tools allow the user to monitor the performance of the payload systems across the fleet. Analysis begins when the "View Payload Data" button is pressed. This starts an "all trucks, all dates, all times" query of the database and displays the results in the Payload Summary Form.

The user can change the query by changing the dates, times, or trucks to include in the query for display.

Haul cycles in the data grid box at the bottom can be double-clicked to display the detailed results of that haul.

Creating a Query

The program defaults to show all trucks, all types, all dates and all times for the initial query. The display can be narrowed by selecting which trucks or types to view and for what dates and times.

The query items are added in the "AND" condition. If the user selects a truck # and date range, the query will sort the data for that truck number AND the date range.

Sorting on Truck Unit Number

The truck unit number is the truck unit number entered into the payload meter when it was configured at installation. The query can be set to look for all trucks or one particular truck number. When the program begins, it searches through the database for all the unique truck numbers and creates a list to select from.

Choosing one particular truck number will limit the data in the displays, summaries and reports to the one selected truck. To create reports for truck number 374, select 374 from the pull-down menu and hit the "Query Database and Display" button.

Sorting on Truck Type

The truck type is the size of the truck from the family of Komatsu trucks. This allows the user to quickly view results from different types of trucks on the property. For example, a separate report can be generated for 830E and 930E trucks.

No Display on Speedometer

No Display on Operator Display

- If the speedometer works but the operator displays remain blank, confirm payload connections at “No Payload Display When Key Switch is Turned ON”.

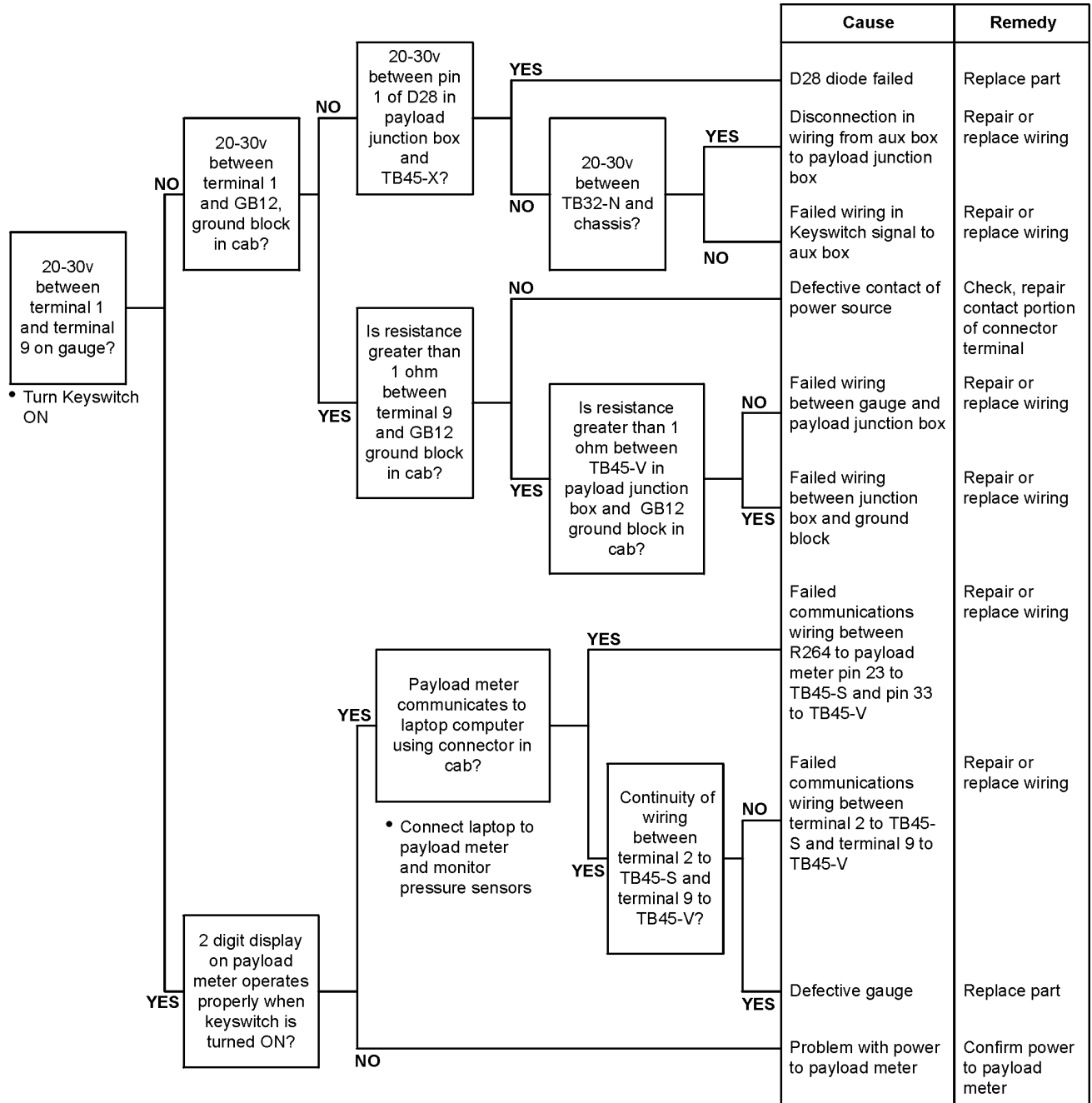

Alarm 18

Payload meter detected an undercharged suspension condition on the rear right suspension.

The suspension may be in need of servicing. Refer to Section H in the shop manual for information on charging the suspensions.

Alarm 19

Payload meter detected an undercharged suspension condition on the rear left suspension.

The suspension may be in need of servicing. Refer to Section H in the shop manual for information on charging the suspensions.

Alarm 22

The payload meter detected an empty carryback load in excess of the user-defined carryback threshold on two consecutive haul cycles.

Stop the truck and clean any stuck material from the truck body.

**SECTION M31
RESERVE ENGINE OIL SYSTEM
INDEX**

RESERVE ENGINE OIL SYSTEM	M31-3
Operation	M31-4
LED Monitor Light	M31-4
Tank Fill Control (Optional)	M31-5
Filling Procedure (Remote fill feature)	M31-5
SERVICE	M31-6
Every 10 Hours, or once each shift:	M31-6
Every 500 Hours:	M31-6
Changing Oil	M31-6
TROUBLESHOOTING	M31-7
Circuit Fuse	M31-7
SYSTEM ELECTRICAL SCHEMATICS	M31-8

TRUCK CAB AND COMPONENTS

TRUCK CAB

Description

The truck cab is a fully insulated design incorporating an integral ROPS structure for maximum operator comfort and safety. All gauges, switches, and controls have been designed to simplify operation and are placed within easy reach of the operator. Servicing of cab and associated electrical systems is simplified by use of heavy duty connectors on the various wiring harnesses. Hydraulic components are located outside the cab interior and are accessed through cover (1, Figure 2-1) on the front of the cab.

⚠ WARNING

DO NOT attempt to modify or repair damage to the ROPS structure without written approval from the manufacturer. Unauthorized repairs to the ROPS structure will void certification. If modification or repairs are required, contact the servicing Komatsu Distributor.

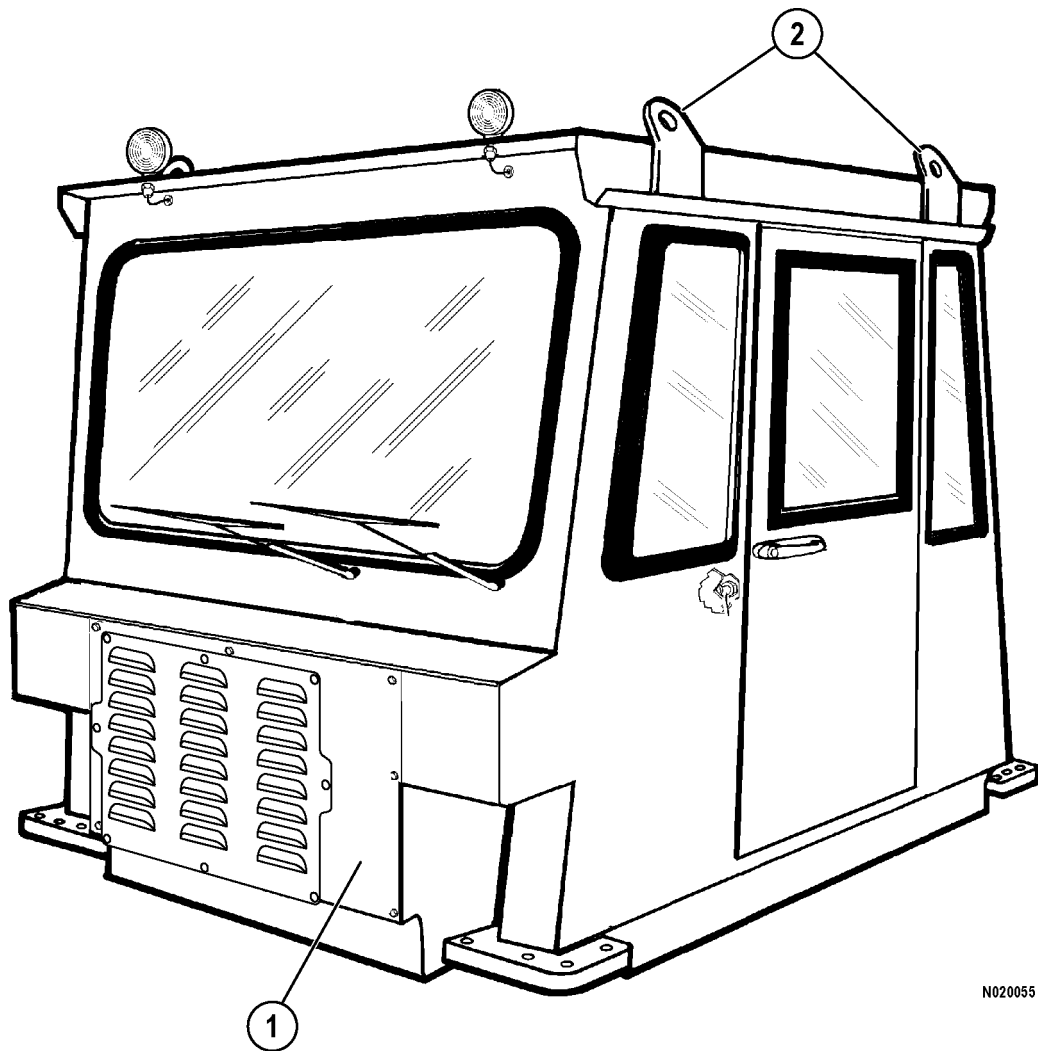

N020055

FIGURE 2-1. CAB ASSEMBLY (FRONT VIEW)

1. Access Cover

2. Lifting Eyes

Replacing the Door and Door Hinge Seal

1. The door assembly seal has only three members to it (sides and top) and is glued on the door. This seal can be replaced by peeling the seal away from the door frame. Then use a suitable cleaner to remove the remaining seal and glue material.
2. The area where the door seal mounts should be free of dirt and oil. Spread or spray a glue which is quick drying and waterproof onto the area where the seal is to be installed.
3. Install the seal so that the corners of the seal fit up into the corners of door frame (3, Figure 2-17).
4. Door hinge seal (2, Figure 2-18) is glued to the hinge. Use the same procedure as above for this seal.

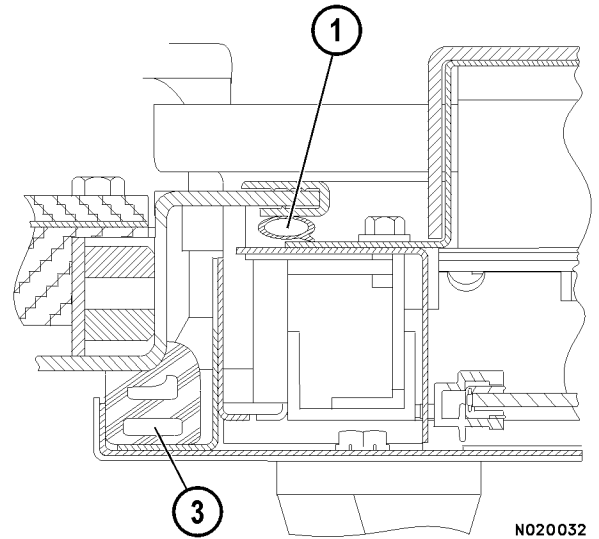

FIGURE 2-17.

Replacing the Door Opening Seal

1. Starting at the lower center of the door opening, pull up on one end of the seal. The seal should pull loose from the cab opening lip. Pull the seal loose all the way around opening (1, Figures 2-17 and 2-18).
2. Inspect the cab opening lip for damage, dirt, and oil. Repair or clean the cab opening as necessary. Remove all dirt and old sealant. Ensure that the perimeter of the opening is clean and free of burrs.
3. Install the seal material around the door opening in the cab. Start at the bottom center of the cab opening and work the seal lip over the edge of the opening. Go all the way around the opening. Ensure that the seal fits tightly in the corners. A soft face tool may be used to work the seal up into the corners.
4. Continue going all the way around the opening. When the ends of the seal meet at the bottom center of the cab opening, it may be necessary to trim off some of the seal.

NOTE: The ends of the seal material need to be square-cut to assure a proper fit.

5. Fit both ends so that they meet squarely. Then while holding the ends together, push them firmly into the center of the opening.

1. Door Opening Seal 3. Door Assembly Seal

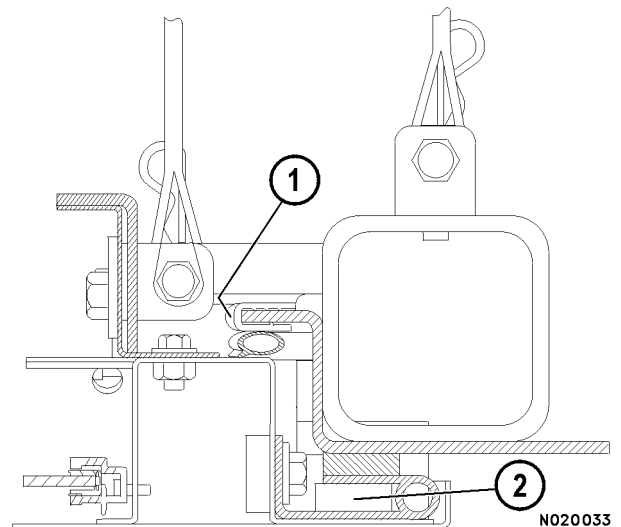

FIGURE 2-18.

1. Door Opening Seal 2. Door Hinge Seal

SECTION N4 HEATER / AIR CONDITIONER INDEX

OPERATION	N4-3
Fan Speed Control Knob	N4-3
Temperature Control Knob	N4-3
Air Flow Directional Knob	N4-4
Heater/Air Conditioner Vents	N4-4
COMPONENTS	N4-4
Fuse and Circuit Breaker	N4-4
Relays	N4-4
Heater Core	N4-5
Fan Motor And Speed Control	N4-5
Actuators	N4-5
Cab Air Filter	N4-5
ENVIRONMENTAL IMPACT OF AIR CONDITIONING	N4-8
AIR CONDITIONING FOR OFF-HIGHWAY VEHICLES	N4-8
PRINCIPLES OF REFRIGERATION	N4-8
Air Conditioning	N4-8
Refrigeration - The Act Of Cooling	N4-9
The Refrigeration Cycle	N4-9
AIR CONDITIONER SYSTEM COMPONENTS	N4-10
Compressor (Refrigerant Pump)	N4-10
Service Valves	N4-10
Condenser	N4-10
Receiver-Drier	N4-10
Expansion Block Valve	N4-11
Accumulator	N4-11
Evaporator	N4-11
ELECTRICAL CIRCUIT	N4-12
Thermostat	N4-12
Compressor Clutch	N4-12
Trinary™ Switch	N4-13
AIR CONDITIONING SYSTEM SERVICING WARNINGS.....	N4-14
SERVICE TOOLS AND EQUIPMENT	N4-15
Recovery/Recycle Station	N4-15
Leak Detector	N4-15
Manifold Gauge Set	N4-16
Installing Manifold Gauge Set	N4-17
Purging Air From Service Hoses	N4-17
Service Valves	N4-18
Vacuum Pump	N4-18
SYSTEM PERFORMANCE TEST	N4-19

Trinary™ Switch

This switch is mounted on the receiver-drier and has three functions, as implied by the name:

1. Disengage the compressor clutch when system pressure is too high.
2. Disengage the compressor clutch when system pressure is too low.
3. Engage and disengage the radiator fan drive clutch during normal variation of system pressure.

The Trinary™ switch performs three distinct functions to monitor and control refrigerant pressure in the system. This switch is installed on the receiver-drier. The switch functions are:

Terminals 1 and 2 are connected internally through two, normally closed pressure switches in series, the low pressure switch and the high pressure switch.

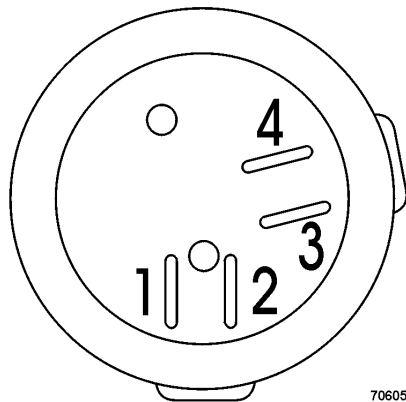

Terminals 3 and 4 are connected internally through a normally open switch that is used to control the clutch that drives the radiator fan. This switch closes and causes the cooling fan clutch to engage when system pressure rises to 1 379 - 1 586 kPa (200 - 230 psi). When pressure falls to 965 - 1 344 kPa (140 - 195 psi), the switch contacts open and the cooling fan clutch disengages.

- Low Pressure - This switch opens and disengages the compressor clutch if system pressure drops into the 103 - 207 kPa (15 - 30 psi) range. When pressure rises above 276 kPa (40 psi), the switch contacts close, and the clutch engages the compressor. Since temperature has a direct effect on pressure, if the ambient temperature is too cold, system pressure will drop below the low range and the pressure switch will disengage the clutch.

- Fan Clutch - The mid-range function actuates the engine fan clutch, if installed.
- High Pressure - This switch opens and disengages the compressor clutch if system pressure rises above the 2 068 - 2 413 kPa (300 - 350 psi) range. After system pressure drops to 1 448 - 1 724 kPa (210 - 250 psi), the switch contacts will close and the clutch will engage.

The switch functions will automatically reset when system pressure returns to normal.

	OPENS	CLOSES
Low Pressure	103 - 207 kPa (15 - 30 psi) descending pressure	276 kPa (40 psi) rising pressure
High Pressure	2068 - 2413 kPa (300 - 350 psi)	1448 - 1724 kPa (210 - 250 psi)
Fan Clutch	241 - 414 kPa (35 - 60 psi) below closing pressure	1379 - 1586 kPa (200 - 230 psi) rising pressure

⚠ IMPORTANT ⚠

The pressures listed above are typical of pressures at the receiver-drier. Due to normal system flow losses and the distance between the service port and the receiver-drier, it is expected that actual system pressure displayed on the gauge will normally be approximately 138 kPa (20 psi) higher. This factor should be observed when checking for proper operation of the switch.

NOTE: One other pressure controlling device is installed within the compressor. A mechanical relief valve is located on the back of the compressor. The relief valve will open at 3 447 - 3 792 kPa (500 - 550 psi). The purpose of this valve is to protect the compressor in the event that pressure should be allowed to rise to that level. Damage to the compressor will occur if pressure exceeds 550 psi.

A/C DRIVE BELT CHECKOUT PROCEDURE

This procedure must be performed each time any component in the accessory drive is serviced, such as replacing a belt or removing the compressor. In addition, a 250 hour inspection of the AC drive belt is mandatory. The belts must be inspected for indications of wear and damage that may hinder performance. Replace as necessary and perform the following procedure.

Pulley Alignment

1. Install alignment tool (EL8868) onto the pulleys to check the alignment. Refer to Figure 4-15. If misalignment of the pulleys exceeds 3 mm (0.13 in.), the position of the compressor must be adjusted.

Belt Tension Check

NOTE: This procedure has been written for use with belt tension tool (XA3379), shown in Figure 4-13. Other tension tools may differ in functionality.



FIGURE 4-13. BELT TENSION TOOL - XA3379

2. Refer to Figure 4-16 for the proper distance from the centerline of the drive pulley to the centerline of the compressor pulley. Set the tension tool accordingly on the "deflection" scale by moving the deflection O-ring to the corresponding distance on the scale.
3. Slide the O-ring for the "force" scale to zero.



FIGURE 4-14. DEFLECTION MEASUREMENT

4. Find the approximate center of the belt between the two pulleys. Place the tip of the tool onto the outer face of the belt and apply pressure, as shown in Figure 4-14. The tool must be perpendicular to the belt. Push on the tool until the bottom edge of the deflection scale O-ring is even with the outer face of the adjacent drive belt. If only one belt is used, rest a straight edge across both pulleys to serve as the indicating plane.
5. The O-ring on the force scale indicates the force used to deflect the belt. The belt must deflect 5.3 mm (0.21 in.) under a force of 1.6 ± 0.1 kgf (3.44 ± 0.11 lbf). If not, adjust the belt accordingly and recheck the tension.

PROBLEM: Extremely Low Refrigerant Charge in the System

Indications:

Low side pressure - LOW.
High side pressure - LOW.
Discharge air is warm.
The low pressure switch may have shut off the compressor clutch.

Possible Causes

- Extremely low or no refrigerant in the system.
Possible leak in the system.

Suggested Corrective Actions

Check for leaks by performing leak test.

No Leaks Found:

Recover refrigerant from the system. Recharge using a scale to ensure correct charge. Check A/C operation and performance.

Leaks Found:

Add refrigerant (make sure system has at least 50% of its normal amount) and leak test system. It may be necessary to use a jumper wire to enable the compressor to operate, if the compressor has shut down due to faulty pressure sensing switch. Repair any leaks and evacuate the system if necessary. Replace the receiver-drier if the system was opened. Recharge the system using a scale and add oil as necessary. Check A/C operation and do system performance test.

PROBLEM: Air and/or Moisture in the System

Indications:

Low side pressure - Normal
High side pressure - Normal
Discharge air is only slightly cool.
(In a cycling type system with a thermostatic switch, the switch may not cycle the clutch on and off, so the low pressure gauge will not fluctuate.)

Possible Causes

Leaks in the system.

Suggested Corrective Actions

Test for leaks, especially around the compressor shaft seal area. When the leak is found, recover refrigerant from the system and repair the leak. Replace the receiver-drier or accumulator because the desiccant may be saturated with moisture. Check the compressor and replace any refrigerant oil lost due to leakage. Evacuate and recharge the system with refrigerant using a scale. Check A/C operation and performance.

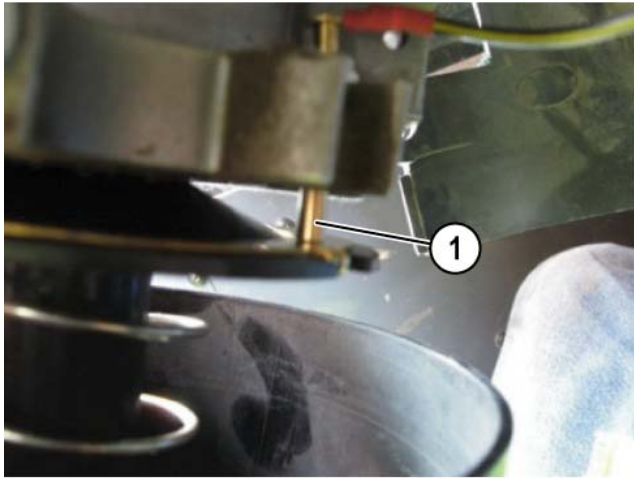

PREVIOUS DESIGN

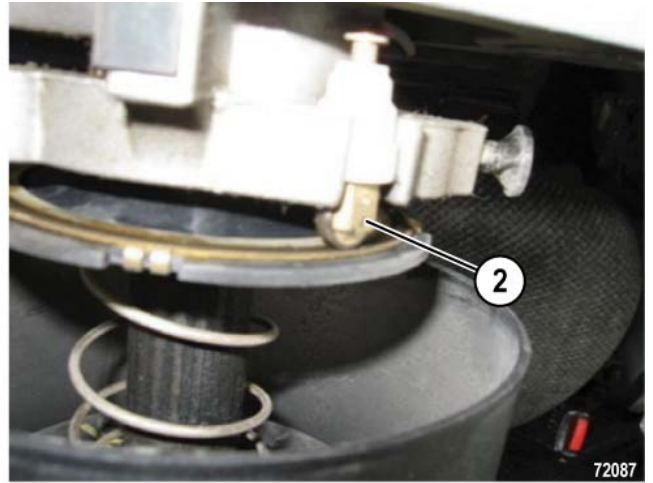

NEW DESIGN

FIGURE 5-4. HORN CONTACTS

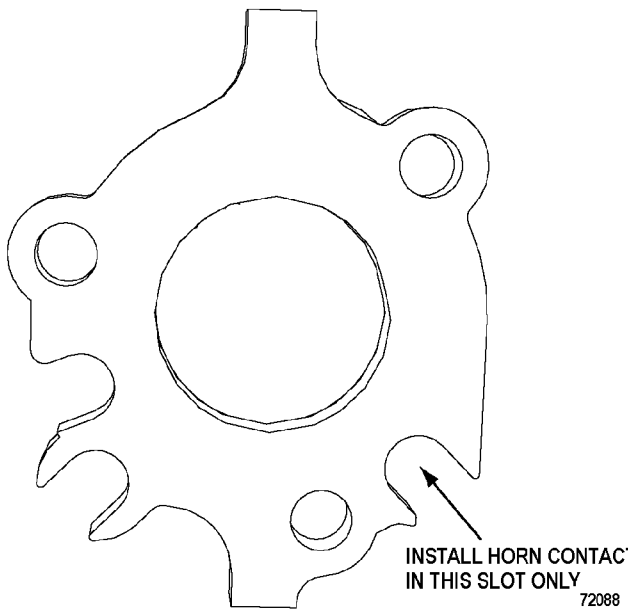
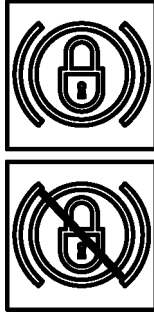

FIGURE 5-5. INSTALLATION LOCATION

Wheel Brake Lock Switch

Wheel brake lock switch (5, Figure 5-9) should be used with engine running for dumping and loading operations only. The brake lock switch actuates the hydraulic brake system which locks the **rear wheel service brakes only**. When pulling into shovel or dump area, stop the truck using the foot-operated service brake pedal. When truck is completely stopped and in loading position, apply the brake lock by pressing the top of the rocker switch. To release the brake, press the bottom of the rocker switch.



NOTE: Use at the shovel and dump only to hold the truck in position.



Do not use the wheel brake lock switch to stop the truck unless foot-operated treadle valve is inoperative. Use of this switch applies rear service brakes at a reduced, unmodulated pressure. Do not use brake lock for parking. With engine stopped, hydraulic pressure will bleed down, allowing brakes to release.

Hazard Warning Lights

Hazard warning light switch (6, Figure 5-9) flashes all the turn signal lights. Pressing the bottom of the rocker switch activates these lights. Pressing the top of the rocker switch turns these lights off.



Heater/Air Conditioner Vents

Heater/air conditioner vents (7, Figure 5-9) may be directed by the operator to provide the most comfortable cabin air flow.

Engine Oil Pressure Gauge

Engine oil pressure gauge (8, Figure 5-9) indicates pressure in the engine lubrication system.

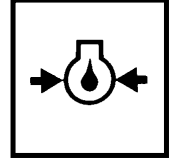

Normal operating pressure after engine warm-up should be:

Idle: 138 kPa (20 psi) minimum

Rated Speed: 310 - 483 kPa (45 - 70 psi)

Right Turn Signal Indicator

Indicator (9, Figure 5-9) illuminates to indicate that the right turn signals are operating when the turn signal lever on the steering column is moved upward. Moving the lever to its center position will turn the indicator off.

Digital Tachometer

Digital tachometer (10, Figure 5-9) registers engine crankshaft speed in hundreds of revolutions per minute (rpm).

Governed Speed	
Low Idle	750 rpm
High Idle	1910 rpm
Full Load	1900 rpm

High Beam Indicator

When lit, high beam indicator (11, Figure 5-9) indicates that the headlights are on high beam. To switch the headlights to high beam, push the turn indicator lever away from the steering wheel. For low beam, pull the lever toward the steering wheel.

Speedometer/Payload Meter Display

Speedometer/payload meter display (12, Figure 5-9) indicates the truck speed in kilometers per hour (kph) or in miles per hour (mph). The display also shows payload meter information. For more information, see Section M20, Payload Meter III.

Orbcomm controller (3, Figure 5-13) transmits data through antenna (1, Figure 5-14) mounted on top of the cab. The antenna coaxial cable is routed through the inside of the cab to protect it from damage. If the antenna or coaxial cable is damaged, replace the parts.

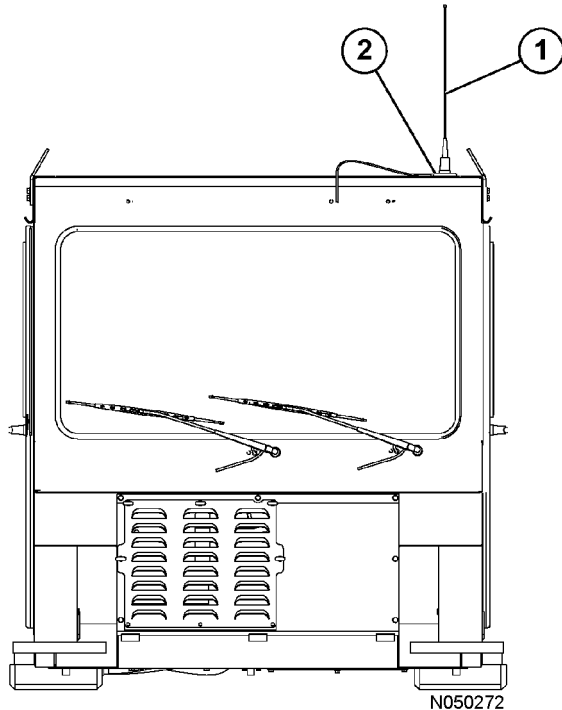

FIGURE 5-14. ORBCOMM ANTENNA

1. Orbcomm Antenna 2. Magnetic Base

Interface Module

Interface module (3, Figure 5-13) receives data from the sensors installed on the truck and sends this information to the KOMTRAX Plus controller. There is a small green LED light on the face of the controller. With the key switch ON, the light must be blinking. If the light is continuously illuminated, there is a problem in the controller.

When a new interface module controller is installed on the truck, new software has to be installed inside the controller. IM-Diag connector (1, Figure 5-15) is used to connect the interface module to a laptop PC for installing software.

Basic Precautions

- When using this truck, there is no particular need to operate the KOMTRAX Plus system.
- Never disassemble, repair, or modify the KOMTRAX Plus system. This may cause failure or fire on the machine or this system.
- Do not touch the system when operating the machine.
- Do not pull on the wiring harnesses, connectors, or sensors of this system. This may cause short circuits or disconnections that lead to failure or fire on the machine or this system.
- Do not get water, dirt or oil on the system controllers.
- If there is any abnormality with the KOMTRAX Plus system, please consult the servicing Komatsu distributor.

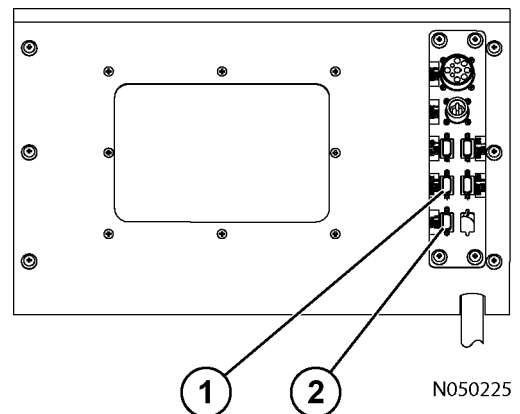

FIGURE 5-15. DIAGNOSTIC PORTS (D.I.D. PANEL AT REAR OF CAB)

1. IM Diagnostic Port
2. KOMTRAX Plus Diagnostic Port

RESERVE OIL TANK SERVICE

The reserve engine oil system is designed to add more oil capacity to the engine to reduce the frequent servicing of the engine oil. The engine oil level must still be checked every shift by using the dipstick. If the engine oil level is not correct, check for proper operation of the reserve engine oil system. Never add oil to the engine unless it has been drained.

If the engine oil has been drained from the oil pan, new oil must be added to the engine oil pan before starting. Do not use the oil in the reserve tank to fill an empty engine with oil. After an oil change, both the engine and reserve tank must be full of oil before starting the engine.

With the engine running, check the operation of the red LED light on the pump.

- **Continuously on** - Pump 1 is withdrawing oil from the engine sump and bringing down the oil level.
- **Regular pulsing** - Pump 2 is returning oil to the engine sump and raising the oil level.
- **Irregular pulsing** - Oil is at the correct running level.

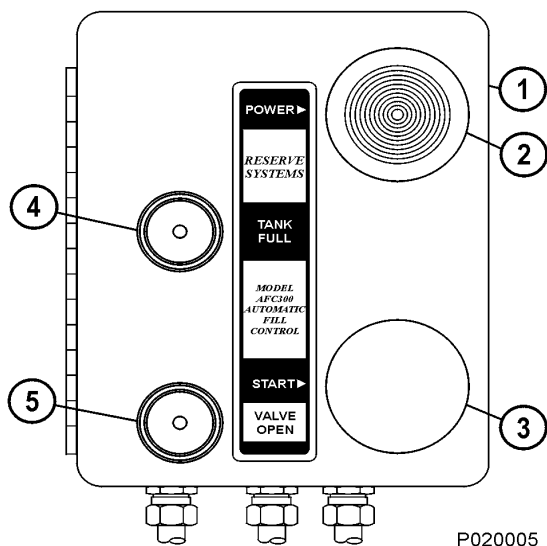

FIGURE 2-3. REMOTE FILL CONTROL BOX

- | | |
|-----------------------|---------------------|
| 1. Remote Control Box | 4. FULL Light |
| 2. Power Switch | 5. VALVE OPEN Light |
| 3. Start Switch | |

Oil should always be visible in the bottom sight gauge. If not, add oil to the reserve oil tank until oil is visible in the top sight gauge.

- Never add oil to the engine unless it has been completely drained.
- If the engine oil has been drained from the oil pan, new oil must be added to the oil pan. **Do not use the oil in the reserve oil tank to fill an empty engine oil pan.**
- After an oil change, both the engine and reserve oil tank must be full of oil before starting the engine.

Filling the Reserve Oil Tank (Remote Fill)

1. Connect the supply hose from the new oil supply to the quick disconnect coupling on the truck. Open the valve on the supply hose to apply pressure.
2. Pull power switch (2, Figure 40-3) to turn the system ON.
3. Push start switch (3). VALVE OPEN light (5) should illuminate and the filling process will begin.
4. When tank is full, VALVE OPEN light (5) will turn off and FULL light (4) will illuminate.
5. Close the valve in the supply hose.
6. Press and hold start switch (3) for a couple of seconds.
7. Disconnect the supply hose from the quick disconnect coupling on the truck.
8. Push power switch (2) to turn the system OFF.

Inline Screen

There is an inline screen located at the inlet of the fill valve. This screen does not require periodic maintenance, but it can be cleaned by removing the screen and back flushing.

CLICK HERE TO **DOWNLOAD** THE COMPLETE MANUAL

- Thank you very much for reading the preview of the manual.
- You can download the complete manual from: www.heydownloads.com by clicking the link below



- Please note: If there is no response to CLICKING the link, please download this PDF first and then click on it.

CLICK HERE TO **DOWNLOAD** THE COMPLETE MANUAL