

SHOP MANUAL



3D82AE SERIES

3D84E SERIES

3D88E SERIES

4D88E SERIES

4D98E SERIES

4D106 SERIES

S4D84E SERIES

S4D98E SERIES

S4D106 SERIES

DIESEL ENGINE



CLICK HERE TO **DOWNLOAD** THE COMPLETE MANUAL

- Thank you very much for reading the preview of the manual.
- You can download the complete manual from: www.heydownloads.com by clicking the link below



- Please note: If there is no response to CLICKING the link, please download this PDF first and then click on it.

CLICK HERE TO **DOWNLOAD** THE COMPLETE MANUAL

- Contents omitted in this manual

Though the following jobs are omitted in the explanation in this manual, they should be conducted in actual work:

- 3) Jacking up and lifting
- 4) Cleaning and washing of removed parts as required
- 5) Visual inspection

(3) Definition of Terms

[NOTICE]: Instruction whose negligence is very likely to cause an accident. Always observe it.

Standard: Allowable range for inspection and adjustment.

Limit: The maximum or minimum value that must be satisfied during inspection or adjustment.

(4) Abbreviations

Abbreviation	Meaning	Abbreviation	Meaning
Assy	assembly	T.D.C.	top dead center
Sub-Assy	sub-assembly	B.D.C.	bottom dead center
a.T.D.C	after top dead center	OS	oversize
b.T.D.C	before top dead center	US	undersize
STD	Standard	Min ⁻¹	revolutions per minute
IN	Intake	PS	Output (metric horsepower)
EX	Exhaust	T	Bolt/nut tightening torque

(4) 3TNV88

Engine name		Unit	3TNV88								
Engine specification class		-	CL	VM							
Type		-	Vertical, in-line, 4-cycle, water-cooled diesel engine								
Combustion chamber		-	Direct injection								
Number of cylinders		-	3								
Cylinder borexstroke		mm× mm	88×90								
Displacement		L	1.642								
Continuous rating	Revolving speed	Min ⁻¹	1500	1800	-						
	Output	kW (hp)	12.3 (16.7)	14.8 (20.1)	-						
Rated output	Revolving speed	Min ⁻¹	1500	1800	2000	2200	2400	2500	2600	2800	3000
	Output	kW (hp)	13.5 (18.4)	16.3 (22.1)	18.0 (24.5)	19.9 (27.0)	21.6 (29.4)	22.6 (30.7)	23.5 (31.9)	25.2 (34.2)	27.1 (36.8)
Max. no-load speed (±25)		min ⁻¹	1600	1895	2180	2400	2590	2700	2810	2995	3210
Ignition order		-	1-3-2-1(No.1 cylinder on flywheel side)								
Power take off		-	Flywheel								
Direction of rotation		-	Counterclockwise (viewed from flywheel)								
Cooling system		-	Radiator								
Lubrication system		-	Forced lubrication with trochoid pump								
Starting system		-	Electric								
Applicable fuel		-	Diesel oil-ISO 8217 DMA, BS 2869 A1 or A2 (Cetane No.45 min.)								
Applicable lubricant		-	API grade class CD or CF								
Lubricant capacity (oil pan) *	Total	L	4.7						7.2		
	Effective	L	1.8						3.5		
Coolant water capacity (engine only)		L	2.0								
Engine dimensions ** (with flywheel housing)	Overall length	mm	589			564					
	Overall width	mm	486								
	Overall height	mm	622								
Engine mass (dry) ** (with flywheel housing)		kg	155								
Cooling fan (std.)		Mm	350 mm O/D, 6 blades pusher type								
Crankshaft V pulley diameter & Fun V pulley diameter (std.)		Mm	120×90			120×90					

* Engine oil capacity may differ from the above depending on an engine installed on a machine unit.

** Engine mass and dimensions without radiator

1.3.2 Lubricating oil

IMPORTANT:

Use of other than the specified engine oil may cause inner parts seizure or early wear, leading to shorten the engine service life.

(1) Selection of engine lube oil

Use the following engine oil

- API classification CD or CF
(Standards of America Petroleum Institute)
- SAE viscosity 10W-30 or 15W-40
(Standard of Society of Automotive Engineering)

Engine oil with 10W30 or 15W40 can be used throughout the year.

(Refer to the right figure.)

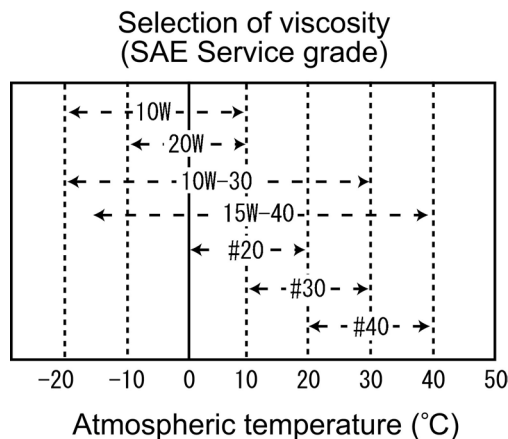

15W-40/10W-30 can be used almost throughout the year.

(2) Handling of engine oil

- Carefully store and handle the oil so as to prevent dust or dirt entrance. When supplying the oil, pay attention and clean around the filler port.
- Do not mix different types of oil as it may adversely affect the lubricating performance.

CAUTION

When touching engine oil by hand, the skin of the hand may become rough. Be careful not to touch oil with your hands without protective gloves. If touch, wash your hands with soap and water thoroughly.

1.3.3 Coolant water

Use clean soft water and be sure to add the Long Life Coolant Antifreeze (LLC) in order to prevent rust built up and freezing. If there is any doubt over the water quality, distilled water or pre-mixed coolant should be used.

The coolants / antifreezes, which are good performance for example, are shown below.

- TEXACO LONG LIFE COOLANT ANTIFREEZE, both standard and pre-mixed.
Product codes 7997 and 7998
- HAVOLINE EXTENDED LIFE ANTIFREEZE / COOLANT
Product code 7994

IMPORTANT:

- Be sure to add Long Life Coolant Antifreeze(LLC) to soft water. In cold season, the LLC is especially important. Without LLC, cooling performance will decrease due to scale and rust in the coolant water line. Without LLC, coolant water will freeze and expand to break the cooling line.
- Be sure to use the mixing ratios specified by the LLC manufacturer for your temperature range.
- Do not mix different types (brand) of LLC, chemical reactions may make the LLC useless and engine trouble could result.
- Replace the coolant water every once a year.

CAUTION

When handling Long Life Coolant Antifreeze, wear protective rubber gloves not to touch it. If LLC gets eyes or skin, wash with clean water at once.

IMPORTANT:

If the coolant water runs short quickly or when the radiator runs short of water with the Coolant recovery tank level unchanged, water may be leaking or the air tightness may be lost. Increase in the Coolant recovery tank water level during operation is not abnormal.

The increased water in the Coolant recovery tank returns to the radiator when the engine is cooled down.

If the water level is normal in the Coolant recovery tank but low in the radiator, check loosened clamping of the rubber hose between the radiator and Coolant recovery tank or tear in the hose.

Standard

Engine: The radiator shall be filled up.

(Unit: liter)

Model	Coolant water volume In an engine
3TNV82A	1.8
3TNV84(T) 3TNV88	2.0
4TNV84(T) 4TNV88	2.7
4TNV94L 4TNV98(T)	4.2
4TNV106(T)	6.0

Engine coolant water capacity may differ from the above volume depending on an engine installed on a machine unit.

(5) Fuel pipe and coolant water pipe inspection and maintenance

Check the rubber hoses for fuel and coolant water pipes cracked. If the cracked hose is found, replace it with new one. Check the loosened clamp. If found, tighten it.

(6) Inspection and adjustment of governor lever and accelerator

Make sure the accelerator of the machine unit can be operated smoothly before starting the engine. If it feels heavy to manipulate, lubricate the accelerator cable joints and pivots. Adjust the accelerator cable if there is a dislocation or excessive play between the accelerator and the governor lever. Refer to 3.2.3.

(7) Warning lamp & instruments function check

Before and after starting the engine, check to see that the alarm function normally. Failure of alarm cannot warn the lack of the engine oil or the coolant water. Make it a rule to check the alarm operation before and after starting engine every day. Refer to each manual for machine units in details.

2.2.2 inspection after initial 50 hours operation

Be sure to check the following points after initial 50 hours operation, thereafter every 250 hours or 3 months operation.

No.	Inspection Item
(1)	Lube oil and filter replacement
(2)	V-belt tension check

(1) Lube oil and filter replacement (1st time)

When an engine is still hot, be careful with a splash of engine oil which may cause burns. Replace engine oil after the engine oil becomes warm. It is most effective to drain the engine oil while the engine is still warm.

2.2.5 Inspection every 500 hours or 6 months

Be sure to check the following points every 500 hours or 6 months operation, whichever comes first.

No.	Inspection Item
(1)	Water separator cleaning
(2)	Fuel filter element replacement
(3)	Air cleaner cleaning and element replacement

(1) Water separator cleaning

Periodically wash the water separator element and inside cup with clean fuel oil.

- 1) Prepare a waste oil container.
- 2) Close the fuel cock.
- 3) Loosen the drain cock and drain.
Refer to 2.2.3.(2)
- 4) Turn the retaining ring counter-clockwise and remove the cup.
(Disconnect the coupler of the lead wire for drain sensor before removing the cup if it is with drain sensor).
- 5) Wash the element and inside cup with clean fuel oil. Replace the element with new one if any damaged.

Model	Applicable element	Part No.
3TNV82A~ 4TNV106(T)		119802-55710

- 6) Insert the element to the bracket (O-ring) and after putting the float ring in the cup, install it to the bracket by tightening the retaining ring clockwise.
Tightening torque: 15~20Nm (1.5~2.0kgf-m)
- 7) Close the drain cock (connect the coupler if with drain sensor).
- 8) Bleed the fuel system. Refer to 2.2.3.(3)

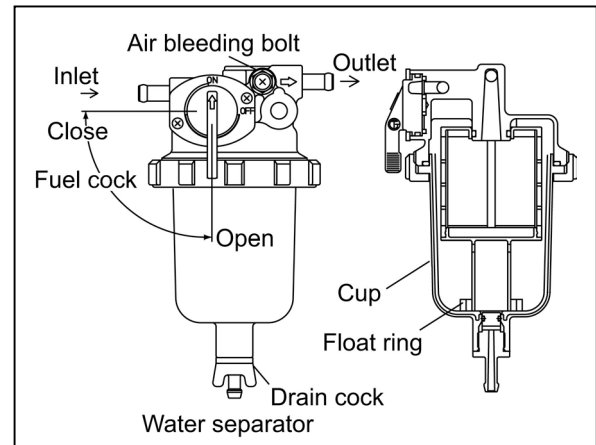

Spray and injection states

- Operate the nozzle tester lever at a rate of once or twice a second and check no abnormal injection.
- If normal injection as shown below cannot be obtained, replace the fuel injection valve.
- No extreme difference in angle(θ)
- No extreme injection angle difference(α)
- Finely atomized spray
- Excellent spray departure

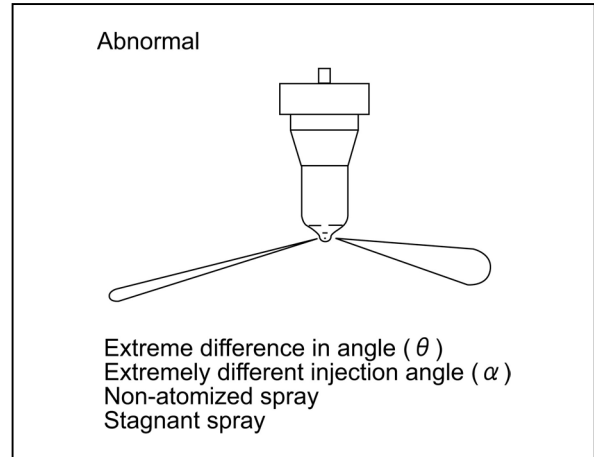

(c) Nozzle valve sliding test

Wash the nozzle valve in clean fuel oil. Place the nozzle body vertically and insert the nozzle into the body to about 1/3 of its length. The valve is normal if it smoothly falls by its own weight into the body. In case of a new nozzle, remove the seal peel, and immerse it in clean diesel oil or the like to clean the inner and outer surfaces and to thoroughly remove rust-preventive oil before using the nozzle. Note that a new nozzle is coated with rust-preventive oil and is pasted with the seal peel to shut off outer air.

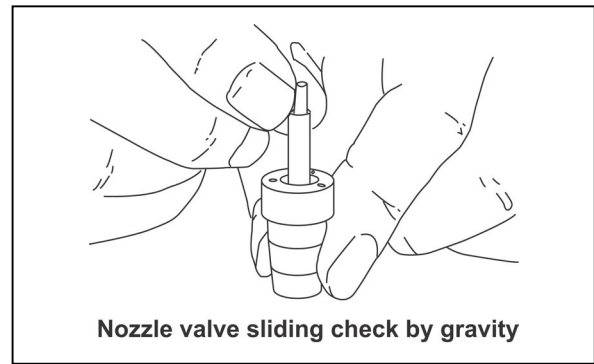

(d) Nozzle punch mark

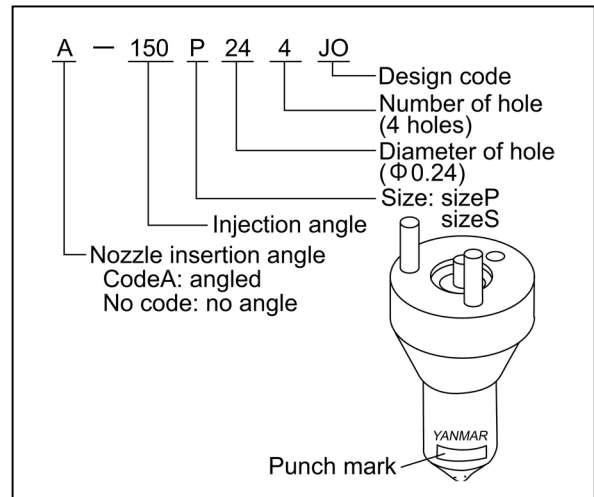

4.1.3 Complete disassembly

Peripheral parts such as air cleaner, muffler and radiator differ in installation and types for each application. Therefore, description in this Chapter is started with the steps to be taken just after the peripheral parts have been removed.

Step	Removal Parts	Remarks
1	<ol style="list-style-type: none"> 1) Thoroughly remove sand, dust, dirt and soil from the surface of the engine. 2) Drain coolant water and lubricating oil from the engine. 	
2	<ol style="list-style-type: none"> 1) Remove turbocharger and exhaust manifold. 2) Remove intake manifold and surge tank. 	
3	<ol style="list-style-type: none"> 1) Close the fuel cock valve of the fuel tank. 2) Remove high-pressure fuel pipe. 3) Remove fuel return pipe. 4) Loosen the tightening nut on fuel injection nozzle retainer and extract the retainer and fuel injection nozzle. <p>*) Fuel injection nozzle for Indirect injection system is screwed type.</p>	<ol style="list-style-type: none"> 1) If nozzle seat is left on the cylinder head, remove the cylinder head before extracting nozzle seat. 2) To prevent dust from entering fuel injection nozzle, fuel injection pump and high-pressure fuel pipe, seal their respective threads with a tape or the like. 3) Whenever extracting fuel injection nozzle, replace nozzle protector with a new one.
4	<ol style="list-style-type: none"> 1) Remove rocker arm cover assembly. 	
5	<ol style="list-style-type: none"> 1) Remove valve rocker arm shaft assembly. 2) Remove push rod. 	<ol style="list-style-type: none"> 1) Attach a tag to push rod for each cylinder No. to put the push rod in order. 2) Remove valve cap from the intake/exhaust valve head. 3) Note that tappet of the indirect injection system can be removed at the same time when push rod is extracted. 4) Attach a tag to tappet for each cylinder No. to put the tappet in order.
6	<ol style="list-style-type: none"> 1) Remove fan mounting bolt, and then remove fan. 2) Loosen adjusting bolt for the V-belt adjuster, and then remove V-belt. 3) Remove alternator. 4) Remove the spacer for cooling fan and V-pulley. 	<ol style="list-style-type: none"> 1) Never turn down alternator vigorously toward the cylinder block. Otherwise, your finger may be nipped and alternator broken.
7	<ol style="list-style-type: none"> 1) Remove lubricating oil filter assembly. 2) Extract dipstick form the oil dip-stick hole. 	
8	<ol style="list-style-type: none"> 1) Disconnect fuel return pipes to. 2) Remove fuel filter. 	

Point9

[Disassemble]

- Carefully remove the fuel injection valve so as not to leave the top end protector from being left inside the cylinder.

[Reassemble]

- Replace the fuel injection valve protector with a new one.

Point10

[Disassemble]

- When removing each intake/exhaust valve from the cylinder head, use a valve spring compressor (see 11.1-4 in Chapter 11) and compress the valve spring and remove the valve cotter.)
- Keep each removed intake/exhaust valve after attaching a tag showing the corresponding cylinder No.
- If cotter burr is seen at the shaft of each intake/exhaust valve stem, remove it with an oilstone and extract the valve from the cylinder head.

[Reassemble]

- Replace the stem seal with a new one when an intake/exhaust valve is disassembled.
- Carefully install each valve after oil application so as not to damage the stem seal.
- Different stem seals are provided for the intake and exhaust valves. Do not confuse them since those for exhaust valves are marked with yellow paint.
- After assembling the intake/exhaust valve, stem seal, valve spring, seat, and cotter, tap the head of the valve stem lightly for settling.
- Do not forget to install the valve cap.

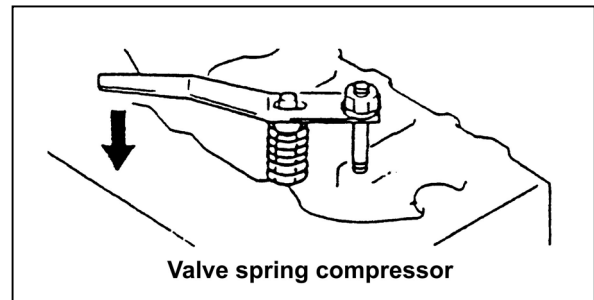

Point3: (Refer to 7.2.5 in chapter 7)

[Disassemble]

- Remove the mounting nut of the fuel injection pump drive gear, remove the gear using the gear puller, and remove the fuel injection pump. Do not forget to remove the stay on the rear side. When extracting the gear using the gear puller, use a pad at the shaft and carefully operate so as not to damage the thread.

[Reassemble]

- Tightening torque for fuel pump drive gear nut (without lube. Oil)

N·m(kgf-m)	
Model	Tightening torque
TNV82A~88	78~88 (8.0~9.0)
4TNV94L/98/106(T)	113~123 (11.5~12.5)

Point4

[Reassemble]

- Assemble crankshaft gear A, fuel injection pump drive gear B and camshaft gear C at the same time by aligning with idle gear A, B and C marks.
- Install the idle gear shaft with the oil hole facing upward.

Point5

[Reassemble]

- Install the PTO drive gear with its inner spline side facing the flywheel.

Point6

[Disassemble]

- Install a bolt as a handle in the hole at the end face of the flywheel and remove carefully so as not to damage the ring gear.

[Reassemble]

Flywheel mounting bolt : apply lube oil

N·m(kgf-m)	
Model	Tightening torque
3TNV82A~88	83.3~88.2 (8.5~9.0)
4TNV94L/98/106(T)	186.2~205.8 (19.0~21.0)

Point7

[Disassemble]

- Measure the camshaft side gap.

mm		
Item	Standard	Limit
Side gap	0.05~0.20	0.30

- If the measured side gap exceeds the limit, replace the thrust metal.

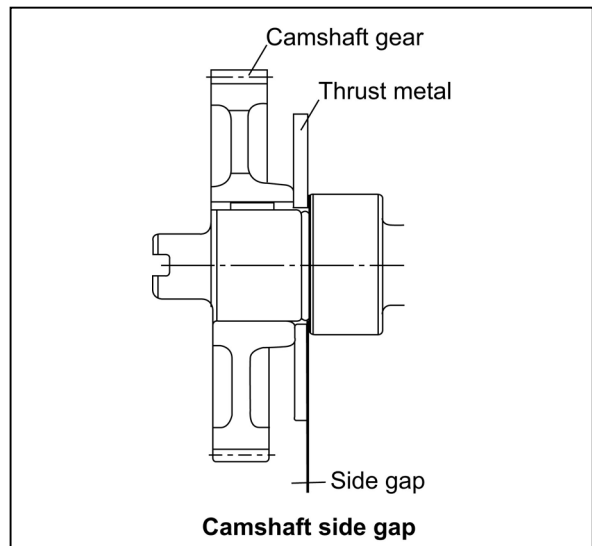

4.4.5 Parts inspection and measurement

(1) Cylinder block

Especially clean head surface, cylinder bores and oil holes, and check after removing any carbon deposit and bonding agent.

(a) Appearance inspection

Check if there is any discoloration or crack. If crack is suspected, perform color check. Sufficiently clean the oil holes and check they are not clogged.

(b) Cylinder bore and distortion

Measure at 20 mm below the crest of the liner, at 20 mm from the bottom end and at the center.

Roundness:

Roundness is found as follows though it is the simple method. Measure cylinder diameters of the A direction and the B direction on each section of a, b and c.

Roundness is the maximum value among those difference values.

Cylindricity:

Cylindricity is found as follows though it is the simple method.

Measure cylinder diameters of a, b and c sections in the A direction, and calculate the difference in maximum value and minimum value of the measured diameters.

In the same way measure and calculate the difference in the B direction.

Cylindricity is the maximum value between those difference values.

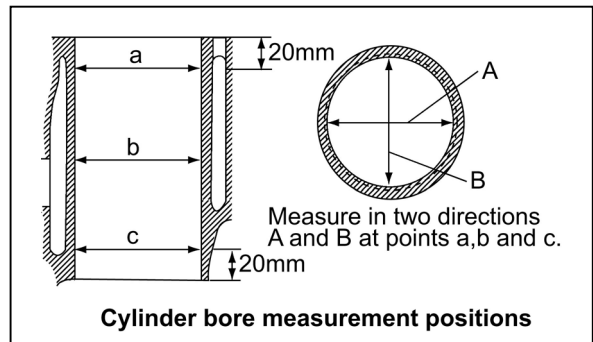
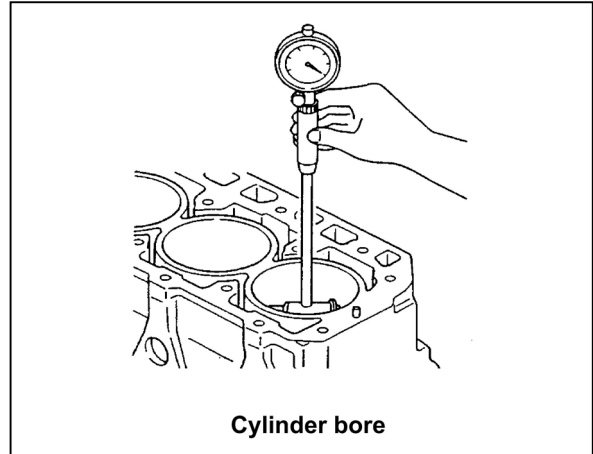

Item		Model	Standard	Limit
Cylinder inside diameter		3TNV82A	82.000~82.030	82.200
		TNV84	84.000~84.030	84.200
		TNV88	88.000~88.030	88.200
		4TNV94L	94.000~94.030	94.130
		4TNV98	98.000~98.030	98.130
		4TNV106(T)	106.000~106.030	106.130
Cylinder bore	Roundness	all TNV	0.01 or less	0.03
	Cylindricity			

mm

(d) Rod big end measurement

Measure the crankpin and bushing according to 4.4.5.(2)(c) described above.

Calculate the oil clearance of a crank pin metal and a crank pin from the measured values of the crank pin metal inner diameter and the crank pin outside diameter.

Replace a crank pin metal if the oil clearance becomes about the limit dimension of the below table.

Correct by grinding if unevenly wear, roundness exceeding the limit or insufficient outside diameter is found. Also use an undersized metal. (Refer to the above (2) c.)

[NOTICE]

When measuring the inside diameter of the rod big end, install the crankpin metals in the rod big end not to mistake the top and bottom of the metals and tighten the rod bolts by the standard torque.

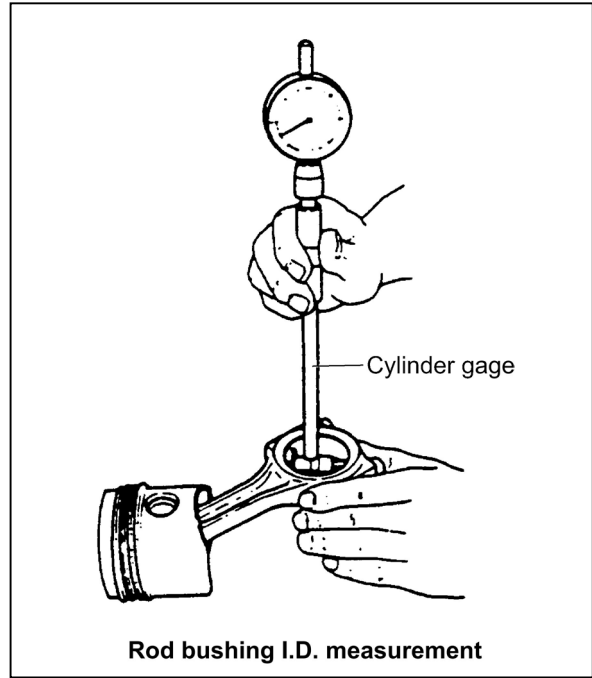

Tightening torque of rod bolt

Model	Tightening torque Nm(kgf-m)	Lubricating oil application (threaded portion, and bearing seat surface)
3TNV82A	37.2~41.2 (3.8~4.2)	Lube. oil applied
TNV84/88	44.1~49.0 (4.5~5.0)	
4TNV94L/98	53.9~58.8 (5.5~6.0)	
4TNV106(T)	78.5~83.4 (8.0~8.5)	

Standard of rod big end

mm

Model	Item	Standard	Limit
3TNV82A	Rod I.D. bushing	42.952~42.962	42.902
	Crankpin O.D.	43.000~43.042	-
	Metal thickness	1.487~1.500	-
	Clearance	0.038~0.090	0.150
TNV84/88	Rod I.D. bushing	47.952~47.962	47.902
	Crankpin O.D.	48.000~48.026	-
	Metal thickness	1.492~1.500	-
	Clearance	0.038~0.074	0.150
4TNV94L/98	Rod I.D. bushing	57.952~57.962	57.902
	Crankpin O.D.	58.000~58.026	-
	Metal thickness	1.492~1.500	-
	Clearance	0.038~0.074	0.150
4TNV106(T)	Rod I.D. bushing	63.952~63.962	63.902
	Crankpin O.D.	64.016~64.042	-
	Metal thickness	1.984~1.992	-
	Clearance	0.054~0.090	0.150

7.2.2 External view and components

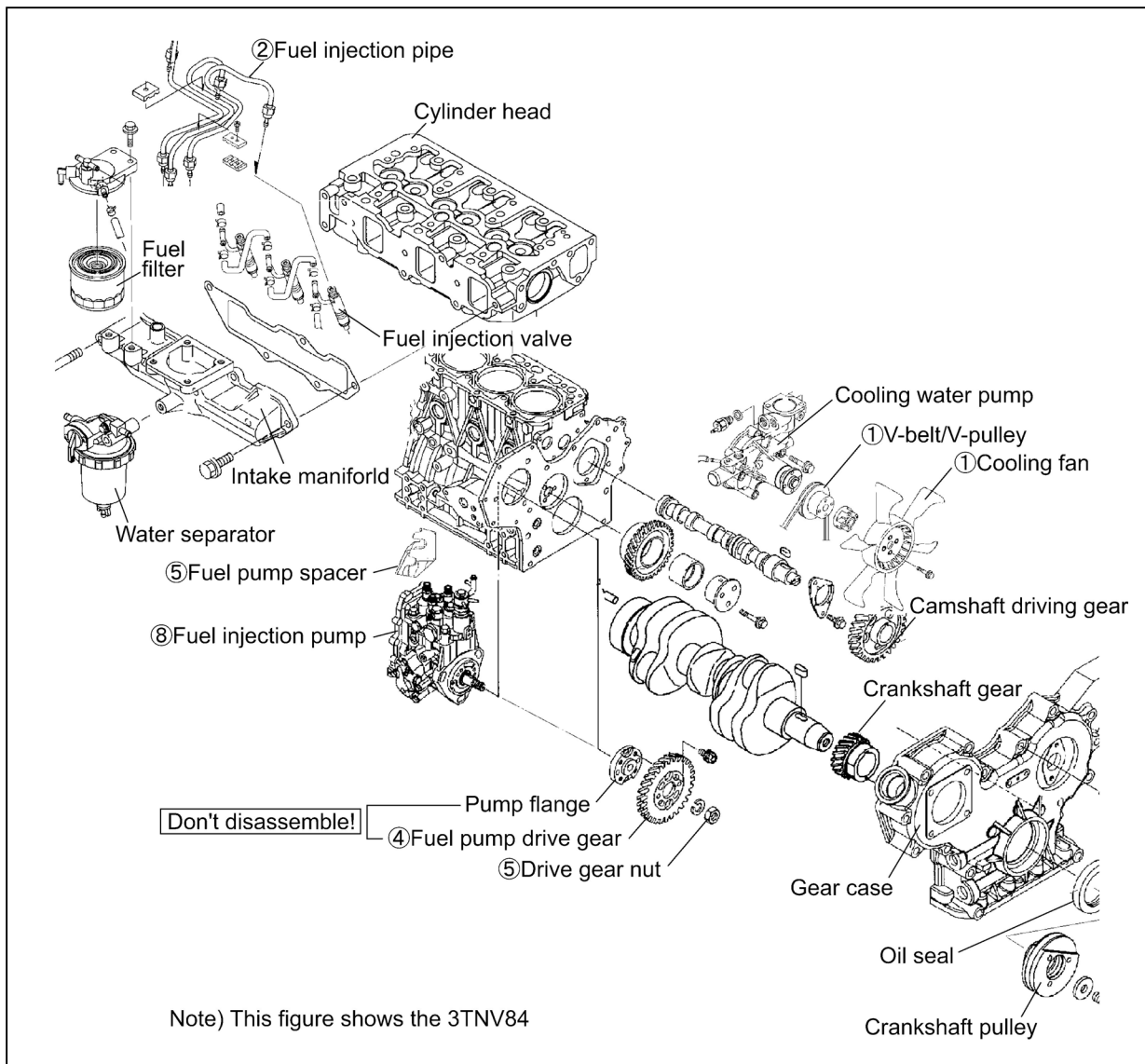

7.2.3 Disassembly procedure:

Disassembly from the engine body

- 1) Remove the cooling fan, pulley and V-belt.
- 2) Remove the fuel injection pipe, fuel oil piping, fuel return pipe and rear stay. See point 1 of 7.2.5.
- 3) Remove the fuel injection pump cover (the cover of the drive gear).
- 4) Make ID marks on the gearing part of the pump drive gear and the idle gear with paint and so on. See Point 2 of 7.2.5.
- 5) Loosen a fuel pump drive gear nut, and remove a pump drive gear from the fuel pump by using a gear puller. See Point 3 of 4.3.4.
- 6) Remove a drive gear nut carefully not to drop it to the inside of the gear case.
- 7) Record the installation angle of the fuel pump precisely by using a mark-off line and a sticker. See (4) of 2.2.7.
- 8) Remove the fuel injection pump. See Point 3 of 7.2.5.

CLICK HERE TO **DOWNLOAD** THE COMPLETE MANUAL

- Thank you very much for reading the preview of the manual.
- You can download the complete manual from: www.heydownloads.com by clicking the link below



- Please note: If there is no response to CLICKING the link, please download this PDF first and then click on it.

CLICK HERE TO **DOWNLOAD** THE COMPLETE MANUAL

8.3.3 Waste gate valve adjustment procedure

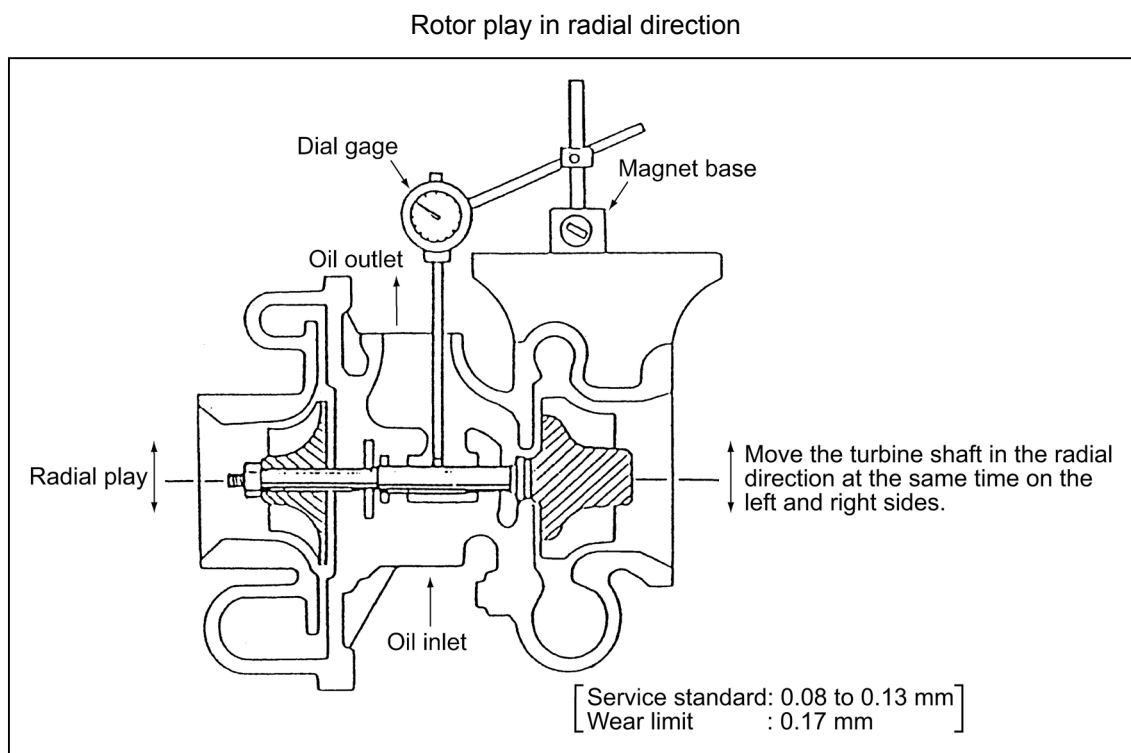

It is indispensable to adjust the waste gate valve opening pressure and lift after its overhaul or inner parts replacement. Negligence of this adjustment will adversely affect the engine performance.

[NOTICE]

If the adjustment is impossible, give up overhaul but replace the whole turbocharger assembly.

(1) Method for checking the waste gate valve opening pressure and lift

(a) Equipment

Prepare the equipment shown in the figure below.

(3) Thrust bearing installation

- 1) Fit thrust bushing on turbine shaft 1.
- 2) Apply lubricating oil on the bearing portion of thrust bearing 6 and install it in bearing housing 15.
- 3) Apply Loctite on the threaded portion of M3 Torx T machine screw 17 for thrust bearing installation, and use Torx torque driver for installation by tightening to the specified torque.

Tightening torque: $1.3 \pm 0.1 \text{ N}\cdot\text{m}$ ($13 \pm 1 \text{ kgf}\cdot\text{cm}$)

(4) Seal plate installation

- 1) Fit the seal ring on oil thrower 2.
- 2) Insert oil thrower 2 into seal plate 4.

Note: The seal ring joint portion shall be positioned as illustrated at right.

- 3) Apply liquid gasket (Three Bond No.1207) on the seal plate mounting surface on the compressor side of bearing housing 15.

Note: See the illustration below for the applying position.

Applying thickness: $0.1 \sim 0.2 \text{ mm}$

- 4) Install seal plate 4 on bearing housing 15.
- 5) Apply Loctite on the threaded portion of M3 machine screw for seal plate mounting, and tighten it with a torque screwdriver.

Tightening torque: $1.3 \pm 0.1 \text{ N}\cdot\text{m}$ ($13 \pm 1 \text{ kgf}\cdot\text{cm}$)

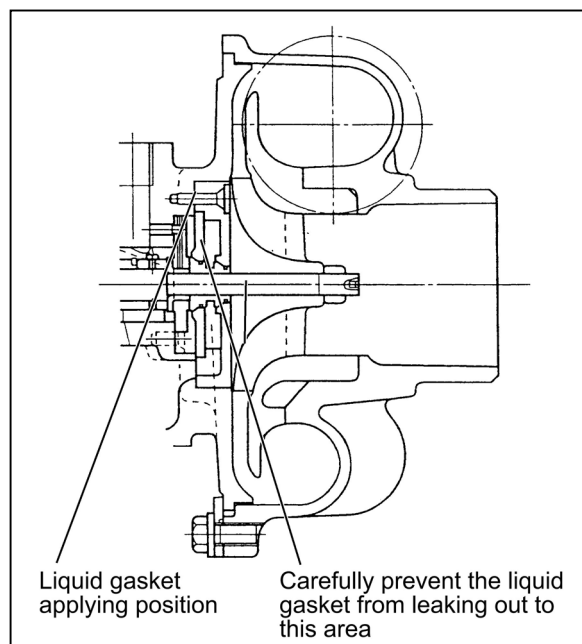
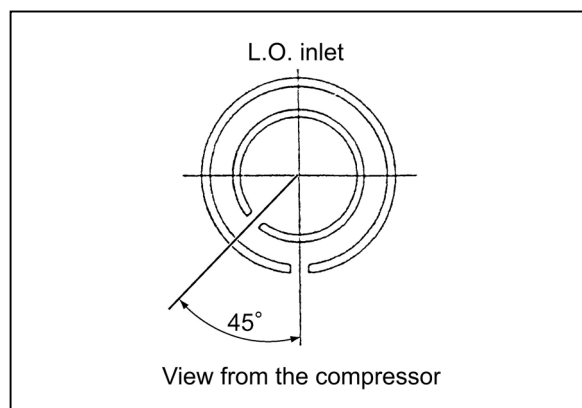

6) Yoke Assy.

7) Armature

Remove the brush holder. The armature and yoke assy can now be removed.

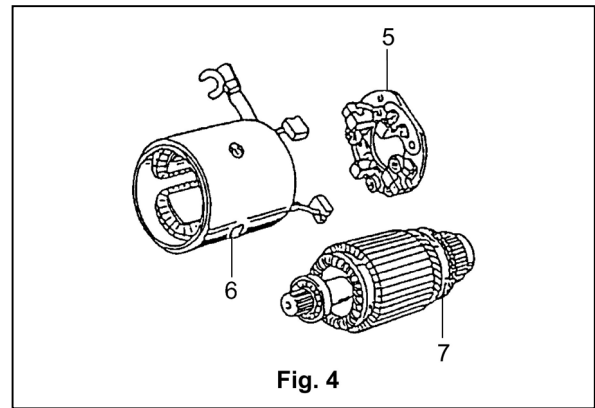

8) Bolt M6 (2)

9) Magnetic switch

Remove bolt M6 (10 mm), and the magnetic switch can be removed.

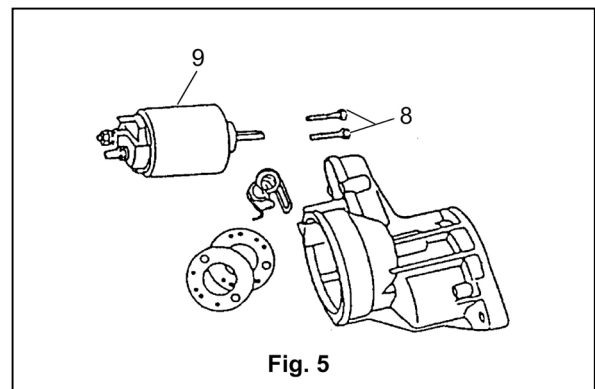

10) Dust cover

11) Shift lever

Take the dust cover out from the gear case. The shift lever can be removed.

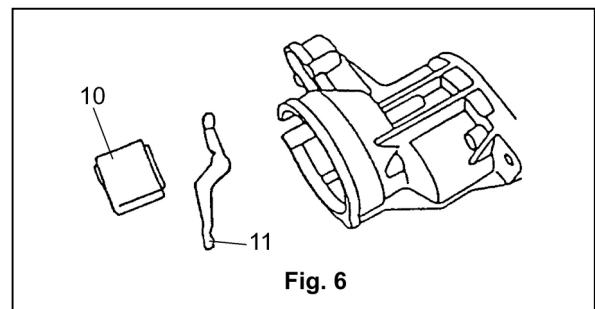

9.1.8 Characteristic test

Since the characteristics can be checked roughly by means of a simple no-load test as explained below.

NOTE: Complete the test quickly since the rating of the starting motor is 30 seconds.

(1) No-load test

Fix the starting motor on a test bench and connect wiring as shown in Fig.31. When the switch is closed, a current flows in the starting motor, which is rotated at no-load. Measure the current, voltage and number of revolutions then and check if they satisfy the specified characteristics.

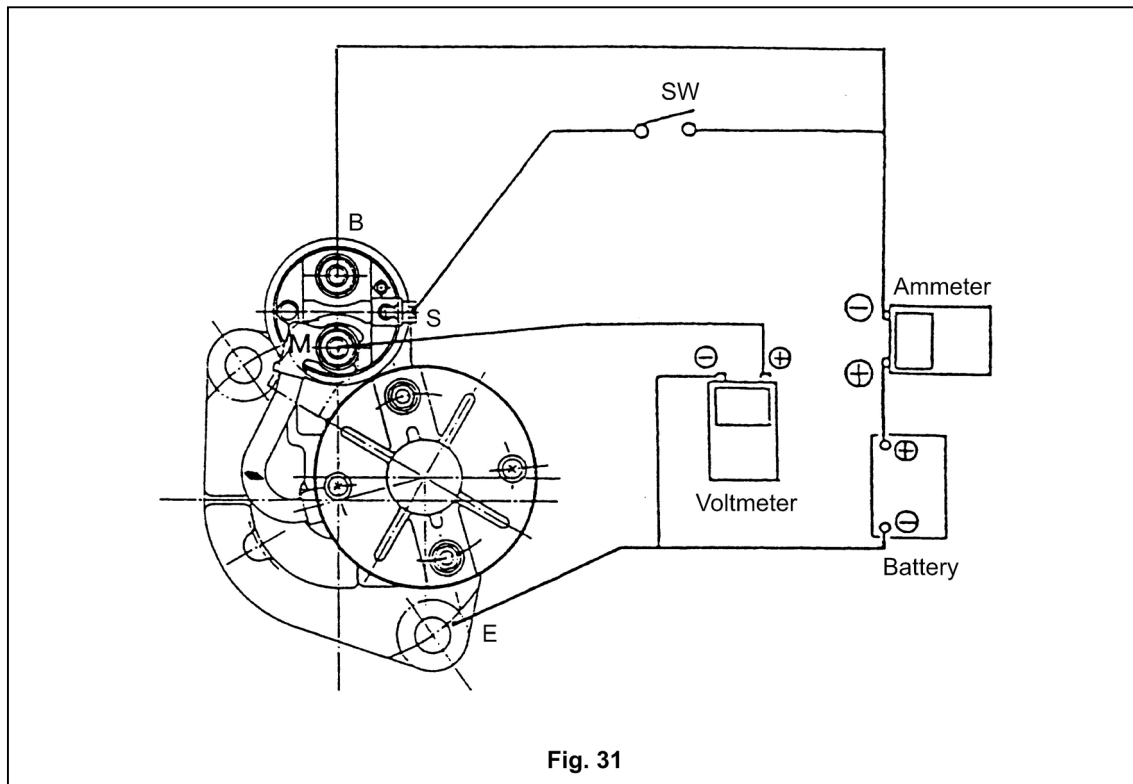

(7) Removal of gear case dust cover

Remove the two M5 bolts (using 4 mm hexagon wrench) to disassemble the dust cover from the gear case.

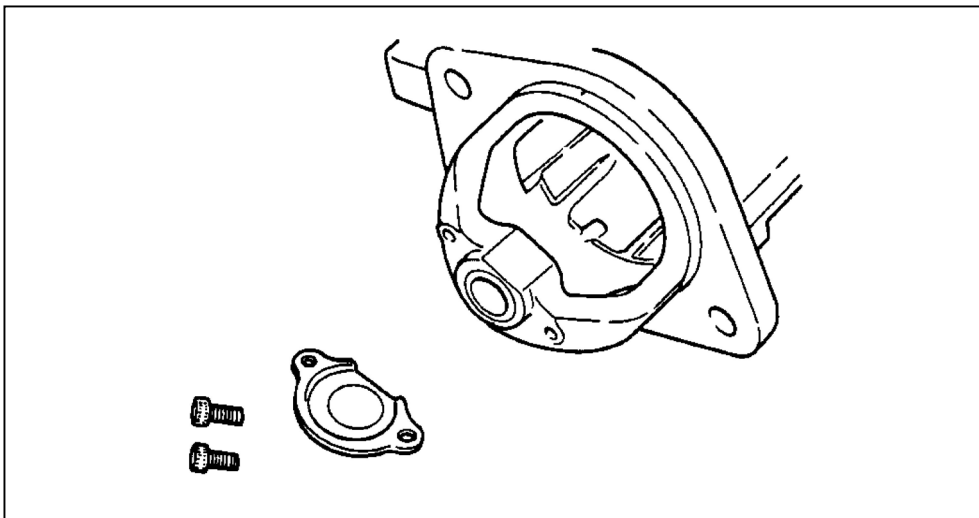
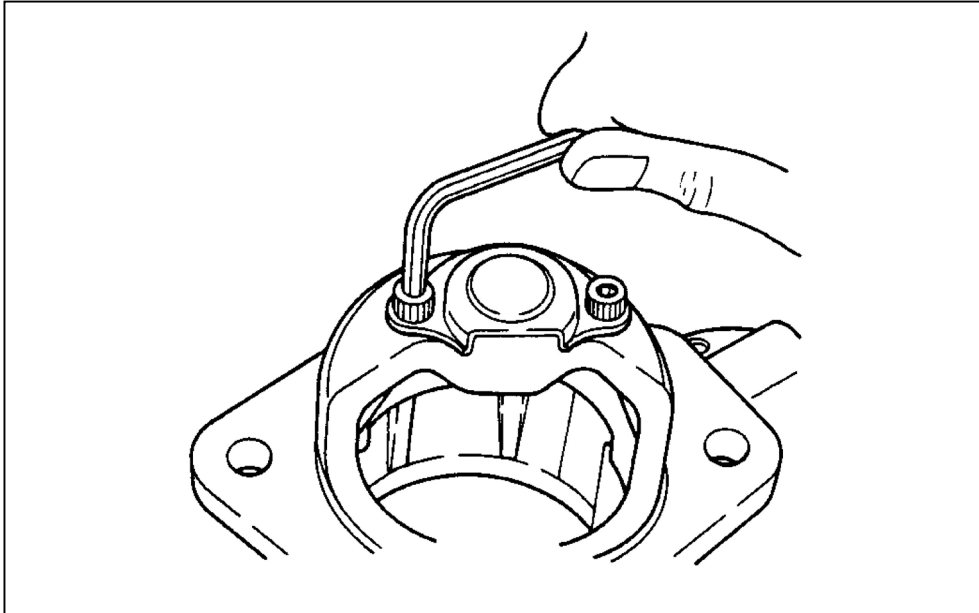

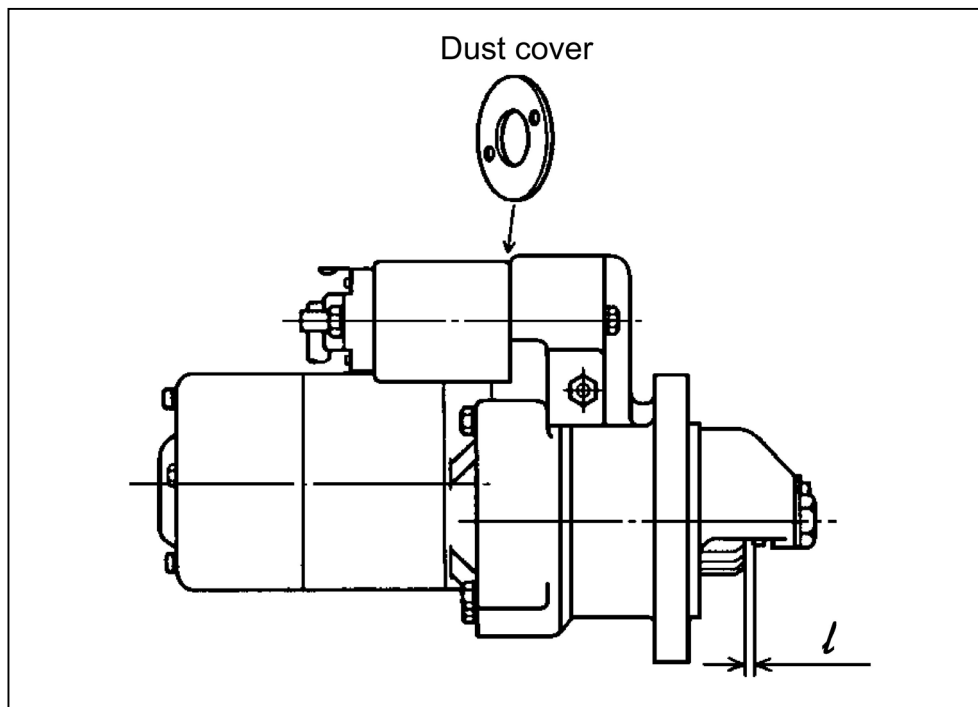

9.2.9 Service standards

Brush	Spring force N(kgf)		31.4 (3.2)
	Standard / Limit height		18/6
Commutator	Outside diameter	Standard	37
		Limit	36
	Deflection	Limit	0.2
		Correction accuracy	0.05
Depth of insulation mica	Limit	0.2	
	Correction accuracy	0.5~0.8	
Standard dimensions	Armature shaft diameter	Front	25
		Rear	12
	Bearing on gear case side	Gear shaft diameter	13.95~13.968
		Hole diameter	14.00~14.018
	Sliding portion of pinion	Shaft diameter	13.95~13.968
		Hole diameter	14.03~14.05
Ball bearing	Armature	Front	6905DDU
		Rear	6001DDU
Length L (pinion projection length)			0.3~1.5

12. SERVICE STANDARDS

12.1 Engine Tuning

No.	Inspection item		Standard		Limit	Reference page
1	Gap at intake/exhaust valve heads mm		TNV82A~98	0.15~0.25	-	2.2.6(4)
			4TNV106(T)	0.25~0.35	-	
2	V-belt tension mm at 98N (10kgf)	Between alternator and crank pulley	Used part	10~14	-	2.2.2.(2)
			New part	8~12	-	
		Between alternator and radiator fan	Used part	7~10		
			New part	5~8		
Between radiator fan and crank pulley	Used part	9~13				
	New part	7~11				
3	Fuel injection pressure MPa (kgf/cm ²)	3TNV82A~TNV88(VM) 4TNV94L~106(T)	21.57~22.55 (220~230)	-	2.2.6.(3)	
		3TNV82A~TNV88(CL)	19.6~20.6 (200~210)			
4	Compression pressure (at 250 min ⁻¹) MPa (kgf/cm ²)	TNV82A	3.16(31)±0.1(1)	2.45(25)±0.1(1)	3.3	
		TNV84	3.24(33)±0.1(1)	2.55(26)±0.1(1)		
		3/4TNV84T	2.94(30)±0.1(1)	2.45(25)±0.1(1)		
		TNV88-106	3.43(35)±0.1(1)	2.75(28)±0.1(1)		
5	Coolant water Capacity (Only engine body) (Liter)	3TNV82A,84	1.8	-	2.2.1.(4)	
		3TNV84T,88	2.0	-		
		4TNV84(T),88	2.7	-		
		4TNV94L·98(T)	4.2	-		
		4TNV106(T)	6.0	-		
6	Lubricating oil capacity (oil pan) (Liter)	-	Full	Effective	-	2.2.1.(3)
		3TNV82A	5.5	1.9	-	
		3TNV84(T)/88	6.7	2.8	-	
		4TNV84(T)/88	7.4	3.4	-	
		4TNV94L/98(T)	10.5	4.5	-	
		4TNV106(T) (CL class)	14.0	9.0	-	
		4TNV106(T) (VM class)	14.0	7.5	-	
7	Lubricating oil pressure MPa (kgf/cm ²)	-	at rated speed		at low idle speed	-
		3TNV82A~98	0.29(3.0)~0.39(4.0)		0.06(0.6) or above	-
		4TNV98T 4TNV106(T) (VM, WO balancer)	0.39(4.0)~0.49(5.0)			
		4TNV106(T) (CL, WO balancer)	0.31(3.2)~0.49(5.0)			
		4TNV106(T) (VM, W balancer)	0.34(3.5)~0.44(4.5)			
8	Oil pressure switch operating pressure MPa (kgf/cm ²)	0.05±0.01 (0.5±0.1)		-	-	
9	Thermostat		valve opening temperature deg. C	Full opening lift (mm) (temperature)	2.7	
		All models	69.5~72.5	8 or above (85 deg.C)		
		All models option	80~84	10 or above (95 deg.C)		
10	Thermo switch actuating temperature (deg.C)	107~113		-	2.4.2	

12.3 Lubricating Oil System (Trochoid Pump)

(1) Outside clearance of outer rotor

mm			
Model	Standard	Limit	Reference page
3TNV82A~88	0.12~0.21	0.30	5.5.1(1)
4TNV94L/98	0.100~0.155	0.25	
4TNV106(T)	0.100~0.165	0.25	

(2) Side clearance of outer rotor

mm			
Model	Standard	Limit	Reference page
3TNV82A~88	0.02~0.07	0.12	5.5.1(1)
4TNV94L/98	0.05~0.10	0.15	
4TNV106(T)	0.03~0.12	0.17	

(3) Inside clearance of inner rotor

mm					
Item	Parts	Standard	Standard	Limit	Reference page
Inside clearance of inner rotor	Gear boss diameter	53.05~53.15	0.3~0.5	0.6	5.5.1 (2)
	Rotor diameter	53.45~53.55			
Width across flat clearance of inner rotor	Width across flat of Gear boss	49.45~49.75	0.2~0.6	0.7	
	Width across flat of rotor	49.95~50.05			

(4) Rotor shaft clearance

mm				
Model	Inspection item	Standard	Limit	Reference page
4TNV94L/ 98	Gear case bearing I.D.	12.980~13.02	13.05	5.5.1(3)
	Rotor shaft O.D.	12.955~12.975	12.945	
	Rotor clearance	0.035~0.065	0.105	
4TNV106(T)	Gear case bearing I.D.	13.00~13.02	13.05	
	Rotor shaft O.D.	12.955~12.965	12.945	
	Rotor clearance	0.035~0.065	0.105	

CAUTION



- Wears for safe operation
Wear a helmet, working clothes, safety shoes and other safety protectors suited to the job. It is especially important to wear well-fitting work clothes.
Failure to observe
A serious accident such as trapping by a machine may occur.

WARNING

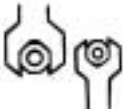

- Use of appropriate tools
Use tools appropriate for the jobs to be done. Use a correctly sized tool for loosening or tightening a machine part.
Failure to observe
A serious injury or engine damage may occur.

CAUTION



- Always use genuine parts
Jobs such as engine running part welding and polishing the paint with sandpaper should be done in a well-ventilated place.
Failure to Observe
Shortening of MP pump unit life or an unexpected accident may arise.

WARNING



- Always tighten to the specified torque if designated in the manual.
Failure to Observe
Loosening or falling may cause parts damage or injury.

CAUTION

Observe the following instructions with regard to waste disposal.

Negligence of each instruction will cause environmental pollution.

- Waste fluids such as engine oil and cooling water shall be discharged into a container without spillage onto the ground
- Do not let waste fluids be discharged into the sewerage, a river or the sea.
- Harmful wastes such as oil, fuel, solvents, filter elements and battery shall be treated according to the respective laws and regulations. Ask a qualified collecting company for example.

(4) Max speed

The angle of the control lever is set at determined engine speed. The governor keeps engine speed constant by adjusting speed when load changes. For example, if the operator moves the control lever with the link from the idling position to max. Output, governor spring tension increases, the tension lever is pulled until it comes in contact with the full load stopper, the movement of the governor lever is transmitted to the control rack via the link, maintaining the full load rack position, and engine speed increase until the governor weight thrust load and governor spring tension come into equilibrium at full load max. Speed.

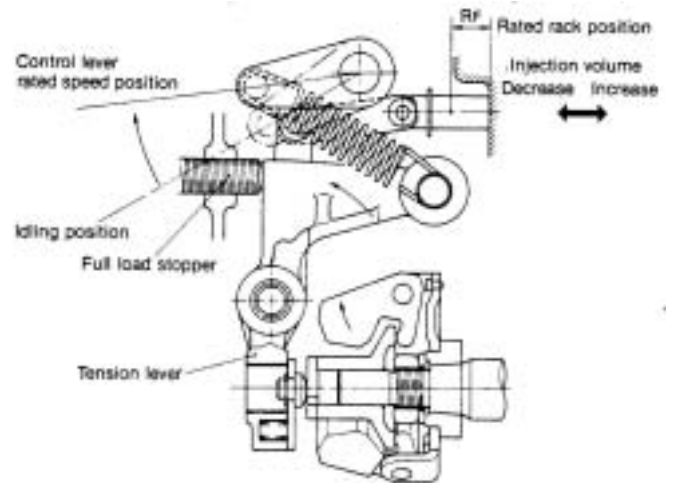

(5) Necessity and function of angleich

The governor must satisfy the required injection curves represented in the diagram below in order to obtain sufficient output at low speed, and not emit black smoke at high speed. the angleich spring was devised to provide for maximum torque at low speed by setting injection volume at point A, and shifting injection volume to point B' at high engine speed.

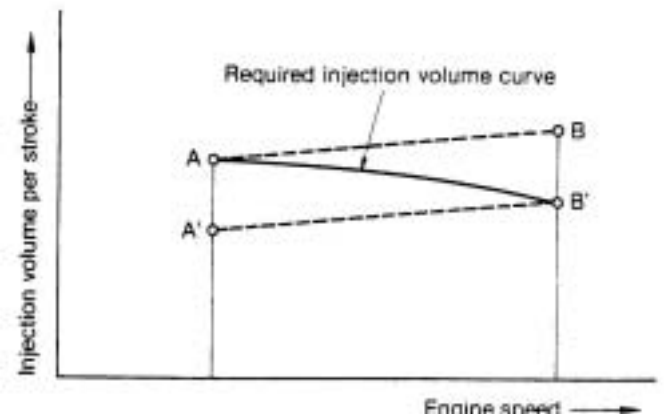

3.1.2. Separating the governor weight CMP



Providing whirl-stop to the camshaft



Example of whirl-stop



Remove the nut, (governor support).

3.1.3. Disassembling the hydraulic head

Disassembling the hydraulic head



Remove the joint, (FO inlet pipe).

Disassembling the delivery valve



Remove the holder, (delivery).



Remove the delivery valve and gasket.



Delivery valve parts disassembled. (Take care not to mix these with other parts on reassembly. Reassemble these to the original port as a set.)



Remove the delivery valve and gasket.
Remove gasket

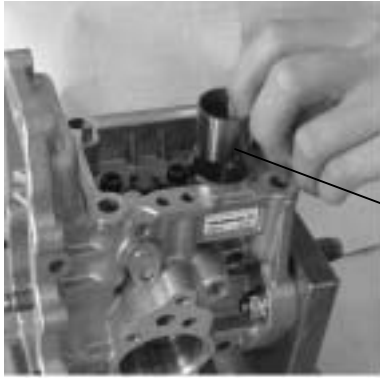

Whirl-stop groove

Install the tappet.

Direct the tappet's whirl-stop groove as shown in the illustration.

Assembling tappets

- Insert tappet into the pump body with the slit directed toward the lock side, and attach the tappet lock. (T = 4 to 5 N·m)
- Turn the camshaft to check that the tappet moves up and down smoothly.



Install the whirl-stop, (tappet).

Tighten the tappet, while moving it upward and downward.



Install the governor weight CMP and nut, (governor support).



Fasten the nut, (governor support), (and provide the whirl-stop to the cam shaft.)

Tightening Torque : 79 - 84 N·m



Install the feed pump.



Identification hole (ϕ 3, depth 2 mm)

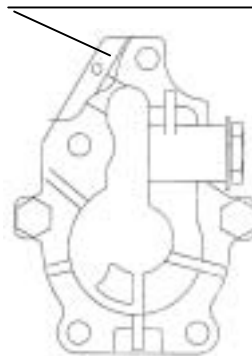

Identification of feed pump

Spec.	ϕ 3 identification hole
General purpose	Not provided
TK	Provided

Note that the identification hole can be seen only when looking from obliquely above because it is located on the pump case side.

- (4) Remove the plug in the oil fill hole on the top of the governor case, and fill the pump with about 200cc of pump oil or engine oil.



- (5) Complete fuel oil piping and operate the pump tester to purge the line of air.
- (6) Set the pressure of oil fed from pump tester to injection pump at $19.6-29.4\text{kPa}(0.2-0.3\text{kgf/cm}^2)$,temp. at $40 \pm 2 \text{ degC}(104 \pm 3.6 \text{ degF})$

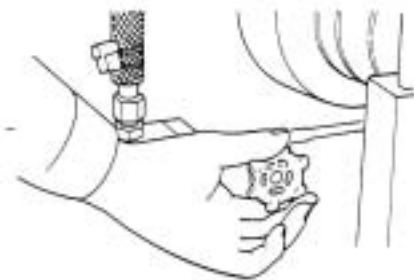

5.5. Fuel injection nozzle reassembly

The fuel injection nozzle is reassembled in the opposite order to disassembly.

- (1) Insert the adjusting shims, nozzle spring and nozzle spring seat in the nozzle holder, mount the stop plate with the pin and insert the nozzle body/nozzle set and tighten the nut.
- (2) Use the special holder when tightening the nut for the hole type nozzle as in disassembly.

Nozzle nut tightening torque

	N-m(kgf-m)
Hole type nozzle	39 – 44 (4 – 5)

5.6. Adjusting fuel injection nozzle

5.6.1. Adjusting opening pressure

Mount the fuel injection nozzle on the nozzle tester and use the handle to measure injection starting pressure. If it is not at specified pressure, use the adjusting shims to increase/decrease pressure (both hole and pintle types).

Adjusting by 0.1 mm results in a change in the injection starting pressure of about 2 Mpa (20 kgf / cm²)

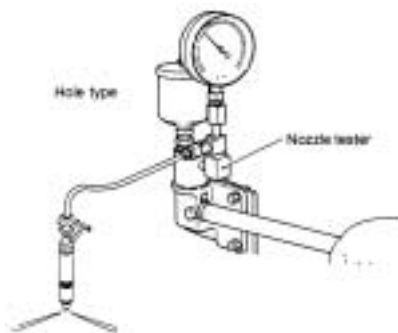

Injection starting pressure

	MPa(kgf/cm ²)
Injection starting pressure	19.6 - 20.6 (200 – 210)
	21.6 – 22.6 (220 – 230)

Remark) Injection starting pressure changes on engine specifications.

CLICK HERE TO **DOWNLOAD** THE COMPLETE MANUAL

- Thank you very much for reading the preview of the manual.
- You can download the complete manual from: www.heydownloads.com by clicking the link below



- Please note: If there is no response to CLICKING the link, please download this PDF first and then click on it.

CLICK HERE TO **DOWNLOAD** THE COMPLETE MANUAL