

Shop Manual

ENGINE

140E -7 SERIES

KOMATSU

CLICK HERE TO **DOWNLOAD** THE COMPLETE MANUAL

- Thank you very much for reading the preview of the manual.
- You can download the complete manual from: www.heydownloads.com by clicking the link below



- Please note: If there is no response to CLICKING the link, please download this PDF first and then click on it.

CLICK HERE TO **DOWNLOAD** THE COMPLETE MANUAL

Abbreviation	Actual word spelled out
S/T	Steering
STRG	
SIG	Signal
SOL	Solenoid
STD	Standard
OPT	Option
OP	
PRESS	Pressure
SPEC	Specification
SW	Switch
TEMP	Temperature
T/C	Torque Converter
T/M	Transmission

REMARK

- The figure shows an example of fitting of O-ring.
- An O-ring is fitted to every joint of the air conditioner piping.

For tightening torques, see THE OTHER INFORMATION, "Precautions for disconnection and connection of air conditioner piping".

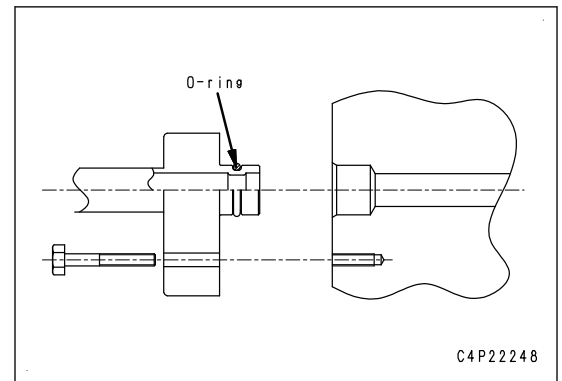
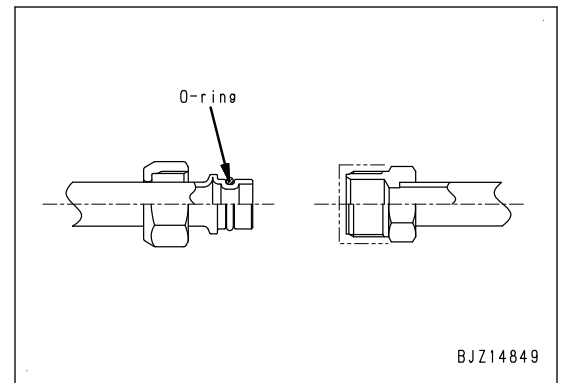

REMARK

The oil cleaning equipment can remove the ultra fine (approximately 3 μm) particles that the filter built in the hydraulic equipment cannot remove. So, it is very effective device.

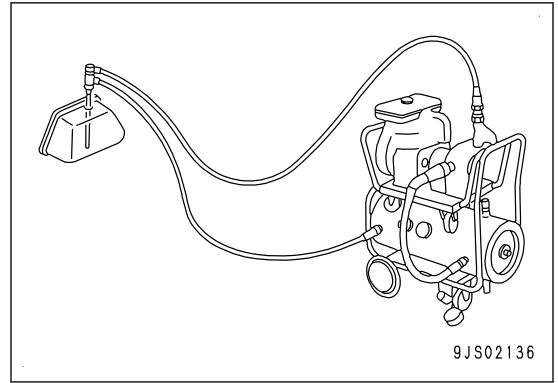

PRECAUTIONS FOR HANDLING FUEL SYSTEM EQUIPMENT

The machines equipped with common rail fuel injection system (CRI) consists of more precise parts than the parts used in the conventional fuel injection pump and nozzle. If foreign material enters this system, it may cause a failure. Use special care to prevent entry of the foreign material when servicing the fuel system.

Select an appropriate workplace

Avoid the work of adding hydraulic oil, replacing filters, or repairing the machine in rainy or windy weather, or in dusty environment.

Sealing the opening

Plug the removed pipes and the openings of the removed components with the caps, tapes, plastic bags, etc. to prevent foreign material from entering.

NOTICE

Do not expose the openings or stuff it, otherwise foreign material may enter or leaked oil may pollute the environment.

Do not discard the oil inconsiderately. Ask the customer for disposal or bring it back to dispose it appropriately.

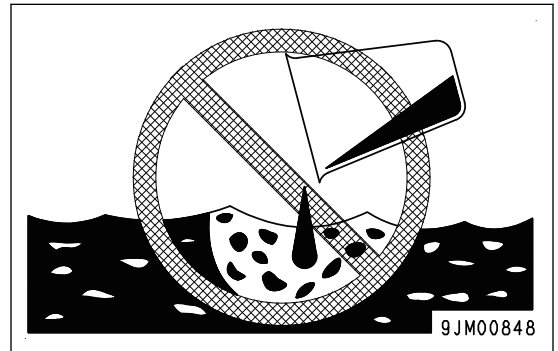

How to clean parts when dirt is stuck

If any dirt or dust sticks the parts of the fuel system, clean it off thoroughly with clean fuel.

Precautions for replacing fuel filter cartridge

Be sure to use the Komatsu genuine fuel filter cartridge.

NOTICE

The machine equipped with common rail fuel injection system (CRI) consists of more precise parts than the parts used in the conventional fuel injection pump and nozzle. In order to prevent foreign material from entering this system, the filter employs a specially high performance of filter element. If a filter other than a Komatsu genuine filter is used, fuel system contamination and damage may occur. Therefore Komatsu recommends using only Komatsu fuel filters and install them following the procedures in the shop manual.

METHOD FOR DISCONNECTING AND CONNECTING DEUTSCH CONNECTOR

Method for disconnecting Deutsch connector

While pressing locks (a) and (b) from each side respectively, pull out female connector (2).

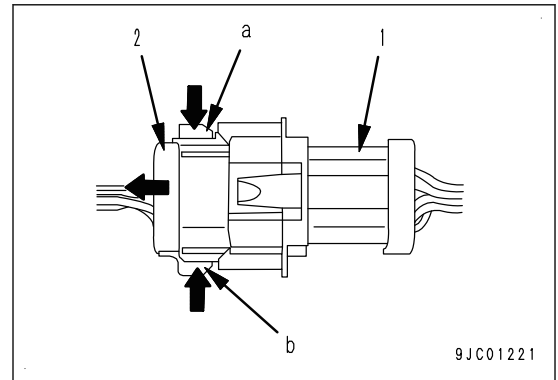

Method for connecting Deutsch connector

1. Push in female connector (2) horizontally, and insert it straight until it clicks. (Arrow: x)
2. In order to check whether locks (a) and (b) are completely inserted, insert female connector (2) by rocking it vertically (in the arrow z direction). (Arrow: x, y, z)

REMARK

Lock (a) in the figure is pulled down (not set completely), and lock (b) is set completely.

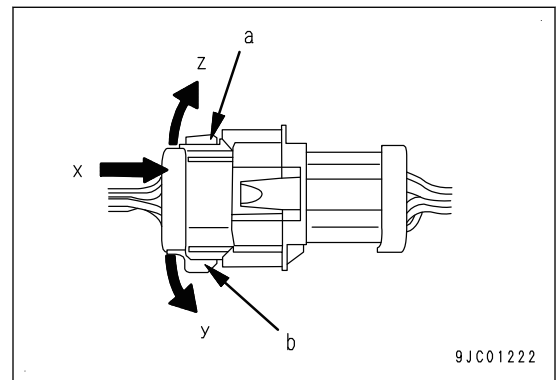

Types of circuits and color codes

Type of wire		AVS, AV, CAVS						AEX	
Type of circuit	Charge	R	WG	-	-	-	-	R	-
	Ground	B	-	-	-	-	-	B	-
	Start	R	-	-	-	-	-	R	-
	Light	RW	RB	RY	RG	RL	-	O	-
	Instrument	Y	YR	YB	YG	YL	YW	Y	Gr
	Signal	G	GW	GR	GY	GB	GL	G	Br
	Others	L	LW	LR	LY	LB	-	L	-
		Br	BrW	BrR	BrY	BrB	-	-	-
		Lg	LgR	LgY	LgB	LgW	-	-	-
		O	-	-	-	-	-	-	-
		Gr	-	-	-	-	-	-	-
		P	-	-	-	-	-	-	-
		Sb	-	-	-	-	-	-	-
Dg		-	-	-	-	-	-	-	
Ch	-	-	-	-	-	-	-		

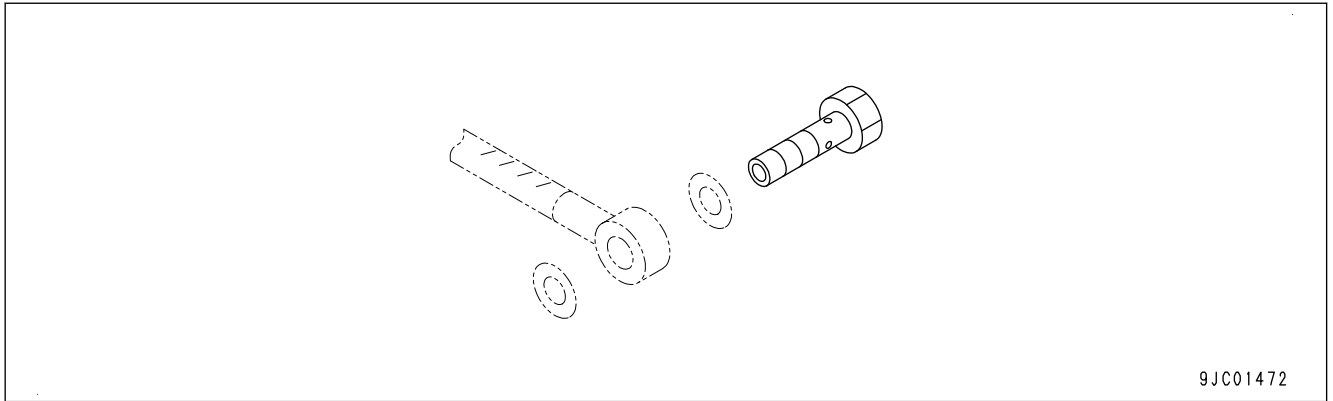

Thread diameter (mm)	Tightening torque (Nm { kgm })
6	8±2 {0.81±0.20}
8	10±2 {1.02±0.20}
10	12±2 {1.22±0.20}
12	24±4 {2.45±0.41}
14	36±5 {3.67±0.51}

Tightening torque table for tapered screws on 102, 107, and 114 series engines (National taper pipe thread (NPT))

REMARK

Tighten the National taper pipe threaded (NPT) screws used on the 102, 107, and 114 series engines to the torques shown in the following table unless otherwise specified.

Material of female screw	In cast iron or steel	In aluminum
Nominal thread size	Tightening torque (Nm { kgm })	Tightening torque (Nm { kgm })
$1/16$	15±2 {1.53±0.20}	5±1 {0.51±0.10}
$1/8$	20±2 {2.04±0.20}	15±2 {1.53±0.20}
$1/4$	25±3 {2.55±0.31}	20±2 {2.04±0.20}
$3/8$	35±4 {3.57±0.41}	25±3 {2.55±0.31}
$1/2$	55±6 {5.61±0.61}	35±4 {3.57±0.41}
$3/4$	75±8 {7.65±0.82}	45±5 {4.59±0.51}

Abbreviation	Actual word spelled out	Purpose of use (major applicable machine (*1), or component/system)	Explanation
ICT	Information and Communication Technology	Communication and electronic control	A general term for the engineering and its socially applied technology of information processing and communication.
IMA	Inlet Metering Actuator	Engine	This is a valve that adjusts the fuel intake amount at the pump inlet in order to control the supply pump fuel discharged volume. (Same as IMV)
IMU	Inertial Measurement Unit	Engine	This is a device to detect the angle (or angular velocity) and acceleration of the 3 axes that control motions.
IMV	Inlet Metering Valve	Engine	This is a valve that adjusts the fuel intake amount at the pump inlet in order to control the supply pump combustion discharged volume. (Same as IMA)
KCCV	Komatsu Closed Crankcase Ventilation	Engine	This is a mechanism that burns the blowby gas again by separating oil from blowby gas and returning it to the intake side. It primarily consists of filters.
KCSF	Komatsu Catalyzed Soot Filter	Engine	This is a filter that captures soot in exhaust gas. It is built in to KDPF.
KDOC	Komatsu Diesel Oxidation Catalyst	Engine	This is a catalyst that is used for purifying exhaust gas. It is built in to KDPF or assembled with the muffler.
KDPF	Komatsu Diesel Particulate Filter	Engine	This is a component that is used to purify the exhaust gas. KDOC (catalyst) and KCSF (filter to capture soot) are built-in it. It is installed instead of the conventional muffler.
KTCS	Komatsu Traction Control System	Travel and brake (HM)	This is a function that performs braking with the optimum force and recovers the driving force of the wheels by actuating the inter-axle differential lock when the wheels runs idle while the machine travels on the soft ground.
LCD	Liquid Crystal Display	Machine monitor	This is an image display equipment such as a monitor in which the liquid crystal elements are assembled.
LED	Light Emitting Diode	Electronic parts	This is a semiconductor element that emits light when the voltage is applied in forward direction.
LIN	Local Interconnect Network	Communication and electronic control	This is one of communication standards that are used in the network on the machine.
LS	Load Sensing	Hydraulic system	This is a function that detects differential pressure of pump, and controls discharged volume corresponding to load.
LVDS	Low Voltage Differential Signaling	Communication and electronic control	This is one of communication standards that are used in the network on the machine.
MAF	Mass Air Flow	Engine	This indicates engine intake air flow. This is not used independently but is used as combined with sensor. Mass air flow sensor can be called as MAF sensor.

SPECIFICATIONS: SAA6D140E-7 (HM400-5, HM400-5E0)

Engine model		SAA6D140E-7	
No. of cylinders - bore x stroke		mm	6-140x165
Piston displacement		ℓ{ cc}	15.2 {15230}
Firing order		–	1-5-3-6-2-4
Dimensions	Overall length	mm	1634
	Overall width	mm	1091
	Overall height (excluding KDPF/SCR)	mm	1527
	Overall height (including KDPF/SCR)	mm	-
Performance	Rated horsepower	kW{ HP}/ min ⁻¹ { rpm}	353±10.5 {473±14.1}/2000 {2000}
	Max. torque	Nm{ kgm}/ min ⁻¹ { rpm}	2275±68.0 {232±6.9}/1400{1400}
	Max. speed with no load (high idle speed)	min ⁻¹ { rpm}	2200 (+50/0) {2200 (+50/0)}
	Min. speed with no load (low idle speed)	min ⁻¹ { rpm}	725±25 {725±25}
	Fuel consumption ratio at rated point	g/kWh{ g/HPh}	213 {159}
Dry weight		kg	1890
Fuel injection system		–	High-pressure common rail type
Control of fuel injection system		–	Electronic control type
Lubricating oil amount (Refill capacity)		ℓ	58 (50)
Amount of coolant		ℓ	27 (only engine)
Alternator		–	24 V, 90 A or 140 A
Starting motor		–	24 V, 11 kW
Turbocharger		–	KOMATSU, Model KTR95V

Rear view

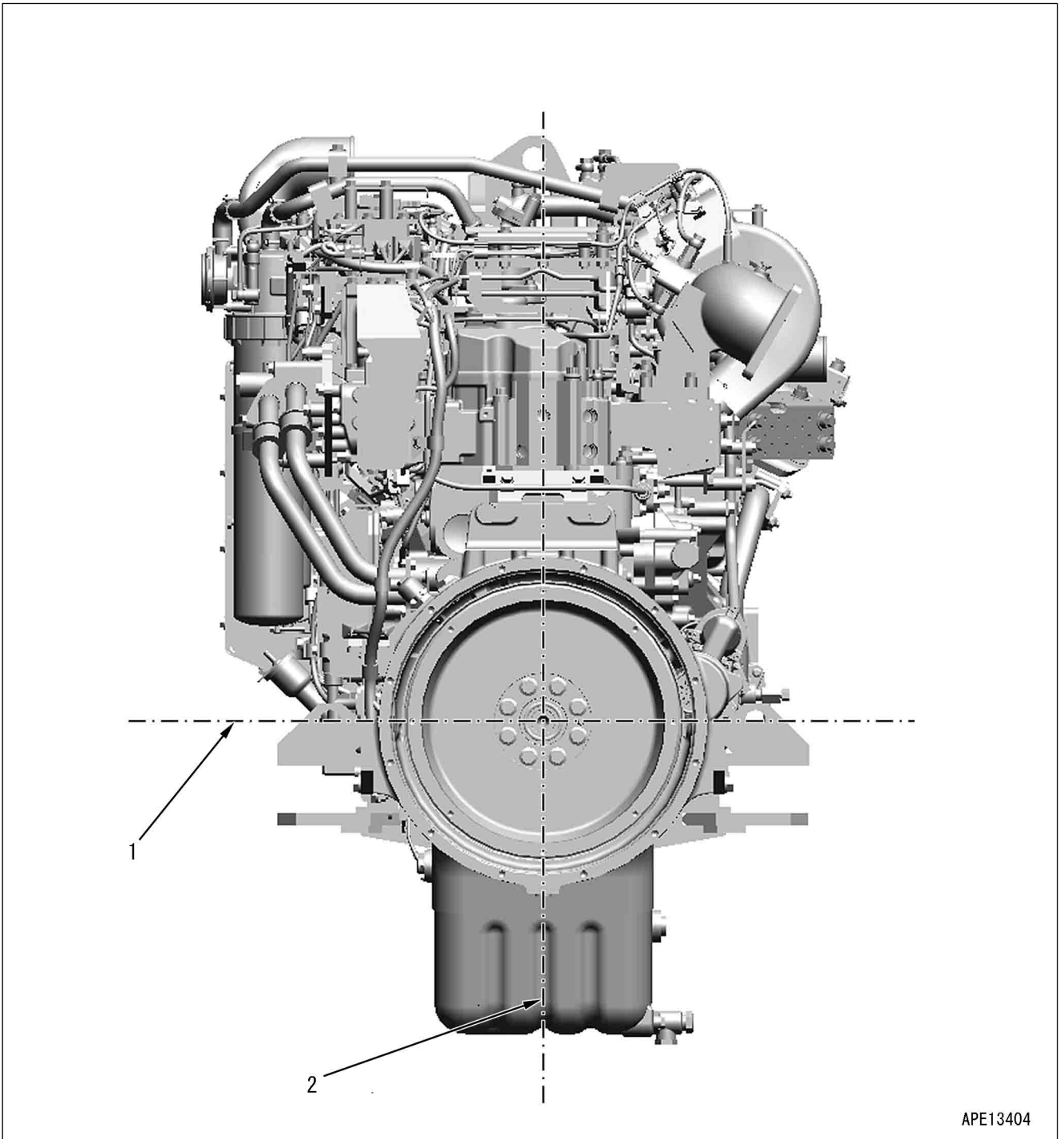

APE13404

1: Center of crankshaft

2: Center of cylinder

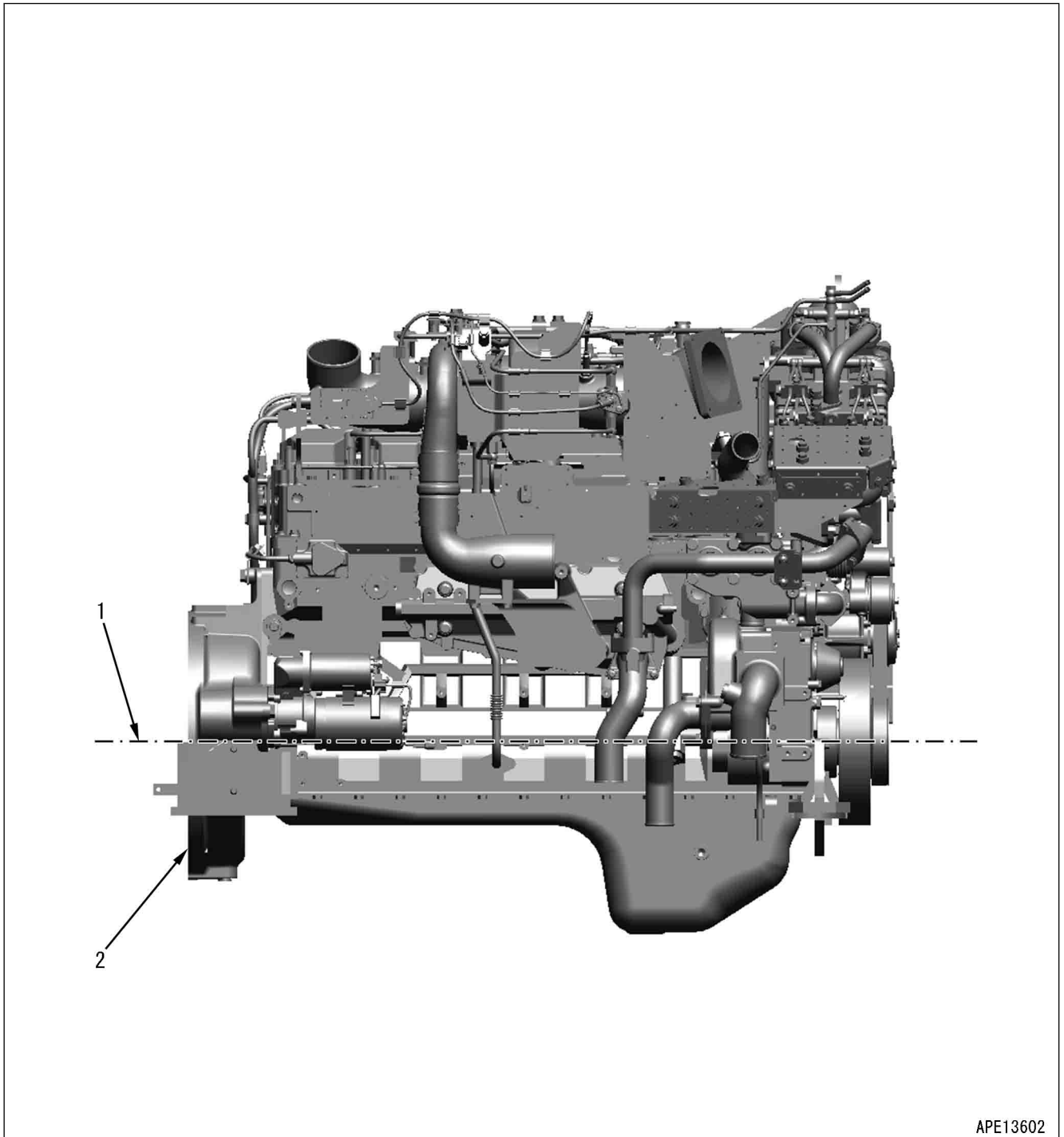







Right side view

APE13602

1: Center of crankshaft

2: Rear face of flywheel housing

10 STRUCTURE AND FUNCTION

Status	Elapsed time (*1)	Machine monitor					Engine de-ration (*5)
		Message of SCR Infor-mation	Caution lamp (Action lev-el)	Tone of au-dible alert	Failure code for abnormali-ty (*2),(*3)	Failure code for Induce-ment strategy status (*4)	
1 Warning	1 hour	1: Please inspect and maintain SCR sys-tem.	Red  APP14418 Red  APP14414	Long inter-mittently	CA4151 CB4151	No indication	Torque: over 25%
2 Escalated Warning (Warning 2)	2 hours	2: Without treatment, engine power will be derated.	Red  APP14418 Yellow  APP14417 Red  APP14414	Triplet (*6) Short inter-mittently (*7)	CA4151 CB4151	AS00R2 (Warning 2 (SCR Device Abnormality))	Torque: over 25%
3 Mild In-ducement (Induce-ment 1)	3 hours	3: Engine power is under dera-tion.	Red  APP14418 Red  APP14415 Red  APP14414	Long inter-mittently	CA4151 CB4151	AS00R3 (Inducement 1 (SCR De-vice Abnor-mality))	Torque: over 25%

COMPONENT PARTS OF UREA SCR SYSTEM

SCR

Abbreviation for Selective Catalytic Reduction

AdBlue/DEF MIXING TUBE

STRUCTURE OF AdBlue/DEF MIXING TUBE

REMARK

The shape is subject to machine models.

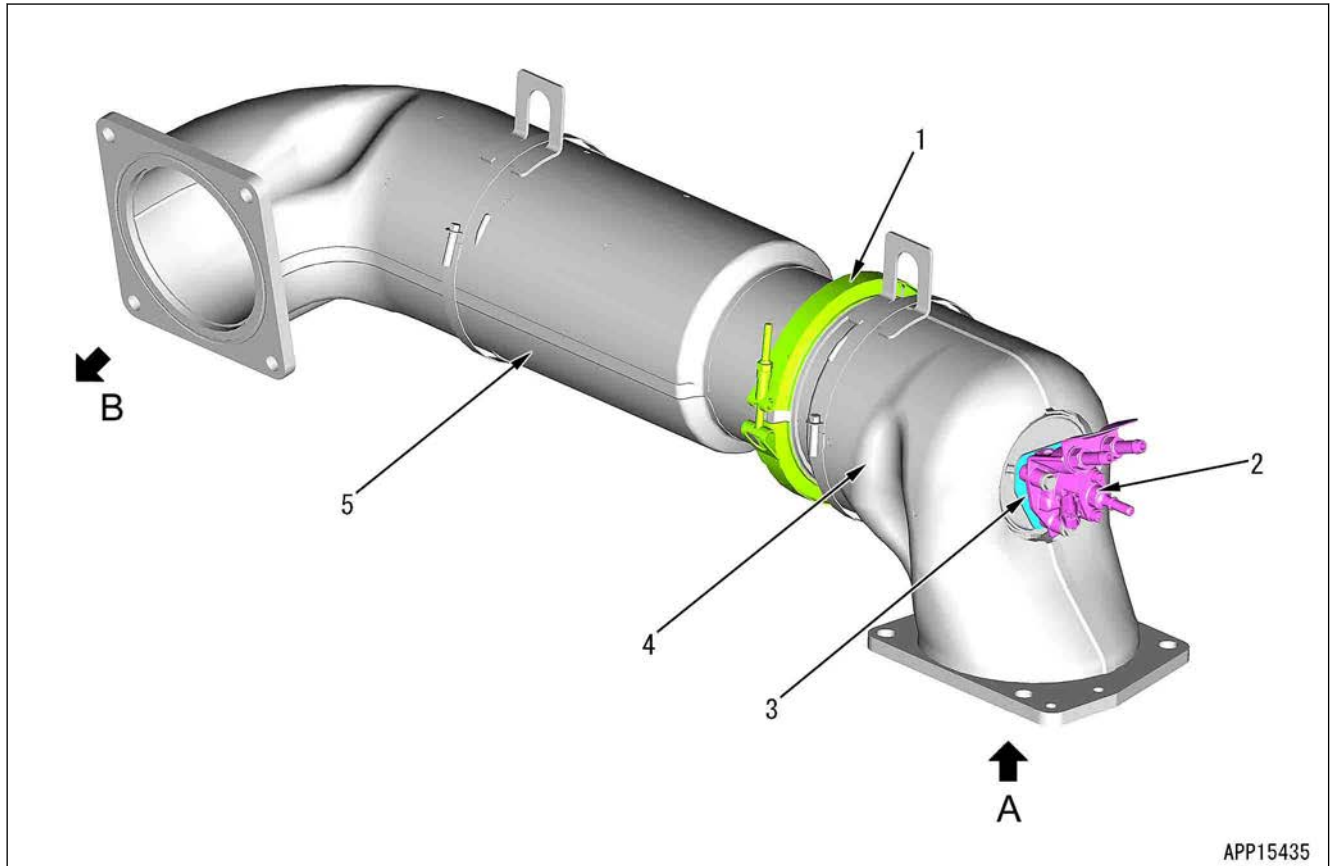

A: Exhaust gas inlet (from KDPF)

B: Exhaust gas outlet (to SCR)

1: V clamp

4: AdBlue/DEF mixing tube (connector)

2: AdBlue/DEF injector

5: AdBlue/DEF mixing tube (tube)

3: Gasket for AdBlue/DEF injector

FUNCTION OF AdBlue/DEF MIXING TUBE

It mixes AdBlue/DEF injected from AdBlue/DEF injector with exhaust gas, and decomposes it to ammonia which is needed to purge NOx from SCR assembly.

23: Crankshaft pulley

General view

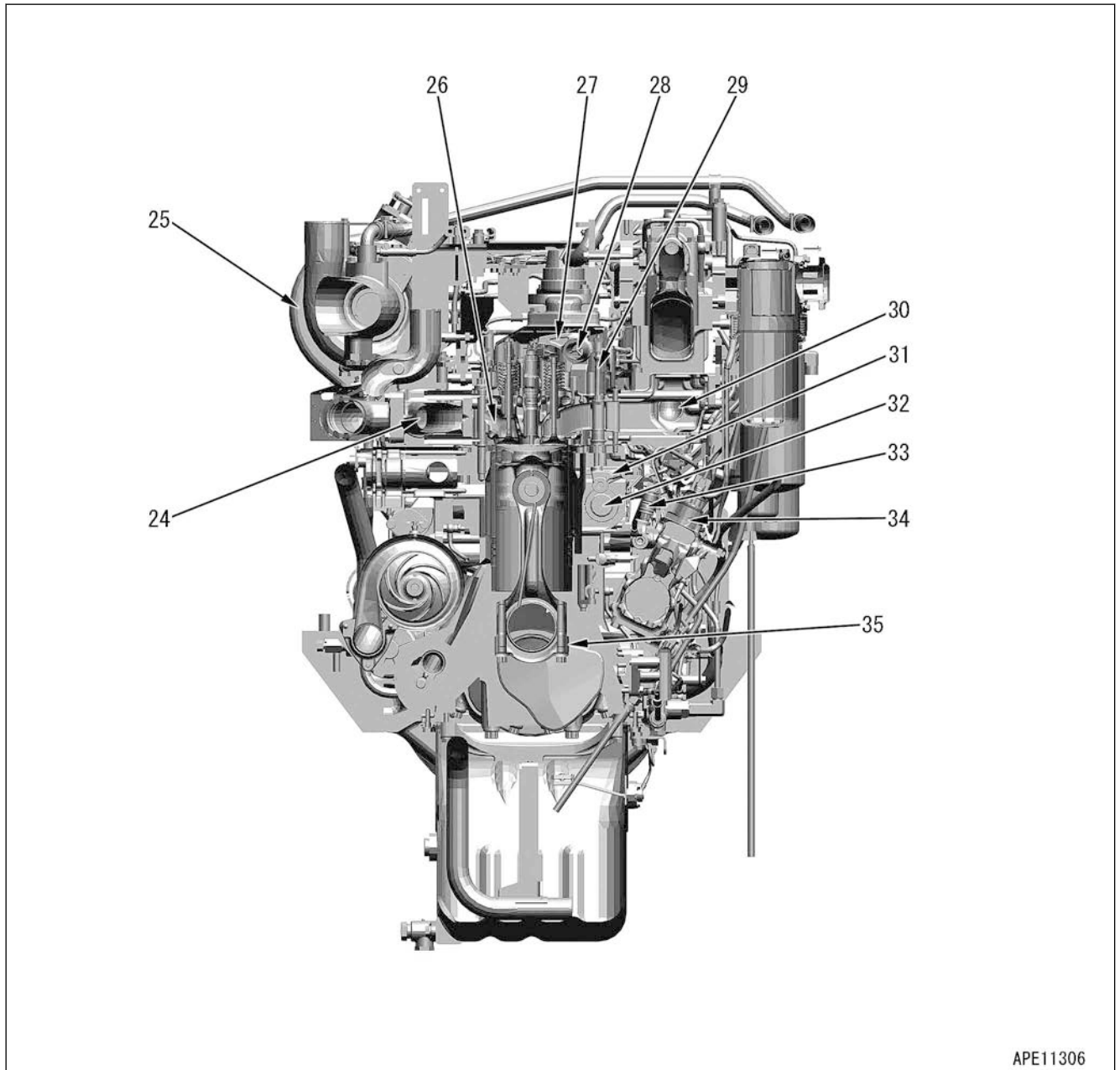

APE11306

24: Exhaust manifold
 25: Turbocharger
 26: Cylinder head
 27: Rocker arm
 28: Rocker arm shaft
 29: Push rod
 30: Intake manifold

31: Cam follower
 32: Camshaft
 33: Common rail
 34: Supply pump
 35: Connecting rod cap

MAIN MOVING PARTS

STRUCTURE OF MAIN MOVING PARTS

REMARK

The shape is subject to machine models.

Sectional view

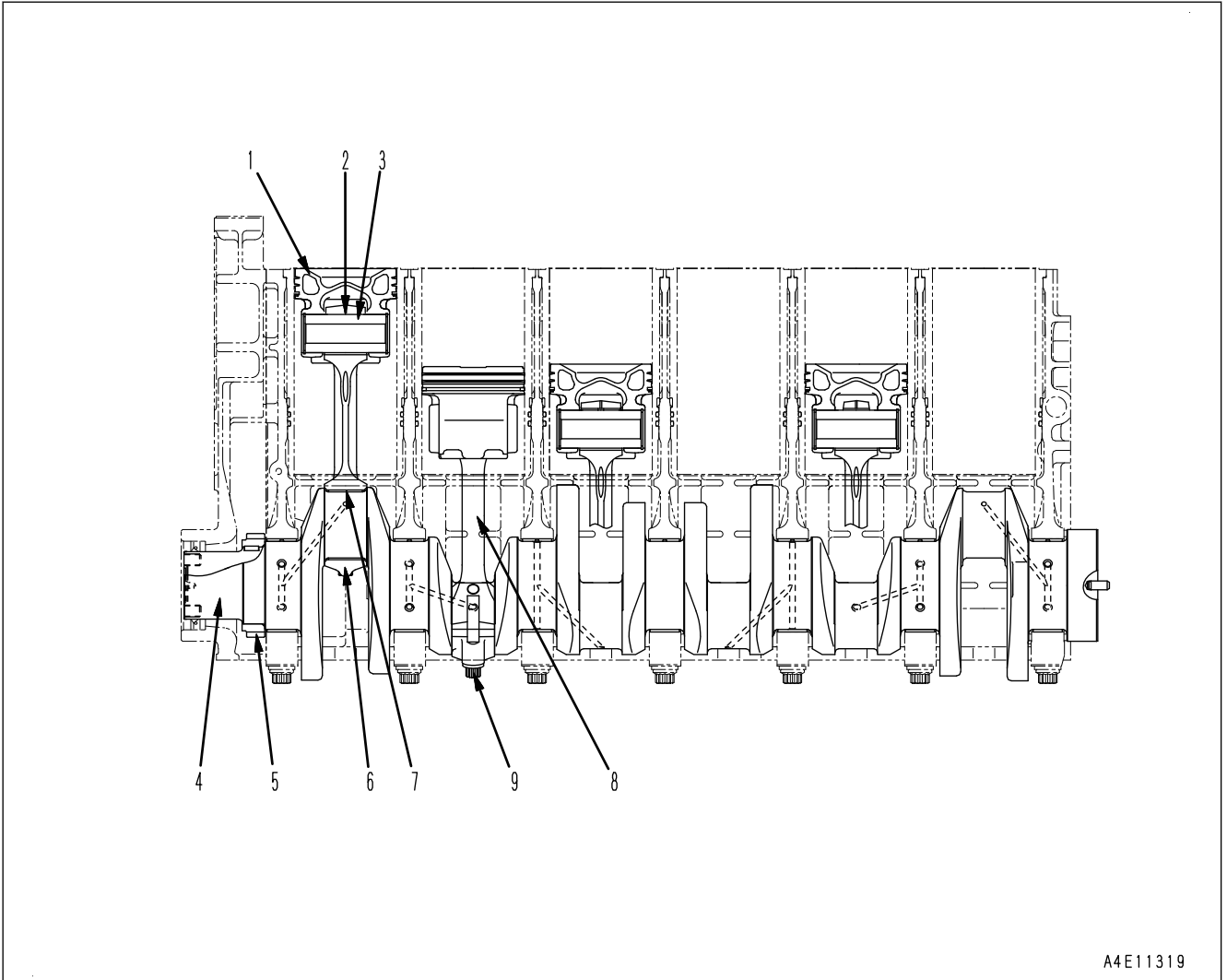

A4E11319

1: Piston (FCD piston)

2: Connecting rod bushing

3: Piston pin

4: Crankshaft

5: Crankshaft gear (number teeth: 36)

6: Connecting rod cap

7: Connecting rod bearing

8: Connecting rod

9: Connecting rod cap bolt

FUNCTION OF VGT SYSTEM

VGT Control System

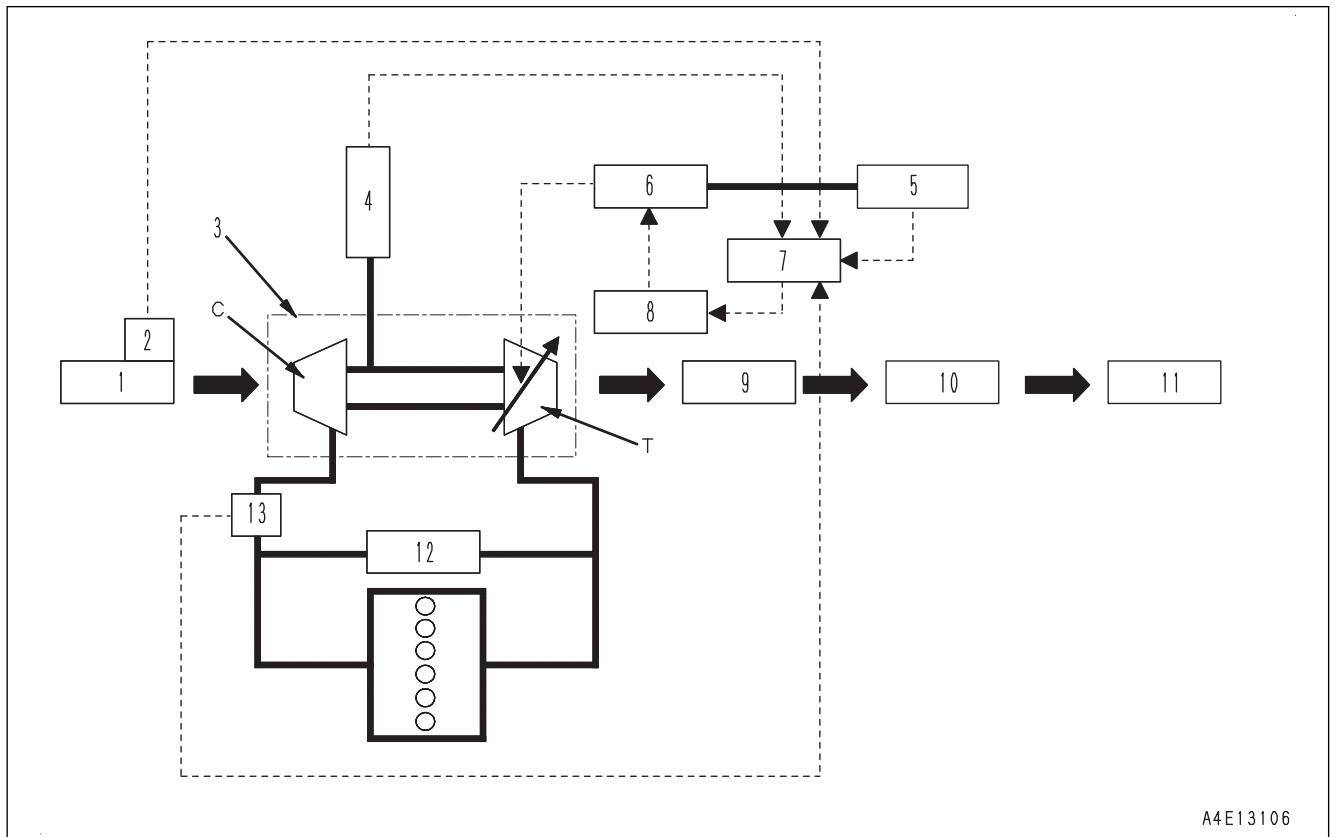

A4E13106

C: Blower impeller

1: Air cleaner

2: Mass air flow and temperature sensor

3: VGT

4: VGT speed sensor

5: VGT position sensor

6: Hydraulic actuator

7: Engine controller

*1: This may not be installed on some machine models and specifications.

- Engine controller (7) processes the data of VGT position sensor (5), intake air flow and temperature sensor (2), VGT speed sensor, etc. and sends the result to hydraulic actuator (6) via oil pressure controlled by EPC valve to move the piston.
- High altitude is recognized by the ambient pressure sensor, and the fuel injection and VGT are controlled automatically to secure better response at high altitude.
- The rotation of VGT is controlled to protect VGT from overspeed.

T: Turbine impeller

8: EPC valve (for VGT)

9: KDPF

10: AdBlue/DEF mixing tube(*1)

11: SCR assembly(*1)

12: EGR system (EGR cooler, EGR valve)

13: EGR valve lift sensor

Lubrication

- The lubricating oil cooled by the engine oil cooler is supplied through the feed pipe to VGT.
- The oil is sent to the bearing housing to lubricate the shaft bearing and thrust bearing.
- The return oil flows through the return pipe connected to under the bearing housing and falls into the engine oil pan.

Cooling

- The coolant from the cylinder block flows into the center housing to cool VGT.

EGR COOLER

EGR

Abbreviation for Exhaust Gas Recirculation

STRUCTURE OF EGR COOLER

REMARK

The shape is subject to machine models.

General view, sectional view

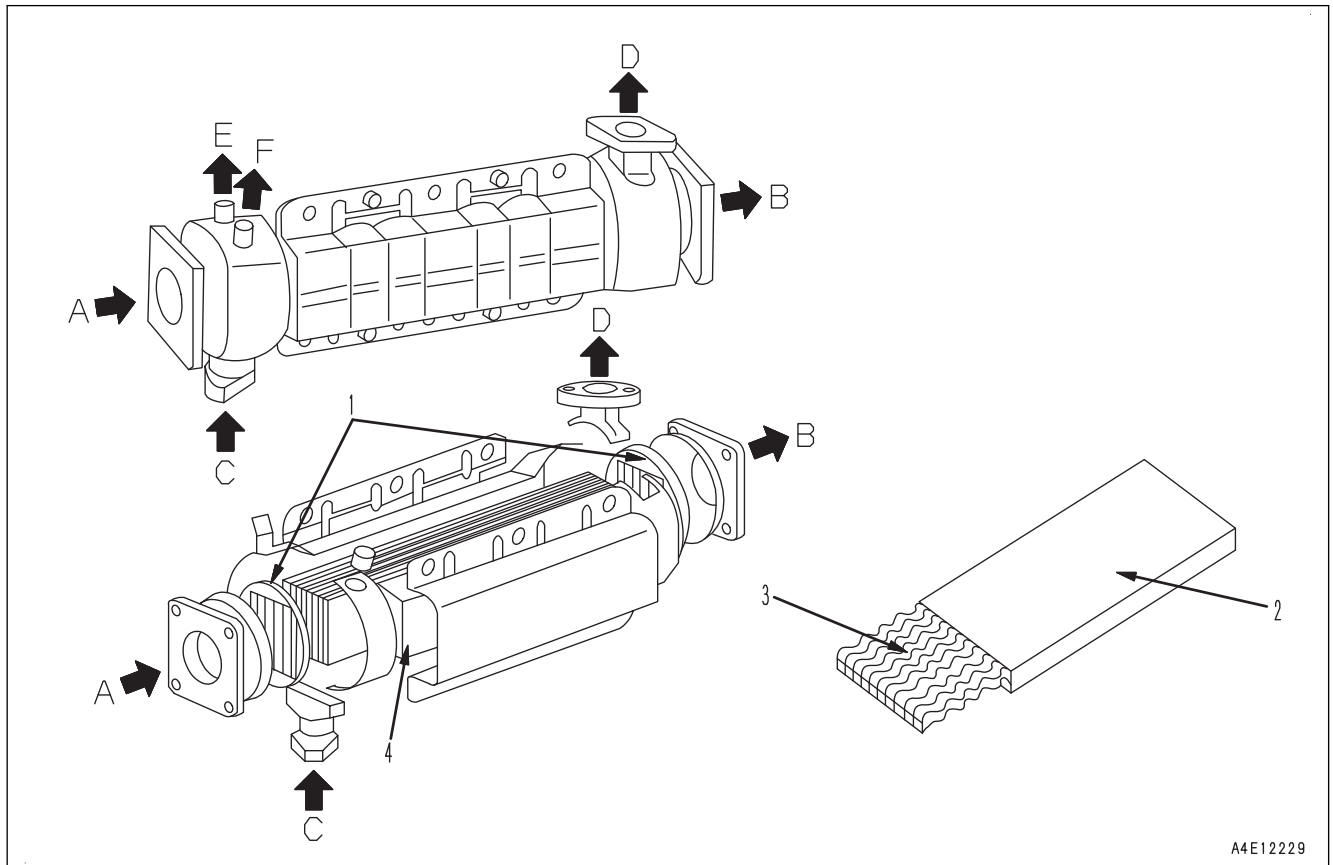

A4E12229

A: EGR gas inlet

B: EGR gas outlet (to EGR valve)

C: Coolant inlet

1: Header plate

2: Flat tube

D: Coolant outlet

E: Air vent

F: Air vent

3: Inner fin

4: Case

OPERATION OF EGR COOLER

- EGR gas enters through (A) and flows through flat tubes (2) (9 pieces).
- Coolant enters through (C), flows outside of flat tubes (2) in case (4), and goes out through (D).
- Flat tube (2) has inner fins (3), thus EGR gas is cooled efficiently and discharged through EGR gas outlet (B).

REMARK

When regeneration function on the machine monitor is disabled, or outside air temperature is extremely low, or continuous light load operation is carried out, relatively low exhaust temperature continues. In such case, "automatic regeneration" is not performed and the amount of soot accumulation is increased.

- If "automatic regeneration" is not performed due to the excess amount of accumulated soot in KCSF (2), perform "manual stationary regeneration" to burn (oxydize) the soot and reduce the amount of soot inside KCSF (2).

REMARK

Excessive amount of the soot interferes the flow of exhaust gas to worsen fuel consumption and engine combustion state. It may lead to other failures.

If the amount of soot increases further, "manual stationary regeneration" cannot be performed safely. This will result in a KDPF failure and replacement is unavoidable. Make sure to follow the procedures in the Operation and Maintenance Manual when performing "manual stationary regeneration"

*1: Soot purification (oxidation) treatment

TYPES OF REGENERATION FUNCTIONS

Regeneration means to purify (oxidize) the soot accumulated on the soot collecting filter (KCSF) in KDPF or maintain the urea SCR system normal.

Passive regeneration

When the exhaust temperature of the engine is relatively high, the oxidation power of soot in the exhaust gas components is increased by the catalysis of KDOC to oxidize (burn) the soot accumulated in KCSF naturally.

Active regeneration (engine exhaust temperature rise control + fuel dosing)

- Automatic regeneration
 - When soot is accumulated more than a certain level or the urea SCR system makes a request to maintain itself normal, the engine enters the exhaust temperature rise control mode (*1) and performs fuel dosing (*2) and starts regeneration automatically.
The automatic regeneration is also performed by the direction from the engine controller at a set time after the previous regeneration, regardless of soot accumulation in KCSF.
*1: Control to increase the engine exhaust temperature by controlling the fuel injection timing or VGT.
*2: Fuel injection performed to accelerate regeneration by increasing the exhaust temperature.
- Manual stationary regeneration
 - When the exhaust temperature does not reach a certain level, depending on the operating condition of the machine, or when the operator disables regeneration, the automatic regeneration is not performed and accumulated soot in KCSF increases. Also, when the automatic regeneration is performed upon receiving a request from the urea SCR system, the exhaust temperature may not reach a certain level, depending on the operating condition of the machine. In these cases, a request for the manual stationary regeneration request is displayed on the machine monitor, and the operator must perform regeneration by the operation on the machine monitor screen.
In addition, when the engine controller is replaced or ash in KCSF is washed, a serviceman performs regeneration by the operation on the machine monitor screen ("active regeneration for service").

3: Thermo valve

5: Thermo valve cover

4: Thermo valve spring

SPECIFICATIONS OF ENGINE OIL COOLER

Heat dissipation area: 1.23 m²

Quantity of heat exchange : Min. 39800kcal/h

OIL COOLER THERMO VALVE

STRUCTURE OF OIL COOLER THERMO VALVE

General view and sectional view

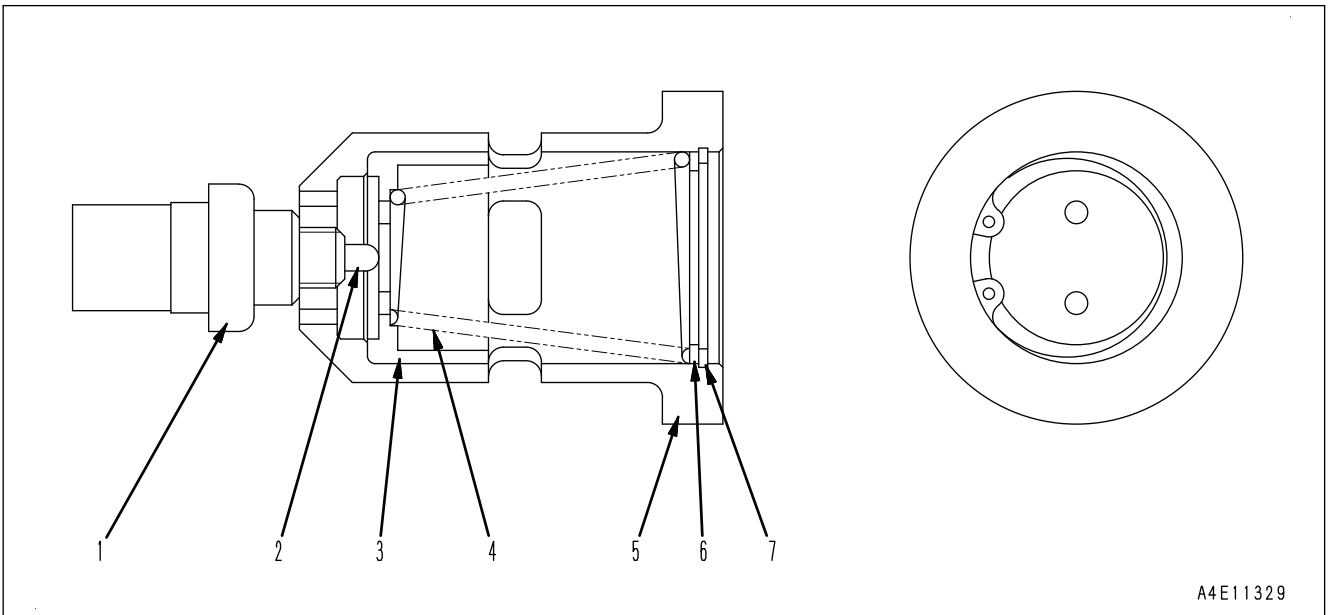

1: Pellet

5: Case

2: Piston

6: Washer

3: Valve

7: Ring

4: Spring

SPECIFICATIONS OF OIL COOLER THERMO VALVE

Cracking temperature: 85±2 °C

Full open temperature: 91±2 °C

Full open lift: Min. 7 mm

FUNCTION OF OIL COOLER THERMO VALVE

This valve is installed in the engine oil cooler, and prevents the engine oil from flowing into the cooler element until the engine oil reaches a certain temperature.

CLICK HERE TO **DOWNLOAD** THE COMPLETE MANUAL

- Thank you very much for reading the preview of the manual.
- You can download the complete manual from: www.heydownloads.com by clicking the link below



- Please note: If there is no response to CLICKING the link, please download this PDF first and then click on it.

CLICK HERE TO **DOWNLOAD** THE COMPLETE MANUAL

SUPPLY PUMP

STRUCTURE OF SUPPLY PUMP

Sectional view

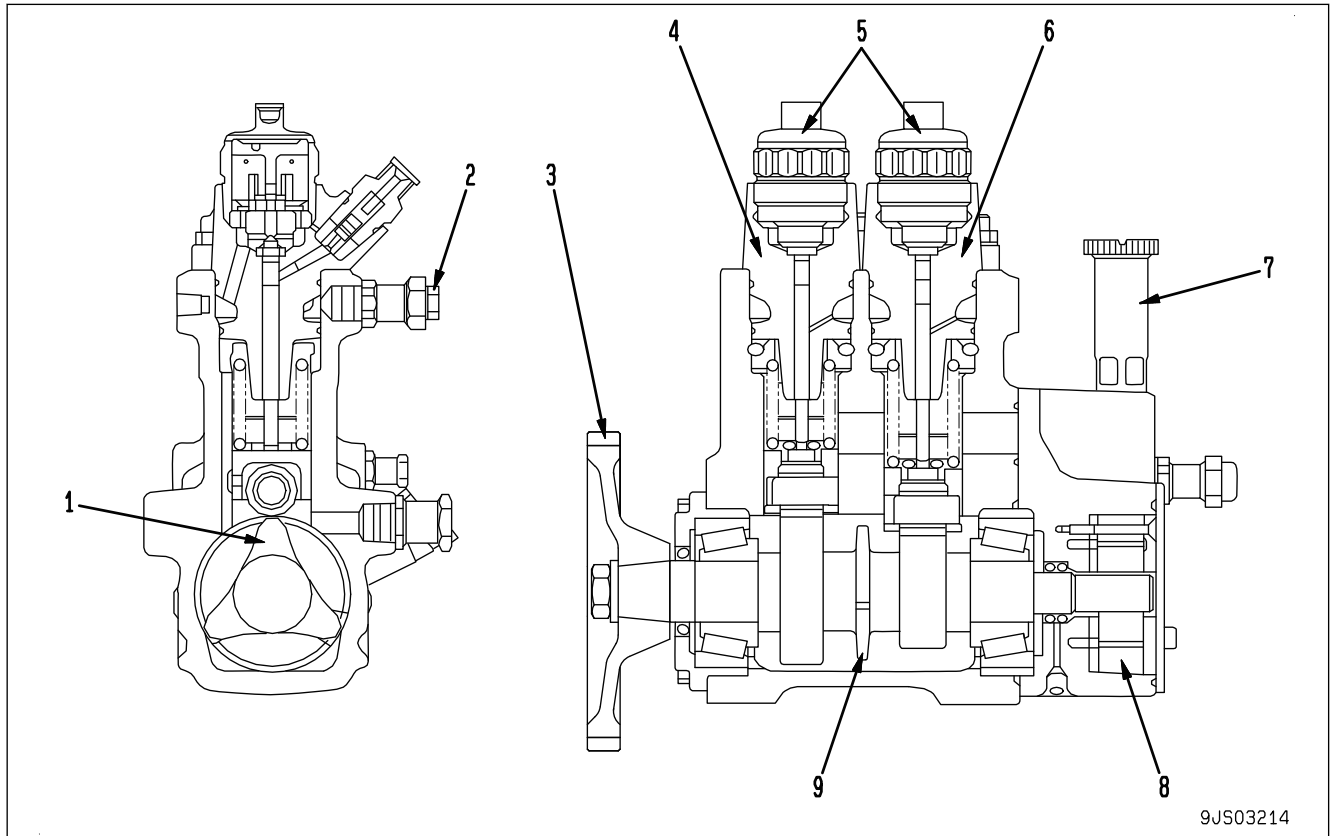

- | | |
|---|--|
| 1: 3-lobe cam | 6: No. 2 high-pressure pump (feed pump side) |
| 2: Overflow valve | 7: Priming pump |
| 3: Drive gear | 8: Feed pump |
| 4: No. 1 high-pressure pump (drive gear side) | 9: Gear for Bkup speed sensor (G sensor) |
| 5: PCV (pomp control valve) | |

Structure

- The supply pump consists of priming pump (7), feed pump (8), and high-pressure pumps (4) and (6).
- In each cylinder of high-pressure pumps (4) and (6), the pressure-feed system similar to the conventional in-line fuel injection pump and the PCV (pump control valve) (5) are arranged.
- By employing 3-lobe cam (1), the necessary number of cylinders in high-pressure pumps (4) and (6) is reduced to 1/3 of the number of the engine cylinders.
Also, since the pressure feed rate to the common rail is the same as the number of fuel injection, the fuel pressure in the common rail is stabilized.
- The fuel pressure-fed from high-pressure pumps (4) and (6) is divided as follows;
 - No. 1 high-pressure pump (drive gear side) compensates for reduction of common rail fuel pressure caused by fuel injection into No. 1, 3, and 5 cylinders.
 - No. 2 high-pressure pump (feed pump side) compensates for reduction of common rail fuel pressure in No. 2, 4, and 6 cylinders.

FUNCTION OF SUPPLY PUMP

- The supply pump controls the fuel discharged volume to generate the common rail fuel pressure.

- After active regeneration is finished, fuel doser solenoid valve (2) closes and stops supplying fuel. At the same time, the remaining pressure opens fuel doser solenoid valve 2 (3), and the fuel is drained.

FUEL DOSER

STRUCTURE OF FUEL DOSER

General view

- A: Fuel inlet
- B: Coolant inlet
- C: Coolant outlet
- 1: Fuel doser

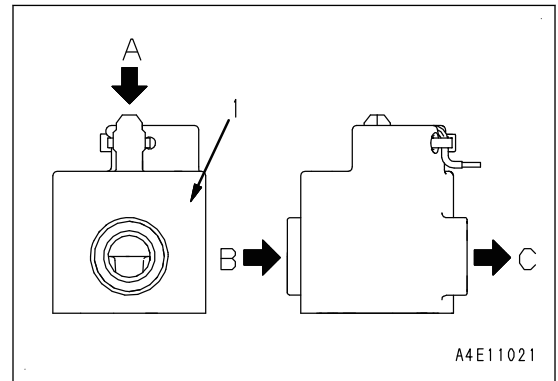

FUNCTION OF FUEL DOSER

- The fuel injection rate of fuel doser (1) is calculated by the engine controller to obtain proper KDOC outlet temperature.
- Fuel doser (1) is driven by PWM control to inject the calculated amount of fuel, according to the pressure sensed by the dosing fuel pressure sensor.

FUEL DOSER SOLENOID VALVE AND DOSER FUEL PRESSURE SENSOR

STRUCTURE OF FUEL DOSER SOLENOID VALVE AND DOSER FUEL PRESSURE SENSOR

General view

- A: Fuel inlet
- B: Fuel outlet (to fuel doser)
- C: Fuel outlet (drain)
- 1: Fuel doser solenoid valve 1
- 2: Fuel doser solenoid valve 2
- 3: Fuel dosing pressure sensor

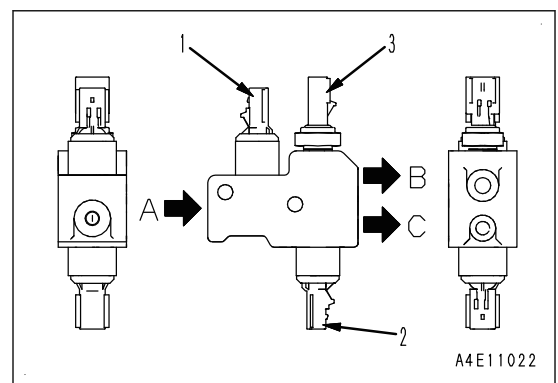

FUNCTION OF FUEL DOSER SOLENOID VALVE AND DOSER FUEL PRESSURE SENSOR

- Fuel doser solenoid valves (1) and (2) and doser fuel pressure sensor (3) are assembled as a fuel doser solenoid valve assembly.
- A mesh filter is installed to fuel inlet (A) of the fuel doser solenoid valve assembly.
- The fuel pressure supplied to the fuel doser is measured by doser fuel pressure sensor (3).
- After active regeneration is finished, fuel doser solenoid valve (1) closes and stops supplying fuel. At the same time, the remaining pressure opens fuel doser solenoid valve (2) and the fuel is drained.

SPECIFICATIONS OF ALTERNATOR WITH BUILT-IN REGULATOR (OPEN TYPE, 90A)

Type: Open type manufactured by NIKKO DENKI (brushless)

Specifications: 24 V, 90 A

Number of pulley grooves: 8

Pulley outside diameter: 85 mm

Weight: 19 kg

STRUCTURE OF ALTERNATOR WITH BUILT-IN REGULATOR (OPEN TYPE, 140A)

REMARK

The shape is subject to machine models.

General view and circuit diagram

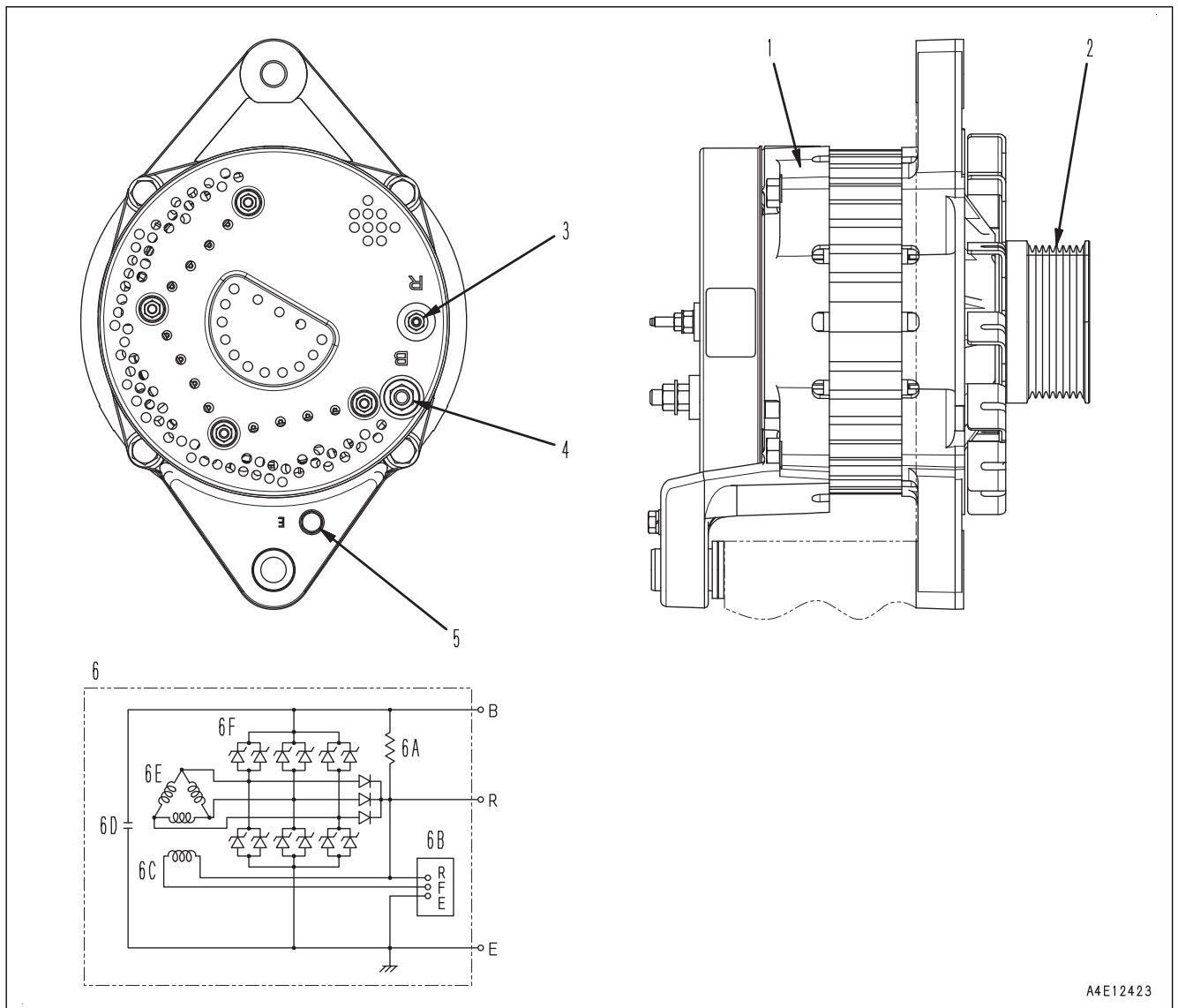

A4E12423

1: Alternator (body)

2: Alternator pulley

3: Terminal R

4: Terminal B

5: Terminal E

6: Internal wiring diagram

6A: Initial excitation resistance

6B: Regulator

Pin No.	Signal name	Input/Output
37	Dosing fuel pressure sensor	Input
38	(*1)	-
39	(*1)	-
40	(*1)	-
41	(*1)	-
42	(*1)	-
43	(*1)	-
44	Ambient pressure sensor	Input
45	Charge pressure sensor	Input
46	(*1)	-
47	(*1)	-
48	PCV2 (-)	Ground/Shield/ Return
49	Injector #4 (+)	Output
50	Injector #5 (+)	Output
51	Injector #6 (+)	Output
52	(*1)	-
53	(*1)	-
54	GND	Ground/Shield/ Return
55	GND	Ground/Shield/ Return
56	GND	Ground/Shield/ Return
57	GND	Ground/Shield/ Return
58	GND	Ground/Shield/ Return
59	(*1)	-
60	(*1)	-
61	Intake air temperature sensor	Input
62	Charge temperature sensor	Input
63	Crankcase pressure sensor	Input
64	(*1)	-
65	(*1)	-
66	(*1)	-
67	VGT position sensor	Input
68	(*1)	-
69	(*1)	-
70	Datalink3 (+) (KOMNET/r)	Communication
71	(*1)	-

STRUCTURE OF AMBIENT PRESSURE SENSOR

Ambient pressure sensor is attached to the air intake cover part on the top of engine.

General view

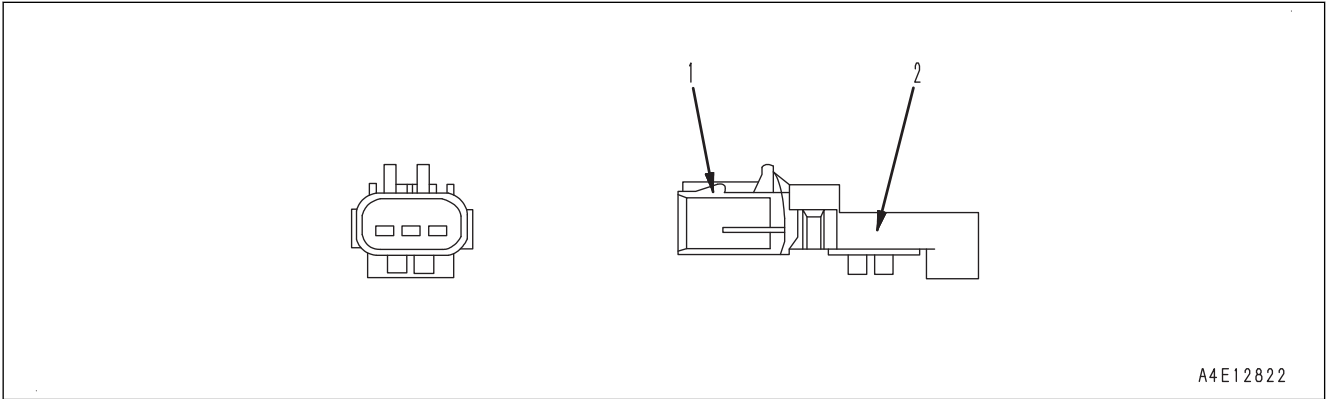

1: Connector (FRAMATOME-3P)

2: Sensor

FUNCTION OF AMBIENT PRESSURE SENSOR

It detects ambient pressure and outputs a variable voltage.

Output characteristics

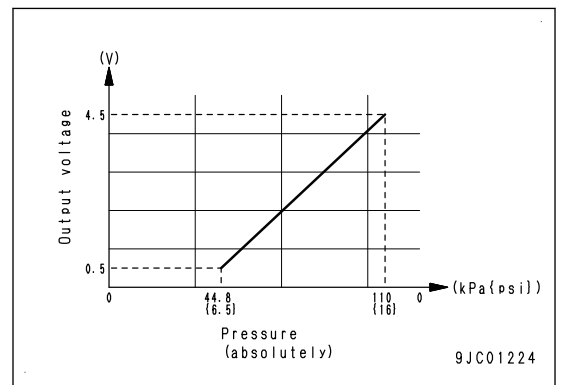

STRUCTURE OF VGT POSITION SENSOR

VGT position sensor is attached to VGT of engine.

General view

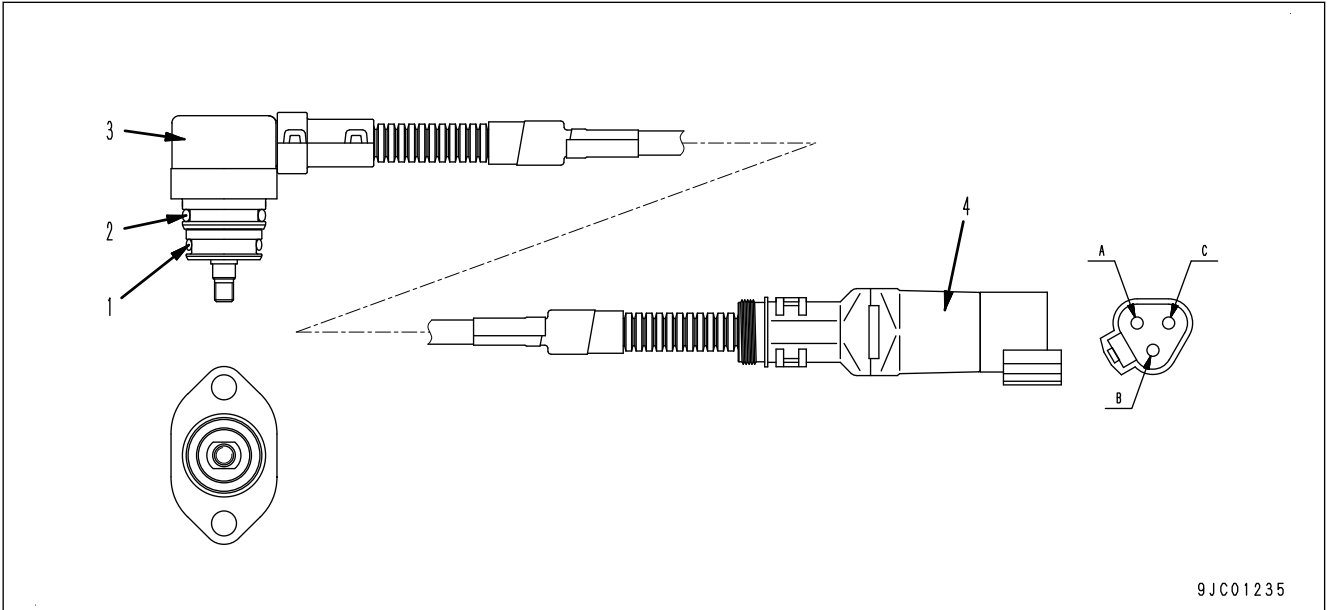

1: O-ring (small)

3: Sensor

2: O-ring (big)

4: Connector

FUNCTION OF VGT POSITION SENSOR

It detects the position of nozzle ring which is built in VGT and outputs a corresponding variable voltage.

Output characteristics

The relation between stroke and output voltage is shown in following graph.

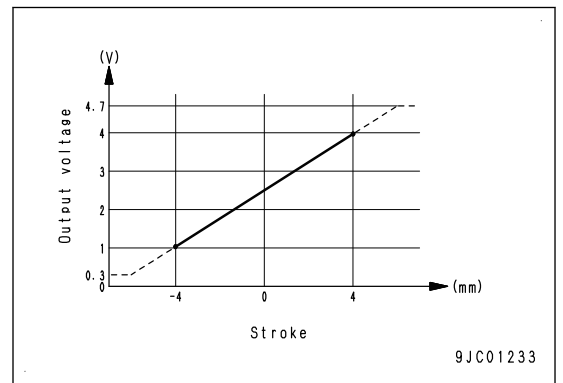

ABBREVIATION LIST

- This list of abbreviations includes the abbreviations used in the text of the shop manual for parts, components, and functions whose meaning is not immediately clear. The spelling is given in full with an outline of the meaning.
- Abbreviations that are used in general society may not be included.
- Special abbreviations which appear infrequently are noted in the text.
- This list of abbreviations consists of two parts. The first part is a list of the abbreviations used in the text of the manual, and the second part is a list of the abbreviations used in the circuit diagrams.

List of abbreviations used in the text

Abbreviation	Actual word spelled out	Purpose of use (major applicable machine (*1), or component/system)	Explanation
ABS	Antilock Brake System	Travel and brake (HD, HM)	This is a function that releases the brake when the tires skid (tires are not rotated). This function applies the brake again when the tires rotate.
AISS	Automatic Idling Setting System	Engine	This is a function that automatically sets the idle speed.
AJSS	Advanced Joystick Steering System	Steering (WA)	This is a function that performs the steering operations with a lever instead of using a steering wheel. This function performs gear shifting and changing forward and reverse direction.
ARAC	Automatic Retarder Accelerator Control	Travel and brake (HD, HM)	This is a function that automatically operates the retarder with a constant braking force when letting go of the accelerator pedal on the downhill.
ARSC	Automatic Retarder Speed Control	Travel and brake (HD, HM)	This is a function that automatically operates the retarder to ensure that the machine speed does not accelerate above the speed set by the operator when letting go of the accelerator pedal on the downhill.
ASR	Automatic Spin Regulator	Travel and brake (HD, HM)	This is a function that drives both wheels automatically using the optimum braking force when the tire on one side spins on the soft ground surfaces.
ATT	Attachment	Work equipment	A function or component that can be added to the standard specification.
BCV	Brake cooling oil control valve	BRAKE (HD)	This is a valve that bypasses a part of the brake cooling oil to reduce the load applied to the hydraulic pump when the retarder is not being used.
CAN	Controller Area Network	Communication and electronic control	This is one of communication standards that are used in the network on the machine.
CDR	Crankcase Depression Regulator	Engine	This is a regulator valve that is installed to KCCV ventilator. It is written as CDR valve and is not used independently.
CLSS	Closed-center Load Sensing System	Hydraulic system	This is a system that can actuate multiple actuators simultaneously regardless of the load (provides better combined operation than OLSS).

STANDARD VALUE TABLE FOR ENGINE: SAA6D140E-7 (HM400-5, HM400-5E0)

Performance

Engine			SAA6D140E-7		
Item	Measurement condition		Unit	Standard value for new machine	Repair limit
Engine speed	Engine coolant temperature: 60 to 102 °C	Max. speed with no load (high idle)	rpm	2200 (+50 / +0)	2200 (+50 / 0)
		Min. speed with no load (low idle)		725±25	725±25

Air intake and exhaust system

Engine			SAA6D140E-7		
Item	Measurement condition		Unit	Standard value for new machine	Repair limit
Air intake resistance	Whole speed range		kPa { mmH ₂ O}	Max. 3.73 {Max. 380}	Max. 7.47 {Max.762}
Boost pressure	At rated horsepower (gauge pressure)		kPa { mmHg}	Min. 163 {Min. 1220}	Min. 145 {Min.1090}
Exhaust temperature	Whole speed range (ambient temperature 20 °C)		°C	Max. 670	700
Exhaust gas color	<ul style="list-style-type: none"> Engine coolant temperature: 60 to 102 °C At rated horsepower After keeping for 5 seconds at normal condition 	Engine outlet (between VGT and KDPF inlet)	Bosch index	-	Max. 3.0
		SCP outlet (exhaust pipe outlet)		-	Max. 0.5
Valve clearance	Intake valve		mm	0.35	-
	Exhaust valve			0.57	-
EGR valve oil pressure and VGT oil pressure	At Max. speed with no load (High idle)		MPa { kg/cm ² }	Min. 1.43 {Min. 14.6}	Min. 1.43 {Min. 14.6}
	At Min. speed with no load (Low idle)			Min. 1.18 {Min. 12.0}	Min. 1.18 {Min. 12.0}

Main body

Engine			SAA6D140E-7		
Item	Measurement condition		Unit	Standard value for new machine	Repair limit
Compression pressure	<ul style="list-style-type: none"> Engine oil temperature: 40 to 60 °C Engine speed: 200 to 280 rpm 		MPa { kg/cm ² }	Min. 4.1 {Min. 42}	Min. 2.8 {Min. 29}
Blowby pressure	At rated horsepower (when KCCV is disconnected)		kPa { mmH ₂ O}	Max. 3.92 {Max. 400}	Max. 4.90 {Max. 500}

**RUNNING-IN STANDARD AND PERFORMANCE TEST STANDARD:
SAA6D140E-7 (HM400-5, HM400-5E0)****Running-in standard**

Engine		SAA6D140E-7				
Item		Procedure				
		1	2	3	4	5
Running time	min	1	3	6	8	2
Engine speed	rpm	725	1260	1580	1820	2000
Dynamometer load	N { kg}	0 {0}	934 {95}	1490 {152}	1940 {198}	2354 {240}
Output	kW{HP}	0 {0}	88 {118}	177 {237}	265 {355}	353 {473}

REMARK

- This table shows the values when the fan is not installed.
- The loads for the dynamometer in this table shows the value when the dynamometer arm is 716 mm long.

Performance test standard

Engine		SAA6D140E-7			
Test item		Rated horsepower	Max. torque	Max. speed with no load	Min. speed with no load
Specification value (Gross value)	-	353 kW/2000 rpm {473 HP/2000 rpm}	2275 Nm/ 1400 rpm {232 kgm/ 1400 rpm}	2200 (+50 / 0)	725±25
Engine speed	rpm	2000	1400	2200 (+50 / 0)	725±25
Dynamometer load	N { kg}	2283 to 2424 {233 to 247}	3082 to 3273 {314 to 334}	-	-
Output (Gross value)	kW{HP}	343 to 363 {460 to 487}	-	-	-
Torque (Gross value)	Nm { kgm}	-	2206 to 2243 {225 to 239}	-	-
Fuel consumption	cc/sec	27.0	-	-	-
Coolant temperature	°C	70 to 90	70 to 90	70 to 90	70 to 90
Lubricating oil temperature	°C	90 to 110	90 to 110	90 to 110	80 to 110
Lubricating oil pressure	kPa { kg/cm ² }	340 to 490 {3.5 to 5.0}	340 to 490 {3.5 to 5.0}	340 to 490 {3.5 to 5.0}	Min. 120 {Min. 1.2}
Exhaust temperature	°C	Max. 620	Max. 670	-	-

Abbreviation	Actual word spelled out	Purpose of use (major applicable machine (*1), or component/system)	Explanation
ICT	Information and Communication Technology	Communication and electronic control	A general term for the engineering and its socially applied technology of information processing and communication.
IMA	Inlet Metering Actuator	Engine	This is a valve that adjusts the fuel intake amount at the pump inlet in order to control the supply pump fuel discharged volume. (Same as IMV)
IMU	Inertial Measurement Unit	Engine	This is a device to detect the angle (or angular velocity) and acceleration of the 3 axes that control motions.
IMV	Inlet Metering Valve	Engine	This is a valve that adjusts the fuel intake amount at the pump inlet in order to control the supply pump combustion discharged volume. (Same as IMA)
KCCV	Komatsu Closed Crankcase Ventilation	Engine	This is a mechanism that burns the blowby gas again by separating oil from blowby gas and returning it to the intake side. It primarily consists of filters.
KCSF	Komatsu Catalyzed Soot Filter	Engine	This is a filter that captures soot in exhaust gas. It is built in to KDPF.
KDOC	Komatsu Diesel Oxidation Catalyst	Engine	This is a catalyst that is used for purifying exhaust gas. It is built in to KDPF or assembled with the muffler.
KDPF	Komatsu Diesel Particulate Filter	Engine	This is a component that is used to purify the exhaust gas. KDOC (catalyst) and KCSF (filter to capture soot) are built-in it. It is installed instead of the conventional muffler.
KTCS	Komatsu Traction Control System	Travel and brake (HM)	This is a function that performs braking with the optimum force and recovers the driving force of the wheels by actuating the inter-axle differential lock when the wheels runs idle while the machine travels on the soft ground.
LCD	Liquid Crystal Display	Machine monitor	This is an image display equipment such as a monitor in which the liquid crystal elements are assembled.
LED	Light Emitting Diode	Electronic parts	This is a semiconductor element that emits light when the voltage is applied in forward direction.
LIN	Local Interconnect Network	Communication and electronic control	This is one of communication standards that are used in the network on the machine.
LS	Load Sensing	Hydraulic system	This is a function that detects differential pressure of pump, and controls discharged volume corresponding to load.
LVDS	Low Voltage Differential Signaling	Communication and electronic control	This is one of communication standards that are used in the network on the machine.
MAF	Mass Air Flow	Engine	This indicates engine intake air flow. This is not used independently but is used as combined with sensor. Mass air flow sensor can be called as MAF sensor.

SPECIAL TOOLS LIST

How to read the tool list

- Part Number:
Tools with part number 79*T-***-**** are not supplied (to be locally manufactured).
- Necessity
 - : Not substitutable, and work cannot be performed without the tool.
 - : Tools extremely useful if available or tools that can be substituted with commercially available tool.
- New/Redesign
 - N: Tools with new part numbers, newly developed for this model.
 - R: Tools, with advanced part numbers, developed by improving existing tools for other models.
 - Blank: Tools already available for other models that can be used without any modification.
- Sketch
 - : Tools marked with ○ in the sketch column have the sketches.
 Sketches are introduced in "Sketches of special tools", and all sketches of "79*T-***-****" are described.

Tools for removal and installation of supply pump assembly

Symbol	Part No.	Part name	Necessity	Qty	New/Redesign	Sketch	Remarks
A	1	790-501-2001	Engine repair stand	■	1		Disassembly and assembly of engine assembly
	2	790-901-1261	Bracket	■	1		
C	795-102-2103	Spring pusher	■	1			Removal and installation of cylinder head valve spring
D	795-100-1191	Piston ring tool	■	1			Removal and installation of piston ring
E	795-236-1000	Liner puller	■	1			Removal of cylinder liner
F	795-230-5472	Liner screwdriver	■	1			Press fit of cylinder liner
G	795-921-1100	Piston holder	■	1			Insertion of piston assembly
H	795-502-1121	Gauge holder	■	1			Measure the protrusion of cylinder liner
I	795-125-1210	Feeler gauge	●	1			Valve clearance adjustment
J	790-331-1110	Wrench	●	1			Angle tightening of bolts
L	795-931-1100	Seal puller	■	1			Removal of oil seal
M	1	795T-521-1111	Push tool	■	1		Press-fit of engine front oil seal (standard type)
		01050-31655	Bolt	■	3		
		01050-31635	Bolt	■	3		
	2	795T-521-1150	Push tool	■	1		Press-fit of engine front oil seal (sleeve type)
		01050-31635	Bolt	■	3		

19. Remove heat insulation plates (9), (9a), (10), (11), (12), and bracket (13).

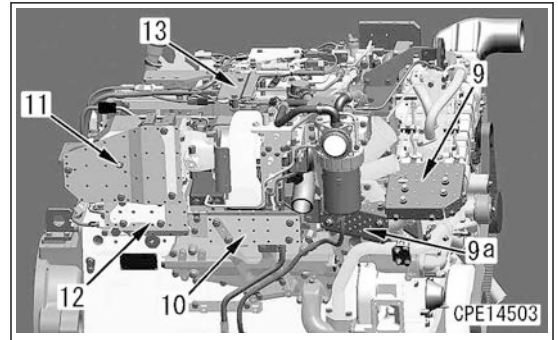

20. Remove cover (14).

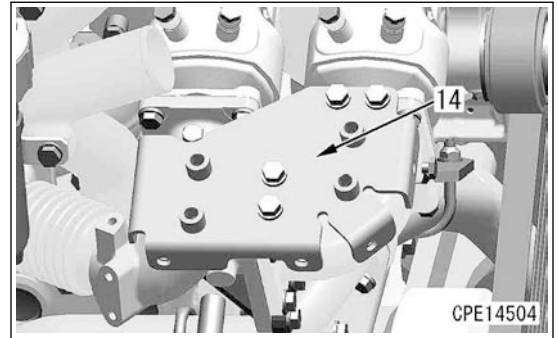

21. Remove doser connector (15a) together as a unit with exhaust elbow (15b).

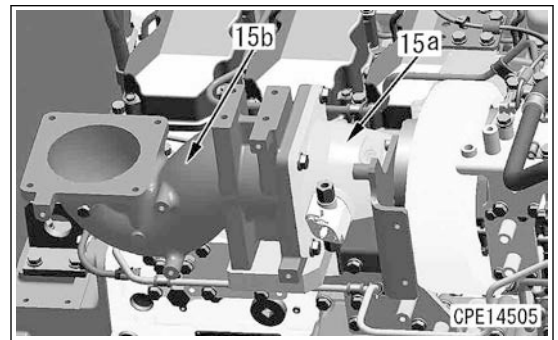

22. Remove VGT coolant tube (16) and oil drain tube (17).

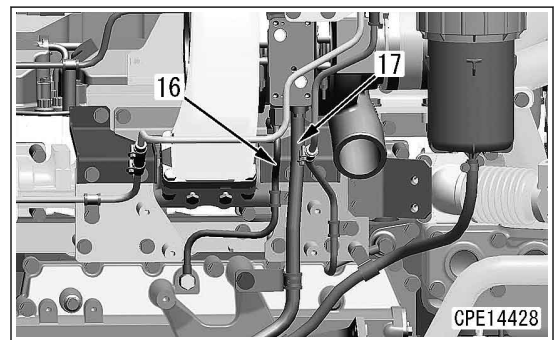

23. Disconnect the following connectors.

- (18): PIM
- (19): TIM
- (20): TWTR

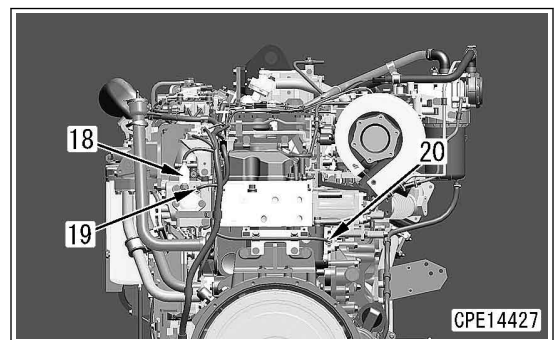

- 105. Remove the special bolt (15a), and remove common rail (15).
- 106. Remove the fuel feed pump (16).

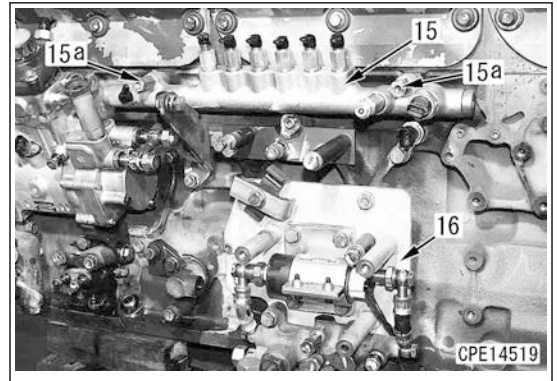

Supply pump, EGR oil pump

- 107. Remove the mounting bolts, and remove supply pump (1).

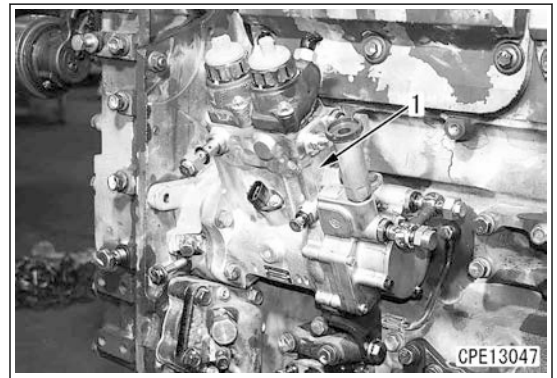

- 108. Remove the mounting bolts, and remove oil junction block (2) and EGR oil pump (3).

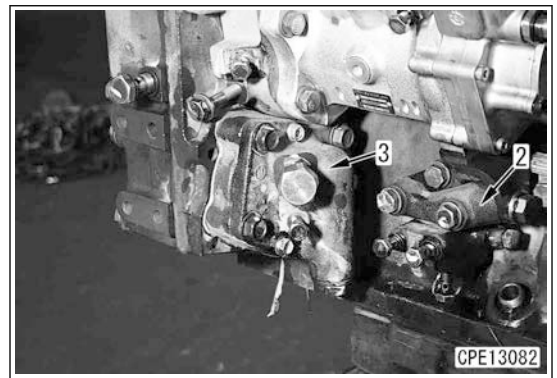

Rocker arm, Shaft assembly

- 109. Remove 3 mounting bolts (3), and remove rocker arm and shaft assembly (4).
- 110. Loosen locknut (2) and loosen adjustment screw (1) sufficiently so that an excessive force is not applied to the adjustment bolt when removing and installing.

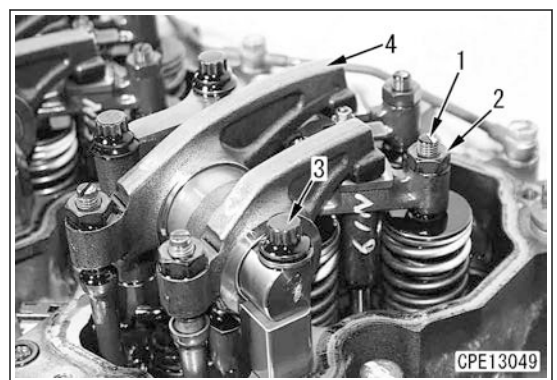

METHOD FOR ASSEMBLING ENGINE GENERALLY

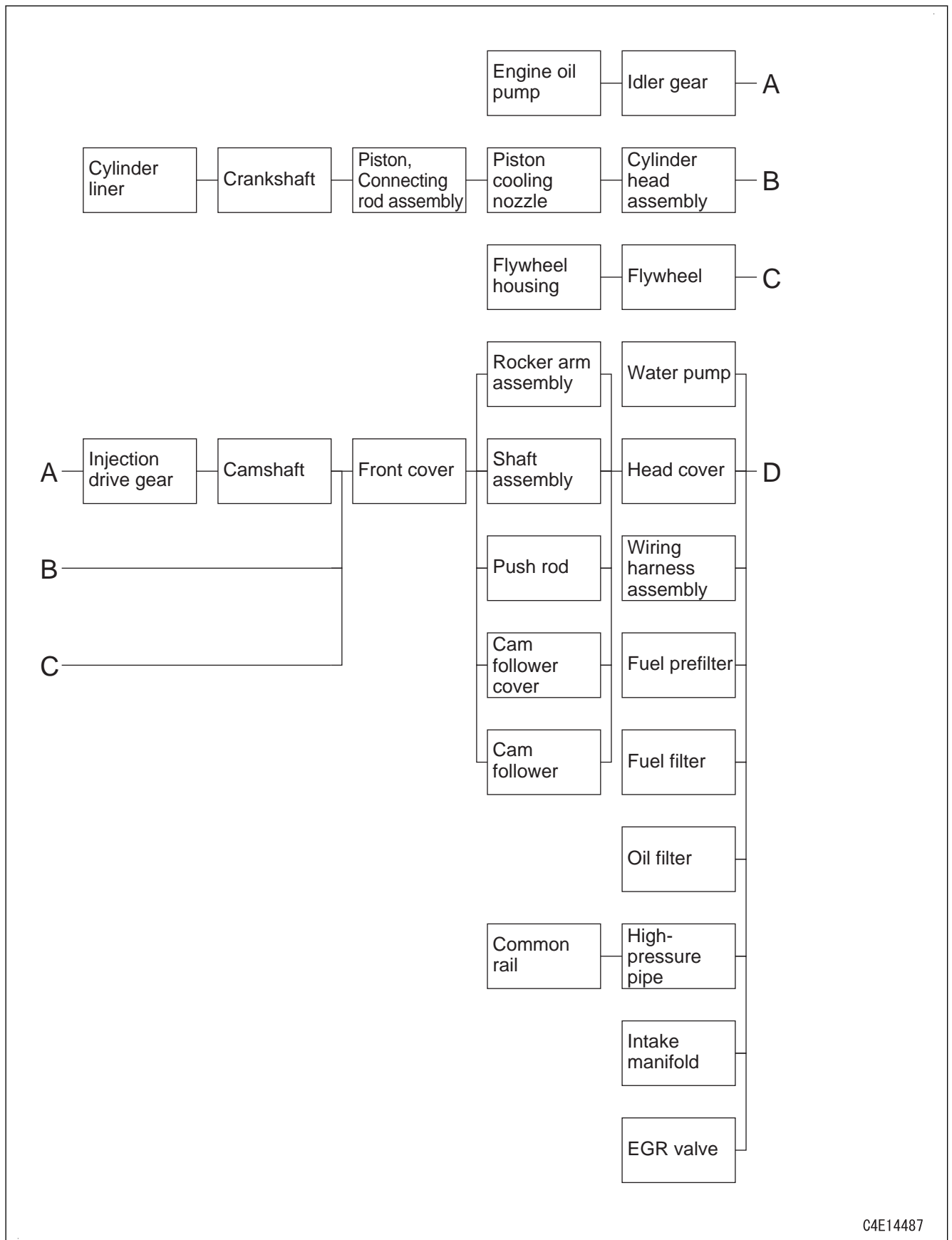

C4E14487

42. Put 1 punch mark (c) on the head of mounting bolt after tightening.

REMARK

When using a brand new bolt, do not put a punch mark.

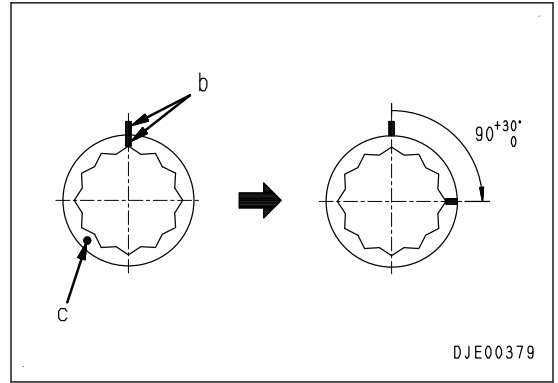

43. Rotate the crankshaft and check that it rotates smoothly.
 44. Measure the side clearance of the connecting rod with dial gauge [1].

REMARK

- Side clearance: 0.100 to 0.274 mm
- If it is out of standard value, take actions by referring to "Maintenance Standard".

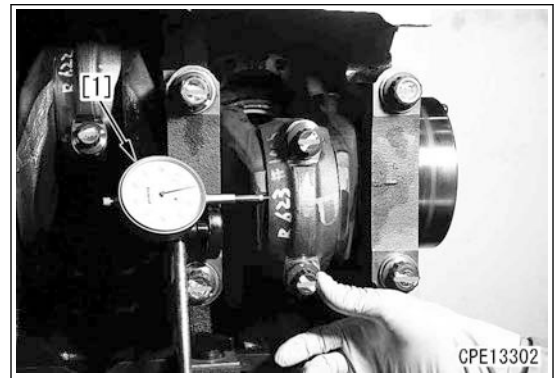

Piston cooling nozzle

45. Rotate the crankshaft to set pistons No. 1 to No. 3 corresponding to the mounting position.
 No.1 top: No.1 & No.6 installable
 No.2 top: No.2 & No.5 installable
 No.3 top: No.3 & No.4 installable
46. Install piston cooling nozzle (1) and plate (2) to each cylinders in a sequential order.

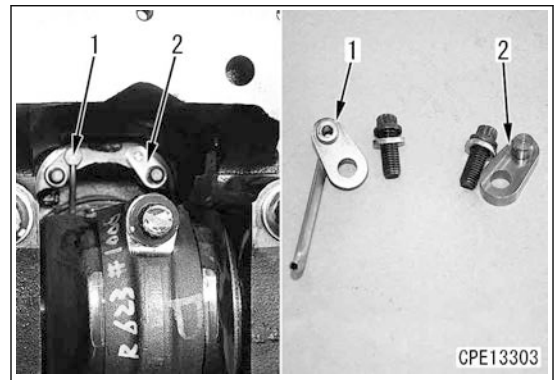

REMARK

- Install the piston ring cooling nozzle to the front of the engine and install the plate to the rear of the engine.
- After assembling the piston and connecting rod, check the position of the nozzle is at the center of oil gallery inlet. Check presence/absence of interference between piston and piston cooling nozzle.



Flywheel housing

47. Apply liquid gasket 1 mm in diameter to the position (a) in the figure.

-  Mating face:
Liquid gasket (LG-7)
-  Threaded portion of bolt, Seat surface:
Engine oil (EO30)

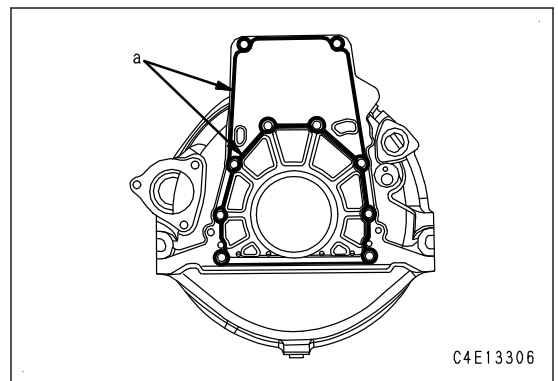

79. Apply force to the metal ring of seal (1) evenly by hands, and push in plastic inner tube like riding over the larger inside diameter side.

REMARK

Evenly tap by using a plastic hammer to push it in while preventing the metal ring from being deformed.

80. After pushing in seal, remove inner plastic tube (2).

REMARK

Be careful not to damage the seal lip while removing it.

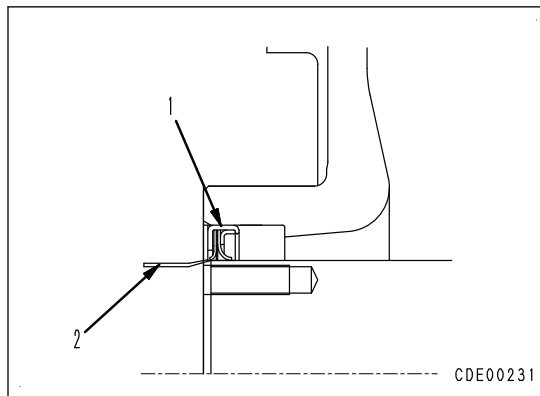

81. Use the tool M1 to tighten the bolts (3 pieces) evenly until the tip of tool M1 hits the sides of crankshaft (5)

REMARK

- Firstly, tighten 55 mm bolt until the very end. Secondly, replace the bolt with 35 mm bolt and tighten it.
- Installed dimension (a) of seal from crank shaft 9.1 to 10.1 mm
- Be careful not to damage the seal lip by the tool set when press-fitting the seal.
- After press-fitting seal, remove the red sealant layer from its outer periphery.

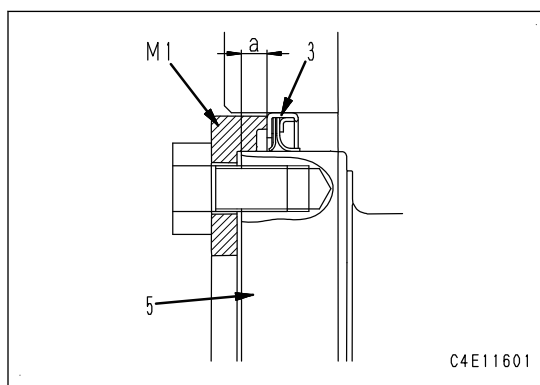

Damper assembly

82. Sling damper assembly (1), match it with the dowel pin, and tighten mounting bolts (2) (6 pieces).



Damper assembly (1):

45 kg



Mounting bolt (2):

245 to 309 Nm {25 to 31.5 kgm}

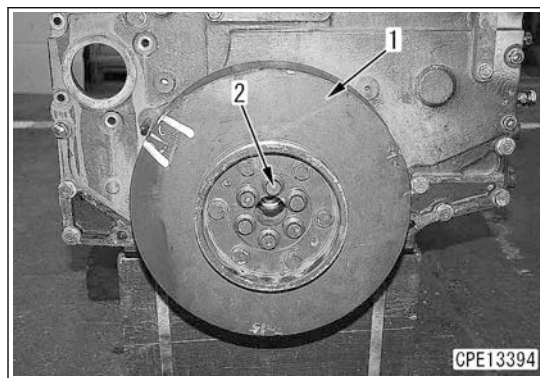

Cylinder head assembly

83. Use tool Q to press-fit valve system seal (5) until it hits the valve guide.

84. Install valve (7).



Valve stem:

Engine oil (EO30)

85. Install lower seal (6).

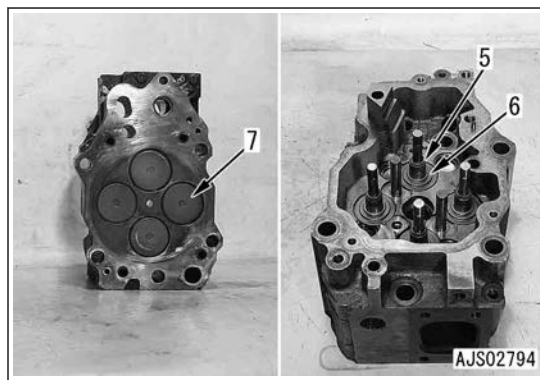

Fuel cooling plate

- 119. Install O-ring and then install lock plate (1).
- 120. Install bracket (2).
- 121. Install clamps (3) and (4).

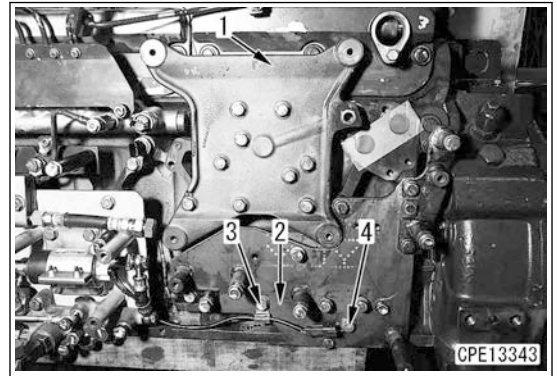

- 122. Install fuel cooling plate (5).
- 123. Install fuel tube (6).

 Fuel tube (6):
84 to 132 Nm {8.5 to 13.5 kgm}

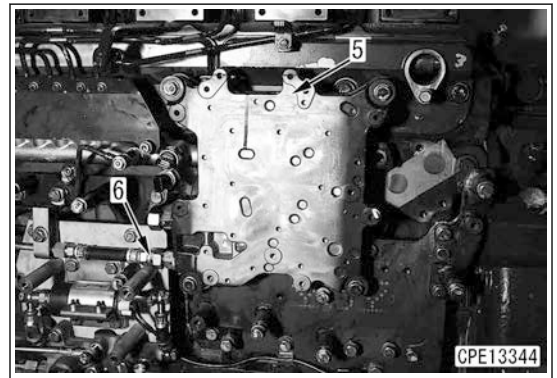

Wiring harness

- 124. Connect the connectors CN1 to CN6.
- 125. Tighten the temporarily tightened bolts of cylinder head cover and install harness (1) to clamp.



Fuel tube

- 126. Install fuel tube (1).

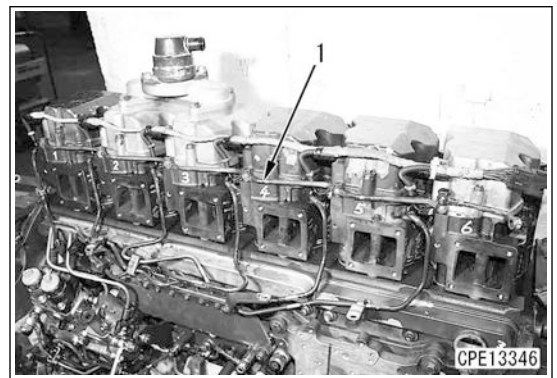

201. Install doser connector (24a) together as a unit with exhaust elbow (24b).

 Fuel doser (24c):
 $9.0 \pm 0.5 \text{ Nm}$ {0.09 to $\pm 0.05 \text{ kgm}$ }

REMARK

- After tightening it to the specified torque, tighten it again to the specified torque.
- Be careful not to drop heat insulator and gasket while installing them.

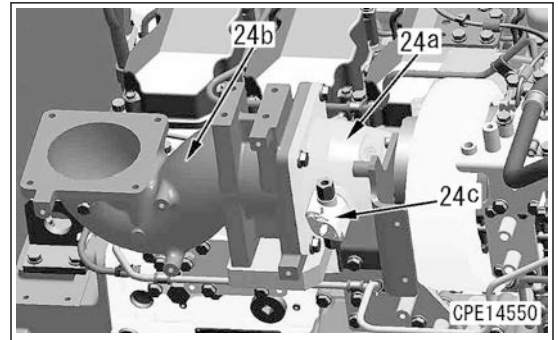

202. Install cover (25).

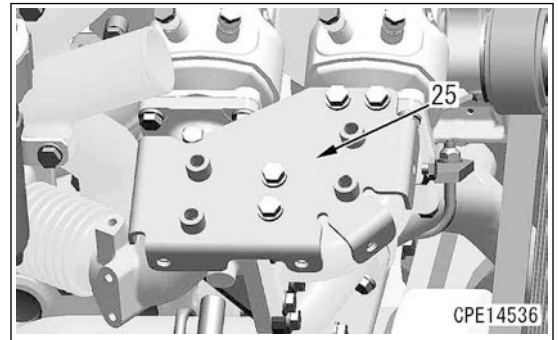

203. Install heat insulation plates (30), (30a), (29), (28), (27) and bracket (26).

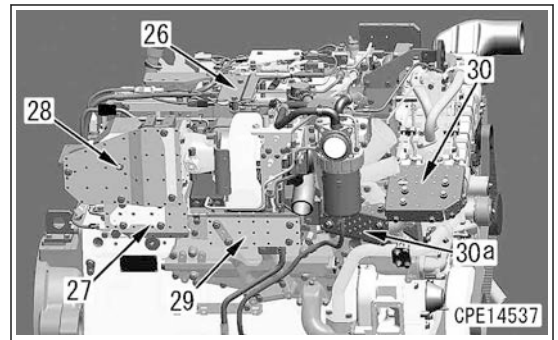



204. Install the mounting bolts, and remove bracket (31).

205. Install clips (32).

206. Connect coolant tubes (35) and (33), and also fuel doser hose (34).

 Joint bolts (35) and (33):
 $24.5 \text{ to } 34.3 \text{ Nm}$ {2.5 to 3.5 kgm}

 fuel doser hose (34) (fuel doser solenoid valve side):
 $1.96 \text{ to } 29.4 \text{ Nm}$ {2.0 to 3.0 kgm}

 fuel doser hose (34) (fuel doser side):
 $15.3 \pm 0.5 \text{ Nm}$ {1.56 to $\pm 0.05 \text{ kgm}$ }

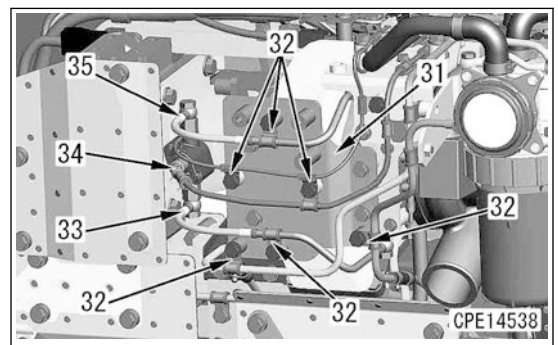

207. Remove the mounting bolts, and install bracket (36a).

208. Install Nox sensor (36).

209. Install clips (37).

210. Connect connector DOSER (38).

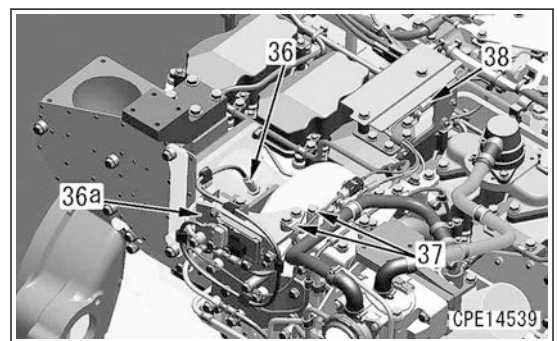

REMOVE AND INSTALL ENGINE REAR OIL SEAL

METHOD FOR REMOVING ENGINE REAR OIL SEAL

Flywheel

1. Install eyebolt [1].
2. Remove the mounting bolts and remove flywheel (1) by using the guide bolts.

 Flywheel (1):
60 kg

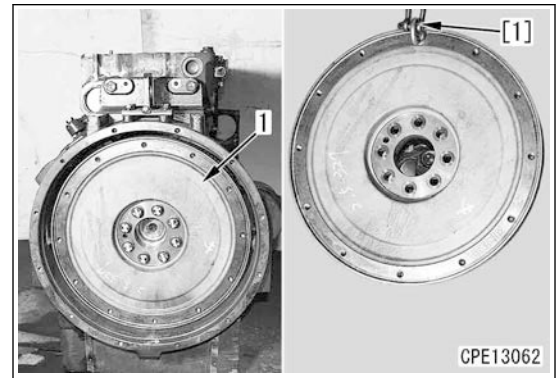

Rear oil seal

Left: Standard seal, Right: Sleeved seal

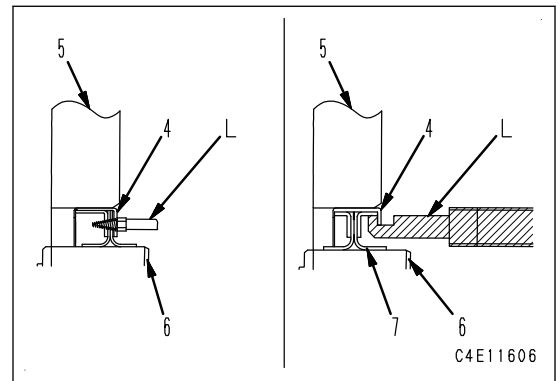

3. Standard seal

- 1) Drill the several holes of approximately 3 mm in diameter on rear seal (4).
- 2) Select the drill type (DT) for the tip of tool L.
- 3) Insert the tip of tool L into the drilled holes in step 1). Remove it by using the impact power of slide hammer (SH). (Perform this evenly to prevent the rear seal from inclining.)

4. Sleeved seal

- 1) Cut sleeve (7), and remove it by using a chisel and a hammer, or such.
- 2) Select the puller type (PT) for the tip of tool L.
- 3) Hook the tip of tool L on the metal ring of rear seal, and pull it out by using the impact power of slide hammer (SH).

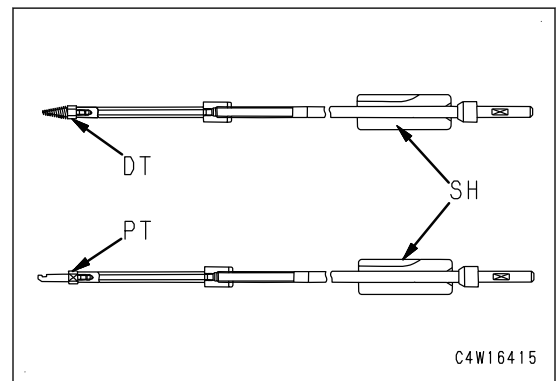

REMARK

- Remove chips securely.
- Be careful not to damage crankshaft (6).

Abbreviation	Actual word spelled out	Purpose of use (major applicable machine (*1), or component/system)	Explanation
ICT	Information and Communication Technology	Communication and electronic control	A general term for the engineering and its socially applied technology of information processing and communication.
IMA	Inlet Metering Actuator	Engine	This is a valve that adjusts the fuel intake amount at the pump inlet in order to control the supply pump fuel discharged volume. (Same as IMV)
IMU	Inertial Measurement Unit	Engine	This is a device to detect the angle (or angular velocity) and acceleration of the 3 axes that control motions.
IMV	Inlet Metering Valve	Engine	This is a valve that adjusts the fuel intake amount at the pump inlet in order to control the supply pump combustion discharged volume. (Same as IMA)
KCCV	Komatsu Closed Crankcase Ventilation	Engine	This is a mechanism that burns the blowby gas again by separating oil from blowby gas and returning it to the intake side. It primarily consists of filters.
KCSF	Komatsu Catalyzed Soot Filter	Engine	This is a filter that captures soot in exhaust gas. It is built in to KDPF.
KDOC	Komatsu Diesel Oxidation Catalyst	Engine	This is a catalyst that is used for purifying exhaust gas. It is built in to KDPF or assembled with the muffler.
KDPF	Komatsu Diesel Particulate Filter	Engine	This is a component that is used to purify the exhaust gas. KDOC (catalyst) and KCSF (filter to capture soot) are built-in it. It is installed instead of the conventional muffler.
KTCS	Komatsu Traction Control System	Travel and brake (HM)	This is a function that performs braking with the optimum force and recovers the driving force of the wheels by actuating the inter-axle differential lock when the wheels runs idle while the machine travels on the soft ground.
LCD	Liquid Crystal Display	Machine monitor	This is an image display equipment such as a monitor in which the liquid crystal elements are assembled.
LED	Light Emitting Diode	Electronic parts	This is a semiconductor element that emits light when the voltage is applied in forward direction.
LIN	Local Interconnect Network	Communication and electronic control	This is one of communication standards that are used in the network on the machine.
LS	Load Sensing	Hydraulic system	This is a function that detects differential pressure of pump, and controls discharged volume corresponding to load.
LVDS	Low Voltage Differential Signaling	Communication and electronic control	This is one of communication standards that are used in the network on the machine.
MAF	Mass Air Flow	Engine	This indicates engine intake air flow. This is not used independently but is used as combined with sensor. Mass air flow sensor can be called as MAF sensor.

Unit: mm

No.	Item	Criteria		Remedy
4	Outside diameter of cylinder liner (counterbore lower portion)	161.2	+0.090 +0.050	Replace cylinder liner
	Interference of cylinder liner and block (counterbore lower portion)	Standard interference	Allowable interference	Replace cylinder liner or block
0.02 to 0.12		Min. 0.02		
5	Outside diameter of cylinder liner (O-ring portion)	Standard dimension	Tolerance	Replace cylinder liner
		158	-0.073 -0.103	
	Clearance between cylinder liner and block (O-ring portion)	Standard clearance: 0.024 to 0.089		Replace cylinder liner or block
6	Protrusion on the upper surface of cylinder liner	Not crushed or damaged		Replace cylinder liner

MAINTENANCE STANDARD OF TIMING GEAR

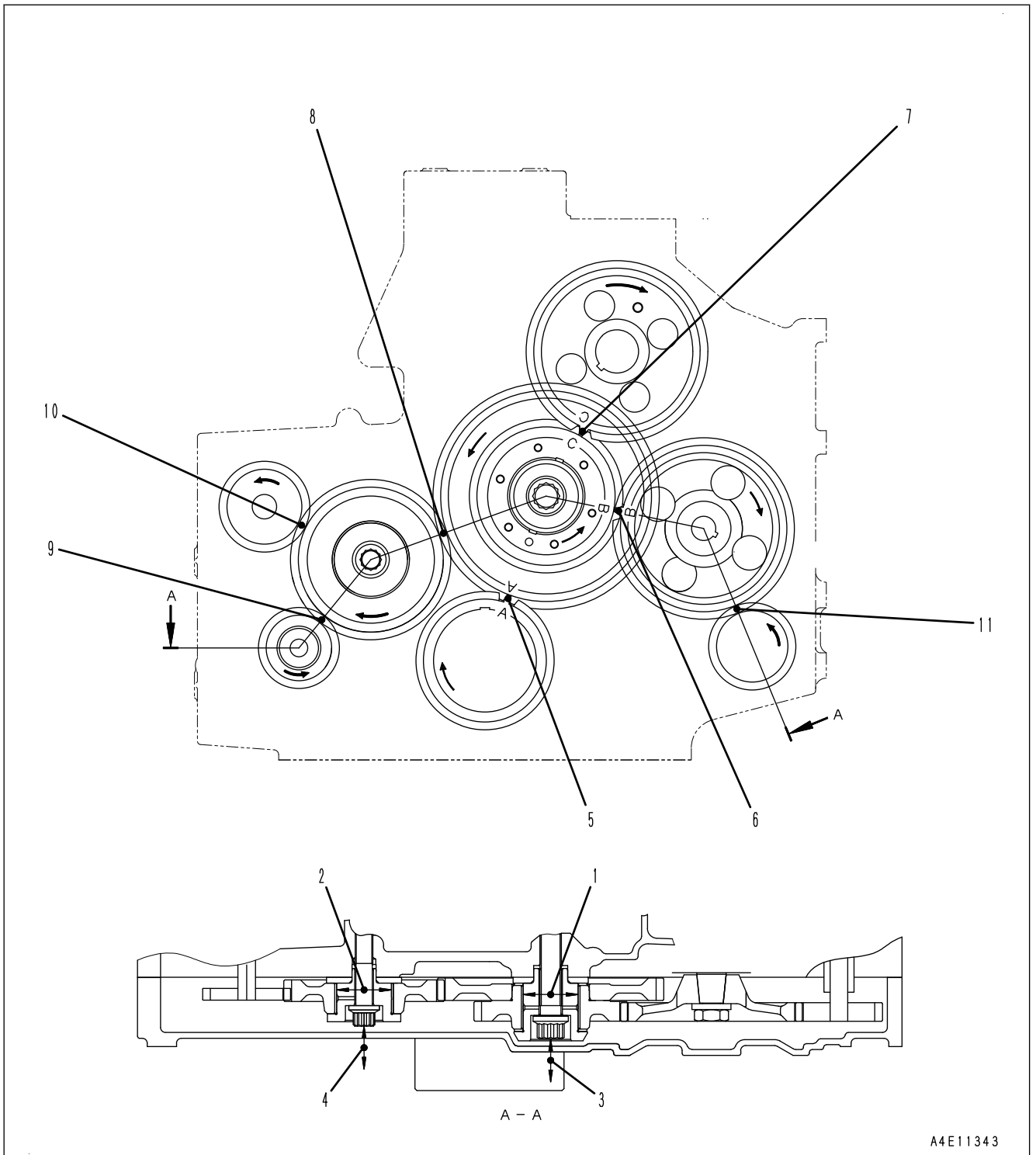

A4E11343

MAINTENANCE STANDARD OF RELIEF VALVE OF ENGINE BOOST OIL PUMP

REMARK

The shape is subject to machine models.

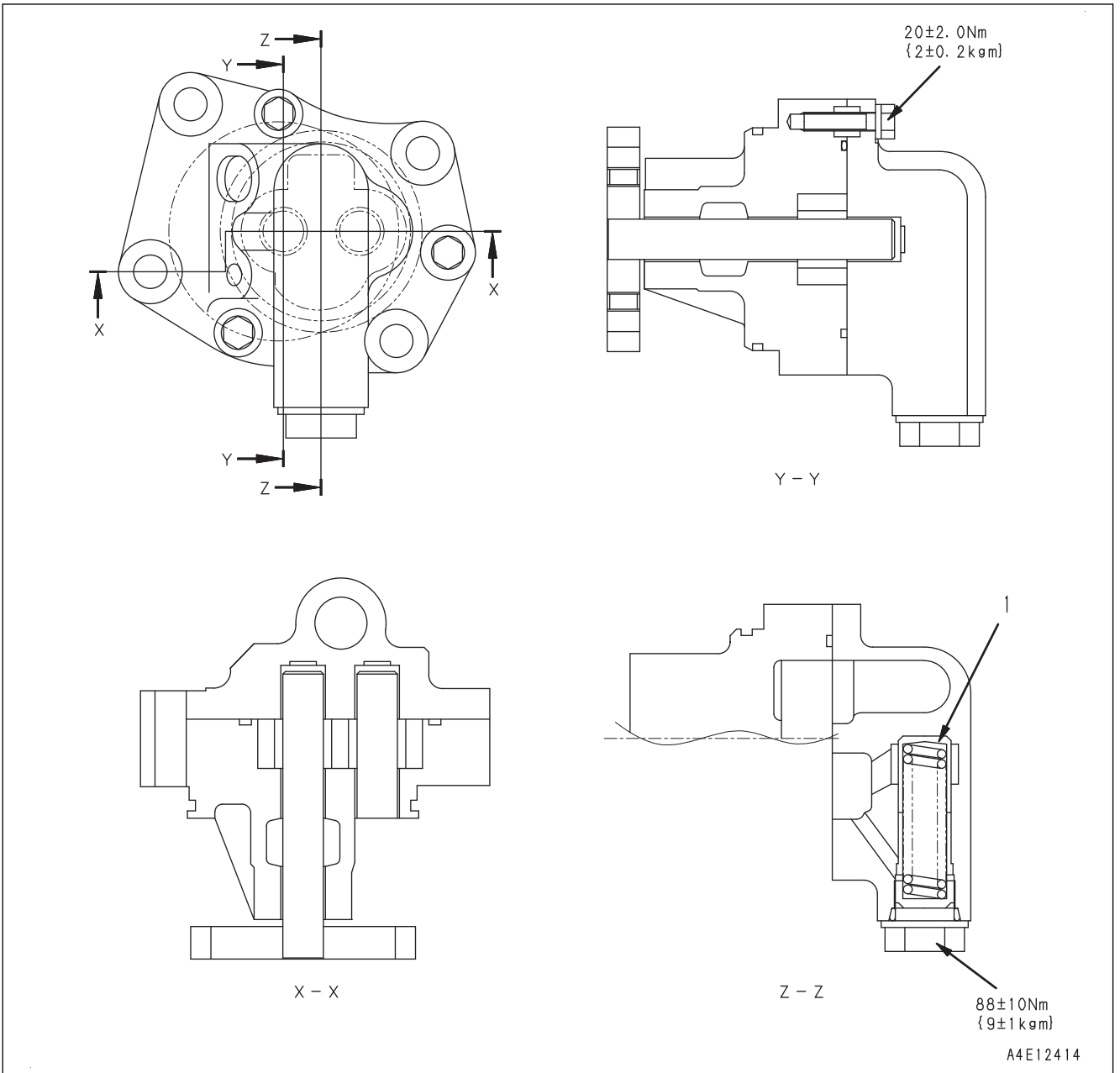

No.	Item	Criteria	Remedy
1	Main relief valve cracking pressure	Standard: $1430 \pm 100 \text{ kPa}$ $\{14.6 \pm 1.0 \text{ kg/cm}^2\}$	Repair or replace spring

CLICK HERE TO **DOWNLOAD** THE COMPLETE MANUAL

- Thank you very much for reading the preview of the manual.
- You can download the complete manual from: www.heydownloads.com by clicking the link below



- Please note: If there is no response to CLICKING the link, please download this PDF first and then click on it.

CLICK HERE TO **DOWNLOAD** THE COMPLETE MANUAL