

SHOP
MANUAL

KOMATSU

125-2 SERIES
DIESEL ENGINE

CLICK HERE TO **DOWNLOAD** THE COMPLETE MANUAL

- Thank you very much for reading the preview of the manual.
- You can download the complete manual from: www.heydownloads.com by clicking the link below



- Please note: If there is no response to CLICKING the link, please download this PDF first and then click on it.

CLICK HERE TO **DOWNLOAD** THE COMPLETE MANUAL

HOISTING INSTRUCTIONS

HOISTING

! Heavy parts (25 kg or more) must be lifted with a hoist, etc. In the **DISASSEMBLY AND ASSEMBLY** section, every part weighing 25 kg or more is indicated clearly with the symbol 

- If a part cannot be smoothly removed from the machine by hoisting, the following checks should be made:
 - 1) Check for removal of all bolts fastening the part to the relative parts.
 - 2) Check for existence of another part causing interference with the part to be removed.

WIRE ROPES

- 1) Use adequate ropes depending on the weight of parts to be hoisted, referring to the table below:

Wire ropes
(Standard "Z" or "S" twist ropes
without galvanizing)

Rope diameter	Allowable load	
	kN	tons
mm		
10	9.8	1.0
11.5	13.7	1.4
12.5	15.7	1.6
14	21.6	2.2
16	27.5	2.8
18	35.3	3.6
20	43.1	4.4
22.4	54.9	5.6
30	98.1	10.0
40	176.5	18.0
50	274.6	28.0
60	392.2	40.0

- ★ The allowable load value is estimated to be one-sixth or one-seventh of the breaking strength of the rope used.
- 2) Sling wire ropes from the middle portion of the hook.

Slinging near the edge of the hook may cause the rope to slip off the hook during hoisting, and a serious accident can result. Hooks have maximum strength at the middle portion.

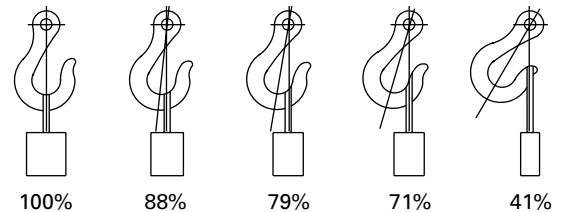

SAD00479

- 3) Do not sling a heavy load with one rope alone, but sling with two or more ropes symmetrically wound onto the load.

! Slinging with one rope may cause turning of the load during hoisting, untwisting of the rope, or slipping of the rope from its original winding position on the load, which can result in a dangerous accident.

- 4) Do not sling a heavy load with ropes forming a wide hanging angle from the hook.

When hoisting a load with two or more ropes, the force subjected to each rope will increase with the hanging angles. The table below shows the variation of allowable load kN {kg} when hoisting is made with two ropes, each of which is allowed to sling up to 9.8 kN {1000 kg} vertically, at various hanging angles. When two ropes sling a load vertically, up to 19.6 kN {2000 kg} of total weight can be suspended. This weight becomes 9.8 kN {1000 kg} when two ropes make a 120° hanging angle. On the other hand, two ropes are subjected to an excessive force as large as 39.2 kN {4000 kg} if they sling a 19.6 kN {2000 kg} load at a lifting angle of 150°.

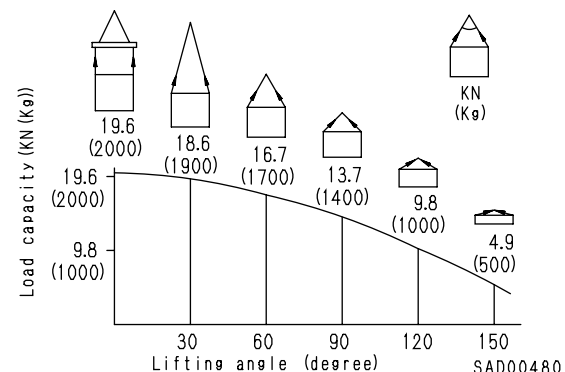

SAD00480

Millimeters to Inches

1 mm = 0.03937 in

	0	1	2	3	4	5	6	7	8	9
0	0	0.039	0.079	0.118	0.157	0.197	0.236	0.276	0.315	0.354
10	0.394	0.433	0.472	0.512	0.551	0.591	0.630	0.669	0.709	0.748
20	0.787	0.827	0.866	0.906	0.945	0.984	1.024	1.063	1.102	1.142
30	1.181	1.220	1.260	1.299	1.339	1.378	1.417	1.457	1.496	1.536
40	1.575	1.614	1.654	1.693	1.732	1.772	1.811	1.850	1.890	1.929
50	1.969	2.008	2.047	2.087	2.126	2.165	2.205	2.244	2.283	2.323
60	2.362	2.402	2.441	2.480	2.520	2.559	2.598	2.638	2.677	2.717
70	2.756	2.795	2.835	2.874	2.913	2.953	2.992	3.032	3.071	3.110
80	3.150	3.189	3.228	3.268	3.307	3.346	3.386	3.425	3.465	3.504
90	3.543	3.583	3.622	3.661	3.701	3.740	3.780	3.819	3.858	3.898

Kilogram to Pound

1 kg = 2.2046 lb

	0	1	2	3	4	5	6	7	8	9
0	0	2.20	4.41	6.61	8.82	11.02	13.23	15.43	17.64	19.84
10	22.05	24.25	26.46	28.66	30.86	33.07	35.27	37.48	39.68	41.89
20	44.09	46.30	48.50	50.71	51.91	55.12	57.32	59.53	61.73	63.93
30	66.14	68.34	70.55	72.75	74.96	77.16	79.37	81.57	83.78	85.98
40	88.18	90.39	92.59	94.80	97.00	99.21	101.41	103.62	105.82	108.03
50	110.23	112.44	114.64	116.85	119.05	121.25	123.46	125.66	127.87	130.07
60	132.28	134.48	136.69	138.89	141.10	143.30	145.51	147.71	149.91	152.12
70	154.32	156.53	158.73	160.94	163.14	165.35	167.55	169.76	171.96	174.17
80	176.37	178.57	180.78	182.98	185.19	187.39	189.60	191.80	194.01	196.21
90	198.42	200.62	202.83	205.03	207.24	209.44	211.64	213.85	216.05	218.26

S6D125-2

D65EX-12, D65P-12 D65PX-12, D60P-12	D75S-5	D85A-21, D85A-21S, D85A-21B, D85A-21D, D85E-21, D85P-21, D85C-21	D85E-SS-2 D85E-SS-2A	D87E-2 D87P-2
--	--------	--	-------------------------	------------------

6 - 125 x 150

11.04 (11,040)

1 - 5 - 3 - 6 - 2 - 4

1,483	1,585	1,451	1,483	1,524
906	900	1,110	906	940
1,545	1,902	1,605	1,545	2,012
-	-	-	-	-
140(188)/1,950 (Net)	152/(203)/2,000 (Net)	168(225)/2,000 (Net)	140(188)/1,950 (Net)	174(233)/2,100 (Net)
981(100)/1,200 (Net)	921(94)/1,500 (Net)	1,020(104)/1,400 (Net)	981(100)/1,200 (Net)	999(102)/1,400 (Net)
2,050 - 2,150	2,150 - 2,250	2,150 - 2,250	2,050 - 2,150	2,250 - 2,250
800 - 850	550 - 650	670 - 720	800 - 850	670 - 720
211 (157)	208 (155)	208 (155)	211 (157)	208 (155)
1,220	1,145	1,370	1,200	1,200
DENSO NB (EP9) type RSV centrifugal, all speed type	BOSCH PE-P (PS3S) type RSV centrifugal, all speed type	BOSCH PE-P (PS3S) type RSV centrifugal, all speed type	DENSO NB (EP9) type RSV centrifugal, all speed type	BOSCH PE-P (PS3000) type RSV centrifugal, all speed type
44 (38)	32 (28)	32 (29)	44 (38)	32 (29)
56 (21)	65 (21)	71 (21)	56 (21)	(21)
24 V, 35 A	24 V, 35 A	24 V, 35 A	24 V, 35 A	24 V, 50 A
24 V, 7.5 kW	24 V, 7.5 kW	24 V, 7.5 kW	24 V, 7.5 kW	24 V, 7.5 kW
12 V 140 Ah x 2	12 V 170 Ah x 2	12 V 170 Ah x 2	12 V 140 Ah x 2	12 V 110 Ah x 2
GARRET TO4E type	SCHWITZER S3A type	SCHWITZER S3A type	GARRET TO4E type	SCHWITZER S3A type
-	-	-	-	-
-	-	-	-	-

615002

SA6D125-2 RIGHT SIDE VIEW [For PC400-6 (CUSTOM), PC400LC-6 (CUSTOM),
PC450-6 (MIGHTY), PC450LC-6 (MIGHTY), BR500JG-1]

615002

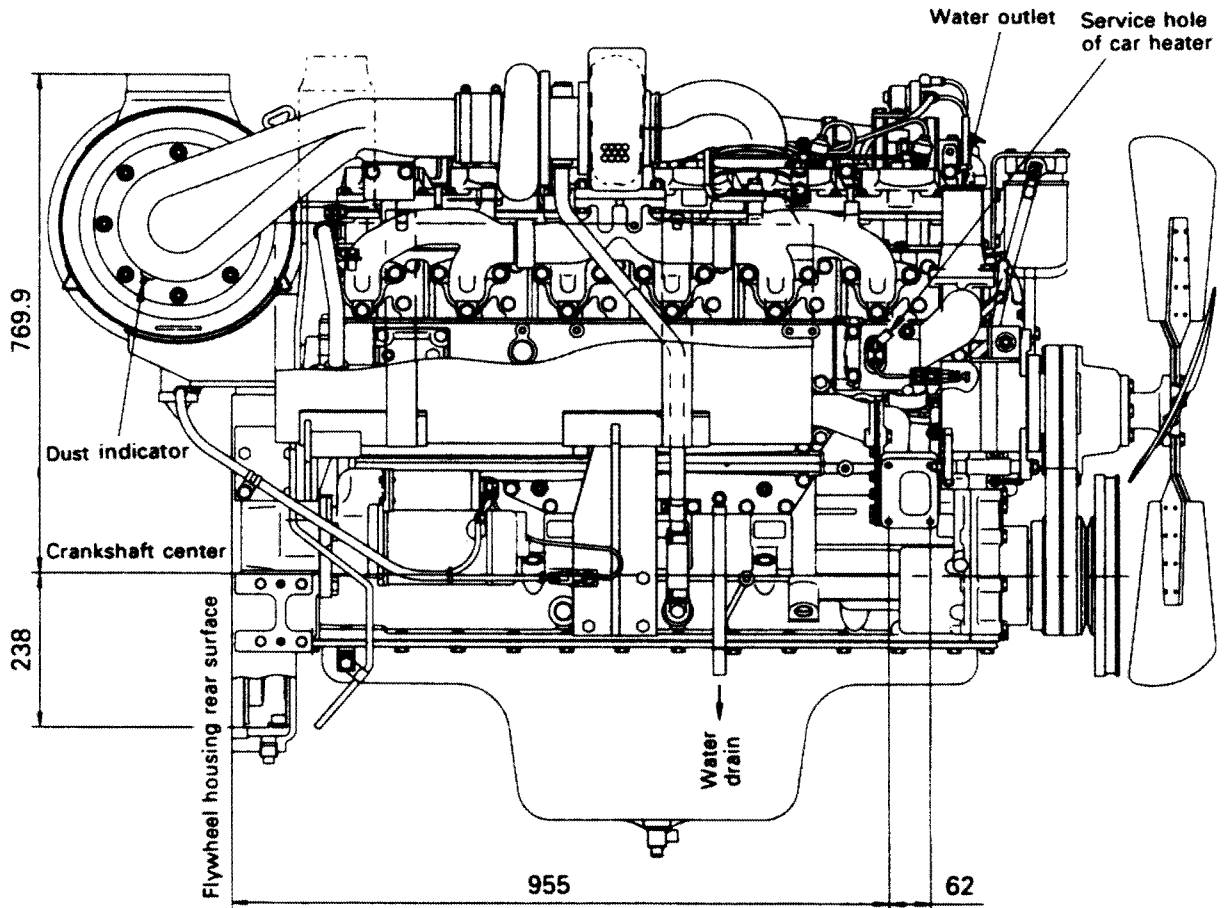

SDE00037

SA6D125-2 FRONT SIDE VIEW [For DCA300SSK (DENYO generator)]

615002

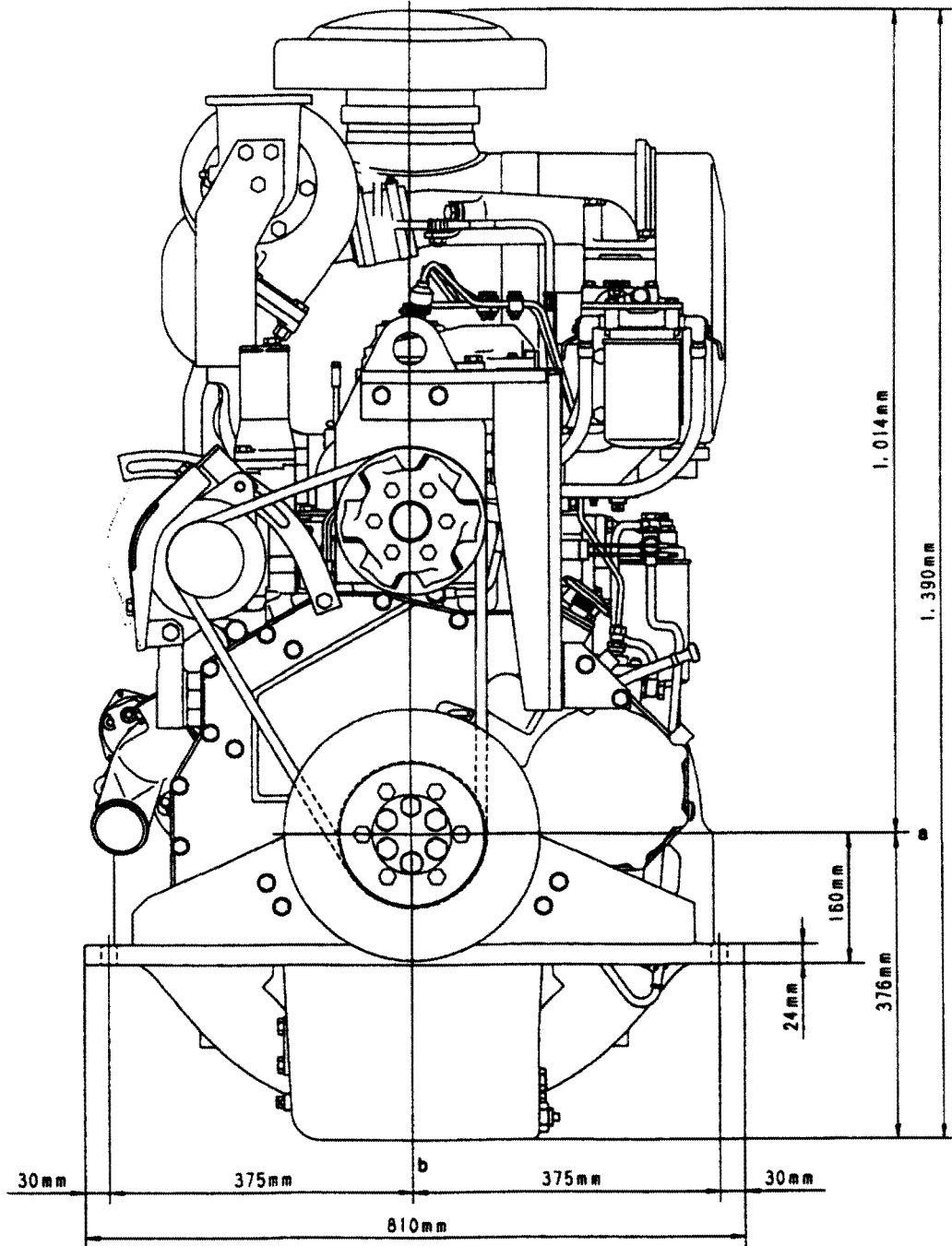

- a. Crankshaft center
- b. Cylinder liner center

SJE01504

6D125-2 (D65E-12, D70LE-12)

Flywheel horsepower: 131 kW (175 HP)/1,950 rpm (Net)

Maximum torque: 799 Nm (81.5 kgm)/1,100 rp (Net)

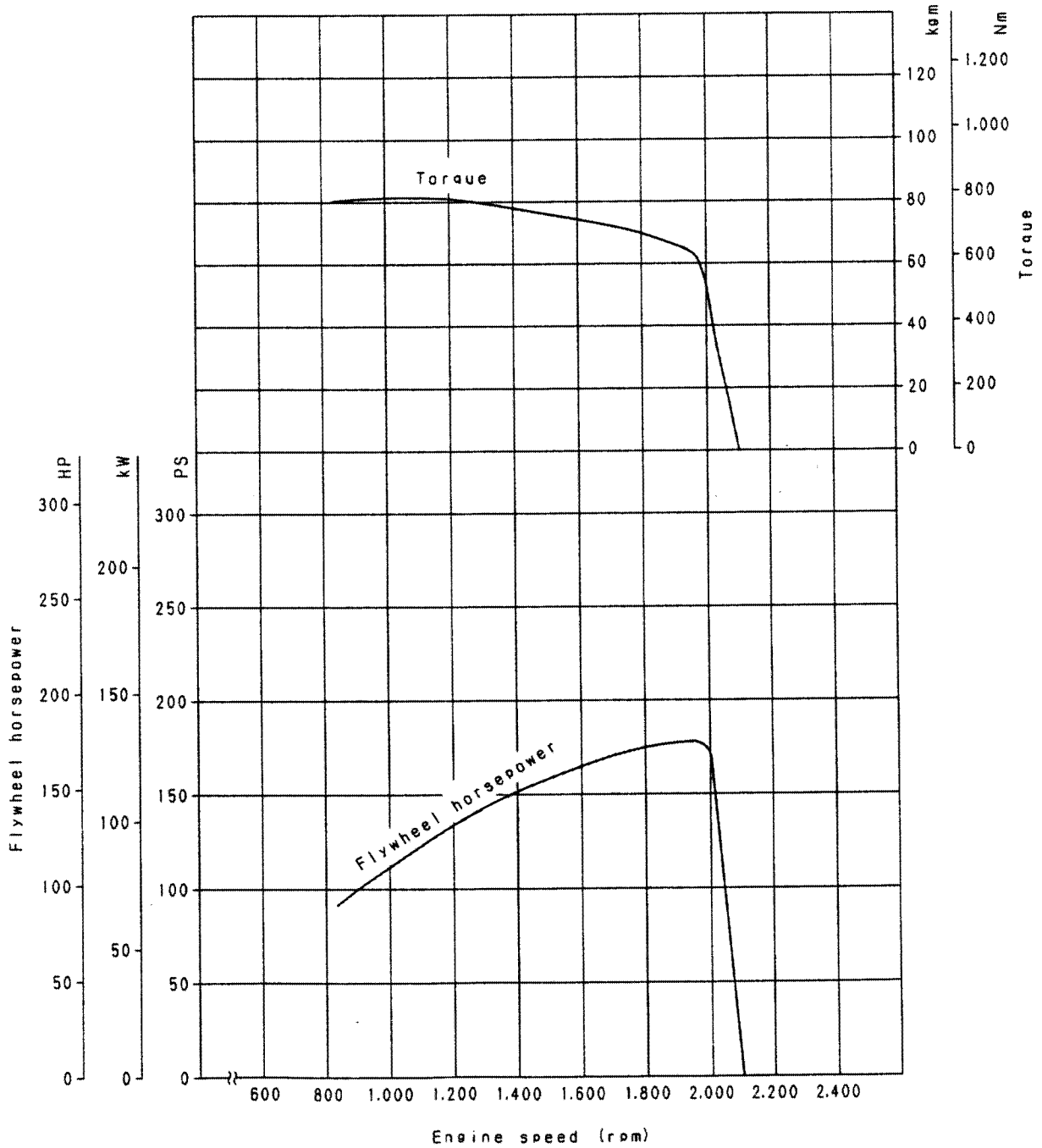

615002

SJE01751

S6D125-2 (For MQ generator DCA-220SSK)

Flywheel horsepower: 204 kW (273 HP)/1,800 rpm (Net, 60 Hz)

615002

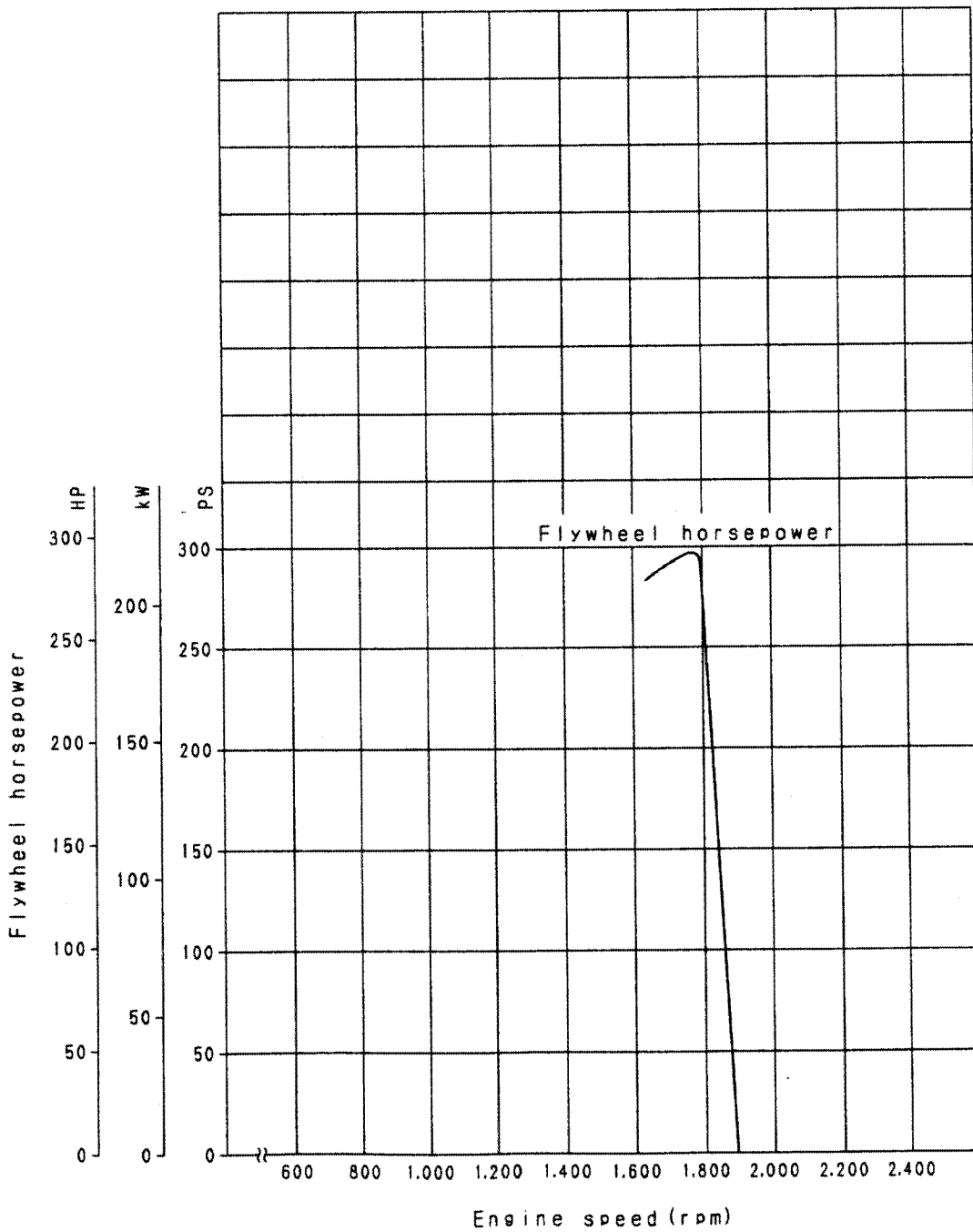

SWE01368

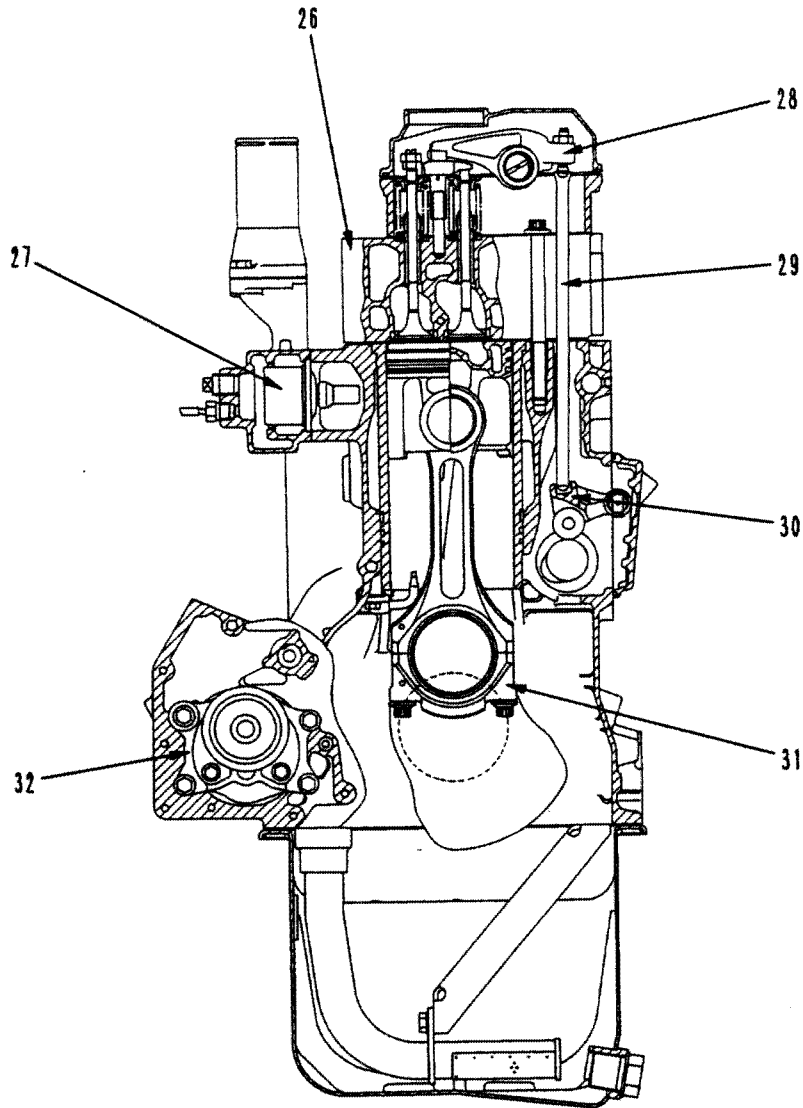

615002

SWE01743

- 26. Cylinder head
- 27. Thermostat
- 28. Rocker arm
- 29. Push rod
- 30. Cam follower
- 31. Connecting rod cap
- 32. Oil pump

Engine: 6D125-2
 S6D125-2 (with turbocharger)
 SA6D125-2 (with turbocharger
 and after-cooler)
 SAA6D125-2 (with turbocharger and
 air cooled after-cooler)

Type: In-line, 6-cylinders, water-cooled, direct
 fuel injection, 4-cycle diesel engine

1

2

3

4

1

2

3

4

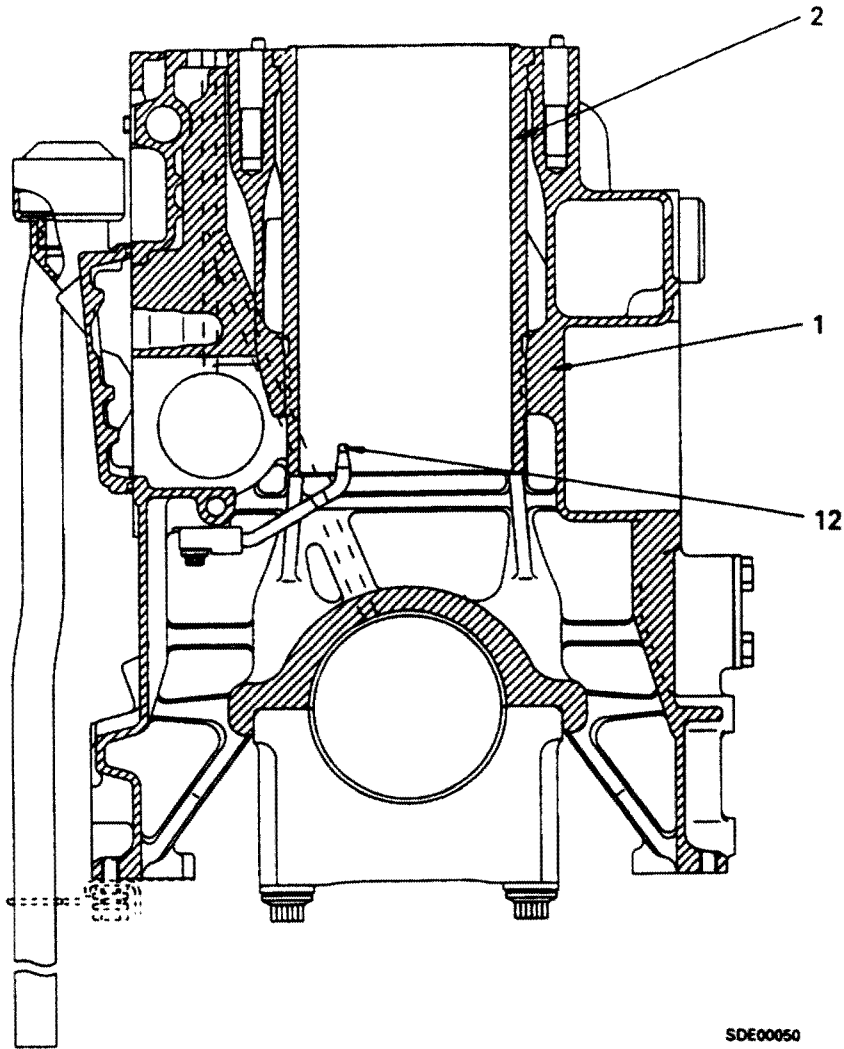

615002

SDE00050

CYLINDER BLOCK

- Crankshaft: 7 bearings
- Camshaft: 7 bearings

FRONT SEAL

- Single lip with dust seal

PISTON COOLING

- With piston cooling nozzle
(S6D125-2, SA6D125-2, SAA6D125-2)

CYLINDER LINER

- Wet type
- Treatment: Plateau honing finish
Gas soft nitriding
(S6D125-2, SA6D125-2,
SAA6D125-2)

LINER SEAL

- Top: Clevis seal
- Middle: O-ring (Ethylene propylene rubber)
- Bottom: O-ring (Silicon rubber)

615002

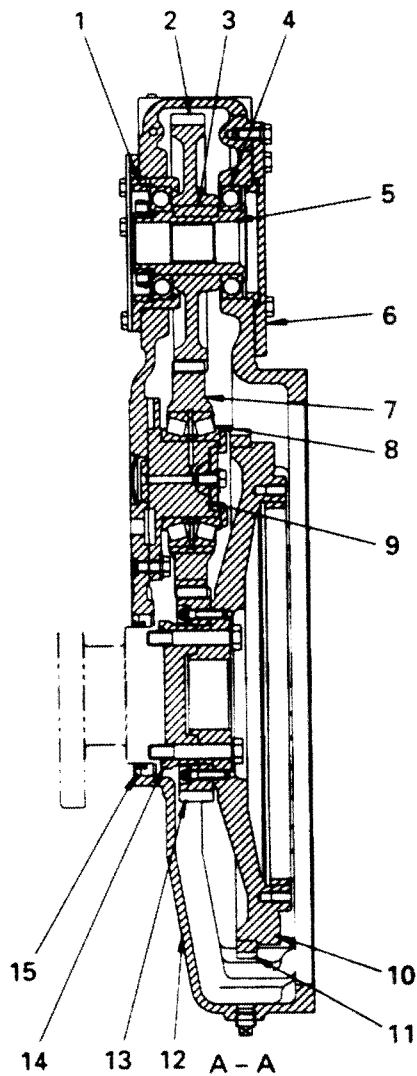

- 1. Bearing case
- 2. PTO drive gear (No. of teeth: 47)
- 3. Key
- 4. Ball bearing
- 5. PTO drive shaft
- 6. PTO cover
- 7. Idler gear
- 8. Roller bearing
- 9. Idler shaft
- 10. Flywheel
- 11. Ring gear
- 12. Flywheel housing
- 13. Crankshaft gear (No. of teeth on PTO drive gear: 39)
- 14. Spacer
- 15. Rear seal
- 16. Pump drive gear (No. of teeth: 46)
- 17. Bearing case
- 18. Cover
- 19. Ball bearing
- 20. Bearing shaft
- 21. Spacer

a. Pump pickup port

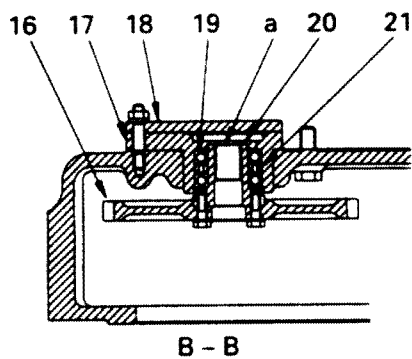

SKE00199

FUEL SYSTEM

FUEL SYSTEM CHART

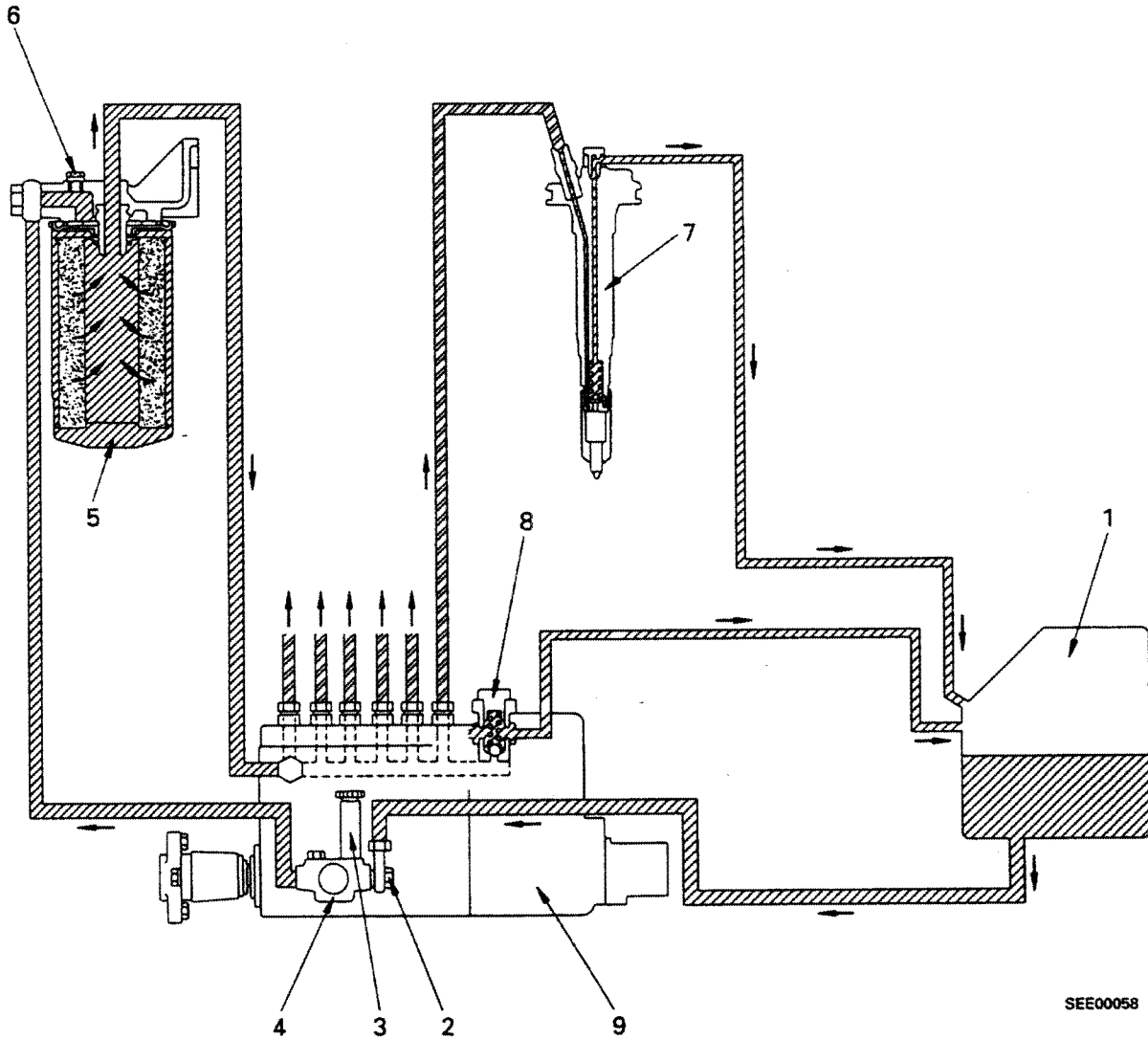

1. Fuel tank
2. Gauze filter
3. Priming pump
4. Feed pump
5. Fuel filter
6. Air bleed plug
7. Fuel injection nozzle
8. Over-flow valve
9. Governor and fuel injection pump

Structural diagram (2)

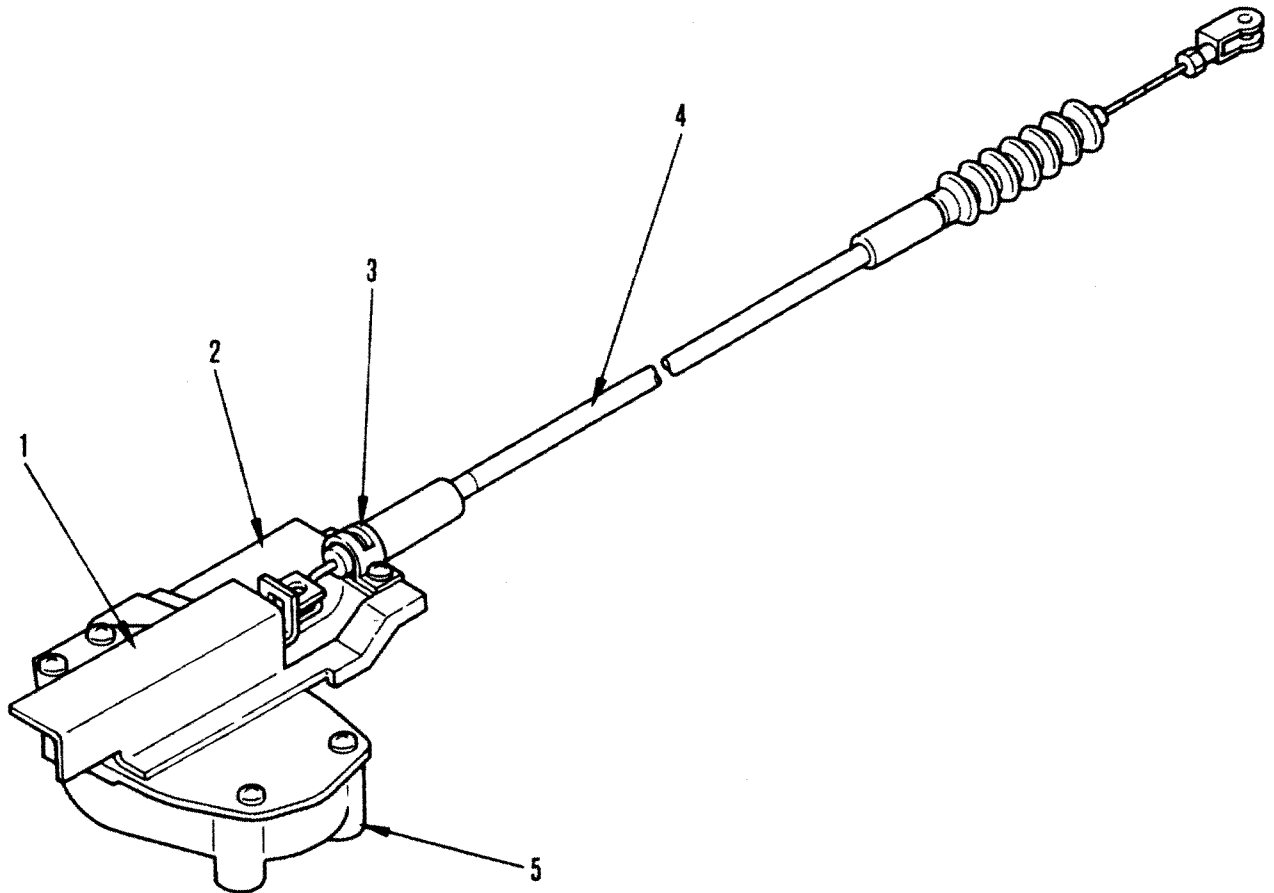

- 1. Gear cover assembly
- 2. Motor assembly
- 3. Cable clamp
- 4. Cable assembly
- 5. Gear case assembly

615002

COOLING SYSTEM

COOLING SYSTEM CHART

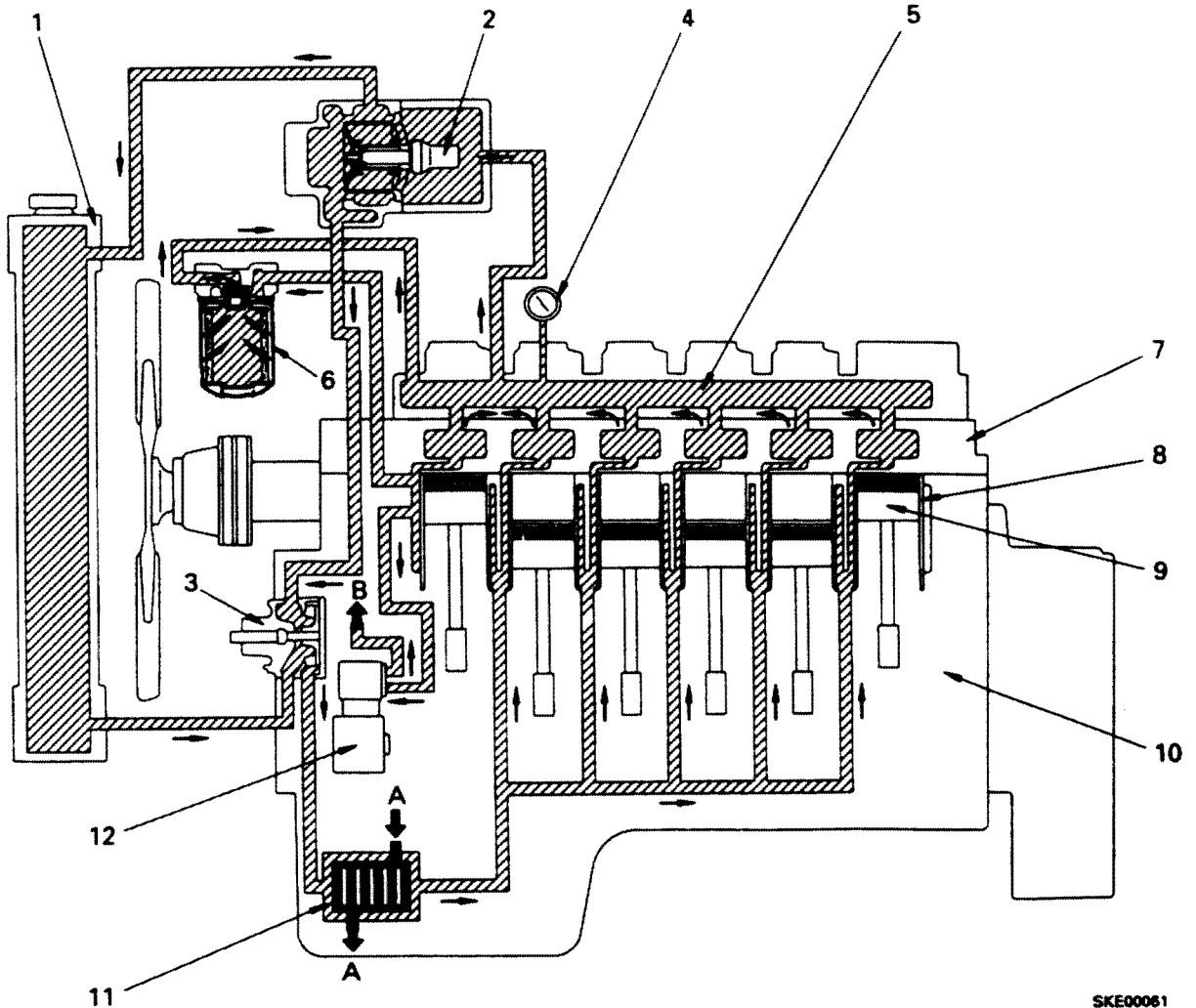

615002

SKE00061

- 1. Radiator
- 2. Thermostat
- 3. Water pump
- 4. Water temperature gauge
- 5. Water manifold (Integrated with cylinder block)
- 6. Corrosion resistor

- 7. Cylinder head
- 8. Cylinder liner
- 9. Piston
- 10. Cylinder block
- 11. Oil cooler
- 12. Air compressor

- A. Lubrication oil
- B. Cooling water (water manifold to cylinder block)

Mounting

SA6D125-2 [PC400-6, PC450-6]

SAA6D125-2 [PC400AC-6, PC400-6 • PC450-6 (USA), BR550JG-1]

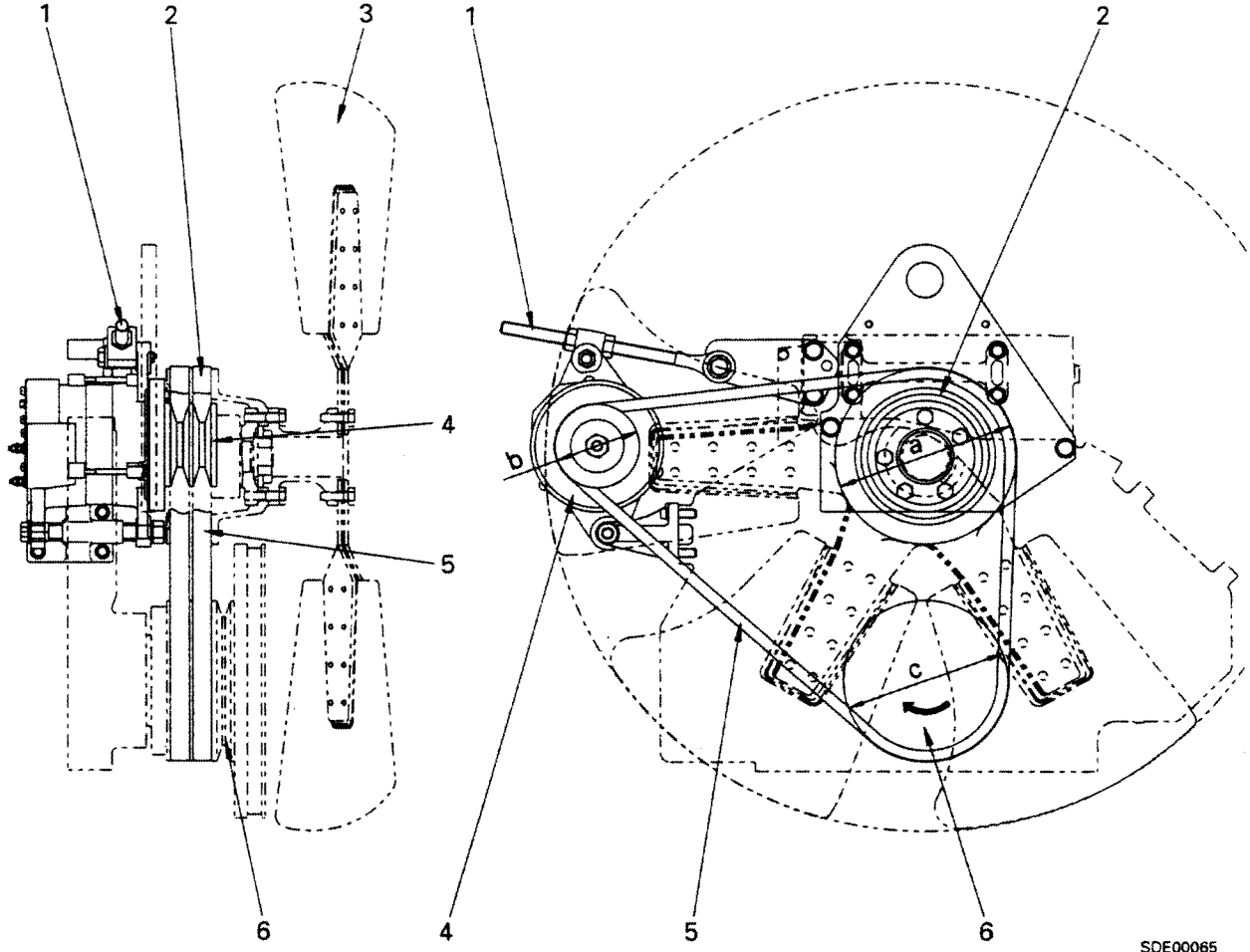

SDE00065

615002

- 1. Adjustment bolt
- 2. Fan pulley
- 3. Fan
- 4. Alternator pulley
- 5. Fan belt
- 6. Crankshaft pulley

- a. Fan pulley O.D.
- b. Alternator pulley O.D.
- c. Crankshaft pulley O.D.

• Pulley O.D.

Engine Model	Applicable machine	Pulley O.D. (mm)		
		a	b	c
SA6D125-2	PC400-6, PC450-6	200	95	182
SAA6D125-2	PC400AC-6 PC400-6 • PC450-6 (USA) BR550JG-1	200	95	182

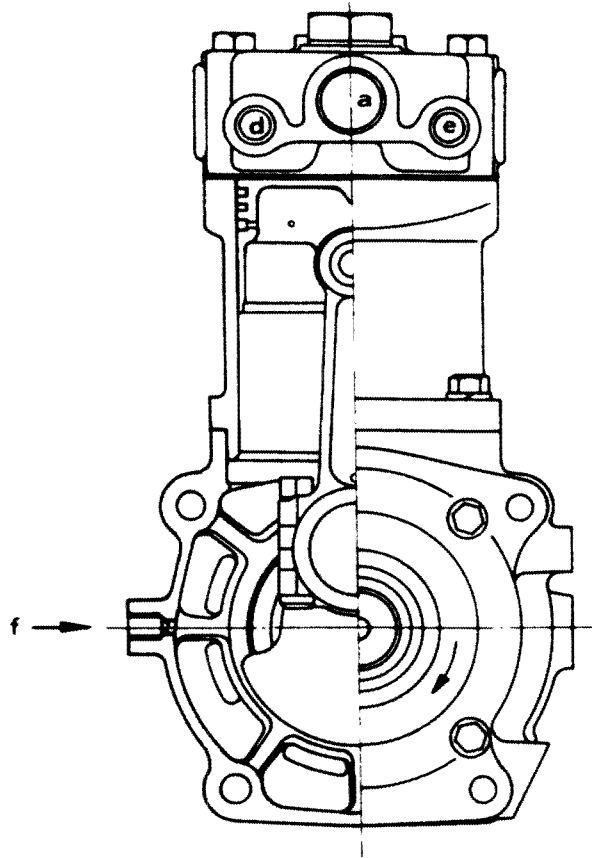

615002

6150F141

AIR COMPRESSOR

- Maker: ZEXEL
- Type: Single cylinder, double acting
- Discharge volume: 340 cc/rev.
- Air pressure: 0.83 MPa (8.5 kg/cm²) (at full load)
- Weight: 11 kg

UNLOADER VALVE

- Valve opening pressure: 0.62 MPa (6.3 kg/cm²)
- Valve shutting pressure: 0.53 MPa (5.4 kg/cm²)

- 6) Check that fuel injection timing line (a) on the fuel injection pump is aligned with line (b) on the fuel injection pump body at the point where the fuel stops flowing.
- ★ BEYOND injection timing line:
Timing RETARDED
 - ★ BEFORE injection timing line:
Timing ADVANCED

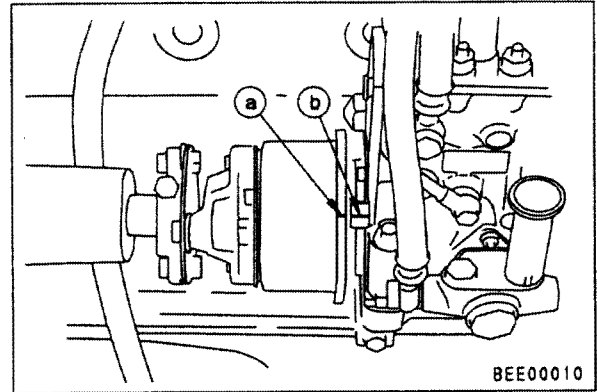

2. Adjusting fuel injection timing with delivery valve method

If the results of the test show that the fuel injection timing is incorrect, adjust the fuel injection timing as follows.

- 1) Disconnect spill tube (1) and delivery tube (2) of the No. 1 piston, then remove No. 1 nozzle holder assembly (3).

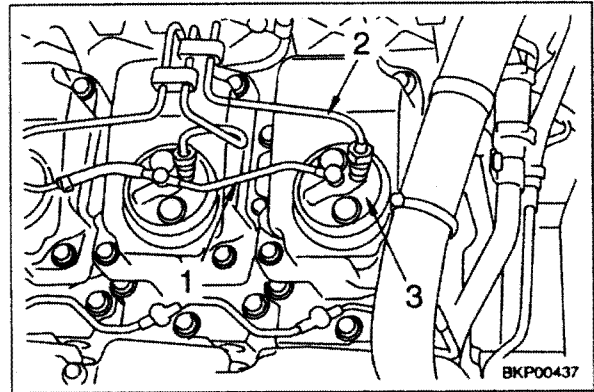

- 2) Align No. 1 cylinder with the compression top dead center line (1 : 6).
- When doing this, check that fuel injection timing line (a) on the fuel injection pump is near line (b) on the fuel injection pump body.

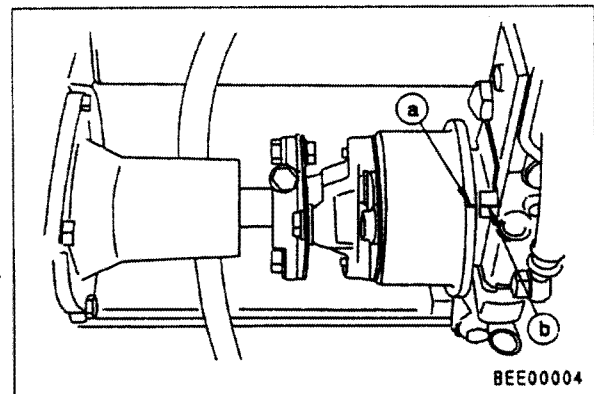

- 3) Set dial gauge P to the nozzle holder hole where the nozzle holder assembly has been removed. (See the diagram.)

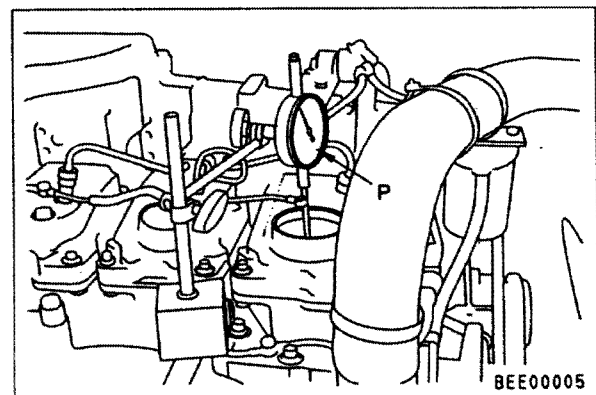

615002

CLICK HERE TO **DOWNLOAD** THE COMPLETE MANUAL

- Thank you very much for reading the preview of the manual.
- You can download the complete manual from: www.heydownloads.com by clicking the link below



- Please note: If there is no response to CLICKING the link, please download this PDF first and then click on it.

CLICK HERE TO **DOWNLOAD** THE COMPLETE MANUAL

(CALIBRATION DATA)

Injection Pump Assembly Number
6150-72-1220 (092000-1650)

(): Injection pump manufacturer's part No.

Injection Pump Type	Injection pump Manufacturer
NB(EP9)	DENSO

Applicable Machine		Applicable Engine	
Model	Serial No.	Model	Serial No.
D53A-17, D53P-17 D58E-1, D58P-1		6D125-2	

Injection pump specification

Rotating direction	Counterclockwise
Injection order	1 - 5 - 3 - 6 - 2 - 4
Injection interval	59°30' - 60°30'
Plunger pre-stroke (mm)	4.2
Delivery valve (mm ³ /st) retraction volume	90

Engine Specification

Flywheel horsepower (kW (HP)) / rpm	104 (140)/1,900 (Gross)
Maximum torque (Nm (kgm)/ rpm)	650 (66.3)/1,300 (Gross)
High idling speed (rpm)	2,050 - 2,150
Low idling speed (rpm)	800 - 850
Pump tester capacity for Service standard	Motor 7.5 kW

Calibration Standard

(): Injection pump manufacturer's part number

Conditions	Service standard		Manufacturer standard	
	Nozzle & nozzle holder part No.	(093500-8080)	(093500-6080)	
Nozzle part No.	(093400-0540)	(093400-3010)		
Nozzle holder part No.	(093100-0190)	(093100-6080)		
Injection pipe (mm) (Outside dia. x inside dia. x length)	6 x 2 x 600		6 x 2 x 747	
Test oil	ASTM D975 No. 2 diesel fuel or equivalent			
Oil temperature (°C)	40 to 45			
Nozzle opening pressure (MPa(kg/cm ²))	17.2 (175)		24.5 (250)	
Transfer pump pressure (kPa(kg/cm ²))	157 (1.6)		157 (1.6)	

Injection volume	Rack point	Rack position (mm)	Pump speed (rpm)	Service standard (cc/1000 st.)		Manufacturer standard (cc/ st.)	
				Injection volume	Maximum variance between cylinder	Injection volume	Maximum variance between cylinder
<ul style="list-style-type: none"> • Rack positions B to E are the reference volume when adjusting the injection volume. • Marks ★ are average volumes. 	A (Basic point)	10.6	950	★95 - 101	8		
	B	8.5	440	★10 - 14	5		
	C						
	D						
	E						

Governor performance curve

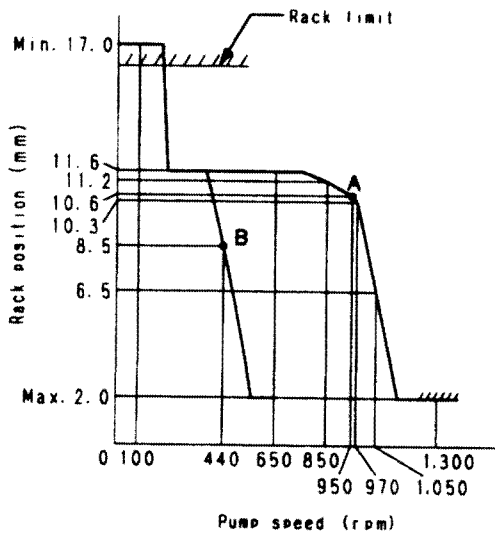

TWE00856

615002

(CALIBRATION DATA)

Injection Pump Assembly Number
6151-72-1390 (106692-9280)

(): Injection pump manufacturer's part No.

Injection Pump Type	Injection pump Manufacturer
PE-A(PS3S)	ZEXEL

Applicable Machine		Applicable Engine	
Model	Serial No.	Model	Serial No.
EG220BS-2 DCA220SPK (DENYO generator)		S6D125-2	

Injection pump specification

Rotating direction	Counterclockwise
Injection order	1 - 5 - 3 - 6 - 2 - 4
Injection interval	59°30' - 60°30'
Plunger pre-stroke (mm)	3.55 - 3.65
Delivery valve (mm ³ /st) retraction volume	90

Engine Specification

Flywheel horsepower (kW (HP)) / rpm	181 (243)/1,500 (50 Hz, Gross) 209 (280)/1,800 (60 Hz, Gross)
Maximum torque (Nm (kgm)) / rpm	-
High idling speed (rpm)	max. 1,567 (50 Hz) max. 1,880 (60 Hz)
Low idling speed (rpm)	700 - 800
Pump tester capacity for Service standard	Motor 7.5 kW

Calibration Standard

(): Injection pump manufacturer's part number

Conditions	Service standard		Manufacturer standard				
	<ul style="list-style-type: none"> Service standard indicates data using calibration test parts. Manufacturer standard is data for factory test. 	Nozzle & nozzle holder part No.	(105780-8140)	6151-12-3300 (105111-4570)			
Nozzle part No.		(105780-2080)	6151-12-3320 (105025-0690)				
Nozzle holder part No.		(105780-0000)	6152-12-3110 (105041-7130)				
Injection pipe (mm) (Outside dia. x inside dia. x length)		8 x 3 x 600	6 x 2.2 x 720				
Test oil		ASTM D975 No. 2 diesel fuel or equivalent					
Oil temperature (°C)		40 to 50					
Nozzle opening pressure (MPa(kg/cm ²))		17.2 (175)	24.5 (250)				
Transfer pump pressure (kPa(kg/cm ²))		157 (1.6)	157 (1.6)				
Injection volume	Rack point	Rack position (mm)	Pump speed (rpm)	Service standard (cc/1000 st.)		Manufacturer standard (cc/1000 st.)	
				Injection volume	Maximum variance between cylinder	Injection volume	Maximum variance between cylinder
<ul style="list-style-type: none"> Rack positions B to E are the reference volume when adjusting the injection volume. Marks * are average volumes. 	A (Basic point)	10.3	750	*208 - 212	±3	*230	
	B	approx. 5.9	375	*13.5 - 16.5	±15	*15	
	C						
	D						
	E						

Governor performance curve

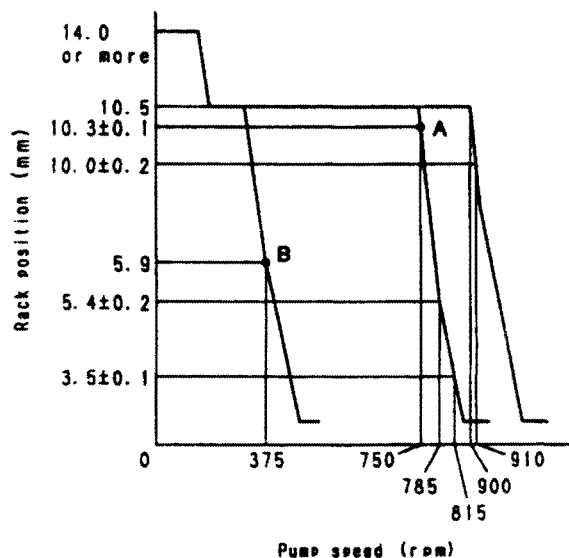

Pump speed (rpm) TWE00591

615002

(CALIBRATION DATA)

Injection Pump Assembly Number
6151-72-1570 (106692-9360)

(): Injection pump manufacturer's part No.

Injection Pump Type	Injection pump Manufacturer
PE-P(PS3000)	BOSCH

Applicable Machine		Applicable Engine	
Model	Serial No.	Model	Serial No.
CS210-1		S6D125-2	

Injection pump specification

Rotating direction	Counterclockwise
Injection order	1 - 5 - 3 - 6 - 2 - 4
Injection interval	60° ± 30'
Plunger pre-stroke (mm)	3.75 ± 0.75
Delivery valve (mm ³ /st) retraction volume	60

Engine Specification

Flywheel horsepower (kW {HP}) / rpm	163 {218}/2,000 (Gross)
Maximum torque (Nm {kgm}/ rpm)	954 {97.3}/1,300 (Gross)
High idling speed (rpm)	2,200 ± 50
Low idling speed (rpm)	650 ⁺⁵⁰ ₀
Pump tester capacity for Service standard	Motor 7.5 kW

Calibration Standard

(): Injection pump manufacturer's part number

Conditions	Service standard		Manufacturer standard	
	<ul style="list-style-type: none"> ● Service standard indicates data using calibration test parts. ● Manufacturer standard is data for factory test. 	Nozzle & nozzle holder part No.	(105780-8140)	6151-12-3400 (105111-4600)
	Nozzle part No.	(105780-0000)	6151-12-3420 (105025-0750)	
	Nozzle holder part No.	(105780-2080)	6152-12-3110 (105041-7130)	
	Injection pipe (mm) (Outside dia. x inside dia. x length)	8 x 3 x 600	6 x 2.2 x 720	
	Test oil	ASTM D975 No. 2 diesel fuel or equivalent		
	Oil temperature (°C)	40 to 45		
	Nozzle opening pressure (MPa{kg/cm ² })	17.2 {175}	24.5 {250}	
	Transfer pump pressure (kPa{kg/cm ² })	157 {1.6}	157 {1.6}	

Injection volume	Rack point	Rack position (mm)	Pump speed (rpm)	Service standard (cc/1000 st.)		Manufacturer standard (cc/1000 st.)	
				Injection volume	Maximum variance between cylinder	Injection volume	Maximum variance between cylinder
<ul style="list-style-type: none"> ● Rack positions B to E are the reference volume when adjusting the injection volume. ● Marks ★ are average volumes. 	A (Basic point)	8.6	1,000	★ 114 ± 2	±3	★ 133	-
	B	8.6	650	★ 132 ± 3	±4	★ 147.5	-
	C	Approx. 6.0	325	★ 15 ± 1.5	±15	★ 15	-
	E	-	100	★ 145 ⁺²⁰ ₀	-	★ 150	-

Governor performance curve

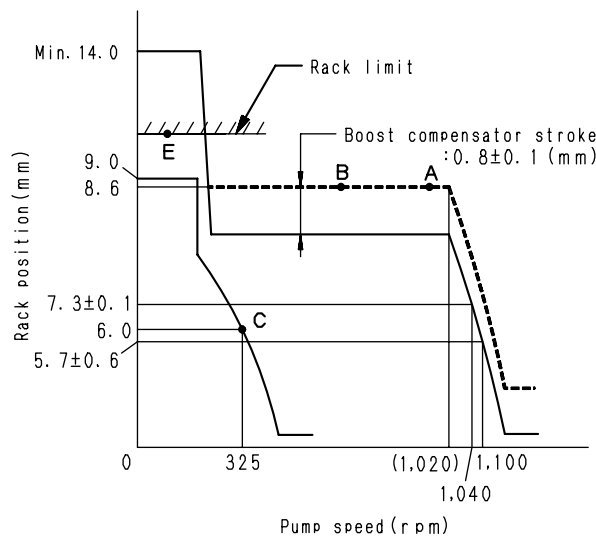

Boost compensator performance curve

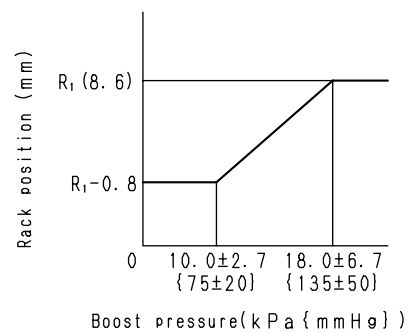

TJE01353

615002

615002

- ★ The table gives the standard values for machines without fan.
- ★ The loads for the dynamometer are at an arm's length of 716 mm.

Engine model	Applicable machine	Item		Order					
				1	2	3	4	5	6
SAA6D125-2	PC400AC-6 PC400-6 (USA) PC450-6 (USA) BR550JG-1	Running time	min.	2	8	2	3	5	
		Engine speed	rpm	700	1,000	1,200	1,500	2,050	
		Load	N (kg)	0 (0)	314 (32)	785 (80)	1,260 (128)	1,570 (160)	
		Flywheel horsepower	kW (HP)	0 (0)	23.5 (32)	71 (95)	141 (189)	241 (323)	
	Generator (50 Hz only)	Running time	min.	2	8	2	3	5	
		Engine speed	rpm	700 – 800	1,000	1,200	1,500	1,500	
		Load	N (kg)	0 (0)	548 (56)	1,360 (139)	2,180 (222)	2,720 (278)	
		Flywheel horsepower	kW (HP)	0 (0)	41.2 (56)	123 (167)	245 (333)	307 (417)	
	SAA6D125 -P400	Running time	min.	2	8	2	3	5	
		Engine speed	rpm	650 – 850	1,000	1,200	1,500	1,800	
		Load	N (kg)	0 (0)	392 (40)	980 (100)	1,568 (160)	1,960 (200)	
		Flywheel horsepower	kW (HP)	0 (0)	29(39)	98 (118)	177 (237)	265 (355)	

615002

TROUBLESHOOTING

Points to remember when troubleshooting	12-103
Method of using troubleshooting chart	12-104
S- 1 Starting performance is poor (Starting always takes time)	12-108
S- 2 Engine does not start	12-109
(1) Engine does not turn	12-109
(2) Engine turns but no exhaust gas comes out (Fuel is not being injected)	12-110
(3) Exhaust gas comes out but engine does not start (Fuel is being injected)	12-111
S- 3 Engine does not pick up smoothly (Follow-up is poor)	12-112
S- 4 Engine stops during operations	12-113
S- 5 Engine does not rotate smoothly (hunting)	12-114
S- 6 Engine lacks output (no power)	12-115
S- 7 Exhaust gas is black (incomplete combustion)	12-116
S- 8 Oil consumption is excessive (or exhaust gas is blue)	12-117
S- 9 Oil becomes contaminated quickly	12-118
S-10 Fuel consumption is excessive	12-119
S-11 Oil is in cooling water, or water spurts back, or water level goes down	12-120
S-12 Oil pressure lamp lights up (drop in oil pressure)	12-121
S-13 Oil level rises	12-122
S-14 Water temperature becomes too high (overheating)	12-123
S-15 Abnormal noise is made	12-124
S-16 Vibration is excessive	12-125

615002

**(3) Exhaust gas comes out but engine does not start
(Fuel is being injected)**

General causes why exhaust gas comes out but engine does not start

- Lack of rotating force due to defective electrical system
- Insufficient supply of fuel
- Insufficient intake of air
- Improper selection of fuel

Legend

- : Possible causes (judging from Questions and check items)
- : Most probable causes (judging from Questions and Check items)
- △ : Possible causes due to length of use (used for a long period)
- : Items to confirm the cause.

Causes									
Defective, broken valve system (valve, rocker lever, etc.)									
Defective injection pump (rack, plunger, etc.)									
Worn piston ring, cylinder liner									
Clogged fuel filter, strainer									
Clogged feed pump strainer									
Defective air cleaner element									
Defective intake heater (ribbon heater type)									
Leakage, clogging, air in fuel system									
Clogged injection nozzle									
Clogged injection nozzle, defective spray									
Improper fuel used									

	Confirm recent repair history	Causes										
		Defective, broken valve system (valve, rocker lever, etc.)	Defective injection pump (rack, plunger, etc.)	Worn piston ring, cylinder liner	Clogged fuel filter, strainer	Clogged feed pump strainer	Defective air cleaner element	Defective intake heater (ribbon heater type)	Leakage, clogging, air in fuel system	Clogged injection nozzle	Clogged injection nozzle, defective spray	Improper fuel used
Questions	Degree of use											
	Operated for long period			△	△	△					△	
	Suddenly failed to start	○	○									
	When engine is cranked, abnormal noise is heard from around cylinder head	○										
	Engine oil must be added more frequently			○								
	Non-specified fuel has been used		○							○		
	Replacement of filters has not been carried out according to operation manual				○	○	○					
	Rust is found when fuel is drained			○	○							
	Dust indicator is red					○						
	Indicator lamp does not light up						○					
Check items	Starting motor cranks engine slowly							○				
	Mud is stuck to fuel tank cap									○		
	When fuel lever is placed at FULL position, it does not contact stopper		○									
	When engine is cranked with starting motor, 1) Little fuel comes out even when injection pipe sleeve nut is loosened		○									
	2) Little fuel comes out even when fuel filter air bleed plug is loosened			○	○						○	
	There is leakage from fuel piping								○			
	When exhaust manifold is touched immediately after starting engine, temperature of some cylinder is low									○		
	When fuel filter is drained, no fuel comes out											○

	Remove head cover and check directly	Causes										
		Defective, broken valve system (valve, rocker lever, etc.)	Defective injection pump (rack, plunger, etc.)	Worn piston ring, cylinder liner	Clogged fuel filter, strainer	Clogged feed pump strainer	Defective air cleaner element	Defective intake heater (ribbon heater type)	Leakage, clogging, air in fuel system	Clogged injection nozzle	Clogged injection nozzle, defective spray	Improper fuel used
Troubleshooting	When control rack is pushed, it is found to be heavy, or does not return	●										
	When compression pressure is measured, it is found to be low		●									
	When fuel filter, strainer are inspected directly, they are found to be clogged			●								●
	When feed pump strainer is inspected directly, it is found to be clogged				●							
	When air cleaner element is inspected directly, it is found to be clogged					●						
	Heater mount does not become warm						●					
	Either specific gravity of electrolyte or voltage of battery is low							●				
	When feed pump is operated, there is no response, or pump is heavy								●			
	Stop fuel injection to one cylinder at a time. If there is no change in engine speed, that cylinder is not working									●		
	When fuel cap is inspected directly, it is found to be clogged										●	
Remedy	Replace	Replace	Replace	Clean	Clean	Clean	Repair	Replace	Repair	Clean	Clean	

615002

S-12 Oil pressure lamp lights up (drop in oil pressure)

General causes why oil pressure lamp lights up

- Leakage, clogging, wear of lubricating system
- Defective oil pressure control
- Improper oil used (improper viscosity)
- Deterioration of oil due to overheating

Standards for engine oil selection

Type of oil	Selection of oil SAE number according to ambient temperature								
	-22 -30	-4 -20	14 -10	32 0	50 10	68 20	86 30	104 40	122°F 50°C
Engine oil									
									SAE 30
									SAE 10W
									SAE 10W-30
								SAE 15W-40	

Causes
Clogged oil filter
Worn bearing journal
Clogged strainer
Broken oil pan inside oil pan
Broken suction pipe inside oil pan
Defective oil pump
Insufficient oil in oil pan
Defective regulator valve
Defective relief valve
Leaking, crushed hydraulic piping
Defective oil level sensor
Defective oil pressure sensor
Water, fuel in oil

Legend

- : Possible causes (judging from Questions and check items)
- : Most probable causes (judging from Questions and Check items)
- △ : Possible causes due to length of use (used for a long period)
- ▲ : Items to confirm the cause.

Questions	Confirm recent repair history																					
	Degree of use	Operated for long period	▲	▲																		
Questions	Replacement of filter has not been carried out according to operation manual		○																			
	Caution lamp lights up		○																			
	Non-specified fuel has been used		○	○																		
	Condition when oil pressure lamp lights up	Lights up at low idling		○																		
		Lights up at low, high idling				○	○	○	○	○	○	○	○									
Lights up on slopes												○										
Sometimes lights up																				○	○	
Check items	There is clogging, leakage from hydraulic piping (external)																					
	Oil level sensor lamp lights up																					
	When oil level in oil pan is checked, it is found to be low																					
	Metal particles are found when oil is drained			○																		
	Metal particles are stuck to oil filter element			○																		
Troubleshooting	Oil is cloudy white or smells of diesel oil																					○
	When oil filter is inspected directly, it is found to be clogged			●	●																	
	Remove oil pan and check directly					●	●	●														
	Oil pump rotation is heavy, there is play																					
	There is catching of relief valve, regulator valve, spring, or valve guide is broken																					
When oil level sensor is replaced, oil pressure sensor lamp goes out																						●
When oil pressure is measured, it is found to be within standard value																						●
Remedy			Clean	Clean	Clean	Clean	Repair	Replace	Add	Adjust	Adjust	Adjust	Repair	Replace	Replace							

Carry out troubleshooting for "Oil level" first

615002

S6D125-2

D75S-5		D85A-21, 21S, 21B, 21D, D85E, P, C-21		D85E-SS-2, -2A		D87E-2 D87P-2	
Standard value	Permissible value	Standard value	Permissible value	Standard value	Permissible value	Standard value	Permissible value
2,150 - 2,250	2,150 - 2,250	2,150 - 2,250	2,150 - 2,250	2,050 - 2,150	2,050 - 2,150	2,250 - 2,350	2,250 - 2,350
550 - 650	550 - 650	670 - 720	670 - 720	800 - 850	800 - 85	670 - 720	670 - 720
Min. 100	-	Min. 100	-	Min. 100	-	Min. 100	-
Min. 85	-	Min. 85	-	Min. 85	-	Min. 85	-
Max. 2.94 {300}	7.47 {762}	Max. 2.94 {300}	7.47 {762}	Max. 2.94 {300}	7.47 {762}	Max. 2.94 {300}	7.47 {762}
Min. 66.7 {500}	-	Min. 80.0 {600}	-	Min. 80.0 {600}	64.0 {480}	Min. 80.0 {600}	-
Min. 53.3 {400}	-	Min. 66.7 {500}	-	Min. 66.5 {500}	53.3 {400}	Min. 66.7 {500}	-
Max. 600	700	Max. 650	700	Max. 650	700	Max. 650	700
Max. 4.5	5.5	Max. 5.5	7.0	Max. 5.5	7.0	Max. 5.5	7.0
Max. 1.5	2.5	Max. 2.0	3.0	Max. 2.0	3.0	Max. 2.0	3.0
Max. 1.0	2.0	Max. 2.0	3.0	Max. 2.0	3.0	Max. 2.0	3.0
0.33	-	0.33	-	0.33	-	0.33	-
0.71	-	0.71	-	0.71	-	0.71	-
Min. 2.9 {30}	2.0 {20}	Min. 2.9 {30}	2.0 {20}	Min. 3.3 {34}	2.4 {24}	Min. 2.9 {30}	2.0 {20}
Max. 80	160	Max. 100	200	Max. 50	100	Max. 100	200
0.29 - 0.49 {3.0 - 5.0}	0.21 {2.1}	0.29 - 0.49 {3.0 - 5.0}	0.21 {2.1}	0.29 - 0.49 {3.0 - 5.0}	0.21 {2.1}	0.29 - 0.49 {3.0 - 5.0}	0.21 {2.1}
0.25 - 0.44 {2.5 - 4.5}	0.18 {1.8}	0.25 - 0.44 {2.5 - 4.5}	0.18 {1.8}	0.25 - 0.44 {2.5 - 4.5}	0.18 {1.8}	0.25 - 0.44 {2.5 - 4.5}	0.18 {1.8}
Min. 0.15 {1.5}	0.08 {0.8}	Min. 0.15 {1.5}	0.07 {0.7}	Min. 0.15 {1.5}	0.08 {0.8}	Min. 0.15 {1.5}	0.08 {0.8}
Min. 0.10 {1.0}	0.07 {0.7}	Min. 0.10 {1.0}	0.07 {0.7}	Min. 0.10 {1.0}	0.07 {0.7}	Min. 0.10 {1.0}	0.07 {0.7}
90 - 110	120	90 - 110	120	90 - 110	120	90 - 110	120
Max. 0.5	1.0	Max. 0.5	1.0	Max. 0.5	1.0	Max. 0.5	1.0
25.0 - 26.0 {255 - 265}	20.1 {205}	25.0 - 26.0 {255 - 265}	20.1 {205}	25.0 - 26.0 {255 - 265}	20.1 {205}	25.0 - 26.0 {255 - 265}	20.1 {205}
15.25 - 16.75	15.25 - 16.75	15.25 - 16.75	15.25 - 16.75	12.25 - 13.75	12.25 - 13.75	15.25 - 16.75	15.25 - 16.75
-	-	83.4 - 112.8 {0.85 - 1.15}	83.4 - 112.8 {0.85 - 1.15}	73.6 - 103 {0.75 - 1.05}	73.6 - 103 {0.75 - 1.05}	88.3 {0.9}	88.3 {0.9}
1,360 - 1,440	1,360 - 1,440	1,085 - 1,145	1,085 - 1,145	1,725 - 1,825	1,725 - 1,825	1,550 - 1,650	1,550 - 1,650
10	8 - 12	automatic tension	-	10	8 - 12	13	12 - 15

615002

13 DISASSEMBLY AND ASSEMBLY

DISASSEMBLY 13-1

● SPECIAL TOOL LIST	13-2	21. Head covers.....	13- 9
1. Starting motor assembly	13-3	22. Nozzle holders	13- 9
2. Engine oil cooler assembly	13-3	23. Rocker arms	13-10
3. Setting to engine overhaul stand	13-3	24. Crossheads	13-10
4. Fan.....	13-4	25. Push rods.....	13-10
5. Engine mounts.....	13-4	26. Rocker arm housings	13-10
6. Air cleaner, bracket assembly	13-4	27. Cylinder head assemblies	13-11
7. Turbocharger, exhaust manifold assembly	13-5	28. Oil pan	13-11
8. Corrosion resistor and piping, wiring	13-5	29. Flywheel	13-12
9. Engine oil filter.....	13-5	30. Rear seal	13-12
10. Lubrication valve	13-6	31. Flywheel housing.....	13-13
11. Fuel filter.....	13-6	32. Front cover	13-13
12. Fuel injection pipes	13-6	33. Fuel injection pump drive gear	13-13
13. Aftercooler assembly.....	13-6	34. Cam follower covers	13-13
14. Fuel injection pump assembly	13-7	35. Cam followers	13-14
15. Alternator assembly	13-7	36. Camshaft.....	13-14
16. Thermostat housing, water pump	13-8	37. Oil pump	13-15
17. Fan pulley, drive assembly	13-8	38. Idler gear	13-15
18. Front support	13-8	39. Oil suction pipe.....	13-15
19. Crankshaft pulley, vibration damper	13-9	40. Piston, connecting rod assembly	13-16
20. Air vent tube, spill pipe	13-9	41. Crankshaft.....	13-17
		42. Piston cooling nozzle.....	13-18
		43. Cylinder liner	13-19

ASSEMBLY 13-21

27. Cylinder head assemblies

- 1) Remove 42 mounting bolts (1), then remove cylinder heads (2).
- 2) Remove each cylinder head gasket.

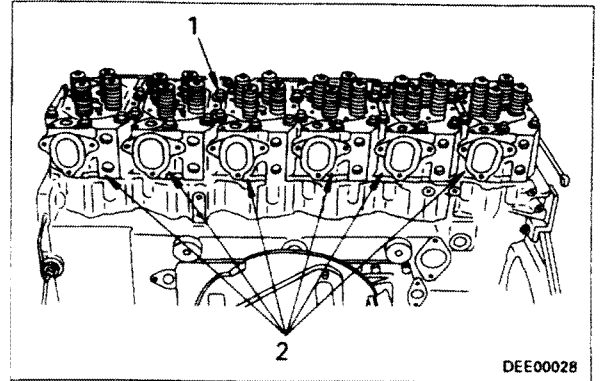

- Disassemble cylinder head assembly as follows.

- i) Using tool B1, compress valve spring (3) and remove valve cotters (4).
- ii) Remove upper seat (5) and valve spring (3).

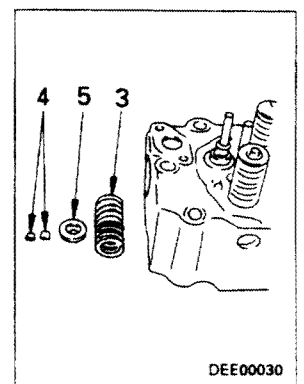
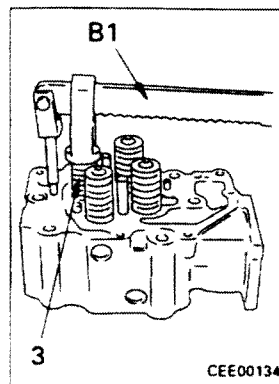

- iii) Remove seal (7), then remove lower seat (8).
- iv) Raise cylinder head and remove valves (6).
 - ★ The seat is installed only on the exhaust side.
 - ★ Mark the valve with a number to show the combination with the head.

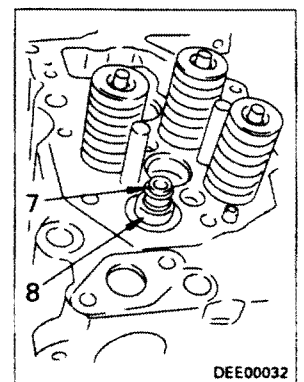
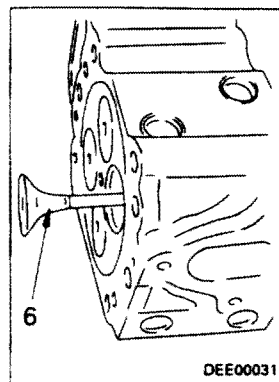

28. Oil pan

Remove oil pan (1).

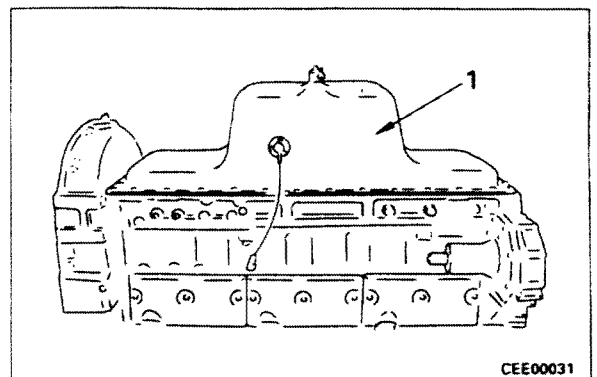

615002

ASSEMBLY

1. Cylinder liner	13-23	24. Rocker arms	13-47
2. Piston cooling nozzle	13-25	25. Adjusting valve clearance	13-48
3. Crankshaft	13-25	26. Nozzle holders	13-48
4. Piston and connecting rod assembly	13-28	27. Head covers	13-49
5. Oil suction pipe	13-33	28. Spill pipe, air vent tube	13-49
6. Idler gear	13-33	29. Pulley, front support	13-49
7. Oil pump	13-33	30. Drive sensor, tubes, bracket	13-50
8. Camshaft	13-34	31. Thermostat housing, water pump	13-50
9. Cam followers	13-34	32. Alternator assembly	13-51
10. Cam follower covers	13-34	33. Adjusting V-belts	13-51
11. Fuel pump drive gear	13-35	34. Aftercooler assembly	13-51
12. Fuel injection pump assembly	13-36	35. Fuel injection pump pipes	13-52
13. Adjusting fuel injection timing	13-37	36. Lubrication valve	13-52
14. Front cover	13-38	37. Engine oil filter	13-53
15. Crankshaft pulley, vibration damper	13-38	38. Corrosion resistor and piping, wiring	13-53
16. Flywheel housing	13-38	39. Turbocharger, exhaust manifold assembly	13-53
17. Rear seal	13-40	40. Air cleaner, bracket assembly	13-54
18. Flywheel	13-42	41. Engine mounts	13-54
19. Oil pan	13-44	42. Fan	13-55
20. Cylinder head assemblies	13-44	43. Moving to engine overhaul stand	13-55
21. Rocker arm housings	13-46	44. Engine oil cooler assembly	13-55
22. Push rods	13-46	45. Starting motor assembly	13-55
23. Crossheads	13-47	● Filling with oil	13-55

- ★ When assembling a new connecting rod, mark the cylinder number with an electric pen (do not use a stamping tool).

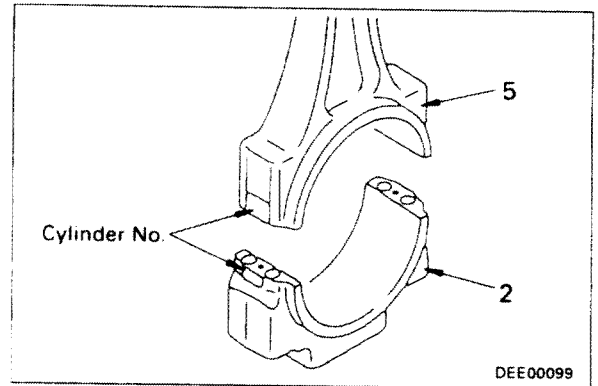

- 13) Before tightening connecting rod bolt, make sure as follows.

- i) Measure the free length a of all bolts and check that bolt length exceeds tolerance limit or not. Do not reuse any bolt which has exceeded the tolerance limit.

Before tightening, measure the free length of bolt and check that bolt length exceeds tolerance limit or not.

- ii) Tolerance limit of bolt free length:

Max. 84.1 mm

- ★ If the bolt length a exceeds tolerance limit, do not reuse.

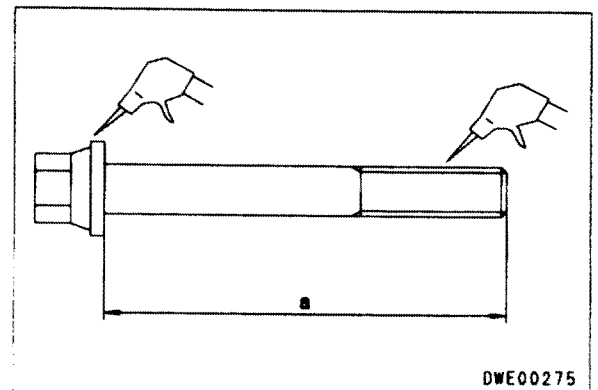

- 14) Coat washer and thread of connecting rod bolt with engine oil (SAE30).

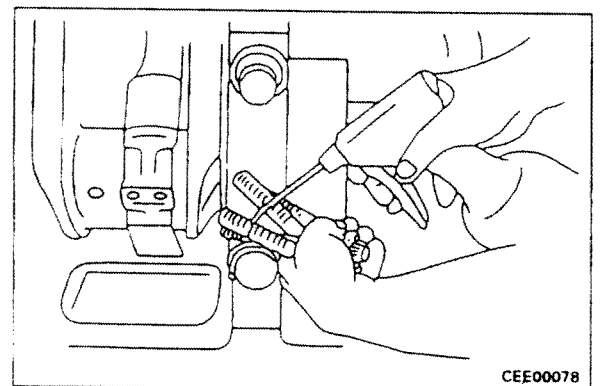

- 15) Tighten connecting rod bolts (1) in turn until connecting rod cap is tightly fitted.

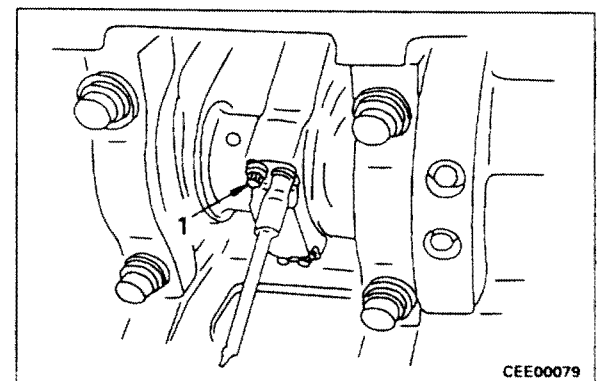

615002

- 1) Put large inside diameter end of plastic inner tube (3) in contact with end of crankshaft (4).
 - ★ Be particularly careful not to mistake the direction when assembling.

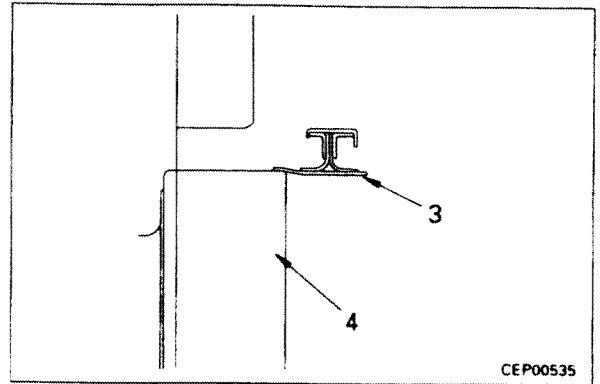

- 2) Hold metal ring of seal (2) with both hands, push evenly, and use sudden pushing force to push in.
- 3) After pushing in seal, remove plastic inner tube (3).
 - ★ Be particularly careful not to damage the seal lip when removing the inner tube.

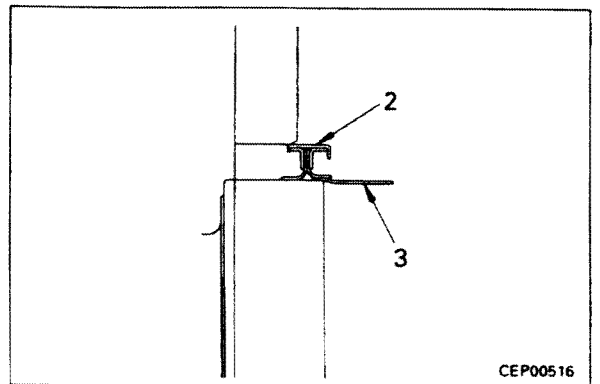

- 4) Tighten bolts (C2-2, C3-1) uniformly until end face of tool C3 contacts end face of crankshaft (4) to press fit seal (2).
 - ★ When press fitting the seal, be extremely careful not to damage the lip at the PTO end when setting the tool.
 - ★ After press fitting the seal, remove the red sealant layer from the outside circumference.

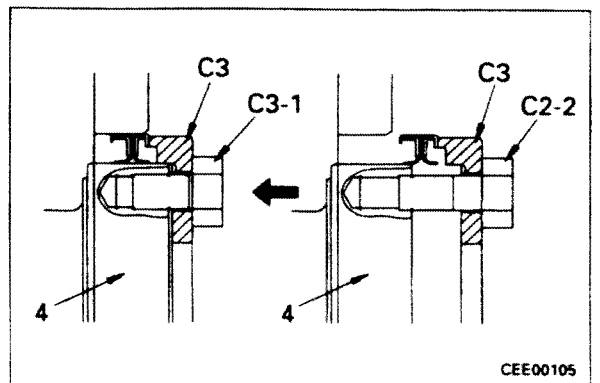

- **Procedure for assembling seal with sleeve**
 - ★ Before assembling the seal, check that there is no damage, burrs, flashes, or rust on the housing, sliding surface of the lip and the corner of the end face of the crankshaft.
 - ★ When assembling the seal, do not coat the shaft, and the space between the sleeve and seal lip with oil or grease. If there is any oil or grease on the shaft, wipe it off completely.
 - ★ Handle the seal and sleeve as an assembly. Never separate them.

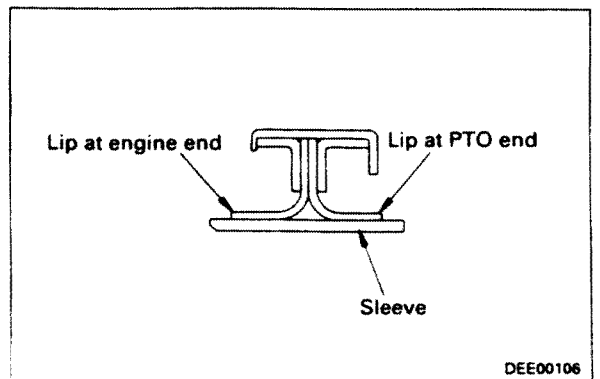

32. Alternator assembly

- 1) Install mounting brackets (9) and (8).
- 2) Install alternator assembly (7) to bracket (9), then install rod (1) with bolt (5).

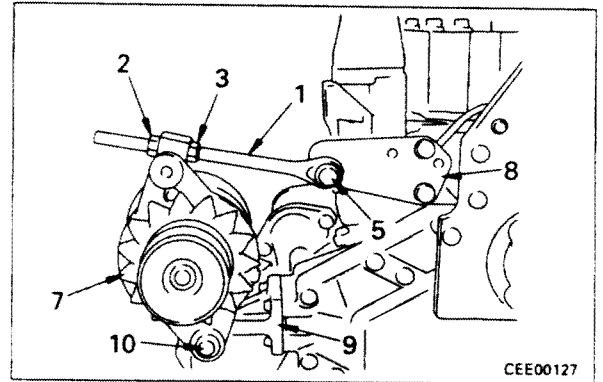
**33. Adjusting V-belts**

- 1) Fit 2 V-belts (4) to pulley groove, loosen nut (2) of tension adjustment rod (1), then tighten nut (3) to adjust V-belt tension.
 - ★ Adjust so that the deflection is 13 mm when the belt is pressed at the mid point with a force of 59 N (6 kg).
- 2) After adjusting tension, tighten bolts (10), (5), (2), and (1).

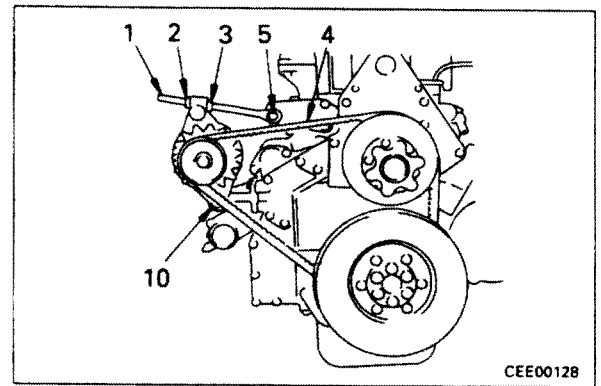
**34. Aftercooler assembly**

- 1) Raise aftercooler assembly (2), assemble mounting bolts (1) to gasket, heater (3), and gasket, then align with cylinder head and install temporarily.
 - ★ Check that the gaskets are assembled securely.
 - ★ Connect the heater wiring securely.
- 2) Tighten 24 mounting bolts (1) of aftercooler (2).

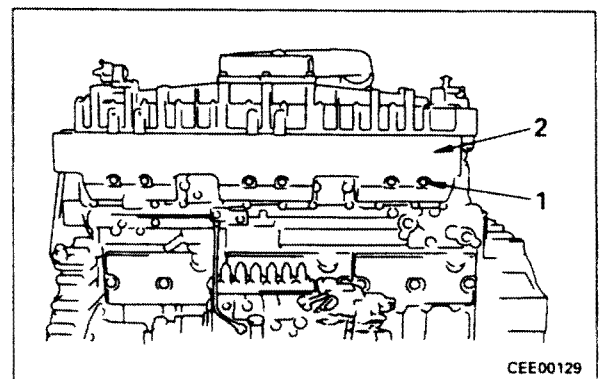
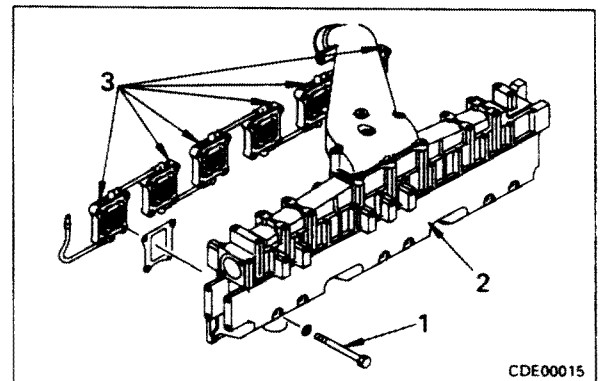

-

-

-

-

CAM FOLLOWER AND PUSH ROD

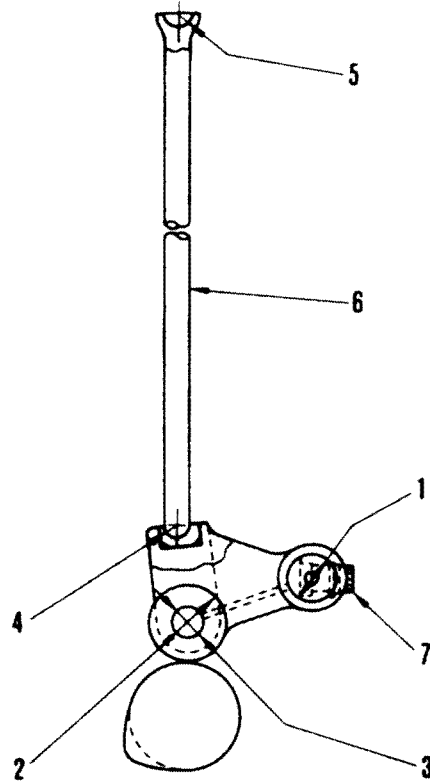

6150F428

615002

Unit : mm

No.	Item	Criteria			Remedy
		Standard	Tolerance	Repair limit	
1	Outside diameter of cam follower shaft	19.8	-0.040 -0.050	19.73	Replace
	Inside diameter of cam follower shaft hole	19.8	+0.020 0		
2	Outside diameter of cam roller	32	-0.250 -0.280	31.71	
3	Inside diameter of cam roller	13	-0.262 -0.287	12.78	
	Outside diameter of cam roller pin	13	-0.364 -0.376	12.62	
4	Radius of push rod ball end	Standard	Tolerance		
		12.7	0 -0.20		
5	Radius of push rod socket end	12.7	0 -0.20		
6	Bend of push rod	Repair limit : 0.50 (Total indicator reading)			
7	Tightening torque of cam follower housing mounting bolt	51 ± 7.3 Nm (5.25 ± 0.75 kgm)			Retighten

WATER PUMP AND THERMOSTAT

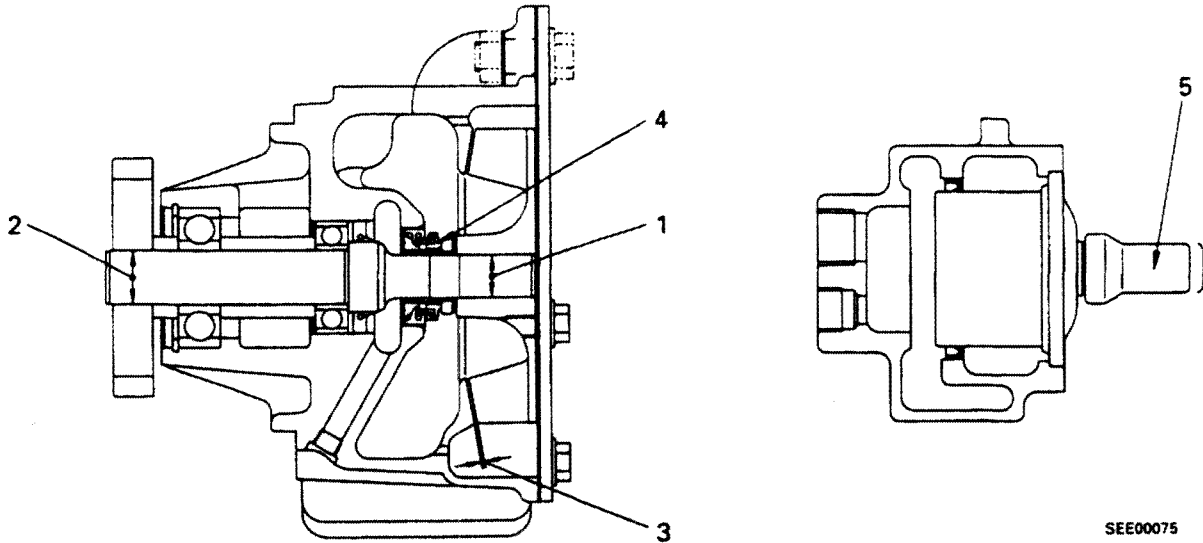

615002

Unit: mm

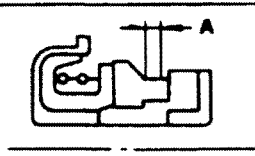
No.	Item	Criteria					Remedy
		Standard size	Tolerance		Standard interference	Interference limit	
	Shaft		Hole				
1	Interference between impeller and shaft	15.9	+0.018 +0.005	-0.020 -0.050	0.025 - 0.068	-	Replace impeller
2	Interference between drive gear and shaft	20.0	+0.015 +0.002	-0.023 +0.053	0.025 - 0.068	-	Replace gear
3	Clearance between impeller and body	Standard: 0.30 - 1.10 (Include end play)					
4	Abrasion of seal ring in water seal				Repair limit A: 1.5		Replace
5	Lift of thermostat valve	Min. 10 (Check after immersion in a hot water bath of 90°C for 4 or 5 minutes.)					Replace
	Opening and closing of valve in thermostat	Valve must be close fully when immersed in a hot water bath (71°C) for 4 or 5 minutes after being immersed in a hot water bath (90°C) to fully open the valve.					

Mounting hole for valve seat insert Unit: mm

	Valve	D ₁	D ₂	H
S.T.D.	Intake	47.5 ^{+0.020} / _{-0.010}	50.30 ± 0.2	11.38 ± 0.1
	Exhaust	46.5 ^{+0.020} / _{-0.010}	49.30 ± 0.2	10.7 ± 0.1
0.25 O.S.	Intake	47.75 ^{+0.020} / _{-0.010}	50.55 ± 0.2	11.38 ± 0.1
	Exhaust	46.75 ^{+0.020} / _{-0.010}	49.55 ± 0.2	10.7 ± 0.1
0.50 O.S.	Intake	48.0 ^{+0.020} / _{-0.010}	50.80 ± 0.2	11.5 ± 0.1
	Exhaust	47.0 ^{+0.020} / _{-0.010}	49.80 ± 0.2	10.82 ± 0.1
0.75 O.S.	Intake	48.25 ^{+0.020} / _{-0.010}	51.05 ± 0.2	11.63 ± 0.1
	Exhaust	47.25 ^{+0.020} / _{-0.010}	50.05 ± 0.2	10.95 ± 0.1
1.00 O.S.	Intake	48.5 ^{+0.020} / _{-0.010}	51.30 ± 0.2	11.76 ± 0.1
	Exhaust	47.5 ^{+0.020} / _{-0.010}	50.30 ± 0.2	11.08 ± 0.1

- ★ Inside surface roughness: 12.5S max.
- ★ Mounting hole bottom roughness: 12.5S max.
- ★ Concentricity of valve guide hole and insert: 0.07 mm (T.I.R) max.

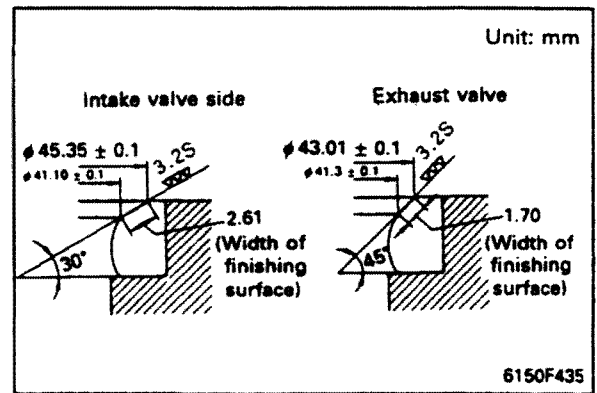
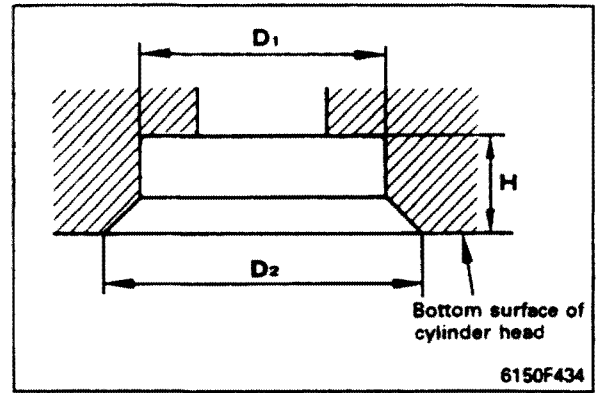

4. Finishing insert seat surface

- 1) Using tools C₁, C₃, and C₄, finish the insert seat surface to the dimensions shown in the diagram.
 - ★ When inserting the pilot into the valve guide, select a pilot that will enter and leave no clearance.

- 2) Fit the seat surface using the compound.

5. Final check

- Coat the seat surface thinly with minimum (red lead), and insert a new valve into the valve guide. Put it lightly in contact with the valve insert surface, and rotate 10°, then check the contact surface with the valve insert. Confirm that the contact is uniform with no breaks.
- Another way is to mark the new valve with pencil marks as shown in the diagram, insert into the valve guide, bring into light contact with the valve insert surface, and rotate 10°. Check that the pencil marks are erased uniformly around the whole circumference.
- ★ If a vacuum tester is available, carry out an airtightness test to check.

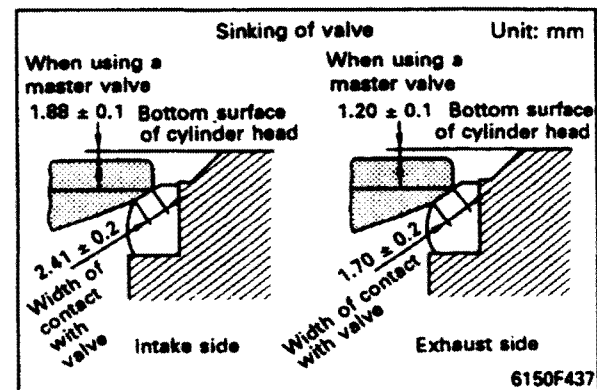
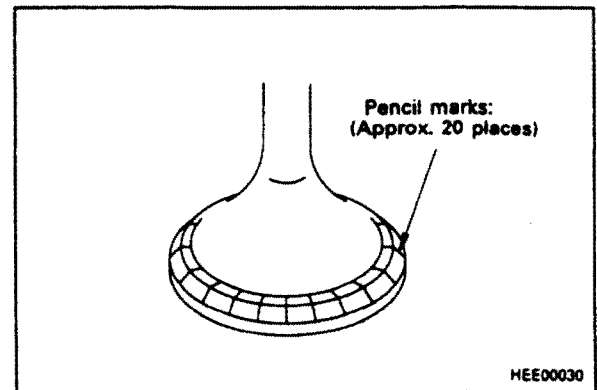

615002

4. Install seal with sleeve (when equipped with sleeve)

- The shape of the spare seal when shipping is as shown in the right.
 - ★ Handle seal (4) and sleeve (5) as an assembly. Do not separate them.

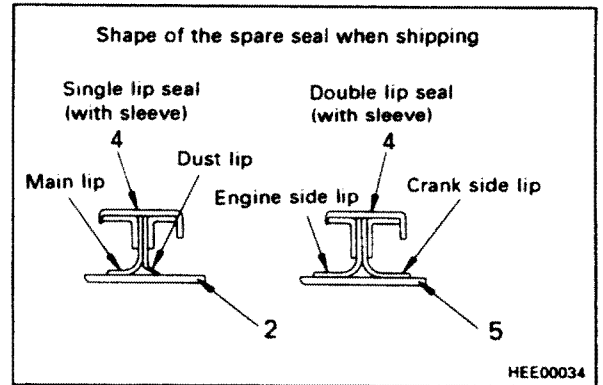

- 1) Coat inside surface (c) of sleeve (5) with gasket sealant, then set on tool C.
 - ★ Before assembling seal (4), remove all scratches, burrs, flashes, and rust from the end face corner and sliding face (d) of lip of crankshaft shaft (3) and fly-wheel housing (1).
 - ★ Do not coat the area between sleeve (5) and seal lip (d) with oil.

 Gasket sealant : LG-7

- 2) Put sleeve (5) in contact with the end face of crankshaft (3), tighten uniformly with bolts (6), and assemble sleeve (5) and seal (4) as one unit.
 - ★ Tightening bolt (6): 01050-31645 (x 3)

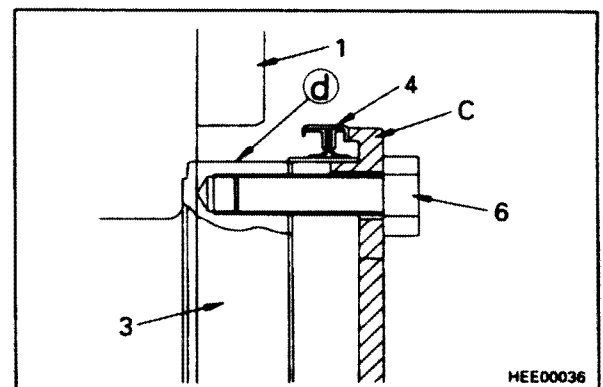
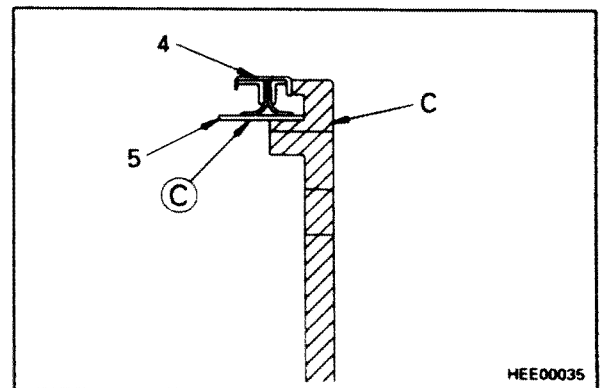

- 3) Press fit sleeve (5) and seal (4) until tool C contacts end face (e) of crankshaft (3).
 - ★ Remove tool C when it contacts end face (e) of crankshaft (3).

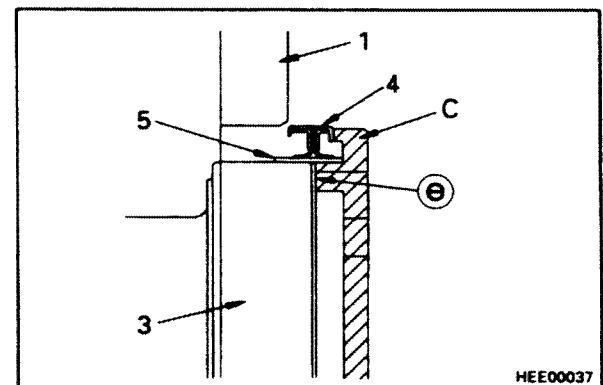

615002

CLICK HERE TO **DOWNLOAD** THE COMPLETE MANUAL

- Thank you very much for reading the preview of the manual.
- You can download the complete manual from: www.heydownloads.com by clicking the link below



- Please note: If there is no response to CLICKING the link, please download this PDF first and then click on it.

CLICK HERE TO **DOWNLOAD** THE COMPLETE MANUAL