

KOBELCO

OPERATOR'S MANUAL
HYDRAULIC EXCAVATOR
SK70SR

CLICK HERE TO **DOWNLOAD** THE COMPLETE MANUAL

- Thank you very much for reading the preview of the manual.
- You can download the complete manual from: www.heydownloads.com by clicking the link below



- Please note: If there is no response to CLICKING the link, please download this PDF first and then click on it.

CLICK HERE TO **DOWNLOAD** THE COMPLETE MANUAL

Section I – SAFETY PRECAUTIONS

B. PASSENGERS

This equipment is not intended or designed for the transportation of persons. Never allow persons to ride on the machine. Serious injury or death can result from allowing passengers on or in the machine.

C. TRAVEL

Make certain of the location of the Travel Motors before operating travel controls. Sound Horn before moving the machine to inform persons that the machine is travelling. Position the attachment as shown in illustration before beginning travel. Move the machine at slow speeds. Do not turn suddenly on rough terrain. Avoid travelling over obstacles. Should it become necessary to travel over an obstacle, keep the attachment low to the ground and travel at extremely slow speed.

D. SWING

Make certain the Swing Area of machine is clear of all persons and obstacles before operating Swing Controls. Sound Horn before swinging machine. If necessary, have a Flagman signal operator during operation to help prevent injury to persons or damage to obstacles and equipment.

E. BOOM, ARM & ATTACHMENTS

Give the work you are doing your undivided attention. Make certain the attachment being used is suited for the job at hand. Make certain of obstacles in the work area and operate the machine within those limits. If necessary have a Flagman signal the operator to prevent injury to persons or damage to the machine or obstacles in the work area.

ALWAYS PLACE ATTACHMENTS ON THE GROUND AND RAISE THE SAFETY LOCK LEVER BEFORE LEAVING THE CAB.

F. OPERATING ON INCLINES OR SLOPES

Operation of this machine on an incline or slope may cause the machine to become unstable or unbalanced. Work Up and Down inclines or slopes never across. Never Swing or Turn Machine around on slopes. Build a level area for the machine to operate. Operate Controls carefully to prevent sudden movements which may cause the machine to slide or tip over. Use a Flagman to direct the operator.

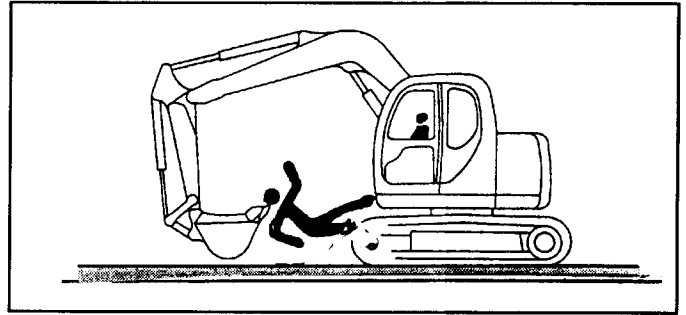

NO PASSENGERS

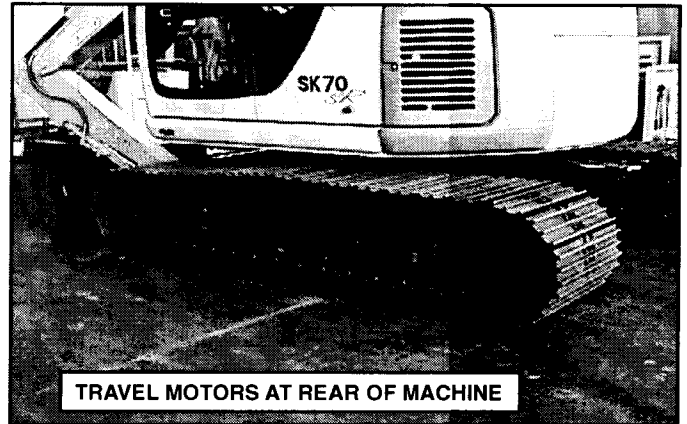

TRAVEL MOTORS AT REAR OF MACHINE

KNOW TRAVEL MOTOR POSITION

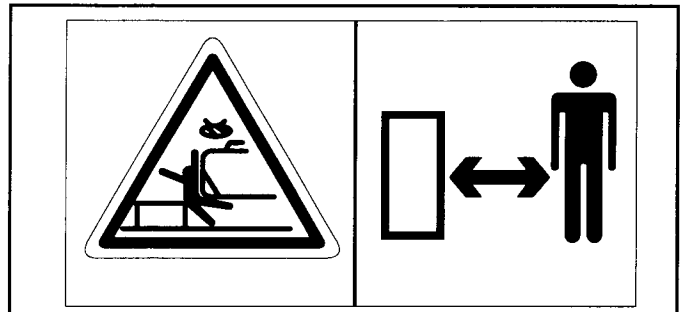

**SWING SAFETY/USE SWING FLASHERS
(Example of EU)**

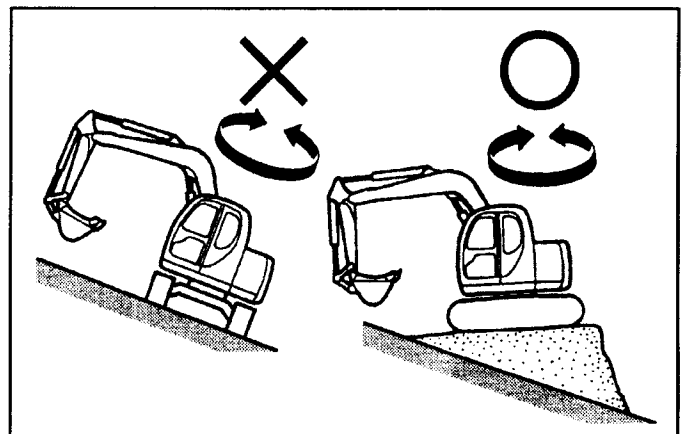

BUILD BANKING FOR SLOPE OPERATION

Section I– SAFETY PRECAUTIONS

27. HANDRAIL - WARNING

Located inside cab R.H.
Part Number - 2432T6019



WARNING

DO NOT INSTALL ANY OBJECT ON THE HANDRAIL. This can cause the welds that fasten the handrail to the operators cab to fatigue and crack due to excessive vibration during machine operation.

Injury to the operator may result if he falls to ground because of the unexpected breakage of the welds.

2432T6019

29. CALIFORNIA PROPOSITION 65 - WARNING

Located inside cab R.H.
Part Number - 2432T6457



WARNING

CALIFORNIA Proposition 65

Diesel engine exhaust and some of its constituents are known to the State of California to cause cancer, birth defects, and other reproductive harm.

2432T6457

28. AUTOMATIC TWO SPEED TRAVEL - WARNING

Located inside cab R.H.
Part Number - YN20T01048P1



WARNING

Automatic two speed travel system changes travel speed automatically and can adversely affect machine control when descending a slope and loading or unloading on a trailer.

Personal injury can occur from sudden change in machine control.

Put travel speed select switch in low speed position when descending a slope and loading or unloading on a trailer.

YN20T010-48P1

Section II– MACHINE FAMILIARIZATION

2.4 COMPONENT & CONTROLS NOMENCLATURE

The following information provides a brief description and function of the components and controls of the KOBELCO SK70SR Hydraulic Excavator.

All personnel associated with this machine should read and understand this information BEFORE beginning any work with or on this equipment.

A. RIGHT HAND OPERATOR CONSOLE

1. Key Switch– FIGURE 2.3

The Key Switch is located on the Right Hand Operator Console and has 5 operating functions.

- a. "HEAT"– This position is used for starting the engine in cold climates. See Section III.
- "OFF"– When Key is turned to this position, the engine stops and electrical power to the machine's electrical systems is stopped after approximately 4 seconds.
- "ACC"– With key in the "ACC" position only the Cigarette Lighter, DC to DC Converter and Horn will have power.
- "ON"– When Key is in the ON position, electrical power is supplied to all the machine's electrical systems.
- "START"– When key is turned to this position electrical power is supplied to the starter solenoid causing the starter to start the engine. After engine starts Key should be released to go back to the "ON" position.

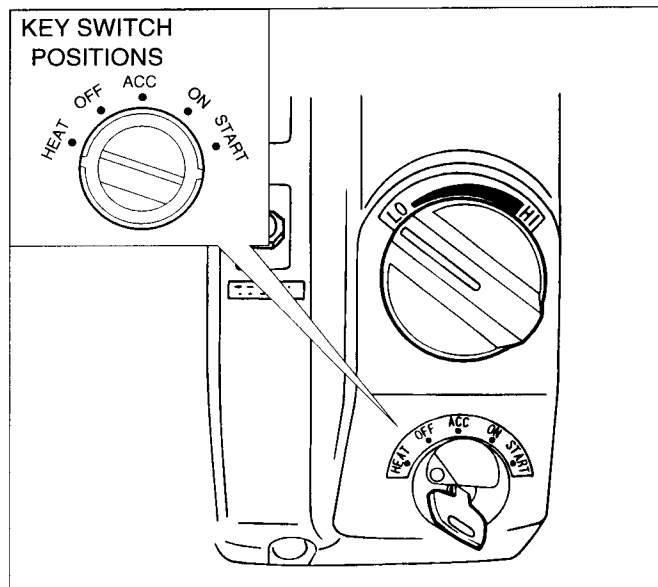

FIGURE 2.3

2. KPSS Mode Switch– FIGURE 2.4

The KPSS Mode Switch is located on the Right Hand Operator Console and has 3 operating functions.

- a. "H" Mode– Use this position for best performance in heavy digging operations.
- b. "S" Mode– Place switch in "S" mode for best performance and control for light duty operations and fuel consumption.
- c. "FC" Mode– Use this position when precision Fine Control is required.

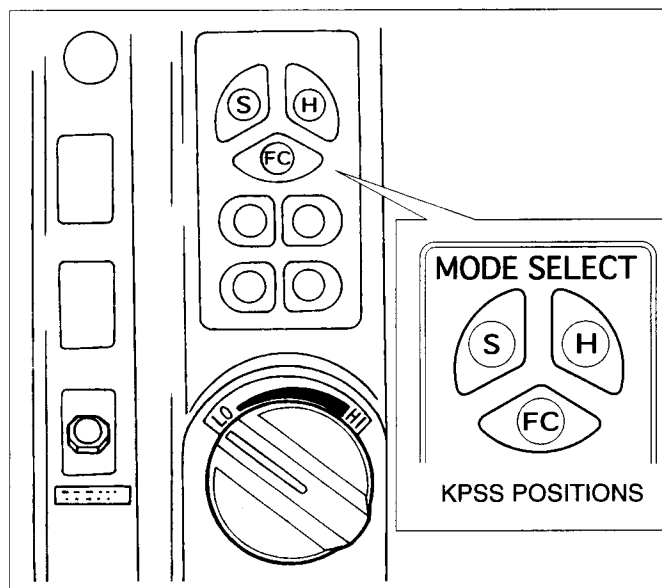

FIGURE 2.4

3. Throttle Potentiometer– FIGURE 2.5

The Throttle Potentiometer is located on the Right Hand Operator Console and controls Engine RPM. When the Throttle Potentiometer is rotated to any position it increases or decreases engine rpm and maintains engine at the programmed RPM for that particular position on the dial.

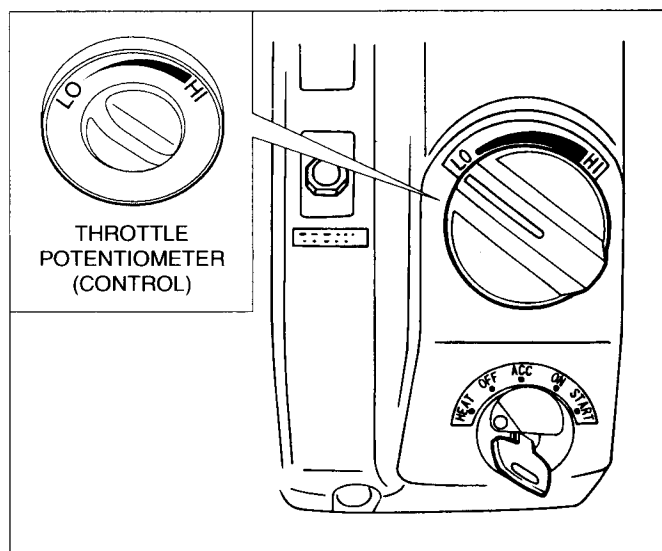

FIGURE 2.5

Section II– MACHINE FAMILIARIZATION

D. OPERATING LEVERS & CONTROLS

1. Safety Lock Lever – FIGURE 2.27

The Safety Lock Lever is located on the front outside of the Left Hand Operator Console and is Red in color. The Safety Lock Lever is used to lock out the hydraulic controls disallowing the use of any hydraulic function. The Safety Lock Lever has 2 operating positions.

- a. "UP"-When placed in the up position the Safety Lock Lever stops all hydraulic controls from functioning and allows the operator to enter and exit the operator seat.
- b. "DOWN"-When placed in the down position, the Safety Lock Lever allows all operating functions of the hydraulic controls to resume and also locks the Left Hand Operating Console in operating position.

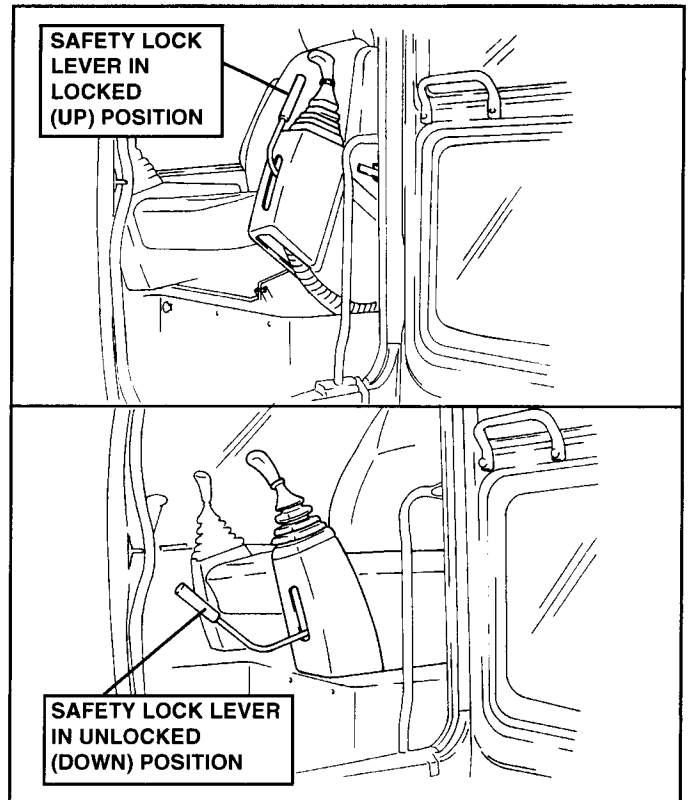



FIGURE 2.27

	WARNING	
<p>ALWAYS PLACE THE SAFETY LOCK LEVER IN THE LOCK OUT (UP) POSITION BEFORE LEAVING THE OPERATOR CAB.</p> <p>NEVER LEAVE THE MACHINE UNATTENDED WITH ENGINE RUNNING OR LEVER IN THE DOWN POSITION.</p>		

2. Engine Emergency Stop Control – FIGURE 2.28

The Engine Emergency Stop Control located at the lower right hand side of operator seat. It is used only in an emergency situation to stop the engine quickly. It has 2 operating positions.

- a. "IN"-Releases the fuel stop lever on the governor to allow normal starting of the engine.
- b. "OUT"-Activates the fuel stop lever on the engine governor to immediately stop the engine.

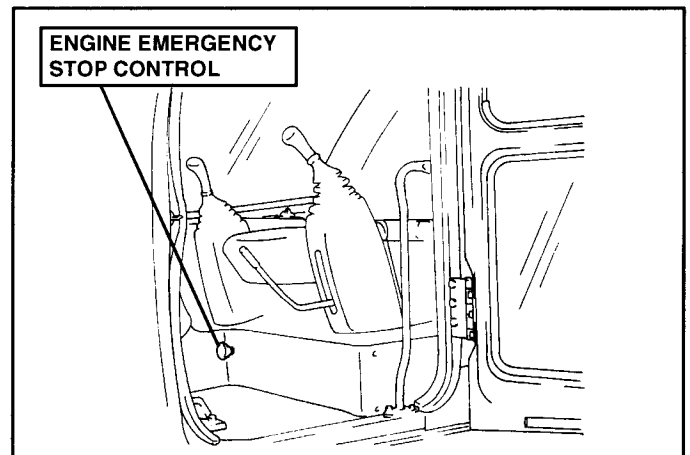

FIGURE 2.28

	CAUTION	
<p>Do Not suddenly stop the engine when operating at high RPM. Doing so may damage turbo or engine.</p>		

Section II– MACHINE FAMILIARIZATION

d. Seat Front to Back Adjustment – FIGURE 2.49

1. Pull up on Seat Adjustment Bail and move seat forward or backward to desired position.

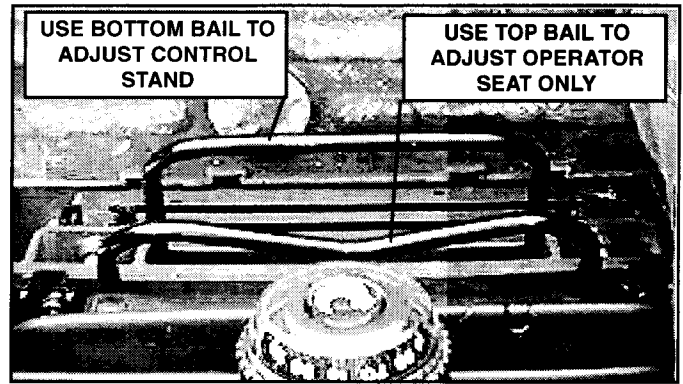

FIGURE 2.49

e. Arm Rest Adjustment – FIGURE 2.50

1. Lower Arm Rest and with finger, turn adjustment wheel until Arm Rest is in desired position.

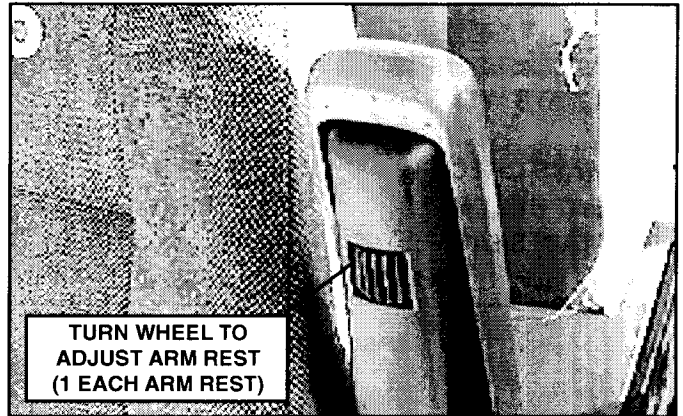

FIGURE 2.50

f. Head Rest Adjustment – FIGURE 2.51

1. Move Head Rest forward or backward to desired reclining angle.
2. Raise or Lower Head Rest to desired height.

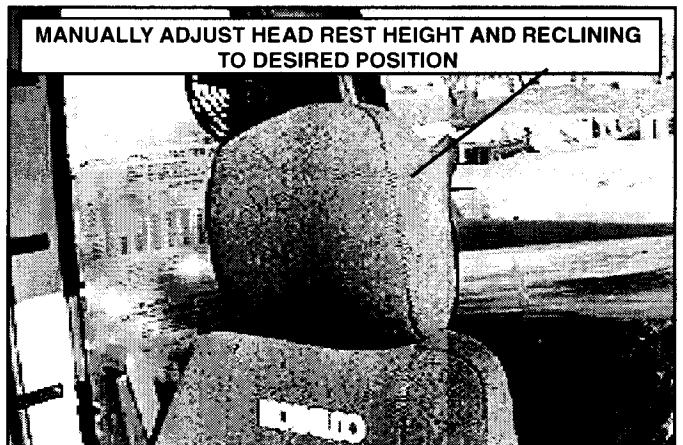

FIGURE 2.51

Section III– BASIC MACHINE OPERATION

3.7 BASIC OPERATION OF HYDRAULIC CONTROLS

The following instructions are aimed at providing an operator with the basic function of each hydraulic control. Use of these instructions, and practice with a machine, will allow a given operator to become more efficient in the operation of this equipment.

Each operator must read, understand and follow these basic instructions along with all safety precautions found in this manual and on the machine before operating this equipment.



WARNING



NORMAL POSITIONING OF THE MACHINE FOR THE SAKE OF DETERMINING FRONT, REAR, FORWARD AND REVERSE ARE WITH THE TRAVEL MOTORS LOCATED AT THE BACK OF THE MACHINE. SEE FIGURE 3.20.

ALWAYS KNOW THE LOCATION OF TRAVEL MOTORS BEFORE OPERATING ANY HYDRAULIC CONTROLS.

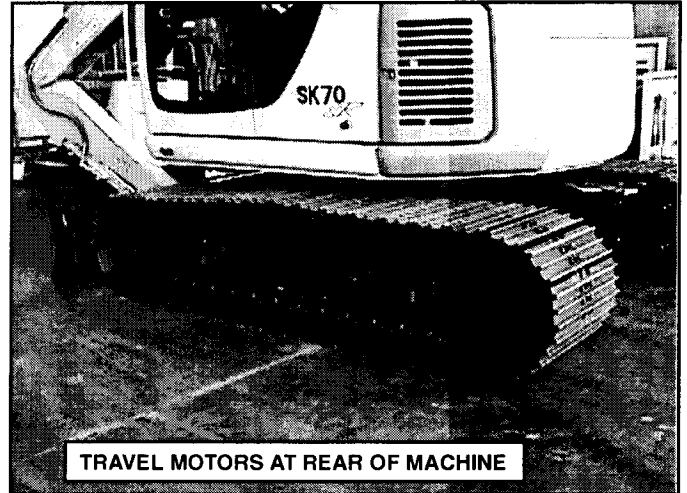

FIGURE 3.20

A. SAFETY LOCK LEVER– FIGURE 3.21

1. Unlocked Position

Before any Hydraulic Operation is possible the Safety Lock Lever must be placed in the "UNLOCKED" (DOWN) position. Placing the Safety Lock Lever in the UNLOCKED (DOWN) position also positions the L.H. Operators Console in its operating position.

2. Locked Position

Before leaving the operator cab, place the Safety Lock Lever in the "LOCKED" position by pulling lever up. With Safety Lock Lever in the "LOCKED" (UP) Position, no hydraulic operation is possible and allows easy access in and out of the operator seat.

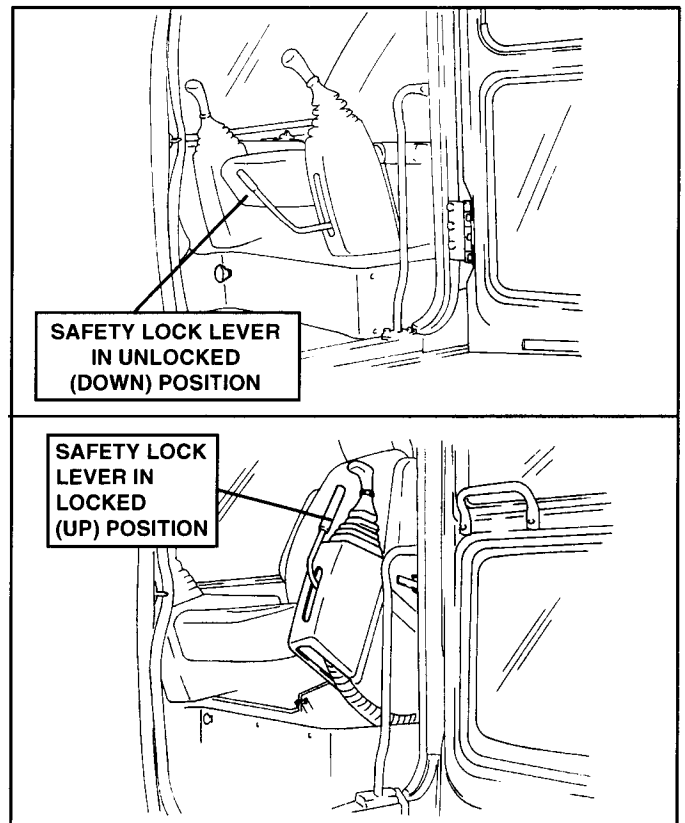

FIGURE 3.21



WARNING



ALWAYS PLACE THE SAFETY LOCK LEVER IN THE "LOCKED" (UP) POSITION BEFORE LEAVING CAB TO PREVENT ANY OPERATION OF HYDRAULIC CONTROLS.

FAILURE TO PLACE SAFETY LOCK LEVER IN THE LOCKED (UP) POSITION COULD RESULT IN SERIOUS INJURY OR DEATH AS WELL AS SERIOUS DAMAGE TO THE MACHINE AND ITS COMPONENTS.

Section III- BASIC MACHINE OPERATION

3.9 FLAGMAN HAND SIGNALS

The following is a compilation of the Hand Signals to be used when a flagman is required for Excavator Operation. All personnel associated with the operation of the excavator should know these signals and their meaning before attempting to operate this machine.

A. RAISE LOAD VERTICALLY

Face Machine Operator, raise right forearm vertical, with index finger pointing up and move hand in a small circular motion. See Figure 3.44.

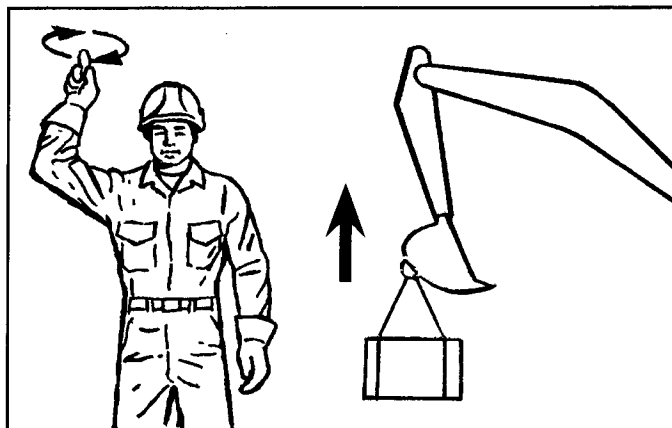

FIGURE 3.44

B. LOWER LOAD VERTICALLY

Face Machine Operator, extend right arm down, point index finger down and move hand in a small circular motion. See Figure 3.45.

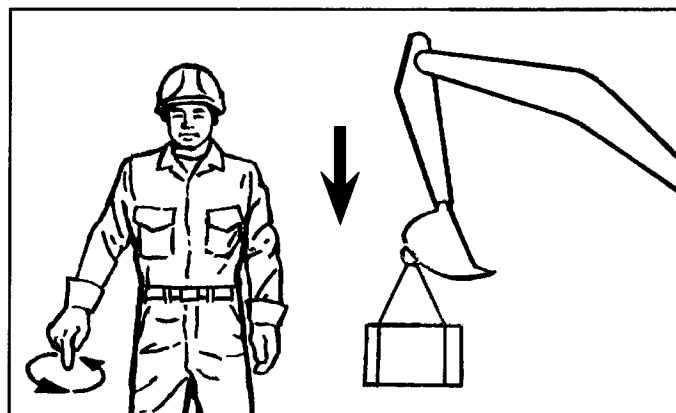

FIGURE 3.45

C. MOVE LOAD IN HORIZONTALLY

Face Machine Operator, extend right arm toward operator with hand facing operator and move hand in direction of movement required. See Figure 3.46.

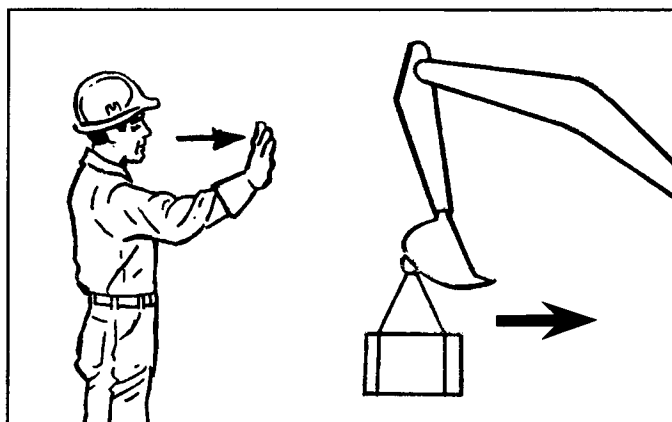

FIGURE 3.46

D. MOVE LOAD OUT HORIZONTALLY

Face Machine Operator, extend right arm toward operator with back of hand facing operator and move hand in direction of movement required. See Figure 3.47.

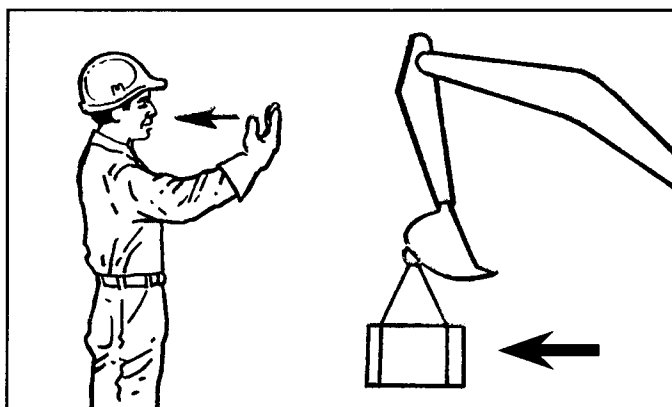

FIGURE 3.47

Section IV– MAINTENANCE

C. Hot Surfaces & Fluids– FIGURE 4.5

Use caution and wear the proper safety equipment when working around hot areas. Never change oils, engine coolant or filters immediately after a machine has been stopped. Allow machine to cool before performing maintenance procedures.

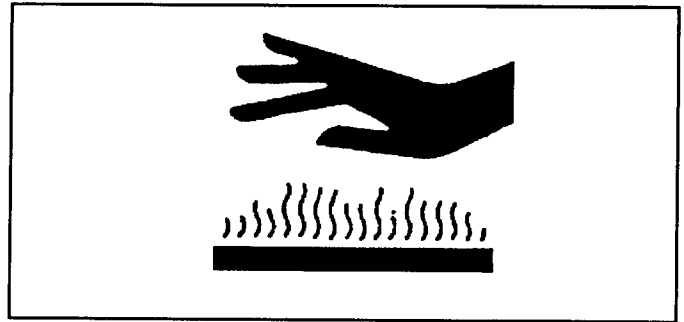

FIGURE 4.5

D. Warm Engine Oil

Engine oil should have a temperature of 20°C ~ 40°C (68°F ~ 104°F) before oil is changed. If necessary run engine until oil is warm.

E. “Tag-Out” Machine– FIGURE 4.6

Before beginning any Inspection or Maintenance procedures, secure a “DO NOT OPERATE” Tag to the operators console to inform the operator that the machine will be inoperable for inspection and maintenance. This tag will help prevent accidental starting of the machine.

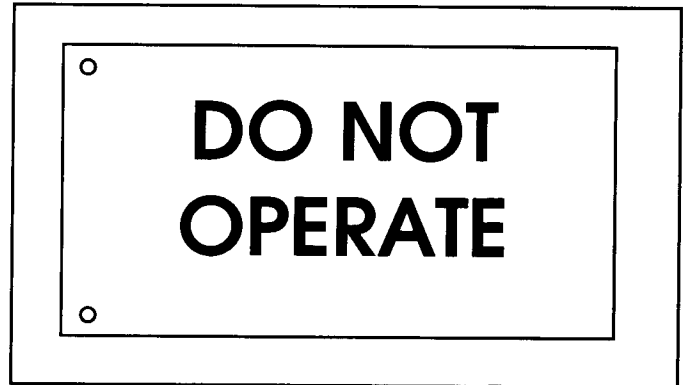

FIGURE 4.6

F. Inspect Waste Oils and Filters– FIGURE 4.7

Before disposal, inspect all waste oils, fluids and filters for debris and foreign material. This can help in determining problem areas.

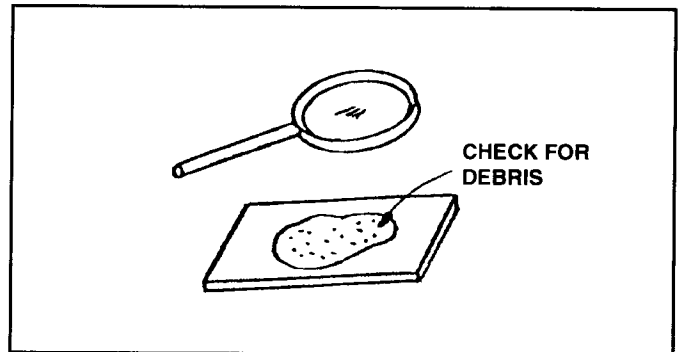



FIGURE 4.7

G. Prevent Contamination– FIGURE 4.8

Always cap or plug lines when hydraulic components are removed to help prevent hydraulic system contamination that can be caused by dirt, dust and debris entering a line or port.

	CAUTION	
<p>Never allow a hydraulic line or component to become contaminated. This could cause severe system damage. Contact an authorized KOBELCO dealer to obtain the proper caps and plugs to be used on this machine.</p>		

H. Seals & “O”-Rings

Always replace seals and “O”-Rings with new parts. Never reuse a seal or “O”-Ring during re-assembly of components. Before installing a new seal or “O”-Ring, coat with a thin layer of oil to help sealing ability.

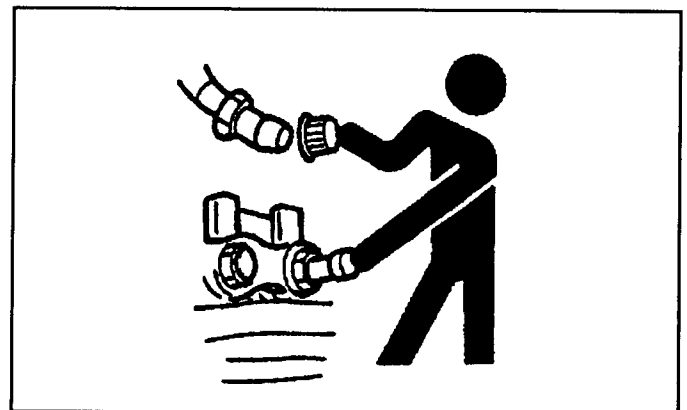

FIGURE 4.8

CLICK HERE TO **DOWNLOAD** THE COMPLETE MANUAL

- Thank you very much for reading the preview of the manual.
- You can download the complete manual from: www.heydownloads.com by clicking the link below



- Please note: If there is no response to CLICKING the link, please download this PDF first and then click on it.

CLICK HERE TO **DOWNLOAD** THE COMPLETE MANUAL

Section IV– MAINTENANCE

G. ENGINE ELECTRICAL

1. Visually and manually inspect all engine electrical wiring, connectors and components for signs of damage and malfunction. See Figure 4.27.
2. Repair or replace all damaged or malfunctioning wiring, connectors and components before resuming operation of the machine.

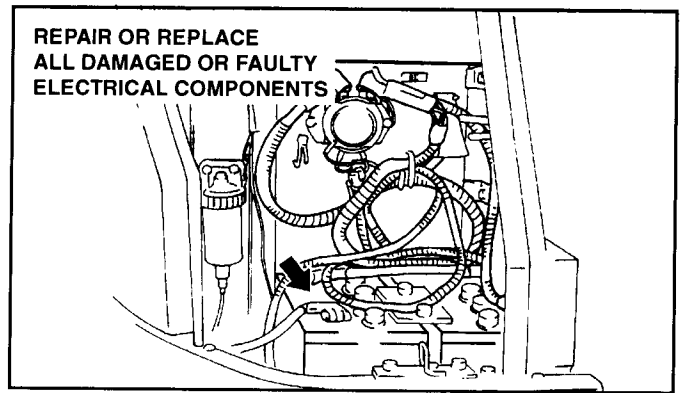

FIGURE 4.27

	WARNING	
OPERATING THE MACHINE WITH DAMAGED OR MALFUNCTIONING ELECTRICAL COMPONENTS CAN CAUSE SERIOUS DAMAGE TO THE MACHINE AND SERIOUS INJURY TO PERSONNEL. REPAIR OR REPLACE FAULTY COMPONENTS IMMEDIATELY.		

H. HYDRAULIC OIL LEVEL

1. Place the machine in the Oil Check Position on a firm surface as shown in Figure 4.28.

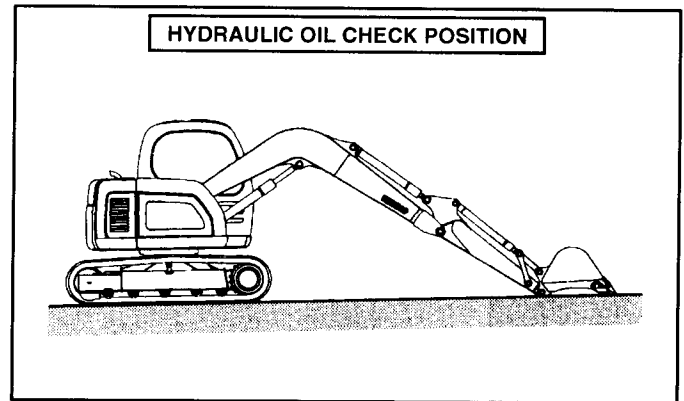

FIGURE 4.28

2. Open Battery Access Cover and view the hydraulic oil level in the sight glass on side of hydraulic oil tank. See Figure 4.29.

	WARNING	
FOR SAFE OPERATION ON INCLINES, THE HYDRAULIC OIL LEVEL MUST BE MAINTAINED BETWEEN “PROPER LEVEL” AND “UPPER LIMIT” MARK.		

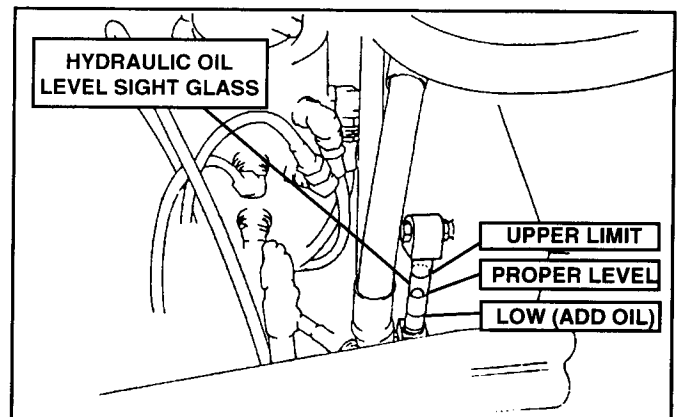

FIGURE 4.29

3. Use the following instructions to add hydraulic oil:
 - a. Release hydraulic tank pressure. See Figure 4.30.

	CAUTION	
Gasses from Hydraulic Tank may be Hot. Wear safety equipment.		

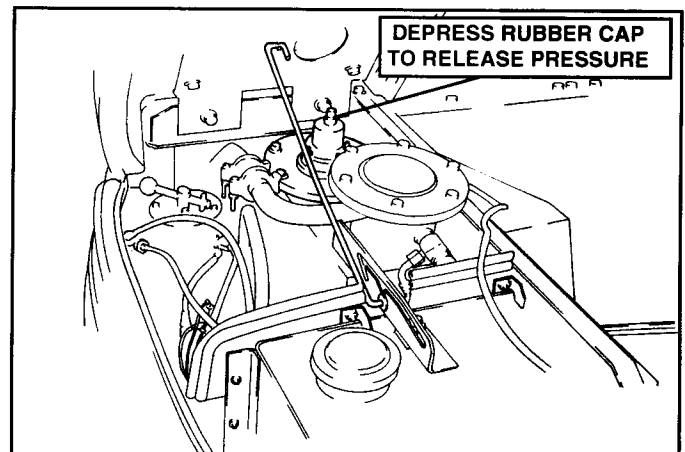

FIGURE 4.30

Section IV– MAINTENANCE

B. ENGINE OIL

Change the engine oil on a new machine after the first 50 hours of operation. Then change the engine oil at every 500 hours of operation.

NOTE

One new oil filter is shipped with the machine in the support kit. This is to be used at the 50 hour oil & filter change.

1. Move the machine to a firm, level surface and run engine for 5 minutes to warm the oil.



WARNING



DO NOT CHANGE OIL ON A MACHINE THAT HAS JUST STOPPED WORKING. THE OIL WILL BE EXTREMELY HOT. ALLOW THE ENGINE TO COOL UNTIL OIL IS JUST WARM BEFORE CHANGING.

2. Remove the four retaining bolts from the oil pan access cover on the bottom, rear center of machine. See Figure 4.60.
3. Raise engine bonnet and remove oil filler cap. See Figure 4.61.
4. Remove Cap from Engine Oil Drain by hand. See Figure 4.62. Place a 10 liter (2.6 Gal) capacity container under oil pan.
5. Install Drain Hose onto oil drain with other end of hose into container. See Figure 4.62. After all oil has drained, remove Drain Hose and replace Oil Drain Cap.
6. Refer to page 4-7 for the proper oil to use and fill engine oil to proper level.
 - Total oil volume to be replaced
SK70SR : 8 liters (2.1 Gal)
7. Install oil filler cap. Clean up all spilled oil.
8. Start engine, run for 5 minutes. While running, check for oil leaks.
9. Should any oil leaks be found, repair immediately and refill with proper oil.
10. Check Oil Level and close cover.

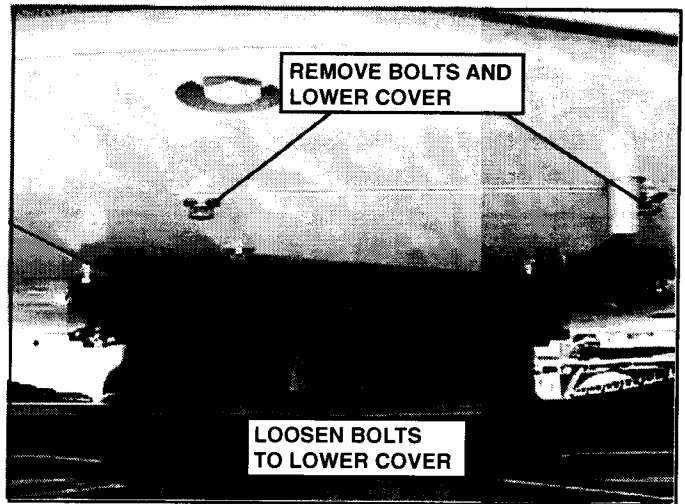

FIGURE 4.60

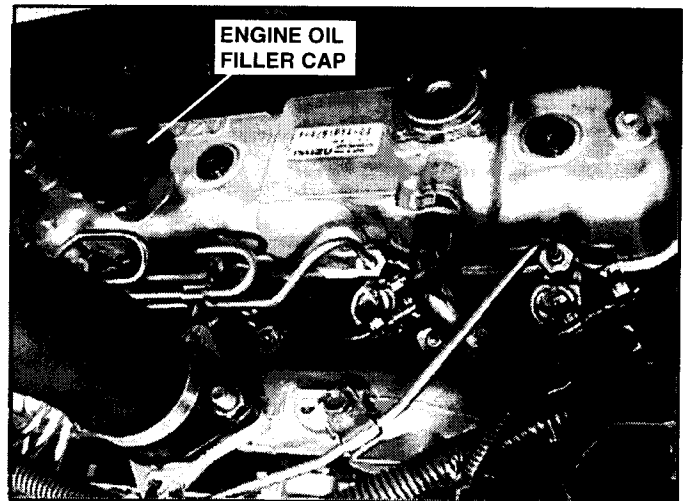

FIGURE 4.61

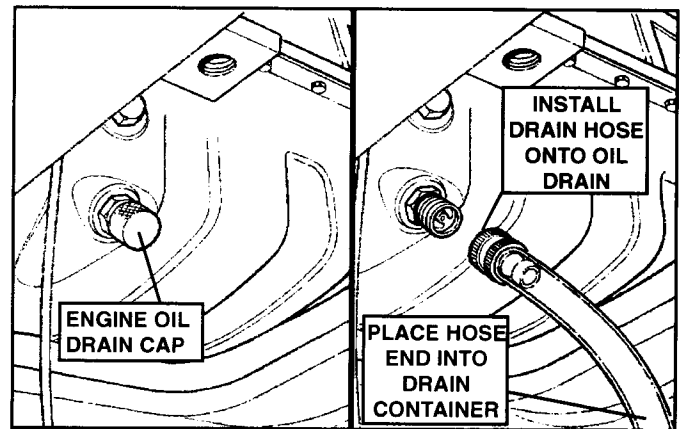

FIGURE 4.62

Section IV– MAINTENANCE

B. Inspection of recirculate and fresh air filters on air conditioner

Cleaning recirculate and fresh air filters.

Recirculate air filter.....Every 500 hours
 Fresh air filter.....Every 250 hours

1. Cleaning fresh air filter
 - a. Loosen 3 bolts under operator's seat, and remove cover.
 - b. Remove cover, and take fresh air filter out.
 - c. Blow compressed air to clean fresh air filter.

NOTE

Water washing is not allowed to clean air filter because it is paper filter.

- d. Cleaning about 10 times is allowed, or replace it with new one every two (2) years.

2. Cleaning recirculate air filter
 - a. Raise recirculate air filter slightly, and pull it out.
 - b. Clean it with water or compressed air blow.

NOTE

Washing with organic solvent (gasoline, trichlene, thinner, etc.) is strictly prohibited.

- c. When frequently clogged, or damage is serious, replace it with new one.
- d. After drying, set outside and recirculate air filters and install cover.

C. Inspecting counterweight attaching bolts for loosening - Figure 4.85A

Check bolts and nuts for loosening. Correct torque is $57 \pm 6 \text{ kgf} \cdot \text{m} (412 \pm 43)$

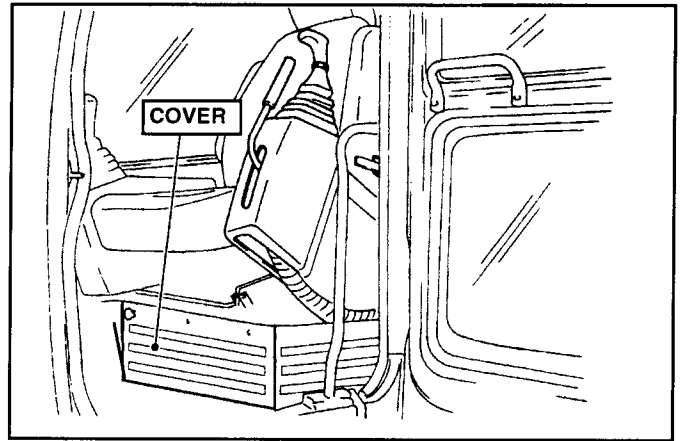

FIGURE 4.84

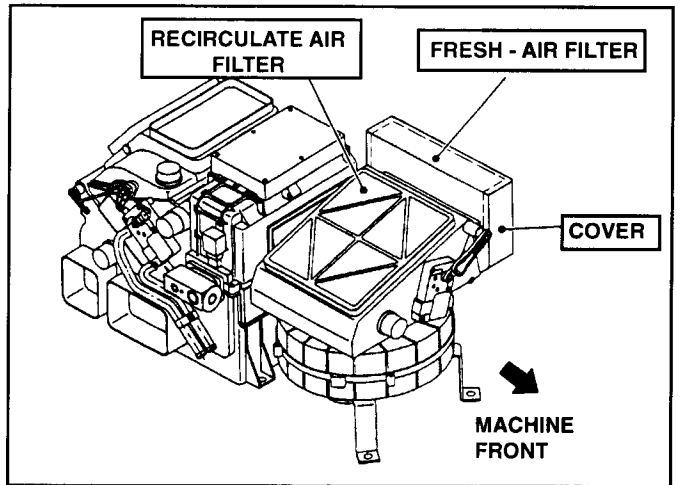

FIGURE 4.85

	CAUTION	
Striking counterweight against obstruction may cause loosening of bolts. Check bolts for loosening after 50 hours the first time, and every 250 hours after that.		

Unit : $\text{Kgf} \cdot \text{m} (\text{ft} \cdot \text{lbs})$

MODEL	TORQUE SPECIFICATION Apply Locktite#242
SK70SR	$57 \pm 6 (412 \pm 43)$

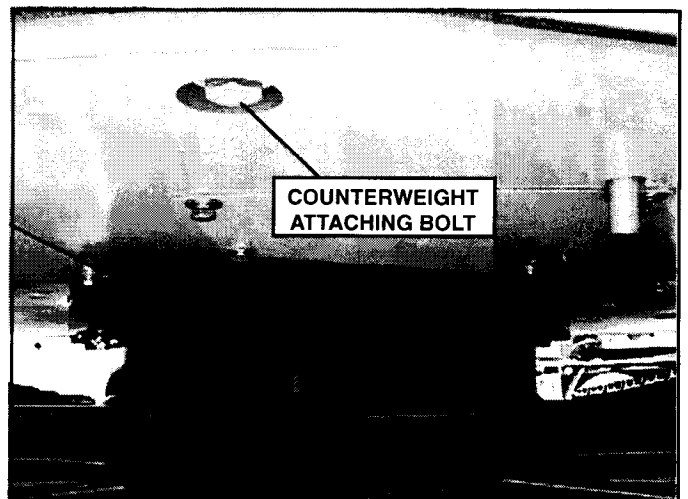

FIGURE 4.85A

Section IV– MAINTENANCE

17. Install Strainer Assembly onto Suction Tube.
18. Install new "O"-Ring, part number ZD11G15500, in cover plate mounting surface groove and install Suction Strainer Cover Plate onto Hydraulic Tank. Make certain Plate Boss is inside Suction Strainer Holder. See Figure 4.110.
19. Torque retaining bolts to proper value. Refer to Specifications Section.
20. Fill Hydraulic Tank to proper level with fresh, clean Hydraulic Oil through Hydraulic Return Filter. See Figure 4.111.

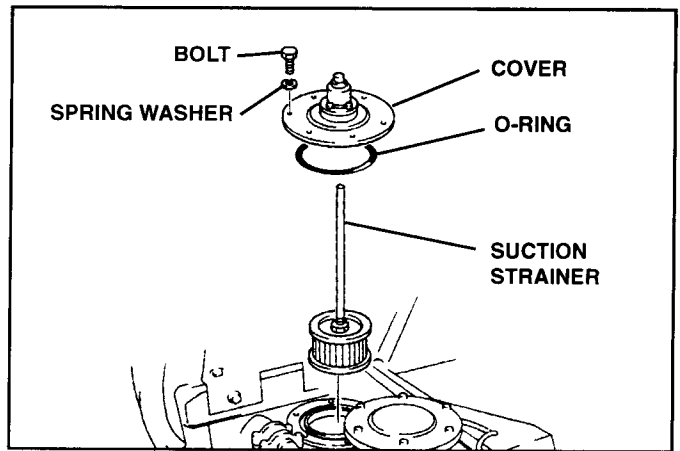

FIGURE 4.110

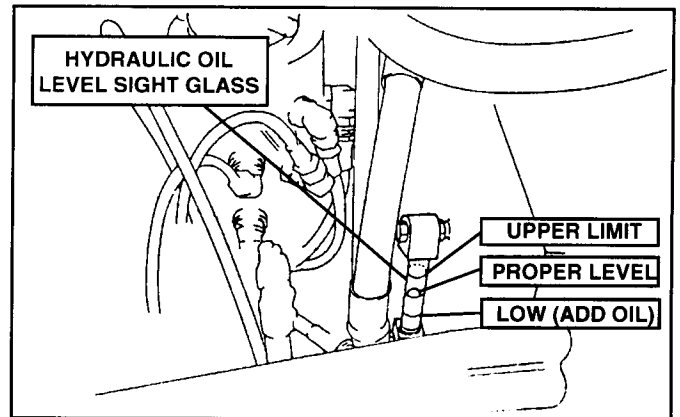

FIGURE 4.111

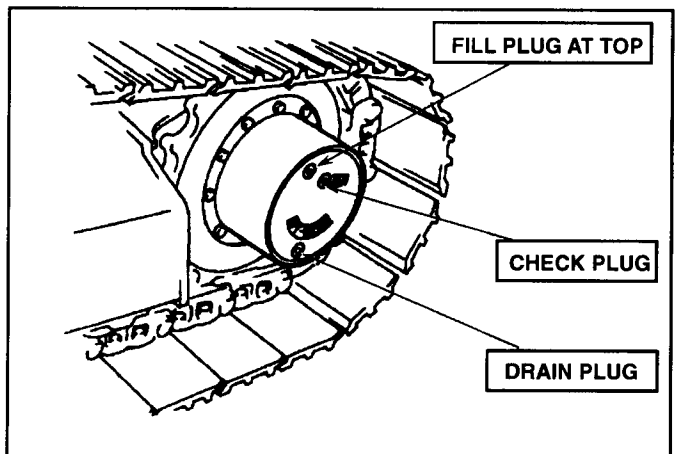

FIGURE 4.112

CAUTION

Use same viscosity oil in Hydraulic Tank as was drained. Refer to Page 4-7 for oil Specifications.

NOTE

This machine was shipped from the factory with ISOVG46 viscosity Hydraulic Oil in hydraulic system.

C. CHANGE OIL IN TRAVEL MOTOR REDUCTION UNITS – 2000 hours

Change the Travel reduction units oil on a new machine after the first 500 hours of engine operation then change every 2000 hours.

WARNING

NEVER CHANGE OILS OR FILTERS ON A MACHINE THAT HAS JUST FINISHED WORKING. ALLOW MACHINE TO COOL FIRST UNTIL OILS AND FLUIDS ARE WARM NOT HOT.

1. Move machine to a firm, level surface. Operate travel until "FILL" Plugs on travel motors are at top. See Figure 4.112.
2. Stop engine and remove the Travel Motor Reduction Unit Oil Level Plug. See Figure 4.112. If oil just seeps from Level port, oil level is correct.
3. To add oil, remove the oil fill plug and add until oil just begins to flow from level plug.
4. To drain oil, remove Fill Plug and Drain Plug. Allow oil to drain into a 2 liter (0.5 Gal) capacity container. Replace drain plug using teflon tape, remove Lever Plug and fill through Fill port using A.P.I Classification for "Service CD"-SAE 30 Engine oil.

NOTE

Capacity of each Travel Motor Reduction Unit is 1.7 liters (0.45 Gallons).

5. Use teflon tape on FILL/LEVEL plugs and replace them.

Section IV– MAINTENANCE

D. MACHINE STORAGE

Perform the following procedure to prepare the machine for long term storage.

1. Perform all Inspection and Maintenance procedures as previously described in this section.
2. Thoroughly clean the machine, inspect for damaged or worn parts and components and replace or repair all damaged or worn parts.

3. Completely fill fuel tank with fresh, clean fuel to aid in preventing condensation of moisture inside the fuel tank.
4. Move machine to an indoor location for storage.
5. Operate bucket and arm completely “IN” extending cylinders. Then lower boom until attachment is resting on the floor. See Figure 4.138.
6. Coat cylinder rods with a heavy coat of grease to prevent corrosion during storage.
7. Remove Batteries and store in a well ventilated, warm area.

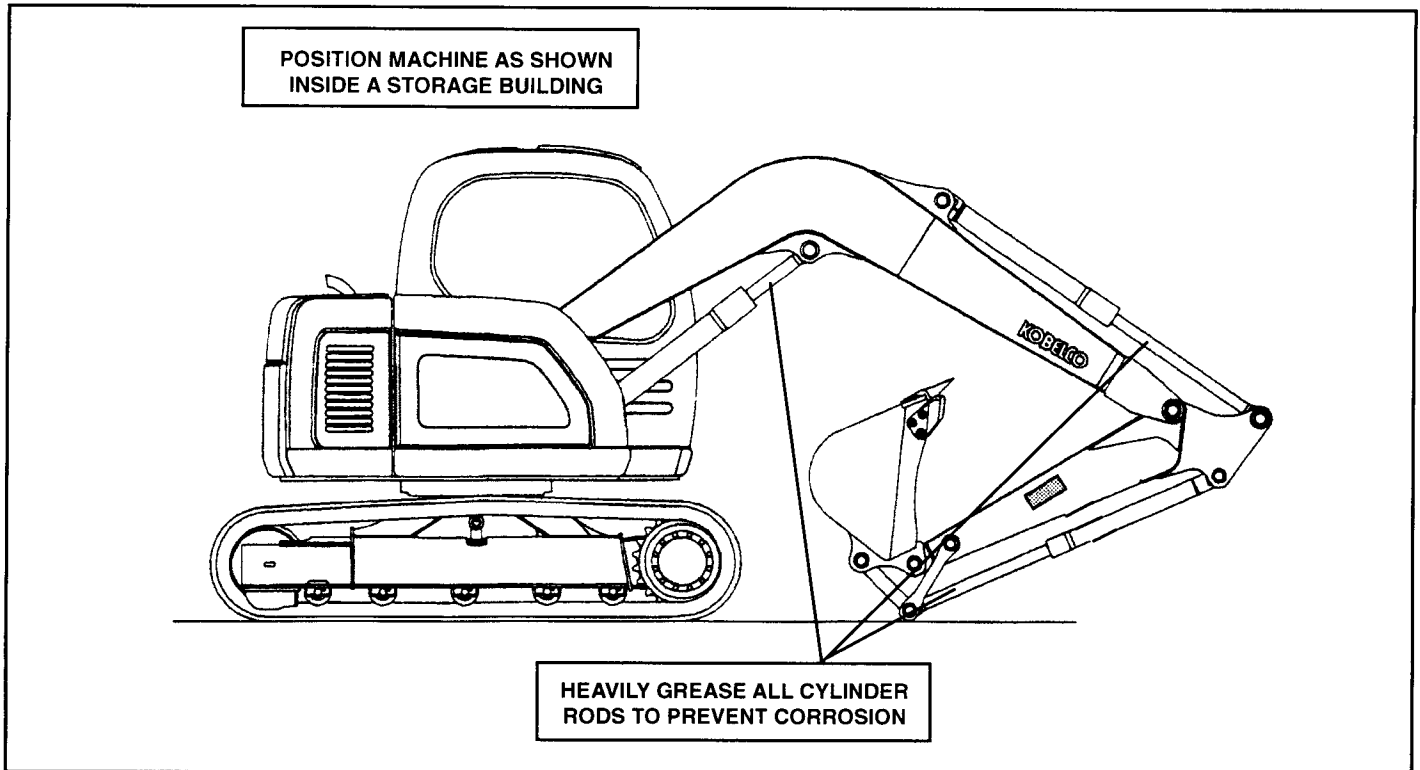
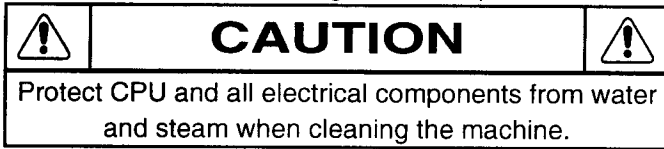

FIGURE 4.138

E. CARE DURING STORAGE

1. Every 30 days during storage, it will be necessary to start and run the machine to circulate the fluids through the systems. Before starting clean cylinder rods and after running re-grease cylinder rods.

NOTE

Run and operate machine for approximately 1 hour to allow all fluids to circulate well and reach normal operating temperatures.

F. REMOVING MACHINE FROM STORAGE



1. Perform all Inspection and Maintenance procedures as described in this section before bringing machine out of storage for normal operation.
2. Remove drain plugs from Travel Motor and Swing Gear Reduction Units to drain off any moisture which may have accumulated during storage.
3. Carefully and closely inspect all Hydraulic Hoses after long periods of storage for signs of deterioration. Replace all hoses showing these signs.

Section V- SPECIFICATIONS

G. PERFORMANCE SPECIFICATIONS

The following Performance Specifications are based on the Standard Machine with Standard Attachment.

1. Travel Speed, Swing Speed & Gradeability

DESCRIPTION	SPECIFICATION
TRAVEL SPEED	5.3 km per hr (3.3 mph) in  mode. 3.4 km per hr (2.1 mph) in  mode.
SWING SPEED	12.5 RPM IN H-Mode / "HI" Idle.
GRADEABILITY	70% (35°)

2. Engine

a. Major Engine Specifications.

Engine Maker	ISUZU
Model	A-4JB1
Type	4-Cycle, Water Cooled, Direct Injection
Number of Cylinders- Bore X Stroke	4-93mm X 102mm (3.66" X 4.01")
Displacement	2,771 liter (169 cu in.)
Compression Ratio	18.2:1
Output Rating (ISO 9249)	40.4 kw / 2,100 rpm (55 PS / 2,100 rpm)
Maximum Torque (ISO 9249)	19.2 kgf•m/ 1,600 rpm (139 lb•ft / 1,600 rpm)
Maximum RPM at No Load- High Idle	2,295 -2,345 rpm
Maximum RPM at No Load- Low Idle	980 - 1020 rpm
Ignition Order	1-3-4-2 Clockwise Rotation
Injection Timing	17±1° Before Top Dead Point
Intake Valve Clearance Cold	0.4 mm (.016")
Exhaust Valve Clearance Cold	0.4 mm (.016")
Electrical System	D.C. 24 V
Starting Motor	24 V-3.2 KW
Alternator	24 V-30 A
Batteries	2- 12 V- (136 Ah)
Engine Dry Weight*	240 kg (529 lbs)
Thermostat	Begin to open at 82°C (180°F). Full open at 95°C (203°F).
Cooling Fan Drive Method	Ø450 (Ø17.7") Suction Type Belt Drive Pulley Ratio: 1.12
Air Cleaner	Dry Type with Safety Elements

*Less flywheel and electrics.

NOTE

For provision affecting the qualified engine complying with EPA requirements for export to North America, refer to pages 9-9 and 9-10.

3. Hydraulic Components

COMPONENT	TYPE
HYDRAULIC PUMPS	Tandem, Variable Displacement, Axial Piston with Pilot Gear Pump.
SWING MOTOR	Axial Piston
TRAVEL MOTOR	Axial Piston
CONTROL VALVES	6 Spool Multiple Control
CYLINDERS (ALL)	Double Acting
RETURN FILTER	Safety Valve containing Filter Type
OIL COOLER	Air Cooled

H. MACHINE & COMPONENT WEIGHTS

The following Weight Specifications are based on the Standard Machine with Standard Attachment.

1. Component Weights

Unit : kg (lbs.)

COMPONENT	SK70SR
COMPLETE MACHINE (STANDARD)	7,180 (15,830)
UPPER FRAME ASSEMBLY	3,250 (7,160)
COUNTERWEIGHT	820 (1,810)
CAB	210 (460)
BOOM CYLINDER*	92 (200)
ENGINE*	240 (530)
RADIATOR*	44 (97)
PUMP ASSEMBLY	44 (97)
CONTROL VALVE	42 (93)
FUEL TANK*	53 (120)
HYDRAULIC TANK*	64 (140)
SWING MOTOR & REDUCTION UNIT	67 (150)
LOWER FRAME ASSEMBLY	2,820 (6,220)
SLEWING RING	115 (250)
TRAVEL MOTOR & REDUCTION UNIT	90 (200) X2
IDLER ASSEMBLY	44 (97) X2
LOWER ROLLER ASSEMBLY	15 (33) X10
UPPER ROLLER ASSEMBLY	4 (9) X2
TRACK TENSION ASSEMBLY	28 (60) X2
SPROCKET	27 (59) X2
SWIVEL JOINT	21 (46)
DOZER BLADE	280 (620)
DOZER BLADE CYLINDERS *	55 (120)
TRACK LINK W/ 600mm (23.6") SHOES	530 (1,170)
TRACK LINK	155 (340) X2
ATTACHMENT (STANDARD)	1,110 (2,450)
BUCKET ASSEMBLY [0.22m ³ (0.29 cu yd)]	190 (420)
ARM ASSEMBLY [2.07m (6'-9")]	290 (640)
ARM [2.07m (6'-9")]	180 (400)
BUCKET CYLINDER*	44 (97)
IDLER LINK	6 (13) X2
BUCKET LINK	8 (17) X2
PIN (2 PCS for mtg bucket cyl & bucket)	17 (37)
BOOM ASSEMBLY	630 (1,390)
BOOM	390 (860)
ARM CYLINDER*	72 (160)
PIN (Mounting the Arm & Arm Cyl)	16 (35)
FLUIDS	130 (290)
HYD OIL, ENG OIL	54 (119)
FUEL	71 (156)
WATER	5 (11)

* DRY WEIGHT



WARNING



USE ONLY LIFTING DEVICES AND EQUIPMENT WITH RATED CAPACITIES SUFFICIENT TO LIFT THE SPECIFIC COMPONENT(S) BEING REMOVED OR INSTALLED.

Section V– SPECIFICATIONS

C. BUCKET & ARM COMBINATIONS

BUCKET m ³ (cu yd)		ARM		
SAE (JIS) (HEAPED)	JIS, SAE (STRUCK)	1.65m (5'-5")	2.07m (6'-9")	1.65m (5'-5") + EXTENSION
0.11 (0.14)	0.19 (0.12)	○	○	○
0.14 (0.18)	0.12 (0.16)	○	○	○
0.18 (0.24)	0.14 (0.18)	○	○	○
0.22 (0.29)	0.18 (0.24)	○	∅	∅
0.28 (0.37)	0.22 (0.29)	∅	▲	▲
0.35 (0.46)	0.26 (0.34)	▲	X	X

- – Normal Working
- ∅ – Standard
- ▲ – Light Duty Only
- X – Do Not Use This Combination

5.3 TORQUE SPECIFICATIONS

The following Torque Specifications are provided for use when actual torque value of a fastener is not known.

A. CAPSCREWS & NUTS

1. Metric Coarse Thread Standard Tightening Torque Values. Make certain to tighten all Capscrews & Nuts to proper torque values.

Classification	4	T		10		T	
		NO LUBRICATION	OIL LUBRICATION	NO LUBRICATION	OIL LUBRICATION	NO LUBRICATION	OIL LUBRICATION
M6 P=1	0.45±0.05 (3.2±0.4)	0.38±0.04(2.7±0.3)	0.98±0.1 (7.1±0.7)	0.83±0.08 (6.0±0.6)	1.77±0.18 (12.8±1.3)	1.5±0.15 (10.8±1.1)	
M8 P=1.25	1.09±0.11 (7.9±0.8)	0.92±0.09 (6.6±0.7)	2.4±0.2 (17.3±1.4)	2.0±0.2 (14.4±1.4)	4.3±0.4 (31.0±2.9)	3.6±0.4 (26.0±2.9)	
M10 P=1.5	2.2±0.2 (15.9±1.4)	1.83±0.18 (13.2±1.3)	4.7±0.5 (33.9±3.6)	4.0±0.4 (28.9±2.9)	8.5±0.9 (61.3±6.5)	7.2±0.7 (52.0±5.1)	
M12 P=1.75	3.7±0.4 (26.7±2.9)	3.2±0.3 (23.1±2.2)	8.1±0.8 (58.5±5.8)	6.8±0.7 (49.1±5.1)	14.6±1.5 (105±10.8)	12.3±1.2 (88.8±8.7)	
M14 P=2	5.9±0.6 (42.6±4.3)	5.0±0.5 (36.1±3.6)	12.8±1.3 (92.5±9.4)	10.8±1.1 (78.0±7.9)	23±2 (166±14)	19.5±1.9 (140±14)	
M16 P=2	9.0±0.9 (64.9±6.5)	7.6±0.7 (54.8±5.1)	19.5±2.0 (140±14.4)	16.4±1.6 (118±11.5)	35±4 (252±28.9)	29±3 (209±21.6)	
M18 P=2.5	12.4±1.2 (89.6±8.7)	10.5±1.0 (75.8±7.2)	27±3 (195±22)	23±2 (166±14)	49±5 (354±36)	41±4 (296±29)	
M20 P=2.5	17.5±1.7 (126±12.3)	14.7±1.4 (106±10.1)	38±4 (274±29)	32±3 (231±22)	68±7 (491±51)	57±6 (412±43)	
M22 P=2.5	23±2 (166±14)	19.6±2.0 (142±14)	51±5 (368±36)	43±4 (310±29)	92±9 (663±65)	77±7 (555±58)	
M24 P=3	30±3 (217±22)	24±3 (173±22)	65±7 (469±51)	53±5 (383±36)	118±12 (852±87)	96±10 (693±72)	
M27 P=3	44±4 (318±29)	36±3 (260±22)	96±10 (693±72)	78±8 (563±58)	173±17 (1250±120)	140±14 (1010±100)	
M30 P=3.5	60±6 (433±43)	50±5 (361±36)	131±13 (946±94)	110±11 (794±79)	235±24 (1700±170)	198±20 (1430±140)	
M33 P=3.5	81±8 (585±58)	68±7 (491±51)	176±18 (1270±130)	148±15 (1070±110)	317±32 (2290±200)	266±27 (1920±200)	
M36 P=4	105±10 (758±72)	88±9 (636±65)	227±23 (1640±170)	190±19 (1370±140)	343±34 (2480±250)	343±34 (2480±250)	

TORQUE VALUE UNIT– kgf-m (ft. lbs.)

2. Metric Fine Thread Standard Tightening Torque Values. Make certain to tighten all Capscrews & Nuts to proper torque values.

Classification	4	T		10		T	
		NO LUBRICATION	OIL LUBRICATION	NO LUBRICATION	OIL LUBRICATION	NO LUBRICATION	OIL LUBRICATION
M8 P=1.0	1.15±0.11 (8.3±0.8)	0.97±0.1 (7.0±0.7)	2.5±0.2 (18.0±1.4)	2.1±0.2 (15.2±1.4)	4.5±0.4 (32.5±2.9)	3.8±0.4 (27.4±2.9)	
M10 P=1.25	2.3±0.2 (16.6±1.4)	1.91±0.19 (13.8±1.4)	4.9±0.5 (35.4±3.6)	4.2±0.4 (30.3±2.9)	8.9±0.9 (64.2±6.5)	7.5±0.7 (54.2±5.1)	
M12 P=1.25	4.0±0.4 (28.9±2.9)	3.4±0.3 (24.5±2.2)	8.7±0.9 (62.8±6.5)	7.3±0.7 (52.7±5.1)	15.7±1.6 (113±13)	13.2±1.3 (95.3±9.4)	
M16 P=1.5	9.4±0.9 (67.9±6.5)	7.9±0.8 (57.0±5.8)	20±2 (144±14)	17.2±1.7 (124±12)	37±4 (267±29)	31±3 (224±22)	
M20 P=1.5	19±9 (137±14)	15.8±1.6 (114±14)	41±4 (296±29)	34±3 (246±22)	74±7 (535±51)	62±6 (448±43)	
M24 P=2	32±3 (231±22)	27±3 (195±22)	70±7 (506±51)	58±6 (419±43)	126±12 (910±87)	105±10 (758±72)	
M30 P=2	65±6 (469±43)	54±5 (390±36)	142±14 (1030±100)	118±12 (852±87)	255±26 (1840±190)	212±21 (1530±150)	
M36 P=3	109±11 (787±79)	91±9 (657±65)	238±23 (1720±170)	198±20 (1430±140)	428±43 (3090±310)	357±36 (2580±260)	

TORQUE VALUE UNIT– kgf-m (ft. lbs.)

Section VII- SCHEMATICS

B. SK70SR ELECTRIC CIRCUIT DIAGRAM (B)

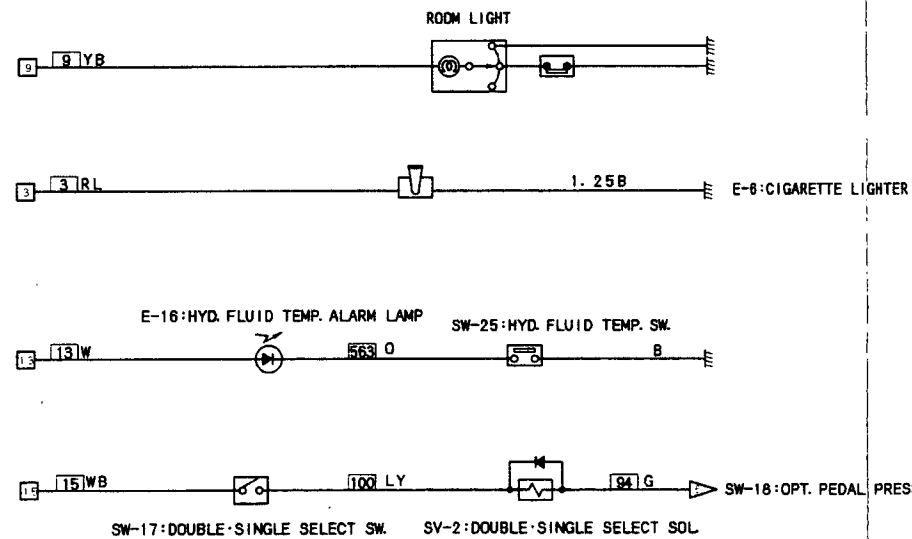
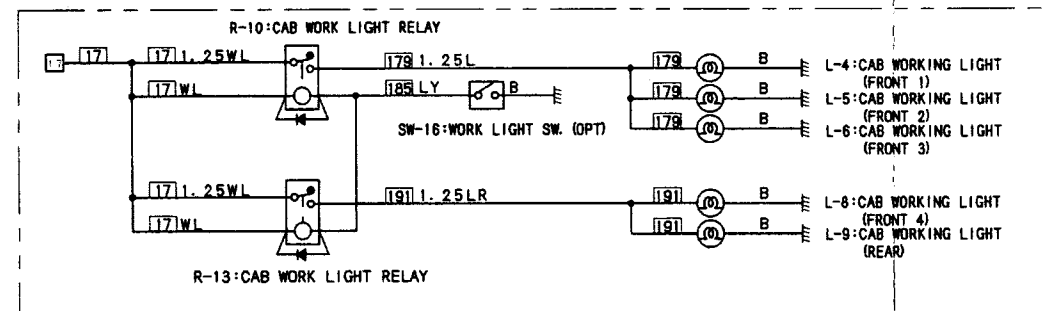
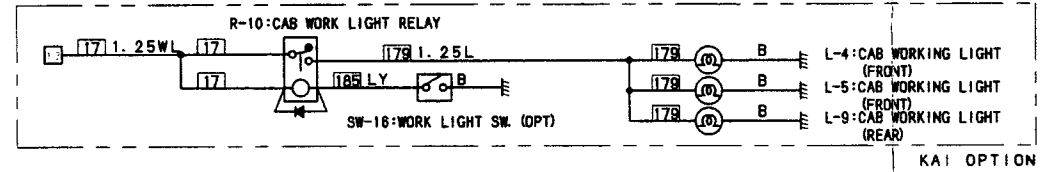
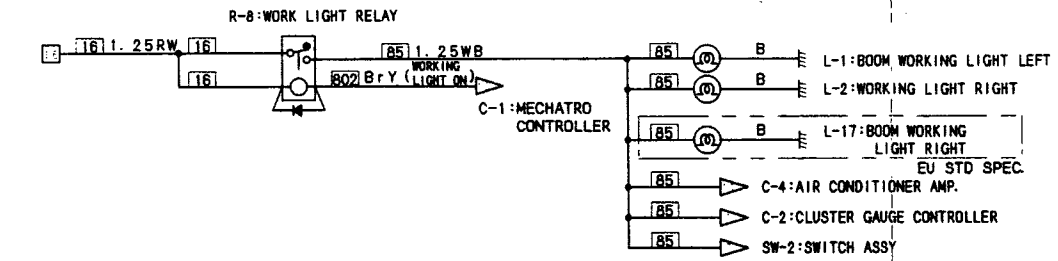
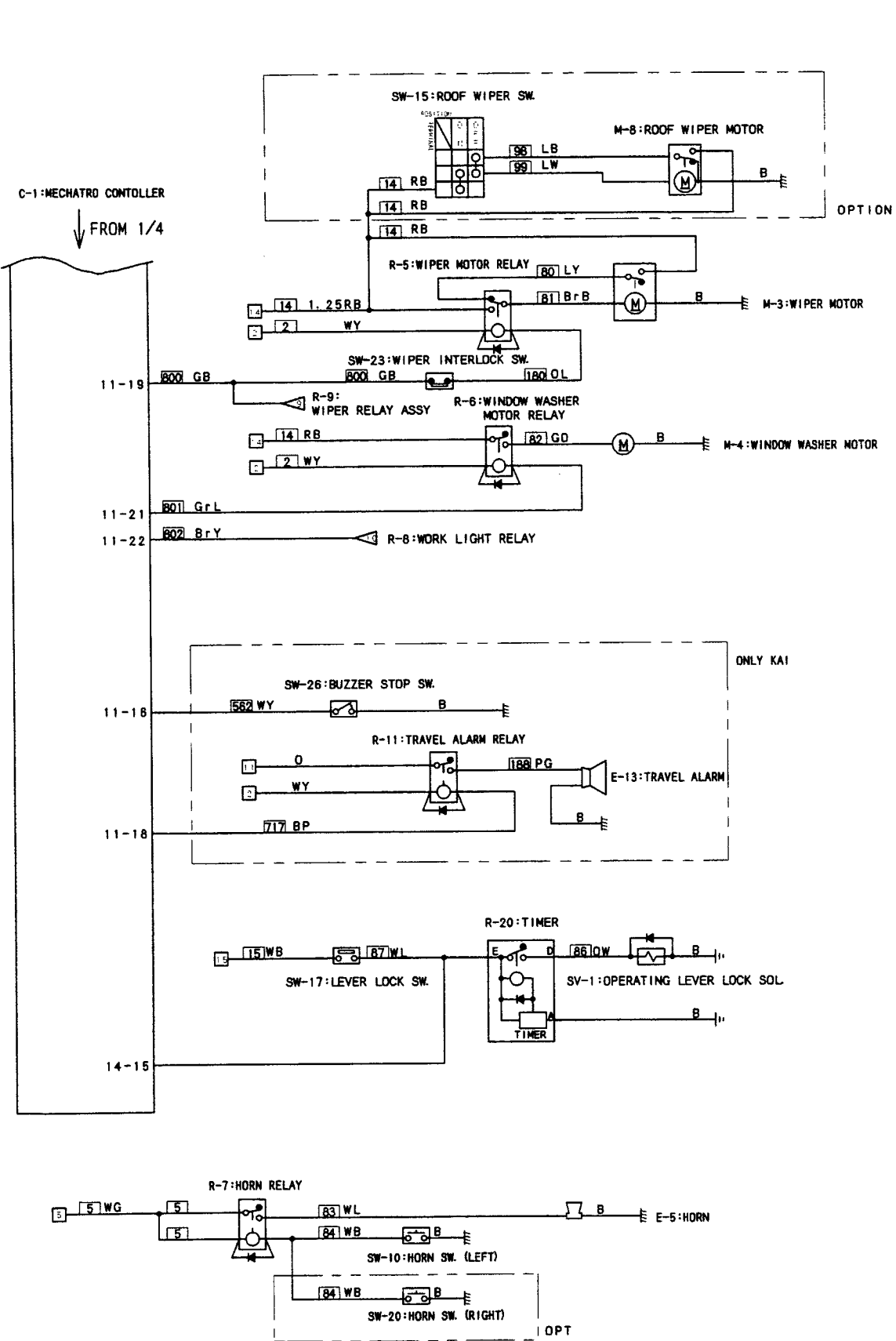

Section VIII– OPTIONAL EQUIPMENT

8.5 EXTRA (GRAPPLE, CLAMSHELL, ETC) AND EXTRA & BREAKER

A. BASIC OPERATION



WARNING



READ, UNDERSTAND AND FOLLOW ALL SAFETY PRECAUTIONS AND OPERATION PROCEDURES FOUND IN THIS MANUAL BEFORE OPERATING THE MACHINE OR ANY ATTACHMENT.

1. Start Machine and place the Safety Lock Lever in the "UNLOCKED" (Down) position. See Figure 8.17.
2. Move throttle control to the "HI" idle position.
3. Using Boom, Arm and Bucket controls set the Attachment to desired position.
4. Use the Boom, Arm and Bucket Controls to position the attachment.
5. Place Right foot on pedal and depress with toe to close attachment and depress back of pedal with heel to open attachment. See Figure 8.18.
6. After operation is complete or operator is required to leave the machine, place pedal lock rod in the locked position, See Figure 8.18, position attachment in hydraulic oil check position, move throttle control to "LO" idle position.

Supplementary Explanation

For machine provided in extra & breaker specification, before starting operating, unlock left control pedal. See Figure 8.18.



WARNING



NEVER LEAVE THE OPERATOR CAB WITH ENGINE RUNNING.

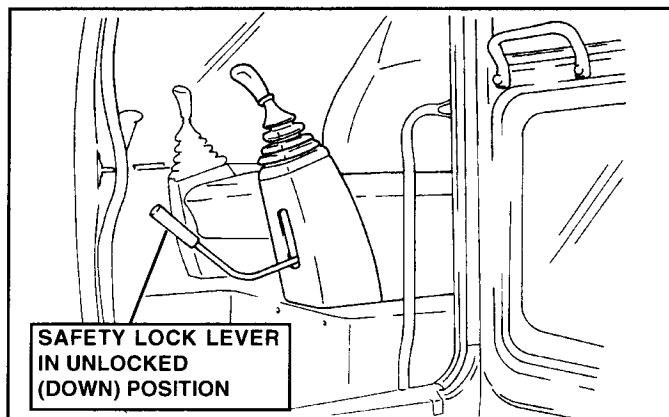

FIGURE 8.17

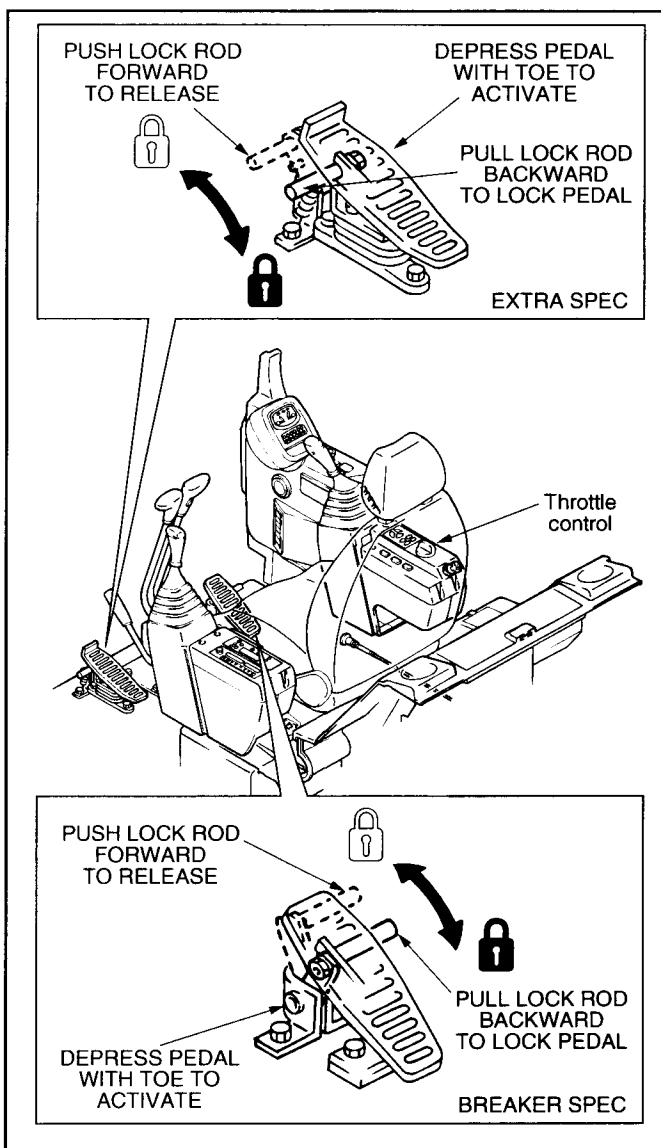

FIGURE 8.18

Section IX- SPECIAL PROCEDURES

9.1 GENERAL

The SK70SR machine incorporates automatically applied spring brake systems in the travel motors and swing motors. These systems will automatically engage the brakes when engine is stopped making it impossible to move the machine. This section contains the required procedures for releasing the travel motor brakes, the swing motor brake and lowering the attachment to the ground should sudden engine failure be experienced.

WARNING

READ, UNDERSTAND AND FOLLOW ALL SAFETY PRECAUTIONS AND PROCEDURES FOUND IN THIS MANUAL BEFORE ATTEMPTING ANY OPERATION, INSPECTION, MAINTENANCE OR REPAIR OF THIS MACHINE, ATTACHMENT OR ANY OF ITS SYSTEMS.

WARNING

THE PROCEDURES FOUND IN THIS SECTION SHOULD BE PERFORMED BY A WELL TRAINED EXPERIENCED SERVICE TECHNICIAN WHO IS FAMILIAR WITH THE KOBELCO SK70SR MACHINES.

9.2 RELEASING TRAVEL MOTOR BRAKES

A. Tools & Equipment Required

1. Four (4) Chock Blocks.
2. One (1) Allen wrench for Drain plug.
3. Hammer and Punch one each.
4. Drilling device for 2mm diameter.
5. Two (2) 3.4 Liter (0.9 Gal) capacity drain pans.
6. Thread sealant. (For Drain and Check/Fill Plugs)
7. Rubber or Soft Faced Mallet.

B. Procedures

NOTE

Make sure to align the plugs on the Travel Motor Covers perpendicular to the ground, as shown on Figure 9.3, before shutting off the engine.

1. Place Chock Blocks at Front and Rear of each track to prevent machine from moving when brakes are released. See Figure 9.1.

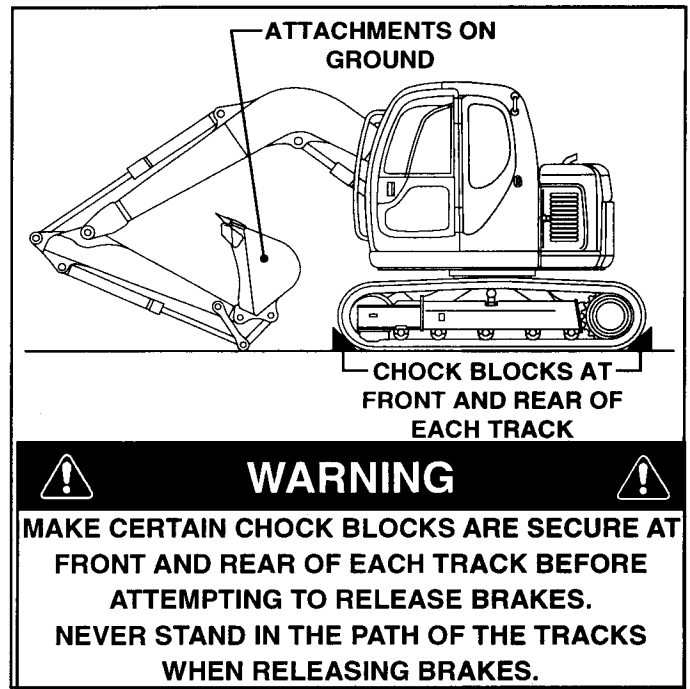

FIGURE 9.1

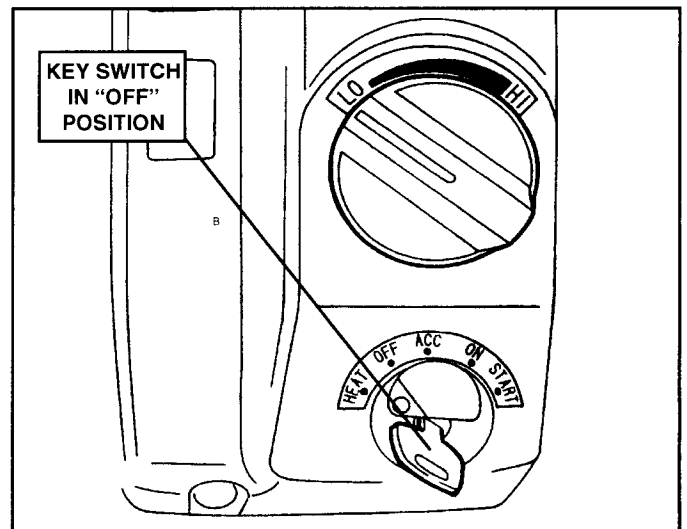

FIGURE 9.2

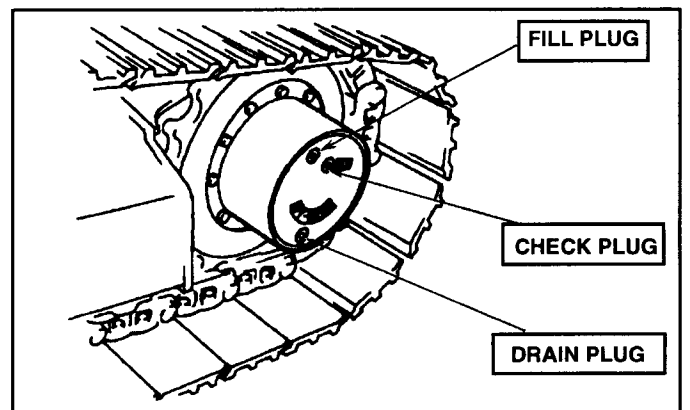

FIGURE 9.3

CLICK HERE TO **DOWNLOAD** THE COMPLETE MANUAL

- Thank you very much for reading the preview of the manual.
- You can download the complete manual from: www.heydownloads.com by clicking the link below



- Please note: If there is no response to CLICKING the link, please download this PDF first and then click on it.

CLICK HERE TO **DOWNLOAD** THE COMPLETE MANUAL