



93217-00210
March 2012

135ZV-2

SHOP MANUAL

Disassembly & Reassembly
Service Standard

SHOP MANUAL

WHEEL LOADER

135ZV-2

***Disassembly & Reassembly
Service Standard***

Powered by CUMMINS QST30-C ENGINE

Serial No. 13C1-9501~

93217-00210

CLICK HERE TO **DOWNLOAD** THE COMPLETE MANUAL

- Thank you very much for reading the preview of the manual.
- You can download the complete manual from: www.heydownloads.com by clicking the link below



- Please note: If there is no response to CLICKING the link, please download this PDF first and then click on it.

CLICK HERE TO **DOWNLOAD** THE COMPLETE MANUAL

Unloader Valve	54-10
Unloader valve removing and installing	54-10
Unloader valve disassembling and assembling	54-12
Manifold Valve Assembly	54-14
Valve assembly removing and installing	54-14
Valve assembly disassembling and assembling	54-16
Accumulator	54-17
Accumulator removing and installing	54-17
Accumulator disassembling and assembling	54-19
Nitrogen gas charging	54-25
Service Brake	54-27
Service brake disassembling and assembling	54-27
Parking Brake	54-31
Parking brake removing and installing	54-31
Parking brake disassembling and assembling	54-32
135ZV-2 Service Standard Brake Group	55-1
Brake Valve	55-2
Service Brake	55-4
Parking Brake	55-5
135ZV-2 Disassembly & Reassembly Operator Station Group	74-1
Air Conditioner	74-2
Air conditioner removing and installing	74-2
Air conditioner disassembling and assembling	74-4
135ZV-2 Service Standard Operator Station Group	75-1
Air Conditioner	75-2
Periodical Inspection/Serviceing	75-2
Tightening Torque	75-2

Screw lock agent application procedure

Through-hole

Apply screw lock agent one or two lines on the male threads.

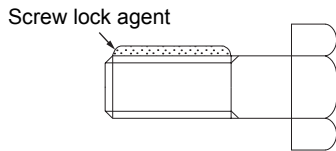

65ZV00002

How to wind a seal tape

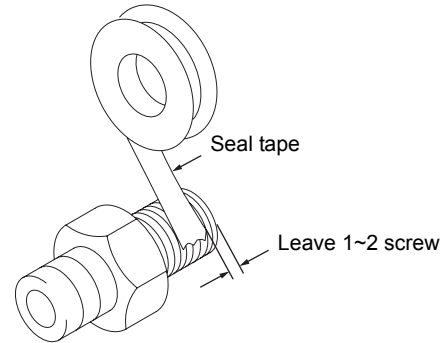

65ZV00004a

As the screw is tightened by turning clockwise, seal tape must be wound up clockwise direction as shown above. If not, the tape will be loosened or removed while tightening the screw, resulting in oil leakage.

To avoid a piece of seal tape left in the circuit, leave 1 or 2 screws from the end of the thread and start threading it clockwise.

Slightly stretch the tape when cutting it out, and press to fit the tape onto the screw thread.

Fuel Tank

Fuel tank removing and installing

Fuel tank removing

WARNING

Unexpected movement of the machine could cause an accident resulting in injury or death. Be sure to observe the following items before starting fuel tank removal:

- Position the machine on level ground, and apply the parking brake.
- Lower the attachment onto the ground, and block the tires with chocks, etc. to prevent them from moving.
- Remove the engine key, and hang a "DO NOT START ENGINE!" tag on the operation board.

Before starting work:

- Drain fuel from the fuel tank.
(Fuel tank capacity: 1,050 L (280 gal))
- Remove the right side deck.

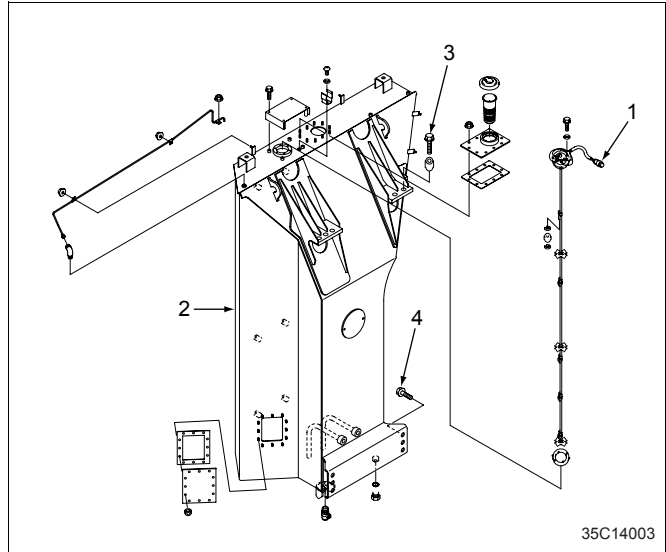

1. Disconnect level sensor electrical line coupler (1).

2. Temporarily sling fuel tank (2).

 : Fuel tank: 610 kg (1,345 lbs) (when empty)

3. Remove retainer bolts (3)(4).

 : Bolt (3)(4): 765 N-m (78.0 kgf-m) (564 lb-ft)

14-14
 135ZV-2 Disassembly & Reassembly Chassis Group
 Cab

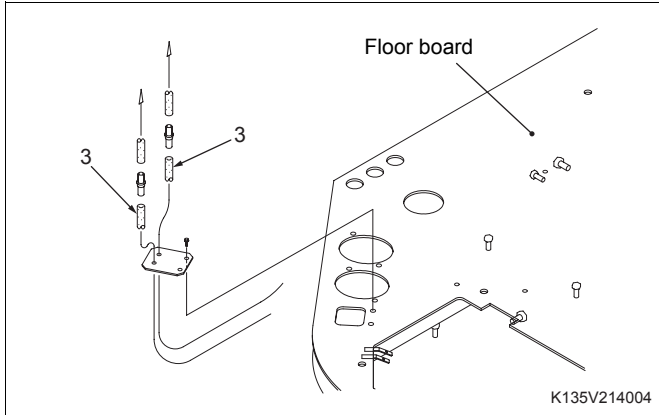

3. Disconnect hoses (3) for the window washer liquid at the floor board.

Note

Cover the disconnected hoses with vinyl to protect them from dust and dirt.

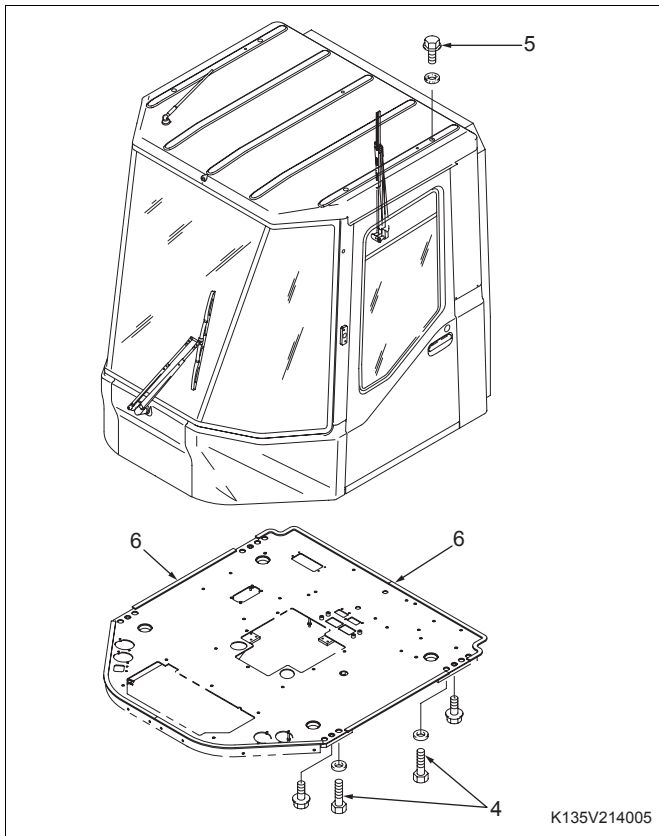

4. Remove bolt (4) with plain washer.

 : Bolt (4): 721 N-m (73.5 kgf-m) (532 lb-ft)

5. Remove bolt (5) and install the eye bolt (M24 x 3.0) on the cab instead.
 Attach sling and remove the cab slowly.

 : Cab: 335 kg (740 lbs)

Cab installing

For reinstallation, follow the above procedure in reverse order.

Cab installation cautions

- Check the movement of the wiper and adjust the moving angle, if needed.
- Tune the clock and the radio.
- Apply the antiseize agent (Loctite® 767) between sponges (6) and the floor board (on the floor board side).

Center pin removing and installing

Center pin removing

⚠ WARNING

Unexpected movement of the machine could cause an accident resulting in injury or death. Be sure to observe the following items before starting center pin removal:

- Place the machine on level and paved ground.
- Lower the attachment onto the ground, and block the front tires with chocks, etc. to prevent them from moving.
- Apply the stopper to the rear wheel oscillation section to prevent the machine from oscillation.
- Release the residual pressure from the hydraulic line, and also release the internal pressure from the hydraulic tank.
- Cover the steering cylinder rod to prevent it from being scratched.

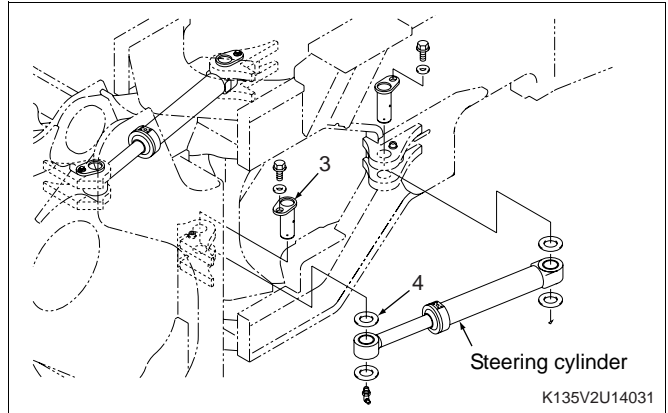

2. Remove right and left steering cylinder retainer pins (3) and shims (4).
 Inspect them for wear or damage, and replace if necessary.

Note

Wrap the steering cylinder rods to prevent accidental damage to the chrome rods.

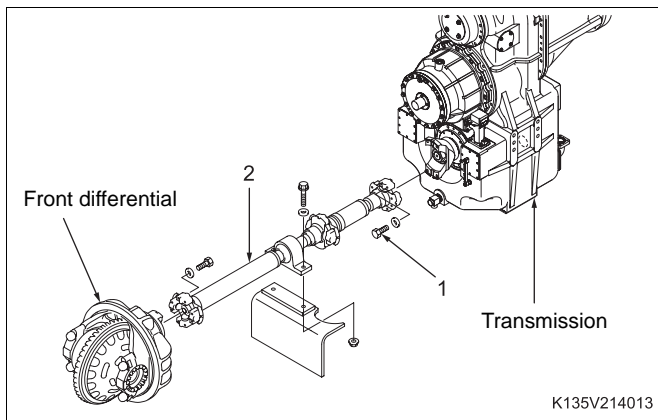

1. Remove bolt (1) and disconnect second propeller shaft (2) from the transmission.

- : Bolt (1): 221 N-m (22.5 kgf-m) (163 lb-ft)
- : Screw lock agent (Loctite® 262) application

Note

If the retainer bolt is too tight due to the screw lock agent, heat the bolt head using slow flame of a gas burner to about 235 °C (450 °F).

Keep the flame away from the seals of the coupling.
 Do not reuse the bolts, and always replace with new ones.

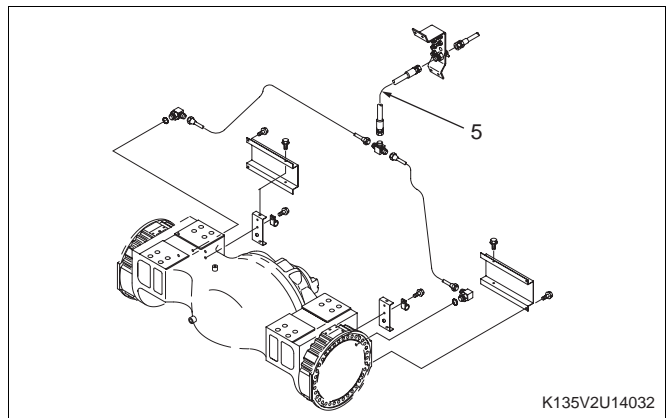

3. Remove brake line hose (5) at the front chassis.

: Brake line oil: Approx. 2 L (0.5 gal)

Note

Cover the disconnected hoses with vinyl to protect them from dust and dirt.

Center Pin

Center pin shim adjustment

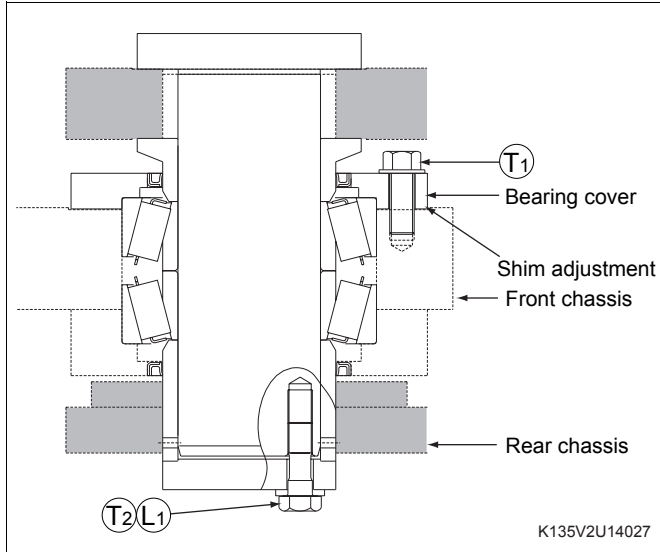

The clearance between the front chassis and bearing cover is 0.75 ± 0.5 mm (0.0295 ± 0.0197 in) before shim adjustment.

Add shims so that the clearance is 0.1 ± 0.05 mm (0.0039 ± 0.0020 in).



T_1 : 721 N-m (73.5 kgf-m) (532 lb-ft)

T_2 : 1,128 N-m (115 kgf-m) (832 lb-ft)



L_1 : With lubrication oil (Engine oil or gear oil)

Bearing cover installing

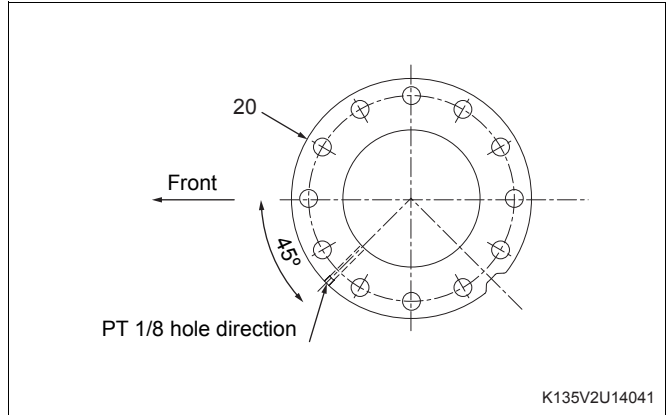

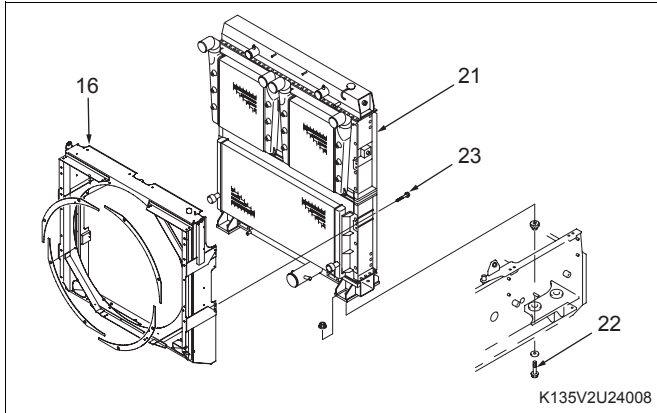

Install bearing cover (20) so that the PT 1/8 hole is positioned at the specified angle as shown in the figure above.



Radiator installing

For reinstallation, follow the above procedure in reverse order.

8. Temporarily sling radiator (21) with duct (16). Remove retainer bolt (22), and lift the radiator assy (21). Take out the radiator backward while taking care not to interfere the parts and units around, such as fan.

 : Bolt (22): 441 N-m (5.0 kgf-m) (36 lb-ft)
 : Radiator assy: 970 kg (2,140 lbs)
 : Duct assy: 105 kg (230 lbs)

Note

Radiator assy (21) with duct (16) should be slightly tilted back while being slung up to remove from the rear chassis. In order to avoid any damage or for easier work, you may remove the fan from the engine beforehand.

If you remove duct (16) before taking out radiator assy (21), remove fan, and then, remove bolt (23) to separate duct (16) from radiator assy (21).

Refer to "Fan" pages to remove the fan.

Propeller shaft installing

For reinstallation, follow the above procedure in reverse order.

Propeller shaft installation cautions

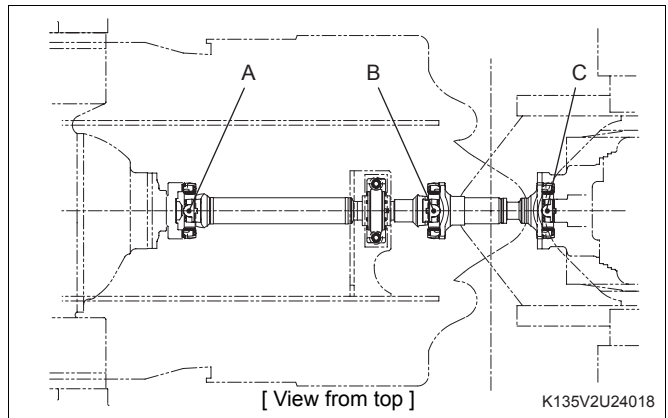

- When reinstalling the second propeller shaft, make sure the center of three flange yokes (points A, B and C) are aligned straight. (Also refer to the figure on page 24-11)

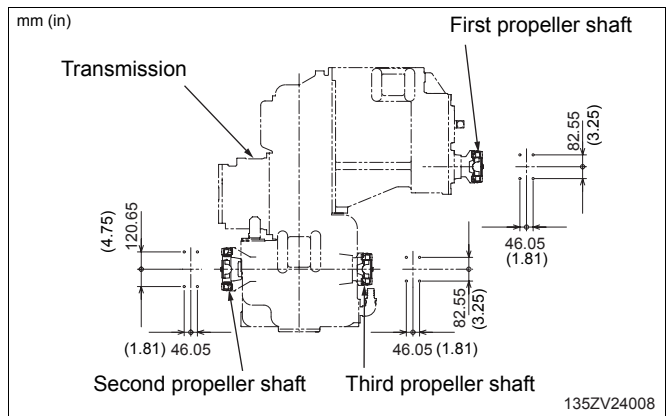

- During reinstallation, align the direction of the flange yokes on the second and third propeller shaft sides of the transmission. (Refer to 135ZV-2 Shop Manual, Function and Structure, Section 22.)
[Difference in the yoke phase (direction) will cause the propeller shaft damage and "knocking" during a turn.]
- Clean all threads with a primer before applying the screw lock agent (Loctite® 262). This assures the quicker and stronger bonding.
- Align the grease nipples of the propeller shafts so that they face to the same direction.

24-26
 135ZV-2 Disassembly & Reassembly Power Group
 Front Axle Assembly

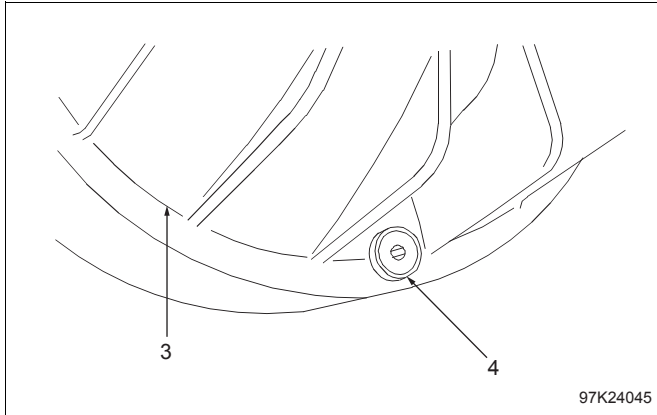

3. Turn drain plug (4) to the bottom of wheel hub (3) to drain oil.

 : Gear oil: Approx. 70 L (18.5 gal)

Note



To replace the oil, refer to the oil amount described below.

Wheel hub section:
 50 L (13 gal) for left side,
 50 L (13 gal) for right side

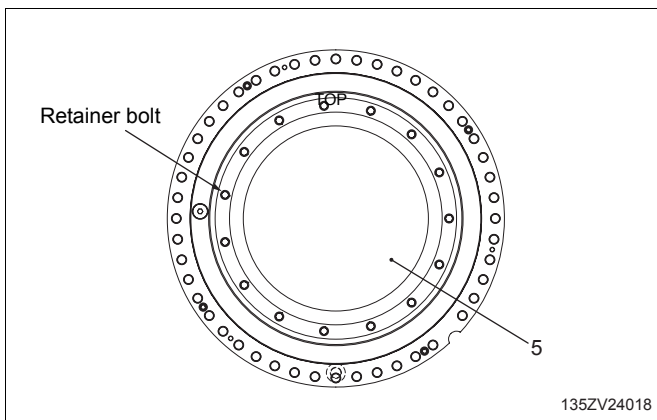
Differential section (front): 220 L (58 gal)
 Total oil amount for front axle: 320 L (85 gal)



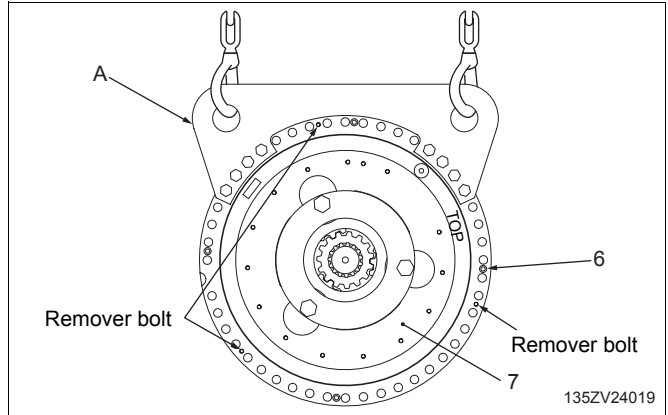

4. Remove cover (5).

 : Cover bolt: 94 N-m (9.6 kgf-m) (69 lb-ft)
 : Screw lock agent (Loctite® 262) application



5. Temporarily sling the spider using hoisting tool (A). Remove spider retainer bolts (6) (7 pcs) and install remover bolts to remove spider assembly (7).

 : Bolt (6): 86 N-m (8.8 kgf-m) (64 lb-ft)
 : Spider assembly: 525 kg (1160 lbs)

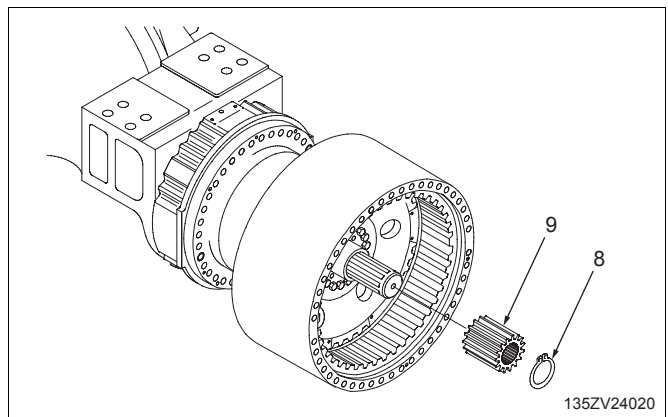

6. Remove snap ring (8), and remove sun gear (9).

24-36
135ZV-2 Disassembly & Reassembly Power Group
Special Tool

(D) Bearing insertion tool
mm (in)

(Material: SS41)

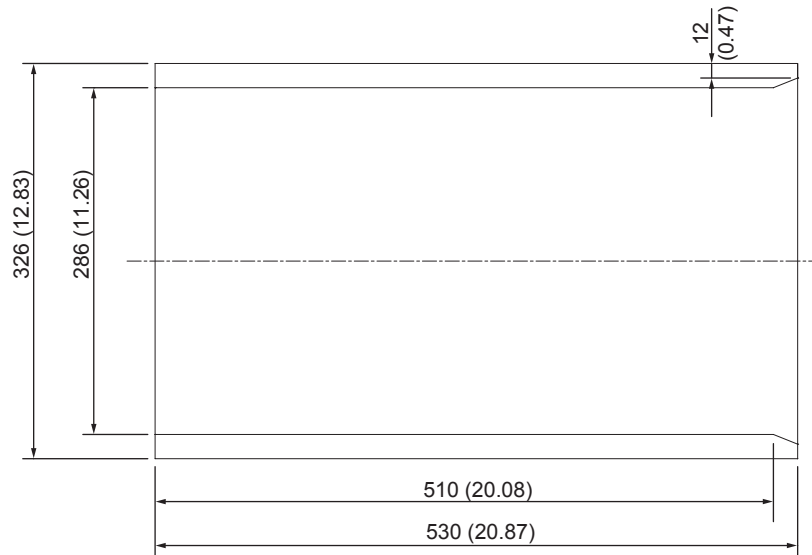

135ZV24041

Axle support assembly cautions

IMPORTANT

- Replace all the O-rings and seals with new ones.
- Clean and check all the parts. If a part is damaged, replace it.

Bushing installation

[Front axle support]

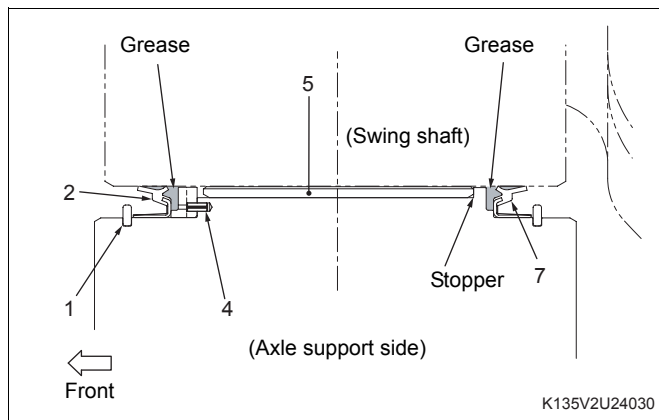

- Before installing, put bushing (5)(16) into dry ice. Install cooled bushing (5)(16) to the front axle support and the rear axle support, respectively, as shown in the illustration. After installing, be sure to press bushing (5)(16) until stopped by the stopper of the axle support.

Note

- The side with a groove on bushing (16) should come to the rear side.
 The side with a groove on bushing (16) should come to the rear side.

[Rear axle support]

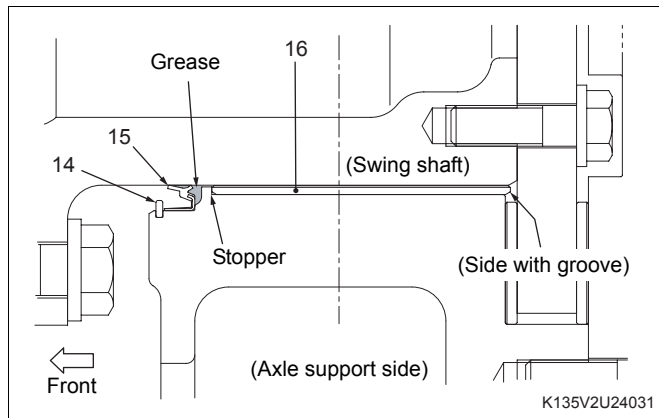

IMPORTANT



When installing the bushing onto the axle support, make sure no oil is left on the outer surface of the bushing or the axle support surface. If oil is left on them, the bushing may turn alone causing the bushing and axle support wear.

- Carefully install the axle support onto the swing shaft.
- Avoid damage to lip seal packings (2)(7)(15).
- When installing the axle support, fill enough grease between the packing and the axle support as shown in the illustration.

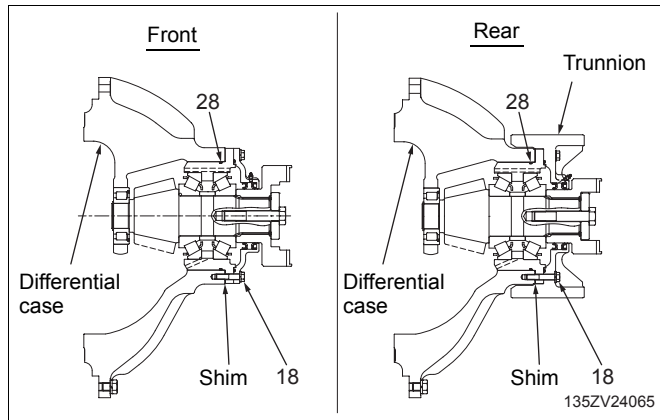
Shim adjustment



1. Install O-ring (28) and the shims (the one(s) removed during disassembly) to the cage.
2. Insert the cage into differential case, and tighten retainer bolt (18) temporarily.
3. After adjusting tooth contact, tighten bolts (18) with the specified tightening torque.

 : Bolt (18): 314 N-m (32.0 kgf-m) (232 lb-ft)
 : Screw lock agent (Loctite® 262) application

Note

Shims should be selected to adjust the tooth contact. For adjusting tooth contact, refer to "Adjusting tooth contact".

Backlash adjustment

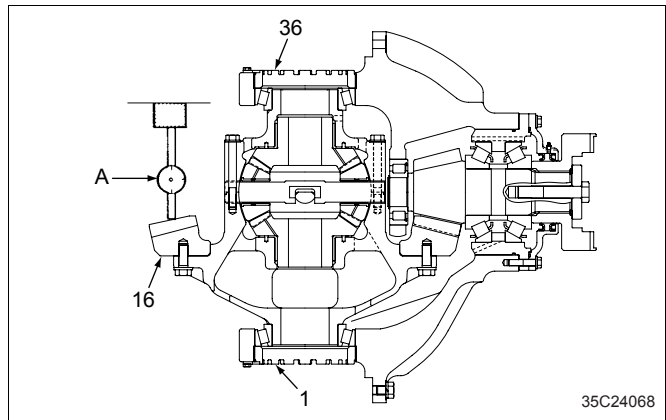

Adjust the backlash as follows:

1. Tighten adjustment nut (1) on the bevel gear side until the backlash is "0". Then back off the adjustment nut 2 to 3 notches.
2. Tighten opposite side adjustment nut (36). After you feel that the nut is tight, turn it one more notch.
3. Attach the dial gauge stand to the carrier. Attach dial gauge (A) to a tooth of bevel gear (16). Read the backlash value indicated on the dial gauge.
4. Adjust the backlash.

Standard backlash:
 0.46~0.66 mm (0.018~0.026 in)

- Tighten adjustment nut (1) on the bevel gear side or loosen adjustment nut (36) on the opposite side to reduce the backlash.
- Loosen adjustment nut (1) on the bevel gear side or tighten adjustment nut (36) on the opposite side to increase the backlash.

Torque Converter and Transmission Assembly

Torque converter and transmission assembly tightening torque

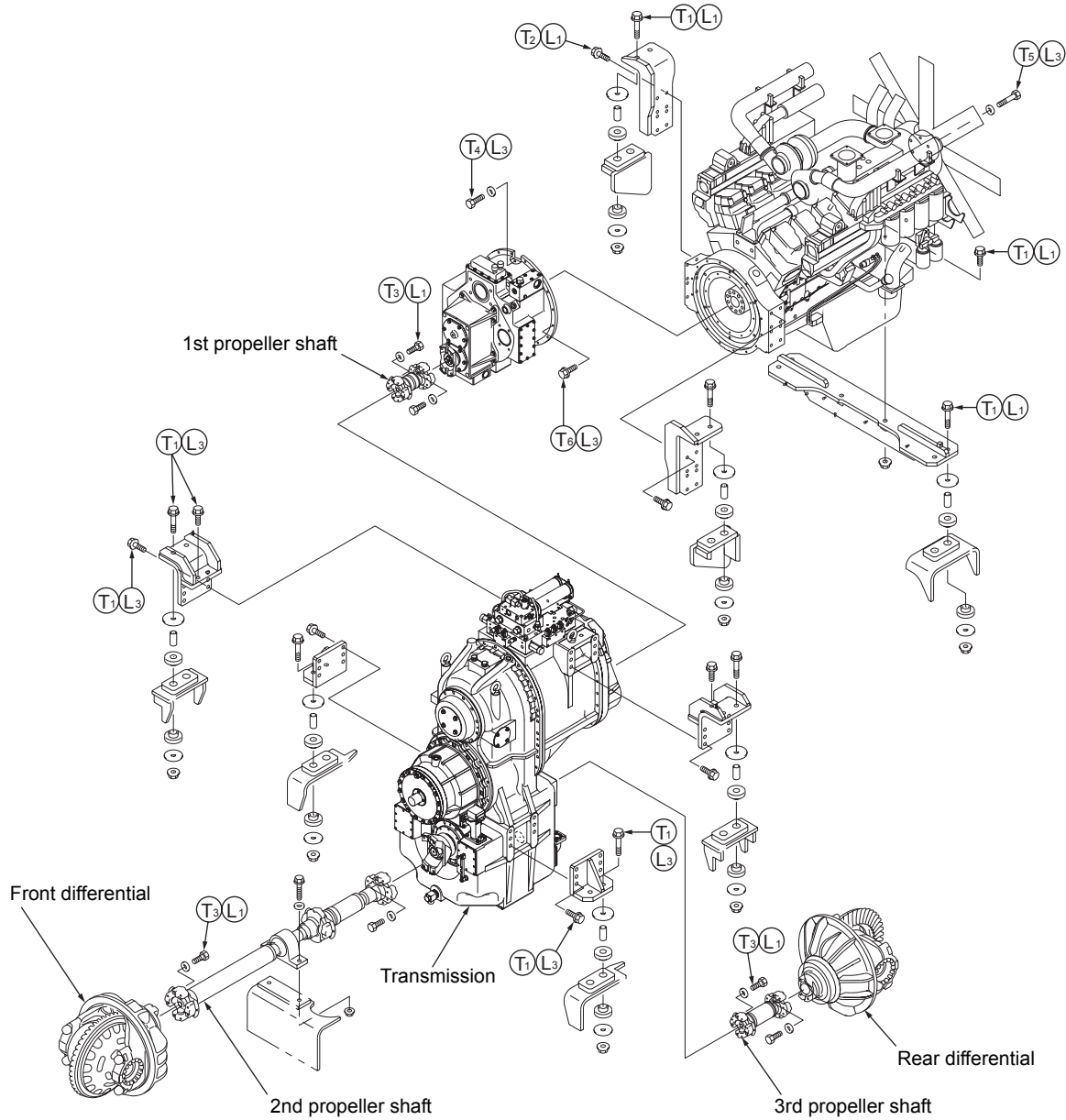

K135V224001



- T₁: 765 N-m (78 kgf-m) (564 lb-ft)
- T₂: 441 N-m (45 kgf-m) (325 lb-ft)
- T₃: 221 N-m (22.5 kgf-m) (163 lb-ft)
- T₄: 196 N-m (20 kgf-m) (145 lb-ft)
- T₅: 97 N-m (9.9 kgf-m) (72 lb-ft)
- T₆: 94 N-m (9.6 kgf-m) (69 lb-ft)



- L₁: Screw lock agent (Loctite® 262)
- L₃: With lubrication oil (Engine oil or gear oil)

Always replace drive shaft bolts with new ones - never reuse them.

Note

The bolt (T₅) and the washer installing the fan to the engine are the accessory parts of the engine.

34-12

135ZV-2 Disassembly & Reassembly Torque Converter and Transmission Group
Torque Converter Assembly

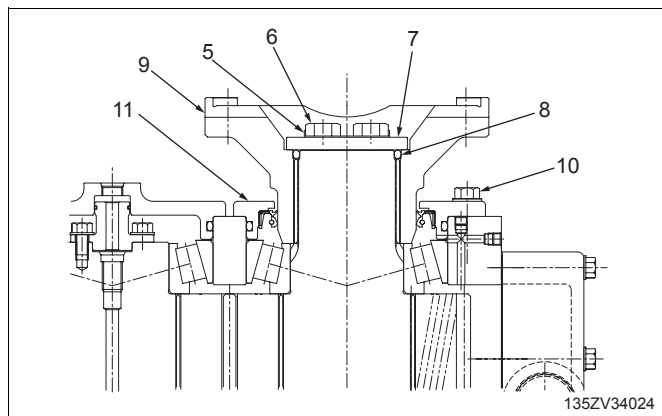

- Clinch the three edges of lock plate (5) after tightening bolts (6) to fasten the bolts (6) for turbine shaft fixing plate (7).
- After reassembling the torque converter assembly, check that the drive cover turns smoothly.

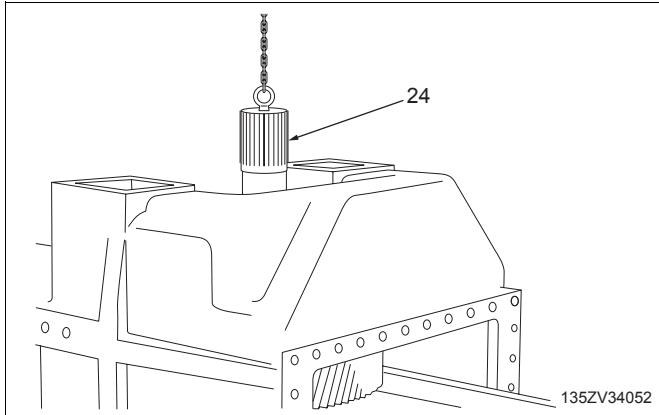

18. Pull out output shaft (24).

 : Output shaft: 55 kg (115 lbs)

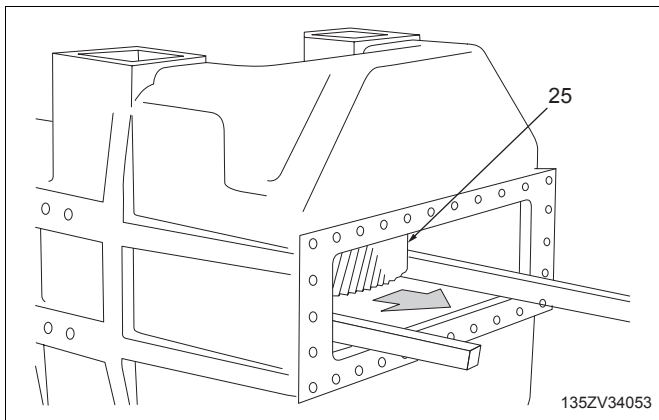

19. Slide gear (25) on the iron bars and pull it out to remove.



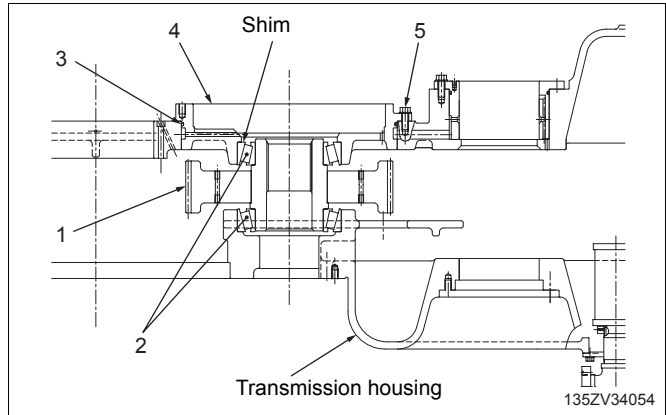

 : Gear: 160 kg (350 lbs)

Transmission assembly assembling

For reassembling, follow the above procedure in reverse order.



1. Install taper roller bearing (2) to gear (1), and install it to the transmission housing. Then, install the shim, O-ring (3), housing (4) to taper roller bearing (2), and tighten bolt (5).

-  : Bolt (5): 230 N-m (23.5 kgf-m) (170 lb-ft)
-  : With lubricating oil (engine oil or gear oil)
-  : Gear (1): 150 kg (325 lbs)
-  : Housing (4): 90 kg (200 lbs)

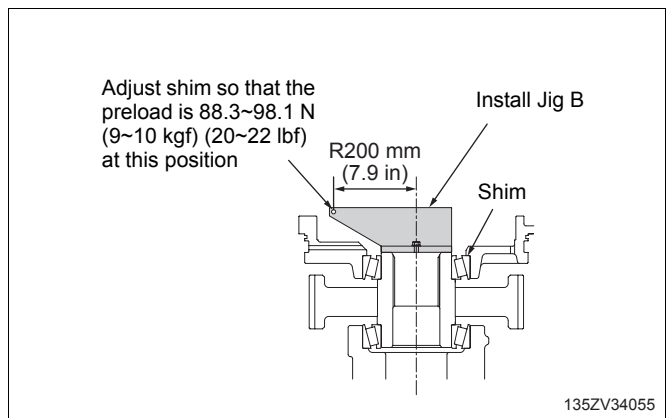

Note

If taper roller bearing (2) is replaced with a new one, install Jig B and adjust the preload by selecting a proper shim as illustrated.

Shim thickness:
0.1, 0.2, 0.3 mm (0.004, 0.008, 0.012 in)

34-32

135ZV-2 Disassembly & Reassembly Torque Converter and Transmission Group
Clutch Assembly

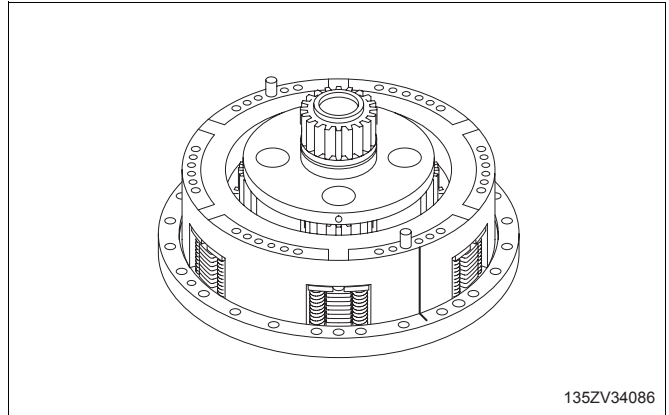
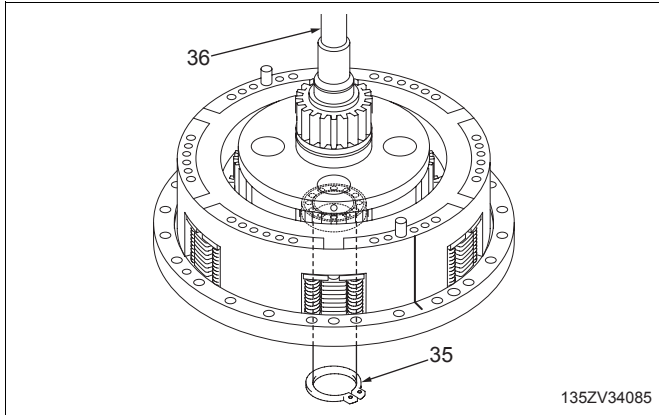

17. Remove snap ring (35) from shaft assembly (36), and then, pull out shaft assembly (36).

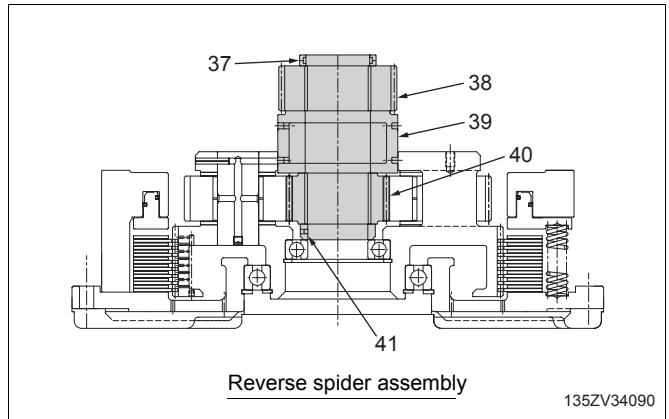
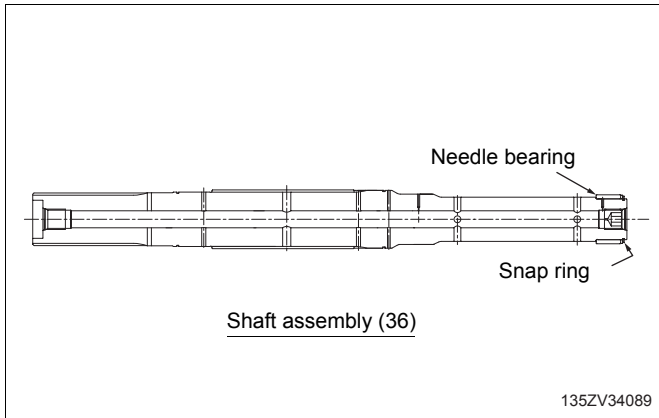

18. Remove ring (37), sun gear (38), ring (39), sun gear (40) and ring (41) from the reverse spider assembly.

Note

Remove each installed part from shaft assembly (36).

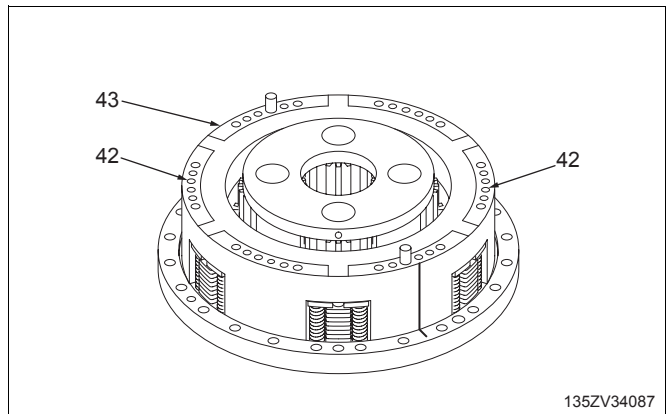

19. Remove two socket bolts (42) and reverse clutch housing (43).

- : Bolt (42): 127 N-m (13.0 kgf-m) (93.7 lb-ft)
- : With lubricating oil (engine oil or gear oil)

Note

Put matchmarks to the socket bolt holes.

CLICK HERE TO **DOWNLOAD** THE COMPLETE MANUAL

- Thank you very much for reading the preview of the manual.
- You can download the complete manual from: www.heydownloads.com by clicking the link below



- Please note: If there is no response to CLICKING the link, please download this PDF first and then click on it.

CLICK HERE TO **DOWNLOAD** THE COMPLETE MANUAL



Clutch Spider Assembly

Forward and 3rd clutch spiders disassembling and assembling

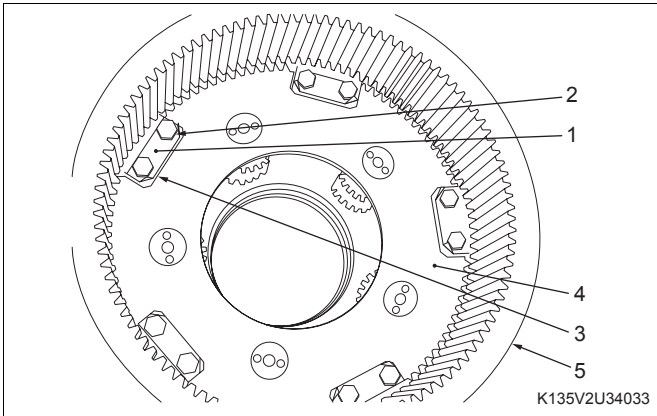
Forward and 3rd clutch spiders disassembling



1. Release calked lock plate (1) and remove bolt (2). Remove lock plate (1) and plate (3). Separate spider assembly (4) from internal gear (5).

 : Bolt (2): 132 N-m (13.5 kgf-m) (98 lb-ft)
 : With lubricating oil (engine oil or gear oil)

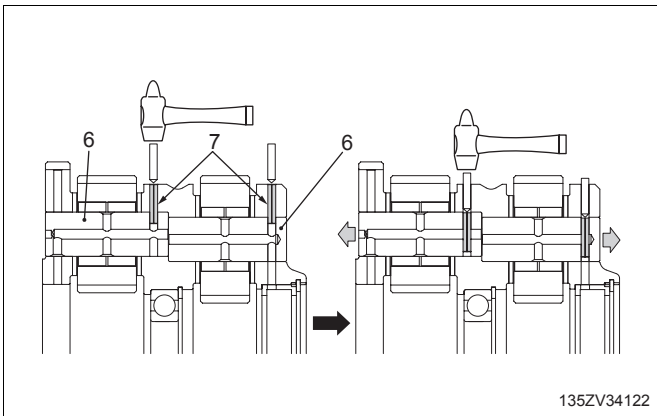

2. Knock in spring pin (7) that locks pin (6) all the way to unlock pin (6). Pull out pin (6).

Note

After removing pin (6), take spring pin (7) out of pin (6).

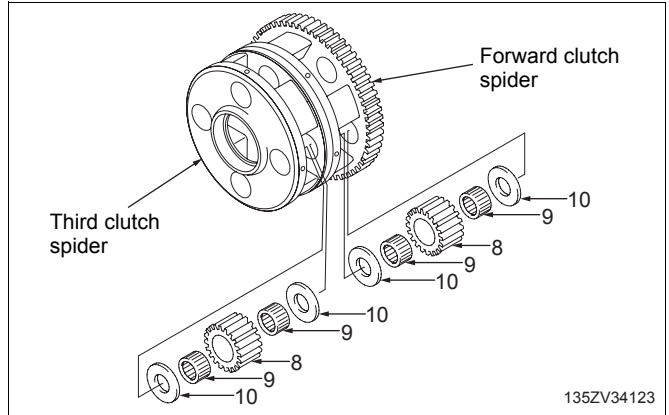

3. Remove planetary gears (8), needle bearings (9) and washer (10).

Note

The number of planetary gear (8) is as follows:
 On the forward clutch spider side: 5 pcs.
 On the 3rd clutch spider side: 4 pcs.

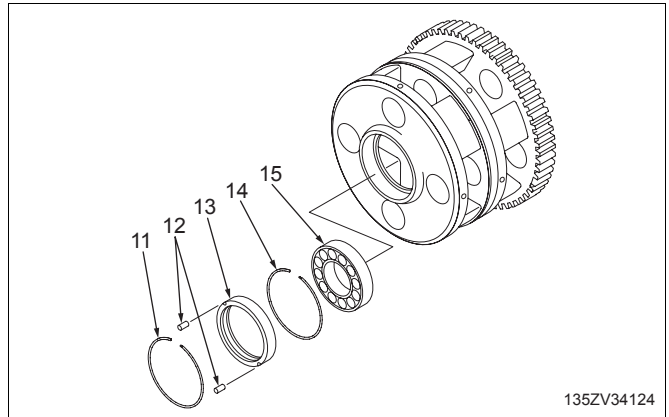

4. After removing snap ring (11) and two pins (12), remove bushing (13).

Note

Be careful not to lose pin (12).

5. Remove snap ring (14) and remove bearing (15) from the spider assembly.

Input gear box assembling

To reassemble the input gear box, follow the procedure described above in reverse order.

Before starting work:

- Clean and inspect each part, and replace any, if necessary.
For inspection and wear standard, refer to Section 35.
- Replace the bearing with new one, if necessary.
- Manually turn the bearing to check the bearing rotates properly.
- Be sure to apply the transmission oil to the necessary points when reassembling the input gear box.

Input gear box assembly cautions

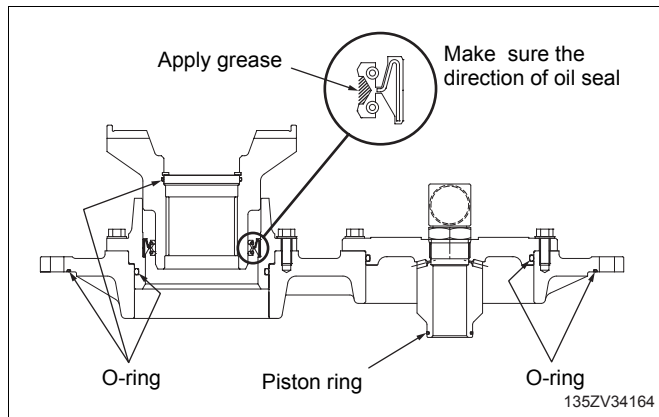

1. Install O-ring, oil seal and piston ring in the described positions.

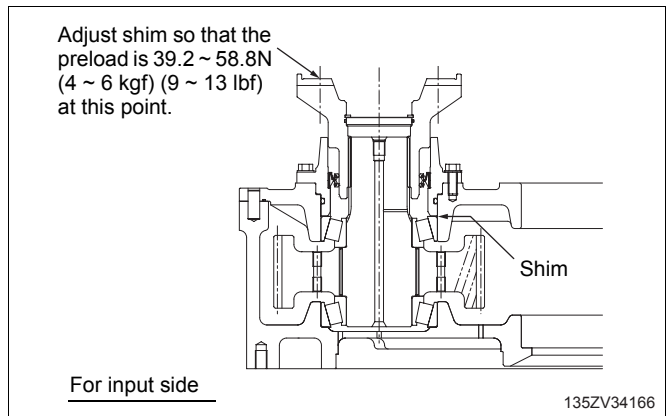
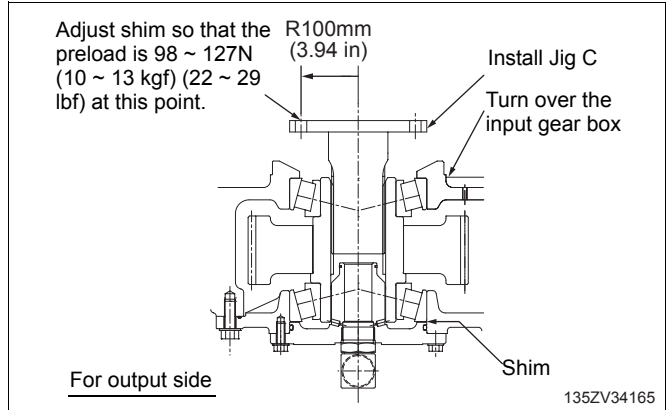

2. When the taper roller bearing is to be replaced with a new one, install Jig C and adjust the preload by selecting a proper shim as illustrated.
Shim thickness: 0.1, 0.2, 0.3 mm (0.004, 0.008, 0.012 in).

Note

Measure the preload of the taper roller bearing without engaging the gear teeth.

Transmission Assembly

Transmission

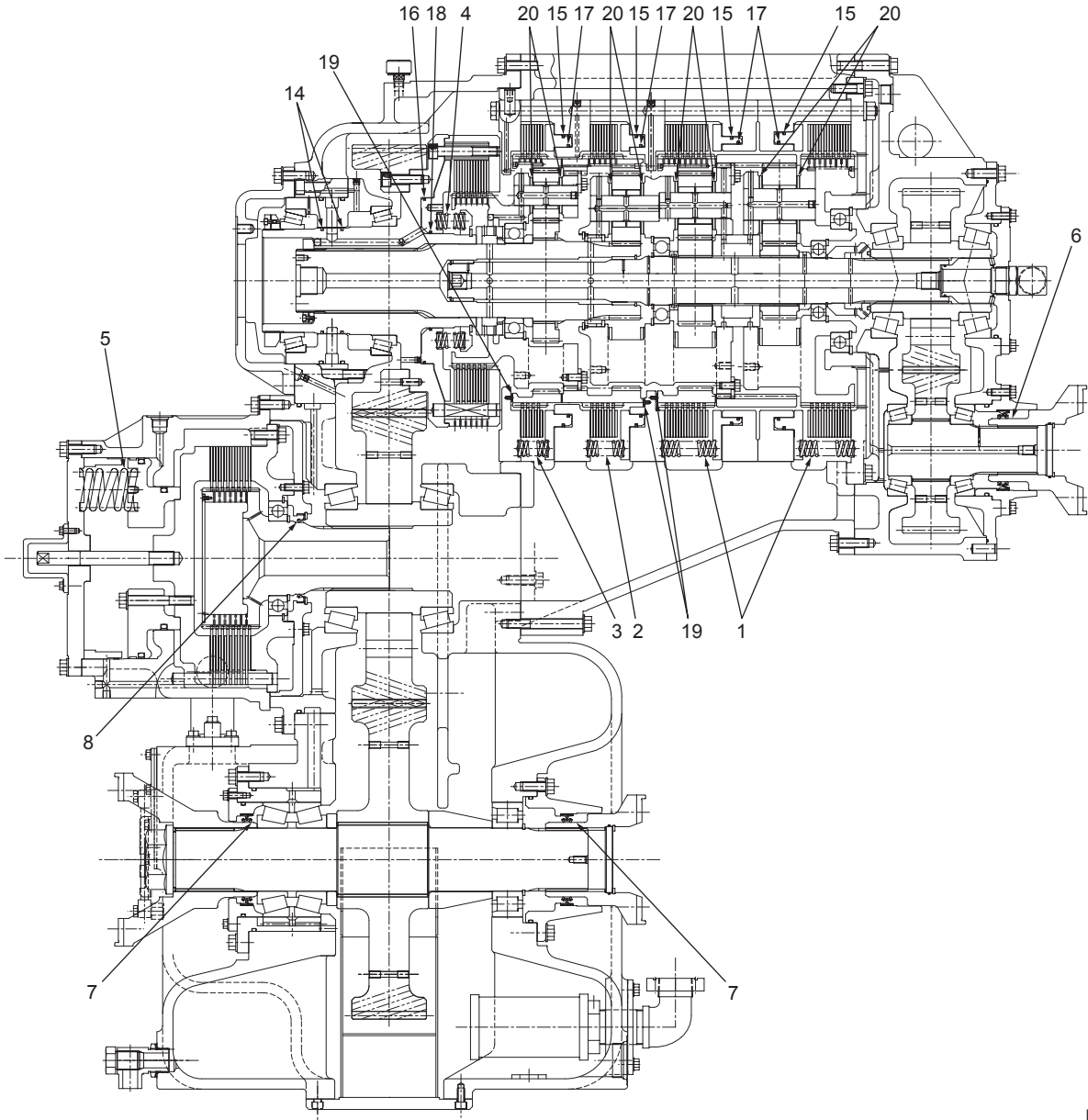

Hydraulic Parts Removal and Installation Warning

Disassembly and reassembly work of hydraulic parts greatly depends on the working area and working condition (soon after operation or not).

Understand the following items well and work safely.

WARNING

Unexpected movement of the machine could cause serious injury or death. To prevent such an accident, observe the following items:

- Park the machine on level and solid ground.
- Apply the parking brake and block the tires with chocks to prevent the wheels from moving.
- Be sure to remove the engine key, and hang a "DO NOT START!" tag on the operation board or the operator's seat.
- Relieve the internal pressure from the hydraulic line and the hydraulic tank.
- Use signals as agreed upon before starting work.
- Do not enter the hazardous area.
- When removing a heavy load over 20 kg (44 lbs), use a crane or a lift device.
- Stay out of the working area while using a crane.
- While working with the boom raised, put safety blocks or supports to prevent it from dropping suddenly.
- The temperature at each part may be high soon after the engine is stopped. Be careful not to get burned.
- When removing pipes, place a container to catch the drained oil.

IMPORTANT

- Cover the disconnected hoses and pipes with plastic caps or plugs to protect them from dust, water and dirt.
- Apply the specified torque to tighten each part.

44-22
 135ZV-2 Disassembly & Reassembly Hydraulic Group
 Hydraulic Pump

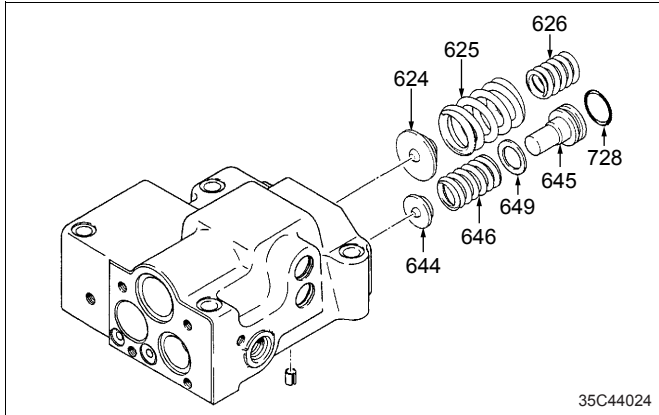

12. Insert spring seat (644), pilot spring (646) and adjusting ring (645) into the pilot hole. Insert spring seat (624), inner spring (626) and outer spring (625) into the compensation hole.

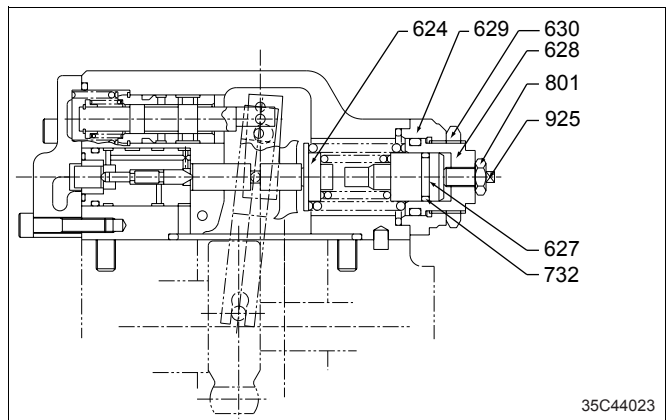
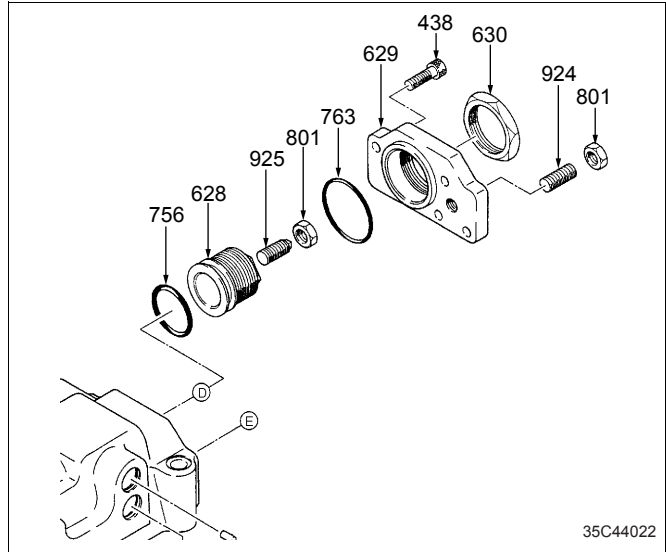

13. Insert adjusting screws (628)(925), adjusting ring (627), lock nut (630), hexagon nut (801) and adjusting screw (924) into cover (629). Then install cover (629).

44-32
 135ZV-2 Disassembly & Reassembly Hydraulic Group
 Pilot Valve (for Loading)

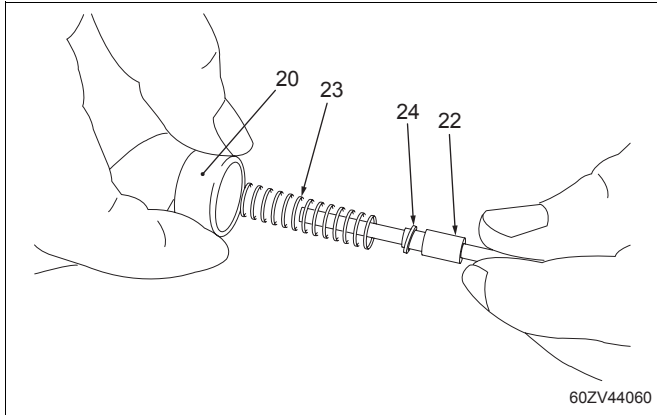

(b) Disconnect spool (22), spring seat (20), spring(23) and washer (24).

Note
 Only reducing valve in Port 4 has washer (24).

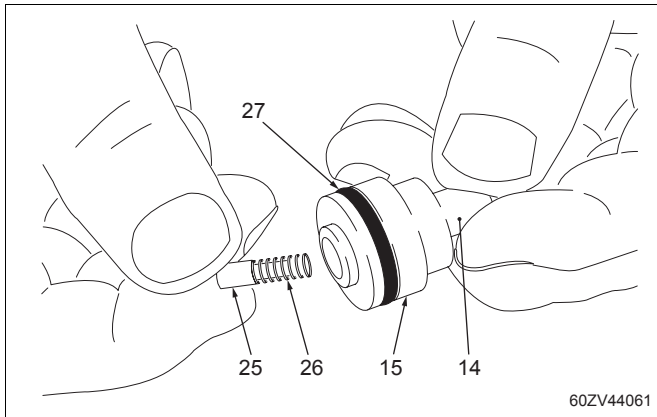

(c) Pull out spring seat (25) and spring (26) from push rod (14) and then pull out push rod (14) from plug (15).
 Remove O-ring (27) and the seal in the bore from plug (15).

Note
 Only Port 4 has spring seat (25) and spring (26).

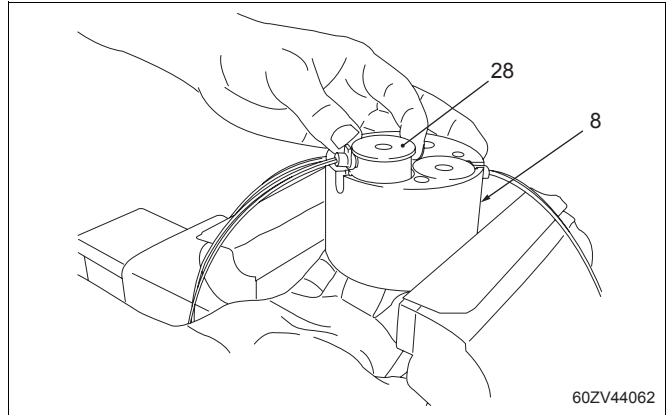

16. Remove solenoid sub (28) from detent casing (8).

Note
 When removing the solenoid sub, do not pull the electrical harness.

Pilot valve (for loading) assembling

To reassemble the pilot valve, follow the above disassembly procedure in reverse order.

Pilot valve (for loading) assembly cautions

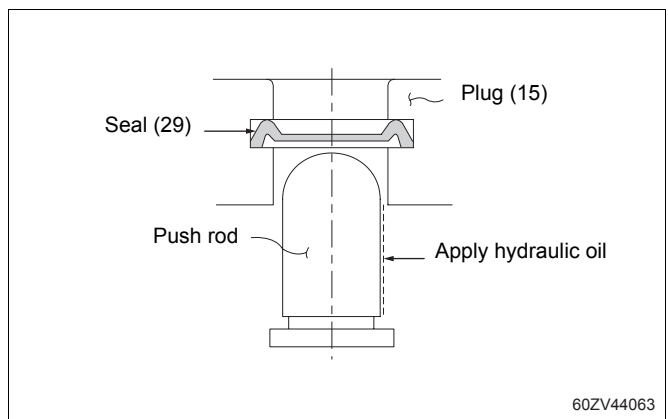

When reassembling seal (29) into plug (15), be careful about the direction of lip of seal (29).

Steering valve disassembling and assembling

IMPORTANT

Before disassembly or reassembly, read and understand the aforementioned "Hydraulic Parts Disassembly and Assembly Cautions" page 44-3.

Steering valve cross section and tightening torque

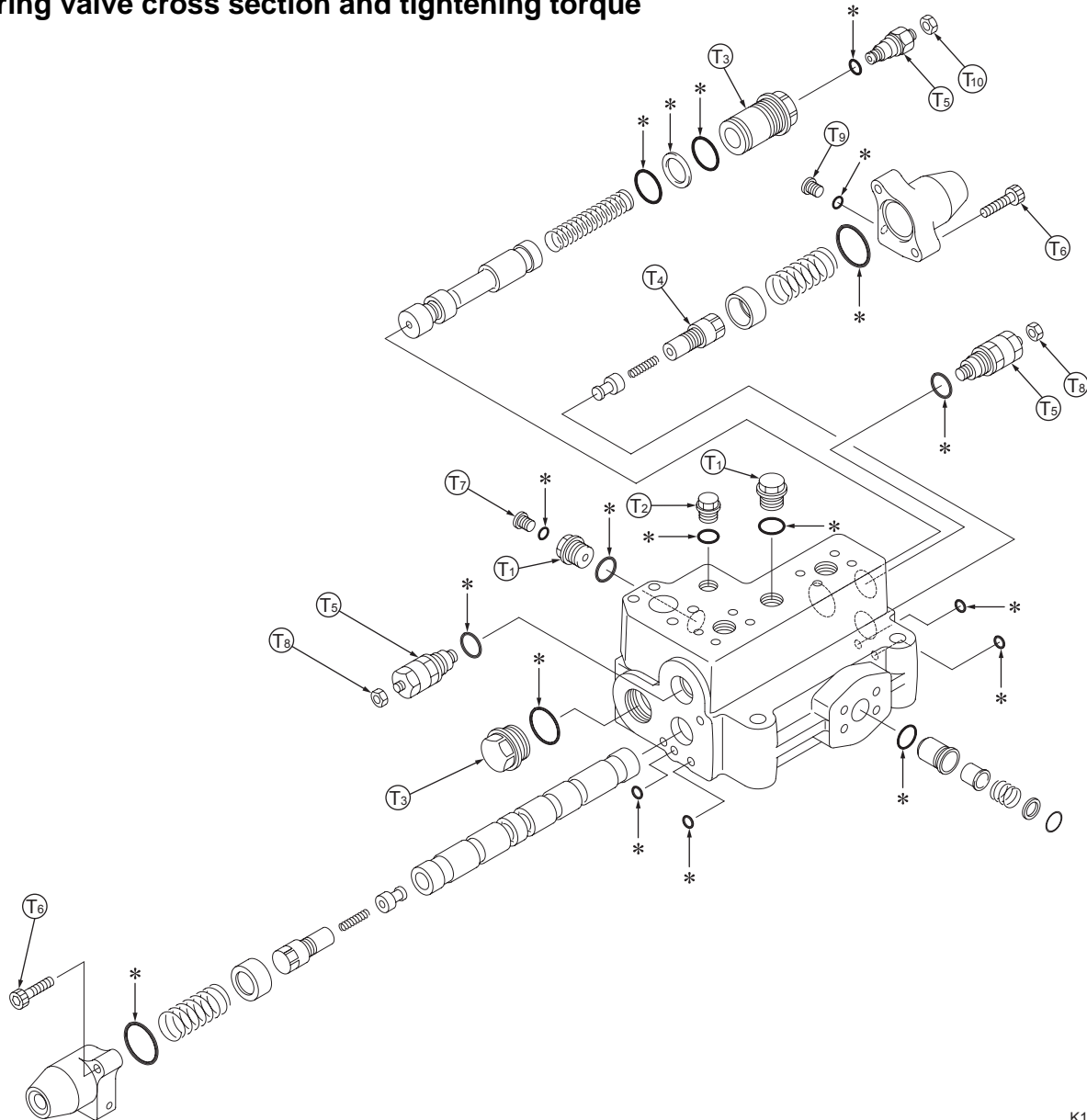

K135V2U44013



- T₁: 412 N-m (42 kgf-m) (304 lb-ft)
- T₂: 255 N-m (26.0 kgf-m) (188 lb-ft)
- T₃: 98 N-m (10 kgf-m) (72 lb-ft)
- T₄: 83 N-m (8.5 kgf-m) (61 lb-ft)
- T₅: 79 N-m (8.0 kgf-m) (58 lb-ft)

- T₆: 62 N-m (6.3 kgf-m) (46 lb-ft)
- T₇: 39 N-m (4 kgf-m) (29 lb-ft)
- T₈: 31 N-m (3.2 kgf-m) (23 lb-ft)
- T₉: 17 N-m (1.7 kgf-m) (12 lb-ft)
- T₁₀: 12 N-m (1.2 kgf-m) (8.7 lb-ft)

44-52
 135ZV-2 Disassembly & Reassembly Hydraulic Group
 Multiple Control Valve

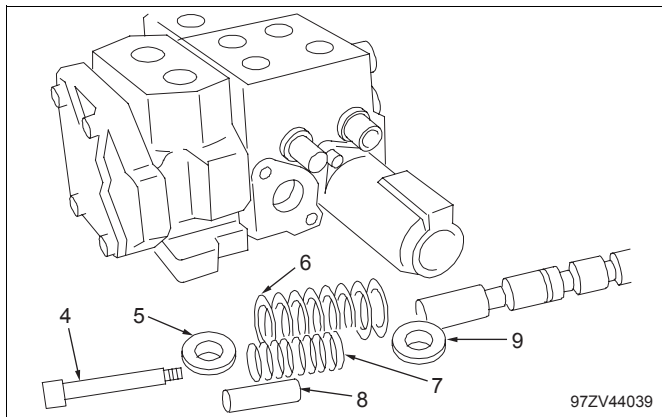

4. Remove bolt (4), spring retainer (5), outer spring (6), inner spring (7), stopper (8) and spring retainer (9).

[Boom spool disassembling]

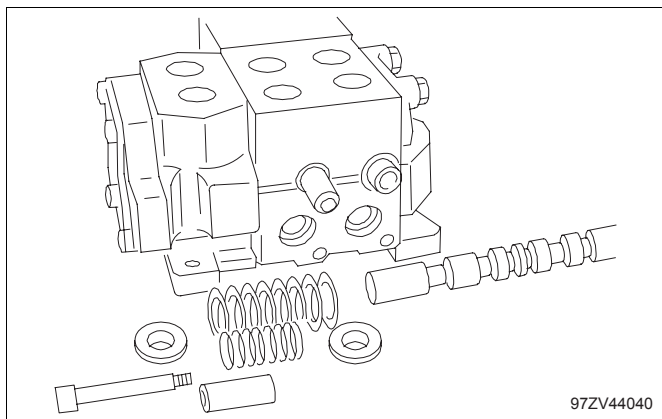

5. To disassemble the boom spool, refer to the bucket spool disassembling procedure.
 Be careful not to mix up the springs or spools.

[Relief valve disassembling]

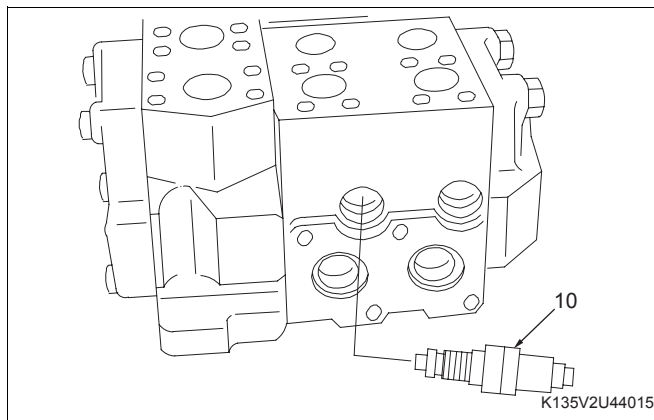

6. Remove overload relief valves (10).

 Valve (10): 79 N-m (8 kgf-m) (58 lb-ft)
 Hexagon width across flat: 34 mm (1.34 in)

Note

The overload relief valve should be replaced as an assembly. Therefore, do not disassemble it, unless absolutely necessary.

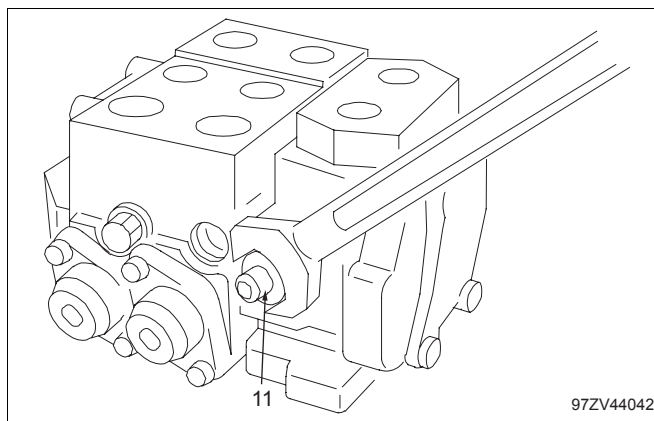

7. Remove main relief valve (11).

 Valve (11): 137 N-m (14 kgf-m) (101 lb-ft)
 Hexagon width across flat: 41 mm (1.61 in)

Note

The main relief valve should be replaced as an assembly. Therefore, do not disassemble it, unless absolutely necessary.

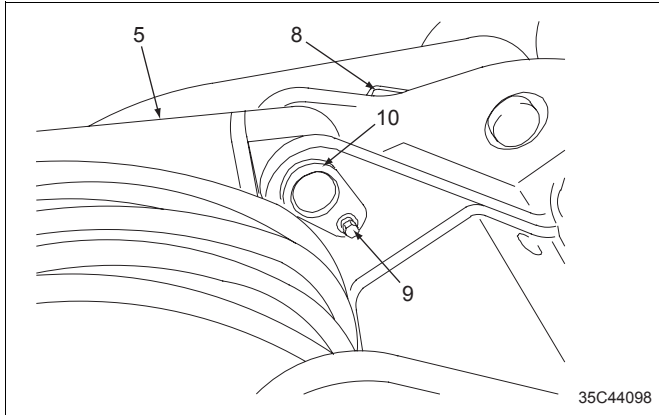

4. Remove grease pipe (8).
 Remove lock bolt (9), and then, remove pin (10).

Note
 Cover the disconnected pipe with plastic, cap or plug to protect it from dust, water and dirt.

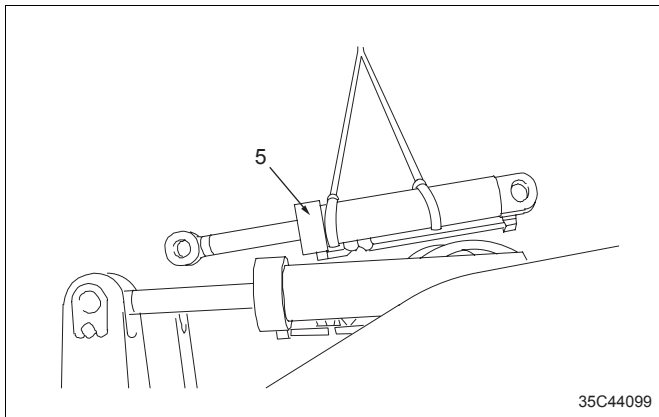

5. Sling bucket cylinder (5), and slowly lift it up to remove.
 Lower the cylinder onto the ground.

Bucket cylinder installing

To reinstall the bucket cylinder, follow the above removal procedure in reverse order.

Bucket cylinder installation cautions

⚠ WARNING

During service work, do not stand on the machine. Standing on tire, boom or linkage may cause accidents and serious injury or death. Use a stepladder, ladder, or work platform, and do not stand on the machine.

- Be sure the pins accept grease after installation.

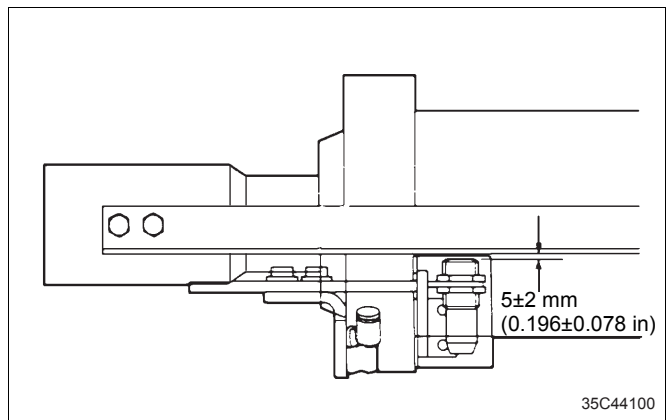

- Adjust the attachment leveler so that the clearance between the switch and the rod is 5±2 mm (0.196±0.078 in).
 Refer to "Attachment Leveler" page 15-8.

Cylinder air bleeding procedure

IMPORTANT

After repairing or replacing a cylinder, be sure to bleed the cylinder of air, or the piston seal or back-up ring may be seized.

- (a) While operating the engine at low-idling speed, operate the cylinder piston for 4 to 5 strokes.

Note
 Stop the piston about 100 mm (4.0 in) before fully stroking.

- (b) After that, stroke the cylinder piston fully to both ends 4 to 5 times.
- (c) Add hydraulic oil to the tank, and check the cylinder and its piping for oil leakage.

Hydraulic cylinder assembly cautions

Before starting work:

- Be sure to replace all the seals and packings.
- Clean and check all the parts. If a part is damaged, replace it.
- Before reassembling the parts, apply a coat of hydraulic oil to the parts.

CAUTION

Hot oil can cause injury or burns.
Use heat resistant gloves and extreme caution when heating and handling the components to avoid contact with hot oil.

Slipper ring installation

- Put the slipper ring into hot oil to heat the ring to 120~150°C (248~302°F).

Note

This is because the inner diameter of the slipper ring is smaller than the outer diameter of the piston. Therefore, heat the slipper ring to expand its inner diameter for easy attachment.

- Attach the slipper ring while taking care not to over expand it.
 - After attaching the slipper ring, cool the slipper ring so that it is contracted to the original size.
- Before installing the back-up ring and the O-ring, heat the back-up ring.

Note

This is because the inner diameter of the back-up ring is smaller than the outer diameter of the rod cover. To easily attach the back-up ring to the rod cover, heat the ring to soften it. The soft ring can be easily expanded.

Be careful not to over expand the back-up ring.

After installation, wait until the back-up ring is cooled, and then, insert the rod cover into the cylinder tube.

Brake valve disassembling and assembling

IMPORTANT

Before disassembly or reassembly, read and understand the aforementioned "Hydraulic Parts Disassembly and Assembly Cautions" page 44-3.

Brake valve cross section and tightening torque

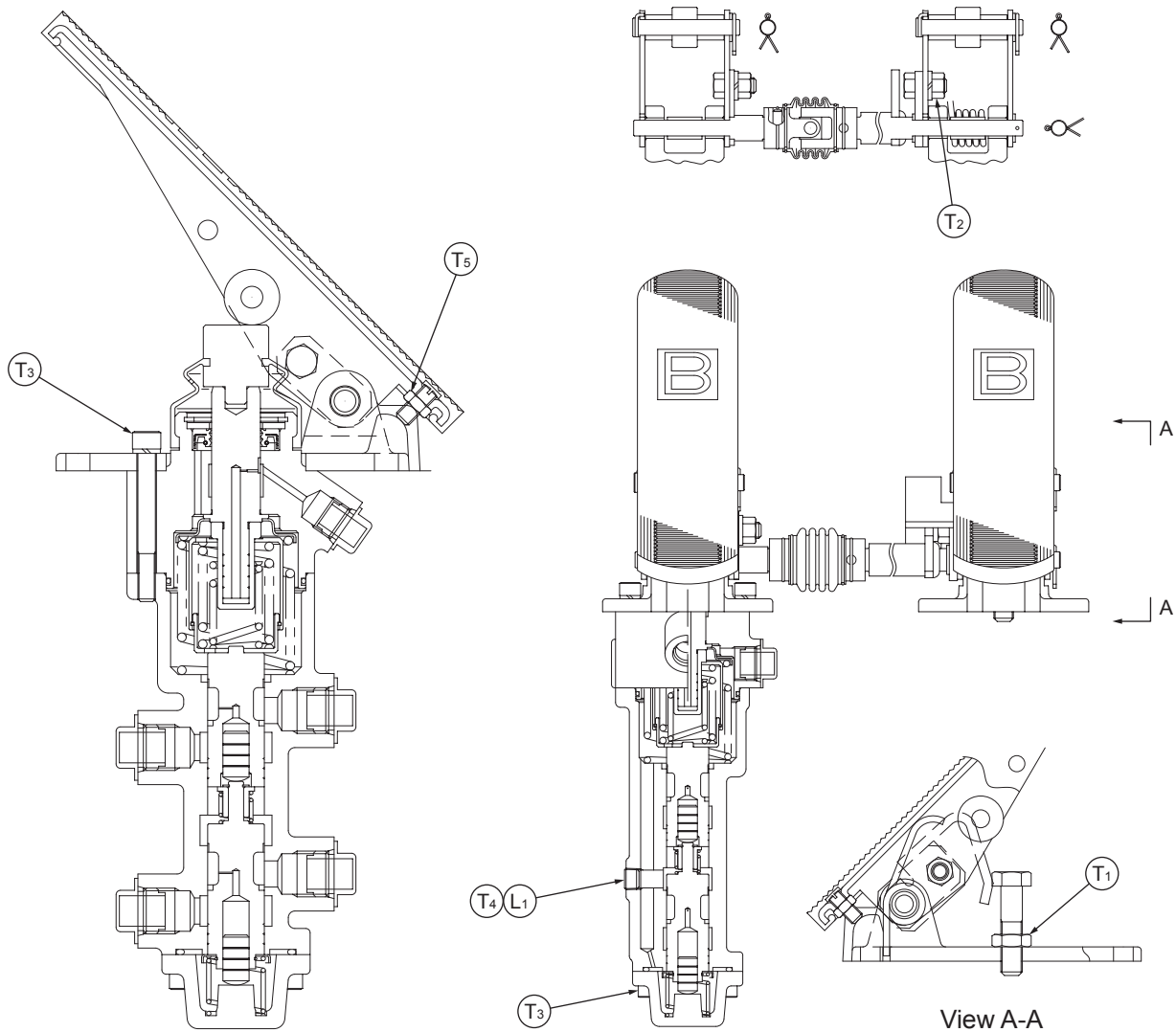

-  : T₁: 58.8 N-m (6.0 kgf-m) (43.4 lb-ft)
- : T₂: 34.3 N-m (3.5 kgf-m) (25.3 lb-ft)
- : T₃: 25.5 N-m (2.6 kgf-m) (18.8 lb-ft)
- : T₄: 11.8 N-m (1.2 kgf-m) (8.7 lb-ft)
- : T₅: 11.8 N-m (1.2 kgf-m) (8.7 lb-ft)

-  : L₁: Screw lock agent application (Loctite[®] 262)

Manifold Valve Assembly

Valve assembly removing and installing

Valve assembly removing

⚠ WARNING

Unexpected movement of the machine could cause an accident resulting in injury or death. To prevent such an accident, observe the following items:

- Park the machine on level ground.
- Block the front wheels with chocks to prevent the wheels from moving.
- Before starting work, be sure to remove the engine key, and hang a "DO NOT START!" tag on the operation board or the operator's seat, or disconnect the negative side of the battery.

IMPORTANT

If a battery terminal is removed from a machine in less than 30 seconds after the key is put into the "OFF" position, it can corrupt the ECM program, which can disable the engine. Always wait 1 full minute to be sure to be past this "write to memory function" prior to removing battery terminals.

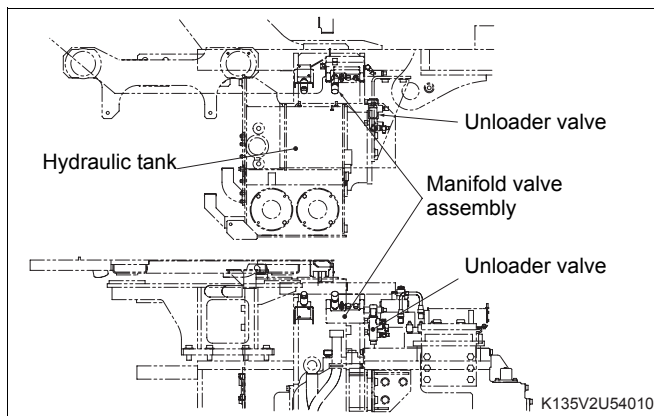

Before starting work:

- Stop the engine. Depress the brake pedal many times until there is no brake pressure.
- Press the hydraulic tank cap, and relieve the internal pressure from the hydraulic tank.
- Prepare a container to catch drained oil.

3. Piston guide

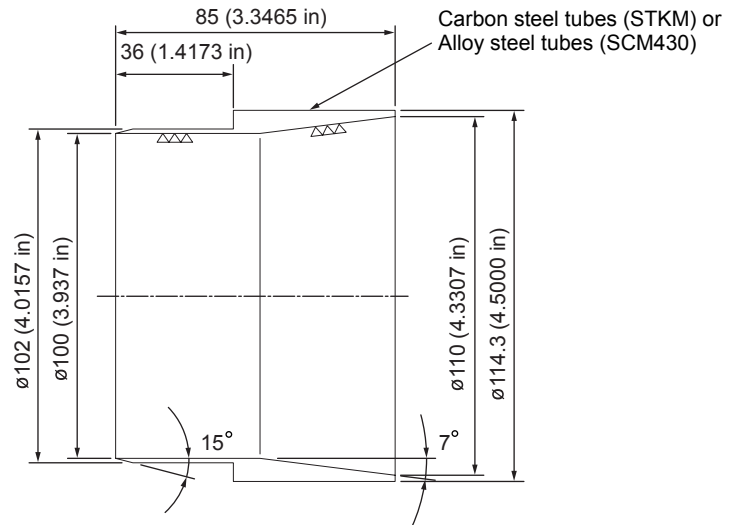

54-34
 135ZV-2 Disassembly & Reassembly Brake Group
 Parking Brake

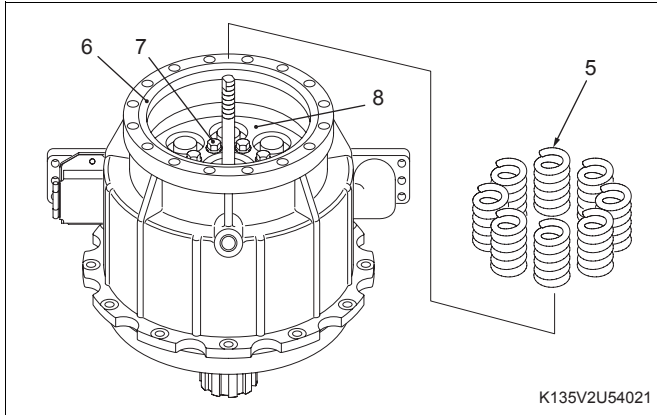

5. Remove eight springs (5) and ring (6).
6. Remove eight bolts (7) and remove piston (8).

: Bolt (7): 230 N-m (23.5 kgf-m) (170 lb-ft)
 : With lubricating oil (Engine oil or gear oil)
 : Piston (8): 24 kg (55 lbs)

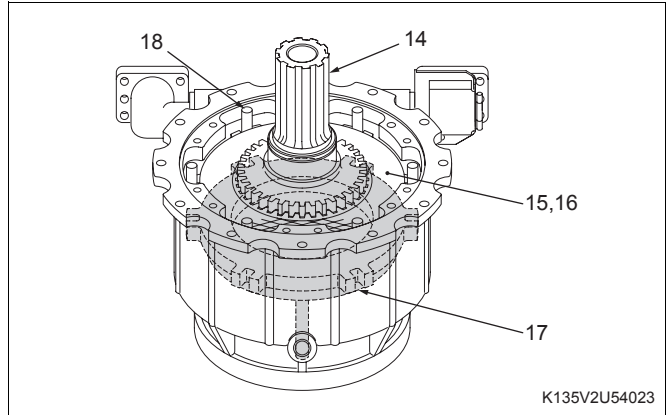

9. Remove shaft (14).

: Shaft: 27.5 kg (60 lbs)

10. Remove eight friction plates (15) and seven steel plates (16).

11. Remove piston (17).

: Piston (17): 37 kg (80 lbs)

12. Remove six pins (18).

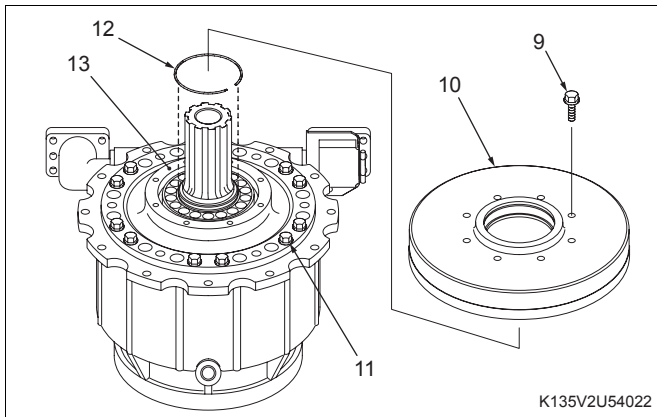

7. Turn over the parking brake assembly, and remove bolt (9). Remove seal retainer (10).

: Bolt (9): 93.7 N-m (9.55 kgf-m) (69 lb-ft)
 : With lubricating oil (Engine oil or gear oil)
 : Seal retainer: 27 kg (60 lbs)

8. Remove bolt (11) and snap ring (12).
 Remove bearing retainer (13).

: Bolt (11): 230 N-m (23.5 kgf-m) (170 lb-ft)
 : With lubricating oil (Engine oil or gear oil)
 : Bearing retainer: 28.5 kg (65 lbs)

Air Conditioner

Air conditioner removing and installing

Air conditioner removing

IMPORTANT

In case that it is necessary to replace the air conditioner parts, be sure to set the air conditioner mode as below before removing the air conditioner unit from the machine.

Temperature control: Max cool

Ventilation mode: Foot

Air intake control: Inside air circulation

Before starting work:

- Remove the seat in the cab.
- Collect the air conditioner refrigerant using the proper recovery method.
- Remove the floor mat in the cab.

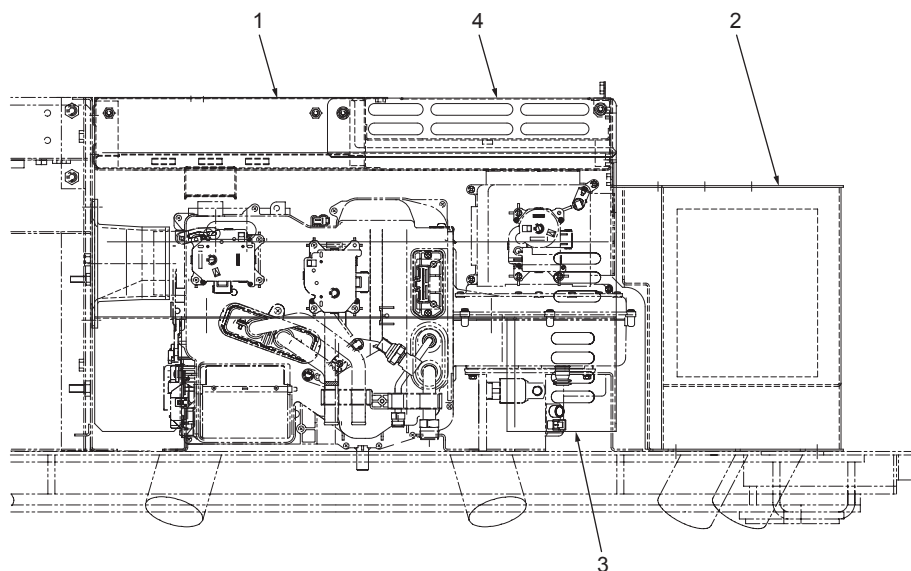

View from operator's seat

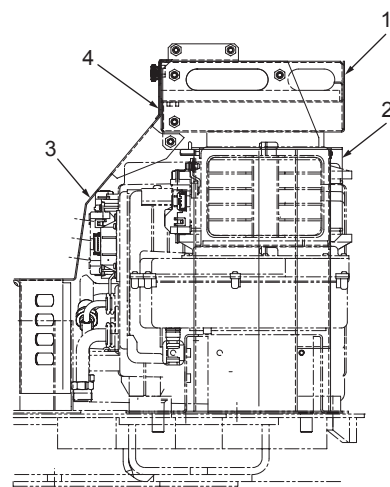

74-12
135ZV-2 Disassembly & Reassembly Operator Station Group

MEMO

CLICK HERE TO **DOWNLOAD** THE COMPLETE MANUAL

- Thank you very much for reading the preview of the manual.
- You can download the complete manual from: www.heydownloads.com by clicking the link below



- Please note: If there is no response to CLICKING the link, please download this PDF first and then click on it.

CLICK HERE TO **DOWNLOAD** THE COMPLETE MANUAL