

DB58, DB58S, DB58T DB58TI & DB58TIS DIESEL ENGINE

Shop Manual

65.99897-8079

Daewoo reserves the right to improve our products in a continuing process to provide the best possible product to the market place. These improvements can be implemented at any time with no obligation to change materials on previously sold products. It is recommended that consumers periodically contact their distributors for recent documentation on purchased equipment.

This documentation may include attachments and optional equipment that is not available in your machine's package. Please call your distributor for additional items that you may require.

Illustrations used throughout this manual are used only as a representation of the actual piece of equipment, and may vary from the actual item.

CLICK HERE TO **DOWNLOAD** THE COMPLETE MANUAL

- Thank you very much for reading the preview of the manual.
- You can download the complete manual from: www.heydownloads.com by clicking the link below



- Please note: If there is no response to CLICKING the link, please download this PDF first and then click on it.

CLICK HERE TO **DOWNLOAD** THE COMPLETE MANUAL

1. 3.3. Performance curve (DB58TI)

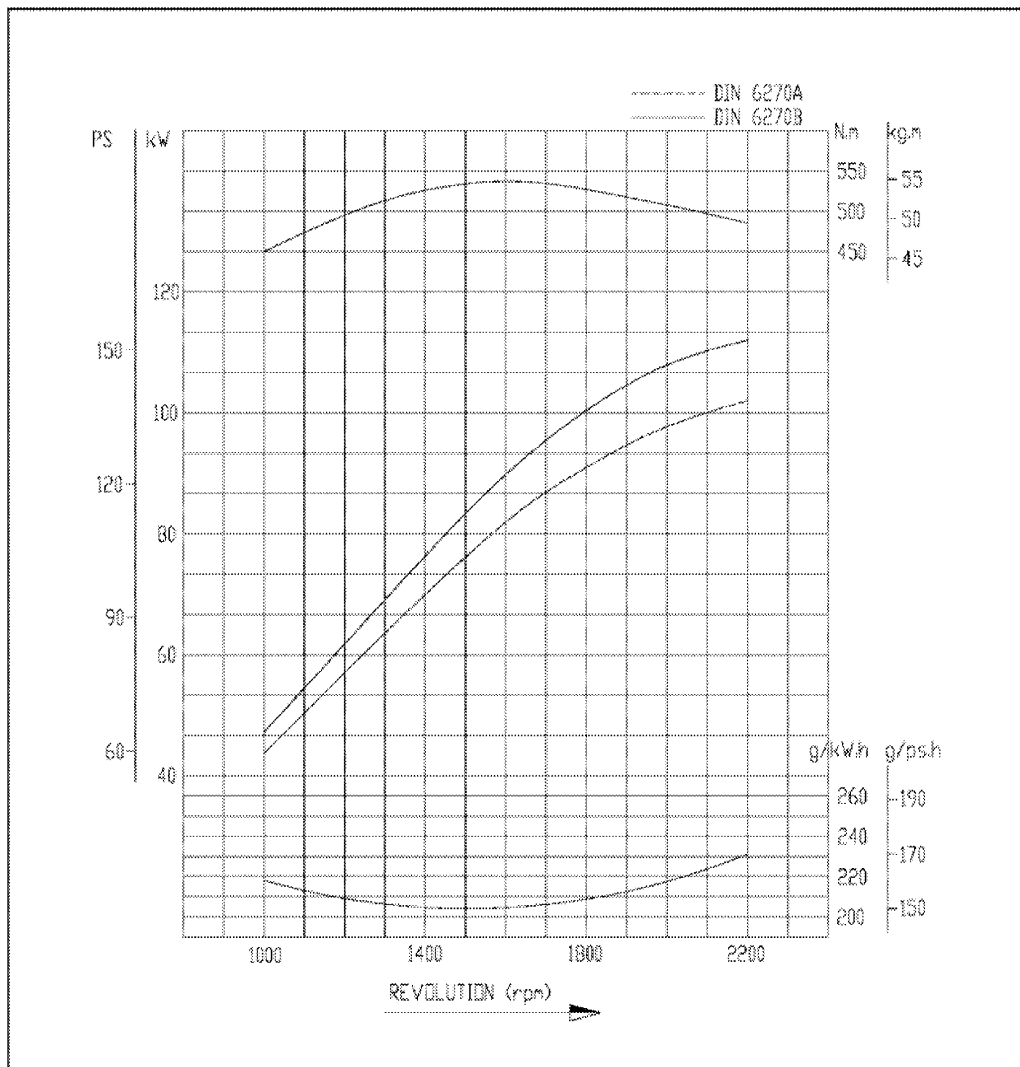

Performance	DIN 6270B	DIN 6270A
Output (rated)	112 kW (152PS) / 2,200 rpm	102 kW (138PS) / 2,200 rpm
Torque (min)	539 N.m (55.0 kg.m) / 1,600 rpm	
Fuel consumption (min)	204 g/kW.h (150 g / PS.h)	

- agent)
- Pay attention to cleanliness. The Diesel fuel must be free of water. See "Maintenance and care".
- Have the engine maintained at the specified intervals.
- Do not switch off the engine immediately when it is warm, but let it run without load for about 5 minutes so that temperature equalization can take place.
- Never put cold coolant into an overheated engine. See "Maintenance and care".
- Do not add so much engine oil that the oil level rises above the max. marking on the dipstick. Do not exceed the maximum permissible tilt of the engine. Serious damage to the engine may result if these instructions are not adhered to.
- Always ensure that the testing and monitoring equipment (for battery charge, oil pressure, and coolant temperature) function satisfactorily.
- Comply with instructions for operation of the alternator. See "Commissioning and operation".
- Do not let the water pump run dry. If there is a risk of frost, drain the water when the engine switched off.

1.5.4. Regulations designed to prevent pollution

a) Engine oil, filter element, fuel filter

- Take old oil only to an oil collection point. Take strict precautions to ensure that oil does not get into the drains or into the ground.
- The drinking water supply may be contaminated.
- Oil and fuel filter elements are classed as dangerous waste and must be treated as such.

b) Coolant

- Treat undiluted anti-corrosion agent and / or antifreeze as dangerous waste.
- When disposing of spent coolant comply with the regulations of the relevant local authorities.

1.5.5. Notes on safety in handling used engine oil

Prolonged or repeated contact between the skin and any kind of engine oil decreases the skin.

Drying, irritation or inflammation of the skin may therefore occur. Used engine oil also contains dangerous substances which have caused skin cancer in animal experiments. If the basic rules of hygiene and health and safety at work are observed, health risks are not to the expected as a result of handling used engine oil.



<Health precautions>

- Avoid prolonged or repeated skin contact with used engine oil.
- Protect your skin by means of suitable agents (creams etc.) or wear protective gloves.
- Clean skin which has been in contact with engine oil.
 - Wash thoroughly with soap and water, A nailbrush is an effective aid.

2.8. Cooling system

The engine has a liquid-cooling system. The fresh water pump is a maintenance-free by V-belt from the crankshaft pulley.

Depending on the agreed extent of delivery and the design of the engine, the coolant circuit can be equipped with temperature monitors which, in the event of loss of coolant, shut the engine down.

- Check the coolant level of the expansion tank by removing the expansion tank filler cap, and add coolant if necessary.
- When injecting antifreeze solution, first drain out the old coolant from the cylinder block and radiator, and then clean them with cleaning solution.
- Be sure to mix soft water with antifreeze solution.

2.8.1 Cooling system (Type -1)

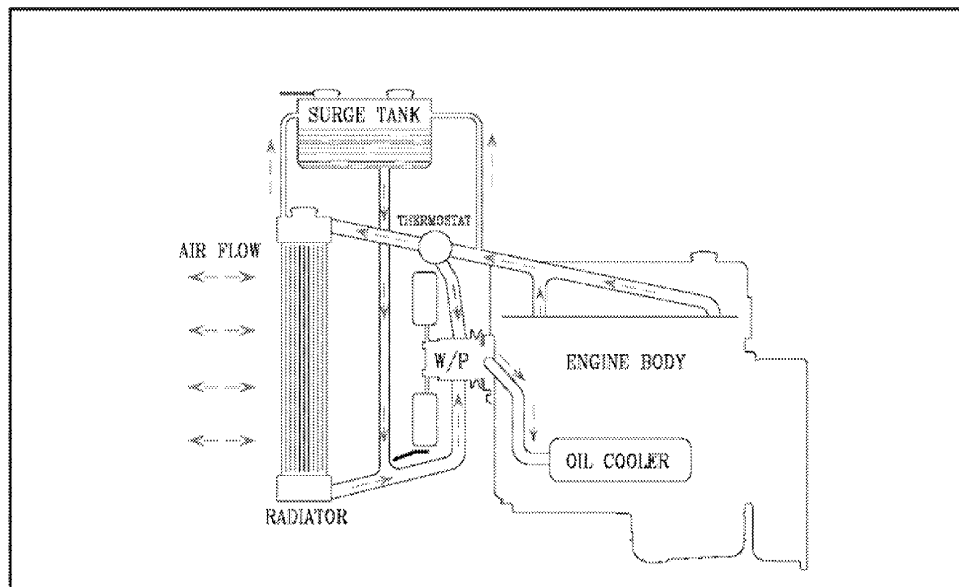

2.8.2 Cooling system (Type -2)

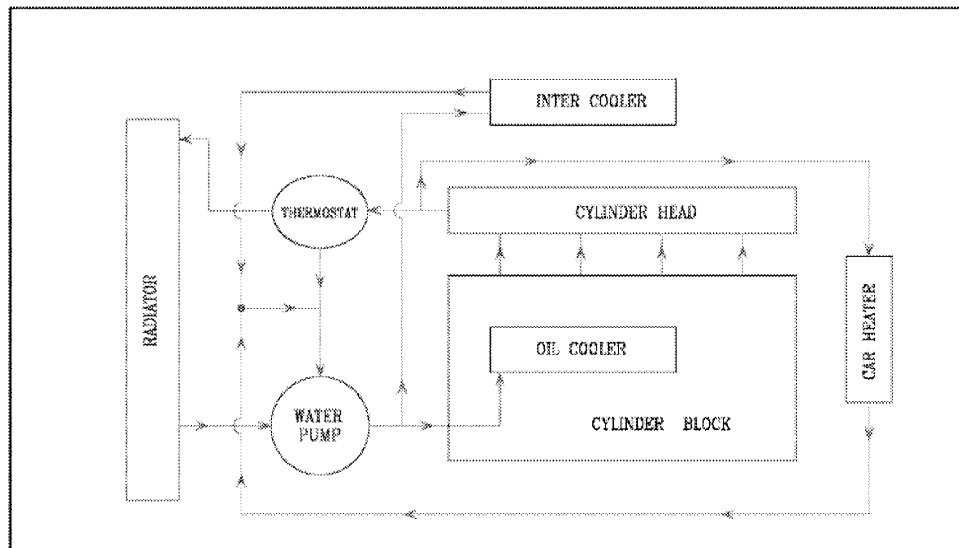

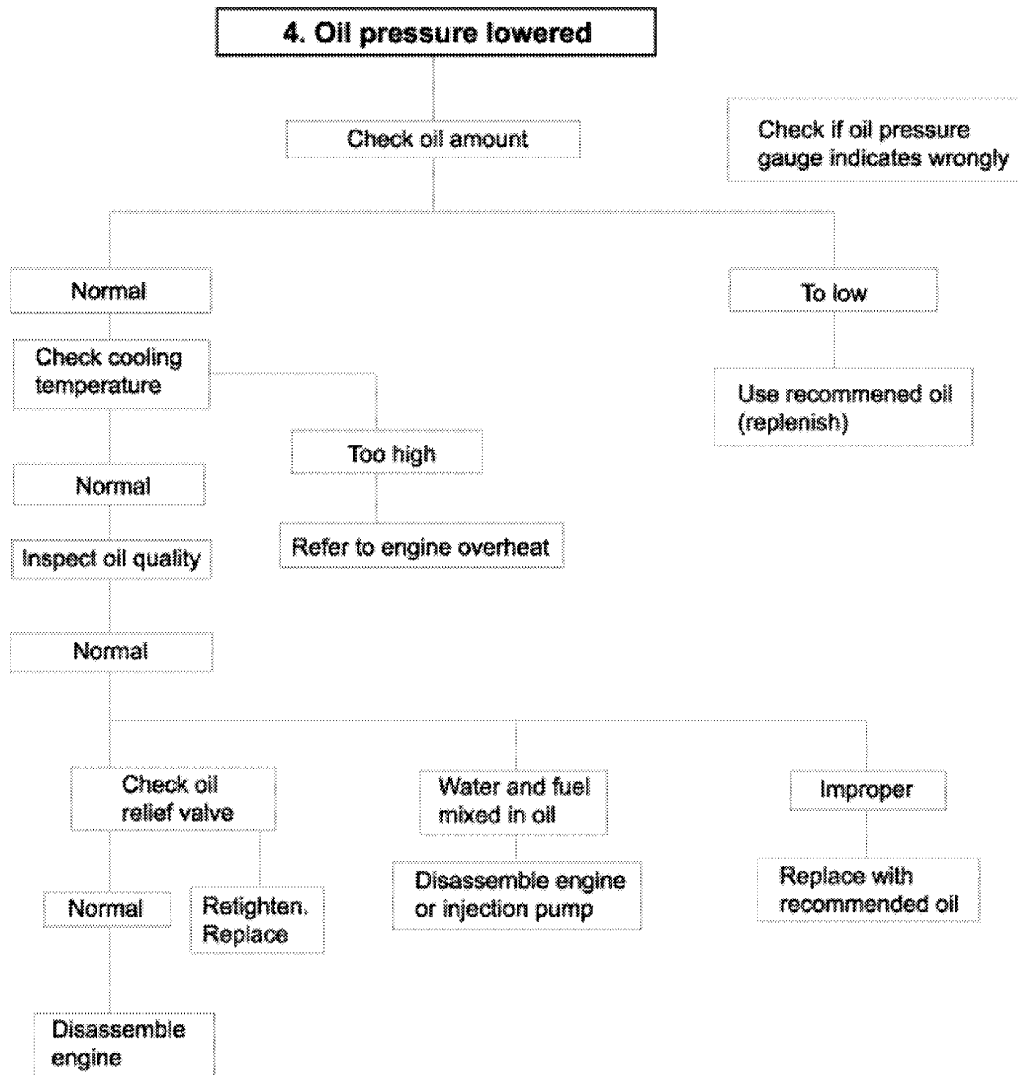

4) Camshaft and rocker arm



(Unit : kg.m)

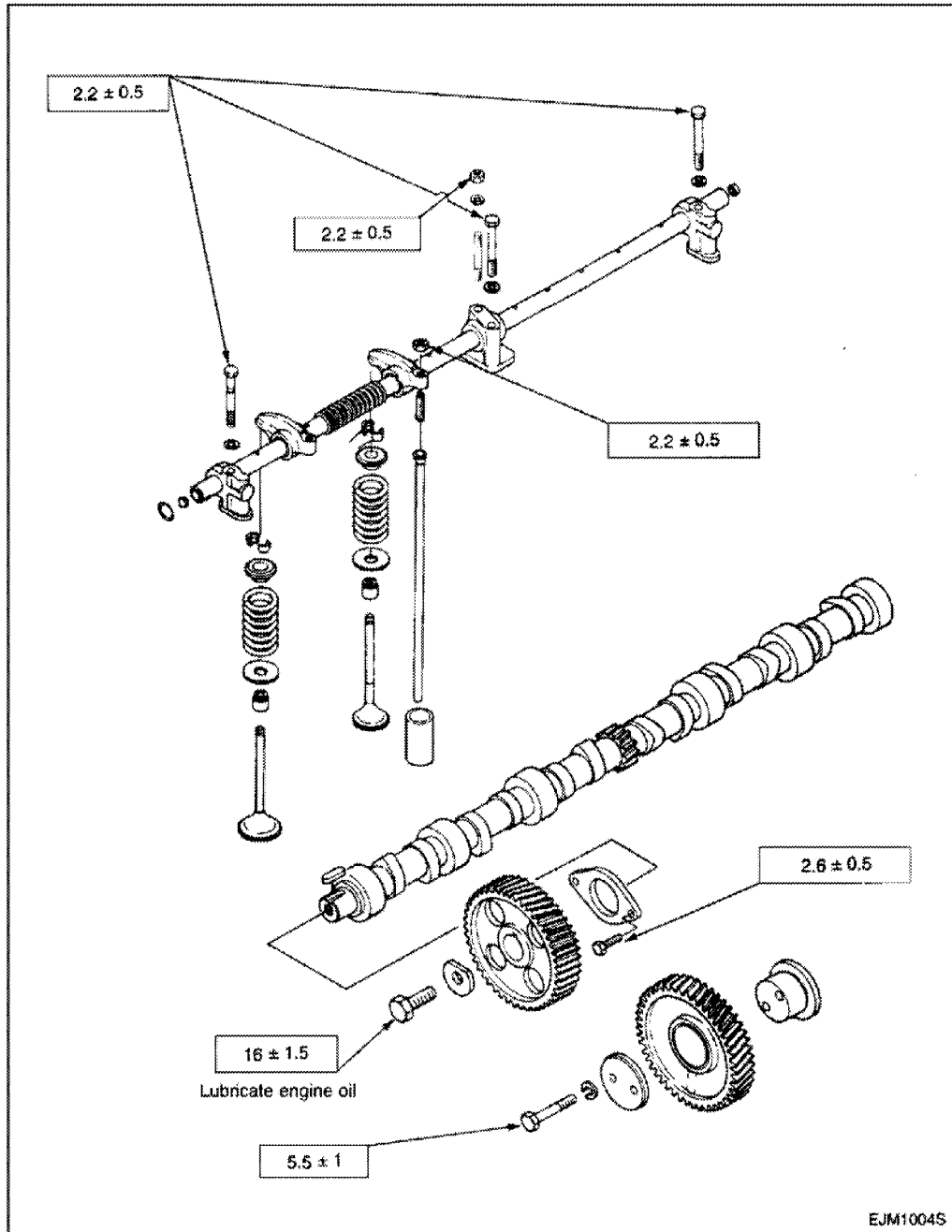

3.1.2. Main structure parts (1)

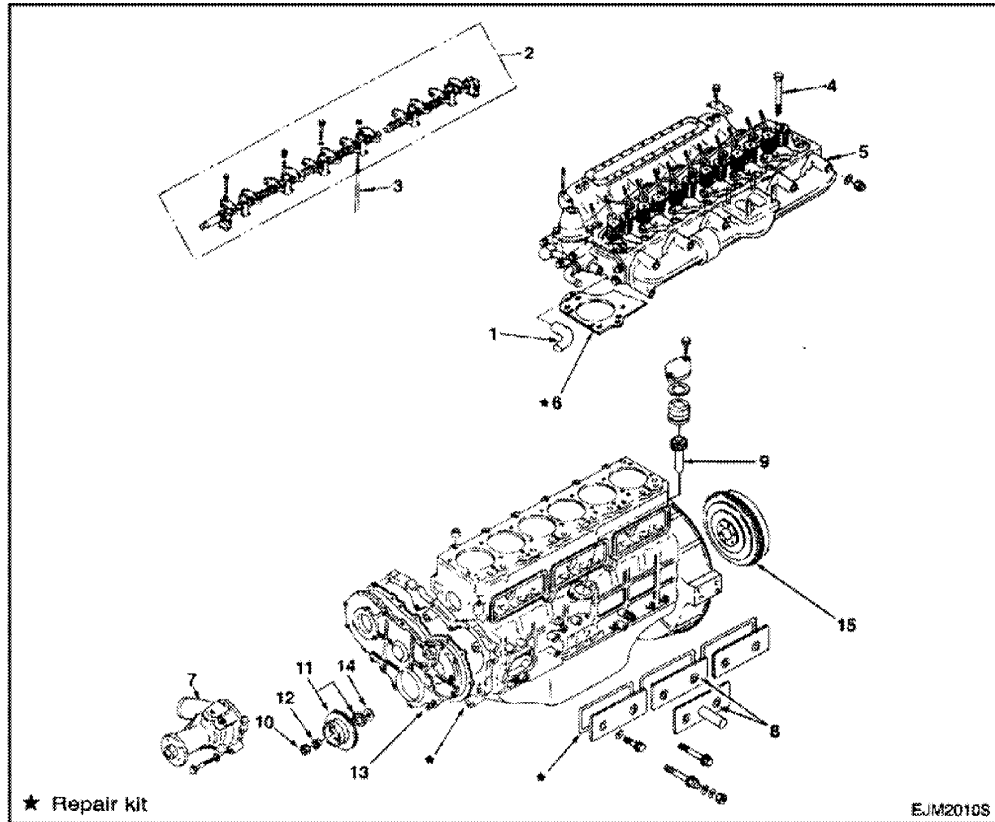

- | | |
|----------------------------------|---------------------------------------|
| 1. Rubber hose (Coolant by-pass) | 9. Oil pump driving pinion |
| ▲2. Rocker arm shaft assembly | 10. Nut |
| 3. Push rod | ▲11. Crankshaft pulley and dust cover |
| 4. Cylinder head bolt | ▲12. Taper bushing |
| ▲5. Cylinder head assembly | 13. Timing gear cover |
| 6. Cylinder head gasket | 14. Oil thrower |
| 7. Coolant pump assembly | ▲15. Fly wheel |
| 8. Tappet chamber cover | |



2) Rocker arm shaft



Loosen the rocker arm shaft fixing bolts a little in numerical sequence as specified.

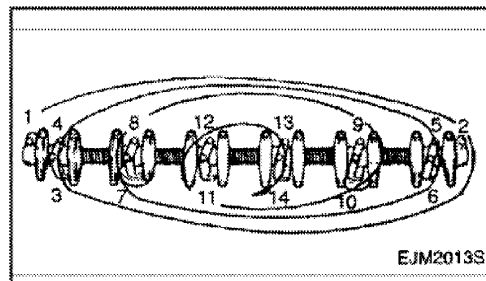

2) Measuring method – II



- Measure valve stem outside diameter.
- Measure valve guide inside diameter by using of caliper calibrator or telescoping gauge.
- The difference between the valve stem outside diameter and the valve guide inside diameter is the valve stem clearance.

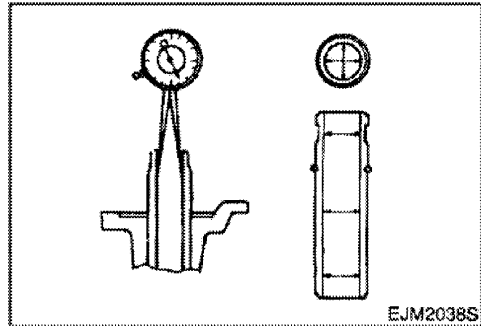

3) Valve guide replacement



- Removal of valve guide
- Pull out the valve guide, by using hammer and valve guide remover, from bottom of cylinder head.

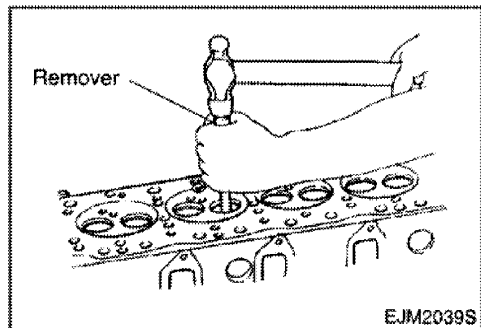

- Install of valve guide
- The height from the bottom of the cylinder head to the edge of valve guide top should be 14.1mm.

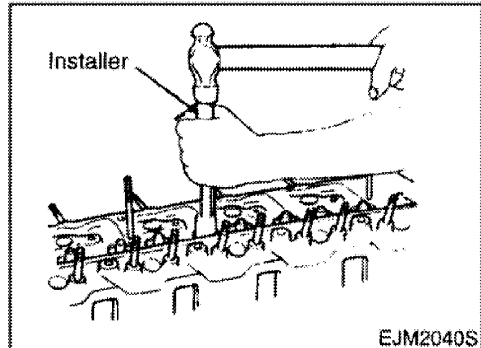

4) Valve depression



- Install the valve ① to the cylinder head ②.
- Measure valve depression by using the depth gauge or calibrator from the bottom of cylinder head.
- Seat insert and valve must be replaced if the measured value exceed the specified limit.
- If the valve is replaced, the valve guide must be also replaced.

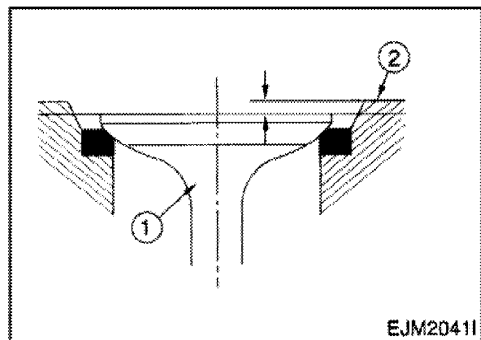

Grade marking	Cylinder block bore diameter
1	∅105.090 ~ ∅106.000 mm
2	∅106.000 ~ ∅106.010 mm

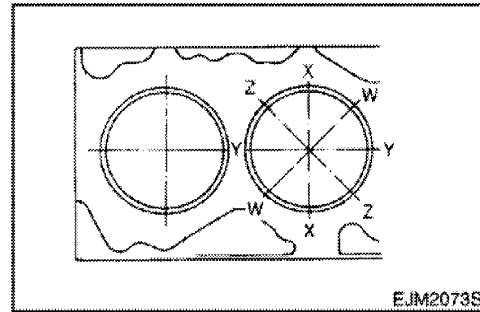

3) Cylinder liner outside diameter

- Measure the liner outside diameter at ①, ② and ③ measuring point across X-X, Y-Y.

Measuring Points :

- ① 20.0 mm
- ② 105.0 mm
- ③ 185.0 mm

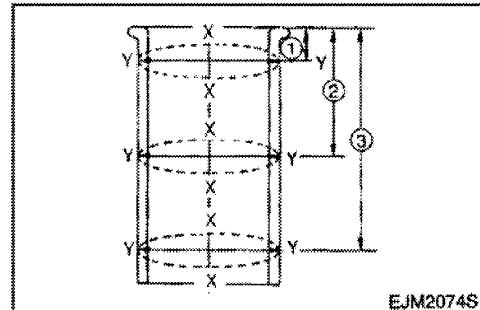

- Calculate the average value of 6 measurements to determine the correct cylinder liner grade.
- Combination of the cylinder bore and the cylinder liner outside diameter.

	Steel liner (tightness)	Cast iron liner (clearance)
Cylinder liner fitting clearance	0.001 ~ 0.019mm	0.005 ~ 0.026mm

<Cylinder bore and liner outside diameter>

(A) Steel cylinder liner

Grade	Cylinder bore	Cylinder liner outside diameter
1	∅105.001 ~ ∅105.010mm	∅105.011 ~ ∅105.020mm
2	∅105.011 ~ ∅105.020mm	∅105.021 ~ ∅105.030mm
3	∅105.021 ~ ∅105.030mm	∅105.031 ~ ∅105.040mm

(B) Cast iron cylinder liner

	Cylinder liner diameter		Grade marking
	⊙ position	①, ⊙ position	
∅D (Inner diameter)	∅102.020 ~ ∅102.031mm	∅102.017 ~ ∅102.035mm	1
	∅102.031 ~ ∅102.042mm	∅102.028 ~ ∅102.046mm	2
∅E (Outer diameter)	∅105.973 ~ ∅105.984mm	∅105.970 ~ ∅105.988mm	A
	∅105.984 ~ ∅105.995mm	∅105.981 ~ ∅105.999mm	B

the specified limit.

	Standard	Limit
Crankshaft run-out	0.05 mm	0.40 mm

- If the repaired crankshaft generated a crack, replace it.

6) Main bearing and con-rod bearing tension



- Check to see if the bearing has enough tension, and set bearing into its regular position with the finger pressure.

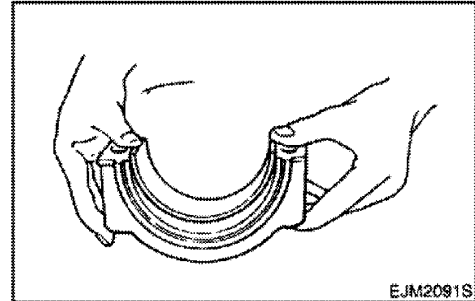

EJM2091S

7) Crankshaft regrinding

- Pay close attention to the following steps in order to ensure the reground-crankshaft reliability.

Undersize bearing Availability	0.25 mm	0.50 mm
--------------------------------	---------	---------

<Crankshaft regrinding procedure>



- (1) Grind the crankshaft journal part and pin part.
- (2) Fillet the crankshaft journal and crank pin radius to a minimum of $R3.5 \pm 0.2$.
There must be no stepping around the fillet area.
- (3) Finish the crankshaft journal, crank pin and oil hole corners to a smooth surface having a chamfer radius of 1mm.

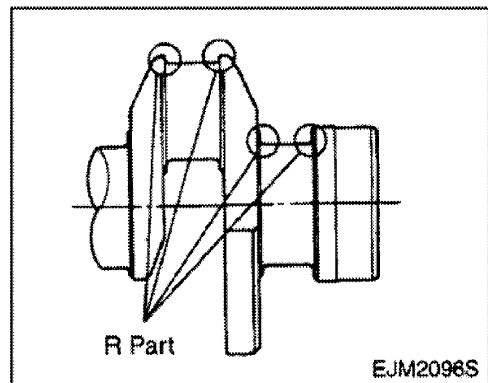

EJM2096S

Crankshaft Journal and crank pin roughness	0.4μ or less
--	--------------

- (4) Measure the clearance between crankshaft journal and crank pin.
- (5) Measure the crankshaft run-out.

CLICK HERE TO **DOWNLOAD** THE COMPLETE MANUAL

- Thank you very much for reading the preview of the manual.
- You can download the complete manual from: www.heydownloads.com by clicking the link below



- Please note: If there is no response to CLICKING the link, please download this PDF first and then click on it.

CLICK HERE TO **DOWNLOAD** THE COMPLETE MANUAL

2) Crankshaft bearing (lower)



- There is no oil hole and oil groove on the lower bearing. But opposite upper bearing has oil hole and oil groove.

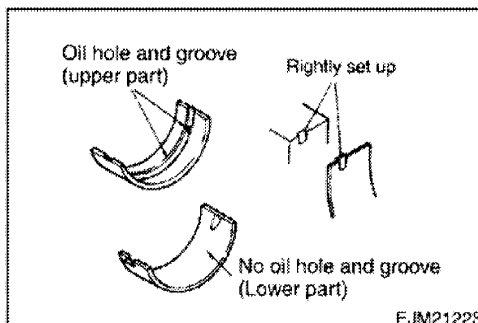

3) Crankshaft

- Assemble the crankshaft gear in front side.



- CAUTION:**
Make sure the part number of crankshaft because its counterweight size may be different depending upon engines.

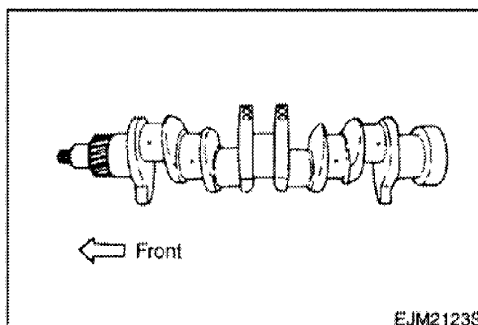

4) Thrust washer



- Assemble thrust washer with the oil groove side facing the crankshaft sliding face.

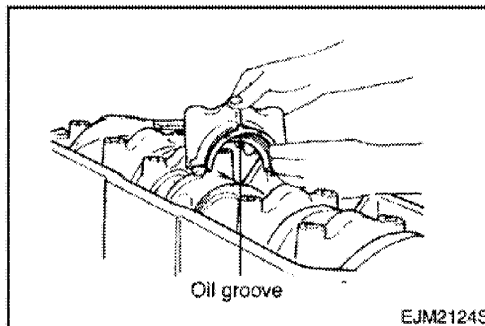

5) Crankshaft bearing cap



- Lubricate the bearing cap bolts with engine oil.
- Assemble the bearing caps to the crankshaft.



The arrow mark must be pointing to the front of the engine.

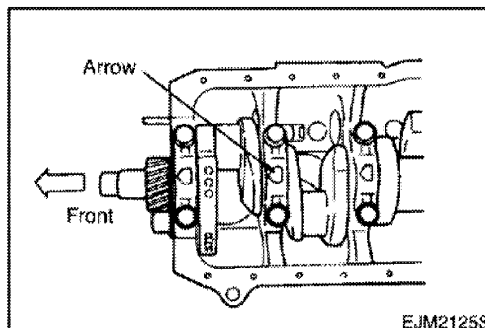

1) Cylinder head cover



- Tighten the cylinder head cover bolts to the specified torque a little at a time in the sequence. (see figure)

Cylinder head cover bolt torque	2.2 kg m
---------------------------------	----------

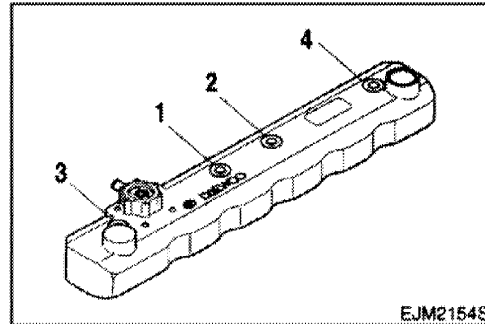

Fan belt



- Adjust the fan belt tension.

2) Starter



- Tighten the starter bolts to the specified torque after install the starter to the flywheel housing.

Starter fixing nuts torque	2.2 kg m
----------------------------	----------

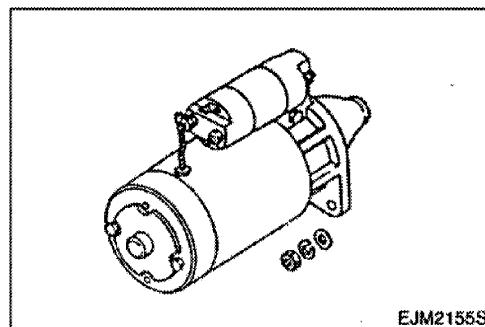

3) Injection nozzle



- Install the injection nozzle with the injection nozzle gaskets.

Injection nozzle nuts torque	2.2 kg.m
------------------------------	----------



- Be careful not to damage the nozzle tips.

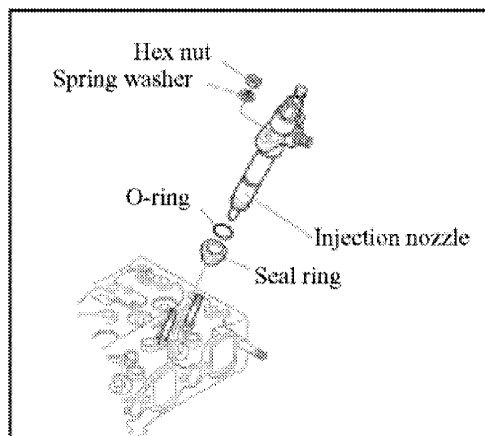

4) Fuel injection pipe



- Install the fuel injection pipes ① and tighten the bolts to the specified torque.

Injection pipe torque	3.0 kg.m
-----------------------	----------

- Carefully position and set the

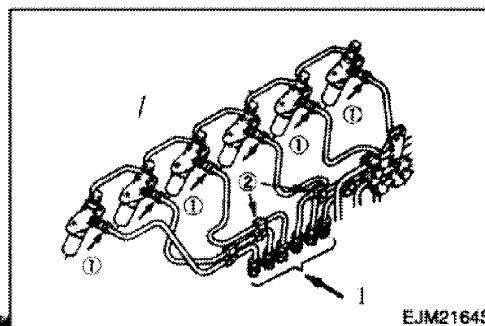

4. Commissioning and Operation

4.1. Preparation

At the time of initial commissioning of a new or overhauled engine make sure to have observed the "Technical Information for the installation DAEWOO generator engines".

- Oil filler neck on cylinder head cover
Before daily starting of the engine, check the fuel, coolant and oil level, replenish if necessary.
The notches in the dipstick indicate the highest and lowest permissible oil levels.
The oil required in the sump is specified in the "Engine Specification".



NOTE

The oil required to fill the oil fillers and pipes depends upon the engine and use and must be determined individually at the time of initial commissioning. (Make the Max and Min. marks of the determined quantity on the oil level gauge.)

- Cleanliness
Ensure utmost cleanliness when handling fuels, lubricants and coolants

4.1.1. Starting

For engine starting, please confer the instruction.



NOTE:

1. *Preheating devices are attached to the engine for improving the starting abilities at extremely low temperature.*
2. *Do not actuate the starter for longer than 10 seconds. If starting fails regardless of the preheating, start the preheating again after 30 seconds.*

a) Pre-heating system

Operation 1: Turn the key switch to the HEAT position, then the pilot lamp lights up for about 20 seconds. When the pilot lamp is extinguished, do operation 2.

Behavior - When the coolant temperature is below 10 °C in cold weather, you'd better operate the pre-heating system (Glow plug)

- If the pre-heating is not necessary, the pre-heating system is not operated with the pilot lamp.

Operation 2: After checking the pilot lamp, turn the key switch to the START position to crank the engine, at once.

Behavior - When the key switch is placed in the START position, glow plug is continuously heated to facilitate starting operation

- If the coolant temperature is above 10 °C, glow plug needs not be heated.

Operation 3: After the engine is cranked, convert the key switch to the ON position.

4.8. Injection timing



CAUTION:

Take care to avoid entry of dust or foreign particles into the pump interior when the timing adjustment is made.

<Check procedure>



- Align the crankshaft pulley TDC mark with the pointer.
- Remove the inspection hole cover at the front of the injection pump on the timing gear case cover.

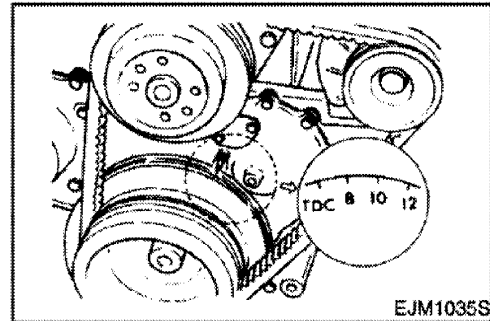

- Check the alignment between the pointer④ on the injection pump gear nut lock plate and the projection area mark③ on the injection pump gear case.
- If it is in misalignment, recheck with turning the crankshaft pulley one more turn to repeat the foregoing procedure to mark sure that it is in alignment.
- Check the alignment of the notched lines① and ②. (These notched lines were aligned at the factory to set the injection pump body and the mounting flange.)
Next, inspect the crank angle position of the injection timing.

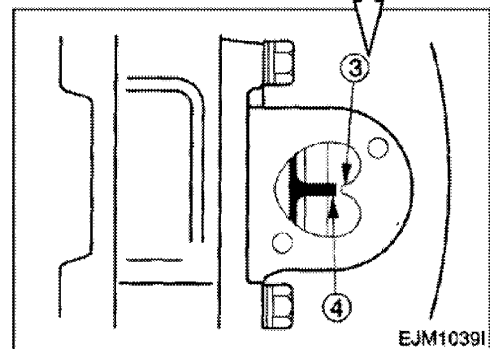
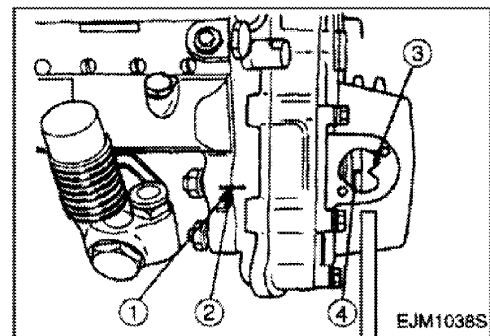

<Check procedure>

- Turn the crankshaft pulley counterclockwise about 30° crank angle.

5.1.2. Oil cooler

 1) Disassembly

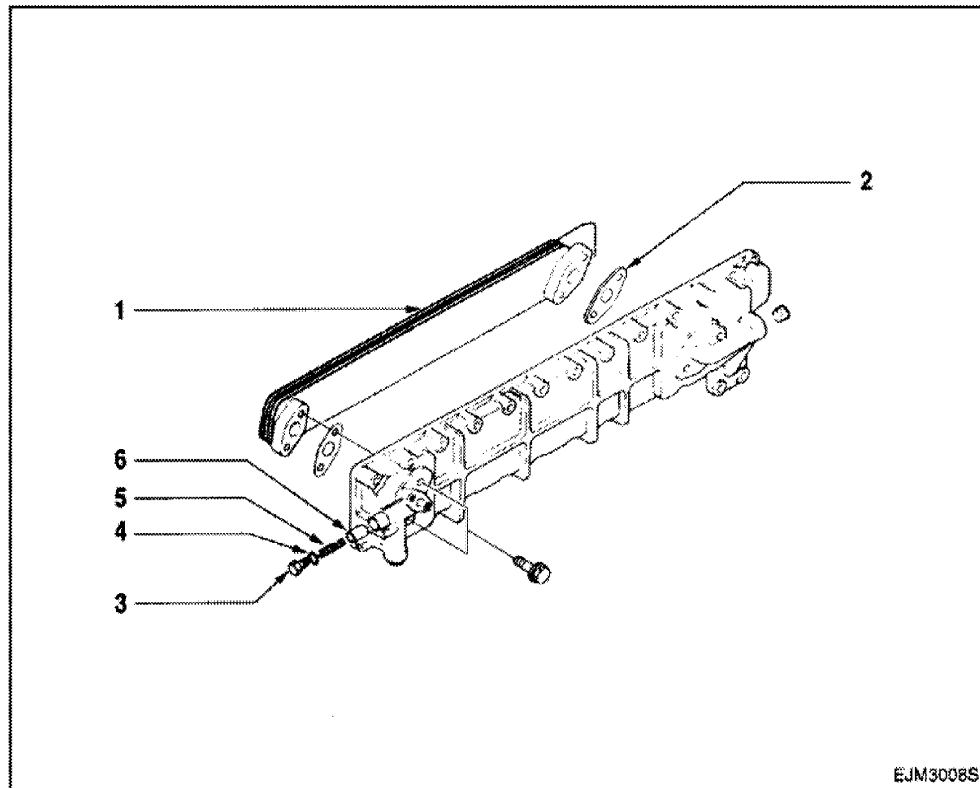

- | | |
|-----------------------|-------------------------|
| 1. Oil cooler element | 4. O-ring |
| 2. Gasket | 5. By-pass valve spring |
| 3. By-pass plug | 6. By-pass valve |

 2) Inspection

- Correct or replace the part if the wear or damage is discovered during inspection.

 3) Oil cooler element

- Install the oil cooler element to the oil cooler, then tighten the oil cooler element fixing bolts to the specified torque.

Oil cooler element fixing bolts torque	2.2 kg.m
---	----------

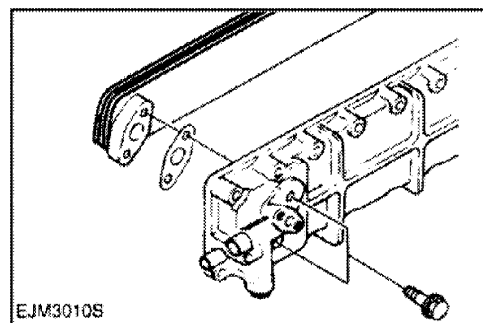

 4) Oil cooler reassembly

- To assemble, follow the disassembly procedures in reverse order.

5.3.3. Parts no of injection system

1) Injection pump assembly

Engine model	Part no.	Suffix
DB58	65.11101-7380	EARDA/EAREA/B/EARFA/B/C/D/E/F/H/I/J EARLA/B/C
DB58S	65.11101-7399	ECRFA/B/C/ECRLA
DB58T	65.11101-7655	EATEA/B/C/D/EATLA
	65.11101-7375	EATEE/F/G/H/I/J/EATLB
DB58TI	65.11101-7327	EAOEA/D/E/F
	65.11101-7374	EAOEB/C/G
	65.11101-7353	EAOLA/B
DB58TIS	65.11101-7391	ECOEA/B
	65.11101-7389A	ECOEC/D/E/F/G
	65.11101-7392	ECOLA
	65.11101-7390	ECOLB

2) Injection nozzle assembly

Engine model	Part no.	Suffix
DB58 DB58T	65.10101-7295	EARDA/EAREA/B EARFA/B/C/D/F/G/K/EARLA/B/C EATEA/B/C/D/E/F/G/H/I/J/EATLA/B
DB58 DB58S	65.10101-7086	EARFE/H/I/J ECRFA/B/C/ECRLA
DB58TI DB58TIS	65.10101-7058	EAOEA/B/C/D/E/G/EAOLA/B
	65.10101-7092	EAOEF/ECOEA/B
DB58TIS	65.10101-7091	ECOEC/D/E/F/G/ECOLB

3) Injection pipe assembly

Engine model	Part no.	Suffix
DB58 DB58S	65.10301-6144	EARDA/EAREA/B EARFA/B/C/D/E/F/G/H/I/J/K EARLA/B/C/ECRFA/B/C/ECRLA
DB58T	65.10301-6289	EATEA/B/C/D/E/F/G/H/I/J/EATLA/B
DB58TI	65.10301-6072	EAOEA/B/C/D/E/F/G/EAOLA/B
DB58TIS	65.10301-6088 65.10301-6089	ECOEA/B/C/D/E/F/G/ECOLA/B

6) Rack diagram and setting valve at each point

a) DB58 : EATEE/TEH/TLB

Check Point	Rack position (mm)	Pump speed (rpm)	Injection Q'ty on RIG (mm ³ / 1,000st)	Pressure (mmHg)
A	8.8	1,100	73.5 ±1.5	Above 300
B	9.1	800	9.4 ±1.3	-
C	≈6.7	415	(63)	Above 300
D	-	100	(43.6) ±2	-

b) DB58 : EATEF

Check Point	Rack position (mm)	Pump speed (rpm)	Injection Q'ty on RIG (mm ³ / 1,000st)	Pressure (mmHg)
A	8.8	1,100	73.5 ±1.5	Above 300
B	9.1	800	9.4 ±1.3	-
C	≈6.7	415	(63)	Above 300
D	-	100	46.6 ±10	-

c) DB58 : EATEG

Check Point	Rack position (mm)	Pump speed (rpm)	Injection Q'ty on RIG (mm ³ / 1,000st)	Pressure (mmHg)
A	8.8	1,100	72.0 ±1.5	Above 300
B	9.1	800	9.4 ±1.3	-
C	≈6.7	415	(60)	Above 300
D	-	100	53 ±10	-

d) DB58 : EATEI

Check Point	Rack position (mm)	Pump speed (rpm)	Injection Q'ty on RIG (mm ³ / 1,000st)	Pressure (mmHg)
A	8.8	1,100	67.0 ±1.5	Above 300
B	9.1	800	9.4 ±1.3	-
C	≈6.7	415	(57)	Above 300
D	-	100	50 ±10	-

e) Rack curve and boost pressure of standard injection pump(65.11101-7374)

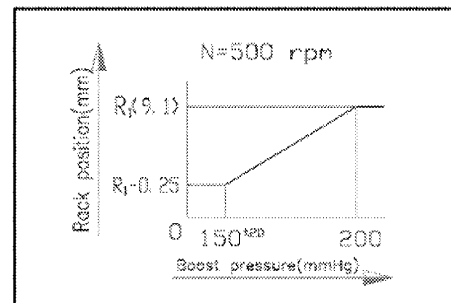
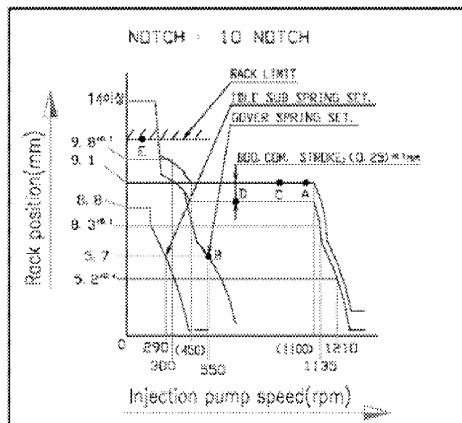

6) Rack diagram and setting valve at each point

a) DB58TIS : ECOEC

Check Point	Rack position (mm)	Pump speed (rpm)	Injection Q'ty on RIG (mm ³ / 1,000st)	Pressure (mmHg)
A	R1(10.3)	1,100	109 ±1.5	Above 450
B	6.6	600	22 ±2.0	-
C	R1	500	(97)	Above 450
D	(R1-1.5)	500	(61)	-
E	-	100	96±10	-

b) DB58TIS : ECOED

Check Point	Rack position (mm)	Pump speed (rpm)	Injection Q'ty on RIG (mm ³ / 1,000st)	Pressure (mmHg)
A	R1(10.3)	1,100	91 ±1.5	Above 450
B	6.6	600	22 ±2.0	-
C	R1	500	(81)	Above 450
D	(R1-1.5)	500	(53)	-
E	-	100	96±10	-

c) DB58TIS : ECOEE

Check Point	Rack position (mm)	Pump speed (rpm)	Injection Q'ty on RIG (mm ³ / 1,000st)	Pressure (mmHg)
A	R1(10.3)	1,100	113 ±1.5	Above 450
B	6.6	600	22 ±2.0	-
C	R1	500	(101)	Above 450
D	(R1-1.5)	500	(61)	-
E	-	100	96±10	-

d) DB58TIS : ECOEF

Check Point	Rack position (mm)	Pump speed (rpm)	Injection Q'ty on RIG (mm ³ / 1,000st)	Pressure (mmHg)
A	R1(10.3)	1,100	95 ±1.5	Above 450
B	6.6	600	22 ±2.0	-
C	R1	500	(84)	Above 450
D	(R1-1.5)	500	-	-
E	-	100	96±10	-

e) DB58TIS : ECOEG

Check Point	Rack position (mm)	Pump speed (rpm)	Injection Q'ty on RIG (mm ³ / 1,000st)	Pressure (mmHg)
A	R1(10.3)	1,100	111 ±1.5	Above 450
B	6.6	600	22 ±2.0	-
C	R1	500	(99)	Above 450
D	(R1-1.5)	500	(61)	-
E	-	100	96±10	-

f) Rack curve and boost pressure of standard injection pump(65.11101-7389)

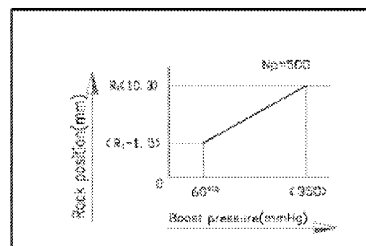
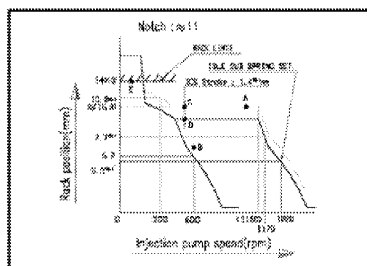

2) Compressor

The compressor, which is connected to the turbine over the one and same shaft to form a rotating body, takes in and compresses ambient air with rotating force transmitted from the turbine shaft. Then, the compressed air is delivered to the intake stake. This is the operating principle of the compressor.

3) Bearings

(1) Thrust bearing

The turbine wheel creates thrust force. Therefore, exercise care so that the shaft is not deviated from its the original position due to this thrust.

(2) Journal bearing

This journal bearing of floating type forms a dual oil film on both the inside and outside of the bearing so that the bearing can rotate independently. As the dual oil film plays a role as a damper, the sliding speed of the bearing surface becomes lower than the rotating speed of the shaft, resulting in assurance of stability in its movement.

4) Sealing-compressor shaft

The compressor is of a dual construction type composed of seal plate and seal ring to prevent the leak of compressed air or lubricating oil.

5.4.4. Precautions for operation

1) Precautions for operation of engine

The following precautions should be observed when starting, operating, or stopping the engine:

Operations	Precautions	Reasons
When starting the engine	1) Check oil level 2) Crank the engine with starter to check the increase in oil pressure(until the needle of pressure gauge starts to move or pressure indicator lamp is actuated) before starting the engine. 3) When having replaced oil, oil filter element, or lubricating parts, or when having stopped the engine for extended period of time, or in a cold place, loosen the oil pipe connections and operate the starter motor until oil is discharged. After completing	2) Abrupt starting of the engine causes the engine to rotate with oil not being distributed not only to each part but also to the turbocharger, resulting in abnormal wear or seizure on the bearing due to insufficient supply of oil. 3) In the case of the engine stopped for extended time or in a cold place, oil fluidity within the pipes can be deteriorated

3) Standard bolt tightening torque table

Refer to the following table for bolts other than described above

Diameter x pitch (mm)	Degree of strength										
	3.6	4.6	4.8	5.6	5.8	6.6	6.8	6.9	8.8	10.9	12.9
	(4A)	(4D)	(4S)	(5D)	(5S)	(6D)	(6S)	(6G)	(8G)	(10K)	(12K)
	Limit value for elasticity (kg/mm ²)										
	20	24	32	30	40	36	48	54	64	90	108
Tightening torque (kg.m)											
M5	0.15	0.16	0.25	0.22	0.31	0.28	0.43	0.48	0.5	0.75	0.9
M6	0.28	0.30	0.45	0.4	0.55	0.47	0.77	0.85	0.9	1.25	0.5
M7	0.43	0.46	0.7	0.63	0.83	0.78	1.2	1.3	1.4	1.95	2.35
M8	0.7	0.75	1.1	1	1.4	1.25	1.9	2.1	2.2	3.1	3.8
M8x1	0.73	0.8	1.2	1.1	1.5	1.34	2.1	2.3	2.4	3.35	4.1
M10	1.35	1.4	2.2	1.9	2.7	2.35	3.7	4.2	4.4	6.2	7.4
M10x1	1.5	1.6	2.5	2.1	3.1	2.8	4.3	4.9	5	7	8.4
M12	2.4	2.5	3.7	3.3	4.7	4.2	6.3	7.2	7.5	10.5	12.5
M12x1.5	2.55	2.7	4	3.5	5	4.6	6.8	7.7	8	11.2	13.4
M14	3.7	3.9	6	5.2	7.5	7	10	11.5	12	17	20
M14x1.5	4.1	4.3	6.6	5.7	8.3	7.5	11.1	12.5	13	18.5	22
M16	5.6	6	9	8	11.5	10.5	17.9	18.5	18	26	31
M16x1.5	6.2	6.5	9.7	8.6	12.5	11.3	17	19.5	20	28	33
M18	7.8	8.3	12.5	11	16	14.5	21	24.2	25	36	43
M18x1.5	9.1	9.5	14.5	12.5	18.5	16.7	24.5	27.5	28	41	49
M20	11.5	12	18	16	22	19	31.5	35	36	51	60
M20x1.5	12.8	13.5	20.5	18	25	22.5	35	39.5	41	58	68
M22	15.5	16	24.5	21	30	26	42	46	49	67	75
M22x1.5	17	18.5	28	24	34	29	47	52	56	75	85
M24	20.5	21.5	33	27	40	34	55	58	63	82	92
M24x1.5	23	25	37	31	45	38	61	67	74	93	103

Others :

1. The above torque rating have been determined to 70% or so of the limit value for bolt elasticity.
2. Tension is calculated by multiplying tensile strength by cross section of thread.
3. Special screws should be tightened to 85% or so of the standard value.
For example, a screw coated with MoS₂ should be tightened to 60% or so of the standard value.

4) Tightening torque for hollow screw(4-hole)

Material	M8	M10	M12	M14	M16	M18	M22	M26	M30	M38
SM25C	-	1.6	2.5	3.5	4.5	5.5	9.0	13.0	18.0	30.0
★SUM22L	0.8	1.8	3.0	4.0	5.5	6.5	11.0	16.0	20.0	35.0
STS304	0.8	1.8	3.0	4.0	5.5	6.5	11.0	16.0	20.0	35.0

★: Adopted in DAEWOO engine

CLICK HERE TO **DOWNLOAD** THE COMPLETE MANUAL

- Thank you very much for reading the preview of the manual.
- You can download the complete manual from: www.heydownloads.com by clicking the link below



- Please note: If there is no response to CLICKING the link, please download this PDF first and then click on it.

CLICK HERE TO **DOWNLOAD** THE COMPLETE MANUAL