

# **D1146, D1146T & D1146TI DIESEL ENGINE**

Shop Manual

65.99892-8035

Daewoo reserves the right to improve our products in a continuing process to provide the best possible product to the market place. These improvements can be implemented at any time with no obligation to change materials on previously sold products. It is recommended that consumers periodically contact their distributors for recent documentation on purchased equipment.

This documentation may include attachments and optional equipment that is not available in your machine's package. Please call your distributor for additional items that you may require.

Illustrations used throughout this manual are used only as a representation of the actual piece of equipment, and may vary from the actual item.

CLICK HERE TO **DOWNLOAD** THE COMPLETE MANUAL

- Thank you very much for reading the preview of the manual.
- You can download the complete manual from: [www.heydownloads.com](http://www.heydownloads.com) by clicking the link below



- Please note: If there is no response to CLICKING the link, please download this PDF first and then click on it.

CLICK HERE TO **DOWNLOAD** THE COMPLETE MANUAL

1.3.3. D1146TI

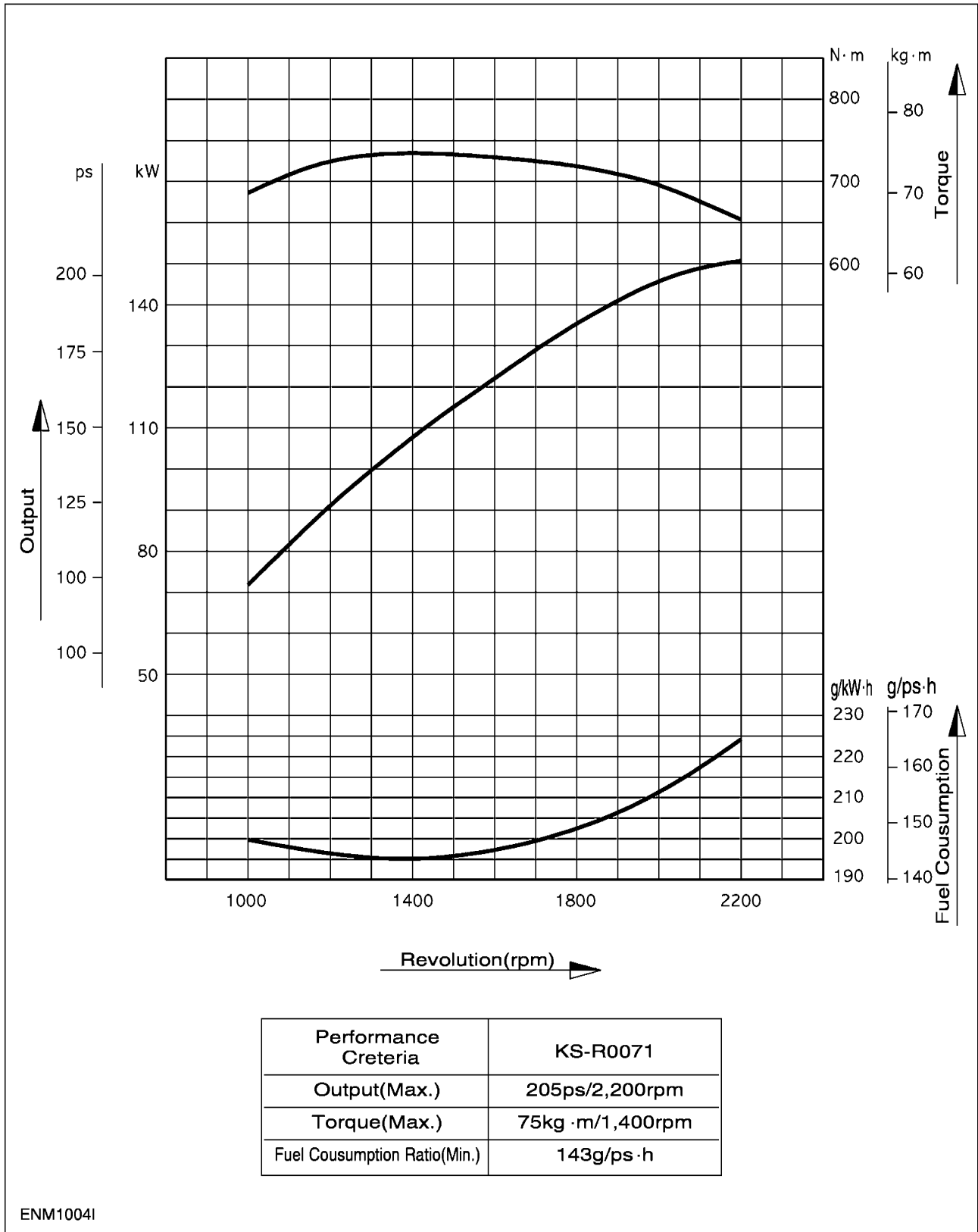

<Fig.4>

### 3. Lack of Power

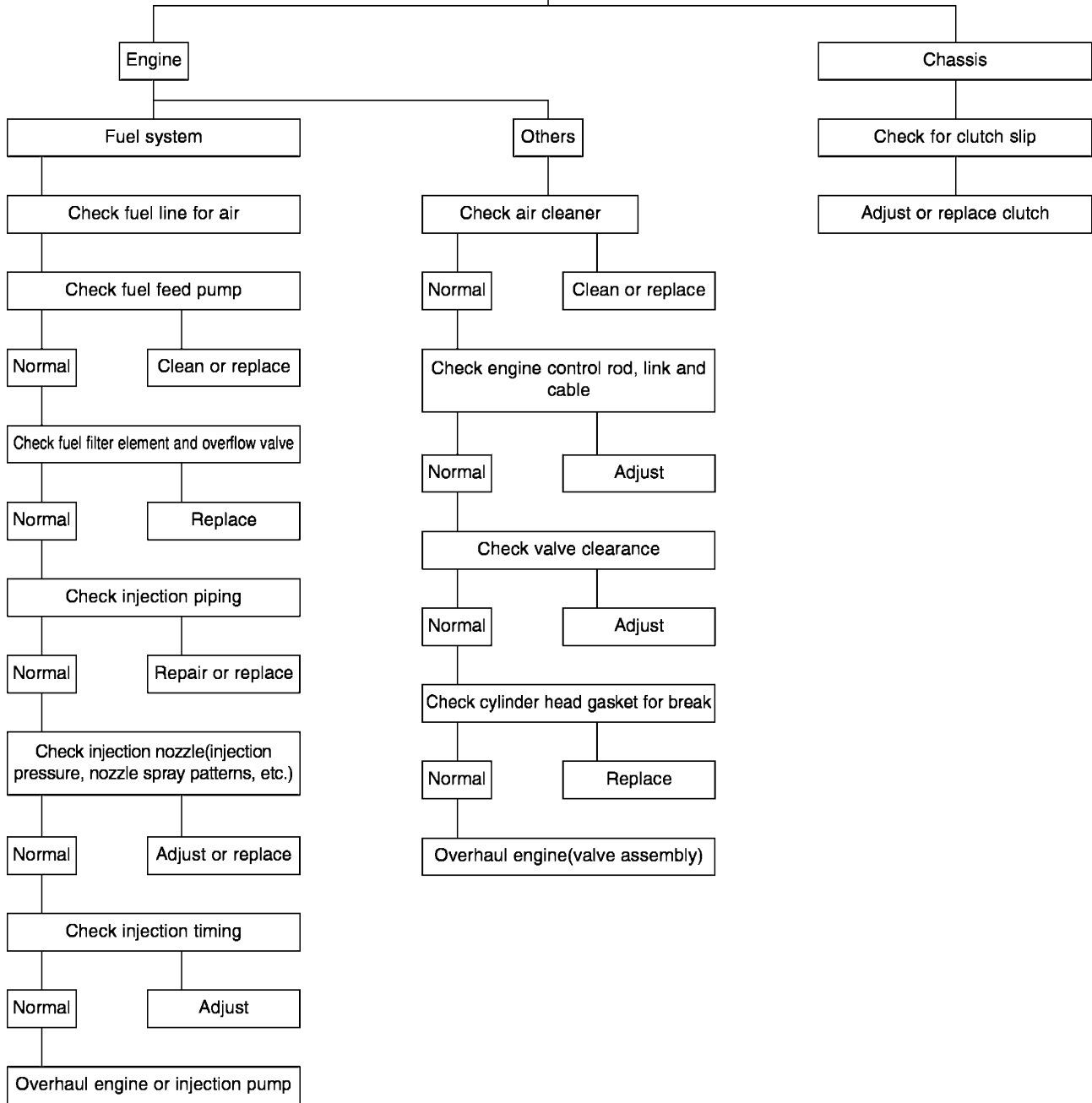

### 3.1.10. Breather Pipe

- 1) Unscrew the hose clamp with a screw driver and remove the breather pipe.  
(There are two types of breather pipes according to their mounting locations. that is, on the oil cooler and on the cylinder head cover)

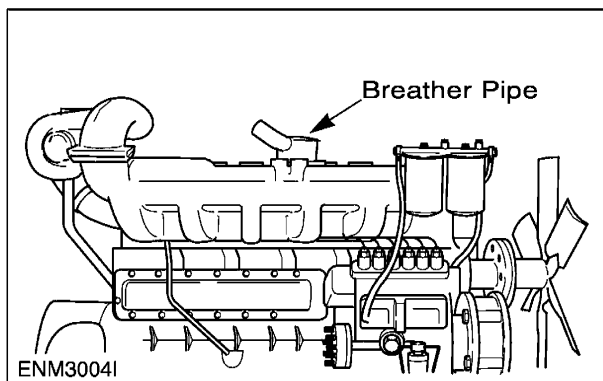

<Fig. 6> Breather Pipe (On The Cylinder Head Cover)

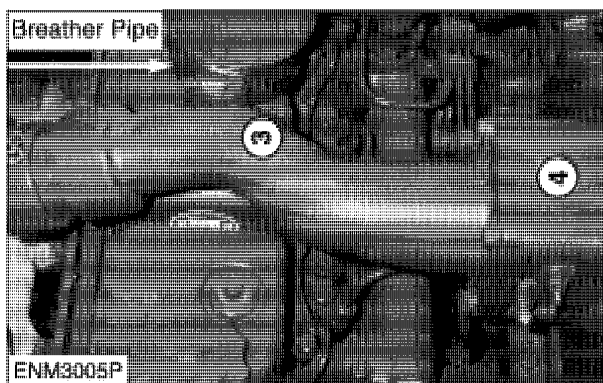

<Fig. 7> Breather Pipe (Top View)

### 3.1.11. Alternator

- 1) Remove the alternator fixing bolts and take off the alternator.

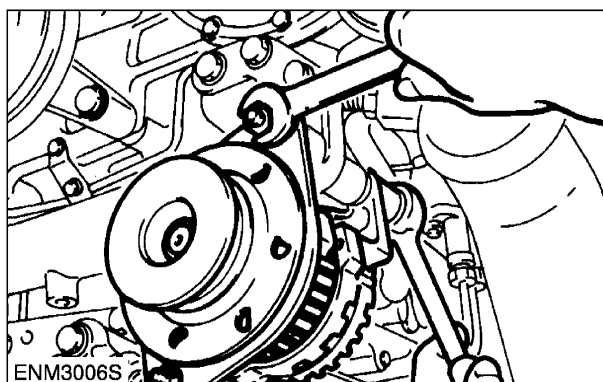

<Fig. 8> Alternator Disassembling

### 3.1.12. Oil Cooler

- 1) Loosen the rubber hose clamps of both sides of the oil cooler.
- 2) Unscrew the nuts and take off the oil cooler.

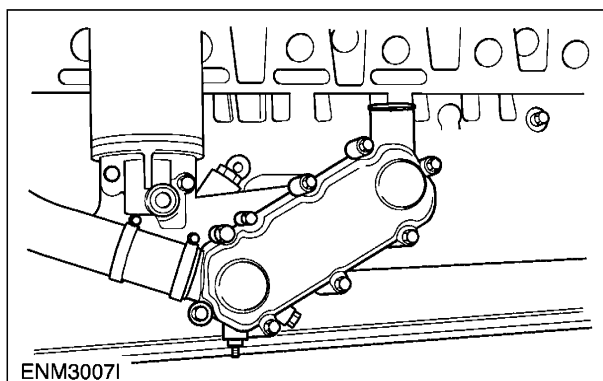

<Fig.9> Oil Cooler

### 3.1.31. Fuel Injection Pump

- 1) Remove the oil hose for lubrication.
- 2) Unscrew the injection pipe fixing bolts and remove the injection pipe.

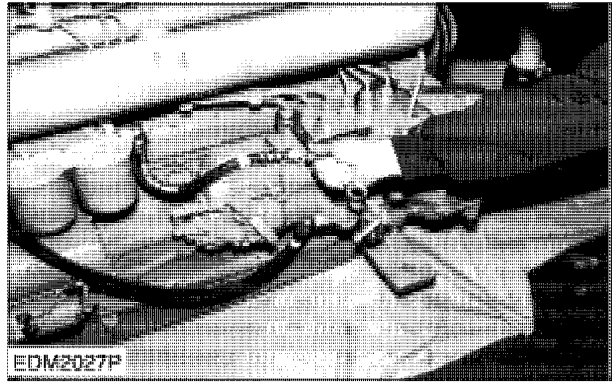

<Fig.36> Injection Pipe Removal

- 3) Remove the bolts and nuts which connect the coupling flange. To the injection pump.

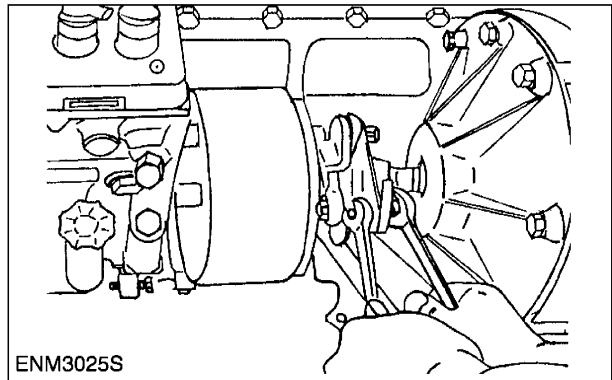

<Fig.37> Coupling Disassembling

- 4) Unscrew the injection pump fixing bolts and remove the injection pump by lifting it up.

- 5) Unscrew the bracket fixing bolts and remove the bracket while tapping it lightly with a urethane hammer.

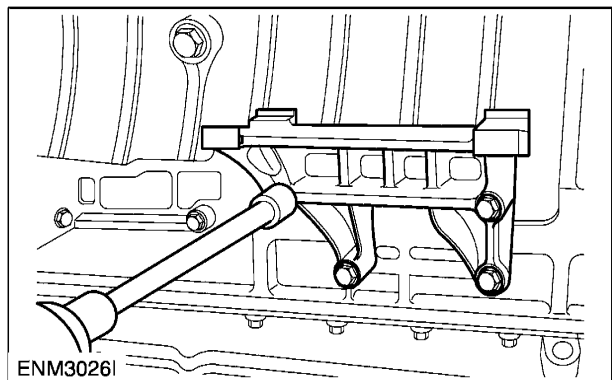

<Fig.38> Bracket Disassembling

CLICK HERE TO **DOWNLOAD** THE COMPLETE MANUAL

- Thank you very much for reading the preview of the manual.
- You can download the complete manual from: [www.heydownloads.com](http://www.heydownloads.com) by clicking the link below



- Please note: If there is no response to CLICKING the link, please download this PDF first and then click on it.

CLICK HERE TO **DOWNLOAD** THE COMPLETE MANUAL

**Note :** When regrinding the crank shaft, the fillet "R" should be correctly finished. Avoid stepped portion or rough surface on it.

Standard Value for "R" Portion

Crankshaft pin "R" (mm)	4.5
Crankshaft journal "R" (mm)	4.0

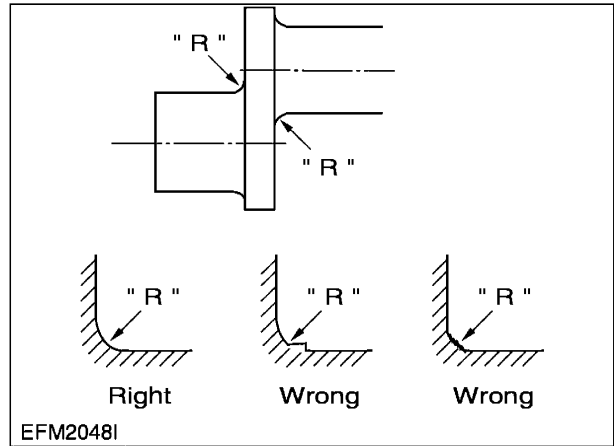

<Fig.56> "R" Formation of Crank Shaft

3) Run-Out of Crank Shaft

- (1) Place the crank shaft with its No.1 and No.7 journals on two V-blocks respectively.
- (2) Measure the run-out of crank shaft as turning the crank shaft slowly in one direction with the probe of a dial indicator on a crank shaft journal.

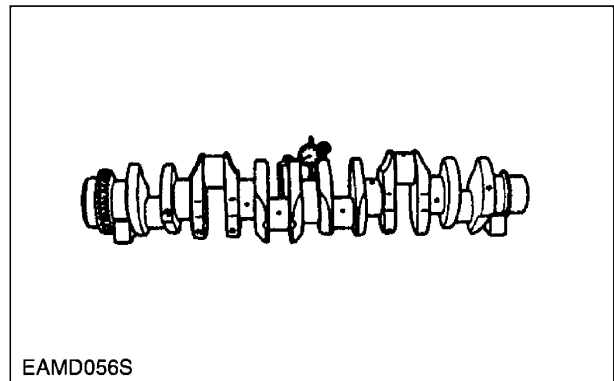

<Fig. 57> Crank Shaft Run-Out Measurement

4) Inspection of Crank Shaft Bearing and Connectingrod Bearing

- (1) Visually inspect the surfaces of crank shaft bearing and connectingrod bearing for scores, scratch or uneven wear.

5) Measurement of Oil Clearance

- (1) Install the main bearing onto the cylinder block and tighten the bearing cap to the specified torque and measure its inner diameter.

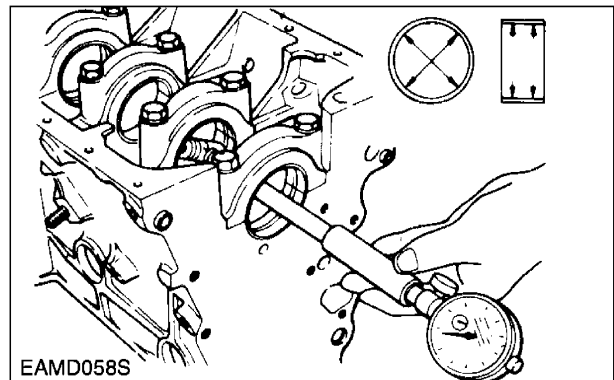

<Fig.58> Main Bearing Inner Dia. Measurement

### 3.3.7. Injection Pump

- 1) Install the injection pump mounting bracket with a shim between the bracket and cylinder block and tighten the bolts.

If the thickness of the original shim is not correct, determine which new shim is to be used.

There are 4 types of shim for adjusting the horizontal alignment such as 0.1mm, 0.15mm, 0.2mm and 0.5mm in thickness and there are also 3 types of shim for adjusting the vertical alignment such as 0.1mm, 0.2mm and 0.3mm in thickness.

- 2) Mount the injection pump on the bracket, then tighten the bolts to the specified torque.
- 3) Assemble the coupling as checking the alignment between injection pump shaft and drive gear shaft.

If the alignment is not achieved, do disassembling and replace the shim with correct one and reassemble the mounting bracket and the injection pump.

- 4) Rotate the flywheel in direction of rotation until the mark on the vibration damper exactly meets the pointer.
- 5) Align the pointer on the injection pump with the line on timer, and couple the injection pump to the coupling drive shaft by tightening fixing bolts and nuts.

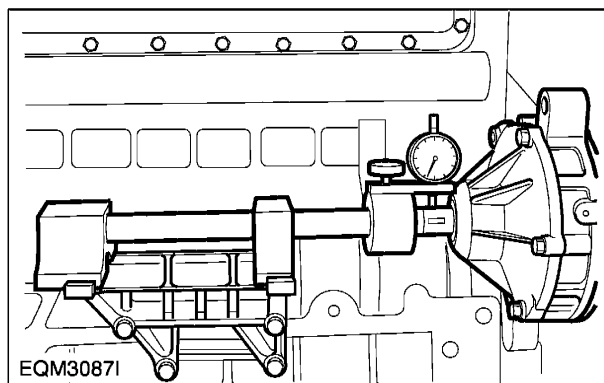

<Fig. 80> Injection Pump Assembling

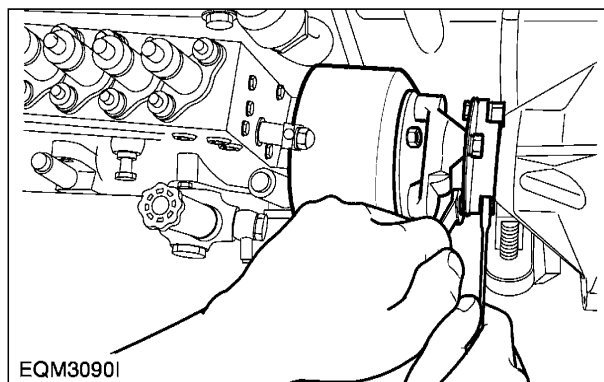

<Fig.81> Injection Pump Marking

### 3.3.8. Cylinder Liner

- 1) Completely clean the cylinder liners and blow off the dust and water by compressed air.
- 2) Insert the cylinder liner into the cylinder block and push the cylinder liner with hands. (Be careful that no foreign objects get in the bottom side of liner flange when assembling)
- 3) Coat engine oil inside the liner.



<Fig.82> Cylinder Liner Assembling

### 3.3.20. Intake Manifold

- 1) Install the manifold gasket on the cylinder head by aligning its openings with the intake port in the cylinder head.
- 2) Install the intake manifold on the cylinder head by means of bolts and tighten them to the specified torque.

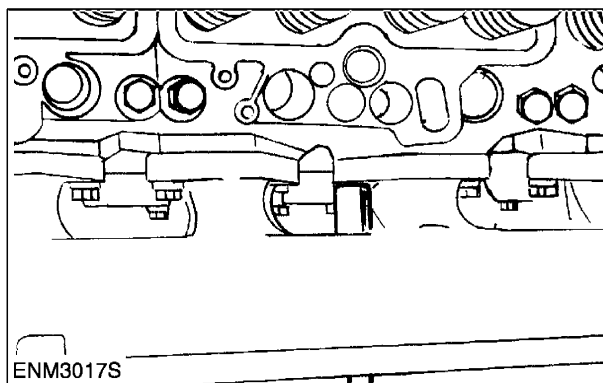

<Fig. 107> Intake Manifold Assembling

### 3.3.21. Inter Cooler < For D1146TI only>

- 1) Remove gasket residue on the joining surface of inter cooler by means of a scraper.
- 2) Coat the surface with silicon adhesive (spec: TB1107) using a brush.
- 3) Insert a new gasket (5) between intake manifold(4) and intercooler(3), then tighten the fixing bolts to the specified torque of 2.2kg·m

**Notice :** For overland use, the inter cooler is mounted on the vehicle side.

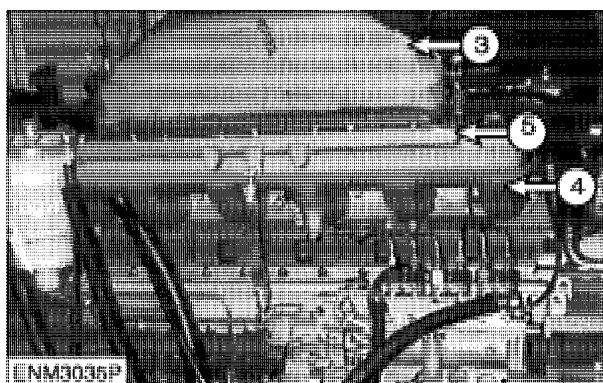

<Fig. 108> Intercooler Assembling

### 3.3.22. Air Heater

- 1) The air heater(2) is ,in the direction of arrow mark on it, assembled to the inter cooler(3).
- 2) Attach the gaskets on both sides of air heater and tighten the fixing bolts respectively.

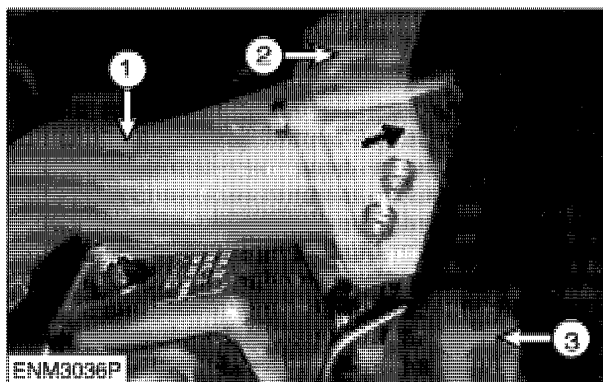

<Fig.109> Air Heater Assembling

- (2) Coat the multipurposable grease over the periphery of unit bearing body and press it into the housing.

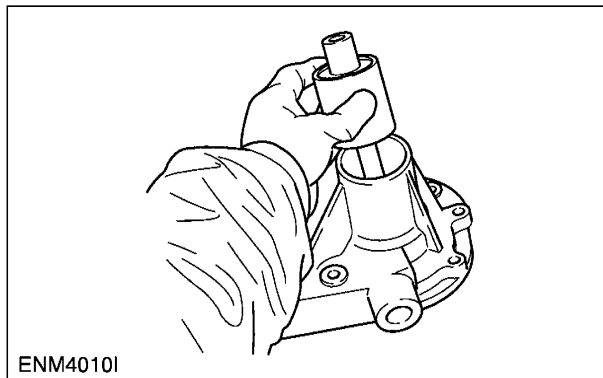

<Fig. 8> Unit Bearing Assembling

- (3) Insert the snap ring into the housing to secure the unit bearing.

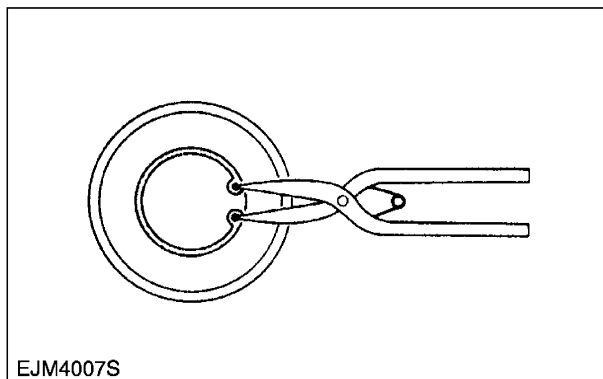

<Fig.9> Snap Ring Inserting

- (4) Press the impeller into the shaft of the unit bearing.

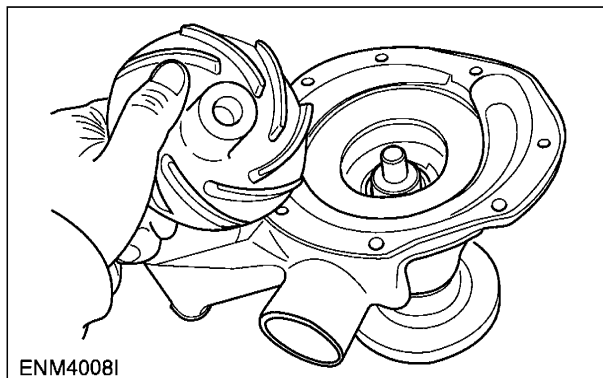

<Fig.10> Impeller

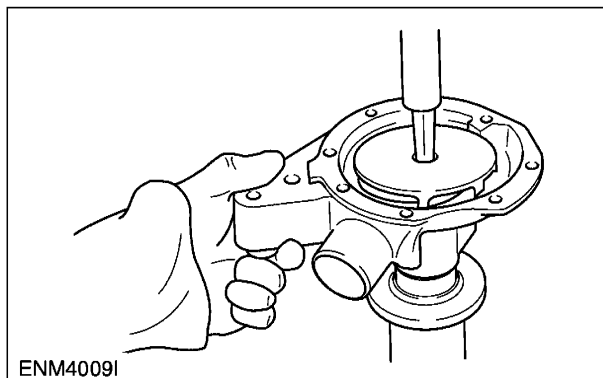

<Fig.11> Impeller Press In

### 3) Disassembly

- (1) Clamp the nozzle assembly and remove the nozzle holder.
- (2) Remove the nozzle nut and components inside.

### 4) Inspection

- (1) Visually Inspect the disassembled components for damage.

### 5) Reassembly

- (1) To reassemble, follow the disassembly procedures in the reverse sequence.

### 6) Nozzle Spray Test

- (1) After reassembly, install the nozzle on a tester.
- (2) Operate the hand lever 2 or 3 times to see if the nozzle is properly set in position.
- (3) When the injection pressure deviates from the specified range. adjust the spring tension by means of the shim. Besides, spray pattern should be uniform and free of spattering.

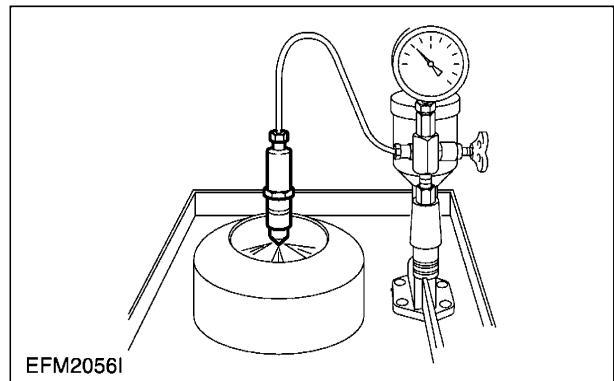

<Fig.4> Nozzle Spray Test

#### 4.5.5. Construction

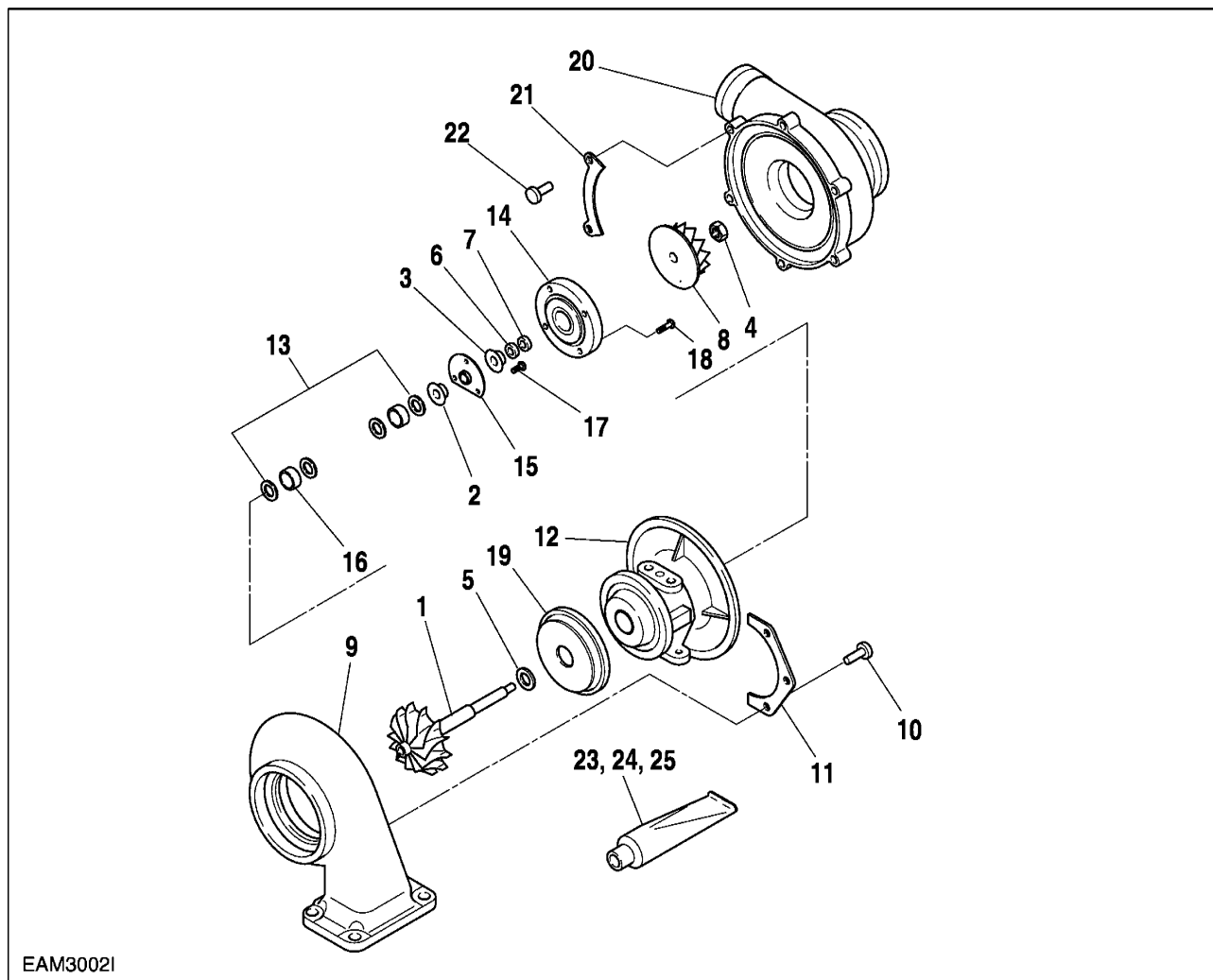

No	Part	No	Part
1	Shaft & Turbine Wheel Ass'y	14	Seal Plate
2	Thrust Bush	15	Thrust Bearing
3	Oil Thrower	16	Journal Bearing
4	Lock Nut	17	Screw
5	Seal Ring; Turbine Side	18	Screw
6	Seal Ring; Large	19	Heat Protector
7	Seal Ring; Small	20	Compressor Housing
8	Compressor Wheel	21	Clamp
9	Turbine Housing	22	Bolt
10	Bolt	23	Liquid Gasket
11	Clamp	24	Loctite
12	Bearing Housing	25	Anti-seize Sealing Liquid
13	Retaining Ring		

CLICK HERE TO **DOWNLOAD** THE COMPLETE MANUAL

- Thank you very much for reading the preview of the manual.
- You can download the complete manual from: [www.heydownloads.com](http://www.heydownloads.com) by clicking the link below



- Please note: If there is no response to CLICKING the link, please download this PDF first and then click on it.

CLICK HERE TO **DOWNLOAD** THE COMPLETE MANUAL