D180

(Tier 3)

CRAWLER DOZER

Workshop Manual

Print No. 84151290 English



THIS ALERT SYMBOL SIGNALS IMPORTANT MESSAGES INVOLVING YOUR SAFETY.

Read and heed carefully the safety instructions listed and follow the precautions recommended to avoid potential risks and to safeguard your health and your safety.

You will find this symbol in the text of this Manual referred to the following key words:

WARNING - Cautions directed to avoid improper repair interventions involving potential consequences for the safety of the personnel performing the repairs.

DANGER - These warnings qualify specifically potential dangers for the safety of the operator or other persons directly or indirectly involved.

IMPORTANT NOTICE

All maintenance and repair interventions explained in this Manual **must be performed exclusively by the Service Organisation of the Manufacturer**, observing strictly the instructions explained using, whenever necessary, the recommended specific tools.

Whoever performs the operations reported without following exactly the precautions is responsible on his own, for the damages that may result.

Neither the Factory nor any Organisations in its Distribution Network, including but not limited to national, regional or local distributors, are responsible for any liability arising from any damage resulting from defects caused by parts and/or components not approved by the Factory for use in maintaining and/or repairing products manufactured or merchandised by the Factory.

In any case, no warranty of any kind is made or shall be imposed with respect to products manufactured or merchandised by the Factory, when failures are caused by the use of parts and/or components not approved by the Factory.

CLICK HERE TO **DOWNLOAD** THE COMPLETE MANUAL

- Thank you very much for reading the preview of the manual.
- You can download the complete manual from: www.heydownloads.com by clicking the link below



- Please note: If there is no response to CLICKING the link, please download this PDF first and then click on it.

CLICK HERE TO **DOWNLOAD** THE COMPLETE MANUAL

SAFETY RULES

- Do not place the body, limbs or fingers into sharp articulation uncontrolled openings of the machine and without proper protections, unless they are blocked in a safe manner.
 - Never perform interventions with engine running, except as called for in a Manual. Do not wear loose clothing or jewellery near moving parts.
 - When servicing or maintenance require access to areas that cannot be reached from the ground, use a ladder or step platform that meet local and national regulations, to reach the service point. If such ladder or platform are not available, use the machine hand holds and steps as provided. Perform all service or maintenance carefully.
 - Shop and/or field service platforms or ladders must be constructed and maintained in accordance with local and national regulations.
 - Disconnect batteries and tag all controls according to current regulations to warn that work is in progress. Block machine and all attachments that must be raised according to current regulations.
- Due to the presence of flammable fluids, never check or fill fuel tanks, batteries, nor use starting fluid near lighted smoking materials or open flames.
- BRAKES ARE INOPERATIVE when manually released for servicing. Provisions must be made to maintain control of the machine by blocking or other means.
 - The fuel filling nose must be kept constantly inside the filling neck. Keep this contact from the beginning to the end of the fuelling operation to avoid the possibility that sparks due to static electricity are generated.
 - Use only designated towing or attaching points. Use care in making attachments. Make sure pins and/or locks are secure before pulling. Stay clear of drawbars, cables or chains under load.
 - To move a disabled machine, use a trailer or a low-boy, if available. In case towing is needed, use all necessary signals required by local and national regulations, and follow the directions provided in this Manual.
 - To load/unload a machine from transporter, choose a level surface ensuring firm support to the wheels of truck or trailer. Use strong access ramps, with adequate height and angle. Keep surface free of mud, oil or slippery materials.
 - Anchor the machine securely to the bed of truck or trailer and block wheels or tracks with appropriate wedges.
- Never align holes with fingers or hands; always use appropriate aligning tools.
 - Eliminate all sharp edges and burrs from re-worked parts.
 - Use only approved grounded auxiliary power sources for heaters, chargers, pumps and similar equipment to reduce the hazards of electrical shocks.
 - Lift and handle heavy parts with a lifting device of proper capacity. Be sure parts are supported by proper slings and hooks. Use lifting eyes if provided. Watch-out for people in the vicinity.
 - Never pour gasoline or diesel fuel into open, wide and low containers. Never use gasoline, solvent or other flammable fluid to clean parts. Use exclusively qualified, non-flammable, non-toxic commercial solvents.
 - When using compressed air for cleaning parts, use safety glasses with side shields or goggles. Limit pressure to 2 bar, in accordance with local and national regulations.
 - Do not run the engine in closed areas without proper ventilation to remove deadly exhaust fumes.
 - Do not smoke or permit any open flames or spark near when re-fuelling or handling flammable materials.
 - Do not use an open flame as a light source to look for leaks or for inspection anywhere on the machine.
 - Make sure that all mechanic's tools are in good conditions. NEVER USE tools with mushroomed heads or frayed. Always wear eye protections.
 - Move with extreme care when working under the machine, its attachments and or on or near them. Always wear protective safety equipment as required, such as hard hat, goggles, safety shoes, ear plugs.
 - When performing operations requiring running of the engine, have a qualified operator in the operator's seat at all times with the mechanic on sight. Place the transmission in neutral and set the brakes and safety lock.
 - KEEP HANDS AND CLOTHING AWAY FROM MOVING PARTS.
 - For field service, move machine to level ground, if possible, and block it. If work on an incline is absolutely necessary, first block machine and its attachments securely, than move it to level ground as soon as possible.

DIMENSION D180 PAT

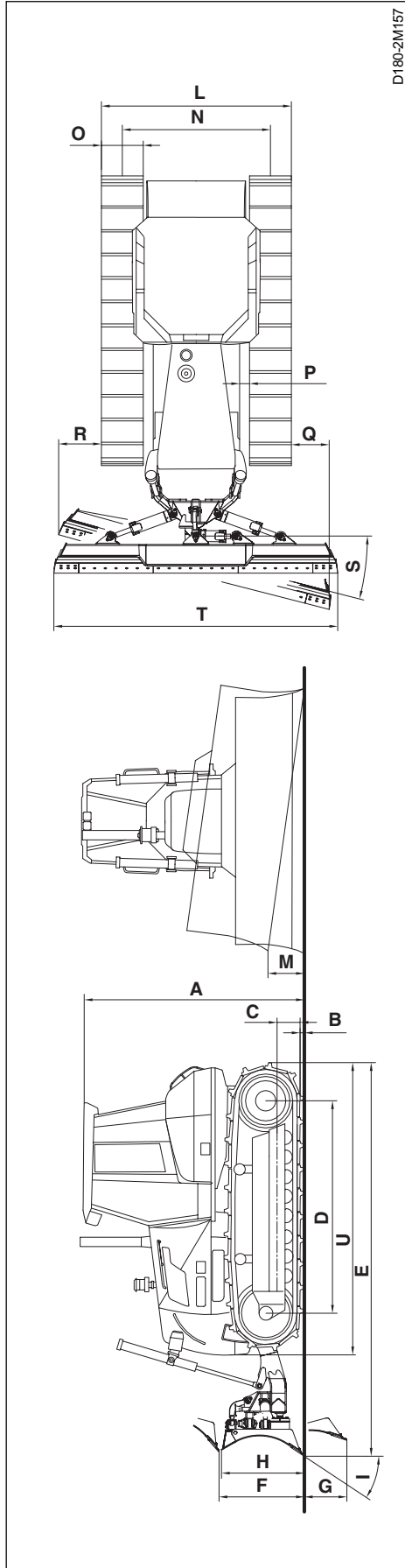

TRACTOR DIMENSION

		LTPAT	XLT PAT	LGP PAT
Blades dimensions	m ³	12 ft (144 in.)	12 ft (144 in.)	13.5 ft (162 in.)
Blade capacity SAE J1265	mm	3235 (127.4 in.)	3235 (127.4 in.)	3235 (127.4 in.)
A Height over cab	mm	71.5 (2.8 in.)	71.5 (2.8 in.)	71.5 (2.8 in.)
B Shoe grouser height	mm	390 (15.3 in.)	390 (15.3 in.)	390 (15.3 in.)
C Luce libera da terra	mm	2700 (106.2 in.)	3205 (126.2 in.)	3205 (126.2 in.)
D Passo	mm	5617 (221.1 in.)	5931 (233.5 in.)	5931 (233.5 in.)
E Lunghezza macchina con lama	mm	1133 (44.6 in.)	1260 (49.6 in.)	1260 (49.6 in.)
F Sollevamento lama da terra	mm	776 (30.1 in.)	800 (31.5 in.)	800 (31.5 in.)
G Profondità di scavo	mm	1324 (52.1 in.)	1324 (52.1 in.)	1324 (52.1 in.)
H Ground clearance	mm	33.5 (1.3 in.)	33.5 (1.3 in.)	33.5 (1.3 in.)
I Cutting edge angle	mm	2460 (96.8 in.)	2460 (96.8 in.)	2460 (96.8 in.)
L Overall width with shoes 560 (22 in)	mm	2510 (98.8 in.)	2510 (98.8 in.)	2510 (98.8 in.)
Overall width with shoes 610 (24 in)	mm	19089 (42084 lb)	20325 (44809 lb)	2844 (112 in.)
Overall width with shoes 762 (29.9 in)	kg	480 (18.9 in.)	480 (18.9 in.)	21059 (46427.1 lb)
Shipping weight w blade***	mm	568 (22.4 in.)	568 (22.4 in.)	568 (22.4 in.)
M Blade tilt (7.6 DEG)	mm	1900 (74.8 in.)	1900 (74.8 in.)	1900 (74.8 in.)
N Gauge	mm	560-610 (22-24 in.)	560-610 (22-24 in.)	560-610 (22-24 in.)
O Track shoes width	mm	100 (3.9 in.)	100 (3.9 in.)	100 (3.9 in.)
P Minimum distance shoes-mainframe	mm	184 (7.2 in.)	184 (7.2 in.)	184 (7.2 in.)
Q Cut reach	mm	614 (24.2 in.)	614 (24.2 in.)	614 (24.2 in.)
R Cast reach	mm	3610 (142.1 in.)	3610 (142.1 in.)	3610 (142.1 in.)
S Blade angle	deg	25°	25°	25°
T Width of blade	mm	4195 (165.1 in.)	4340 (170.9 in.)	4340 (170.9 in.)
U Tractor length	mm	20382 (44934.6 lb)	21754 (47959.6 lb)	22488 (49578 lb)
Operating weight with blade*	kg	20518 (45234.6 lb)	21754 (47959.6 lb)	22488 (49578 lb)

* Includes ROPS Cab, 610 mm (24 in) shoes (915 mm (36 in) for LGP), fuel oil and operator, for unit with ROPS canopy deduct 300 kg (661.4 lb).
 ** With ripper raised, add 935 mm (36.8 in) to dozer length.
 *** Includes ROPS Cab, 610 mm (24 in) shoes (915 mm (36 in) for LGP), 10% fuel, blade lift cylinders, lubricants, coolant.

TECHNICAL DATA D180

HYDRAULIC SYSTEM	Tool control valve: Piloted electr., Closed centre, flow partition, with unloading valve.	D180 Power Steering	D180 Steering Clutch
		4 spools 5 spools	3 spools
	Brand Model	Rexroth 4M6 - 22 5M6 - 22	Rexroth 3M6 - 15
	1 st spool Tilt blade 2 nd spool Lift blade 3 rd spool Ripper 4 th spool Blade angle 5 th spool Steering		
	Pilot valve BD Single lever for 1 st and 2 nd spool Brand Model	Gessmann M3916	
	Pilot valve PAT Single lever for 1 st and 2 nd and 4 th spool Brand Model	Gessmann M3909	
	Auxiliary lever Single lever for auxiliary spool Brand Model	Gessmann M3915	
	Cylinders: Blade 2-with stroke limitation valve Bore mm (in) Rod diameter mm (in) Stroke mm (in)	95 (3.7) 60 (2.4) 1250 (49.2)	
	Tilt (bulldozer blade) Bore mm (in) Rod diameter mm (in) Stroke mm (in)	140 (5.5) 70 (2.7) 126 (4.9)	
	Tilt (angledozer blade) Bore mm (in) Rod diameter mm (in)	110 (4.3) 63 (2.5)	

LIST OF WEIGHTS FOR MAIN SERVICE COMPONENTS

	kg	lb
Engine assembly without air cleaner and silencer	550	1212.5
Torque converter assembly (with pumps)	161	355
Torque converter + housing	91	201
Main pump (D180 Power Steering)	60	132
Main pump (D180)	50	110
Brake pump	10	22
Transmission & converter pump	10	22
Radiator assembly (empty)	120	265
Universal joint	16	35
Transmission assembly	530	1168
Steering compartment assembly (with final drives)	3060	6747
Steering compartment assembly	1654	3647
Bevel pinion assembly	30	66
Bevel gear set	25	55
Bevel gear shaft	30	66
Steering module assembly (each)	235	518
Starter housing	905	1995
Ring gear	19.1	42
Ring gear, support	12.2	27
Hydraulic motor (D180 Power Steering version)	41	90
Cover assembly (including gears)	122	269
Final drive assembly (each)	703	1550
Pivot shaft	65	143
Swing bar	160	353
Shoes (910 mm (35.82 in), each)	35	77
Track chain assembly (560 mm (22 in) shoes, 40 elements)	1463	3225
Track chain assembly (915 mm (36 in) shoes, 45 elements)	2276	5007
Shoes (560 mm (22 in), each)	21	46
Shoes (610 mm (24 in), each)	23	51
Carriage assembly - LT	1514	3330
Carriage assembly - XLT/LGP	1800	3960
Track roller (each)	53	117
Support roller (each)	32	71
Track chain tensioner assembly	233	514
Idler wheel assembly	212	467
Track guide (each)	20	44
Fuel tank (empty)	180	397

Index no. of material (f)	Class of strength and type of material					
	FIAT	UNI	DIN	SAE	BSI	BNA
0	R 40	D - 4S - 4A		1	A	42
1	R 50	5S - 6S		3	P	56
2	R 80	8G		5	T	80
3	R 100	100	10K	8	V	100
4	Ottone	Ottone	Messing	Brass	Brass	Laiton
5	Alluminio	Alluminio	Aluminium	Aluminium	Aluminium	Aluminium
6	Rame	Rame	Kupfer	Copper	Copper	Cuivre
7	Free from other metal materials					

NOTICES

- Lubricate with engine oil the fixtures up to diameter 24, with tallow for larger diameters.
- The tolerance on tightening torques is $\pm 5\%$.
- The strength classes R80, R100, R120, must be intended as follows:

10.9 supersedes R 100
 12.9 " R 120

} for screws

10 supersedes R 80
 12 supersedes R 100

} for nuts

CDT = cadmium plated; FOSF = phosphatised;
 ZNT = zinc plated.

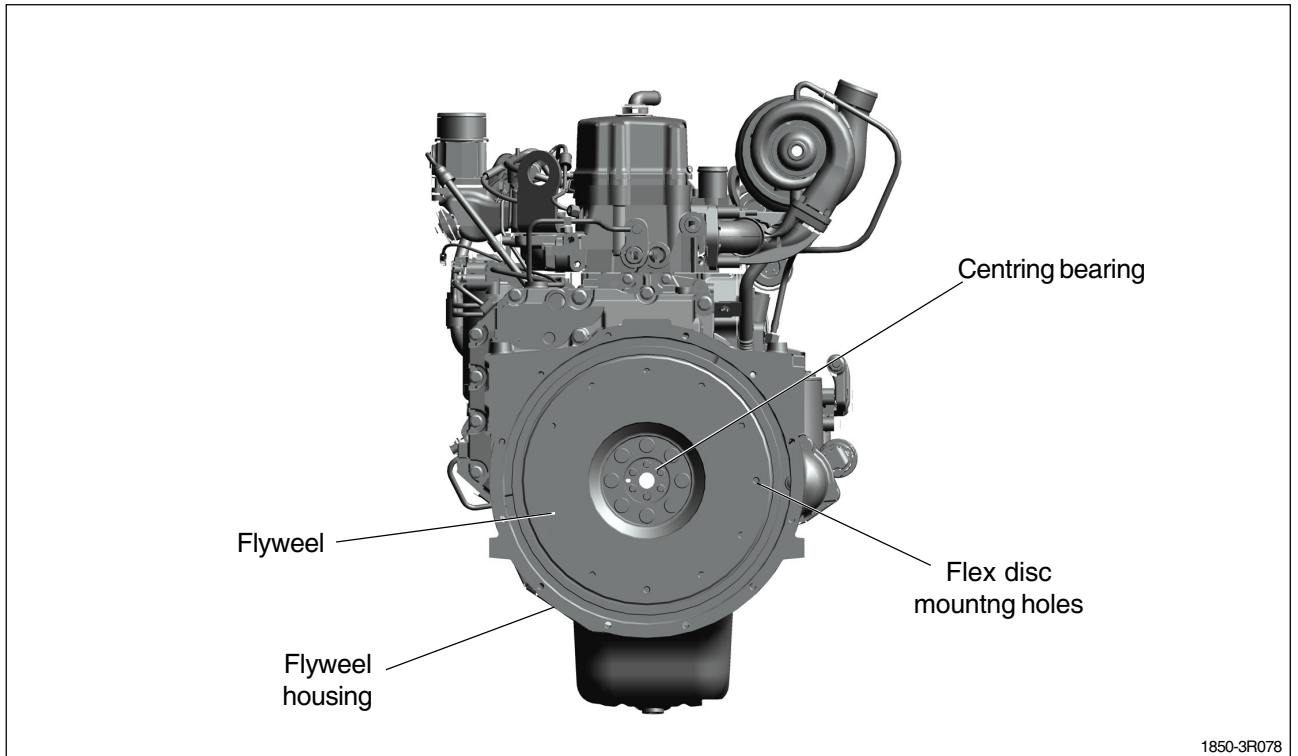

Rear view

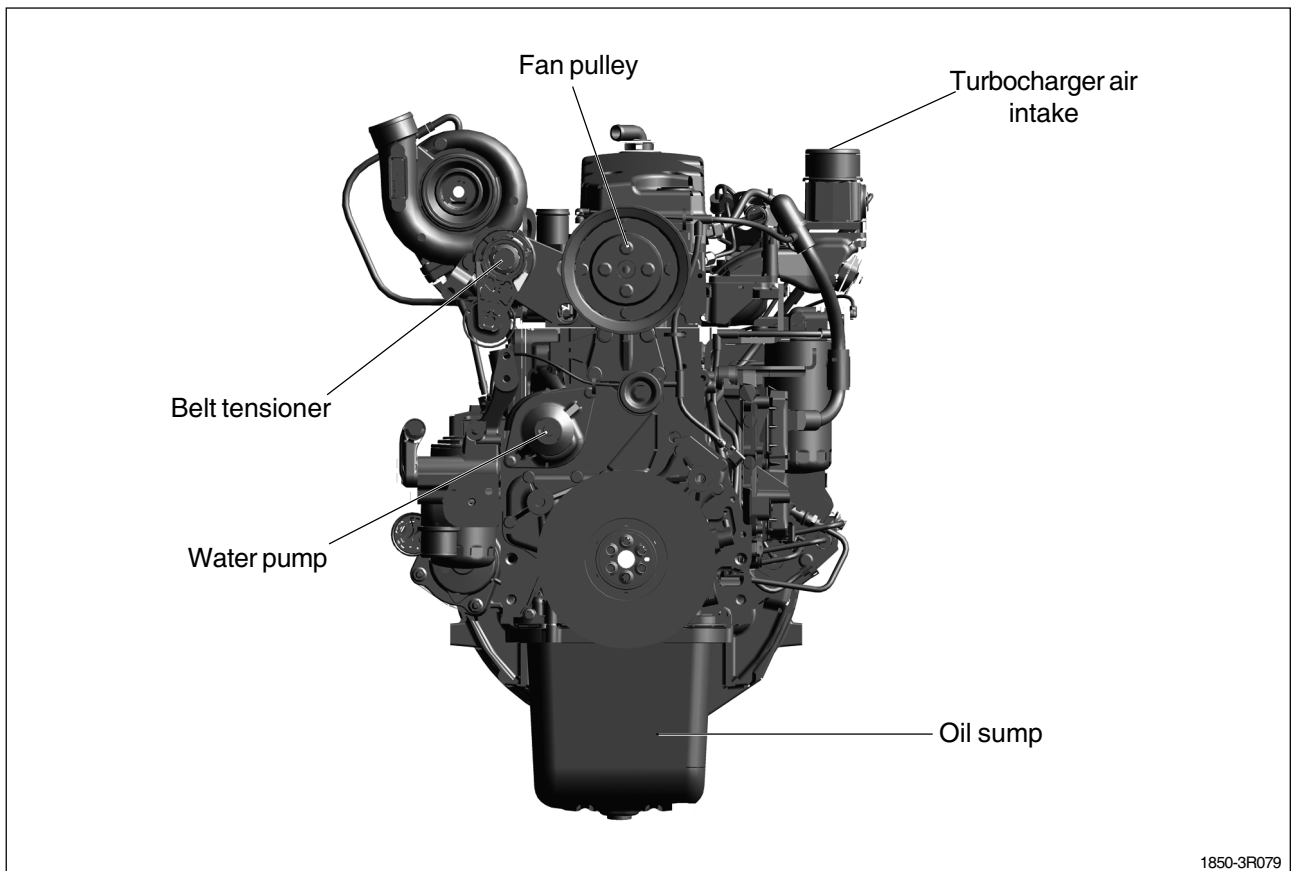

Front view

Disconnect radiator- hydraulic oil hose (2) on the right side, from steel pipe (1) located on the spacer between engine and converter.

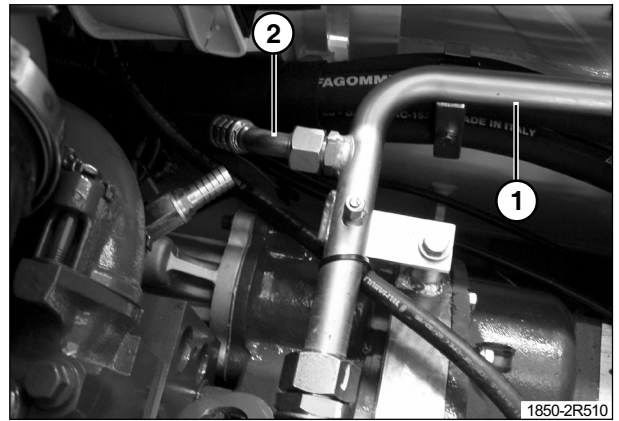

Disconnect radiator - hydraulic oil (delivery) (3) and hose (4) coming from the hydraulic motor from the left side of steel pipe (1).

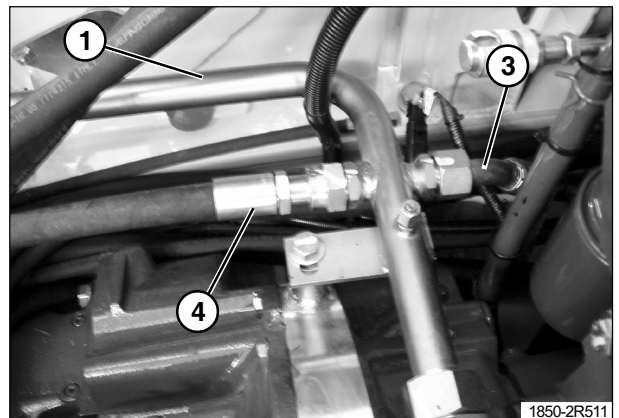

Disconnect hose (5) from the left side of steel pipe (1) after securing bands (6). Proceed in the same manner for the right side of steel pipe (1) disconnecting the relevant hose.

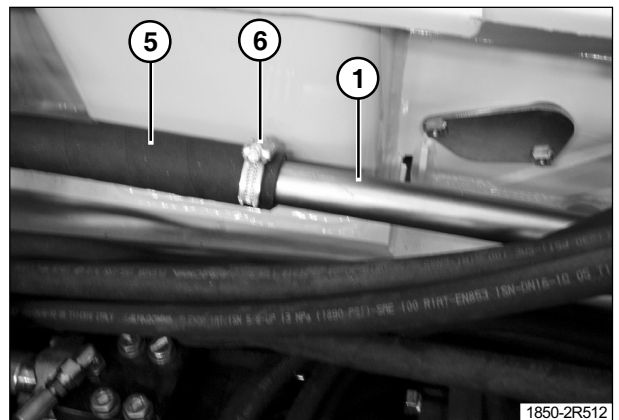

Disconnect steel pipe (1) complete with relief valve (7) by removing screws (8) complete with washers.

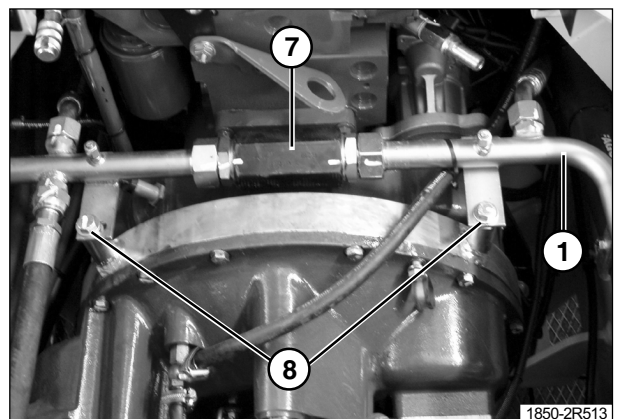

Using a hoist and lifting cables sling the converter group (1) and place it near the engine for the subsequent mounting phase.

 **WARNING**

Lift and handle all heavy materials with lifting devices of appropriate capacity. Make sure that the parts are secured by appropriate hooks and slings. Use the lifting eyes provided for this purpose. Do not stand under suspended loads. Beware of persons in the vicinity of the loads to be lifted.

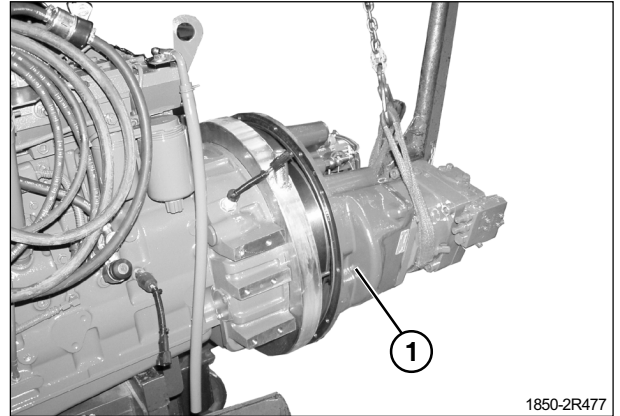

Apply Loctite no.243 on the threaded area of converter securing screws (2) complete with washers (3) and tighten them to a torque of 68 Nm (50 lb.ft.).

 **WARNING**

Do not allow unauthorized persons to repair or maintain this machine. Read carefully the Operation and Maintenance Manual prior to starting, operating, maintaining or refueling and repairing the machine.

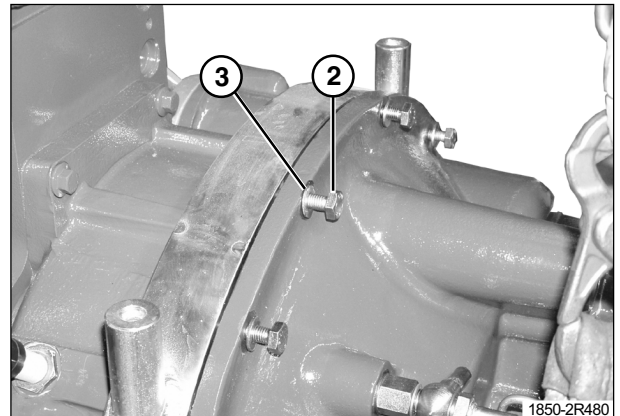

Still on the left side of steel pipe (1) connect hose (2) using securing bands (3).
Proceed in the same manner on the right side of steel pipe (1) connecting the relevant hose.

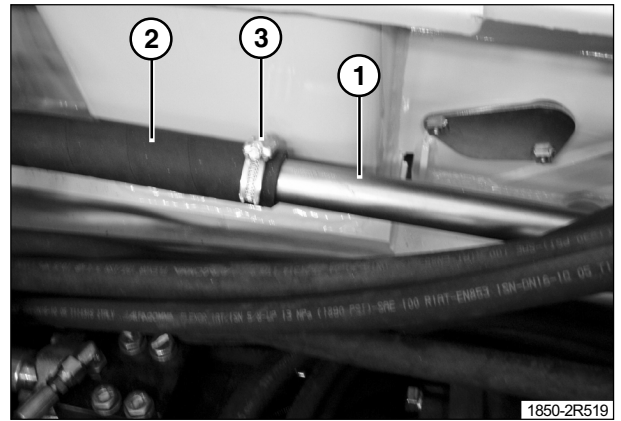

Connect converter oil pressure sensor wire (4) and the hydraulic hoses indicated in the figure. Tighten the hoses in accordance with the tightening torque tables.

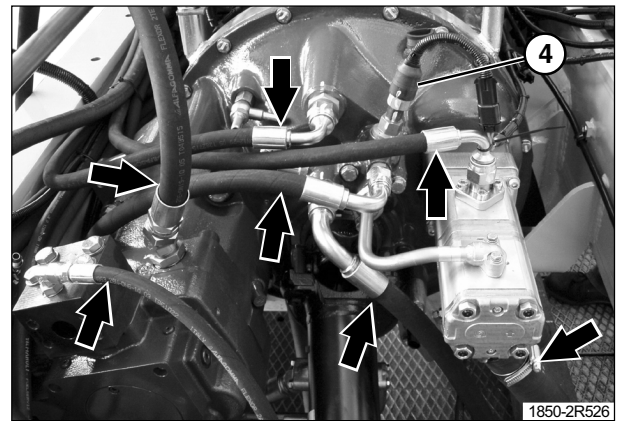

Connect converter oil temperature sensor wire (5).

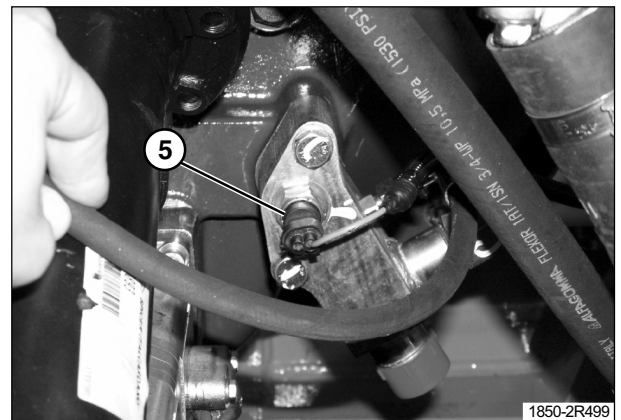

Install radiator fan guard side grills (6) (left and right side) using screws (7) (q.ty 4) complete with washers.

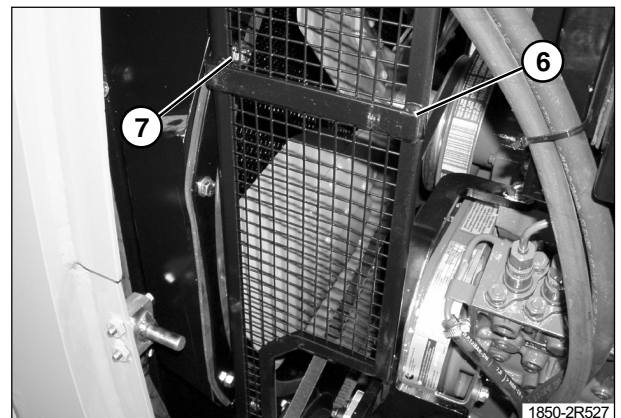

DTC (HEX)	Description	Dfp Name	DiaLamp	Power Red.
<p>ECU 2 1E3 1E4 1E9 1EA 1EB 1E5 1E6 1E7 1E8 1E1 2E1</p>	<p>(Powerst./Immobil./Overrun/Sensor supply) Overrun Monitoring failure Redundant Engine Speed in Overrun Monitoring ECU internal Supply Voltage too high ECU internal Supply Voltage too low Atmospheric Pressure Sensor failure Sensor 12V Supply Voltage failure Sensor Supply Voltage 1 failure Sensor Supply Voltage 2 failure Sensor Supply Voltage 3 failure High Side Power Stage Short to Ground or Battery Low Side Power Stage Short to Ground or Battery</p>	<p>OVRMon OVRMonSigA HWEMonUMaxSupply HWEMonUMinSupply APSCD SSpMon12V SSpMon1 SSpMon2 SSpMon3 StrtCDHS StrtCDLS</p>	<p>"SysLamp BLINK" "SysLamp BLINK" "SysLamp BLINK" "SysLamp BLINK" "SysLamp ON" "SysLamp ON" "SysLamp ON" "SysLamp ON" "SysLamp ON" "SysLamp ON" "SysLamp ON"</p>	<p>yes (technical) yes (technical) yes (technical) yes (technical) yes (technical) yes (technical) yes (technical)</p>

NOTES:

Remove the oil deflector.

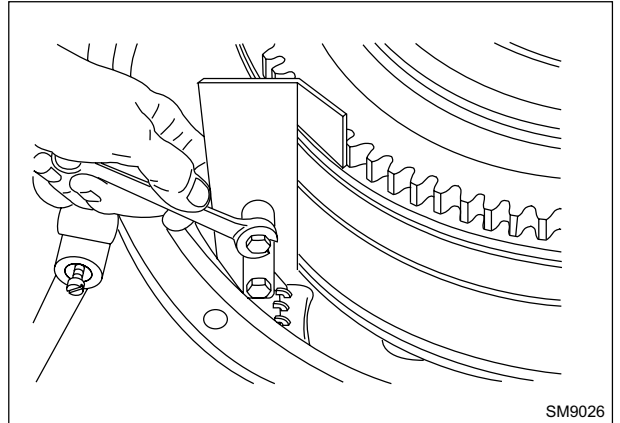

Remove the screws securing the equipment pump driven gear, lift the gear from the shaft nose and put it aside.

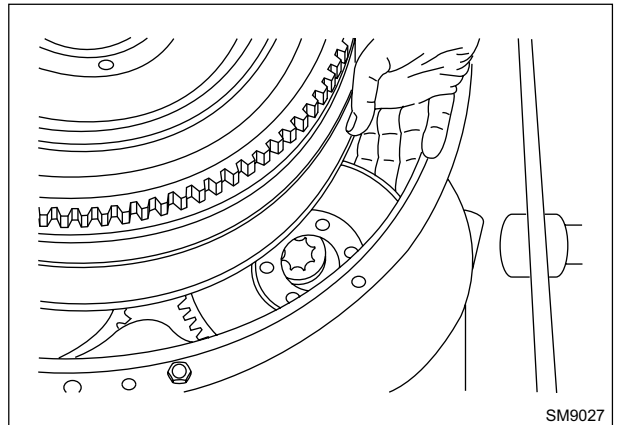

Secure a lifting chain to the torque converter; lift just enough to rotate the support so that the remaining gears are free, then pull the torque converter out the housing.



WARNING

**Lift and handle all heavy parts with a lifting device of appropriate capacity.
Make sure that the parts are secured by appropriate slings and hooks.**

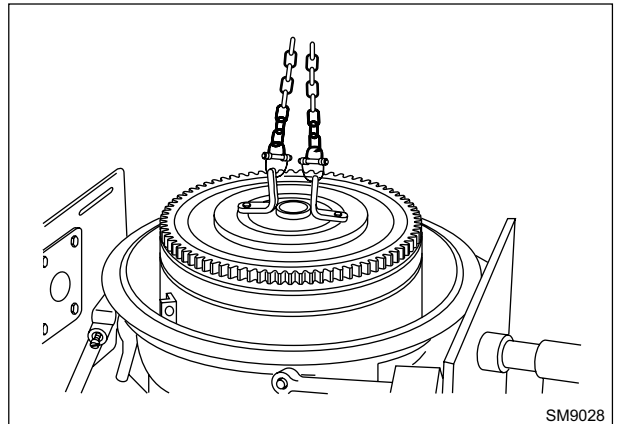

Pull the equipment pump driven gear out the housing.

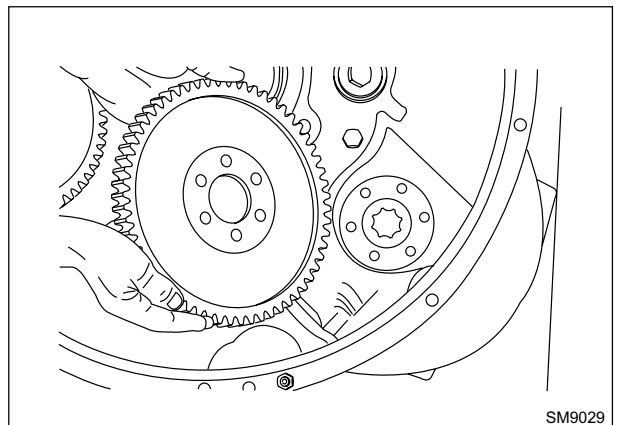

2.5.3 DISASSEMBLY

Place the transmission assembly on a rotary stand.



WARNING

Lift and handle all heavy parts with a lifting device of appropriate capacity.
Make sure that the parts are secured by appropriate slings and hooks.

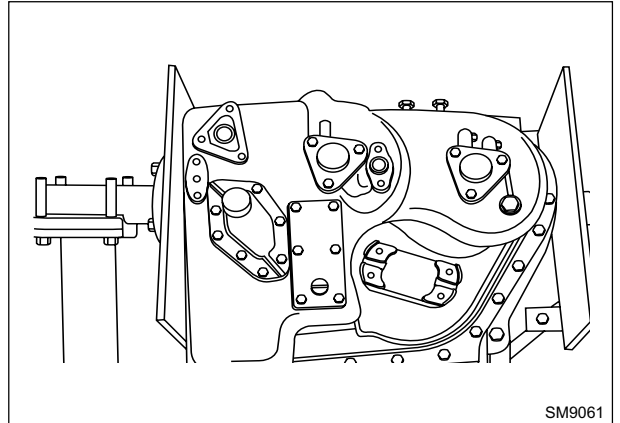

SM9061

Remove the lube manifold cover.

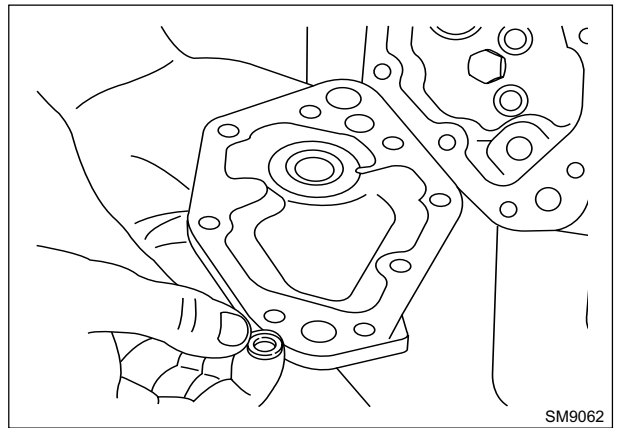

SM9062

Remove the modulating valves cover.

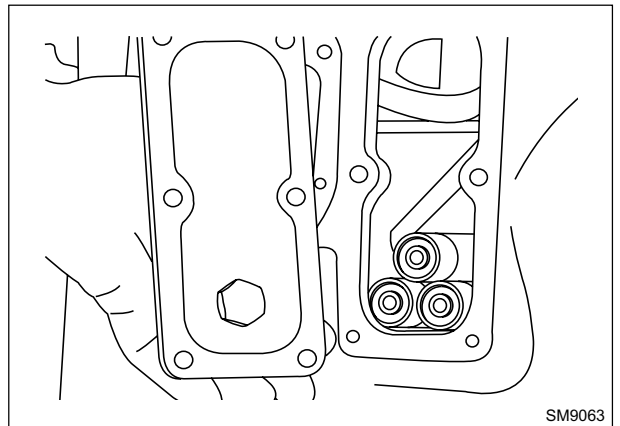

SM9063

Remove the modulating valves from the housing.

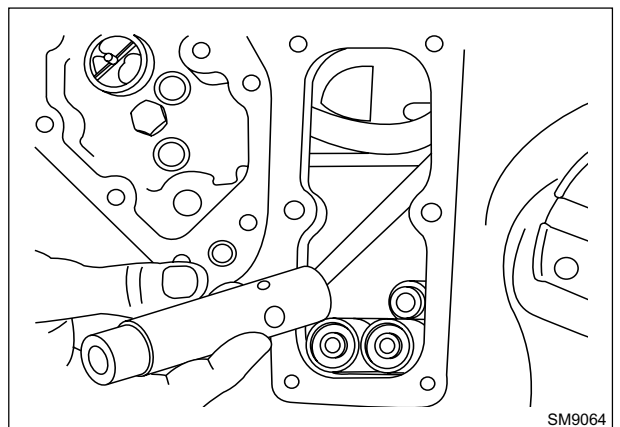

SM9064

Remove the medium range clutch assembly.

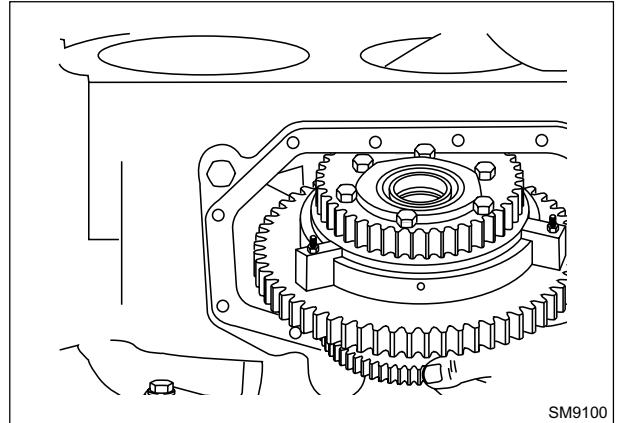

To pull-out the medium range clutch drum bearing, use an appropriate punch, after removing the two screws with retaining nut.

⚠ WARNING

It is dangerous hitting hardened steel parts with tools different from hammers made of mild steel or non ferrous metals. When these components are remove or installed, always wear safety glasses with side shields, heavy gloves etc., to reduce the chances of injuries.

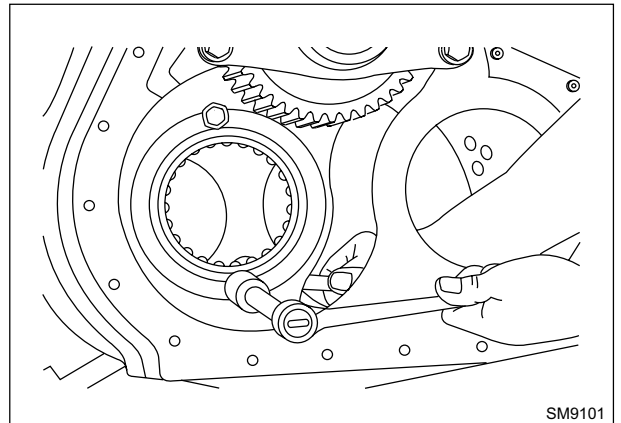

Remove the screws securing the input drive gear seal and the bearing support, then extract the shaft prying it.

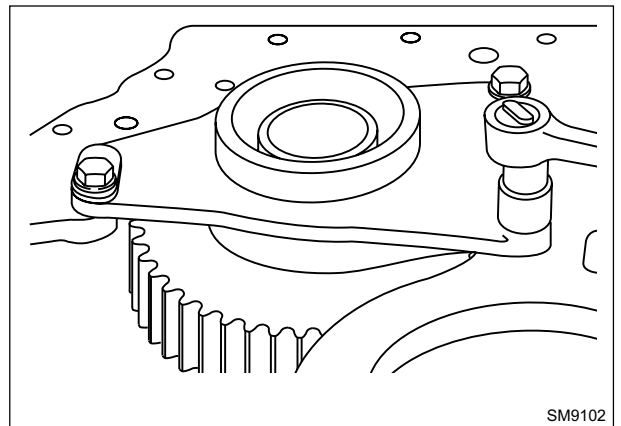

Remove the input drive gear using a pry bar and hammering the shaft.

⚠ WARNING

It is dangerous hitting hardened steel parts with tools different from hammers made of mild steel or non ferrous metals. When these components are remove or installed, always wear safety glasses with side shields, heavy gloves etc., to reduce the chances of injuries.

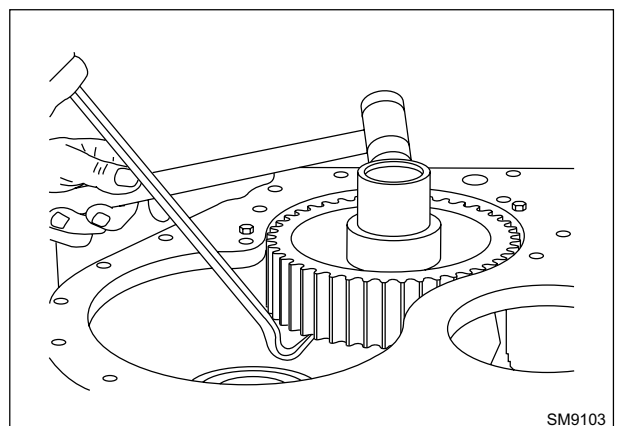

Install the central hub assembly and clutch pack on the high range clutch drum.

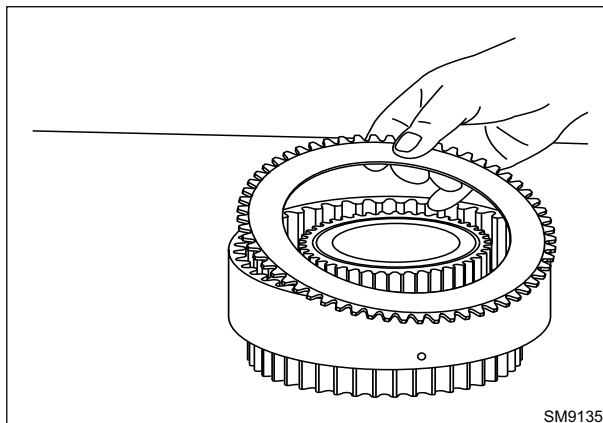

Install the alignment tool (P/N 380001347) in the hub grooves.

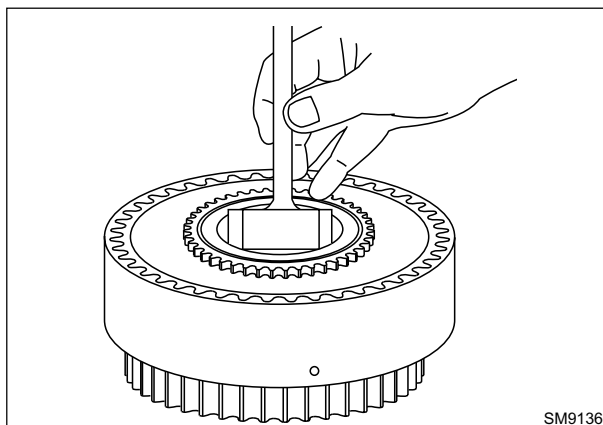

Arrange the gear assembly on the hub assembly and align the relevant grooves with the grooves on the hub.

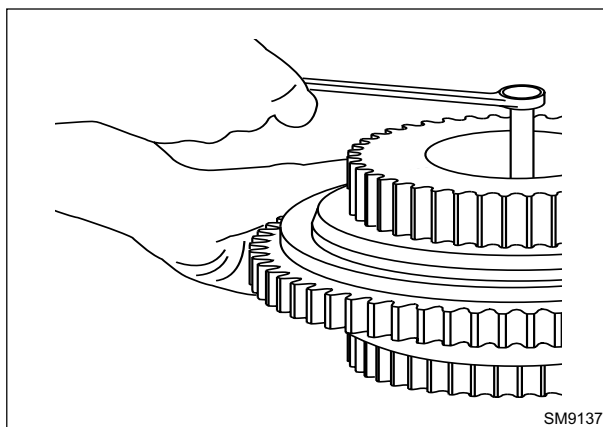

Check the alignment of the grooves using the high range shaft, prior to introducing the high range clutch assembly into the transmission housing.

Note – *It is important that the grooves are perfectly aligned, otherwise they could be damaged during the installation of the shaft.*

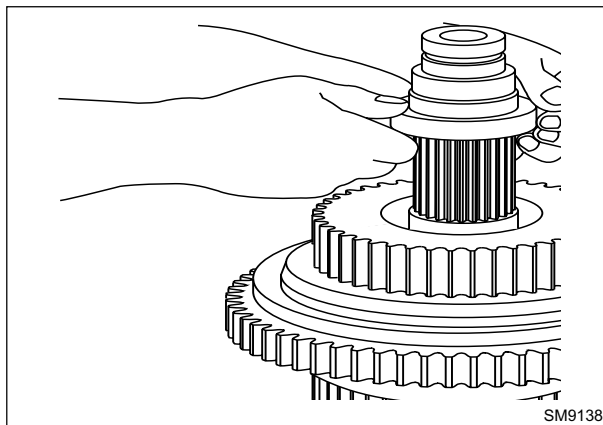

2.6.2 TIGHTENING TORQUES (TORQUE CONVERTER)

DESCRIPTION	daNm (*)	lbf.ft
1. Securing screws, front bearing stop	From 4.1 to 4.9	From 30.2 to 36.1
2. Securing screws, shaft hub stop	From 4.1 to 4.9	From 30.2 to 36.1
3. Securing screws, drive shaft	From 10.8 to 11.7	From 79.6 to 86.2
4. Securing screws, torque conv. housing	From 6.8 to 7.4	From 50.1 to 54.5
5. Securing screws, rear wheel	From 2.3 to 2.8	From 16.9 to 20.6
6. Securing screws, stator	From 3.4 to 3.9	From 25 to 28.7
7. Securing screws, pump drive gear	From 4.1 to 4.9	From 30.2 to 36.1
8. Securing screws, steering-brakes pump	From 1.2 to 1.4	From 8.8 to 10.3
9. Securing screws, pressure relief valve	From 6.8 to 7.4	From 50.1 to 54.5
10. Securing screws, rear bearing support	From 8.0 to 8.8	From 59 to 64.9
11. Securing screws, rear output flange stop	From 4.1 to 4.9	From 30.2 to 36.1
12. Securing screws, oil deflector	From 3.0 to 3.3	From 22.1 to 24.3
13. Securing screws, oil deflector support	From 6.8 to 7.4	From 50.1 to 54.5
Screws, equipm. pump driven gear	From 7.5 to 8.3	From 55.3 to 61.2
Sec. screws, trans./torque conv. pump	From 6.8 to 7.4	From 50.1 to 54.5
Nut, pump drive hub	From 2.1 to 2.3	From 15.5 to 17
Secur. screws, hydraulic pump		

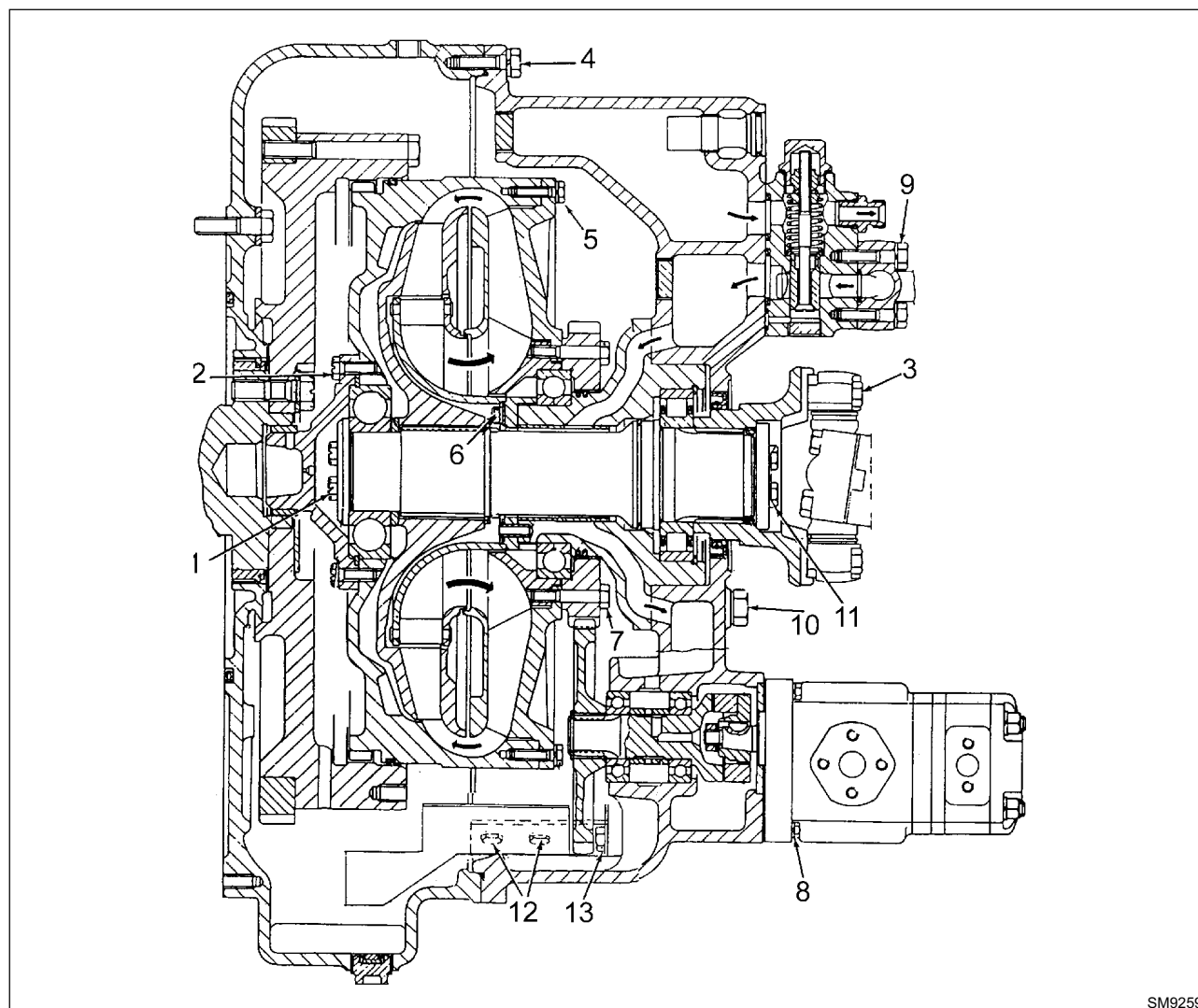

SM9259

Fig. 2-6 Section view of torque converter housing

2.7 SPECIAL TOOLS

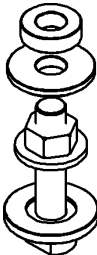
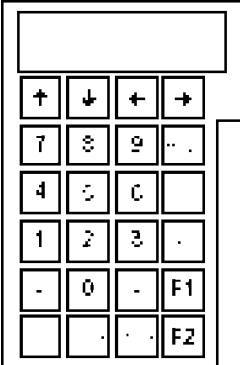
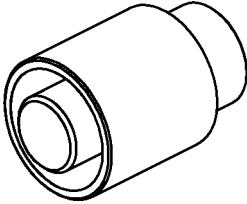
<p>38000972</p>		<p>Clutch spring pack compression</p>
<p>380001303</p>		<p>BB3</p>
<p>380001319</p>		<p>Tool, torque converter bearing installation</p>
<p>380001346</p>		<p>Tools bearings high speed retainer</p>
<p>380001347</p>		<p>Tool, drum positioning</p>

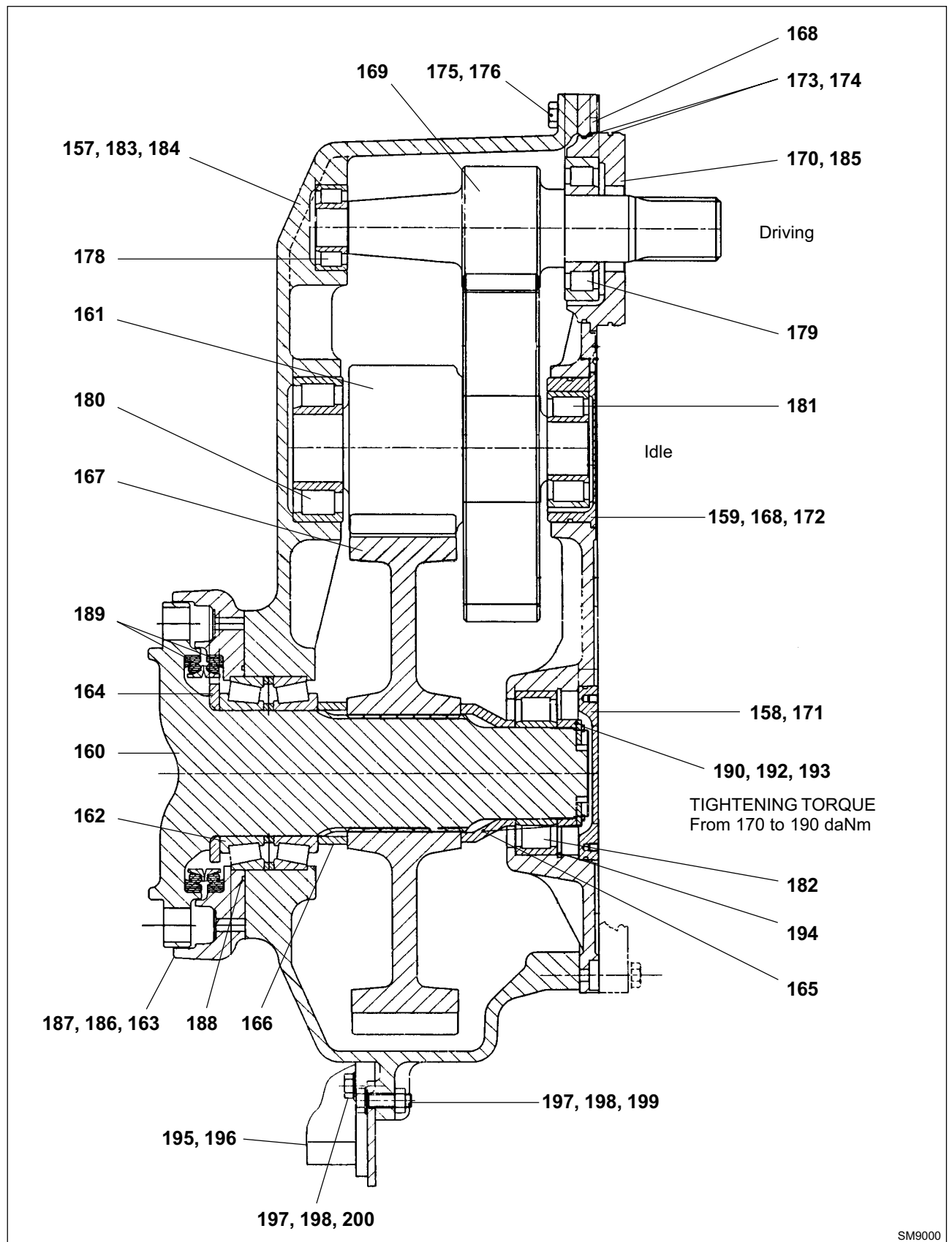
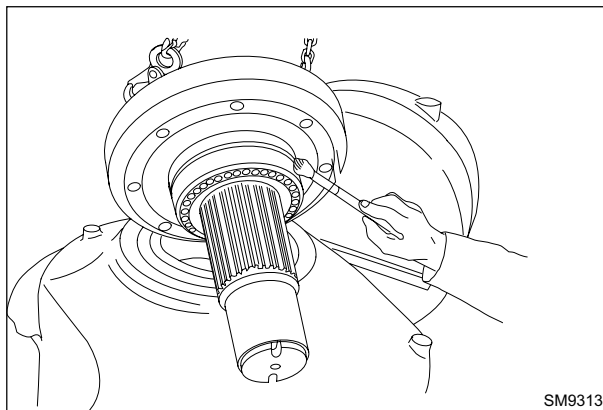

Fig. 3-3 Final drive sectional view (For the components, refer to fig. 3-2)

Lubricate adequately with oil or vaseline the contact surfaces of the sprocket shaft assembly.



SM9313

Fig. 3-31

Install O-Ring (188) in its seat.

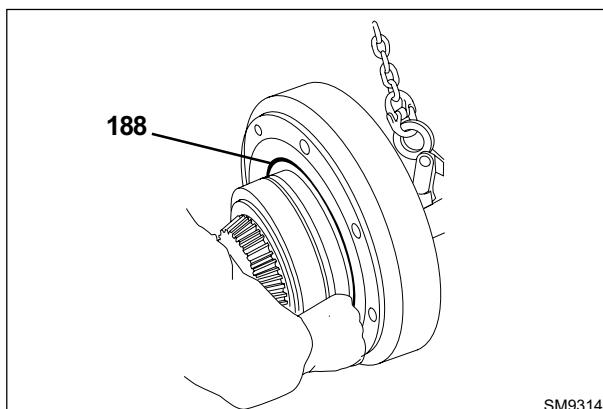

SM9314

Fig. 3-32

Install spacer (166) and insert the shaft into the housing, paying attention, during the centring phase, that the assembly sets-in in a uniform manner.

Install the 8 securing screws (M12x50) and tighten them to the prescribed torque (see Torque Tightening Table of **SECTION 0** at the beginning of this Manual).

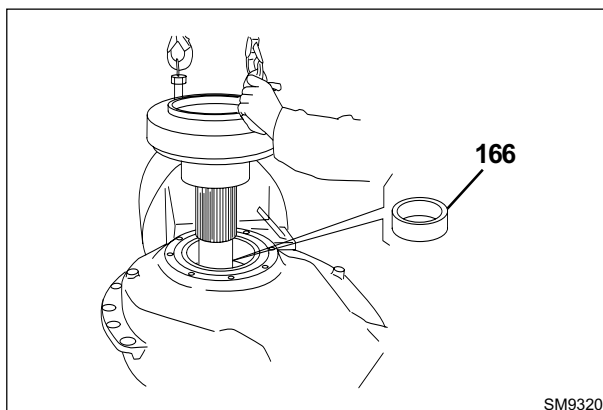

SM9320

Fig. 3-33

Turn the housing upside down and remove the driven gear retaining tool.

Install spacer (165) on the shaft.

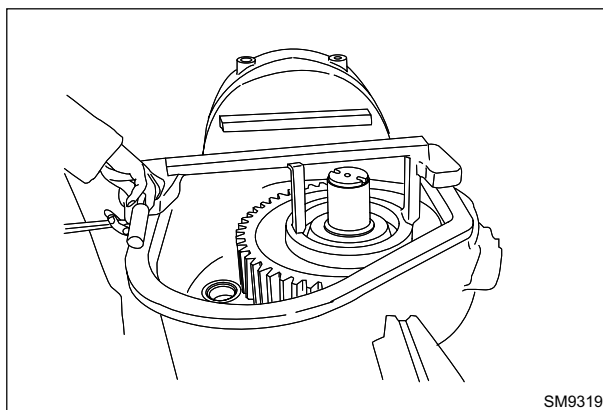

SM9319

Fig. 3-34

3.4 SPECIAL TOOLS

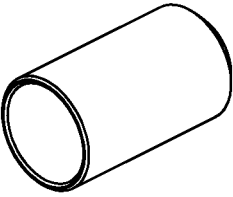
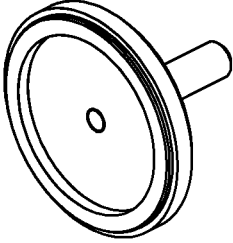
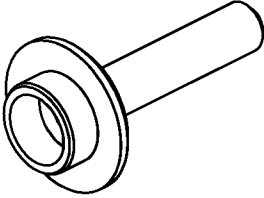
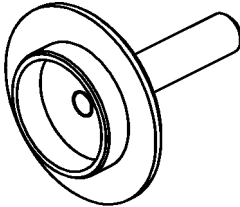
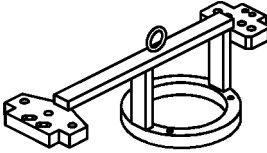
380001317		Tool, reduction unit pinion bearing installation
380001320		Installation of reduction unit housing seal
380001321		Tool, reduction unit housing bearing installation
380001323		Installation of reduction unit housing seal
380001349		Tool, reduction gear holding

4.1.3 STEERING CIRCUIT MAIN COMPONENTS

Note ñ For the following components.

- Variable displacement piston pump (ref. **P**)
 - Control valve (ref. **D**)
 - Powering valve block.
- Please refer to **SECT. 6 - EQUIPMENT HYDRAULIC SYSTEM DIAGRAM** page 6-5.

Hydraulic motor

Brand Rexroth

Type fixed displacement AZ FE 90/61W

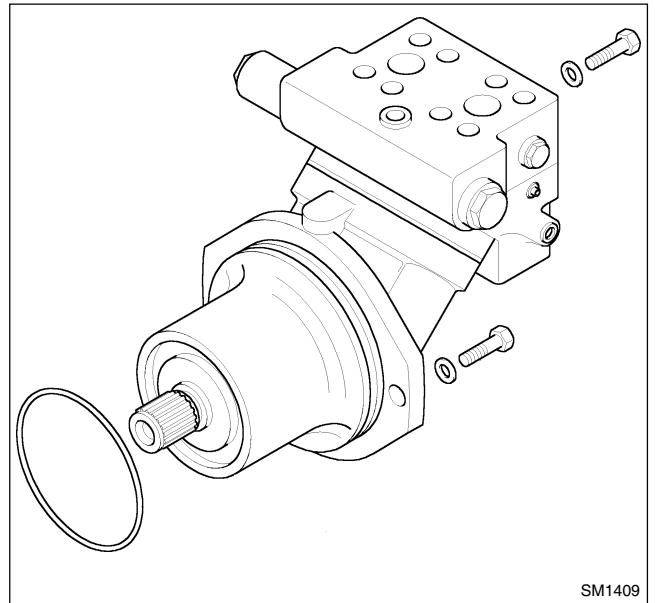

SM1409

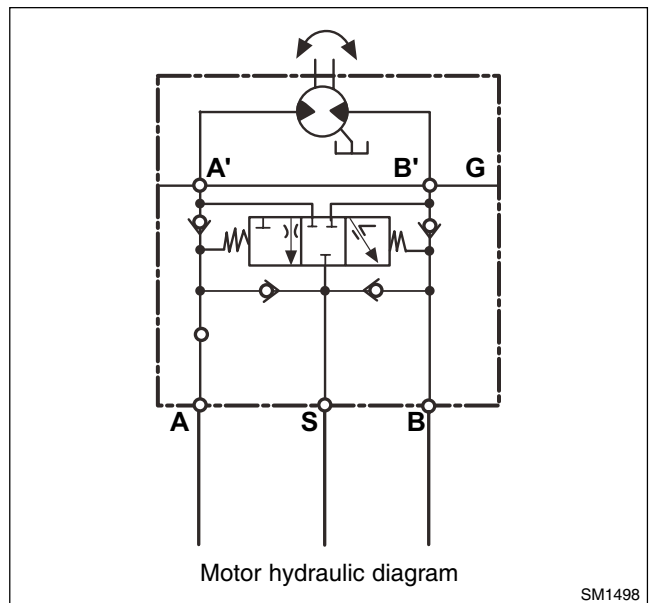

SM1498

- A.** To steering/equipment control valve
- B.** To steering/equipment control valve
- S.** To heat exchanger

NOTES:

Disassembly of the planet carrier differential assembly.

Lift the wings on the securing plates and remove the retaining screws from each pin.

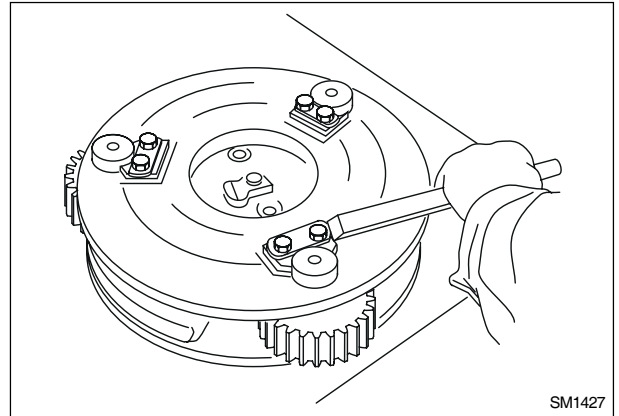

Then, pull-out the pins and all the components of the planet carrier assembly.

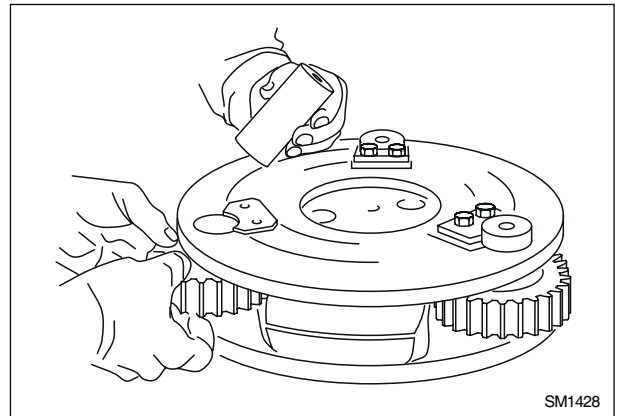

Exploded view of planet carrier assembly.

1. Planet carrier
2. Pin - q.ty 3
3. Planetary gear - q.ty 3
4. Needles - q.ty 29
5. Thrust washer - q.ty 2
6. Pin securing plate - q.ty 3
7. Safety plate - q.ty 3

Clean and wash accurately all components.



WARNING

Never use gasoline, solvents or any other flammable fluid to clean components. Use approved commercial non flammable and non toxic solvents only.

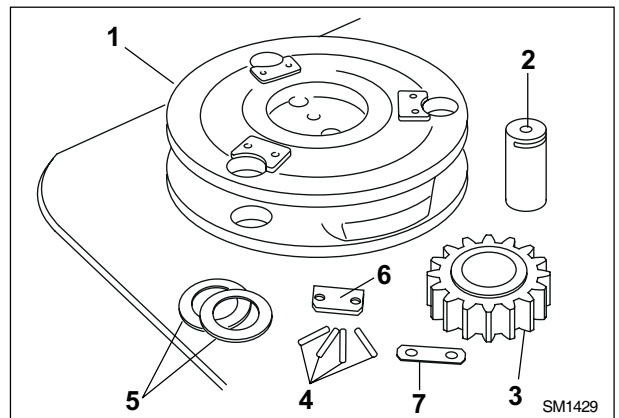

Disassembly of the sun gear

Pull-out the spacer from the drum of the brake assembly.

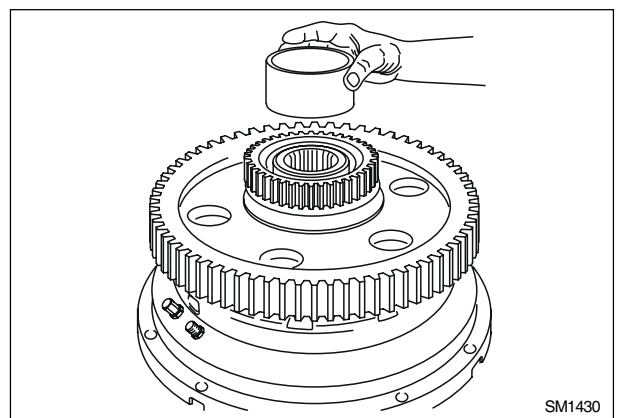

Install a hydraulic pump complete with connection, ensuring at least 30 to 40 bar (435 to 580.2 psi), at the power hole. Actuate the pump, up to a pressure of 20 to 25 bar (290 to 362.6 psi), so that the inner spring pressure is overcome to allow the discs to move to the bottom.

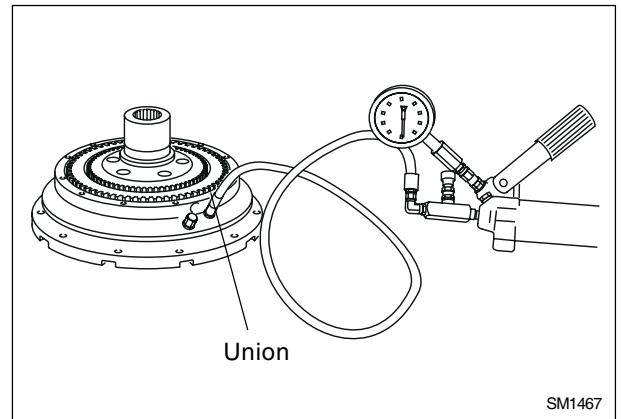

While keeping the piston under pressure, install the thrust disc on the drum. Then, tighten the 12 screws complete with washer and tighten to 11 daNm (81.1 lbf.ft).

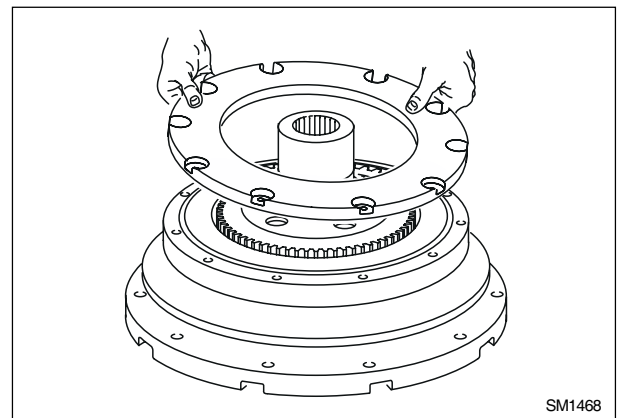

Install a puller to remove the bearing housing from the bevel gear shaft until it gets out from the taper spline, complete with seat.
Repeat the operation on the other side of the housing.

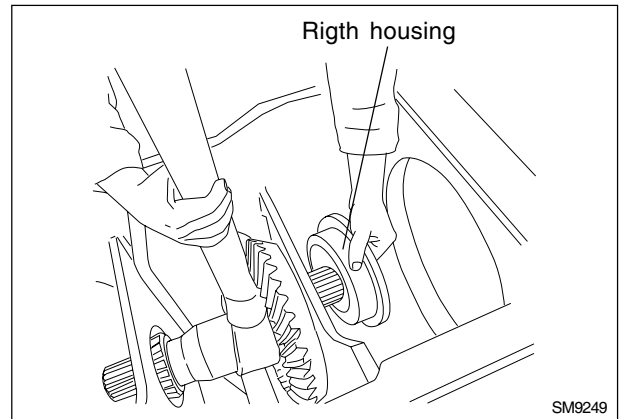

Remove the shaft complete with bevel gear, lifting it as indicated in the figure.

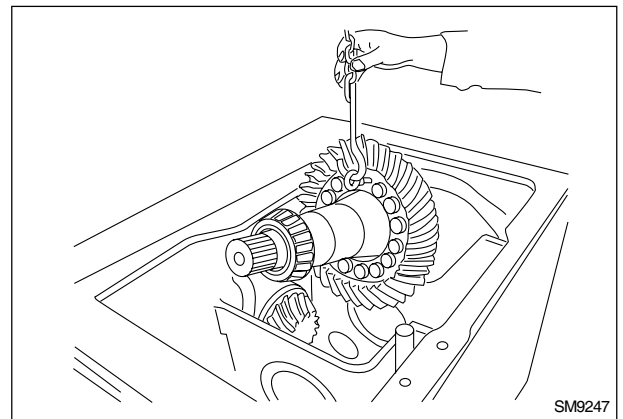

Disassembly of pinion

Secure the pinion in the appropriate bracket **P/N 380000983** and place it on a vice.

Remove the cover using a screwdriver and pull-out the O-Ring.

Pull-out the pinion retaining ring-gear, using the appropriate special tool **380000919**, torque wrench and torque multiplier.

Use a bearing puller to remove the pinion from the bearings.

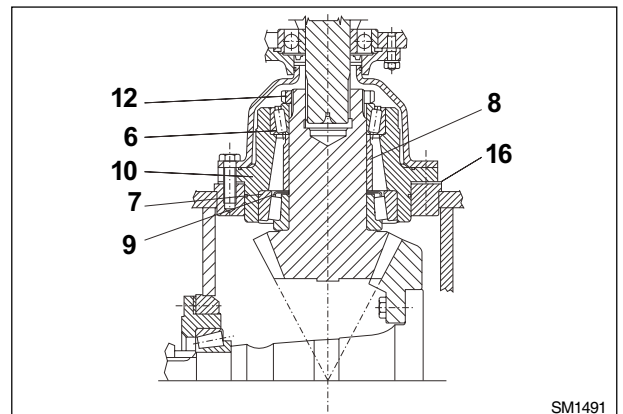
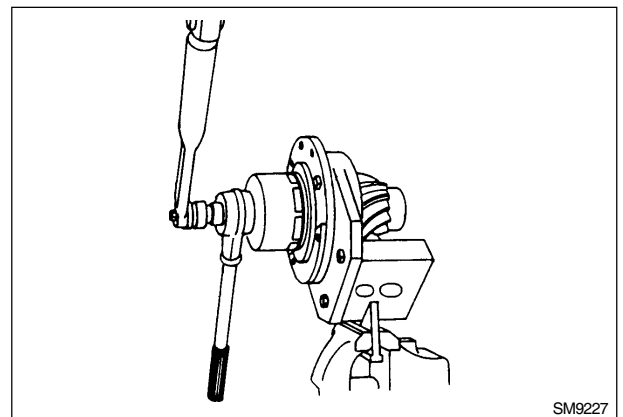

CLICK HERE TO **DOWNLOAD** THE COMPLETE MANUAL

- Thank you very much for reading the preview of the manual.
- You can download the complete manual from: www.heydownloads.com by clicking the link below



- Please note: If there is no response to CLICKING the link, please download this PDF first and then click on it.

CLICK HERE TO **DOWNLOAD** THE COMPLETE MANUAL

4.4.8 PROCEDURE FOR THE CHECK OF THE STEERING/EQUIPMENT PUMP PRESSURE

Open the panel on the right side of the cab. Remove plug (1) located on the pipe of feeling block (2) and install a 500 bar (7252 psi) scale pressure gauge.

Start the engine and let it warm-up for a few minutes at low idle.

Apply the pedal brake and shift into second or third speed.

Bring the engine to maximum speed.

Stall the steering by actuating the steering pilot valve and measure the pressure value on the pressure gauge that must be equivalent to 350 ± 5 bar (5076 ± 72.5 psi).

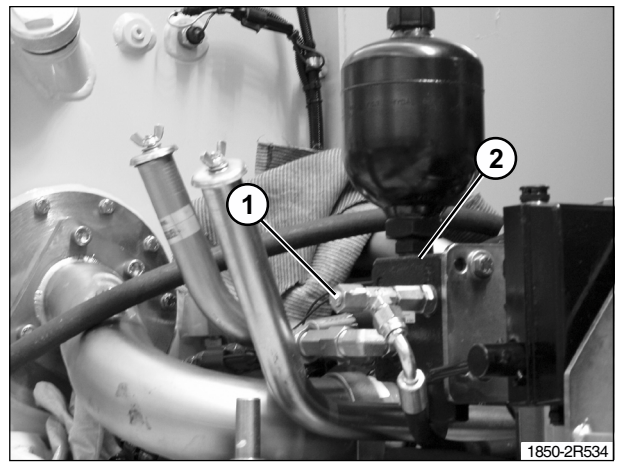

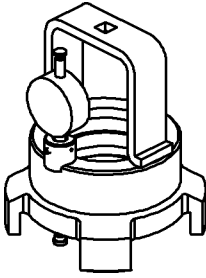
<p>380001483</p>		<p>Check caliper, bevel pinion bearings play</p>
<p>380001485</p>		<p>Support, steering differential bevel pinion on vice</p>

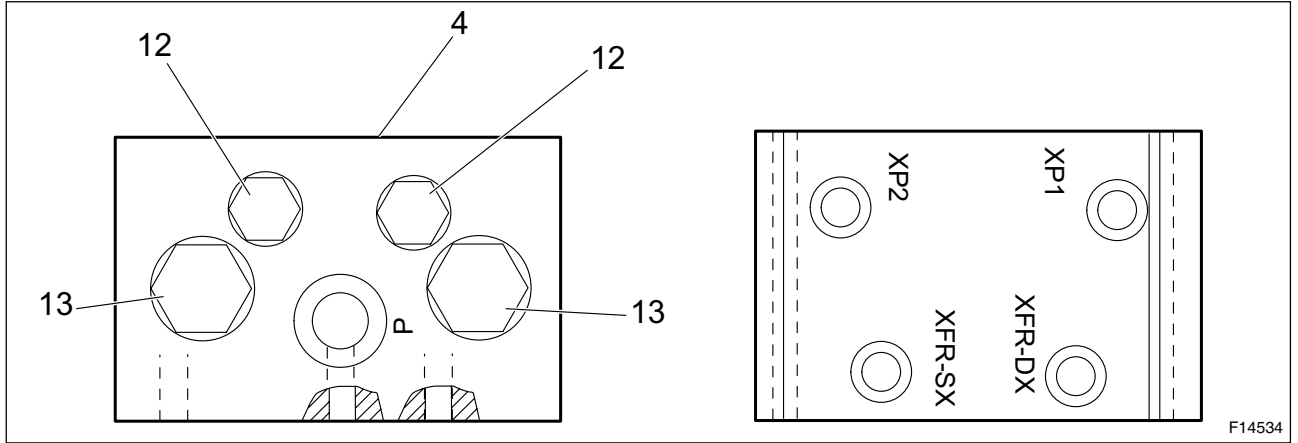

Front view

Rear view

- 4. Steering /brakes control valve
- 12. Decompression valve
- 13. Exchange valve
- P. Oil inlet from brake valve
- T. Discharge to housing

- XP1. Piloting pressure port P2
- XP2. Piloting pressure port P1
- XFR-DX. Right brake pressure pick-up point
- XFRN-SX. Left brake pressure pick-up point

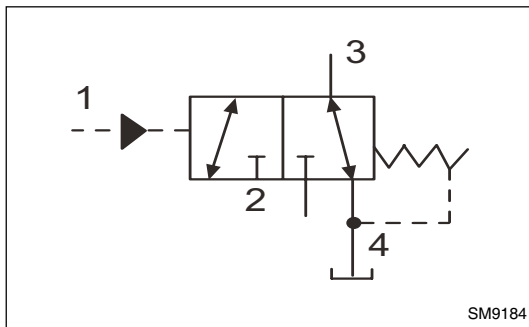

Decompression valve
(Ref. 12, hydraulic diagram)

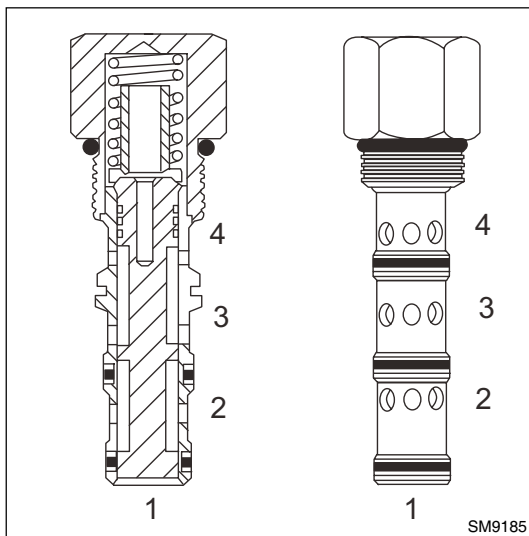

Section and view of control valve decompression valve ref. 12

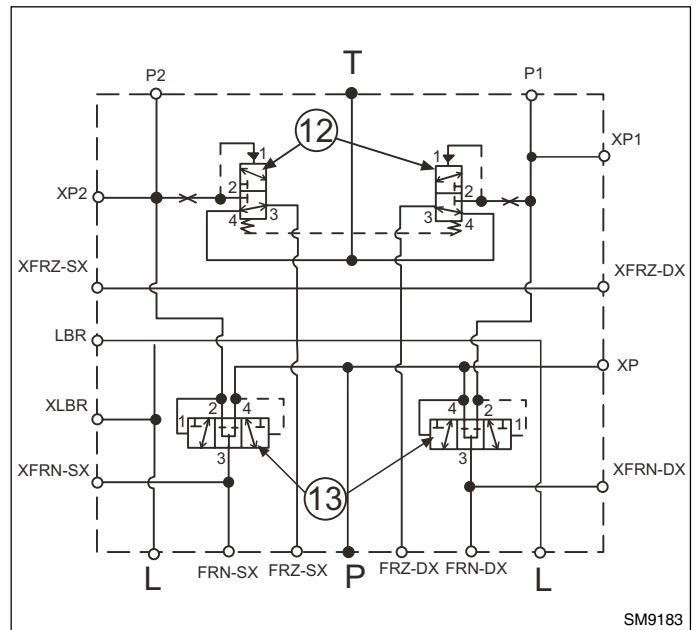

Control valve hydraulic diagram

Positioning of diagnostic hoses

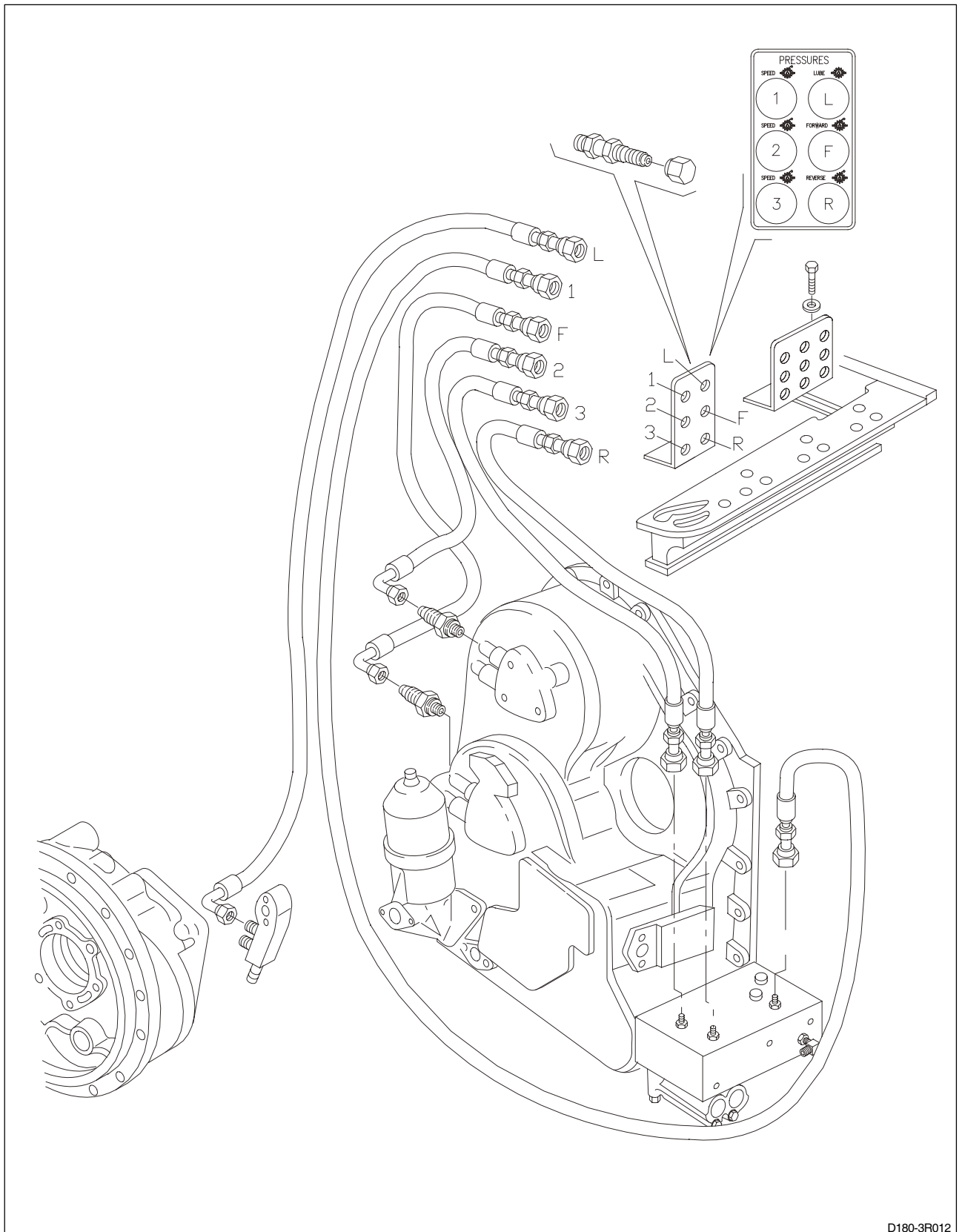

D180-3R012

4.4.2 STEERING CLUTCH AND BRAKE CONTROL FEEDING PUMP (Removal/Disassembly/Reassembly)

Removal

To remove the pump from the torque converter cover it is necessary:

- to tilt the cab and disconnect the pump (1) pipes;
- to remove the screws securing the front cover to converter housing (C) and remove the pump.

Disassembly

To disassemble the components of the pump, it is necessary to remove screws (1), remove the front and rear covers and extract supports (7) complete with gears (8 and 9).

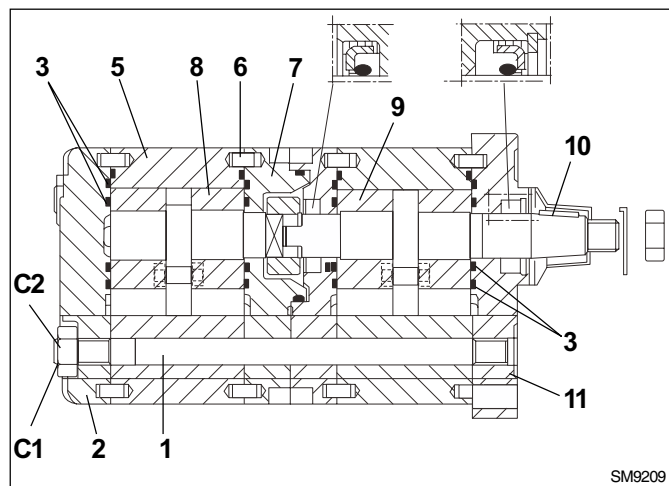

Steering clutch / brake feeding pump

1. Pump holding screw - 2. Rear cover - 3. O-Ring - 5. Pump body - 6. Dowel - 7. Supports - 8. and 9. Pump gears - 10. Key - 11. Front cover - 12. Centring ring - 13. Circlip - 14. Spring washer - 15. Drive ring locking nut - 16. Bushes - 17. Seal - 18. Circlip.
- C₁- Screw tightening torque 5 ÷ 10 Nm (3.69 to 7.38 lbf.ft)
- C₂- Nut tightening torque 44 ÷ 54 Nm (32.45 to 39.83 lbf.ft)

Inspection of components



WARNING

Never use gasoline, solvents or other flammable fluids to clean the components. Use approved commercial non flammable and non toxic solvents only.

Clean accurately all components and blow them with dry compressed air.

Check the pump gear support bushes; in the event they are scored, pitted or excessively worn, replace them. Check that pump body (5) in correspondence with the zone near the gears is not worn. Replace the parts if damaged. Replace all seals and gaskets.

Reassembly

Reassemble the pump reversing the sequence for the disassembly. Lubricate generously all inner parts and make sure that gears (8 and 9) turn freely, without hesitation.

Secure the pump to the torque converter cover, smearing the mating surfaces with an adequate sealing compound.

Connect the pipes.

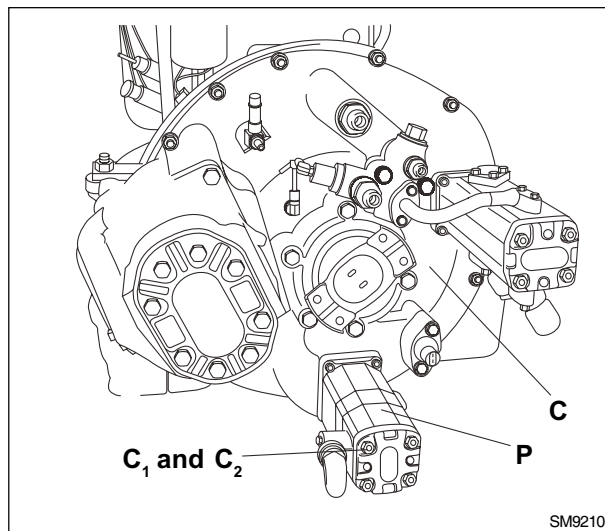

Torque converter cover

- C₁- Pump securing screw, tightening torque 5 ÷ 10 Nm (3.69 to 7.38 lbf.ft)
- C₂- Nut, tightening torque 44 ÷ 54 Nm (32.45 to 39.83 lbf.ft)
- P. Brake and steering clutch pump
- C. Torque converter.

4.4.5 BEVEL GEAR

Re-assembly / installation of bevel gear

Gear re-assembly

Install the gear on the shaft.

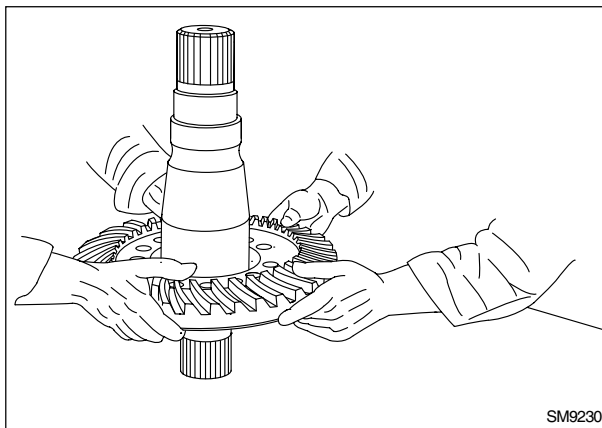

Tighten the gear on the shaft with the 16 self-locking screws. Please refer to the table of **SECTION 0 TABLE OF TIGHTENING TORQUES** for the tightening torques.

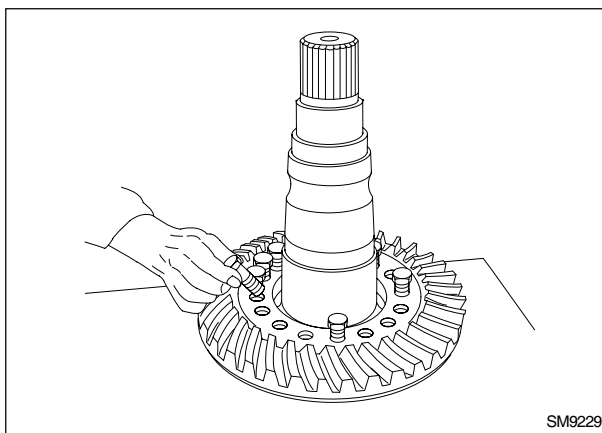

Warm-up the bearings at 110 °C (230 °F) and slide them individually on the shaft.

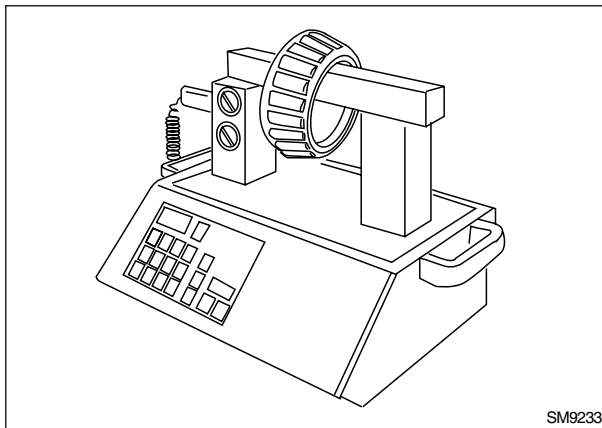

4.5.2 STEERING CLUTCHES

General data and dimensions	Ref.
TYPE	multiple disc, oil bath
Number of discs per clutch	
- Driven (with sintered facing)	Q.ty 7 98
- Driving (steel)	Q.ty 8 97
 Specification of springs	
Number of springs for each clutch	6 103
- Free length of spring	38 mm (1.496 in) 103
- Diameter of wire	$2 \pm 0,025$ mm (0.079 ± 0.00098 in) 103
- Outer diameter fully pressed	14 ± 0.1 mm (0.551 ± 0.004 in) 103
Load with compression at:	
- 33.5 mm (-1.318 in)	4.7 ± 0.2 daNm (34.665 ± 1.4751 lbf.ft) 103
- 29.5 mm (-1.161 in)	8.9 ± 0.4 daNm (65.643 ± 2.9502 lbf.ft) 103
 Matings and tolerances	
Thickness of clutch disc pack	$60 \div 62$ mm (2.362 to 2.441 in)
.....	(under a load of 300 ÷ 400 kg (661.5 to 882 lb))
Average travel of pressure plate	4.5 mm (0.177 in)
Total travel	9 mm (0.354 in)
Thickness of steel plates	$3.35 \div 3.65$ mm (0.132 to 0.144 in) 97
Thickness of sintered driven discs	$4.70 \div 4.80$ mm (0.185 to 0.189 in) 98
Clutch inner hub bearings	
- Inner diameter	$\varnothing 64.985 \div 65.000$ (2.5585 to 2.5590 in) 101
- Outer diameter	$\varnothing 119.985 \div 120.000$ (4.7238 to 4.7244 in) 101

BRAKES

General data and dimensions	Ref.
TYPE	multiple disc, oil bath
Number of discs per brake	
- Driven (with sintered facing)	5 98
- Driving (steel)	4 97
 Specification of springs	
Number of springs for each brake	20 118
- Free length of spring	83 mm (3.268 in) 118
- Diameter of wire	5.5 ± 0.05 mm (0.216 ± 0.002 in) 118
- Outer diameter fully pressed	30 ± 0.30 mm (1.181 ± 0.012 in) 118
Load with compression at:	
66 mm (2.6 in)	135 ± 7 daN (303.48 ± 15.74 lb) 118
61 mm (2.4 in)	174 ± 9 daN (391.15 ± 20.23 lb) 118
 Matings and tolerances	
Thickness of clutch disc pack	$36.5 \div 38.5$ mm (1.437 to 1.516 in)
.....	(under a load of 300 ÷ 400 kg (661.5 to 882 lb))
Average travel of pressure plate	4.5 mm (0.177 in)
Average wear	3.5 mm (0.138 in)
Total travel	8 mm (0.315 in)
Thickness of steel plates	$3.35 \div 3.65$ mm (0.132 to 0.144 in) 97
Thickness of sintered driven discs	$4.70 \div 4.80$ mm (0.185 to 0.189 in) 98
 Clutch inner hub bearings	
Inner diameter	$\varnothing 104.985 \div 105.000$ (4.1333 to 4.1338 in) 114
Outer diameter	$\varnothing 159.985 \div 160.000$ (6.2986 to 6.2992 in) 114

5.1 GENERAL DESCRIPTION

5.1.1 GENERALITIES

When evaluating the undercarriage conditions, it is appropriate to consider that an accurate inspection, a proper preventive maintenance and a correct operation of the machine, are the elements contributing most to extend the life of components. It is good practice to clean, lubricate, adjust and repair the undercarriage at regular intervals, not limited to quick and incomplete inspections.

To evaluate exactly the conditions of components, proceed with a systematic and thorough inspection. If the machine was subject to excessive stress, the track frames could be deformed. Excessive or strange wear patterns on the idlers, the roller edges and the sprocket segments could be caused by deformed track frames.

Also, it is important to consider the conditions under which a crawler machine is often compelled to operated.

TERRAIN

Obviously, it is not always possible to choose the terrain and the operating conditions, but it is necessary to consider the geological configuration and the gradients which could influence the wear type and speed the undercarriage shall be subject to.

Working uphill - It results in moving weights and loads towards the rear end of the machine. The wear on the rear bottom rollers and the forward motion side of the sprocket segments and bushes increases.

Working downhill - It results in moving weights and loads towards the side of the machine facing downhill. There is a higher wear of the components, such as flanges a link sides, working in this position.

Working sideways - The weight of the machines is bearing on the side located on the downhill side, with a wear of the flanges and other components guiding the track chain.

Working on a cat's back - It causes a concentration of the loads on the inner side of the components. It increases the wear of the inner side of rollers and idlers and the inner tip of the grousers.

Working into a ditch - It causes the concentration of loads on the outer flanges of rollers and the outer race of idlers.

The environment and the type of materials moved are the elements determining the life of undercarriage, since some materials are more abrasive than others. Also, the abrasive action is generally higher when they are. Under this point of view, the most common materials can be classified as follows:

Gravel and rocks	- intense breakage and wear
sand (in water)	- fast wear
wet sand	- packing and high wear
sand (dry)	- high wear
top soil (wet)	- moderate wear
clay (wet)	- light - moderate wear
clay (dry or slightly wet)	- slight wear
talcum	
gypsum	
coal	- very slight wear
phosphates	

**WARNING**

Wear welder personal protection equipment, such as mask or dark glasses, helmet, apron, shoes and heavy gloves, every time arc cutting or welding is performed. Always wear dark protective glasses near welding in progress. NEVER LOOK DIRECTLY AT THE ARC WITHOUT APPROPRIATE EYE PROTECTION.

4. Remove the damaged link (2).
5. Remove link (6) and pull-out the section from it remaining in bush (5).
6. For the re-installation, use a portable hydraulic press complete with the tooling illustrated in figure 15.
7. Install a master bush (9) on a new link (11) and secure it to the track chain.
8. Reinstall the second link (6) on the master bush.
9. Install the two master bush rings (10) on links (7 and 8) and complete the operation reinstalling pins (3 and 4).

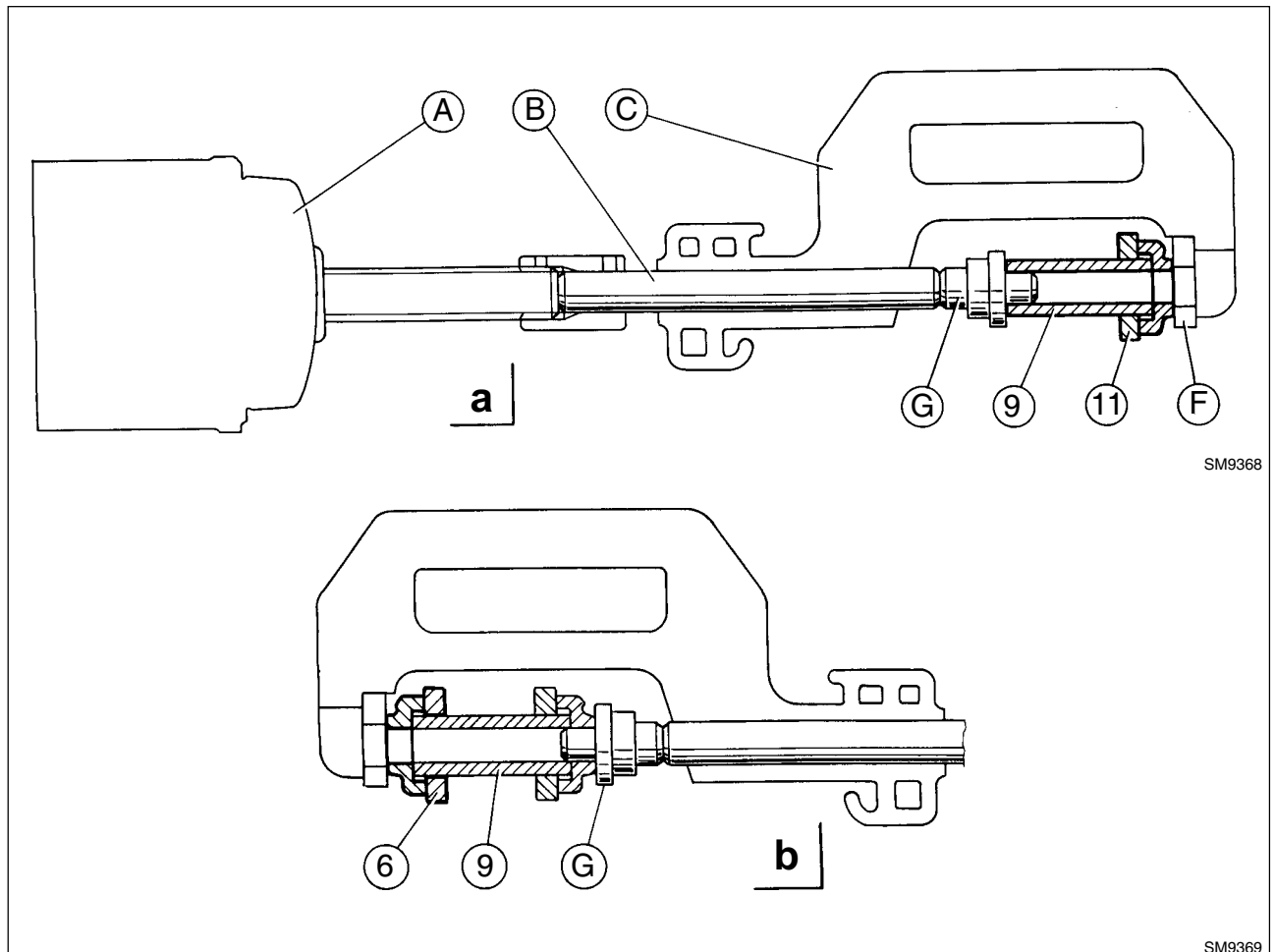

Fig. 5-15 Installation phases of bushes on the links of the track chain

a. Installation phase of the bush on the first link - **b.** Installation phase of the second link.

5.5 SPECIFICATIONS AND DATA

5.5.1 IDLER

Type permanently lubricated, equipped with metal (long-life) front seals.

Thickness of clearance adjusting shims (S_1) between end plates and idler guide pads: 0.5 mm (0.0197 in).

Thickness of clearance adjusting shims (S_2) between end idler support pads and track frame pads: 0.5 mm (0.0197 in).

Tightening torque

Bush housing self-locking securing screws (C_1) M10x1.5 (6.5 daNm) (47.94 lbf.ft)

Note ñ *Degrease and clean the front seal seats. Eliminate all traces of dust or imprints from the surfaces then cover them with a thin film of oil, making sure that the other surfaces remain dry.*

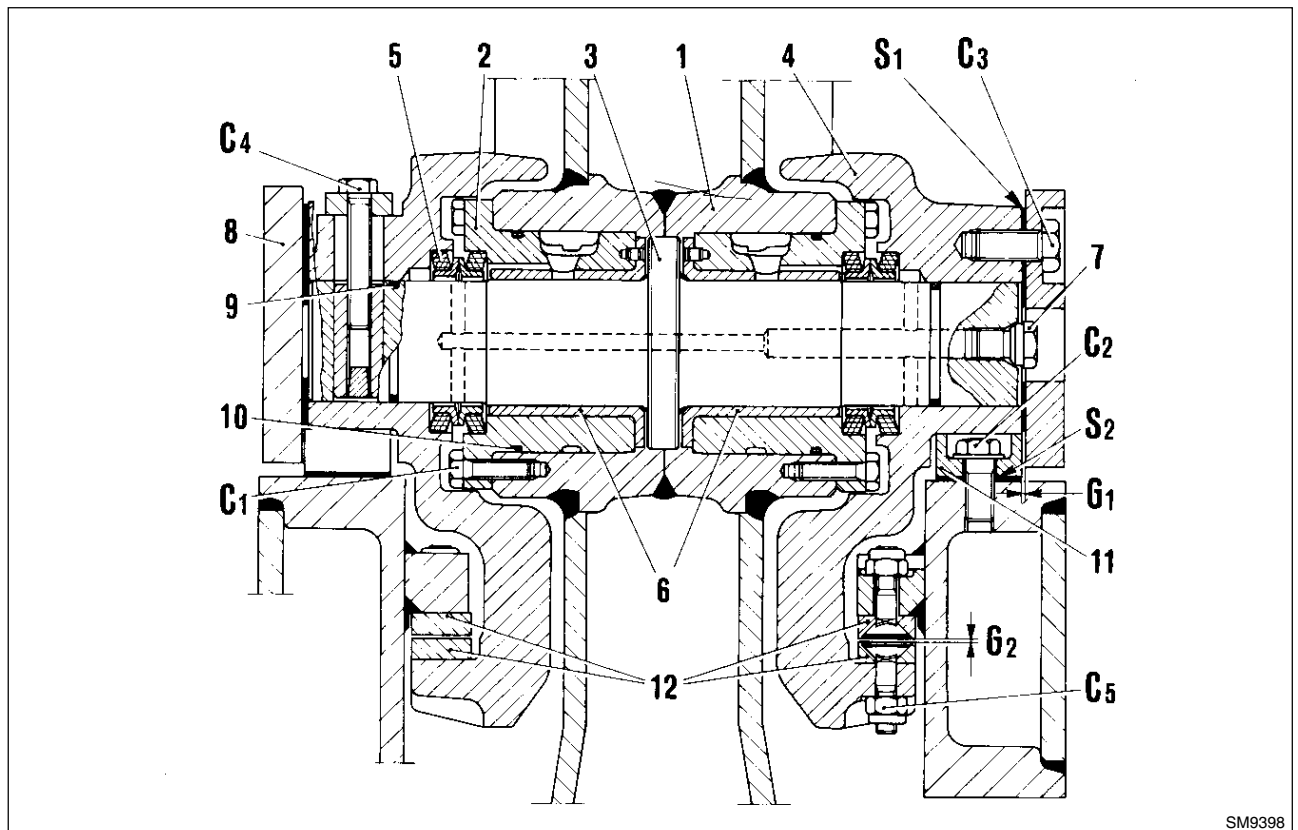

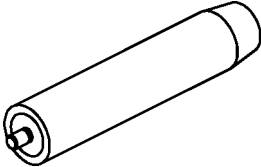
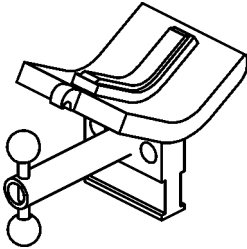
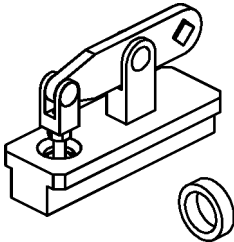
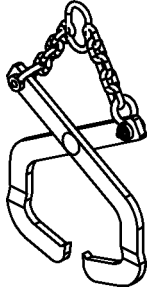

Fig. 5-48 Idler

C_1 . Bush housing self-locking securing screws - C_2 . Guide pad securing screws - C_3 . End plates self-locking securing screws - C_4 . Idler shaft locking screw - C_5 . Idler support pad securing nuts - $G_1 = 1$ mm. Clearance between end plates and guide pads $G_2 = 0.5 \div 1$ mm. Clearance between support pads and track frame - S_1 . Clearance (G_1) adjusting plates - S_2 Clearance (G_2) adjusting shims - 1. Idler - 2. Bush housing - 3. Idler shaft - 4. Idler support - 5. Front seal - 6. Shaft bushes - 7. Lube plug - 8. End plate - 9. and 10. O-Ring - 11. Guide pad - 12. Idler support pads.

5.6 SPECIAL TOOLS

380001316		Tool, removal/installation of track chain tension spring
380001308		Guide pin
380001309		Support, track rollers on vice
380001310		Tool, track chain pressure relief valve setting
380001311		Tool, wheel lifting

D180 TIER III COMMUNICATION STRUCTURE

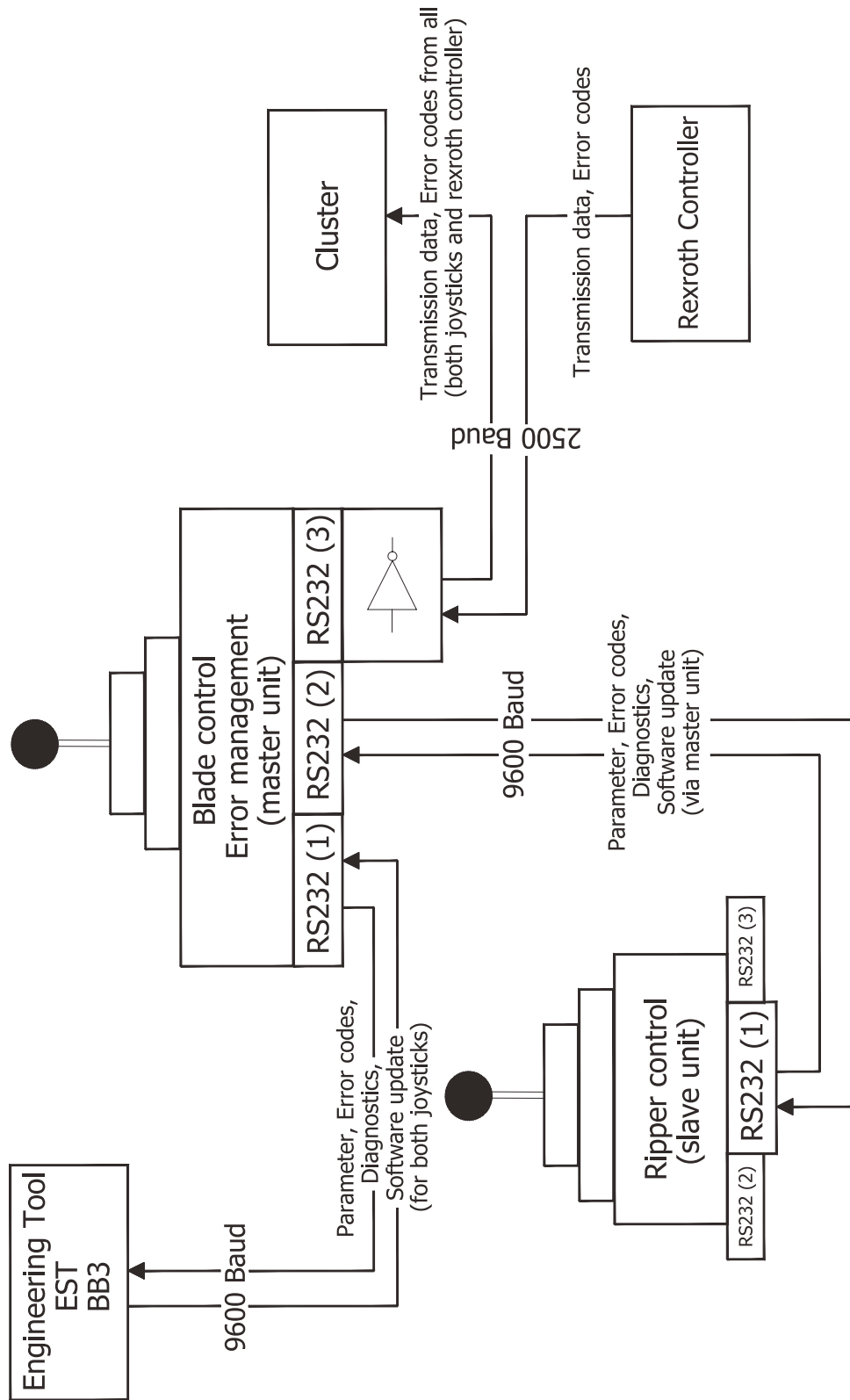

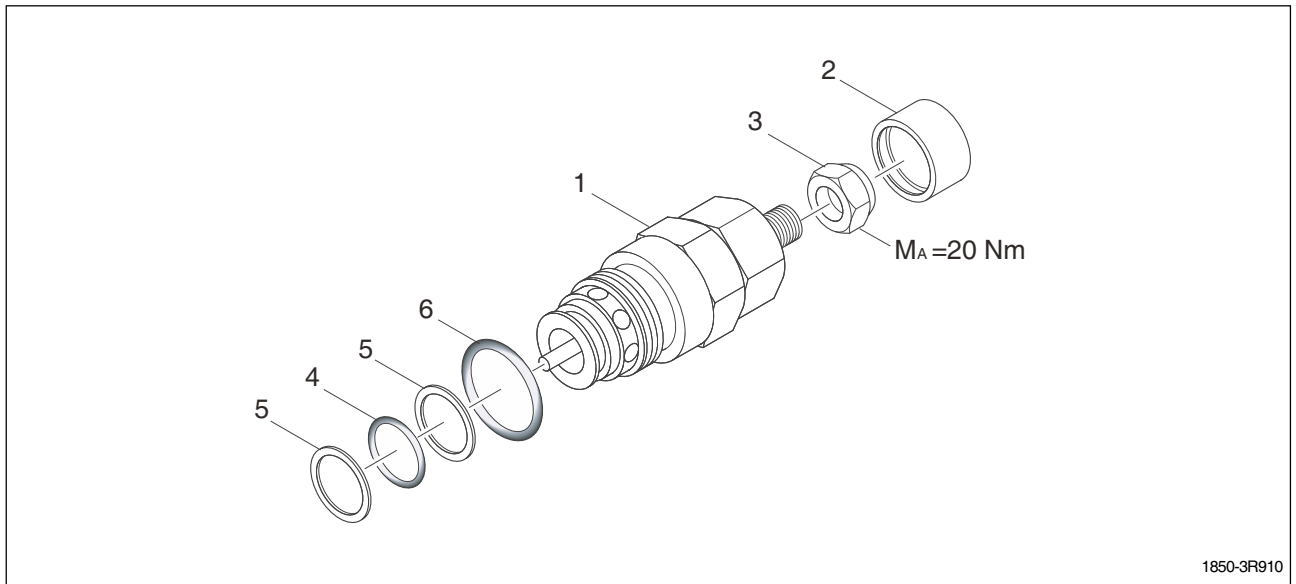
SAFETY VALVE (Item 4)

1. Body valve
2. Plug
3. Nut
4. O-ring
5. Ring retainer
6. O-ring

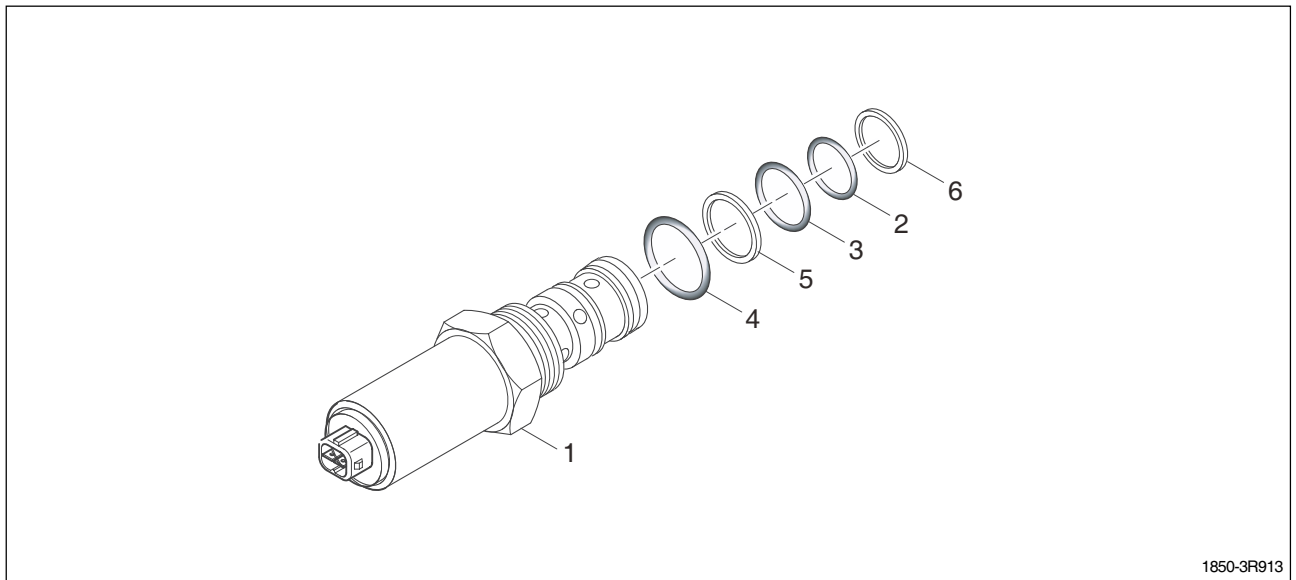
ELECTROVALVE (Item 5)

1. Body valve
2. O-ring
3. O-ring
4. O-ring
5. Ring retainer
6. Ring retainer

Install the shield over the hydraulic hoses on the tilt cylinder.



Connect bolt lift cylinders to the blade.

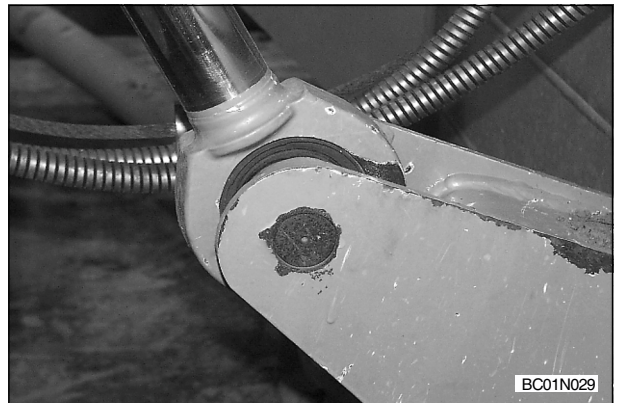

Install the retaining device on the pin and tighten the bolts.

Connect the stabilizer bars to the blade.



Connect the right stabilizer bar to the right push arm.



Using appropriate lifting chains hook in the appropriate eye (1) the first of the three Ripper shanks and position it into the relevant mounting seat.

Insert shank securing pin (2).

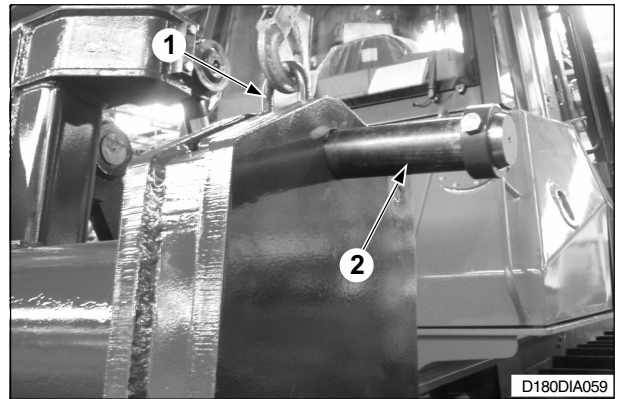

Insert on shank mounting pin (2) ring (3) screw (4) and secure the lot with nut (5) tightened to a torque of 110 Nm.

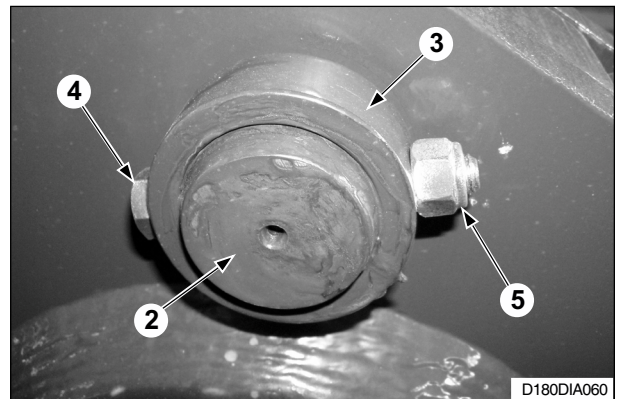

Install the second shank (6) and the third one (7) replicating the operations implemented during the preceding phases.

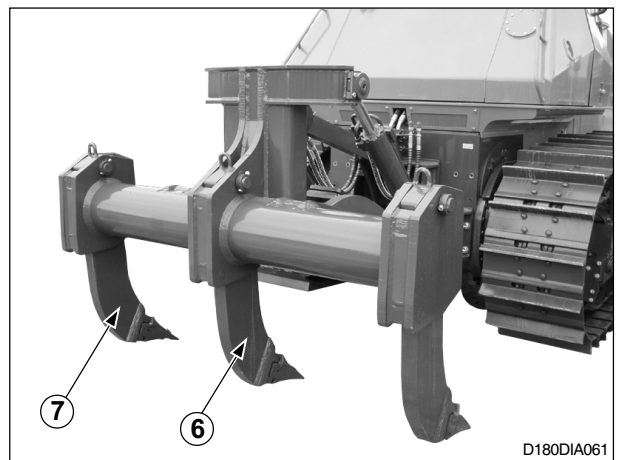

Check the level of the hydraulic oil through sight gauges (8) located on the tank. This inspection must be performed with the machine leveled, the attachment resting on the ground, cold oil and engine operating at low idle. Should the level be insufficient, remove cap filling (9) and top-up.

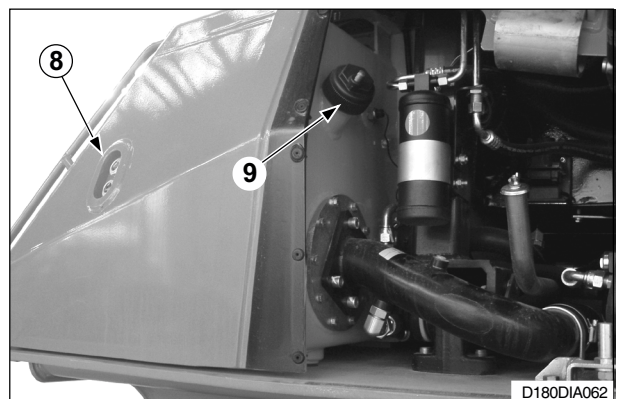

Connect the first of two hoses (1) on cylinder (2) using half brackets (3) screws (4) and the washers.

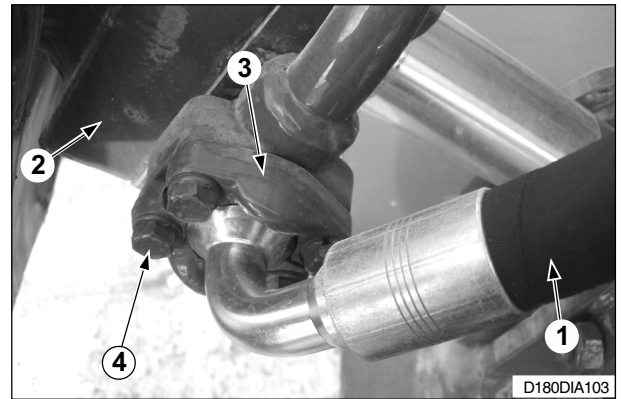

Connect the second hose (5) on cylinder (2) following the same procedure described in the previous operation.

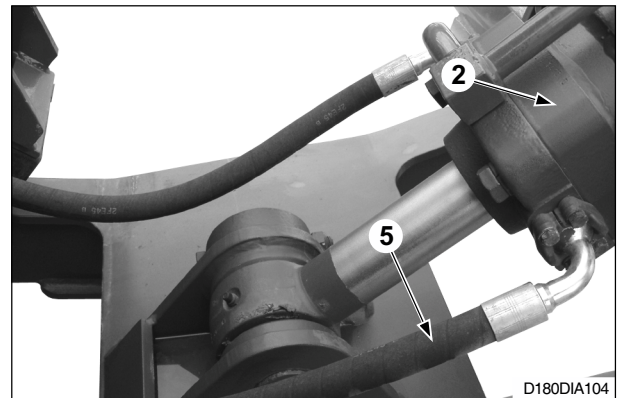

Use chains to sling the first of the three Ripper shanks by appropriate eye (6) and position it into the relevant mounting seat.

Insert pin (7) and two securing holders (8).

Install the other two shanks, following the same procedure.

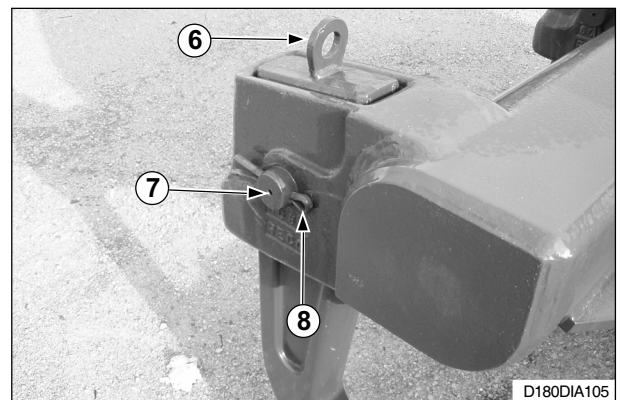

Check the level of the hydraulic oil through sight gauges (9) located on the tank. This inspection must be performed with the machine leveled, the attachment resting on the ground, cold oil and engine operating at low idle. Should the level be insufficient, remove cap filling (10) and top-up.

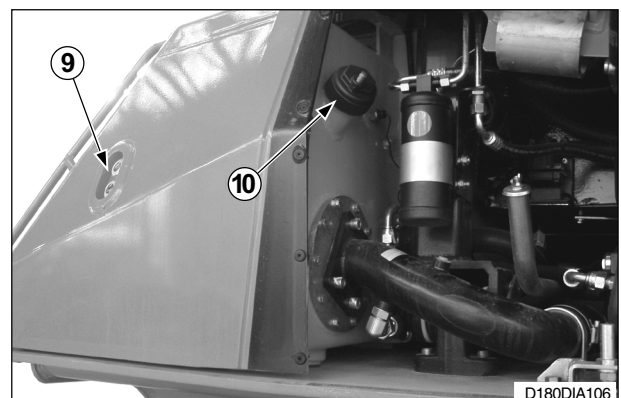

6.4.9 BLADE PUSH ARMS AND RODS

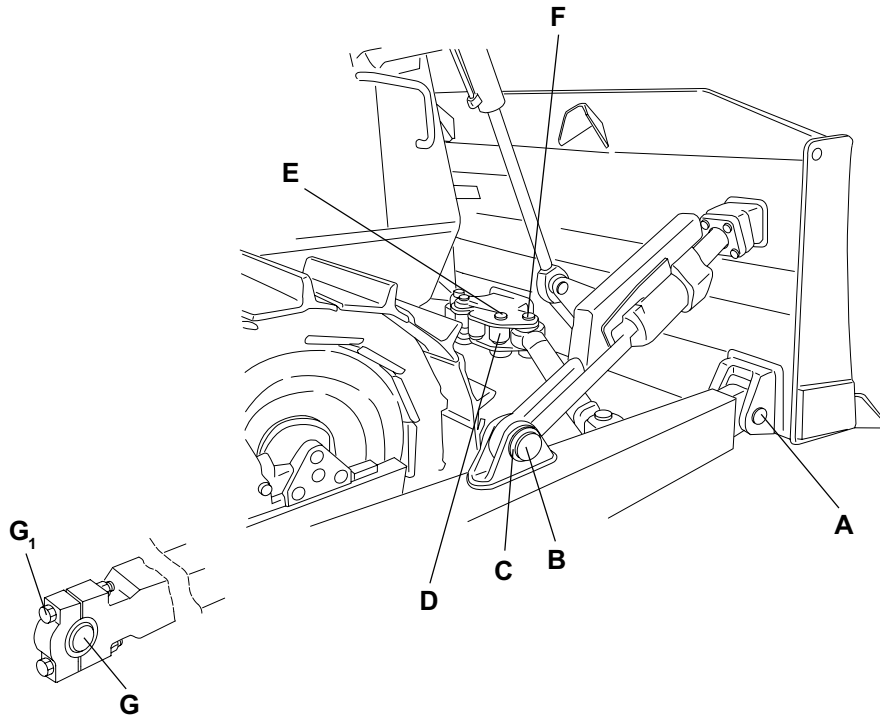

SM1606

Bulldozer equipment linkage

A.	Outer diameter of push arm front joint pin	59.954 to 60.000 mm (2.360 to 2.362 in)
	Inner diameter of ball joint	60.190 to 60.264 mm (2.369 to 2.372 in)
	Clearance	0.190 to 0.310 mm (0.007 to 0.012 in)
B.	Outer diameter of rear rod and tilt cylinder pin	69.954 to 70.000 mm (2.754 to 2.756 in)
	Inner diameter of pin bush	70.210 to 70.280 mm (2.764 to 2.767 in)
	Clearance	0.210 to 0.326 mm (0.008 to 0.013 in)
C.	Diameter of push on rod and tilt cylinder	81.875 to 81.929 mm (3.223 to 3.225 in)
	Outer diameter of bush	81.965 to 82.000 mm (3.227 to 3.228 in)
	Clearance	0.036 to 0.125 mm (0.001 to 0.005 in)
D.	Outer diameter of diagonal main rod and blade main pin	59.954 to 60.000 mm (2.360 to 2.362 in)
	Inner diameter of bushes	60.200 to 60.270 mm (2.370 to 2.373 in)
	Clearance	0.200 to 0.316 mm (0.008 to 0.012 in)
E.	Inner diameter of diagonal main rod and blade main pin	71.911 to 71.957 mm (2.831 to 2.833 in)
	Outer diameter of bushes	71.970 to 72.000 mm (2.834 to 2.835 in)
	Installation interference	0.013 to 0.089 mm (0.001 to 0.003 in)
F.	Outer diameter of front diagonal pin	59.954 to 60.000 mm (2.360 to 2.362 in)
	Inner diameter of ball joint	60.190 to 60.264 mm (2.369 to 2.372 in)
	Clearance	0.190 to 0.310 mm (0.007 to 0.012 in)
G.	Outer diameter of push arm joint pin	119.780 to 120.000 mm (4.715 to 4.724 in)
	Inner diameter of push arm rear pin bush (in its seat)	120.180 to 120.400 mm (4.731 to 4.740 in)
	Clearance	0.180 to 0.620 mm (0.007 to 0.024 in)

380060213 CE - EST KIT COMPLETE KEYBOARD version
380060167 CE - EST KIT COMPLETE TABLET version

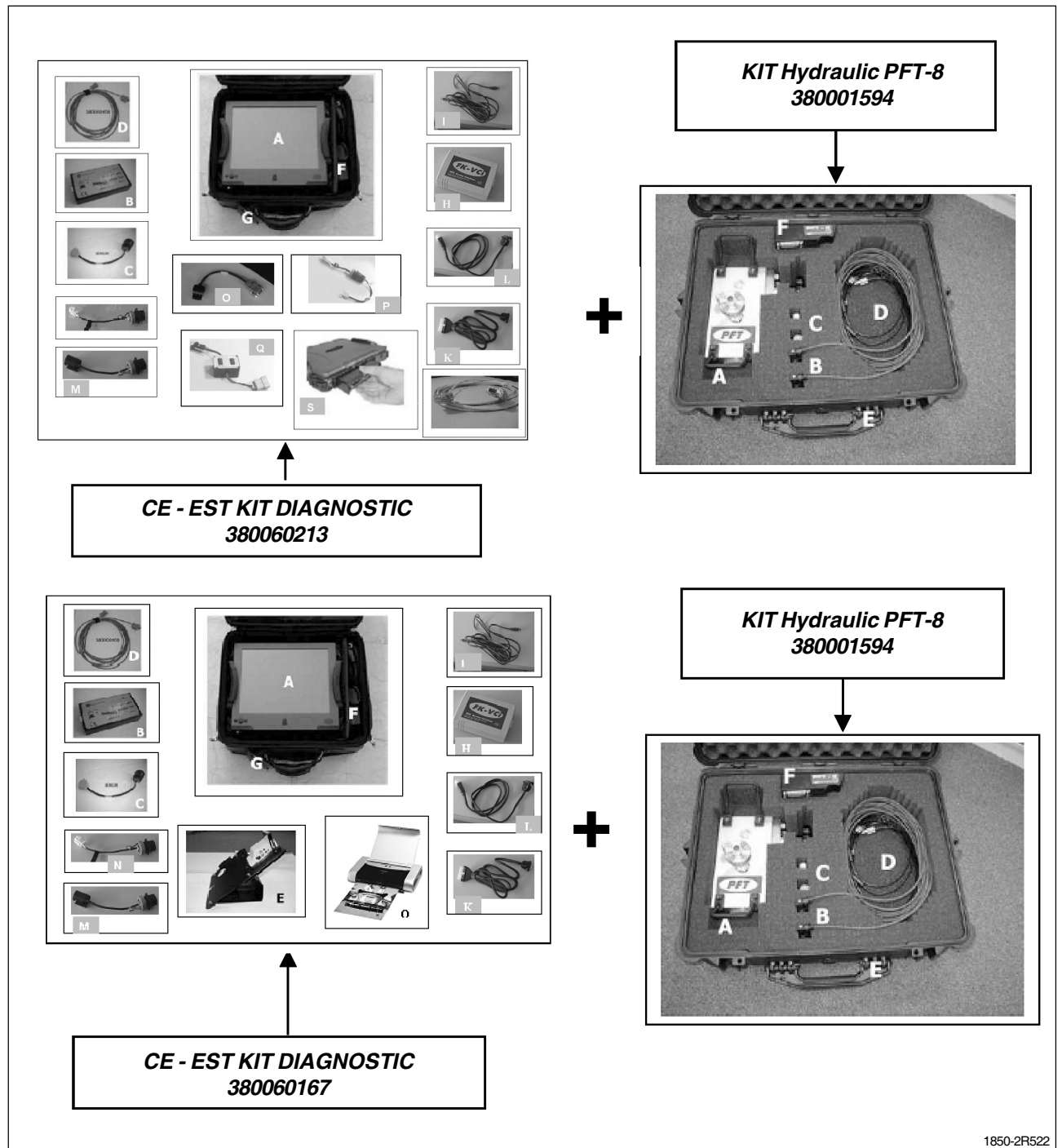

1850-2R522

TROUBLE	POSSIBLE CAUSE	TOOLS REQ.ED	TEST	SOLUTION
The equipment does not stay in the position chosen (continued)	Pump suction leaking		Check if there are traces of oil on the ground or the transmission	Repair the seal or tighten the connections
The blade does not maintain the pitch and tilt positions	Cylinder piston seal leaking		Perform flow test	If cylinder fails the test replace seal
	Excessive spools leakage		Perform flow test	If replacement of circuit safety valve is not sufficient, replace control valve
	Stroke-end valves stuck open		Perform flow test	Replace stroke-end valves
Equipment operation slow or weak	Suction filter clogged		Perform flow test	If suction is clogged, clean suction filter
	Main safety valve set too low		Perform flow test	Re-set at correct pressure
	Main pump defective		Perform flow test	Replace pump
	Main valve body broken		Perform flow test	If it fails test, replace valve
(blade only)	Quick drop valve plunger stuck open		Perform flow test	Clean or replace valve
Faulty operation of equipment	Oil level insufficient	Operation and Maintenance Instruction Manual		Refill equipment reservoir with oil of the prescribed type
	Suction filter clogged		Perform flow test	If suction is clogged clean suction filter
	Pump suction leaking		Check if there are traces of oil on ground or transmission	Replace seal or tighten connections

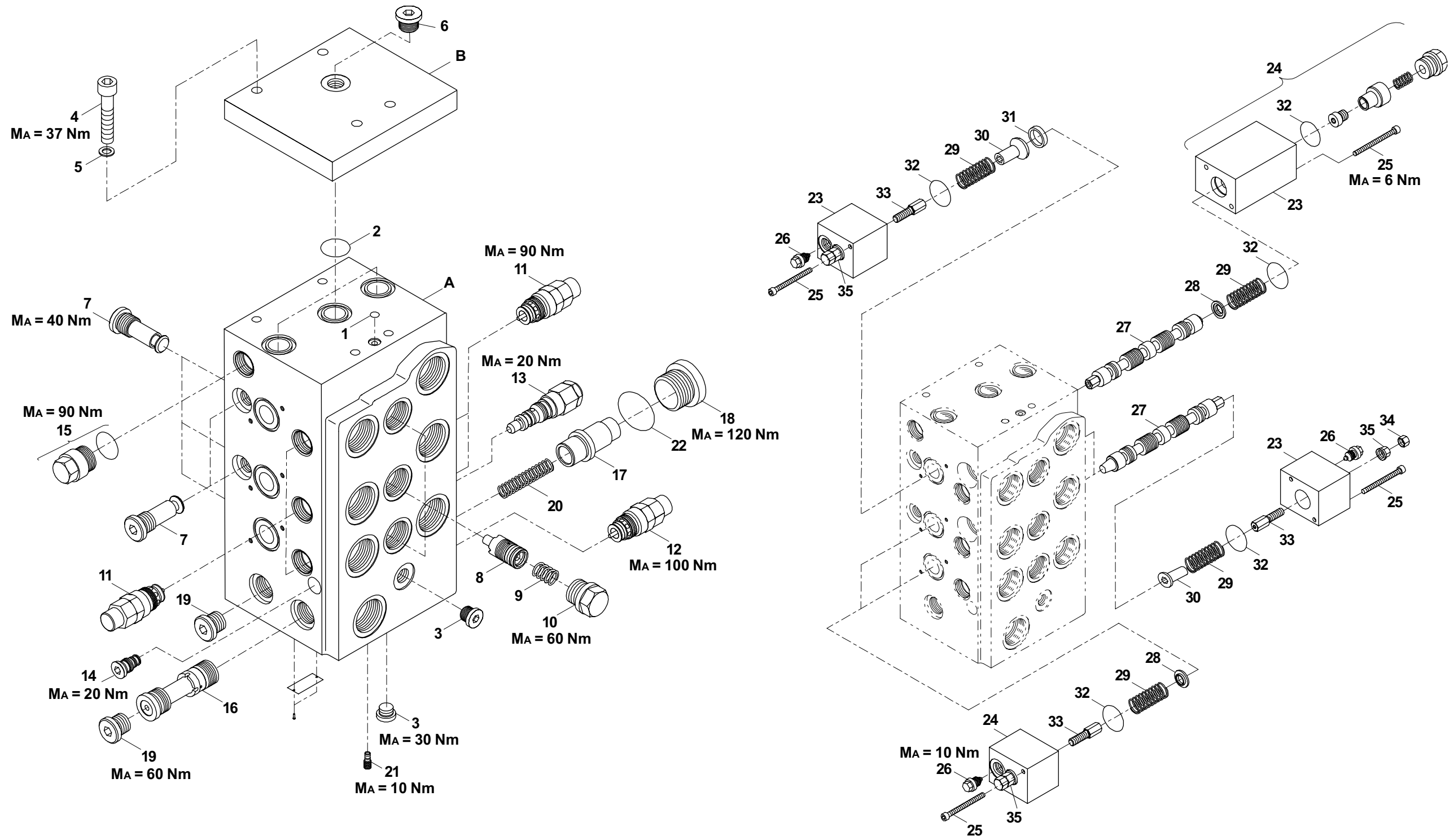

Fig.10 View hydraulic distributor components

6.5.10 RIPPER LINKAGE FOR LT/XLT MODEL

Model	PD 180
Type	parallelogram, actuated by two double stroke cylinders, equipped with semi curved teeth with interchangeable tips.
A. Max. work depth	540 mm (21.260 in)
B. Max. work width	1900 mm (74.803 in)
C. Max. tooth lifting	503 mm (19.803 in)
D. Nominal diameter of cylinder piston	100 mm (3.937 in)
E. Cylinder rod max. stroke	480 mm (18.898 in)
F. Diameter of bush seat in cylinder rod	78.000 ÷ 78.046 mm (3.0709 to 3.0727 in)
Outer diameter of bush	78.070 ÷ 78.100 mm (3.0736 to 3.0748 in)
Installation interference	0.034 ÷ 0.100 mm (0.0013 to 0.0039 in)
Inner diameter of bush	63.195 ÷ 63.265 mm (2.4880 to 2.4907 in)
Outer diameter of pin	62.954 ÷ 63.000 mm (2.4785 to 2.4803 in)
Clearance	0.195 ÷ 0.311 mm (0.0077 to 0.0122 in)
G. Diameter of bush seat in frame	78.000 ÷ 78.046 mm (3.0709 to 3.0727 in)
Outer diameter of bush	78.070 ÷ 78.100 mm (3.0736 to 3.0748 in)
Installation interference	0.034 ÷ 0.100 mm (0.0013 to 0.0039 in)
Inner diameter of bush	63.195 ÷ 63.265 mm (2.4880 to 2.4907 in)
Outer diameter of pin	62.954 ÷ 63.000 mm (2.4785 to 2.4803 in)
Clearance	0.195 ÷ 0.311 mm (0.0077 to 0.0122 in)
H. Diameter of bush seat in link	95.000 ÷ 95.054 mm (3.7401 to 3.7423 in)
Outer diameter of bush	95.090 ÷ 95.125 mm (3.7437 to 3.7451 in)
Installation interference	0.036 ÷ 0.125 mm (0.0014 to 0.0049 in)
Inner diameter of bush	80.210 ÷ 80.280 mm (3.1579 to 3.1606 in)
Outer diameter of pin	79.954 ÷ 80.000 mm (3.1478 to 3.1496 in)
Clearance	0.210 ÷ 0.326 mm (0.0083 to 0.0128 in)
I. Diameter of bush seat in frame	95.000 ÷ 95.054 mm (3.7401 to 3.7423 in)
Outer diameter of bush	95.090 ÷ 95.125 mm (3.7437 to 3.7451 in)
Installation interference	0.036 ÷ 0.125 mm (0.0014 to 0.0049 in)
Inner diameter of bush	80.210 ÷ 80.280 mm (3.1579 to 3.1606 in)
Outer diameter of pin	79.954 ÷ 80.000 mm (3.1478 to 3.1496 in)
Clearance	0.210 ÷ 0.326 mm (0.0083 to 0.0128 in)
J. Tightening torque of support securing screws	96 ÷ 106 Nm (708.06 to 781.81 lbf.ft)
K. Tightening torque of pin locking plate securing screws	7.1 daNm (52.37 lbf.ft)

7.1.1 FUSES

The fuses are located inside the respective boxes **A** and **B** in the cab.

Depending on the type of machine set-up, the position of the fuse boxes may change. In particular, in the case of the CAB version, the boxes are installed vertically on the left side of the instrument panel, whereas the two boxes are inside the glove compartment, in a horizontal position, for the ROPS version. Remove the snap-on lids on boxes **A** and **B** to get to the fuses.

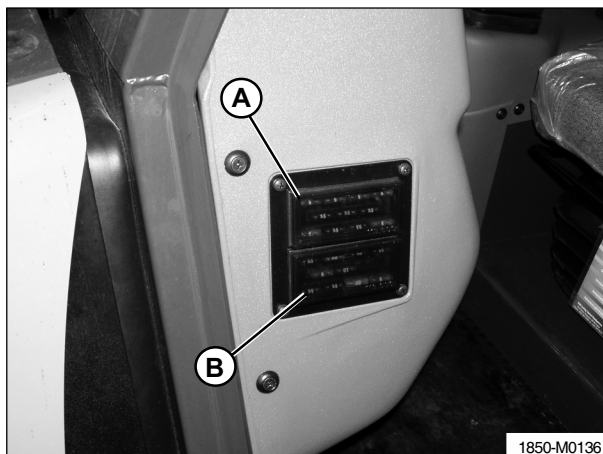

WARNING

Always disconnect the battery grounding cable prior to cleaning, repairing, connecting or disconnecting any wire of the electrical system, to prevent personal injuries.

Always keep all lights mounted on the machine in working conditions. Replace all burnt-out bulbs as soon as possible.

Note – *In case a fuse blows-up, replace it at once. Search for the cause of the trouble. If the trouble reoccurs, have the system checked by specialised personnel.*



Rear wiper motor

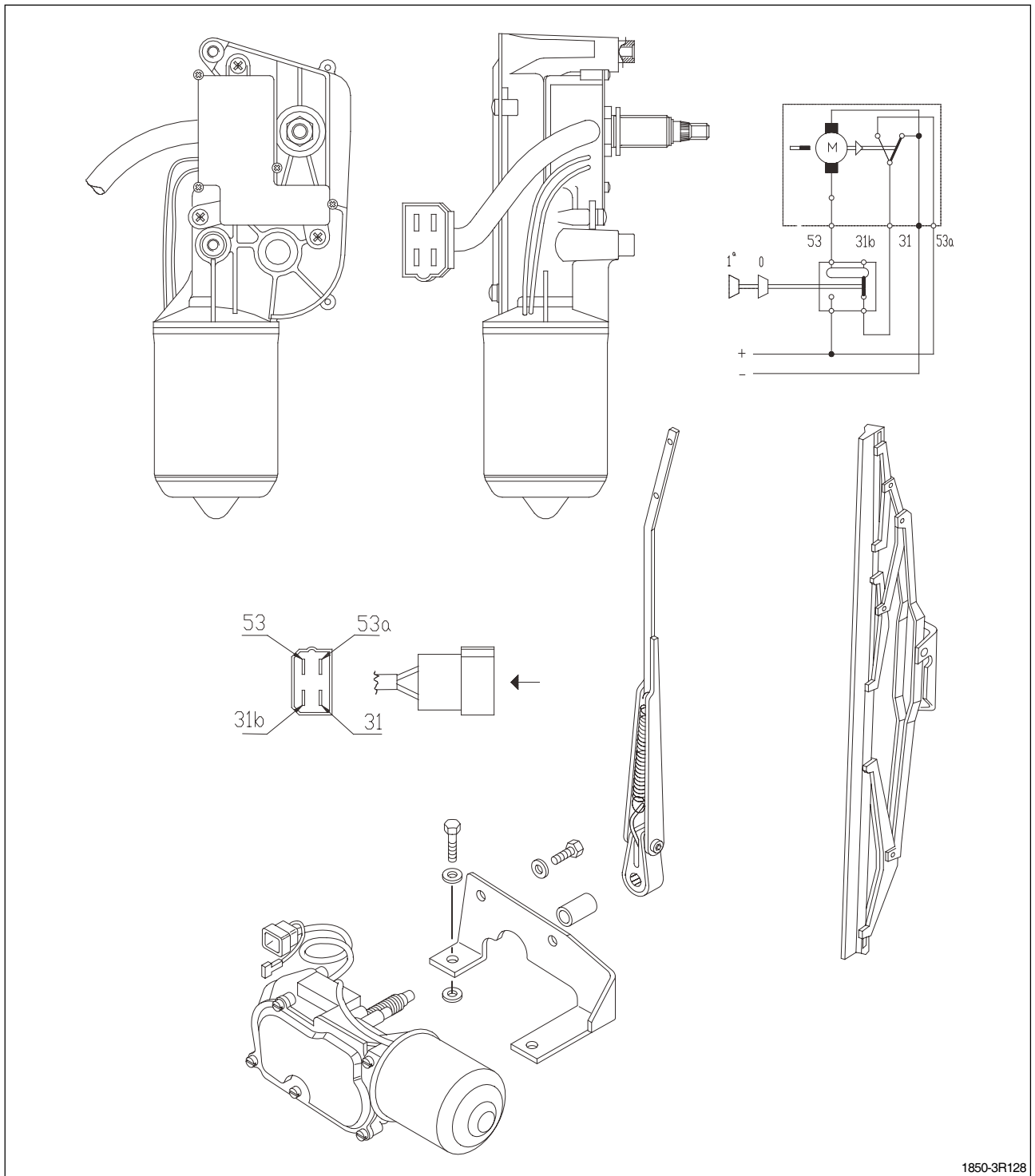

1850-3R128

Rear wiper motor:

- 53: GREEN - BLACK (V-N)
- 53a: LIGHT BLUE - RED (A-R)
- 31: BLACK (N)
- 31b: LIGHT BLUE - WHITE (A-B)

7. HYDRAULIC OIL FILTER CLOGGING SENSOR

WIRES

580 To monitor

000 To ground

Thread: M18 x 1,5
 Setting: 2 ÷ 2.2 bar (29 ÷ 31.91 psi)
 Wrench: 22 mm (0.866 in)

LOCATION - On hydraulic oil reservoir.

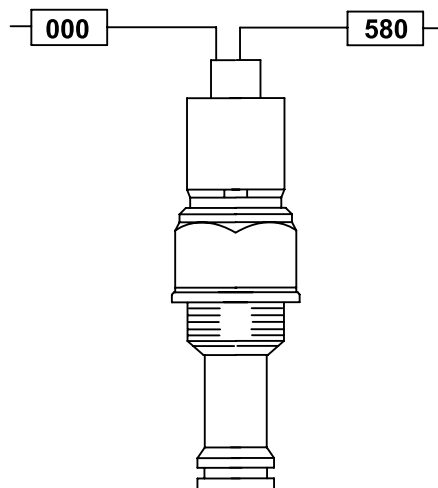

SM9523

8. BRAKES AND STEERING CLUTCHES OIL LOW PRESSURE SENSOR

WIRES

611 To monitor

000 To ground

Thread: M10 x 1 taper
 Setting: 12.5 ÷ 11 bar
 (181.30 ÷ 159.54 psi)
 Wrench: 27 mm (1.063 in)
 Torque wrench: 3.5 daNm (25.84 lbf.ft)

The sensor is normally closed, it opens when the pressure drops or reaches the setting value.

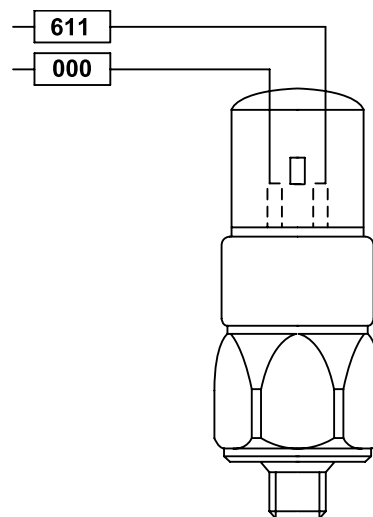

SM9524

9. TRANSMISSION OIL LOW PRESSURE SENSOR

WIRES

581 To monitor

000 To ground

Thread: M10 x 1 taper
 Setting: 12.5 ÷ 11 bar
 Wrench: 27 mm (1.063 in)
 Torque wrench: 3.5 daNm (3.5 lbf.ft)

The sensor is normally closed, it opens when the pressure drops or reaches the setting value.

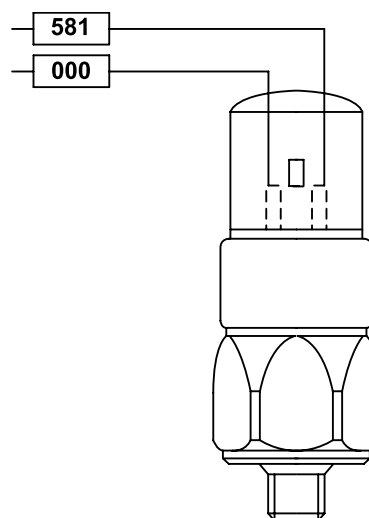

SM9525

BLADE CONTROL PILOT VALVE

(Ref. Ma, hydraulic diagram)

Pin (X2)		
	LIFT	
1	S1	white
2	S2	grey
3	S1 + S2 to ground	green
	TILT	
4	S3	yellow
5	S4	brown
6	S3 + S4 to ground	red
	ANGLE	
7	S5	blue
8	S6	black
9	S5 + S6 to ground	violet
10		
11		
12		

forward/reverse

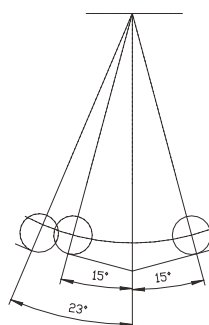

left/right

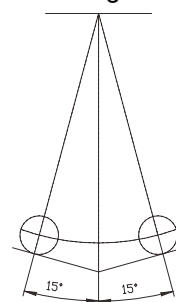

angle function

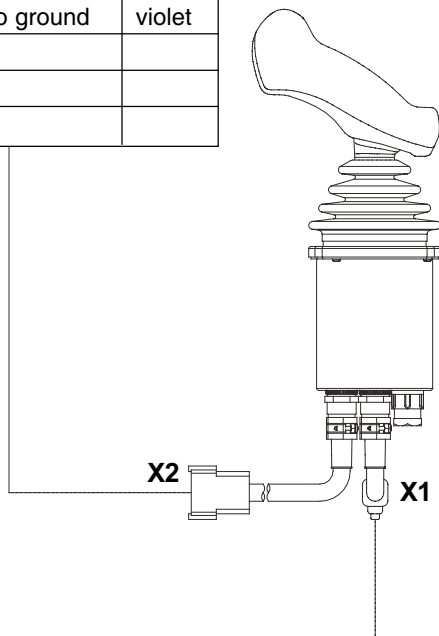
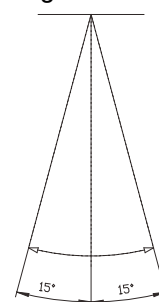

supply voltage: +8V ... +32V
 PWM - output: max. 1A
 frequency: 150/200 Hz ±10 Hz

X1: 8 pole DEUTSCH connector type: DT04-8P

X2: 12 pole DEUTSCH connector type: DT06-12S

Pin (X1)		
1	8V ... +32V	white
2	0V	grey
3	output I (max)=2A	green
4	current input 4-20mA	yellow
5	Rxd	brown
6	Txd	red
7	0V	
8		

Compressor oil

Use compressor oil made specifically for use with R134a.

R134a system compressor oil has an extremely high moisture absorption capacity.



WARNING

Cap the oil container after use and the air conditioner system parts, when servicing.

Never mix compressor oil with other types of oil.

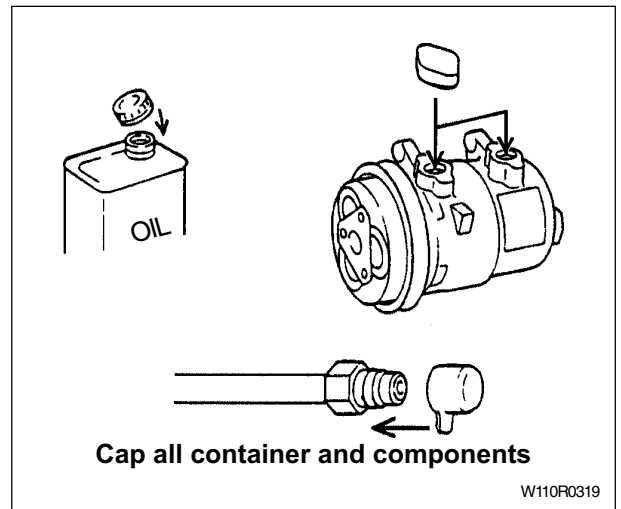

Fig. 8-5

The oil must be replaced or replenished in the following cases:

- when refrigerant or oil leaks from the system;
- when refrigerant is suddenly discharged from the system;
- when system components are replaced.

Note ñ The oil plug O-Ring must be replaced with a new one.

Refrigerant charge inspection

As shown in the left hand figure, R134a compressor oil will not blend with refrigerant (R134a) at certain temperatures. At these temperatures, the refrigerant may appear 'cloudy' when checked using the sightglass, and the charge may be mistakenly judged as insufficient.

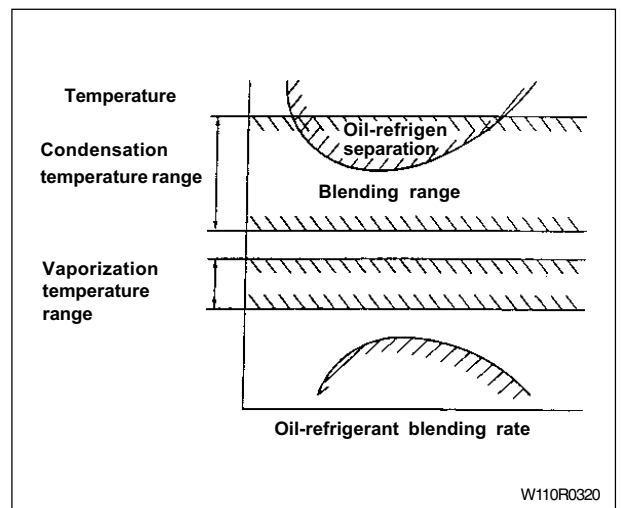

Fig. 8-6

CLICK HERE TO **DOWNLOAD** THE COMPLETE MANUAL

- Thank you very much for reading the preview of the manual.
- You can download the complete manual from: www.heydownloads.com by clicking the link below



- Please note: If there is no response to CLICKING the link, please download this PDF first and then click on it.

CLICK HERE TO **DOWNLOAD** THE COMPLETE MANUAL