



SERVICE MANUAL  
**WHEEL LOADER**  
**521E**  
**TIER 3**

84243970  
(Replaces 87728450)

Revised June 2009  
Issued February 2008

CLICK HERE TO **DOWNLOAD** THE COMPLETE MANUAL

- Thank you very much for reading the preview of the manual.
- You can download the complete manual from: [www.heydownloads.com](http://www.heydownloads.com) by clicking the link below



- Please note: If there is no response to CLICKING the link, please download this PDF first and then click on it.

CLICK HERE TO **DOWNLOAD** THE COMPLETE MANUAL

## TORQUE SPECIFICATIONS - METRIC HARDWARE

Use the following torques when specifications are not given.

These values apply to fasteners with coarse threads as received from supplier, plated or unplated, or when lubricated with engine oil. These values do not apply if graphite or Molydisulfide grease or oil is used.

<b>Grade 8.8 Bolts, Nuts, and Studs</b>		
		
Size	Pound-Inches	Newton metres
M4	24 to 36	3 to 4
M5	60 to 72	7 to 8
M6	96 to 108	11 to 12
M8	228 to 276	26 to 31
M10	456 to 540	52 to 61
Size	Pound-Feet	Newton metres
M12	66 to 79	90 to 107
M14	106 to 127	144 to 172
M16	160 to 200	217 to 271
M20	320 to 380	434 to 515
M24	500 to 600	675 to 815
M30	920 to 1100	1250 to 1500
M36	1600 to 1950	2175 to 2600

<b>Grade 10.9 Bolts, Nuts, and Studs</b>		
		
Size	Pound-Inches	Newton metres
M4	36 to 48	4 to 5
M5	84 to 96	9 to 11
M6	132 to 156	15 to 18
M8	324 to 384	37 to 43
Size	Pound-Feet	Newton metres
M10	54 to 64	73 to 87
M12	93 to 112	125 to 150
M14	149 to 179	200 to 245
M16	230 to 280	310 to 380
M20	450 to 540	610 to 730
M24	780 to 940	1050 to 1275
M30	1470 to 1770	2000 to 2400
M36	2580 to 3090	3500 to 4200

### Grade 12.9 Bolts, Nuts, and Studs

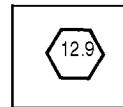

Usually the torque values specified for grade 10.9 fasteners can be used satisfactorily on grade 12.9 fasteners.

# MAINTENANCE POINTS

## Model 521E

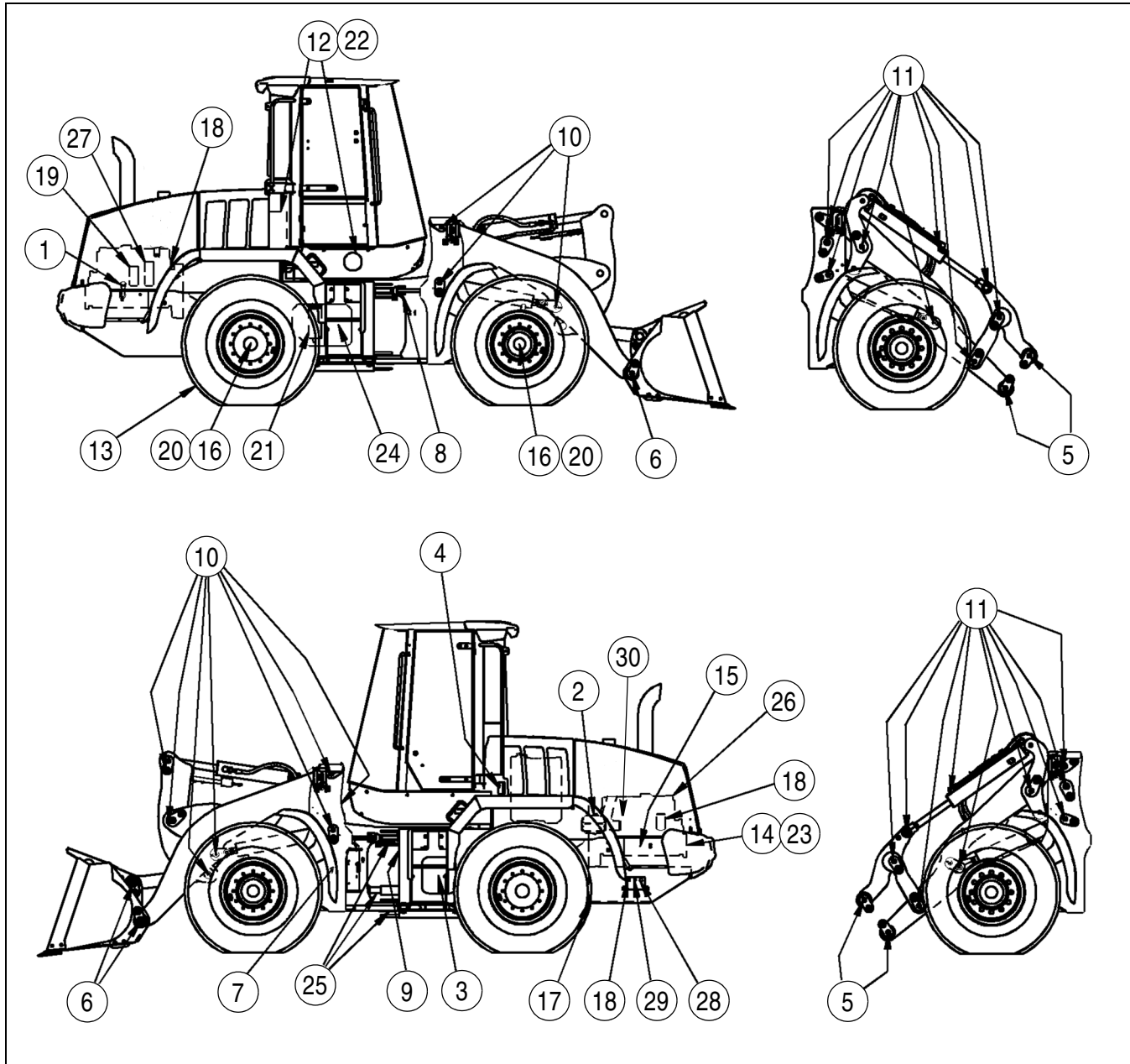

BS08B289

See your Operators manual for maintenance of safety related items and for detailed information of the service items on this chart. Operators and service manuals are available for this machine from your dealer.

If you operate the machine in severe conditions, lubricate and service the machine more frequently.

### STEP 7

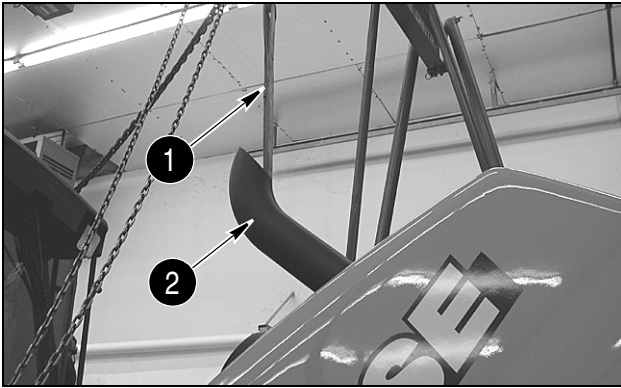

BD03A231

Double up a nylon lifting strap (1) and slide through the exhaust stack (2) on the hood.

### STEP 8

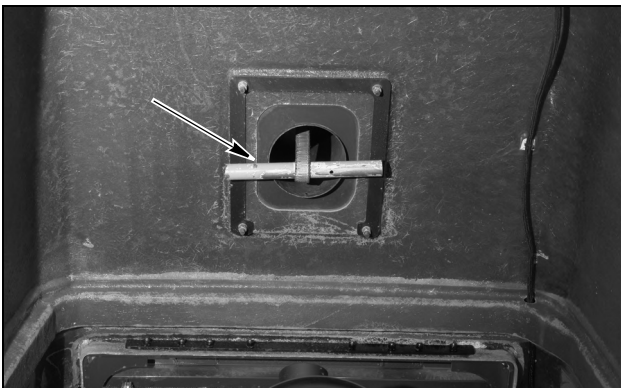

BD07N564-01

Place a solid steel bar through the strap, raise the hood and release tension on the lifting motor.

### STEP 9

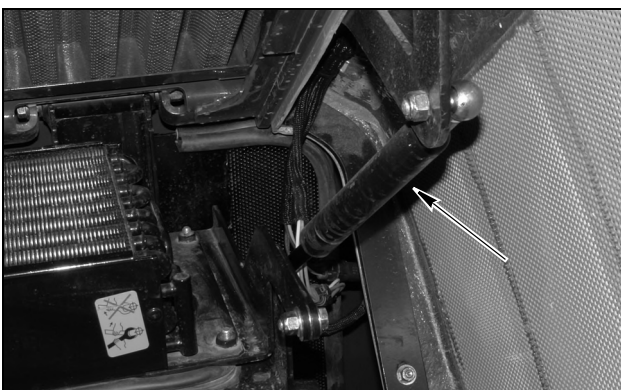

BD07N597-01

Remove the right front lift cylinder from the hood. Repeat the procedure for the left hand side.

### STEP 10



BD07N565-01

Remove the rear lift cylinder from the machine.

### STEP 11



BD07N566-01

Tag and disconnect hood wiring harness connector and backup alarm connector from rear chassis wiring harness connector.

### STEP 12

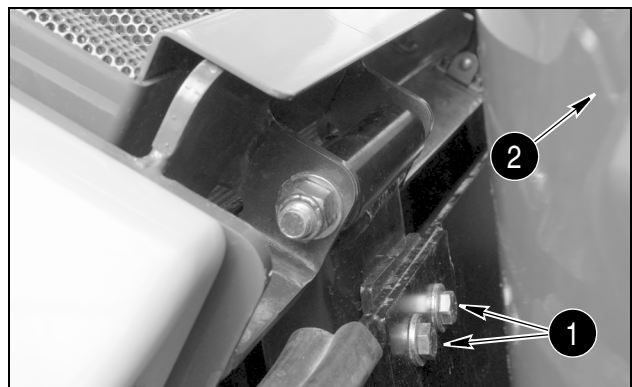

BD07N567-01

Have another person balance the hood, and remove the hood hinge mounting bolts (1) located outside the hood by the cab (2) from the cooler frame. Repeat procedure for the other side.

**STEP 56**

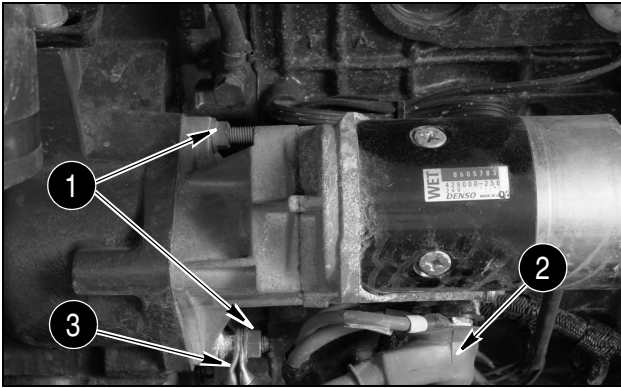

BD07N581-01

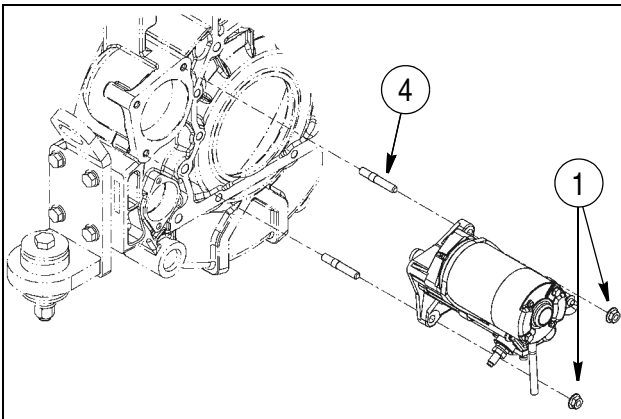

BS08A030

Install the wires (2) to the starter solenoid, install the ground cable and ground strap (3), to the starter. Torque starter mounting nuts (1) to 40 to 50 Nm (29 to 37 pound-feet). Remove and discard tags.

**NOTE:** If the starter mounting studs (4) have to be replaced apply Loctite 747 primer to studs and holes and apply Loctite 271 to each stud and hole and torque to 19 to 29 Nm (14 to 21 pound-feet).

**STEP 57**

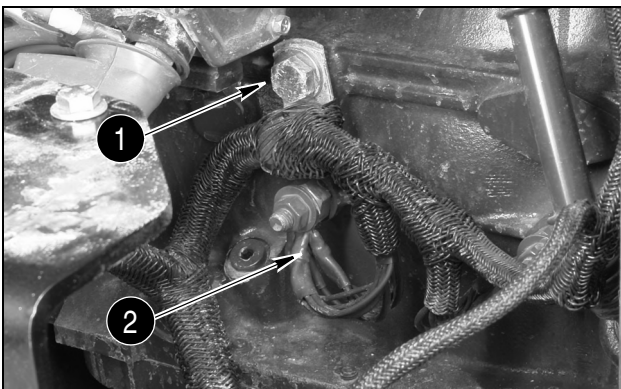

BD07N582-01

Install bolt securing wiring harness (1) clamp to the engine. Install ground wires (2) to the engine.

**STEP 58**

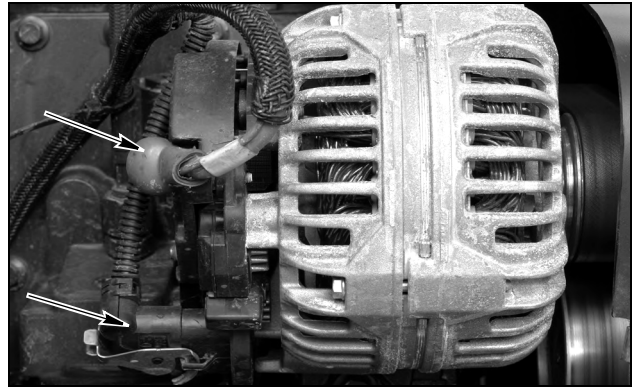

BD07N575-01

Connect the wiring to the alternator. Remove and discard tags.

**STEP 59**

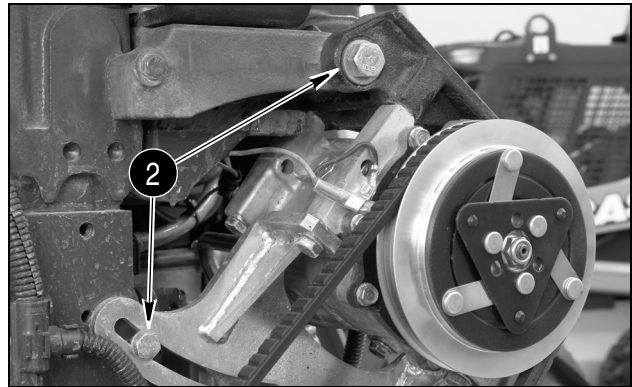

BD07N579-01

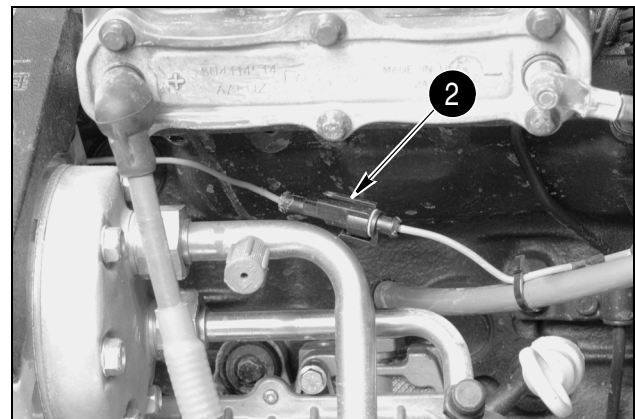

BD07N578-01

If loader is equipped with air conditioning, mount the compressor using the two mounting bolts (2), connect the engine wiring harness connectors to air compressor clutch connector (1). Remove and discard tags.

### STEP 23

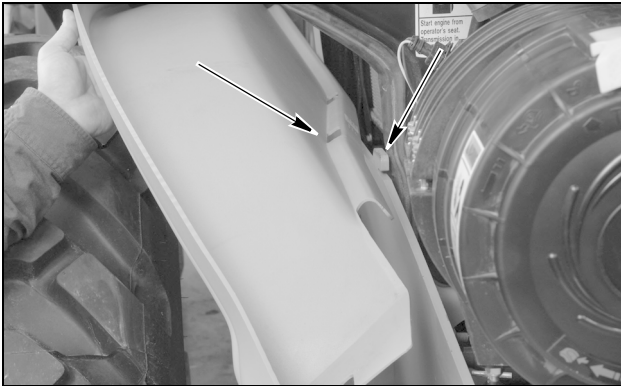

BD07N595-01

Align the slots in the fender with the tabs on the body of the machine.

### STEP 24



BD07N593-01

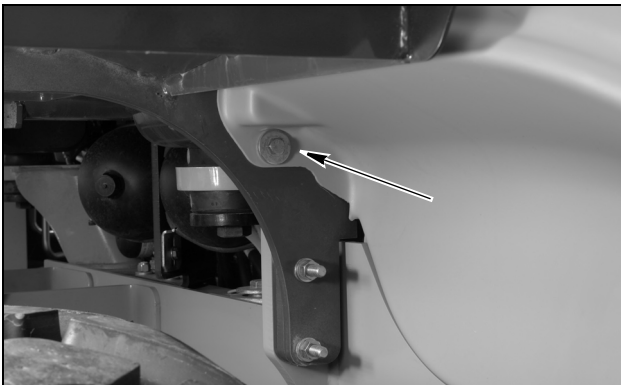

BD07N594-01

Align the whole in the fender and install the bolt and washer.

### STEP 25

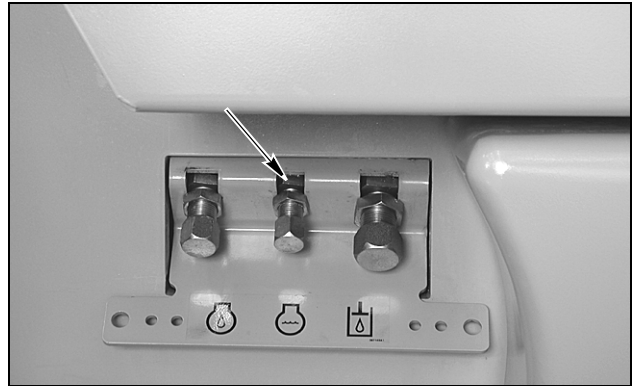

BD02N160

Check that coolant drain cap is tight.

### STEP 26

Fill engine coolant system with a solution of 50% Ethylene Glycol and 50% water. Cooling system capacity is 22 liter (5.8 gallon). Install the radiator cap. Fill the coolant reservoir up to the FULL mark on the reservoir.

### STEP 27

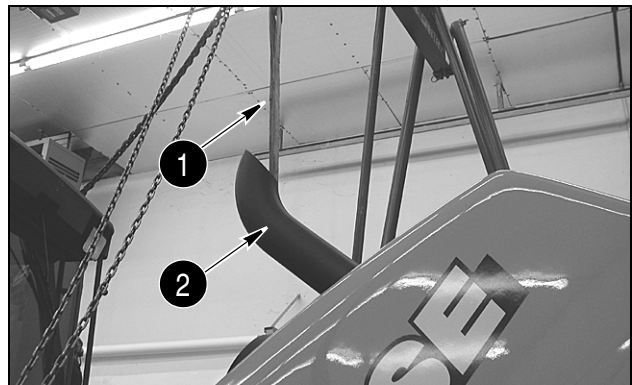

BD03A231

Double up a nylon lifting strap (1) and slide through the exhaust stack (2) on the hood.

### STEP 28

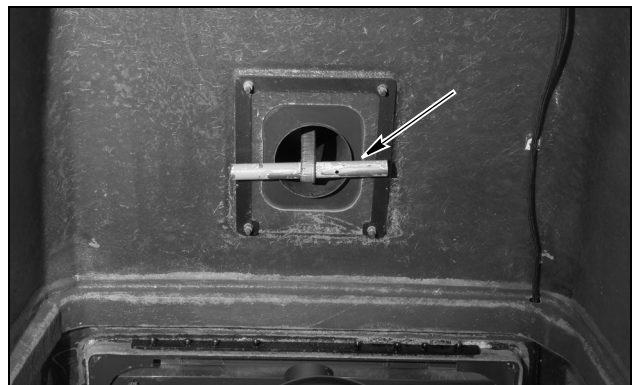

BD07N564-01

Place a solid steel bar through the strap, raise the hood and release tension on the lifting motor.

### Test No. 3 - Hydraulic Stall

1. Sit in the seat.
2. Start the engine and run the engine at low idle.
3. Increase the engine speed to full throttle.
4. Hold the bucket control lever in the ROLLBACK position and raise the lift arms.

**NOTE:** *The stall speed must be read while the lift arms are in motion.*

5. Check the engine speed.
6. Release the bucket control lever.
7. Decrease the engine speed to low idle.
8. Lower the bucket to the ground.
9. Stop the engine.

### Understanding the Results of Test No. 3

1. If the engine speed was as specified, the engine and hydraulic system are good.
2. If the engine speed was more or less than specified the main relief setting may be too low or too high. See Section 8002 for troubleshooting information.
3. If the engine speed was less than specified in all tests, the engine is probably the cause.



## BELT INSTALLATION

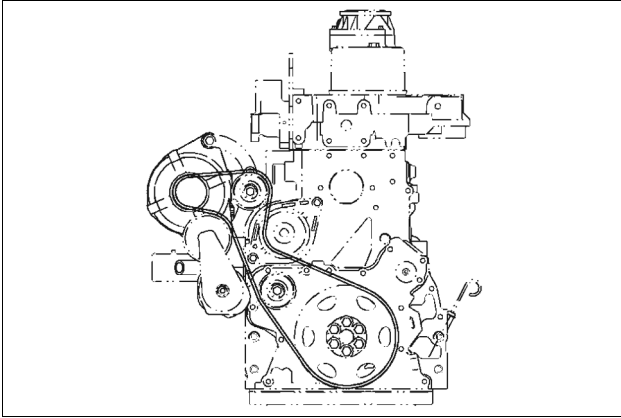

BS08A051

**WITH OUT AIR CONDITIONING**

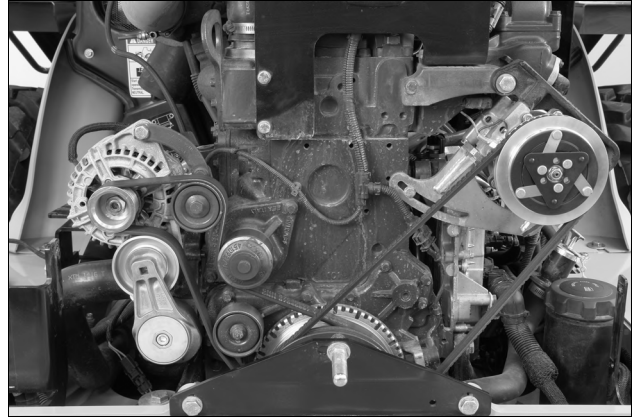

BD07N606-01

**WITH AIR CONDITIONING**

### Wire Identification Codes

**21C Bk - 1.0**

Wire Size (mm<sup>2</sup>)    0.8 mm    1.0 mm    2.0 mm    5.0 mm

Wire Color	Bk = Black	DU = Dark Blue	S = Gray	LG = Light Green	K = Pink
	T = Tan	W = White	N = Brown	G = Green	U = Blue
	LU = Light Blue	Or = Orange	R = Red	P = Purple	Y = Yellow

Wire Identification			From Connector		To Connector	
Wire	Circuit	Color, Size, and Material	Connector	Cavity	Connector	Cavity
0 B23	Back Light Ground	Bk 0.8 GXL	SRWP, Rear Wiper Switch	7	SPL-BCK-LT-GD, Spl Bk Lt Grnd	L
0 B24	Back Light Ground	Bk 0.8 GXL	SHZ, Hazard Switch	7	SPL-PED-BL-GD, Spl Bk Lt Grnd 6 Pck	C
0 B25	Hood Up Control Ground	Bk 1.0 GXL	SPL-HOOD-GRND, Hood Gnd 6 Pck	D	ECC, Work Lights	B2
0 B26	Buzzer/Switch Pad Ground	Bk 0.8 GXL	SPL-BUZ, Ultrasonic	A	SPL-BCK-LT-GD2, Spl Bk Lt Grnd	6
0 B27	Buzzer Ground	Bk 0.8 GXL	SPL-BUZ, Ultrasonic	A	BUZ, AIC Buzzer	2
0 B28	Switch Pad Ground	Bk 0.8 TXL	SW-PD, Switch Pad	10	SPL-BUZ, Ultrasonic	A
0 B29	RTT/Float Ground	Bk 0.8 GXL	SPB, Parking Brake Switch	7	SPL-PED-BL-GD, Spl Bk Lt Grnd 6 Pck	E
0 B30	Back Light Ground	Bk 0.8 GXL	SETHR, Ether Switch	7	SPL-PED-BL-GD, Spl Bk Lt Grnd 6 Pck	D
0 BA	Pedestal Gnd Strap	Bk 5.0 SXL	GND-PDST, Ground A	1	GND-PDST2, Ground A	1
0 BAC	EDC7 Ground	Bk 2.0 SXL	SPL-EDC1, Ultrasonic	A	GND-ENG2, WIF, EDC	1
0 BAE	EDC7 Sender Ground	Bk 1.0 SXL	RECT, Engine Coolant Temp	B	GND-ENG7, Tranny, Cool Temp	1
0 BAF	Coolant Lever Sender Ground	Bk 1.0 SXL	CLS, Cool Jump-Cool Sender	B	GND-ENG7, Tranny, Cool Temp	1
0 BAG	Hood Grounds (EURO)	Bk 1.0 SXL	GND-ENG4, Rear Lighting	1	E-HD, Trans Hood	c
0 BAG N	Hood Grounds (NA)	Bk 1.0 SXL	ENG-H, Engine to Hood	1	GND-ENG4, Rear Lighting	1
0 BAH	QSM11 Ground	Bk 0.8 GXL	SPL-EDC1, Ultrasonic	A	QSM11, Engine Controller	29
0 BAI	QSM11 Ground	Bk 0.8 GXL	SPL-EDC1, Ultrasonic	A	QSM11, Engine Controller	30
0 BAJ	QSM11 Ground	Bk 0.8 GXL	SPL-EDC1, Ultrasonic	A	QSM11, Engine Controller	39
0 BAK	QSM11 Ground	Bk 0.8 GXL	SPL-EDC1, Ultrasonic	A	QSM11, Engine Controller	40
0 BAL	QSM11 Ground	Bk 0.8 GXL	SPL-EDC1, Ultrasonic	A	QSM11, Engine Controller	41
0 BAM	Ether Relay Signal Ground	Bk 1.0 SXL	PRM-C2, PRM signal	B	GND-ENG2, WIF, EDC	1
0 BAN	Ether Start Ground	Bk 1.0 SXL	ETHR, Ether Solenoid	B	GND-ENG3, Spl Pck Washer Motor	1
0 BAP	QSM11 Ground	Bk 0.8 GXL	SPL-EDC1, Ultrasonic	A	QSM11, Engine Controller	50
0 BAR	WIF Body Ground	Bk 1.0 SXL	GND-WIF, Gnd WIF Ring Term	1	GND-ENG6, Dedicated	1
0 BAS	Rear Axle Temp Sensor Ground	Bk 1.0 SXL	HOT-RA, Rear Axle Oil Temp	2	GND-ENG7, Tranny, Cool Temp	1
0 BB	Fan Reverse Solenoid Ground	Bk 1.0 SXL	YFR, Fan Reverse Sol Opt	2	SPL-FAN, Ultrasonic	A
0 BC	EDC7 Grnd	Bk 1.0 GXL	SPL-EDC1, Ultrasonic	A	EDC7, Engine Controller	11

## Wire Identification Codes

21C Bk - 1.0

Wire Size (mm<sup>2</sup>) 0.8 mm 1.0 mm 2.0 mm 5.0 mm

Wire Color

Bk = Black	DU = Dark Blue	S = Gray	LG = Light Green	K = Pink
T = Tan	W = White	N = Brown	G = Green	U = Blue
LU = Light Blue	Or = Orange	R = Red	P = Purple	Y = Yellow

Wire Name

Wire Identification			From Connector		To Connector	
Wire	Circuit	Color, Size, and Material	Connector	Cavity	Connector	Cavity
19L B	Pwr Converter Fused Power	Or 2.0 GXL	CNV, 24V to 12V Pwr Conver	2	SPL-CNV, Ultrasonic	A
19M	Sec. Steering Accessory Fused Pwr	Or 0.8 GXL	CAB-T, Cab Transmission	3	ECA, Elect Center A	C7
19M A	Sec. Steering Accessory Fused Pwr	Or 1.0 SXL	TRANS, Cab Transmission	3	TR-SS, Sec. Steering Module Opt	A
19M C	Sec. Steering Accessory Fused Pwr	Or 1.0 SXL	SSM, Sec. Steering Module	7	SS-TR, Sec. Steering Mod Trans	A
19N	Seat Compressor Fused Pwr	Or 1.0 GXL	SC, Seat Compressor Motor	A	ECA, Elect Center A	C6
19P	Pin Engage/Fan Fused Pwr	Or 0.8 GXL	SPL-PIN, Spl Back Lgt Pwr	B	ECA, Elect Center A	A7
19P A	Pin Engage Sw Fused Pwr	Or 0.8 GXL	SPE, Pin Engage Sw	2	SPL-PIN, Spl Back Lgt Pwr	A
19P C	Fan Rev Sw Fused Pwr	Or 0.8 GXL	SFC, Fan Control Switch	5	SPL-PIN, Spl Back Lgt Pwr	C
19P D	Fan Rev Relay Fused Pwr	Or 0.8 GXL	SPL-PIN, Spl Back Lgt Pwr	E	ECB, Elect Center B	D7
19P E	Fan Rev Relay Fused Pwr	Or 0.8 GXL	SPL-PIN, Spl Back Lgt Pwr	F	ECB, Elect Center B	B7
19R	Sec. Steering Ign Fused Pwr	Or 0.8 GXL	DM, Diode OR	C	SPL-2 Ultrasonic	A
19RR	Sec. Steering Ign Fused Pwr	Or 0.8 GXL	DM, Diode OR	A	ECA, Elect Center A	A4
19R A	Sec. Steering Ign Fused Pwr	Or 1.0 SXL	TRANS, Cab Transmission	4	TR-SS, Sec. Steering Module Opt	B
19R C	Sec. Steering Ign Fused Pwr	Or 1.0 SXL	SSM, Sec. Steering Module	1	SS-TR, Sec. Steering Mod Trans	B
19R D	Alternator Resistor Fused Pwr	Or 0.8 GXL	SPL-2, Ultrasonic	A	216F, Alternator Resistor	1
19R E	Sec. Steering Ign Fused Pwr	Or 0.8 GXL	SPL-2, Ultrasonic	A	CAB-T, Cab Transmission	4
19S1	Sec. Steering Fused Pwr	Or 1.0 GXL	SS, Sec. Steering Fused Pwr	1	CAB-T, Cab Transmission	26
19S1 E	Sec. Steering Fused Pwr	Or 1.0 SXL	TRANS, Cab Transmission	26	TR-SS, Sec. Steering Module Opt	E
19S1 X	Sec. Steering Fused Pwr	R 1.0 SXL	SSM, Sec. Steering Module	3	SS-TR, Sec. Steering Module Trans	E
19S B	AIC Delay Fused Power	Or 0.8 GXL	SPL-DKY3, Ultrasonic	A	ECD, Elect Center D	AA3
19S C	AIC Delay Fused Power	Or 0.8 TXL	SPL-DKY3, Ultrasonic	A	AIC-2, Advanced Instr Cluster 2	20
19S D	AIC Delay Fused Power	Or 0.8 TXL	SPL-DKY3, Ultrasonic	A	AIC-2, Advanced Instr Cluster 2	14
19T A	TECM Delay Fused Power	Or 0.8 TXL	TECM, Trans	23	ECD, Elect Center D	AA1
19U	Horn Relay Fused Power	Or 0.8 GXL	SPL-HRN, Ultrasonic	A	ECC, Work Lights	A6
19U A	Horn Relay Fused Power	Or 0.8 GXL	SPL-HRN, Ultrasonic	A	ECC, Work Lights	B7
19U B	Beacon Dome Lt Fused Pwr	Or 1.0 GXL	SPL-LT, Ultrasonic	A	ECC, Work Lights	A1
19U C	Dome Lt Fused Pwr	Or 0.8 GXL	ROOF, Roof to Cab Connection	D	LDM1, Dome Light B+	1

## Wire Identification Codes

21C Bk - 1.0

Wire Size (mm<sup>2</sup>) 0.8 mm 1.0 mm 2.0 mm 5.0 mm

Wire Color	Bk = Black	DU = Dark Blue	S = Gray	LG = Light Green	K = Pink
Wire Name	T = Tan	W = White	N = Brown	G = Green	U = Blue
	LU = Light Blue	Or = Orange	R = Red	P = Purple	Y = Yellow

Wire Identification			From Connector		To Connector	
Wire	Circuit	Color, Size, and Material	Connector	Cavity	Connector	Cavity
45N B	Flasher OPP Side Control	N 0.8 GXL	FLSHR, Flasher Module	12	64M, Flasher Connector	1
45R	Right Turn Signal	N 1.0 SXL	FRONT, Cab Front Chassis	3	LRF, Lights RH	5
45R 9	Right Turn Signal	N 1.0 SXL	HD-9, Hood to Engine	4	LRR-9, RH Rear Comb Light	2
45R A	Right Turn Signal	N 1.0 SXL	ENG, Engine Cab	12	LRR-E, RH Rear Comb Light	2
45R AN	Right Turn Signal	N 1.0 SXL	ENG, Engine Cab	12	ENG-H, Engine to Hood	4
45R B	Right Turn Signal	N 0.8 GXL	CAB-E, Cab Engine	12	SPL-PK3, Splice 3-4 Way	H
45R BN	Right Turn Signal	N 1.0 SXL	HD-N, Hood to Engine	4	LRR-N, RH Rear Comb Light	C
45R C	Right Turn Signal	N 0.8 TXL	SPL-PK3, Splice 3-4 Way	E	AIC-2, Adv Instrument Cluster 2	10
45R D	Right Turn Signal	N 0.8 GXL	CAB-F, Cab Front Chassis	3	SPL-PK3, Splice 3-4 Way	G
45R E	Right Turn Signal	N 0.8 GXL	FLSHR, Flasher Module	7	SPL-PK3, Splice 3-4 Way	F
46 C	Beacon Switched Power	K 1.0 GXL	CAB-RF, Cab to Roof Conn.	E	SBE, Beacon Switch	3
46 D	Beacon Switched Power	K 1.0 GXL	ROOF, Roof to Cab Conn.	E	LBEPWR, Light Beacon power	1
46 E	Beacon Switched Power	K 1.0 GXL	LBEE, Light Beacon Exten	A	LBEP, Light Beacon power	1
49A	Back Light Power	S 0.8 GXL	HVAC1, HVAC1	3	SPL-BCK-LGT, Spl Back Lgt Pwr	F
49S	Back Light Power	S 0.8 GXL	STA, Trans Auto Switch	8	SPL-BCK-LGT, Spl Back Lgt Pwr	J
49U	Back Light Power	S 0.8 GXL	SETHR, Ether Switch	8	SPL-PED-BL, Spl Back Lgt Pwr 6 Pck	D
49 A	Back Light Power	S 0.8 GXL	SWL, Work Lights Switch	8	SPL-BCK-LGT, Spl Back Lgt Pwr	M
49 B	Back Light Power	S 0.8 GXL	SBE, Beacon Switch	8	SPL-BCK-LGT, Spl Back Lgt Pwr	L
49 C	Back Light Power	S 0.8 GXL	SRWP, Rear Wiper Switch	8	SPL-BCK-LGT, Spl Back Lgt Pwr	C
49 D	Back Light Power	S 0.8 GXL	SHZ, Hazard SWitch	8	SPL-PED-BL, Spl Back Lgt Pwr 6 Pck	C
49 E	Back Light Power	S 0.8 GXL	SPL-BCK-LGT2, Spl Back Lgt Pwr	A	SPL-BCK-LGT, Spl Back Lgt Pwr	K
49 F	Back Light Power	S 0.8 GXL	SPE, Pin Engage Switch	10	SPL-BCK-LGT2, Spl Back Lgt Pwr	F
49 G	Back Light Power	S 0.8 GXL	SRC, Ride control Switch	8	SPL-BCK-LGT2, Spl Back Lgt Pwr	K
49 H	Back Light Power	S 0.8 GXL	STE, Trans Enable Switch	8	SPL-BCK-LGT, Spl Back Lgt Pwr	D
49 J	Back Light Power	S 0.8 GXL	SRTD, Detent Switch	8	SPL-BCK-LGT2, Spl Back Lgt Pwr	C

**1 – Starting Relay**

Located in the right side of the engine compartment on cooling fan housing, open engine compartment to gain access.

Check Points	Correct Reading	Possible Cause of Bad Reading
Terminal for wire 0-GB to ground	Continuity	Bad ground circuit.
<b>NOTE:</b> Put the master disconnect switch in the ON position.		
Terminal for wire 1-Z to ground	24 volts	Check circuit to batteries.
<b>NOTE:</b> Put the transmission in NEUTRAL. Have another person hold the ignition switch in the START position.		
Terminal for wire 21D to ground	24 volts	Check crank control relay (4), also check circuit 21D.
Terminal for wire 1-BB to ground	24 volts	Bad starting relay.

**2 – Resistor**

Located in the cab access panel for fuses and relays.

**NOTE:** Turn master disconnect switch off, disconnect terminals from resistor.

Check Points	Correct Reading	Possible Cause of Bad Reading
Between terminals of resistor	75 ohms	Bad resistor.

**3 – Alternator**

Located on left side of engine, open engine compartment to gain access.

Check Points	Correct Reading	Possible Cause of Bad Reading
Between housing of alternator and ground	Continuity	Bad ground connection.
<b>NOTE:</b> Put the master disconnect switch in the ON position.		
Between the B+ terminal of alternator and ground	24 volts	Check circuit to positive post of left battery. Bad master disconnect switch.
Between terminal for wire 1-BA and ground	24 volts	Bad wire 1-BA.
<b>NOTE:</b> Put the ignition switch in the ON position.		
Between the B+ terminal of alternator and ground	24 volts	Check circuit to positive post of left battery.
Terminal for wire 14 to ground	20 volts	Check circuit 14, 75 ohm resistor, and diode module. Bad fuse ECA-F4. Check power relay module A, and 105 ampere circuit breaker in engine compartment of machine.
<b>NOTE:</b> If the readings are good, repair or replace the alternator.		

**22 – Water In Fuel Sensor**

Located in the right side of the engine compartment on water separator housing, open engine compartment to gain access.

Check Points	Correct Reading	Possible Cause of Bad Reading
Terminal for wire 0-BP to ground	Continuity	Bad ground circuit.
<b>NOTE:</b> Put the master disconnect switch and the ignition switch in the ON position.		
Terminal for wire 18J-H to ground	24 volts	Check fuse ECD-F2, power relay module B (14), also check circuit 18J.
<b>NOTE:</b> Remove sensor from filter and place probes in water.		
Terminal for wire 35W to ground	24 volts	Bad water separator sensor.

**23 – Throttle Potentiometer**

Located below cab under throttle pedal.

Check Points	Correct Reading	Possible Cause of Bad Reading
<b>NOTE:</b> Put the master disconnect switch in the ON position and the ignition switch in ON position.		
Terminal for wire 24S to 24R	5 volts	Bad EDC7 (24). Also check wire 24S.
Terminal for wire 24R to ground	Continuity	Bad EDC7 (24). Also check wire 24R.
<b>NOTE:</b> Throttle pedal in low idle position.		
Terminal for wire 24B to 24R	$0.4 \pm 0.025$ volts	Bad potentiometer.
<b>NOTE:</b> Throttle pedal in high idle position.		
Terminal for wire 24B to 24R	$4.0 \pm 0.1$ volts	Bad potentiometer.
<b>NOTE:</b> Put the ignition switch in OFF position and the master disconnect switch in the OFF position. Disconnect connector RTHP. Throttle pedal in low idle position.		
Between pin 1 and 6 at pedal	Open	Bad potentiometer.
<b>NOTE:</b> Throttle pedal in high idle position.		
Between pin 1 and 6 at pedal	$1000 \pm 400$ ohms at 20° C (68° F)	Bad potentiometer.
<b>NOTE:</b> Throttle pedal in any position.		
Between pin 4 and 5 at pedal	$1200 \pm 400$ ohms at 20° C (68° F)	Bad potentiometer.

<b>39 – Pilot Control Switch</b>		
Located on steering column pedestal.		
<b>Check Points</b>	<b>Correct Reading</b>	<b>Possible Cause of Bad Reading</b>
Terminal for wire 0B1 to ground	Continuity	Bad ground circuit.
<b>NOTE:</b> Put the master disconnect switch and the ignition switch in the ON position.		
Terminal for wire 19C to ground	24 volts	Bad fuse ECA-F1, also check circuit 19C.
<b>NOTE:</b> Press pilot control switch to turn ON switch LED.		
Terminal for wire 31L to ground	24 volts	Bad pilot control switch.
<b>NOTE:</b> Put the driving lamp switch (95) in position 3.		
Terminal for wire 49-N to ground	24 volts	Check driving lamp switch (95) and fuse ECC-F3. Also check circuit 49.
<b>NOTE:</b> If the readings are correct replace the pilot control switch.		

<b>40 – Ride Control Solenoid</b>		
Located on ride control valve inside of front frame.		
<b>Check Points</b>	<b>Correct Reading</b>	<b>Possible Cause of Bad Reading</b>
<b>NOTE:</b> Disconnect connector YRC from ride control solenoid.		
Connector YRC pin 2 to ground	Continuity	Bad ground circuit.
Between terminals 1 and 2 of ride control solenoid	20 to 26 ohms	Bad ride control solenoid.

<b>41 – Rollback Pressure Switch (Option)</b>		
Located inside of front frame.		
<b>Check Points</b>	<b>Correct Reading</b>	<b>Possible Cause of Bad Reading</b>
<b>NOTE:</b> Switch opens at 6.2 bar (90 psi). Release all hydraulic pressure from the system, disconnect the wiring harness from the rollback pressure switch.		
Between terminals A and B on switch	Continuity	Bad rollback pressure switch.
Terminal for wire 58S to ground	37 to 43 ohms	Bad ride control solenoid (40).
<b>NOTE:</b> Put the master disconnect switch and the ignition switch in the ON position. Put the ride control switch (35) in the ON position. Accelerate the machine to at least 5 km/hr (3 m.p.h.).		
Terminal for wire 58-B to ground	24 volts at 5 km/hr (3 m.p.h.)	Bad ride control relay (36) or ride control switch (35). Also check circuit 58.

**70 – Switch Pad**

Located on steering column.

Check Points	Correct Reading	Possible Cause of Bad Reading
<b>NOTE:</b> <i>Disconnect switch pad connector, put master disconnect switch and ignition switch in ON position.</i>		
Terminal for wire 17P-A to ground.	24 volts	Bad instrument cluster (62).
<b>NOTE:</b> <i>Disconnect instrument cluster connector 1.</i>		
Between terminals for wire 17P-A	Continuity	Bad wire 17P-A.

<b>86 – Right Hand Front Work Lamp</b>		
Located on right front side of cab.		
<b>Check Points</b>	<b>Correct Reading</b>	<b>Possible Cause of Bad Reading</b>
<b>NOTE:</b> <i>Disconnect wiring harness connector LRFW from RH front work lamp connector.</i>		
Flood lamp connector pin A to pin B	Continuity	Bad lamp bulb.
<b>NOTE:</b> <i>Connect wiring harness connector LRFW to RH front work lamp connector.</i>		
Terminal for wire 0-MJ to ground	Continuity	Bad ground circuit.
<b>NOTE:</b> <i>Put master disconnect switch in ON position. Put driving lamp switch (95) in position 3.</i>		
Terminal for wire 42C-G to ground	24 volts	Check fuse ECB-F1 and driving lamp switch (95). Also check circuit 42C from flood lamp to lamp switch (95) and wire 42-A to fuse ECC-F2.

<b>87 – Left Hand Rear Work Lamp</b>		
Located on left rear side of cab.		
<b>Check Points</b>	<b>Correct Reading</b>	<b>Possible Cause of Bad Reading</b>
<b>NOTE:</b> <i>Disconnect wiring harness connector LLRW from LH rear work lamp connector.</i>		
Flood lamp connector pin A to pin B	Continuity	Bad lamp bulb.
<b>NOTE:</b> <i>Connect wiring harness connector LLRW to LH rear work lamp connector.</i>		
Terminal for wire 0-ME to ground	Continuity	Bad ground circuit.
<b>NOTE:</b> <i>Put master disconnect switch in ON position. Put driving lamp switch (95) in position 4 or 5.</i>		
Terminal for wire 42R-H to ground	24 volts	Check fuse ECB-F2 and driving lamp switch (95). Also check circuit 42R from flood lamp to lamp switch (95) and wire 42-B to fuse ECC-F2.

<b>88 – Right Hand Rear Work Lamp</b>		
Located on right rear side of cab.		
<b>Check Points</b>	<b>Correct Reading</b>	<b>Possible Cause of Bad Reading</b>
<b>NOTE:</b> <i>Disconnect wiring harness connector LRRW from RH rear work lamp connector.</i>		
Flood lamp connector pin A to pin B	Continuity	Bad lamp bulb.
<b>NOTE:</b> <i>Connect wiring harness connector LRRW to RH rear work lamp connector.</i>		
Terminal for wire 0-MF to ground	Continuity	Bad ground circuit.
<b>NOTE:</b> <i>Put master disconnect switch in ON position. Put driving lamp switch (95) in position 3.</i>		
Terminal for wire 42R-G to ground	24 volts	Check fuse ECB-F2 and driving lamp switch (95). Also check circuit 42R from flood lamp to lamp switch (95) and wire 42-B to fuse ECC-F2.

**98 – Horn Relay**

Located in the cab access panel for fuses and relays.

Check Points	Correct Reading	Possible Cause of Bad Reading
Terminal for wire 19U-A to ground	24 volts	Check fuse ECC-F6, also check wire 19U-A.
Terminal for wire 19U-E to ground	24 volts	Check wire 19U-E.
Terminal for wire 64C to ground	24 volts	Bad horn relay.
<b>NOTE:</b> <i>Have another person push and hold the horn switch.</i>		
Terminal for wire 64C to ground	0 volt	Bad horn switch.
Terminal for wire 64-A to ground	24 volts	Bad horn relay.

**99 – Horn**

Located on the left front of the machine with combination lamps.

Check Points	Correct Reading	Possible Cause of Bad Reading
Terminal for wire 0-AF to ground	Continuity	Bad ground circuit.
<b>NOTE:</b> <i>Disconnect the wire 64 from the horn. Have an assistant push and hold the horn switch.</i>		
Terminal for wire 64 to ground.	24 volts	Check the horn relay (98). Also check wires 64 and 64-A.
<b>NOTE:</b> <i>If the readings are good replace the horn.</i>		

<b>108 – Front Wiper and Washer Switch</b>		
Located on right side console.		
<b>Check Points</b>	<b>Correct Reading</b>	<b>Possible Cause of Bad Reading</b>
Terminal for wire 0-DT to ground	Continuity	Bad ground circuit.
<b>NOTE:</b> Put the master disconnect switch and the ignition switch in the ON position. Make sure the front wiper and washer switch is in the OFF position.		
Terminal for wire 19J-B to ground	24 volts	Check fuse ECA-F12, check circuit 19J, also check power relay module D (21).
<b>NOTE:</b> Put the front wiper and washer switch in the LOW position.		
Terminal for wire 63LC to ground	Continuity	Bad front wiper and washer switch also check grounding circuit.
<b>NOTE:</b> Put the front wiper and washer switch in the HIGH position.		
Terminal for wire 63HC to ground	Continuity	Bad front wiper and washer switch also check grounding circuit.
<b>NOTE:</b> Put the front wiper and washer switch in the wash position.		
Terminal for wire 63W to ground	24 volts	Bad front wiper and washer switch.

## RADIO AND POWER CONVERTER

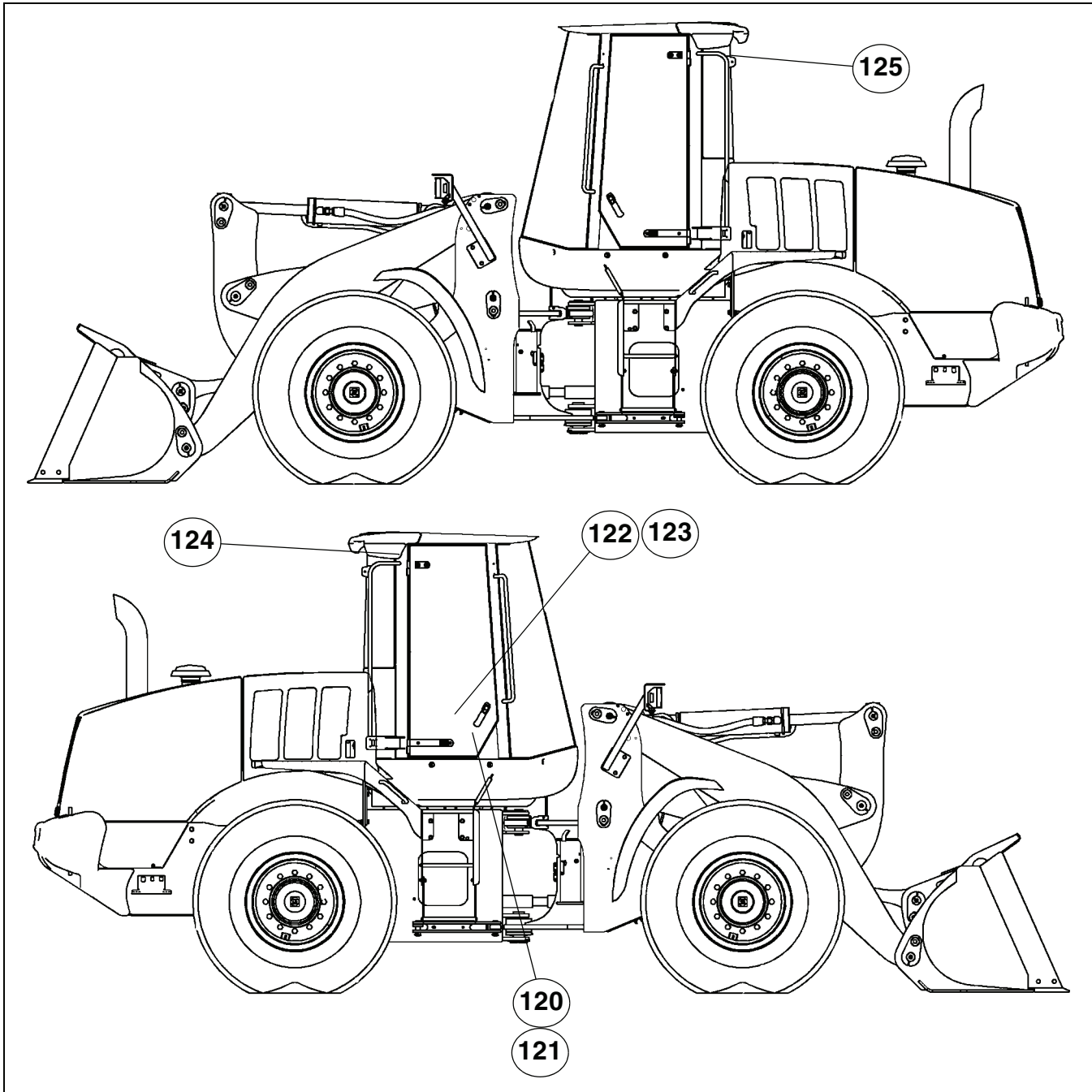

BS06H241 / BS06H242

120.POWER RELAY MODULE E

121.POWER CONVERTER 24 TO 12 VOLT

122.12 VOLT POWER OUTLETS (OPTION)

123.RADIO

124.RIGHT SPEAKER

125.LEFT SPEAKER

**NOTE:** The battery must be at full charge and all connections clean and tight before doing any testing of the electrical system. Use a Multimeter for the following tests.

<b>140 – Water Valve Potentiometer</b>		
<b>Check Points</b>	<b>Correct Reading</b>	<b>Possible Cause of Bad Reading</b>
<b>NOTE:</b> <i>Put the master disconnect switch and the ignition switch in the ON position. Take reading between pins on potentiometer.</i>		
Place potentiometer in maximum heat position	4 volts	Bad potentiometer
Place potentiometer in mid range position	2.5 volts	Bad potentiometer
Place potentiometer in maximum cool position	0 volts	Bad potentiometer
<b>NOTE:</b> <i>If no voltage is present at potentiometer check the driver (132).</i>		

<b>141 – Air Recirculating Switch</b>		
<b>Check Points</b>	<b>Correct Reading</b>	<b>Possible Cause of Bad Reading</b>
<b>NOTE:</b> <i>Disconnect connector from the switch. Place switch in outside air position.</i>		
Between terminals on switch	Continuity	Bad recirculating switch.
<b>NOTE:</b> <i>Place switch in recirculate air position.</i>		
Between terminals on switch	Open	Bad recirculating switch.

**CONNECTOR DNS-RESISTOR**

**ART NOT AVAILABLE**

CAV	WIRE IDENT	CIRCUIT
1	DNS61	
2	DNS62	
3	DNS63	
4	DNS64	
5	Not used	

**CONNECTOR DNS-ELECT-WATER-VALVE-S**

**ART NOT AVAILABLE**

CAV	WIRE IDENT	CIRCUIT
1	DNS60	
2	Not used	
3	DNS56	
4	DNS57	
5	DNS58	
6	DNS59	

**CONNECTOR DNS-DRIVER**

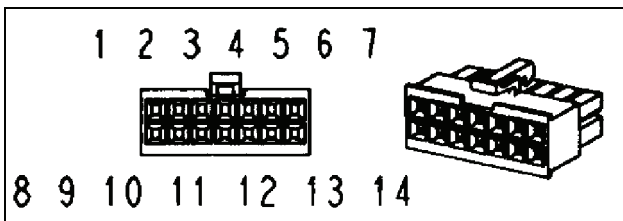

411311A1

CAV	WIRE IDENT	CIRCUIT
2	DNS50	
3	DNS52	
4	DNS49	
5	DNS48	
6	DNS55	
7	DNS57	
8	DNS58	
9	DNS59	
11	DNS51	
12	DNS53	
13	DNS54	
14	DNS56	

**CONNECTOR DNS-HVAC1-S**

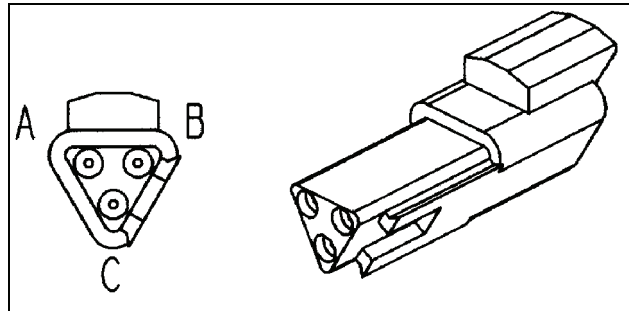

225294C1

CAV	WIRE IDENT	CIRCUIT
A	DNS67	
B	DNS76	
C	DNS69	

**CONNECTOR DNS-HVAC2-S**

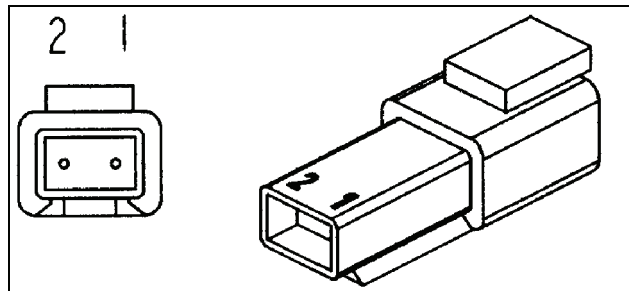

225315C1

CAV	WIRE IDENT	CIRCUIT
1	DNS74	
2	DNS75	

**CONNECTOR DS - DOOR SWITCH**

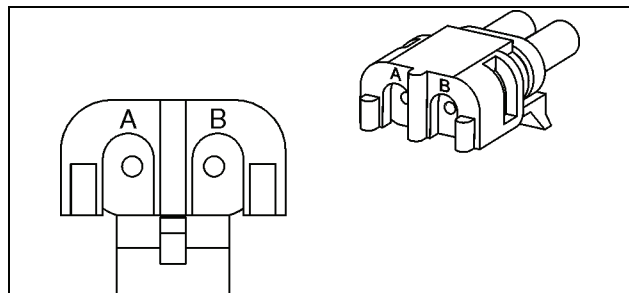

245482C1

CAV	WIRE IDENT	CIRCUIT
A	19U-F	Door Switch Fused Power
B	43S-B	Door Open Signal

**CONNECTOR GND-CAB-SPL - CAB GROUND SPLICE**

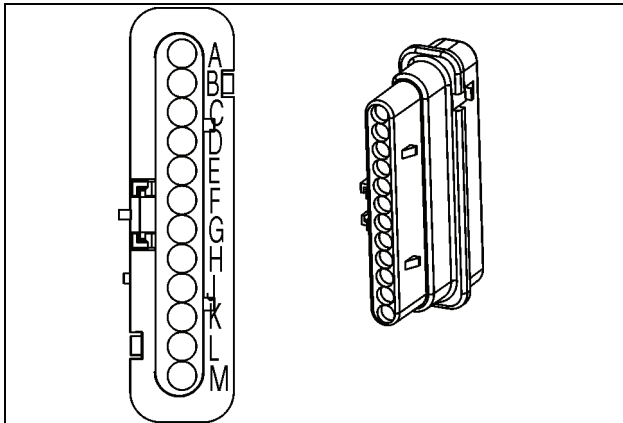

87324393

CAV	WIRE IDENT	CIRCUIT
A	0-EE	Diode Suppression Grounds
B	0-EM	Radio Ground
C	0-EP	Horn Switch Ground
D		Not Used
E		Not Used
F	0-DG	Cab Splice Grounds
G	0-DT	Front Wiper/Washer Sw Gnd
H	0-DL	Power Converter Relay Ctrl Gnd
I	0-DK	Seat Compressor Motor Ground
K	0-DJ	AC Relay Control Ground
L	0-DU	Pilot Pressure Solenoid Gnd
M	0-DH	Diagnostic Connector Ground

**CONNECTOR GND-CAB-SPL2 - SPLICE BACK LIGHT GROUND**

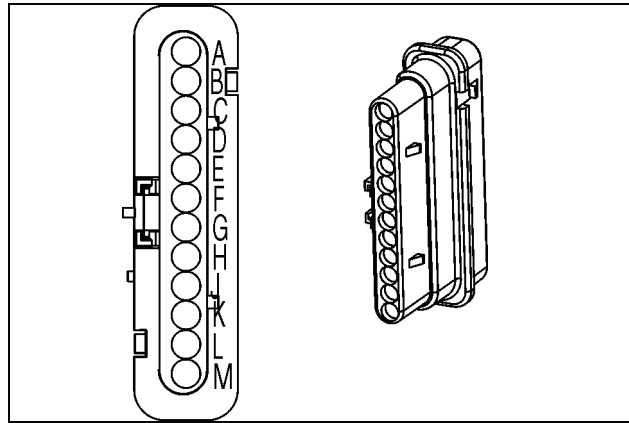

87324393

CAV	WIRE IDENT	CIRCUIT
A	0-DC	Time Delay Module Ground
B	0-EA	Time Delay Relay Control Gnd
C	0-EB	Ignition Relay Control Ground
D	0-EC	ACC Relay Control Ground
E	0-DD	Voltmeter Relay Control Gnd
F	0-DF	Crank Request Relay Control Gnd
G	0-DE	Neutral Start Relay Control Gnd
H	0-EQ	Splice Pack Gnd Cab SPL2 GND
J		Not Used
K	0-EH	Flasher Module Ground
L	0-EG	Flasher Module Ground
M	0-EF	Brake Lights Relay Control Gnd

**CONNECTOR HD-NT1 - HOOD TO ENGINE**

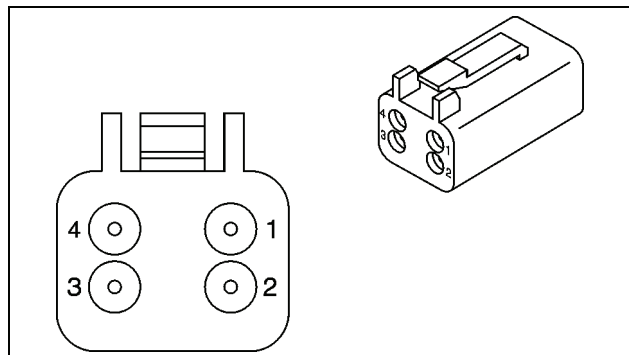

239451A1

CAV	WIRE IDENT	CIRCUIT
1	0-JA-T	Hood Grounds(NA)
2	44A-ET	Brake Light Relay Out
3	45L-BT	Left Turn Signal
4	45R-BT	Right Turn Signal

**CONNECTOR PXF - RTD**

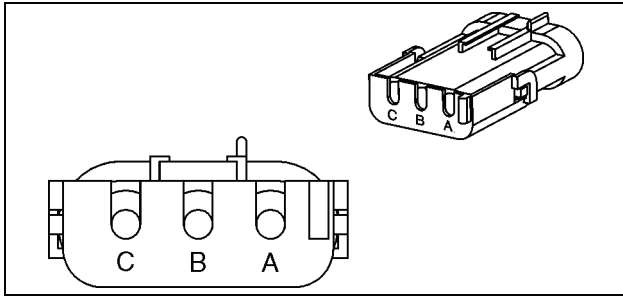

245485C1

CAV	WIRE IDENT	CIRCUIT
A	53B	RTD Signal
B	0-AC	Proximity Switch Ground
C	53P-H	Pilot Control Relay Out

**CONNECTOR PXT - RTD**

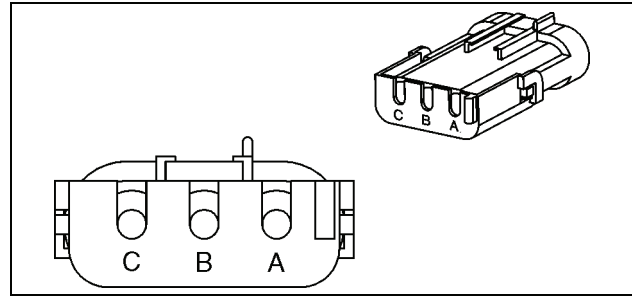

245485C1

CAV	WIRE IDENT	CIRCUIT
A	53B-A	RTD Control Signal
B	0-AM	RTD Ground
C	53P-I	Pilot Control Relay Out

**CONNECTOR PXH - HEIGHT CONTROL RTT**

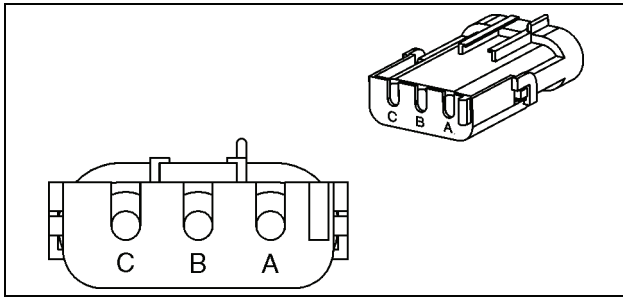

245485C1

CAV	WIRE IDENT	CIRCUIT
A	54B	RTT Signal
B	0-AA	Proximity Switch Ground
C	53P-J	Pilot Control Relay Out

**CONNECTOR RAD - RADIO POWER**

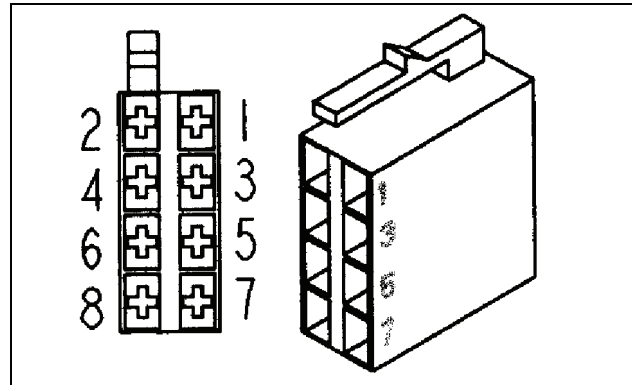

292495A1

CAV	WIRE IDENT	CIRCUIT
1		Not Used
2		Not Used
3		Not Used
4	12V-HB	12V Fused Power to Radio
5		Not Used
6		Not Used
7	12V-HA	12V Fused Power to Radio
8	0-EN	Radio Ground

**CONNECTOR PXM - RTD**

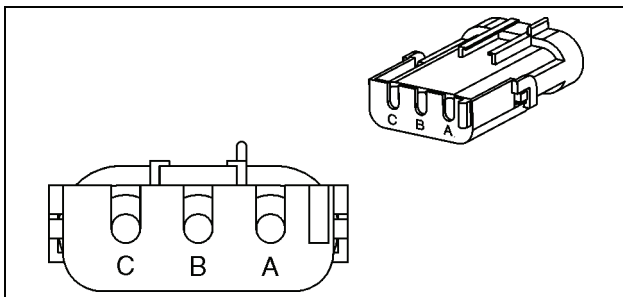

245485C1

CAV	WIRE IDENT	CIRCUIT
A	53B-A	RTD Control Signal
B	0-AM	RTD Ground
C	53P-I	Pilot Control Relay Out

**CONNECTOR SPL-ENG-GND - GROUND SPLICE  
6 PACK**

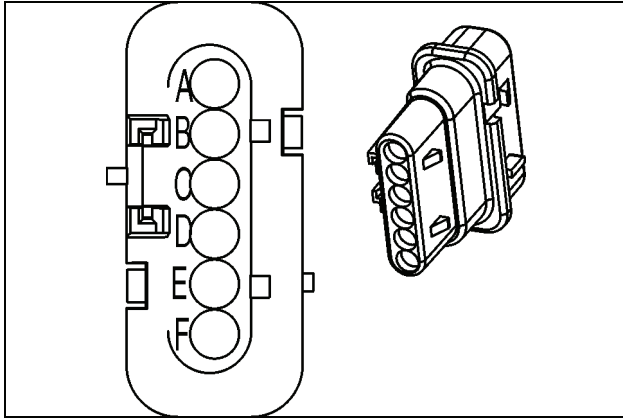

87324391

CAV	WIRE IDENT	CIRCUIT
A	0-BM	Engine Splice Grounds
B	0-BY	Air Filter Restriction Switch Gnd
C		Not Used
D	0-BS	Fan Control Ground
E	0-B	Front Washer Ground
F	0-BL	Rear Washer Ground

**CONNECTOR SPL-PED-BL - SPL BACK LIGHT  
POWER 6 PACK**

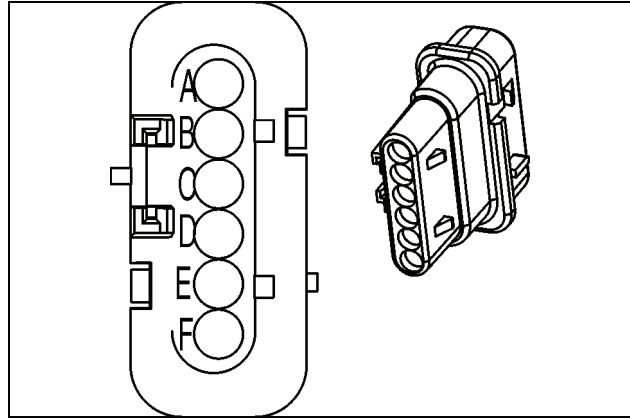

87324391

CAV	WIRE IDENT	CIRCUIT
A	49-U	Back Light Power
B	49-N	Back Light Power
C	49-D	Back Light Power
D	49U	Back Light Power
E	49-V	Back Light Power
F	49-S	Back Light Power

**CONNECTOR SPL-HOOD-GND - HOOD GROUND  
6 PACK**

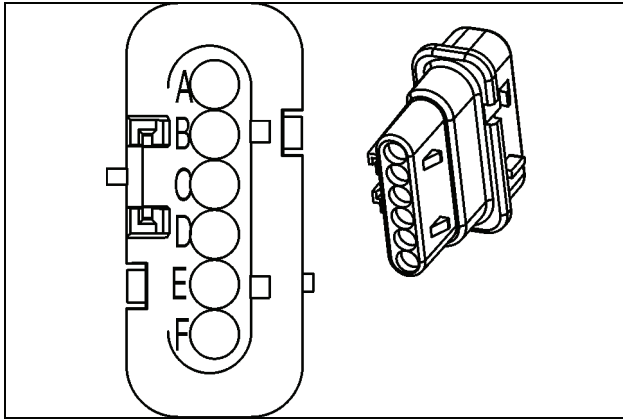

87324391

CAV	WIRE IDENT	CIRCUIT
A	0-B12	Hood Down Relay Ground
B	0-B16	Hood Down Control Ground
C	0-B22	Hood Up Relay Ground
D	0-B25	Hood Up Control Ground
E	0-B10	Hood Ground
F		Not Used

**CONNECTOR SPL-PED-BL-GD - SPL BACK  
LIGHT GROUND 6 PACK**

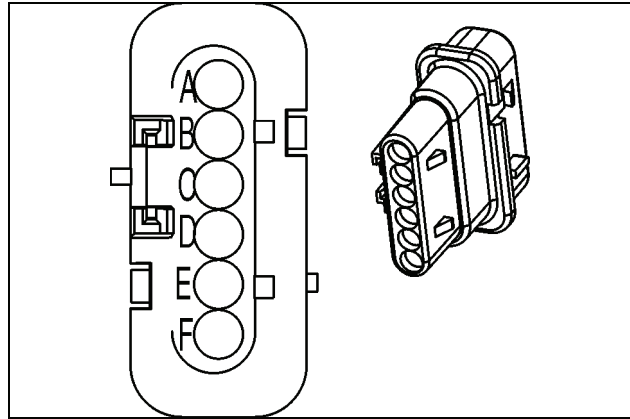

87324391

CAV	WIRE IDENT	CIRCUIT
A	0-B9	Back Light Ground
B	0-B1	Back Light Ground
C	0-B24	Back Light Ground
D	0-B30	Back Light Ground
E	0-B29	RTT/Float Ground
F	0-B11	Back Light Ground

**CONNECTOR TRC - TRANSMISSION CONTROL**

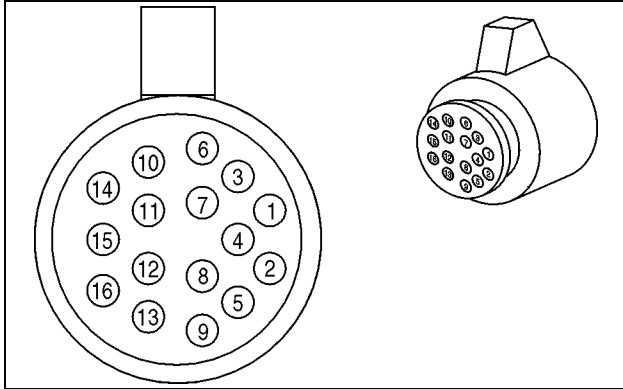

371566A1

CAV	WIRE IDENT	CIRCUIT
1	25K	Trans Solenoid Valve Y1
1	25L-9	Trans Solenoid Valve Y1
2	25K-9	Trans Solenoid Valve Y2
2	25L	Trans Solenoid Valve Y2
3	25M	Trans Solenoid Valve Y3
4	25N	Trans Solenoid Valve Y4
5	25P	Trans Solenoid Valve Y5
6	25J	Trans Solenoid Valve Y6
7	25S	Output Sw Power VPS1
8	36T	Valve Body Temp Signal
9	36R-C	Valve Body Temp Return
10		Not Used
11		Not Used
12		Not Used
13		Not Used
14		Not Used
15		Not Used
16		Not Used

**CONNECTOR TS1 - TRANSMISSION SHIFTER**

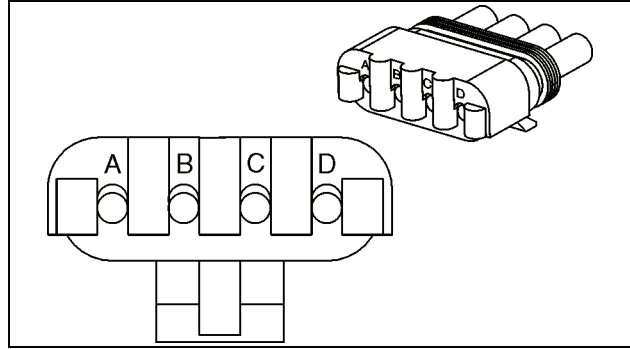

245486C1

CAV	WIRE IDENT	CIRCUIT
A	19A-H	Trans Shifter Fused Power
B	25F	Forward Signal
C	25R	Reverse Signal
D	25T-B	Neutral Signal

**CONNECTOR TS2 - TRANSMISSION SHIFTER**

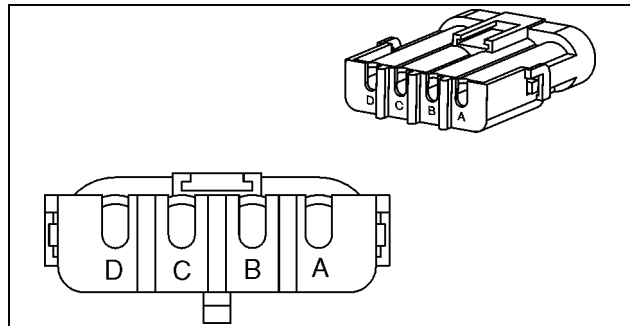

245487C1

CAV	WIRE IDENT	CIRCUIT
A		Not Used
B	25W	3rd and 4th Gear Signal
C	25Z	1st and 4th Gear Signal
D	25Y	Transmission Kick Down Signal

## TABLE OF CONTENTS

SAFETY RULES .....	3
SPECIAL TOOLS .....	3
MAINTENANCE .....	4
Electrolyte Level .....	4
Inspecting and Cleaning a Battery .....	4
BATTERY TEST .....	5
Visual Checks .....	5
Specific Gravity Check .....	5
Capacity (Load) Test .....	6
CHARGING A BATTERY .....	7
Charging Guide For Maintenance Free Batteries .....	7
Charging Guide For Batteries Other Than Maintenance Free Batteries .....	8
PREPARING A DRY CHARGED BATTERY FOR USE .....	8

## Self-Test

1. Turn the ignition (key) switch to the ON position.
2. The instrument cluster will automatically check each monitored system.
3. All LED's (Light Emitting Diodes) will illuminate for 2 - 3 seconds.
4. Four gauges will energize for 2 - 3 seconds.
5. The warning alarm will sound for 2 - 3 seconds.
6. If there is an open circuit between a sensor and the instrument cluster, the LED will flash and the warning alarm will sound for 5 seconds.
7. If there were no faults detected during the check, all monitored systems will return to normal operation.
8. If only some of the LEDs illuminate, replace the instrument cluster.
9. If the LEDs illuminate, but the warning alarm does not sound, see section 4002 and test the alarm circuit.
10. If the warning alarm sounds but the LEDs do not illuminate, if no power is present at buzzer, replace the instrument cluster, if power is present at the buzzer, replace the buzzer.
11. If the warning alarm does not sound and the LEDs do not illuminate on the instrument cluster, do the following steps to test the power circuit:

## Power Circuit Test

- A. Check fuse ECA-F3. If the fuse is bad, replace the fuse and repeat Self-Test. If the fuse is good, go to next step.
- B. Check wire 19EA for continuity. Repair/replace the wire as required. If continuity is found go to next step.
- C. Check power relay module A for proper operation, see Section 4002. If the power relay module checks good, go to next step.
- D. Check the ignition switch for proper operation, see Section 4002. If the ignition switch checks good, go to next step.
- E. Check fuse ECC-F5. If the fuse is bad, replace the fuse.

## RETRIEVING FAULT CODES

### General Fault Code Identification

1. Press and hold the escape key and up arrow key for more than 2 seconds to access the fault codes.

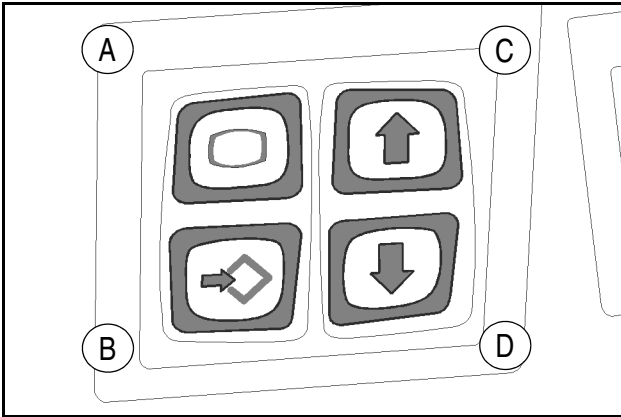

BD06H037-01

- A. Escape key
  - B. enter key
  - C. up key
  - D. down key
2. Yellow Faults, buzzer will beep once every 2 seconds:
    - A. Operator can acknowledge it by pressing the enter key.
    - B. The message will disappear.
    - C. Buzzer will not beep anymore.
    - D. Yellow lamp will stay ON.
    - E. Fault will remain in Yellow list until it is closed.
  3. Red Faults, buzzer will be continuous, alternating sounds:
    - A. Operator can acknowledge it by pressing the enter key.
    - B. Buzzer will change to a less stressing sound, but will remain.
    - C. Message will remain on display with indication of URGENT STOP.

### Fault Code Display

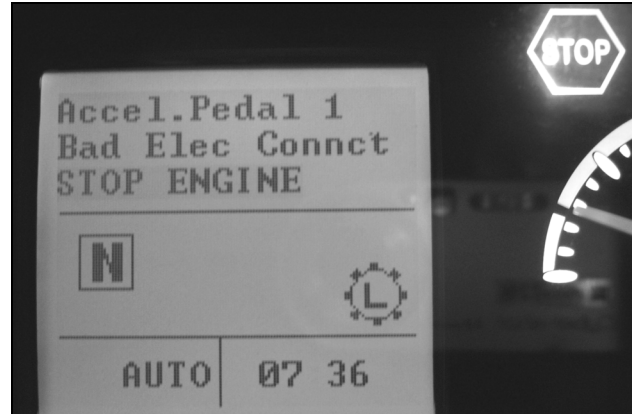

BD07C010

1. If a fault code occurs, it will be displayed in the upper zone of the LCD. Depending on how critical the code is, the RED master STOP or the YELLOW caution indicator will also come on.

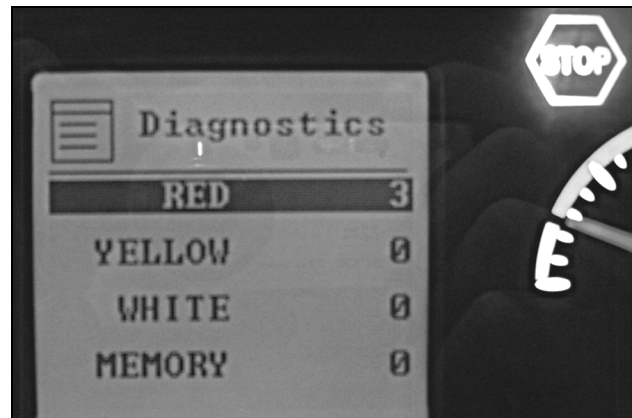

BD07C011

2. To retrieve the code/s, press the two upper buttons of the keypad for 2 seconds. When the screen comes up press ENTER on the category with codes present.

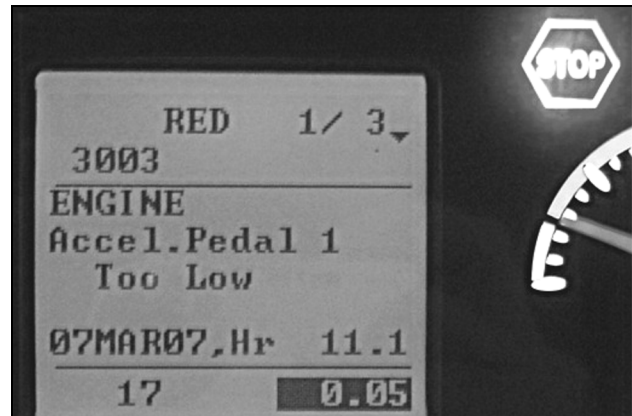

BD07C012

3. If more than one code is present in the category, scroll through to each by pressing the DOWN button on the keypad.

CODE	DEFINITION	DESCRIPTION AND POSSIBLE STEPS FOR REPAIR
3245	Communication supervision watchdog control flag	Defective monitoring module or CPU (e.g. impaired functioning of the CPU clock) of the EDC. Disturbed SPI-Bus. If error exists only temporary (i.e. injection reoccurs) error can be ignored and error deleted in the fault memory. In case of a permanent error the injection remains blocked and the ECU has to be replaced
3246	Redundant shutoff paths during initial	Watch dog switch off path defect. If failure remains after ECU initialization: replace ECU
3247	Redundant shutoff paths during initial	Electronic disturbances, internal ECU problem. If failure remains after ECU initialization: replace ECU
3248	Redundant shutoff paths during initial	
3253	Error status ADC monitoring	Buffer overrun No additional information available at time of print
3254	Error status ADC monitoring	
3255	Error status ADC monitoring	
3256	Error status ADC monitoring	
3258	Short-circuit to battery at high side power stage	Short circuit of wiring to external source or inside relay. Check wiring or replace relay
3259	Short-circuit to ground at high side power stage	Short circuit of wiring to ground or inside relay. Check of wiring or replace relay
3260	Open load at low side power stage	Broken or disconnected wiring or defective relay. Check wiring or replace relay
3261	Short-circuit to battery or excessive temperature at low side power stage	Short circuit of wiring to external source or inside relay. Check wiring or replace relay
3262	Short-circuit to ground at low side power stage	Short circuit of wiring to ground or inside relay. Check wiring or replace relay
3265	Energizing time exceeds limit of over run monitoring	Electronic disturbances, requested torque increase via tester, wrong application of injection relevant parameters, defective ECU. Check injection relevant application, if failure persists replace ECU
3266	Plausibility error in engine speed check	Electronic disturbances, internal ECU problem. If failure persists after reinstallation replace ECU
3278	Supply voltage CJ940 upper limit	Excessive voltage supply of a CJ940 component: High battery voltage, defective wiring, internal defect of the EDC. Check the battery for correct voltage supply, check wiring. If defect remains replace EDC (internal defect)

## TABLE OF CONTENTS

STEERING CONTROL VALVE .....	3
Removal .....	3
Installation .....	4
AUXILIARY STEERING PRIORITY VALVE .....	6
Removal .....	6
Installation .....	6
AUXILIARY STEERING PUMP AND MOTOR .....	8
Removal .....	8
Installation .....	8
STEERING CYLINDER .....	10
Removal .....	10
Installation .....	10
STEERING BACK PRESSURE VALVE .....	12
Removal .....	12
Installation .....	12

## STEERING BACK PRESSURE VALVE

### Removal

1. Remove the fill cap for the hydraulic reservoir to release pressure in the reservoir, attach a vacuum pump to the reservoir, start the pump.
2. Disconnect hoses (2) and (5) from the pressure relief valve.
3. Remove the nuts, bolts and spacers from the pressure relief valve, remove the valve from the machine.

### Installation

1. Install the valve, bolts, spacers and nuts onto the machine, tighten the bolts.
2. Install new O-rings onto the fittings of the hoses, install and tighten the hoses.
3. Stop the vacuum pump, install and tighten the reservoir filler cap.
4. Start and run the machine at low idle, turn the steering wheel from full left lock to full right lock holding the steering over relief.
5. Stop the machine and check for leaks.
6. Check fluid level in hydraulic reservoir. Add oil as required. See Section 1002 for specifications.

6. Make sure that the temperature of the hydraulic oil is at least 52° C (125° F).
7. To measure the temperature of the oil using the instrument panel:
  - A. Press the program switch (left side of the program/reset switch).
  - B. Press the up count switch to function 008.
  - C. Return the program switch to the **OFF** (center) position.
8. Apply the parking brake.
9. Start and run the engine at full throttle.
10. Hold the bucket control lever in the rollback position.
11. Hold the lift lever in the "FLOAT" position.
12. Continue holding until the specified temperature of the oil is reached.
13. Stop the engine.
14. Remove the cap on the hydraulic reservoir to release any pressure in the hydraulic system.

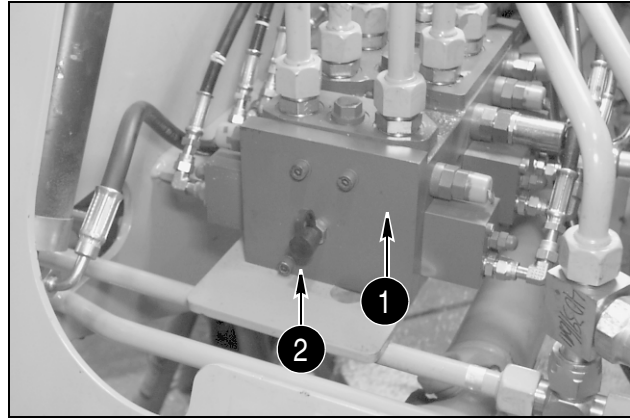

BD00N018

1. LOADER CONTROL VALVE
2. PUMP PRESSURE TEST PORT

15. Remove the dust cap from the test port (2).
  16. Connect a 345 bar (5000 psi) pressure gauge to the test port (2) on the front of the loader control valve (1).
- NOTE:** *Make sure when you connect the pressure gauge that you do so in a manner that you can read the pressure gauge while sitting in the operators seat.*
17. Start the engine and operate the machine at full throttle.
  18. With the articulation lock still in place, turn and hold the steering wheel for a hard right turn.
  19. Continue holding the steering wheel, and read the pressure gauge.
  20. The pressure gauge must indicate 239 to 243 bar (3465 to 3523 psi). If the pressure is not correct, adjust the steering relief valve.

## TABLE OF CONTENTS

SPECIFICATIONS .....	3
SPECIAL TOOLS .....	3
CENTER PIVOT .....	4
Disassembly .....	4
Assembly .....	6
CONNECTING THE FRONT FRAME TO THE REAR FRAME .....	9

## TABLE OF CONTENTS

SPECIFICATIONS .....	3
AUXILIARY STEERING MOTOR AND PUMP .....	4
Disassembly .....	4
Inspection .....	4
Assembly .....	4

## Summary table of the ON/OFF statuses

State of activation of the JSS, JSS F-N-R and auxiliary F-N-R:

Starting status	<b>JSS OFF</b>	<b>JSS OFF</b>	<b>JSS OFF</b>	<b>JSS ON</b>
	<b>JSS / AUX F-N-R disabled</b>	<b>(JSS) AUX F-N-R enabled</b>	<b>JSS / AUX F-N-R disabled</b>	<b>JSS (AUX) F-N-R enabled</b>
Activation signal	<b>JSS activation signal</b>	<b>JSS activation signal</b>	<b>Auxiliary F-N-R enabling signal</b>	<b>F-N-R enable signal or JSS enable signal</b>
JSS safety conditions to be met	<ul style="list-style-type: none"> <li>▪ Equipment locking switch disabled;</li> <li>▪ Armrest on left-hand side lowered;</li> <li>▪ Vehicle stationary;</li> <li>▪ Main F-N-R gear lever = neutral;</li> <li>▪ JSS pilot pressure less than 8 bar;</li> <li>▪ JSS Joystick = neutral;</li> <li>▪ No errors on JSS system.</li> </ul>	<ul style="list-style-type: none"> <li>▪ Equipment locking switch disenabled;</li> <li>▪ Armrest on left-hand side lowered;</li> <li>▪ Vehicle stationary;</li> <li>▪ Main F-N-R gear lever = neutral;</li> <li>▪ JSS pilot pressure less than 8 bar;</li> <li>▪ JSS Joystick = neutral;</li> <li>▪ No errors on JSS system.</li> </ul>		
<b>Resulting JSS status</b>	<ul style="list-style-type: none"> <li>▪ <b>JSS ON</b></li> </ul>	<ul style="list-style-type: none"> <li>▪ <b>JSS ON</b></li> </ul>	<ul style="list-style-type: none"> <li>▪ <b>JSS OFF</b></li> </ul>	<ul style="list-style-type: none"> <li>▪ <b>JSS ON</b></li> </ul>
F-N-R conditions	<ul style="list-style-type: none"> <li>▪ <b>JSS ON</b></li> <li>▪ JSS F-N-R = neutral.</li> </ul>	<ul style="list-style-type: none"> <li>▪ <b>JSS ON</b></li> <li>▪ JSS F-N-R = neutral.</li> </ul>	<ul style="list-style-type: none"> <li>▪ Vehicle stationary;</li> <li>▪ Main F-N-R gear lever = neutral;</li> <li>▪ AUX F-N-R = neutral.</li> </ul>	<ul style="list-style-type: none"> <li>▪ Vehicle stationary</li> <li>▪ Main F-N-R gear lever = neutral;</li> <li>▪ AUX F-N-R = neutral.</li> </ul>
<b>Resulting F-N-R status</b>	<ul style="list-style-type: none"> <li>▪ <b>JSS F-N-R Enabled</b></li> <li>▪ Stays enabled.</li> </ul>	<ul style="list-style-type: none"> <li>▪ <b>JSS F-N-R Enabled</b></li> <li>▪ Stays enabled.</li> </ul>	<ul style="list-style-type: none"> <li>▪ <b>AUX F-N-R Enabled</b></li> <li>▪ within 8 seconds release parking brake and engage F or R to maintain enabling.</li> </ul>	<ul style="list-style-type: none"> <li>▪ <b>JSS F-N-R Enabled</b></li> </ul>
F-N-R conditions not met	<ul style="list-style-type: none"> <li>▪ If JSS F-N-R not in neutral.</li> </ul>	<ul style="list-style-type: none"> <li>▪ If JSS F-N-R not in neutral.</li> </ul>	<ul style="list-style-type: none"> <li>▪ If AUX F-N-R not in neutral.</li> </ul>	
F-N-R alternative status	<ul style="list-style-type: none"> <li>▪ JSS / AUX F-N-R disabled.</li> </ul>	<ul style="list-style-type: none"> <li>▪ JSS / AUX F-N-R disabled.</li> </ul>	<ul style="list-style-type: none"> <li>▪ JSS / AUX F-N-R disabled.</li> </ul>	

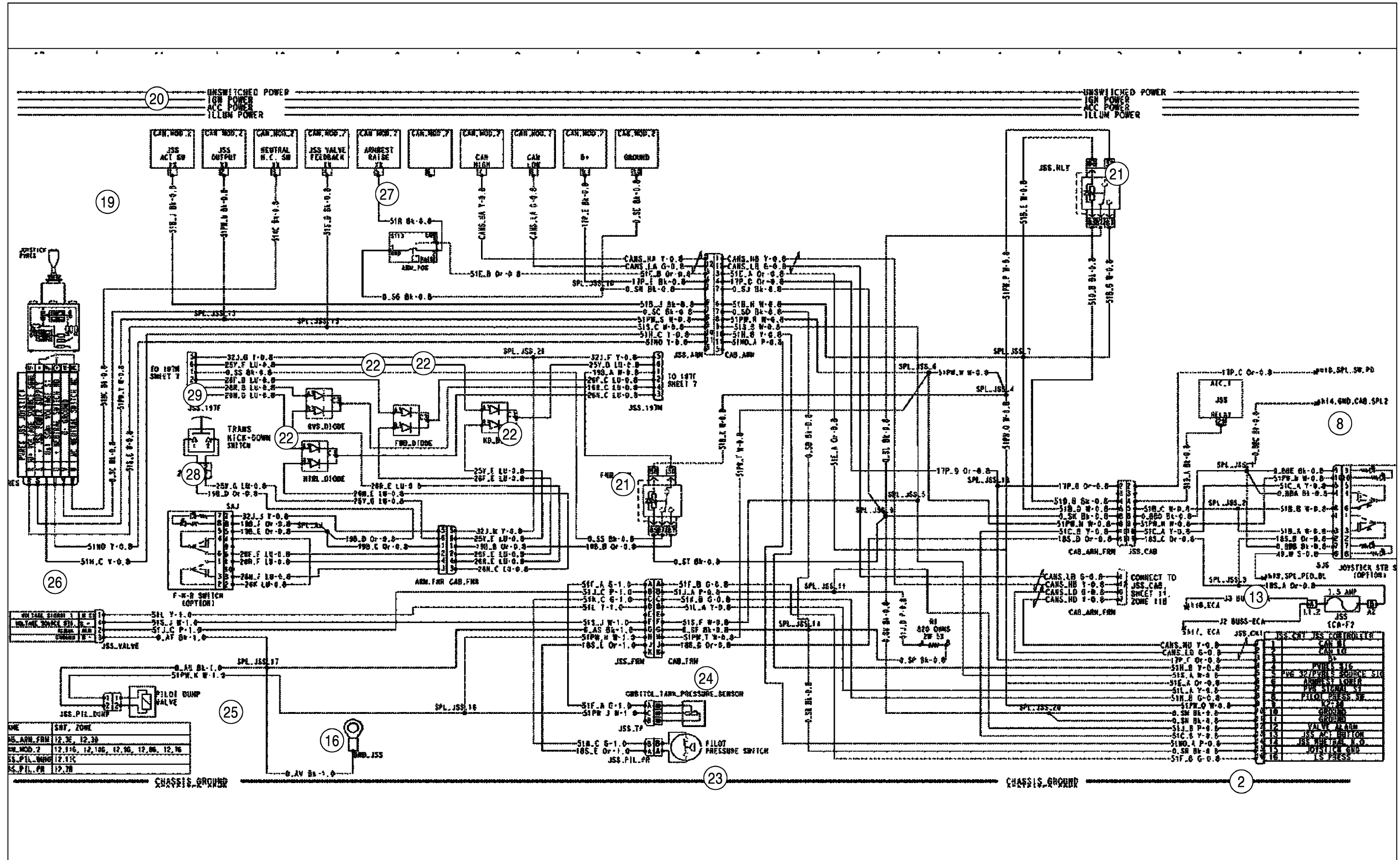

WIRING DIAGRAM OF THE JOYSTICK STEERING SYSTEM

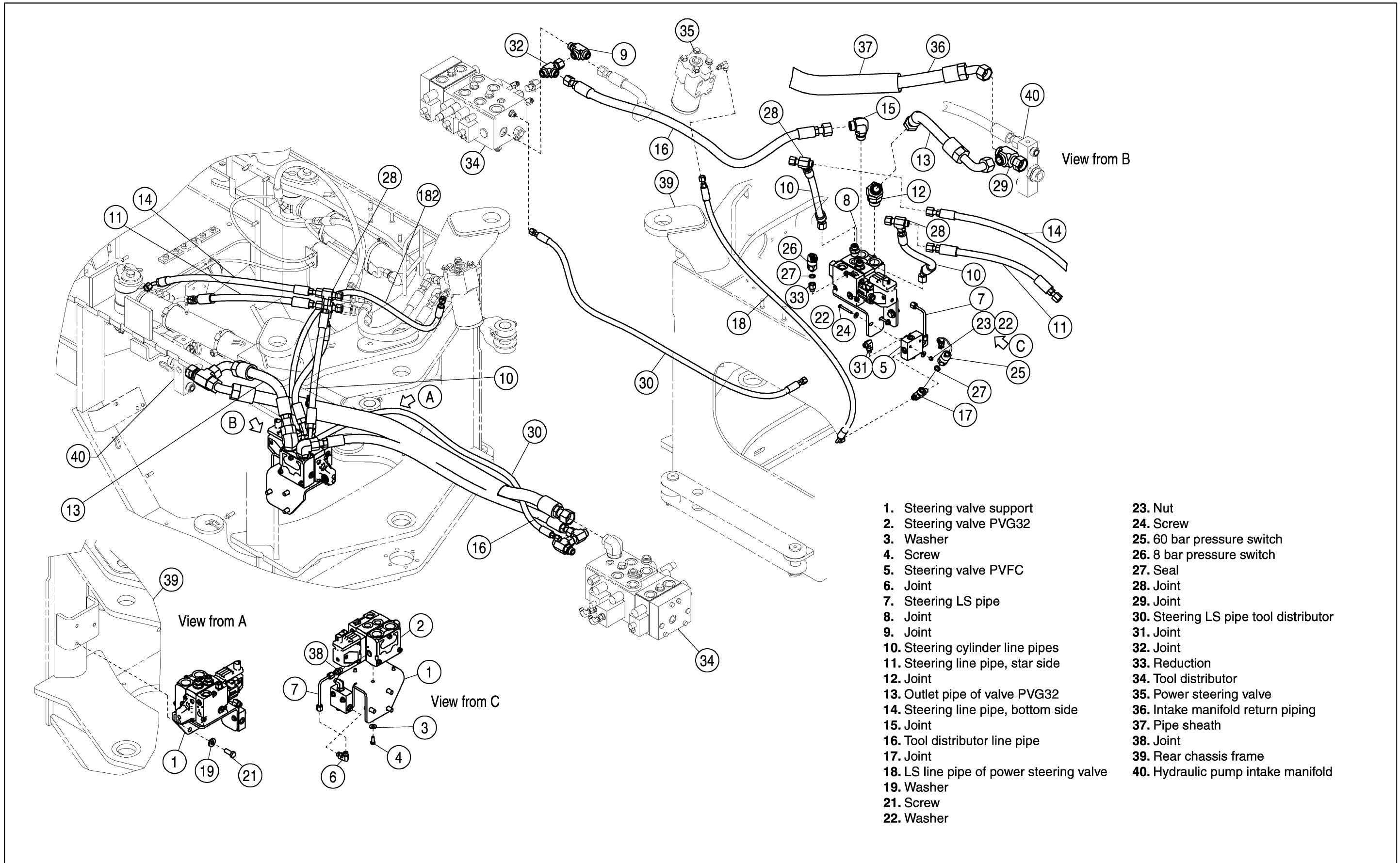

HYDRAULIC COMPONENTS OF THE JOYSTICK STEERING SYSTEM WITHOUT AUXILIARY STEERING SYSTEM

**STEP 9**

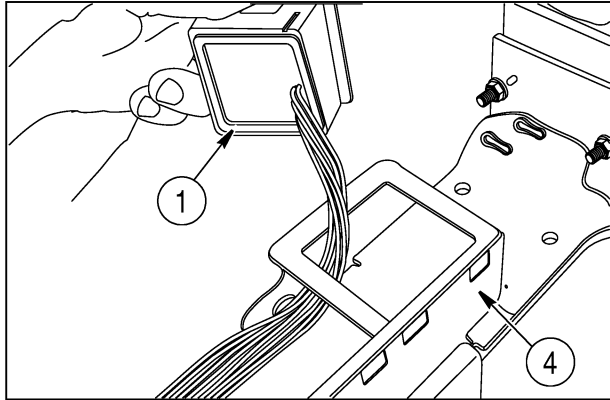

W190-4R039

Detach the CAN module (1) from the support (4).

**STEP 10**

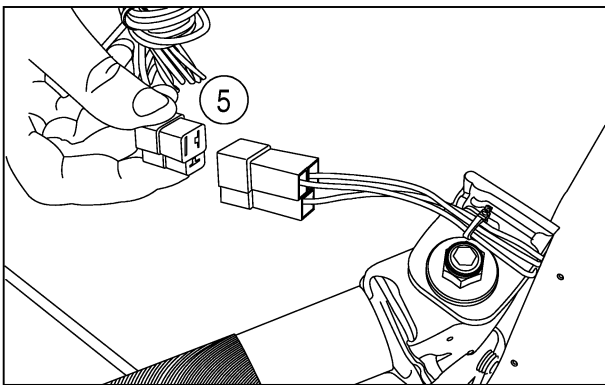

W190-4R042

Disconnect the connector (5) from the armrest positioning switch. Remove the armrest cable.

**STEP 11**

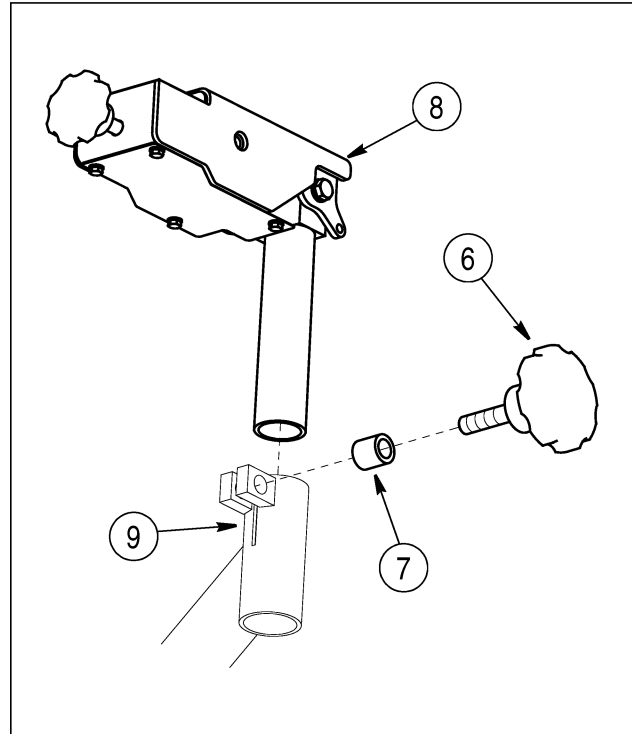

W190-4R041

Unscrew and remove the knob (6) for height adjustment of the armrest and spacer (7). Raise and extract the armrest (8) from the support (9).

**STEP 12**

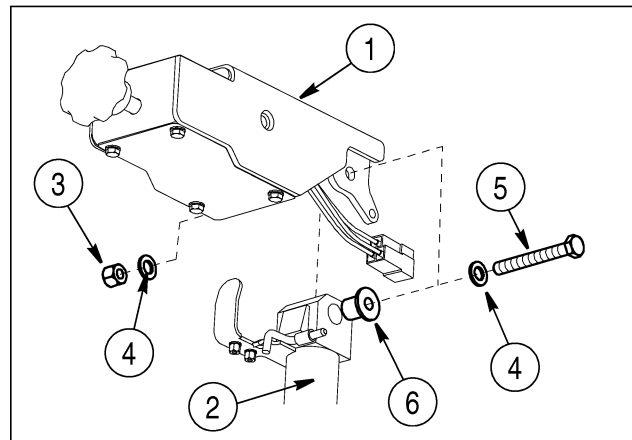

W190-4R043

Remove the armrest height / angle adjustment device (2) from the support assembly (1) by removing the nut (3) washers (4), cap screws (5) and two nylon bushings (6).

**STEP 43**

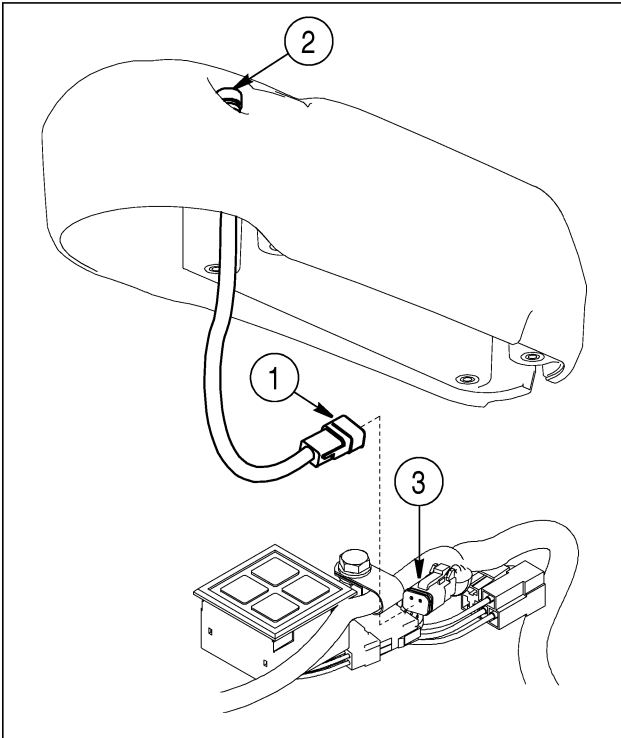

W190-4R108

Connect connector (1) of the Kick-Down button (2) with the cable (3).

**STEP 44**

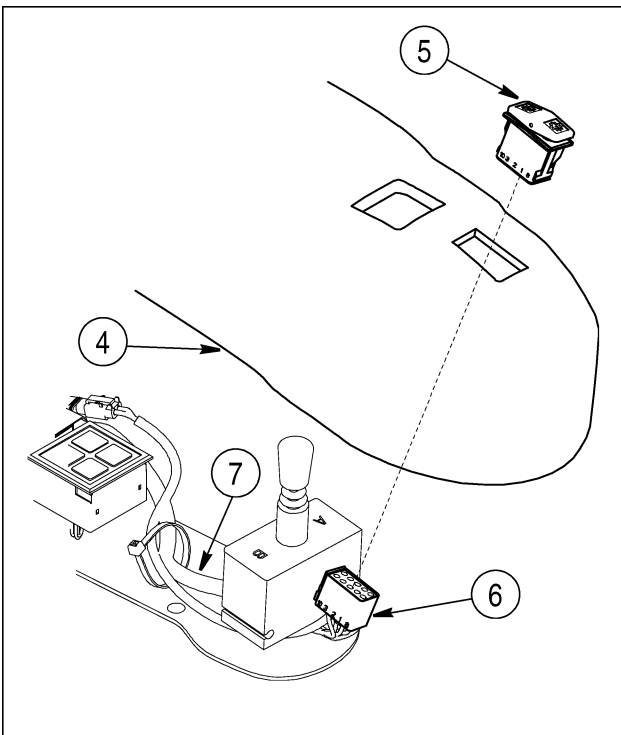

W190-4R109

Insert the "F-N-R" switch (5) in the armrest (4), connect connector (6) to cable (7).

**STEP 45**

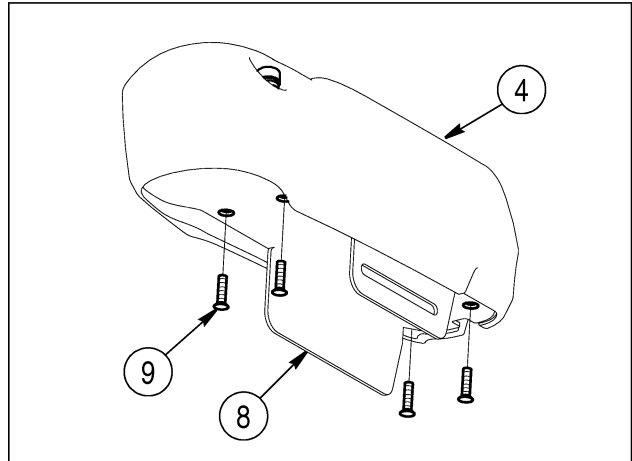

W190-4R069

Put the armrest (4) on the support (8) and secure it with the four cap screws (9).

**STEP 46**

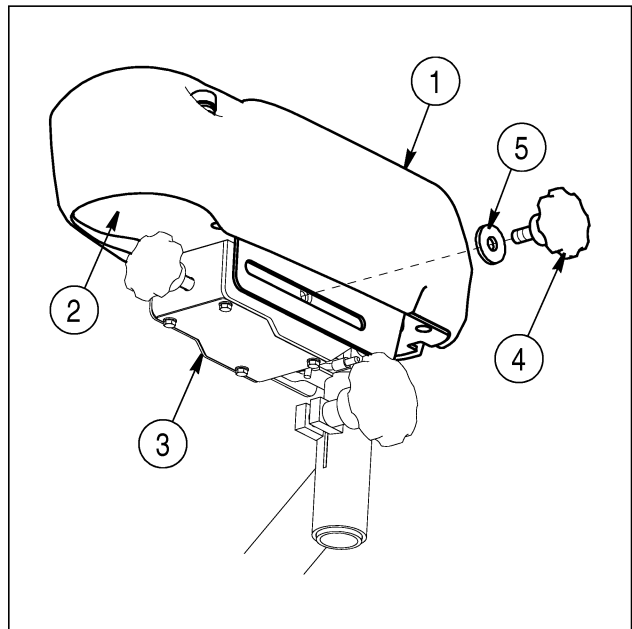

W190-4R070

Position the armrest (1) with support (2) onto the armrest adjustment (3) and install knob (4) with washer (5).

**STEP 47**

Put the battery disconnecting switch in the ON position and start the engine.

Turn the steering wheel all the way to the left and then to the right several times.

Switch off the engine. Check the hydraulic oil level. See the specific section for the specifications.

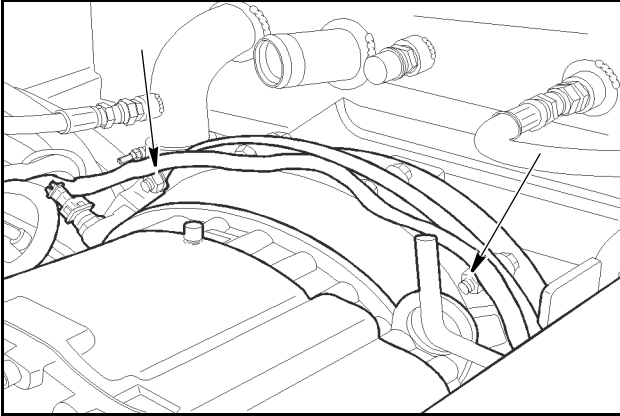
**STEP 9**

BD01D310-01

Remove two socket head bolts securing transmission wiring harness clamps.

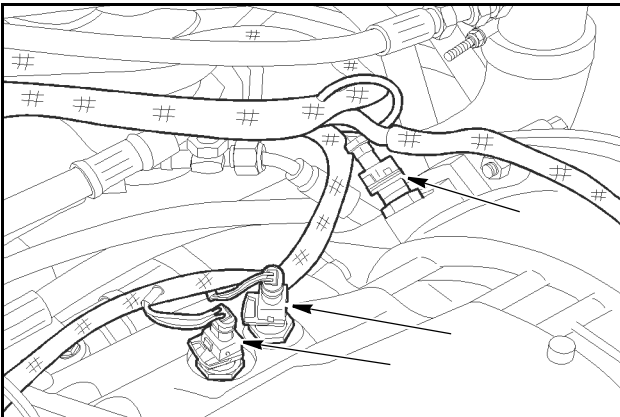
**STEP 10**

BD01D312-01

Identify, tag, and disconnect transmission wiring harness connectors from engine speed sensor, intermediate speed sensor, and turbine speed sensor. Move transmission wiring harness away from transmission.

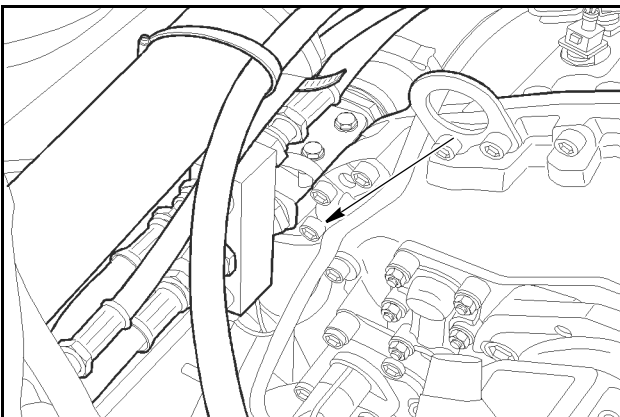
**STEP 11**

BD01D316-01

Remove socket head bolt securing wiring harness clamp. Move wiring harness away from transmission.

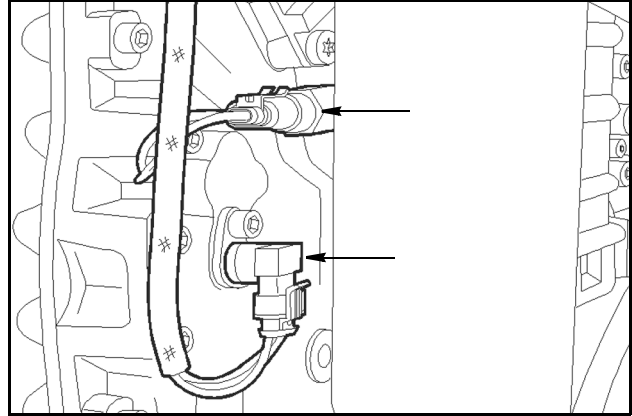
**STEP 12**

BD07N603-01

Identify, tag, and disconnect transmission wiring harness connectors from filter maintenance switch and output speed sensor. Move transmission wiring harness away from transmission.

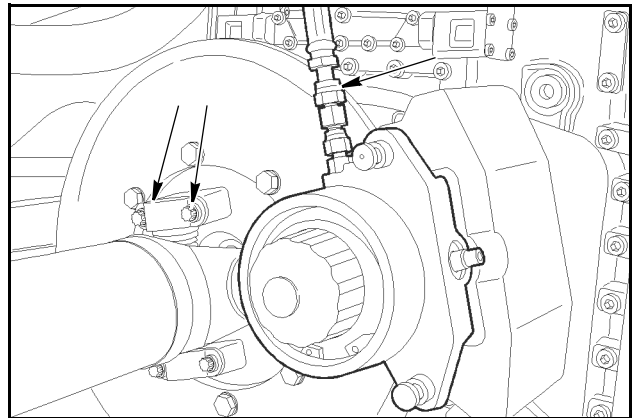
**STEP 13**

BD03A165-01

Identify, tag, and disconnect parking brake hose from parking brake. Plug hose and cap fitting to prevent entry of foreign matter into hydraulic system. Move hose away from transmission. Remove four bolts and two straps securing center drive shaft to transmission output flange. Disconnect center drive shaft from transmission.

## FRONT AXLE

### Removal

#### STEP 1

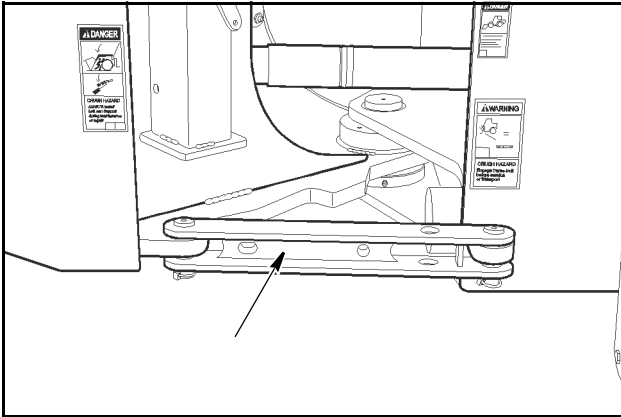

BD03A040-01

Park machine on level surface. Have assistant put articulation lock in LOCKED position.

**IMPORTANT:** If machine is equipped with quick-attached components, disconnect them from machine prior to proceeding.

#### STEP 2

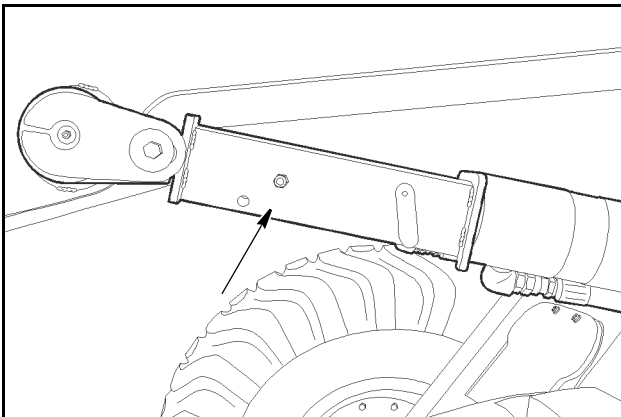

BD03A092-01

Raise bucket and have assistant install safety link. Lower loader arms slowly until safety link is supporting loader arms.

#### STEP 3

Stop engine. Actuate brake pedal several times to discharge brake accumulators. Put key switch in ON position and move loader control lever back and forth at least 30 times to release any pressure from hydraulic circuit. Put key switch in OFF position.

#### STEP 4

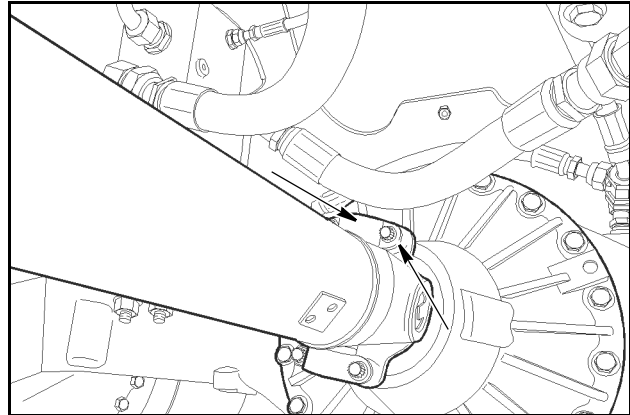

BD03A167-01

Remove four bolts and two straps securing front drive shaft to front axle.

#### STEP 5

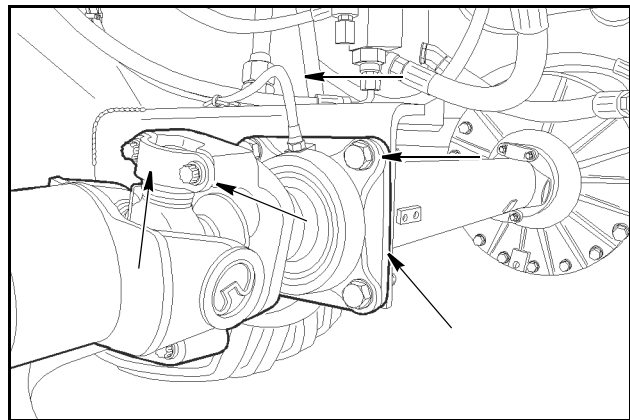

BD03A166-01

Remove clamp securing lubrication hose to machine and nut securing opposite end of hose. Remove four bolts and two straps securing center drive shaft to front drive shaft. Use a pry bar to separate drive shafts. While supporting center bearing and front drive shaft, remove four nuts and bolts and eight washers. Lower center bearing and front drive shaft from mounting plate and remove from machine.

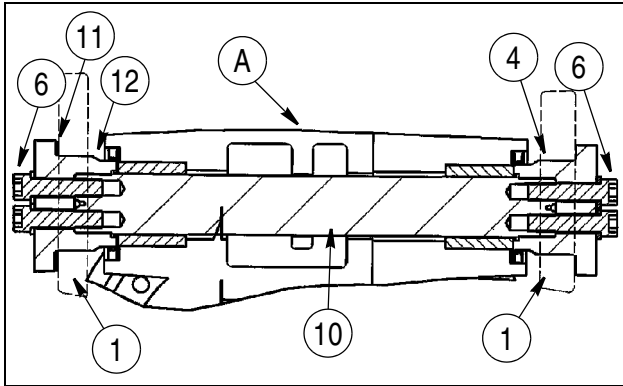
**STEP 16**

BS01E091

Lubricate pivot pin (10) using Molydisulfide Grease. At rear of trunnion (1), install pivot pin into trunnion and axle (A). Install shim pack (11), rear cap (12) with O-ring installed, and two washers and bolts (6). At front of trunnion install front cap (4) with O-ring installed. Use Loctite primer 747 on bolt threads and let dry for 70 seconds. Then, apply Loctite 243 on bolt threads and install washers and bolts (6). Tighten bolts (6) to a torque of 325 to 353 Nm (240 to 260 pound feet).

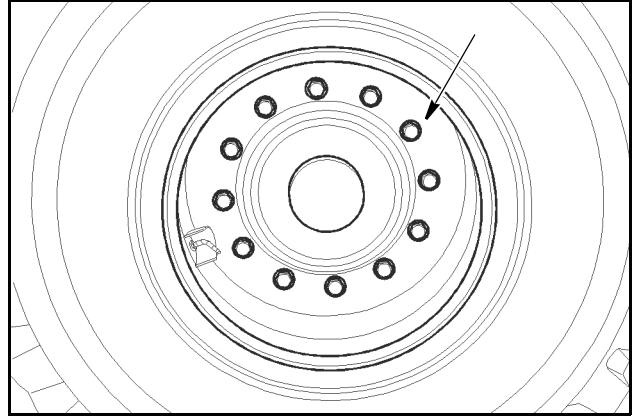
**STEP 17**

BD01F295-01

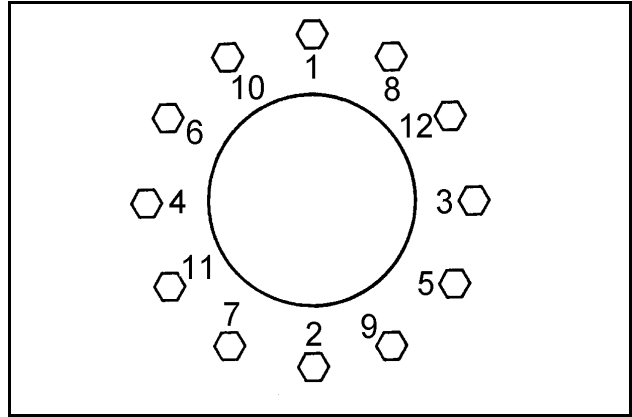

B0987A88

Install both wheels on front axle and secure. Tighten bolts to a preliminary torque of 298 Nm (220 pound feet) in sequence indicated; then tighten to a torque of 640 to 720 Nm (475 to 530 pound feet) in same sequence.

**STEP 18**

Remove hydraulic jack supporting rear axle and jack stands supporting loader.

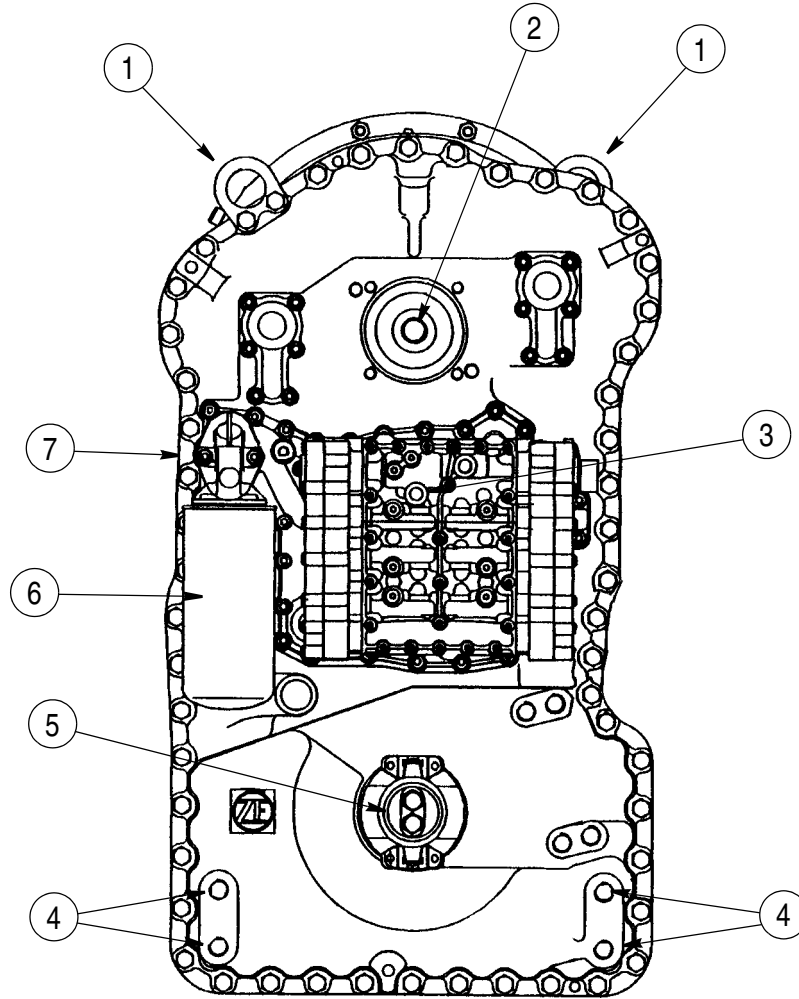

BS01B048

- |                                  |                       |
|----------------------------------|-----------------------|
| 1. LIFTING LUGS                  | 5. OUTPUT FLANGE REAR |
| 2. POWER TAKE OFF                | 6. FILTER             |
| 3. TRANSMISSION CONTROL VALVE    | 7. FILTER HEAD        |
| 4. TRANSMISSION SUSPENSION BORES |                       |

**COMPONENT LOCATIONS REAR VIEW**

CLICK HERE TO **DOWNLOAD** THE COMPLETE MANUAL

- Thank you very much for reading the preview of the manual.
- You can download the complete manual from: [www.heydownloads.com](http://www.heydownloads.com) by clicking the link below



- Please note: If there is no response to CLICKING the link, please download this PDF first and then click on it.

CLICK HERE TO **DOWNLOAD** THE COMPLETE MANUAL

## TRANSMISSION OVERHEATING

1. Operate machine in normal operating conditions and observe:
  - A. Verify actual oil temperature at test point. Normal operating temperature can be 56°C (100°F) above the ambient temperatures.
  - B. Use a stop watch to establish the exact length of time required to reach the overheating condition.
  - C. Observe engine temperature, does the engine overheat? Which overheats first - engine or transmission?
2. When the transmission reaches overheated condition, shift to Neutral and maintain engine RPM at a fast idle (1250 to 1450 RPM).
  - A. Oil temperature returns to Normal - establish length of time.
    1. Check oil level, type and grade is correct (See Section 1002).
    2. Check operator's gear selection is correct for conditions.
    3. Make sure brakes are fully released.
    4. Check the engine full throttle and stall speeds are correct as specified (See Section 2002).
  - B. Oil temperature remains overheated.
    1. Check for dirty radiator - airflow restricted.
    2. Check for engine overheating problem.
    3. Check for faulty oil temperature gauge and sender or switch (See Section 4002).
3. Perform all the pressure and flow tests.
4. Compare the pressure and flow test results to the specifications in this section to determine if any circuits are not within specifications.
5. Refer to Pressure Test Results to determine possible cause of any test results not within specifications.

### STEP 19

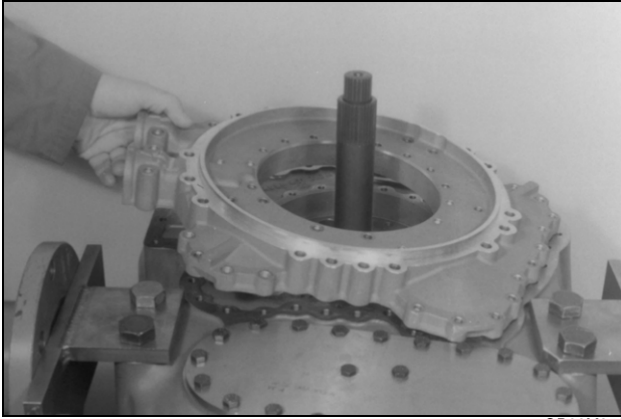

GD98M856

Remove the hex head screws and remove the oil feed housing. Remove the flat gasket.

### STEP 20

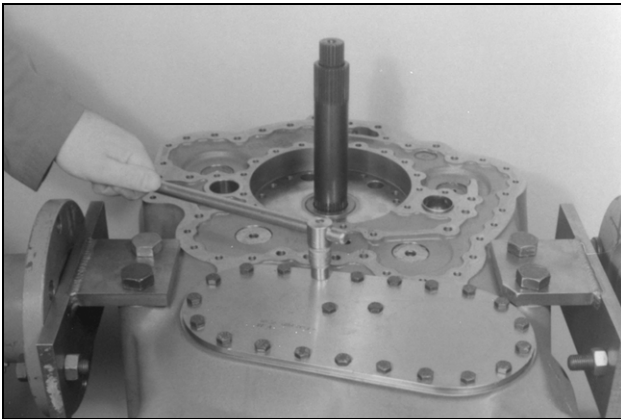

GD98M860

Remove the hex head screws, cover, and flat gasket.

### STEP 21

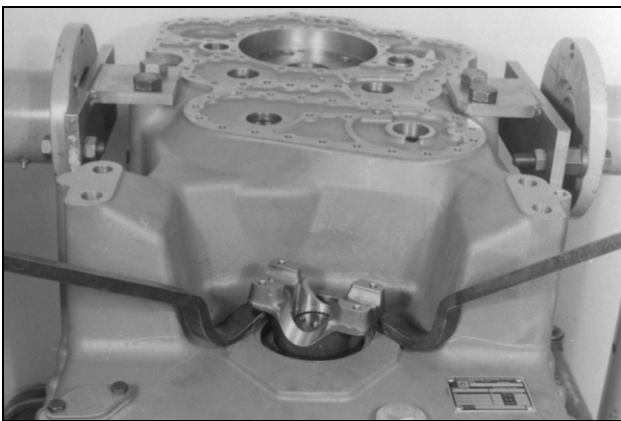

GD98M861

Remove the lock plate, hex head screws, and pry the converter side output flange from the shaft.

### STEP 22

Pry the shaft seal out of the housing bore.

### STEP 23

Turn the transmission 180 degrees and remove the rear output flange.

### STEP 24

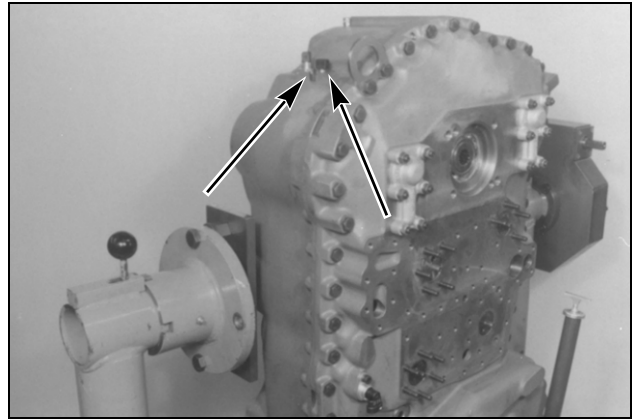

GD98M862

Remove the speed sensor and both inductive transmitters.

### STEP 25

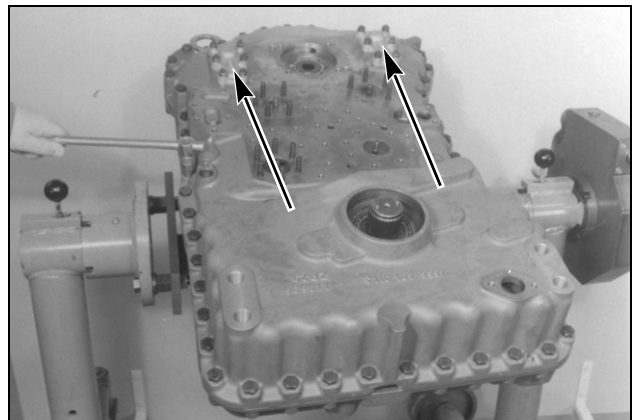

GD98M863

Remove the hex nuts and the two covers.

### STEP 26

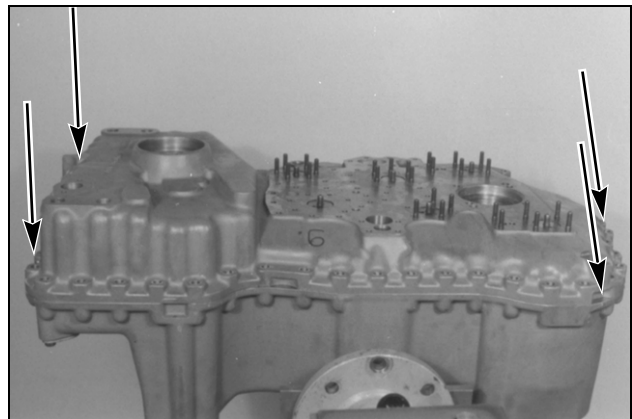

GD98M864

Install CAS2802 alignment dowel set.

**NOTE:** The following steps describe the common removal of all clutches.

**STEP 77**

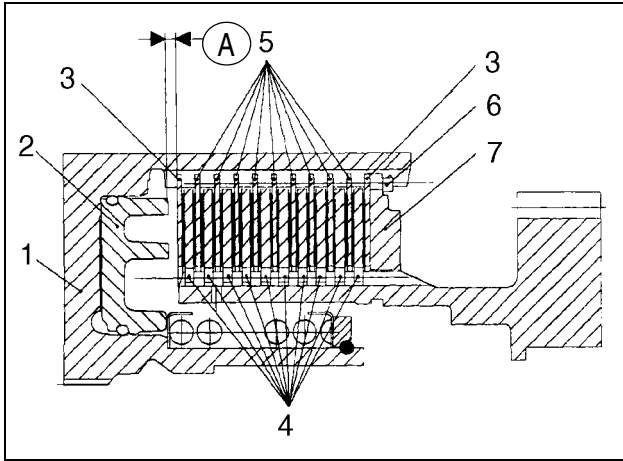

225B

- 1. PLATE CARRIER
- 2. PISTON
- 3. OUTER PLATE - ONE-SIDED COATED
- 4. INNER PLATES
- 5. OUTER PLATES - COATED ON BOTH SIDES
- 6. SNAP RING
- 7. END SHIM
- A RUNNING CLEARANCE 2.5 TO 2.7 MM (0.098 TO 0.106 IN)

Install clutch disc plates in KV and KR clutch disc carriers in position and sequence shown above. Install outer plates (3) with steel faced side facing piston and end shim (7). Install two inner plates (4) on the end shim side.

**NOTE:** Snap rings of different thickness are available for adjustment of the running clearance. To ensure correct adjustment, do not apply oil to clutch discs until after adjustment is completed.

**STEP 78**

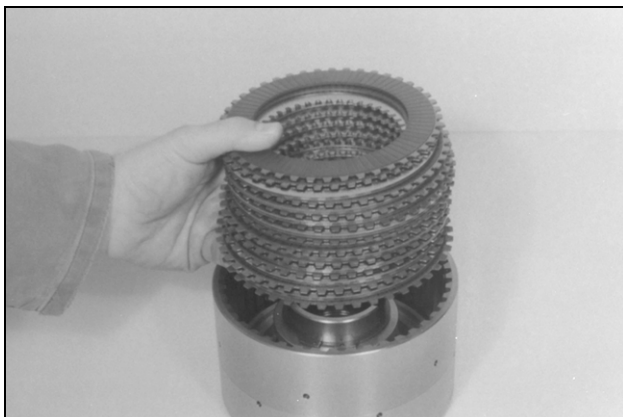

GD98M616

Install the clutch disc pack.

**STEP 79**

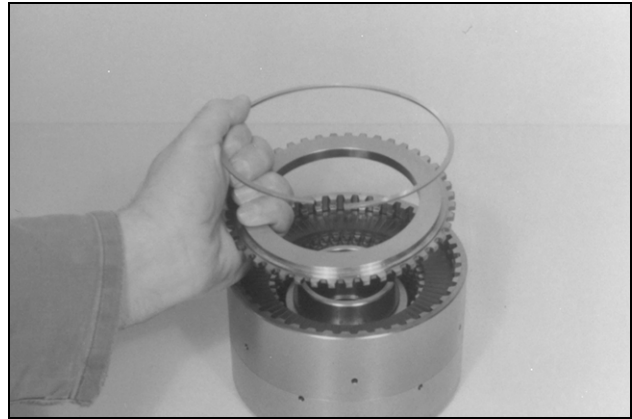

GD98M617

Install end shim and snap ring.

**STEP 80**

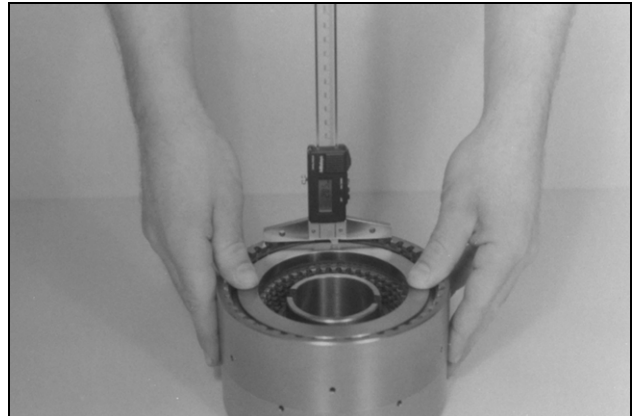

GD98M618

Adjust running clearance to 2.5 to 2.7 mm (0.098 to 0.106 in). Press down on the end shim with approximately 10 kg (20 lb). Measure and record dimension (A) from carrier face to end shim using depth gauge as shown.

Example

Dimension A . . . . . 7.25 mm (0.29 in)

**STEP 128**

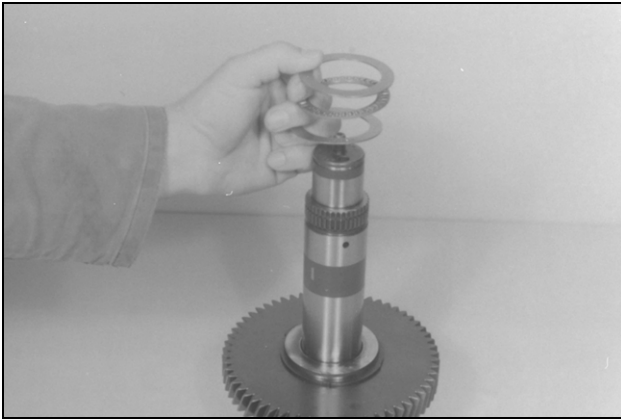

GD98M658

Assemble two thrust washers and thrust bearing.

**NOTE:** Upper and lower thrust washers are the same thickness.

**STEP 129**

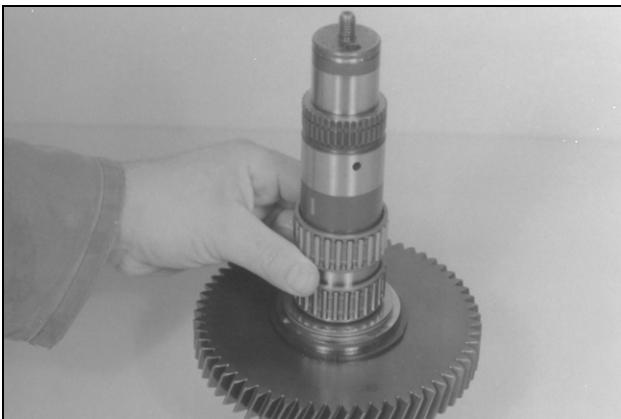

GD98M659

Install both needle bearings.

**STEP 130**

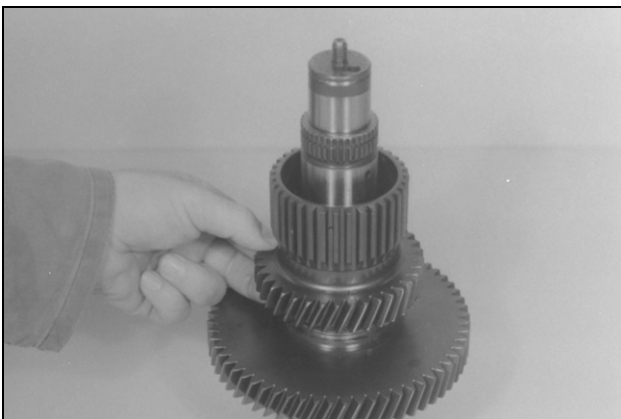

GD98M660

Install the idler gear.

**STEP 131**

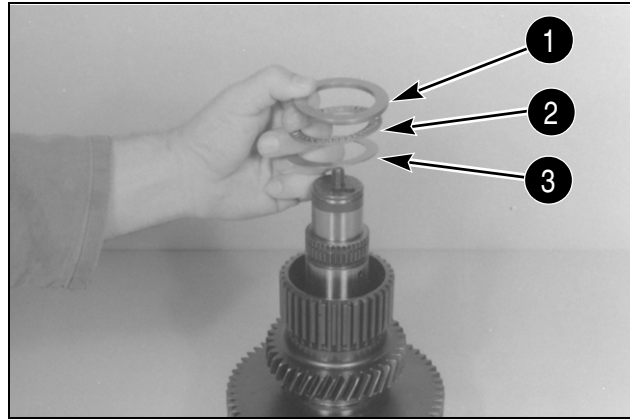

GD98M661

Assemble thrust washer (3), thrust bearing (2), and thrust washer (1). Install the thrust washer (1) with the chamfer facing the thrust bearing.

**STEP 132**

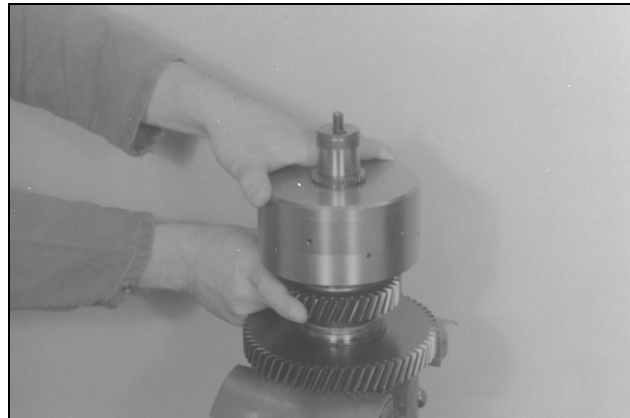

GD98M662

Install the assembled clutch disc carrier until all the inner discs are engaged.

**STEP 133**

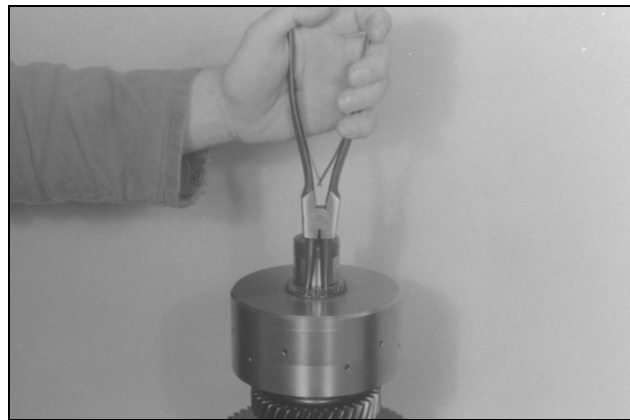

GD98M663

Install snap ring to secure clutch disc carrier.

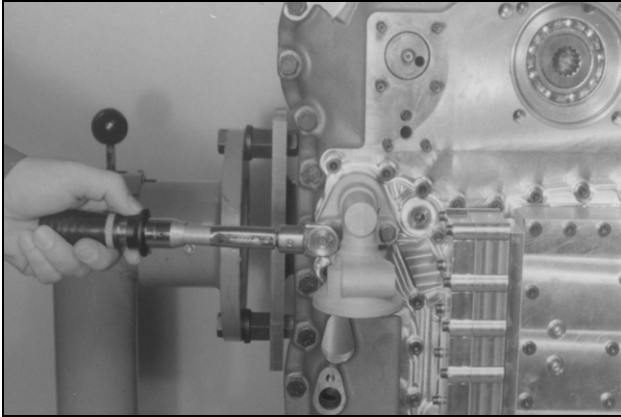
**STEP 186**

GD98M729

Install new O-rings in recesses of oil filter head. Position filter head on transmission and secure using two socket head screws. Tighten screws to a torque of 25 Nm (221 pound inches).

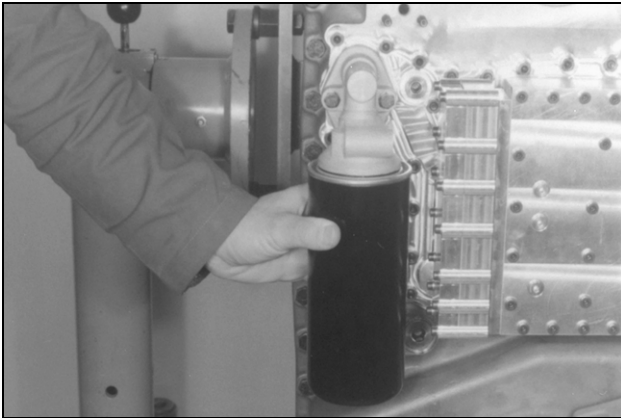
**STEP 187**

GD98M730

Install a new transmission filter.

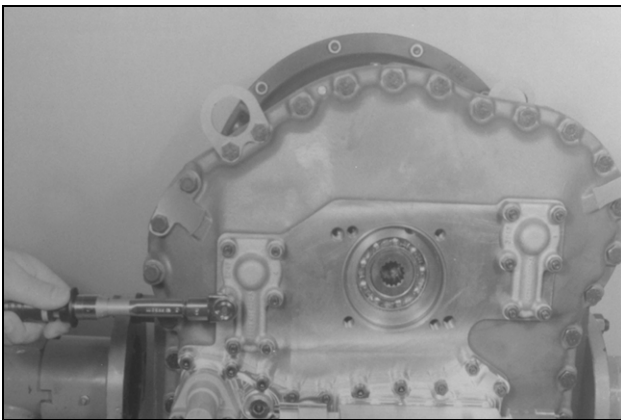
**STEP 188**

GD98M733

Install new O-rings in oil distribution covers. Install the two oil distribution covers on the housing with hex nuts and flat washers. Tighten to a torque of 25 Nm (221 pound inches).

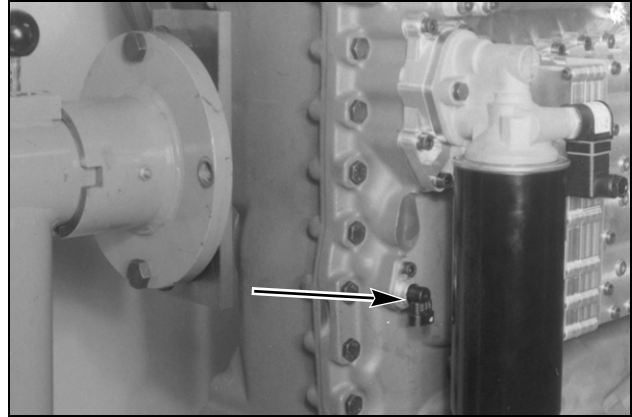
**STEP 189**

GD98M735

Apply grease to the new O-ring and install the speed sensor with the socket head screw. Tighten the screw to a torque of 23 Nm (204 pound inches).

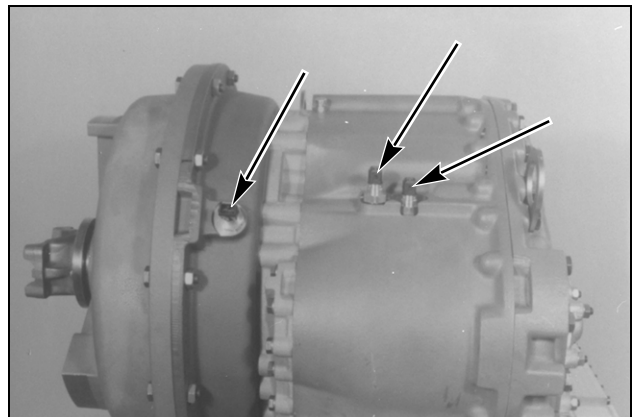
**STEP 190**

GD98M736

With new O-rings, install the inductive transmitters. Tighten to a torque of 30 Nm (265 pound inches).

**STEP 191**

Install the breather.

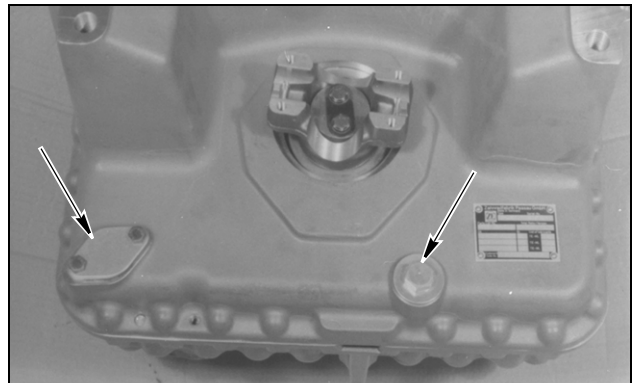
**STEP 192**

GD98M737

Install the gasket and the cover plate. Tighten to a torque of 23 Nm (204 pound inches). With a new O-ring, install the screw plug. Tighten to a torque of 140 Nm (103 pound feet).

**STEP 18**

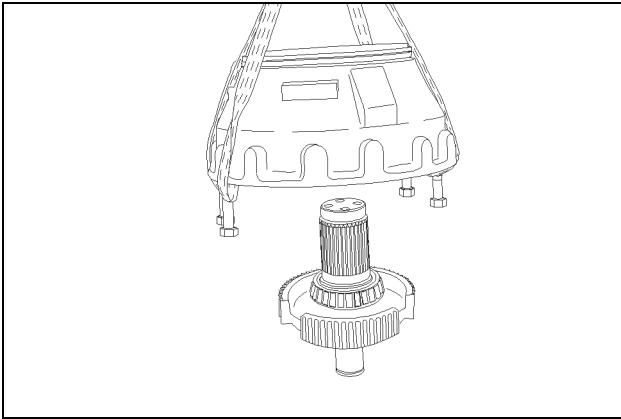

BD07N087-01

Attach an acceptable lifting device to the brake housing and remove from the carrier.

**STEP 19**

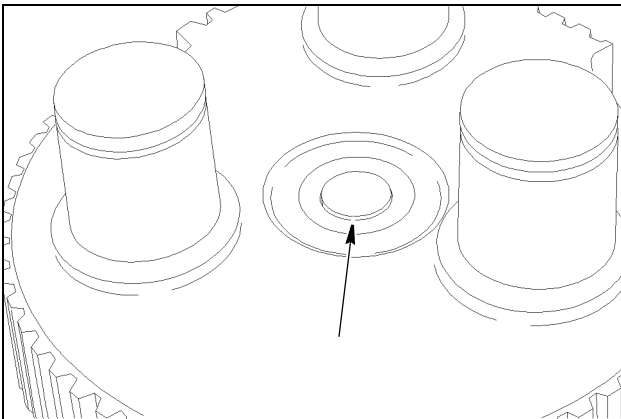

BD07N046-01

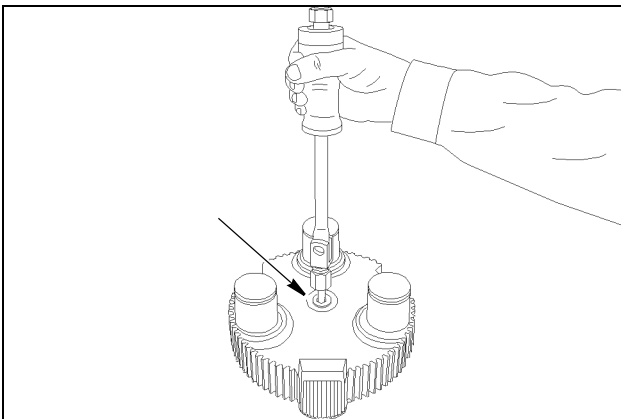

BD06G015-01

Inspect the stop pin (plug) for wear. If necessary drill a hole into the pin, use acceptable tool and remove the pin.

**STEP 20**

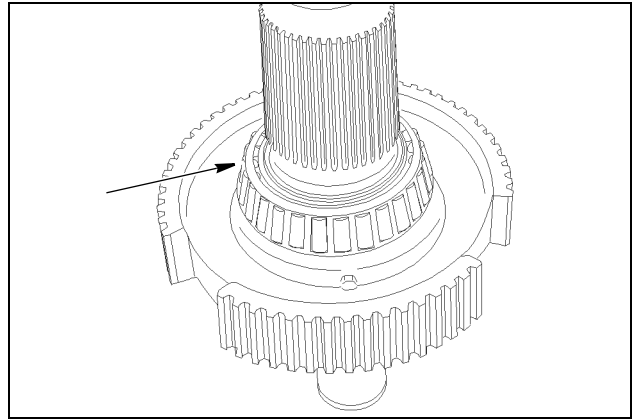

BD07N047-01

Inspect the carrier output shaft bearing. If damaged score with a die grinder and remove bearing cage. Then score bearing with die grinder and break with a hammer and chisel.

**STEP 21**

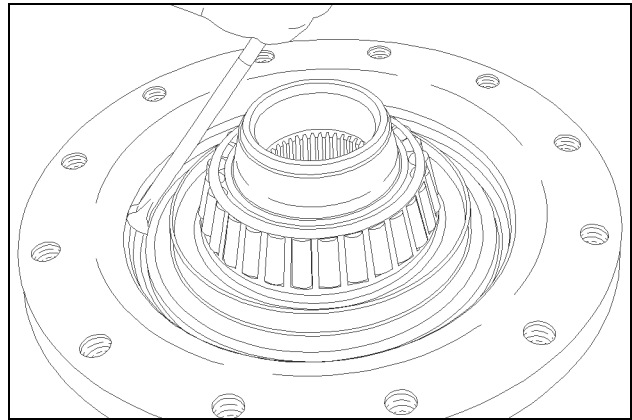

BD07N035-01

Remove the face seal ring metal ring from the wheel end shaft using a pry bar.

**STEP 68**

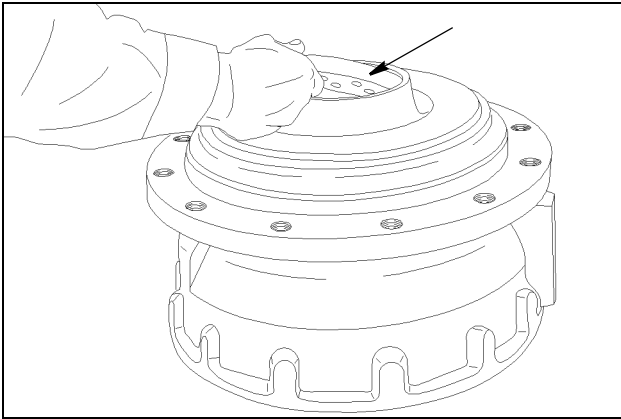

BD07N090-01

Install the retainer into the wheel end on the output shaft of the carrier.

**STEP 69**

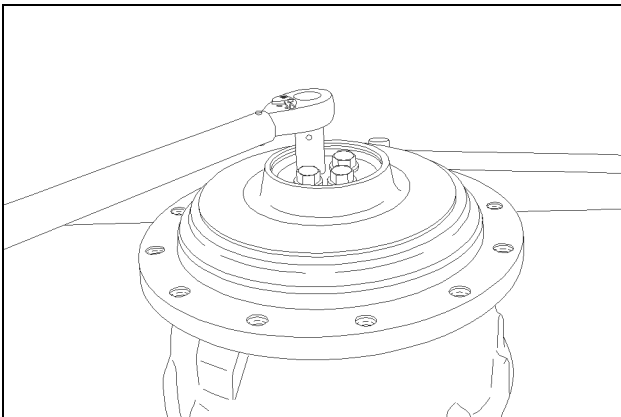

BD07N092-01

Install the four new bolts holding the wheel end to the output shaft of the carrier. Tighten the bolts to a torque of 500 Nm (368.8 pound feet). Rotate brake housing several times in both directions and recheck torque.

**IMPORTANT:** *Do not reuse locking bolts, just one time installation is permitted.*

**STEP 70**

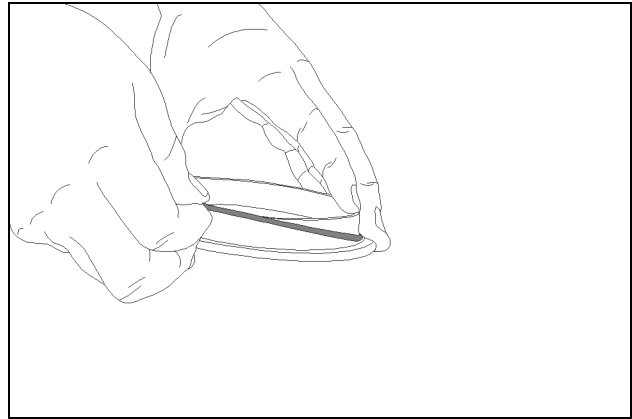

BD07N095-01

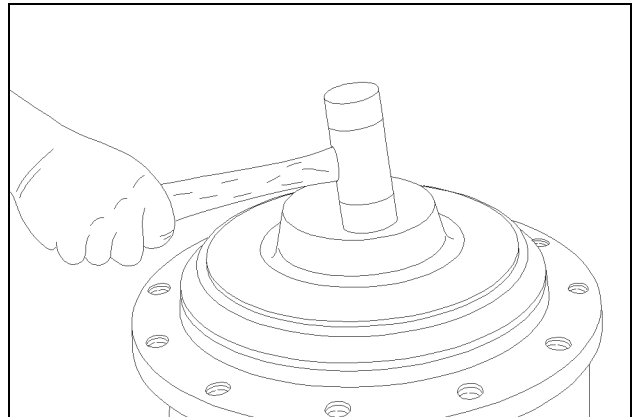

BD07N096-01

Install a new O-ring on the cover and use a mallet and install the cover into the wheel end.

**STEP 108**

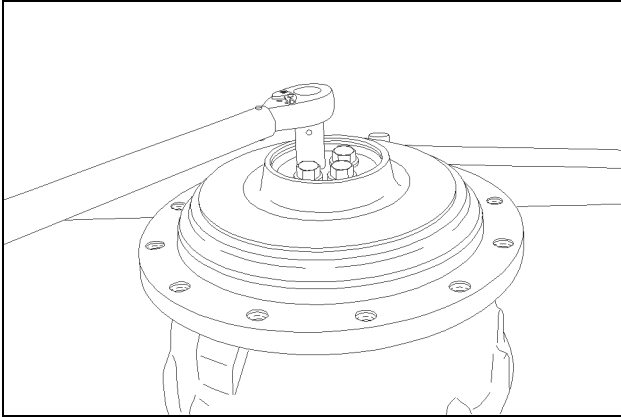

BD07N092-01

Install the four bolts and tighten to a torque of 500 Nm (369 pound feet). Rotate brake housing several times in both directions and recheck torque.

**STEP 109**

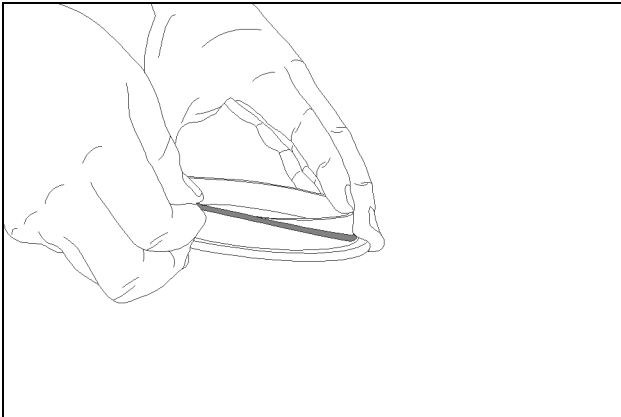

BD07N095-01

Install a new O-ring on the wheel end cover.

**STEP 110**

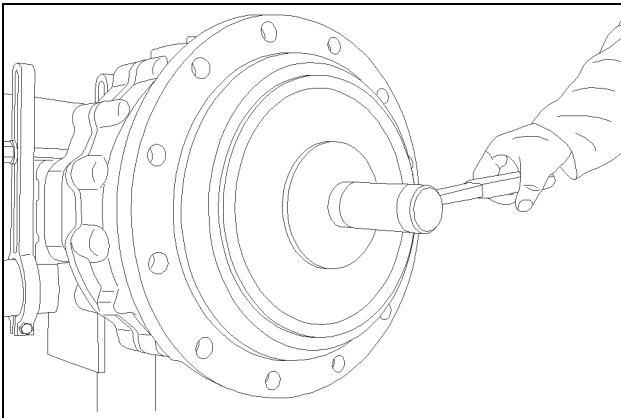

BD02D053-01

Install the wheel end cover into the wheel end.

**STEP 111**

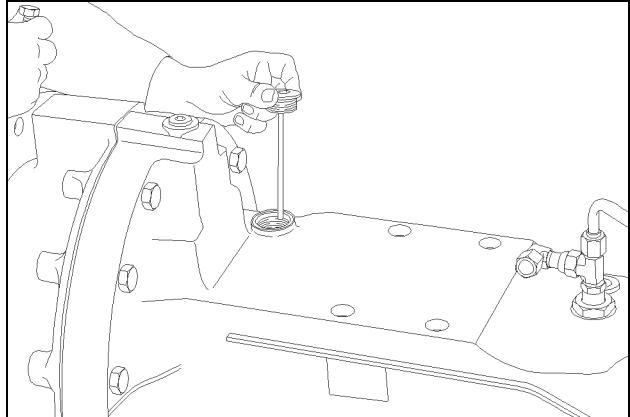

BD07N212-01

Remove the dip stick from the axle housing. Refill the axle with 22 Liters (23.2 quarts) of the proper Transaxle fluid (SAE 80W-140).

**STEP 112**

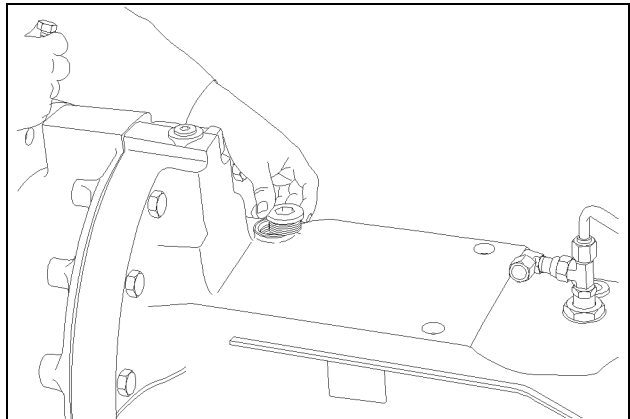

BD07N213-01

Insert dip stick back into the axle but do not screw in set it off on the edge fill hole, oil level should be between upper and lower level on the dip stick. Install plug into axle housing and torque plug to 50 Nm (36.9 pound feet).

**STEP 148**

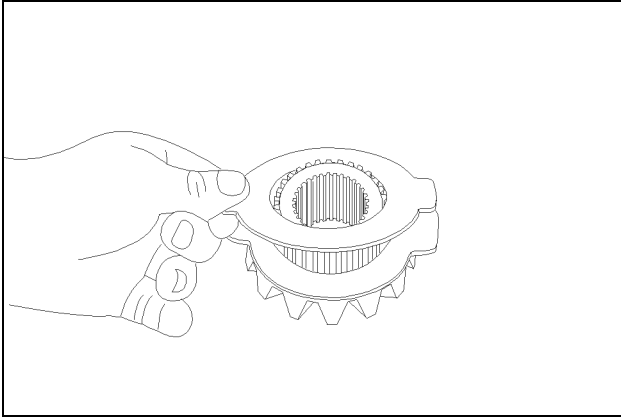

BD07N150-01

Install **one** reaction plate on the outer bevel gear.

**STEP 151**

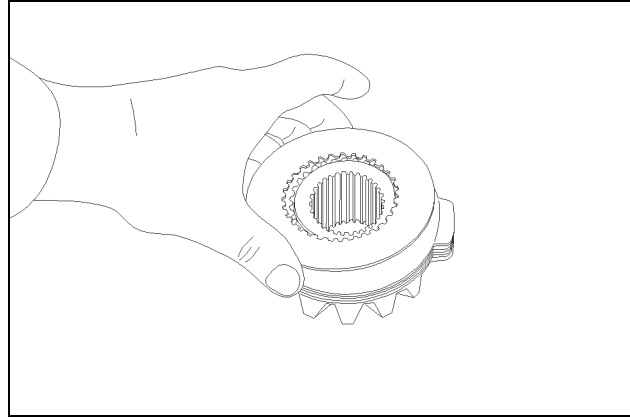

BD07N155-01

Install **two** friction plates on the outer bevel gear.

**STEP 149**

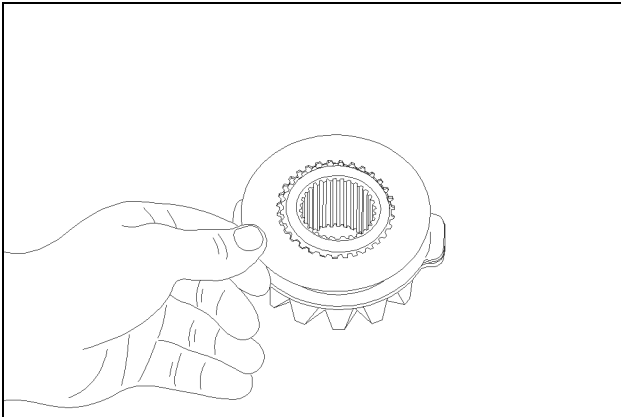

BD07N151-01

Install **one** friction plate on the outer bevel gear.

**STEP 152**

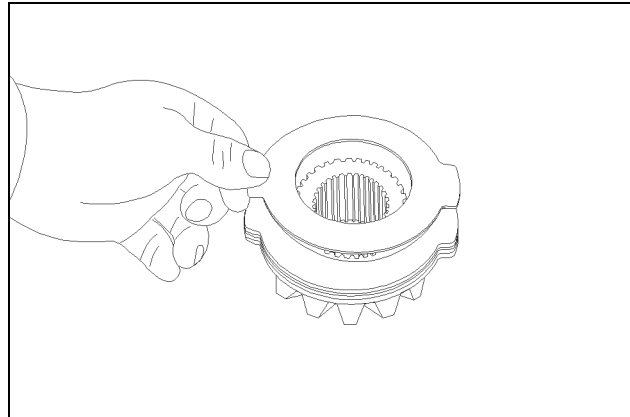

BD07N156-01

Install **one** reaction plate on the outer bevel gear.

**STEP 150**

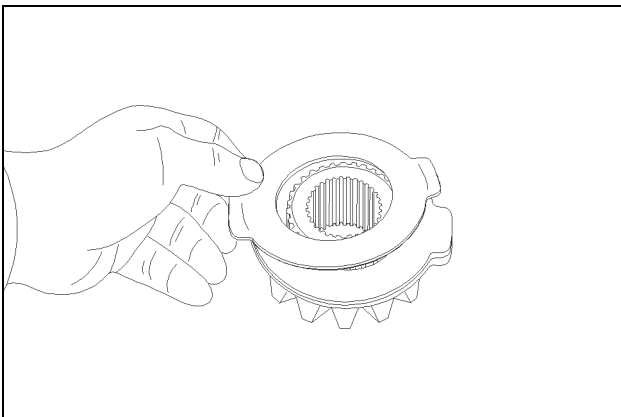

BD07N153-01

Install **two** reaction plates on the outer bevel gear.

**STEP 189**

**WARNING:** Always wear heat protective gloves to prevent burning your hand when handling heated parts.

SM121A

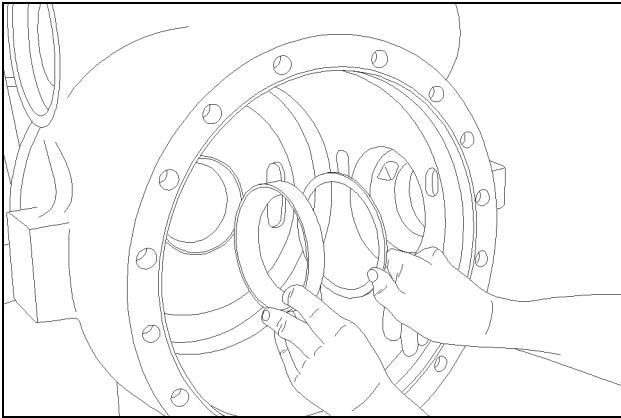

BD06G141-01

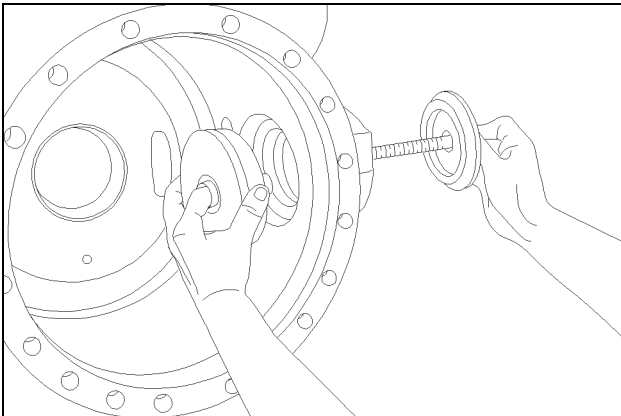

BD06G142-01

Heat the inner bearing hole on the differential housing to approximately 120° C (248° F). Install the shim set determined in Step 187 in the bearing bore and press the bearing cup into to the bearing hole using a suitable tool.

**STEP 190**

**WARNING:** Always wear heat protective gloves to prevent burning your hand when handling heated parts.

SM121A

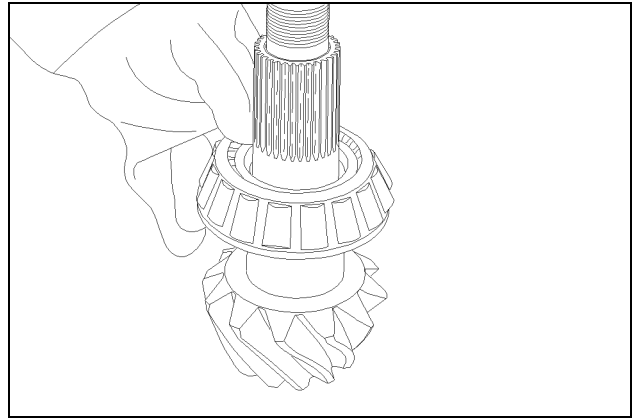

BD07N178-01

Heat the pinion inner bearing to 120° C (248° F) in a bearing oven. Wearing heat resistance gloves or mittens, install the bearing on the pinion shaft until contact.

*After installing bearing on pinion shaft, allow the bearing to cool to ambient temperature.*

## Drive Pinion Bearing Rolling Torque Adjustment

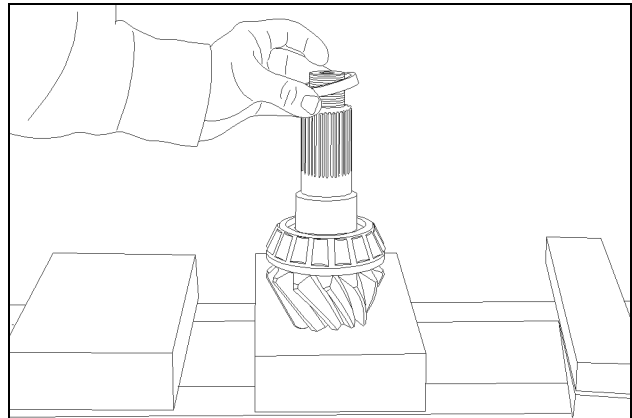
**STEP 191**

BD07N175-01

Install a 9.03 mm (0.35 inch) thick spacer on the pinion shaft.

# GEAR TOOTH CONTACT PATTERNS

## Ideal Tooth Contact Pattern

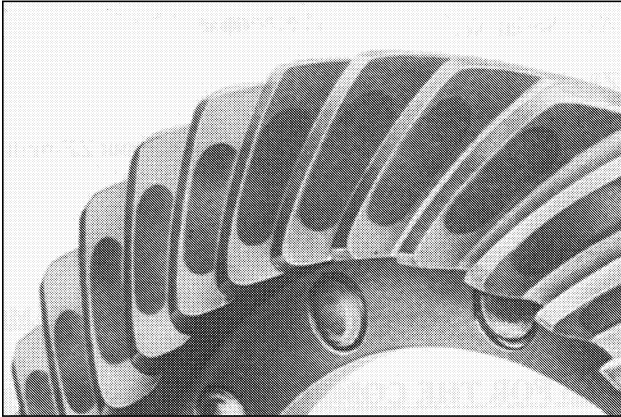

BS01D011

COAST SIDE (CONCAVE)

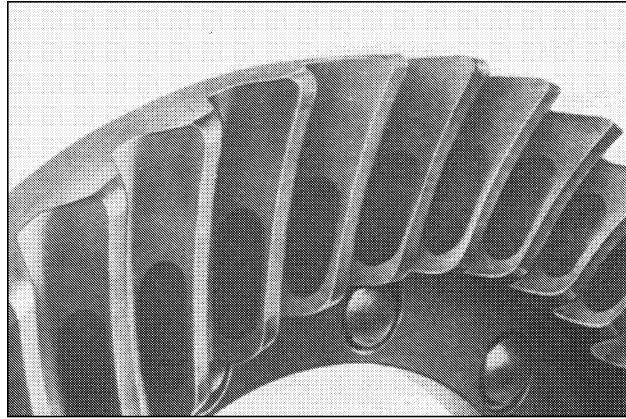

BS01D012

DRIVE SIDE (CONVEX)

## Pinion Distance Must Be Increased

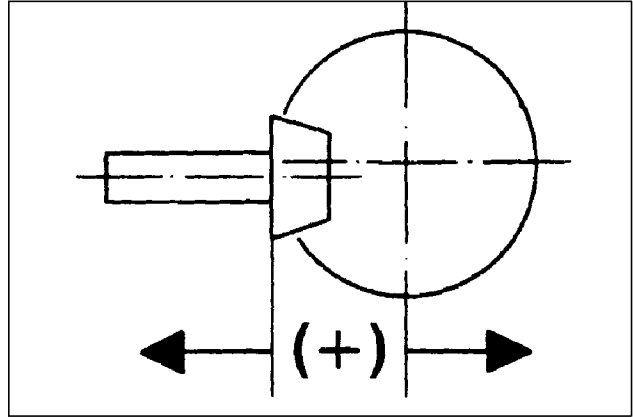

BS01D009

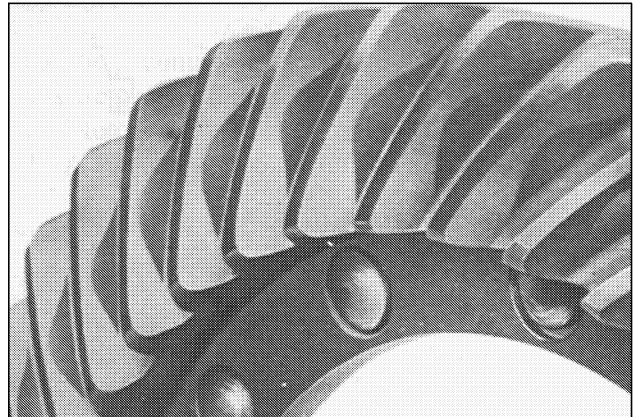

BS01D013

COAST SIDE (CONCAVE)

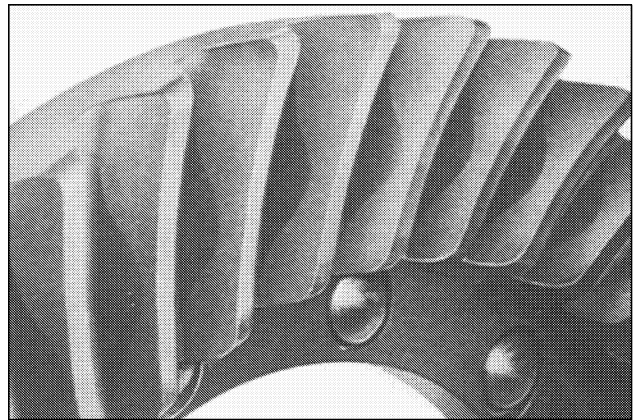

BS01D014

DRIVE SIDE (CONVEX)

## Cleaning and Inspection

**IMPORTANT:** Do not use compressed air to dry bearings. Allow bearings to air dry.

### STEP 36

Clean all parts except friction plates in brake disc pack using cleaning solvent. WEAR FACE PROTECTION WHEN USING COMPRESSED AIR. Use compressed air to clear passages in planetary ring gear and brake housing.

### STEP 37

Inspect bearing rollers for pitting, scoring, deformation, or other damage. Check inner face and bearing cage for deformation, dents, and other damage. Check associated bearing cups for scratches, grooves, or cracks. Check bearings for rough spots or binding by holding bearing and rotating. If bearing binds or action is not smooth, replace the bearing.

### STEP 38

Inspect bearing cups for pitting, scoring, cracks, or other damage. Replace if any of these conditions are seen.

**NOTE:** If a bearing or bearing cup requires replacement, the associated part must also be replaced.

### STEP 39

Check planetary ring gear, planetary gears, and planetary carrier gear teeth for cracks, breaks, chipping, or other damage. Replace the part if any of these conditions are seen. Check planetary carrier shaft splines for broken, cracked, or twisted condition. Replace if necessary.

### STEP 40

Check wheel end shaft for cracked, broken, or twisted splines. Replace if any of these conditions are seen.

## Assembly

**NOTE:** Tools and axle shown in the following photographs may appear slightly different than the tools and axle you may have. The use of the tools and disassembly/assembly of axle is the same regardless of appearance.

### STEP 41



**WARNING:** Always wear heat protective gloves to prevent burning your hand when handling heated parts.

SM121A

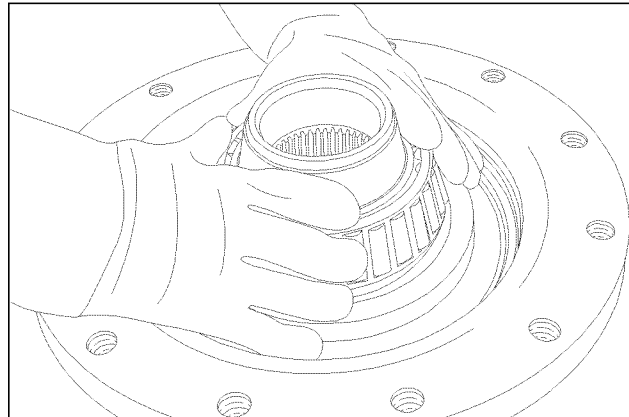

BD07N040-01

Heat the wheel end shaft outer bearing to 120° C (248° F) in a bearing oven. Wearing heat resistant gloves or mittens, install the bearing on the wheel end shaft until the bearing is against the shoulder on the wheel end shaft.

### STEP 42

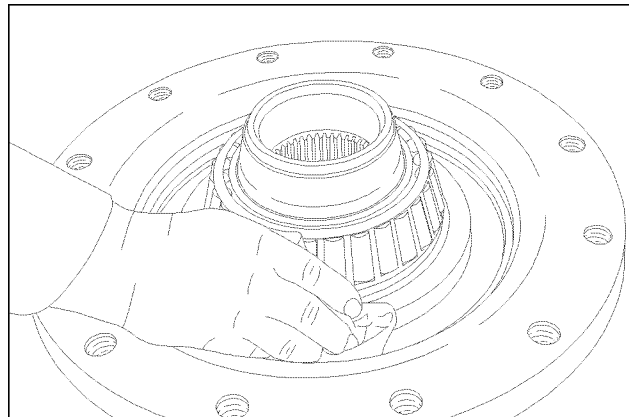

BD07N037-01

Clean the seal ring mounting surface with solvent.

**STEP 82**

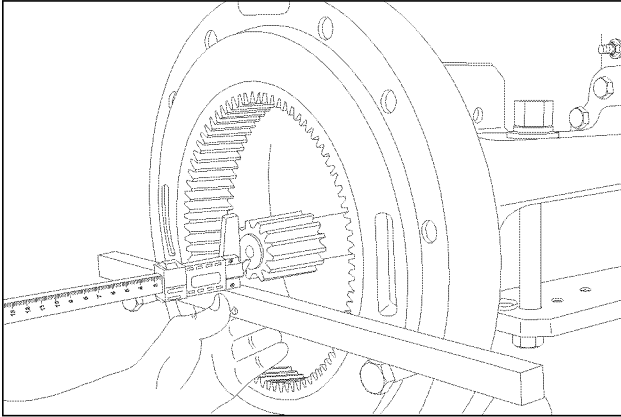

BD08B034-01

Determine dimension B from the mounting face of the axle housing to the face of the sun gear.

Example:

Dimension B ..... 19 mm (0.75 inch)

**STEP 83**

Subtract dimension A from dimension B. Then subtract 1.25 mm (0.05 inch) from the difference. The difference is the required shim size.

Example:

Dimension A	21.25 mm (0.84 inch)
Dimension B	-19.00 mm (0.75 inch)
Difference	<hr/> 2.25 mm (0.09 inch)
Required end play	<hr/> -1.25 mm (0.05 inch)
<b>Difference = shim size</b>	<b>1.00 mm (0.04 inch)</b>

**STEP 84**

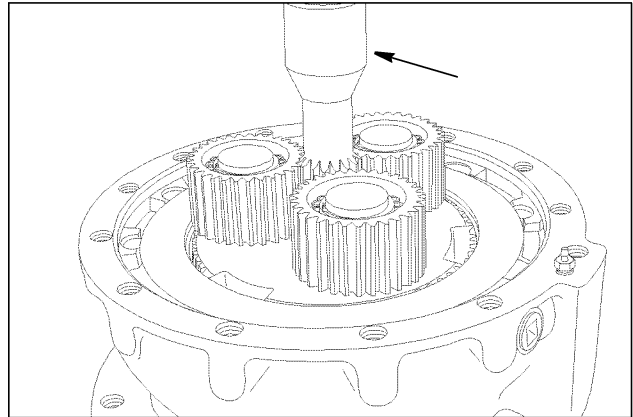

BD07N113-01

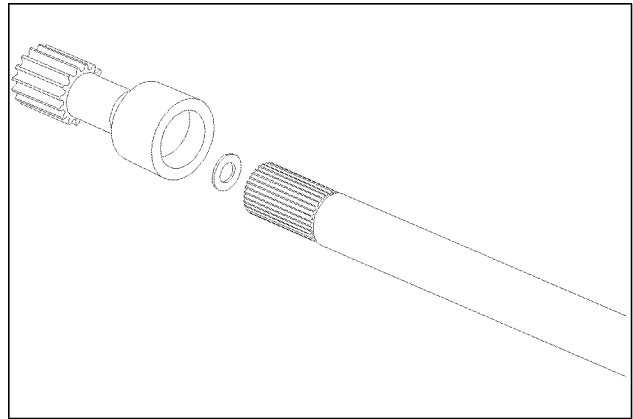

BD08B035-01

Install the sun gear shaft into the planetary gears. Install the shim set (size as determined in Step 83) into the sun gear shaft with grease.

**STEP 85**

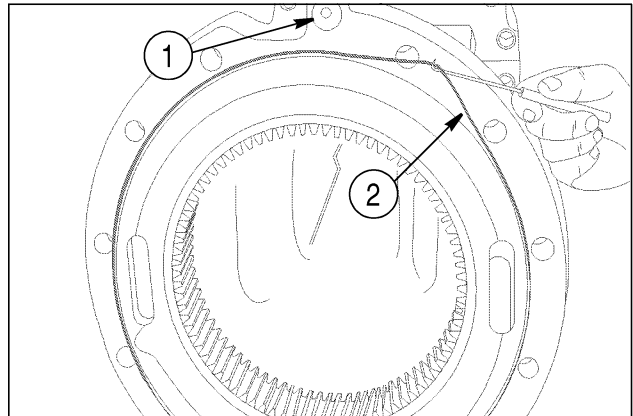

BD07N013-01

Install a new O-ring in brake port (1), and a new O-ring on the axle housing (2).

### STEP 127

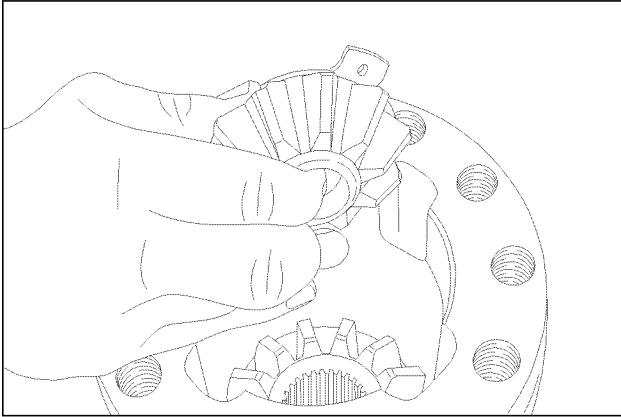

BD07N131-01

Remove the remaining two spider gears and thrust washers from the differential housing.

### STEP 128

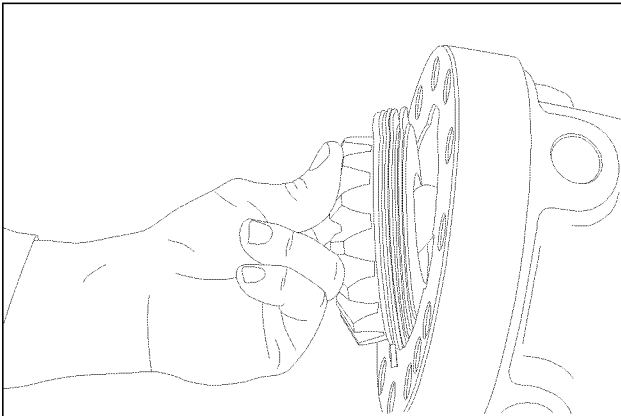

BD07N129-01

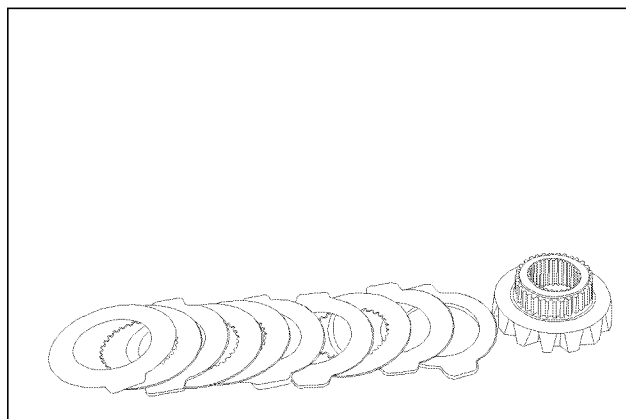

BD07N114-01

Remove the inner set of clutch plates, thrust washer, and bevel gear from the differential housing.

### STEP 129

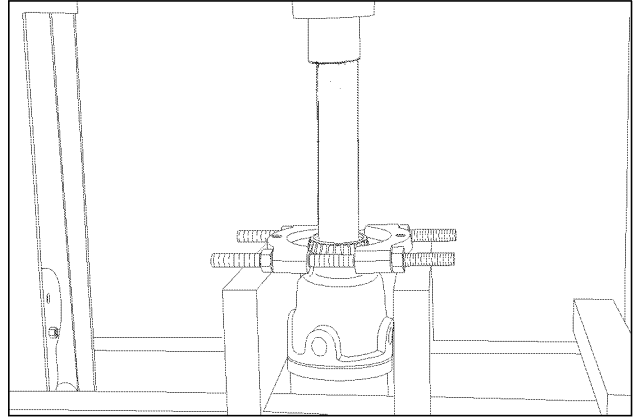

BD07N104-01

If required, remove bearing from differential housing using a suitable puller and a press.

### STEP 130

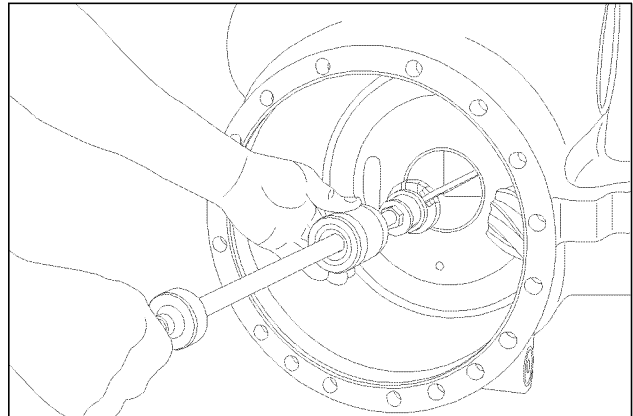

BD06G131-01

Pull the bearing cups and shims from both axle housings.

**NOTE:** Make sure to identify the shims into which axle housing they were removed.

**STEP 173**

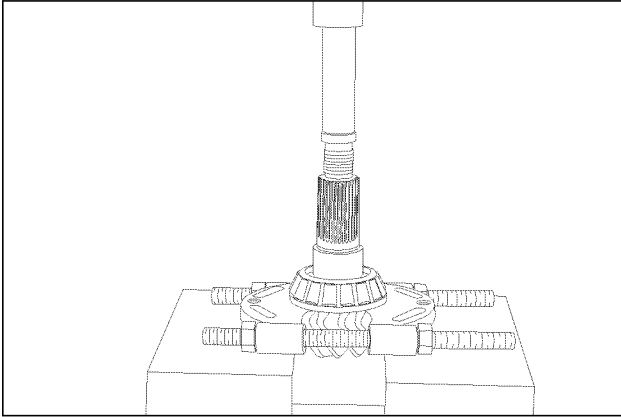

BD07N176-01

Remove inner bearing from the drive pinion using a suitable puller and a press.

**Brake Tube Removal**

**STEP 174**

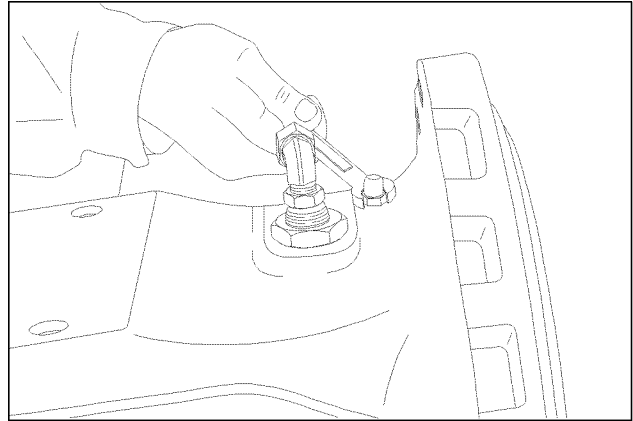

BD07N030-01

Remove the plug with the breather installed from the axle housing.

**STEP 175**

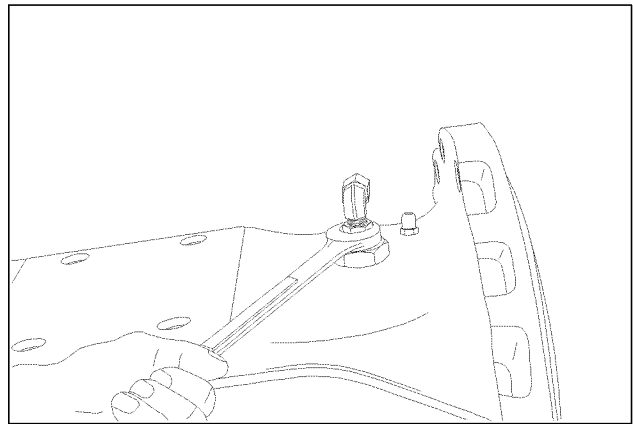

BD07N001-01

Remove fitting from the brake tube on the axle housing.

### STEP 211

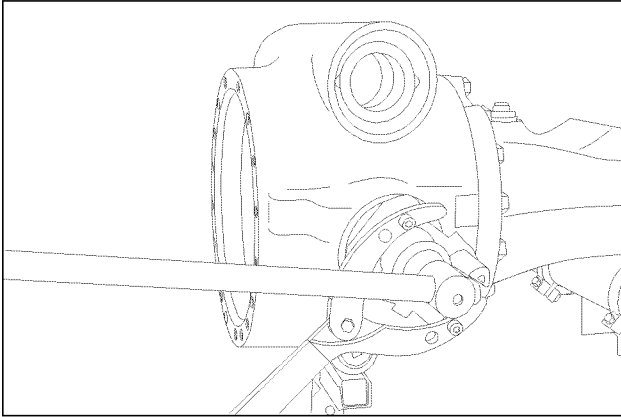

Install a holding wrench on input flange. Hold flange and tighten nut to a torque of 700 Nm (516 pound feet). Remove holding wrench.

**NOTE:** *When tightening rotate the pinion shaft in both directions several times.*

### STEP 212

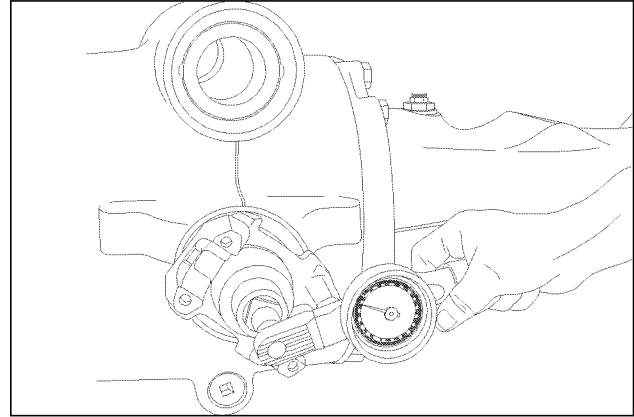

Check the rolling torque of the drive pinion bearing. The rolling torque should be 1.1 to 2.3 Nm (9.75 to 20 lb-inch). If rolling torque is too low, install a thinner spacer (Step 206); if rolling torque is too high, install a thicker spacer (Step 206).

### STEP 213

Remove the nut and input yoke from the drive pinion shaft.

## FRONT DRIVE SHAFT

### Installation

#### STEP 9

Apply antiseize compound to the bearing area of the front drive shaft.

#### STEP 10

Place the front drive shaft into position in the center bearing of the machine.

#### STEP 11

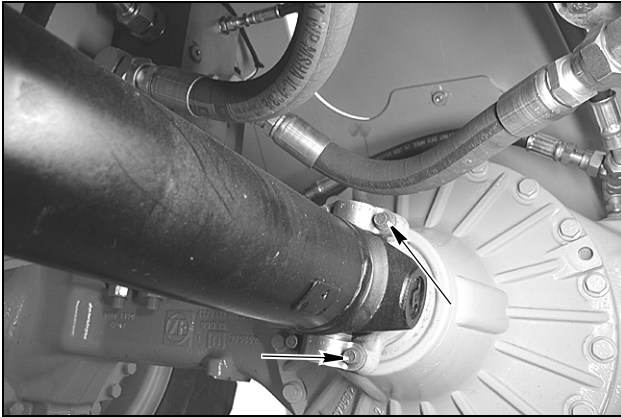

BD03A167

Install the bolts and straps that fasten the front drive shaft to the front axle. Tighten the bolts to a torque of 61 to 81 Nm (45 to 60 pound feet).

#### STEP 12

Apply antiseize compound to the splines on the front drive shaft.

#### STEP 13

Install the yoke to the front drive shaft, making sure the alignment marks made during removal are aligned.

**NOTE:** *If a new front drive shaft has been installed, make sure the yoke being installed is 90° to the yoke on the other end of the front drive shaft.*

#### STEP 14

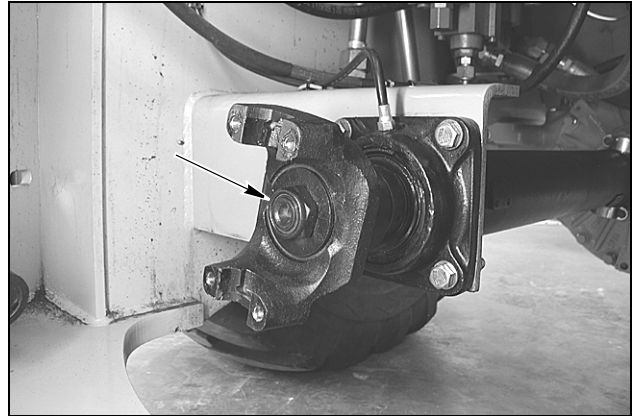

BD03A183

Install the lock nut and washer which fastens the yoke to the front drive shaft. Tighten the lock nut to a torque of 339 to 375 Nm (250 to 275 pound feet).

#### STEP 15

Tighten the set screws that secure the center bearing to the front drive shaft alternately until they stop turning and the hex head socket wrench starts to spring.

#### STEP 16

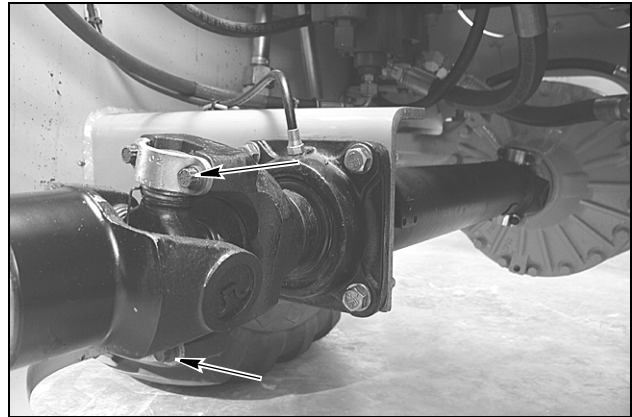

BD03A166

Install the bolts and straps that fasten the front drive shaft to the center drive shaft. Tighten the bolts to a torque of 61 to 81 Nm (45 to 60 pound feet).

## CHANGING TIRES

**WARNING:** The split rim wheels used on this machine can be dangerous. When inflating a tire on the machine, use a self-locking nozzle and stand at the front or rear of the tire.



When inflating a tire off the machine, put the wheel in a tire inflation cage. The retaining ring and rim can come off with enough force to result in death to a person in front of the rim.

48-44

1. Have a qualified tire mechanic service the split rim wheels used on this machine.
2. The correct tire equipment, especially a tire inflation cage, is required. Using the wrong procedure for a split rim wheel can result in death.

**IMPORTANT:** When installing a Michelin tire, lubricate the tire with a tire mounting lubricant and inflate the tire to 551 kPa, 5.5 bar (80 psi) to make sure that the tire is seated on the rim. Then decrease the pressure to the specified pressure.

## INSTALLING A WHEEL

1. Make sure the mounting surfaces of the rim and axle flange are clean and free of dirt and grease.
2. Install the wheel, hardened washers and wheel bolts.
3. Use a hand wrench (not an impact) to tighten the wheel bolts to pull the wheel against the planetary housing. DO NOT use an impact wrench to tighten the wheel bolts.
4. Tighten the wheel bolts to 298 Nm (220 pound-feet) in the sequence shown in Figure 1. Then tighten the wheel bolts in the same sequence to 640 to 720 Nm (475 to 530 pound-feet).

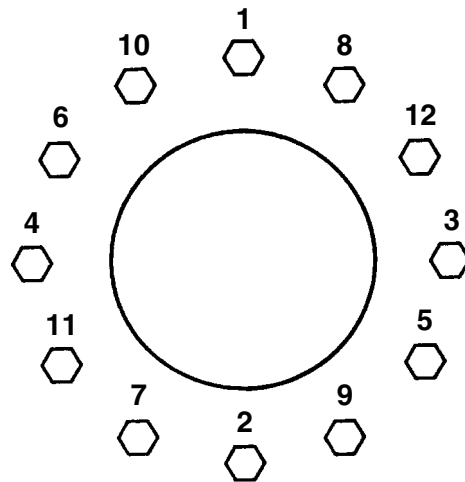

FIGURE 1. WHEEL BOLT TORQUE SEQUENCE

B0987A88



## TABLE OF CONTENTS

SPECIFICATIONS .....	3
SPECIAL TOOLS .....	3
TROUBLESHOOTING THE HYDRAULIC BRAKE SYSTEM .....	4
BLEEDING THE BRAKE SYSTEM .....	5
BRAKE MODULATION PRESSURE CHECK .....	7
Testing the Brake Modulation Pressure .....	7
Adjusting the Brake Modulation Pressure .....	8
SERVICE BRAKE SYSTEM PERFORMANCE (STORED ENERGY) .....	9
BRAKE PUMP OUTPUT TEST .....	10
Brake Valve Exploded View .....	11

7002-12

- |                                   |                                 |                                |
|-----------------------------------|---------------------------------|--------------------------------|
| 1. CAP SCREW (T 22 NM (16 LB-FT)) | 13. CAP (T 60 NM (44 LB-FT))    | 25. CHECK VALVE                |
| 2. O-RING                         | 14. SPOOL                       | 26. CARTRIDGE                  |
| 3. BUSHING                        | 15. PLUG (T 10 NM (88.5 LB-IN)) | 27. PLUG (T 60 NM (44 LB-FT))  |
| 4. SLEEVE                         | 16. PLUG (T 60 NM (44 LB-FT))   | 28. JET                        |
| 5. SPRING                         | 17. PLUG (T 22NM (16 LB-FT))    | 29. WVI UNIT                   |
| 6. SPRING RETAINER                | 18. VALVE SEAT                  | 30. PLUG (T 60 NM (44 LB-FT))  |
| 7. SPRING RETAINER                | 19. THROTTLE SCREW              | 31. PLUG (T 100 NM (74 LB-FT)) |
| 8. CIRCLIP                        | 20. PLUG (T 22NM (16 LB-FT))    | 32. RV UNIT                    |
| 9. SHAFT SEAL                     | 21. CAP                         | 33. SPRING RETAINER            |
| 10. SLEEVE LVE                    | 22. SLEEVE                      | 34. SLEEVE                     |
| 11. GUIDE RING                    | 23. SPRING RETAINER             | 35. THRUST RING                |
| 12. O-RING                        | 24. SLEEVE                      | 36. SLEEVE LVV                 |

## CHARGING THE ACCUMULATOR WITH DRY NITROGEN

**IMPORTANT:** The four valves A, D, and E must be in the positions noted in the procedure before connecting the Nitrogen Accumulator Charging Kit to the machine or nitrogen, refer to illustration on page 4.

1. Close the shutoff valve (D) by turning it all the way to the left (counterclockwise), refer to the illustration on page 4.
2. Close the gauge valve (E) by turning it all the way to the right (clockwise).
3. Connect the charging gauges to the nitrogen supply tank, open the supply tank valve.
4. Slowly turn valve (D) clockwise while watching the pressure gauge (B). Stop turning valve (D) when the needle on the gauge (B) reaches 10 bar (145 psi).

**NOTE:** If the needle goes over the needed pressure, quickly open and close valve (E) and check the pressure again.

The charging kit is now ready to be installed on the accumulator.

5. Remove the cap from the accumulator.
6. Loosen the sealing plug with an Allen wrench.

**NOTE:** Just loosen do not open to far so the gas leaks out

7. Install adapter 380001168 (F).
8. Back off the needle valve (A) on the accumulator end of the charging hose by turning it counterclockwise to the maximum amount. This prevents nitrogen from escaping from the accumulator when the charging hose is attached to the accumulator gas charging valve.
9. Install the charging hose fitting onto the adapter.
10. Tighten the needle valve by turning it clockwise. Slowly open the gauge valve (E) and observe the reading on the gauge. This reading is the nitrogen pressure level inside the accumulator.

11. Fill the accumulator to pressure according to Temperature/Charge Pressure chart.

TEMPERATURE		CHARGE PRESSURE	
0° C	32° F	51.2 BAR	743 PSI
5° C	41° F	52.2 BAR	757 PSI
10° C	50° F	53.1 BAR	770 PSI
15° C	59° F	54.1 BAR	784 PSI
20° C	68° F	55.0 BAR	798 PSI
25° C	77° F	55.9 BAR	811 PSI
30° C	86° F	56.9 BAR	825 PSI
35° C	95° F	57.8 BAR	839 PSI
40° C	104° F	58.8 BAR	852 PSI

TEMPERATURE/CHARGE PRESSURE CHART

12. Close valve (E) by turning to the right (clockwise). After a few minutes open valve (E) and check the accumulator for leakage.
13. Back off the needle valve (A) on the accumulator end of the charging hose by turning it counterclockwise the maximum amount. This will prevent nitrogen from escaping from the accumulator as the hose is removed.
14. Close the valve on the nitrogen supply tank.
15. Adjust the regulator (D) to the minimum pressure setting by turning the knob counterclockwise.
16. Slowly remove the charging hose from the accumulator pressure valve.

**NOTE:** A small amount of nitrogen will escape when disconnecting the hose.

17. Snug the gas charging valve on the accumulator, remove the adapter from the accumulator.
18. Torque the gas charging valve to 20 Nm (15 pound feet)
19. Install the cap on the accumulator.
20. Remove the charging gauges from the nitrogen supply tank.

**NOTE:** A small amount of nitrogen will escape when disconnecting the hose.



## Actuating Controls

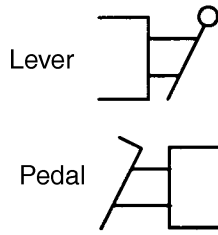

BS07B682



Two Position Controlled by External Pilot Pressure



Two Position Controlled By Solenoids

BS07B683



Three Position, Solenoid Controlled With Internal Pilot Assist Pressure

BS07B684

Valve spools are controlled by levers, pedals, pilot oil, electric solenoids, etc. which are called actuating controls. These actuating controls are shown by symbols placed on the ends of the envelopes.

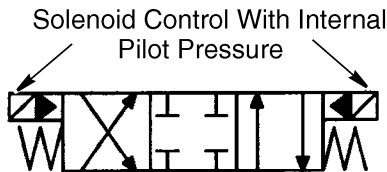

BS07B685

### THREE POSITION, SPRING CENTERED

To show that a valve is spring centered, a spring symbol is placed at each end of the envelope. The above schematic shows that an electrical solenoid and pilot pressure assist are required to overcome spring force to move the valve spool.

## Flow Control Symbols

### Restrictors



Non Adjustable Restrictor

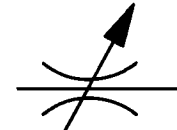

Adjustable Restrictor

BS07B686

The basic flow control symbol is a representation of a restrictor. If the restrictor is adjustable, a slanted arrow is drawn across the symbol. The restrictor could be a special fitting with a small hole in it or a small drilled passageway within a valve. If it is an adjustable restriction, it could be thought of as a water faucet that can be controlled by turning the handle to regulate the flow. Restrictors can be applied to meter out, meter in, and bleed off circuits.

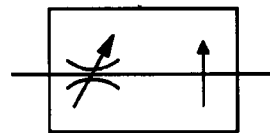

Adjustable Restrictor Pressure Compensated

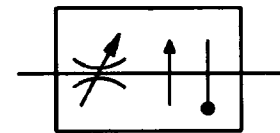

Adjustable Restrictor Pressure and Temperature Compensated

BS07B687

There are adjustable restrictors that are pressure compensated. That means that the size of the openings in the restrictor will change with increases and decreases in pressure. A perpendicular arrow indicates pressure compensation. If the restrictor has both pressure and temperature compensation, the symbol for a thermometer will also be shown.

## NOTES

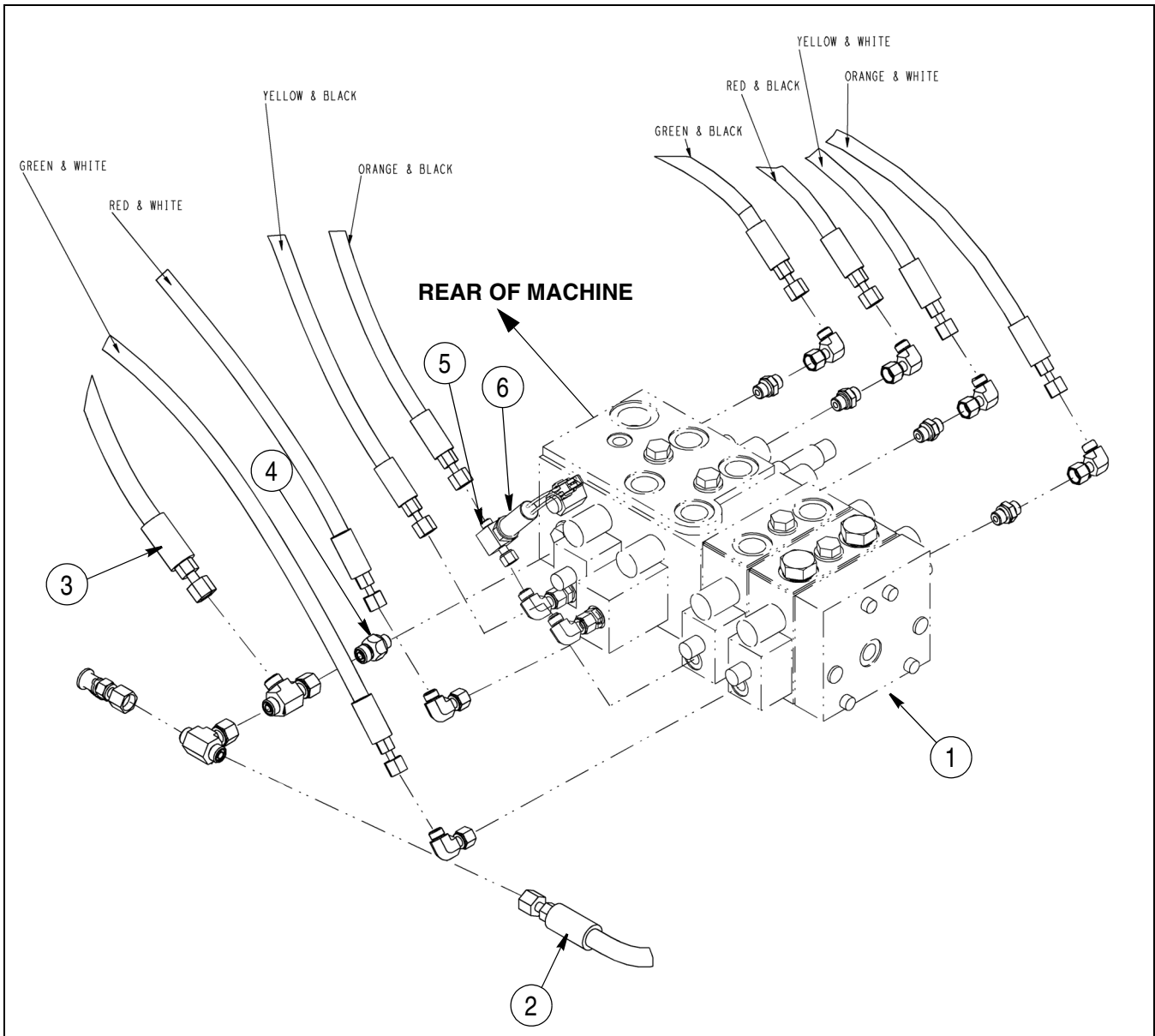

BS07H031

- |                           |   |
|---------------------------|---|
| 1. LOADER CONTROL VALVE   | 4. CHECK VALVE                                |
| 2. PILOT ACCUMULATOR HOSE | 5. SWITCH FITTING (XT WITH RIDE CONTROL ONLY) |
| 3. PILOT PRESSURE HOSE    | 6. SWITCH (XT WITH RIDE CONTROL ONLY)         |

**4 SPOOL LINE REMOVAL AND INSTALLATION ILLUSTRATION**

## HYDRAULIC PUMP

### Removal

#### STEP 55

Park the machine on a level surface and lower the bucket to the floor. Stop the engine and apply the parking brake.

#### STEP 56

Place the master disconnect switch in the OFF position.

#### STEP 57

Drain the hydraulic reservoir then refer to Section 9007 and remove the ROPS cab or ROPS canopy.

#### STEP 58

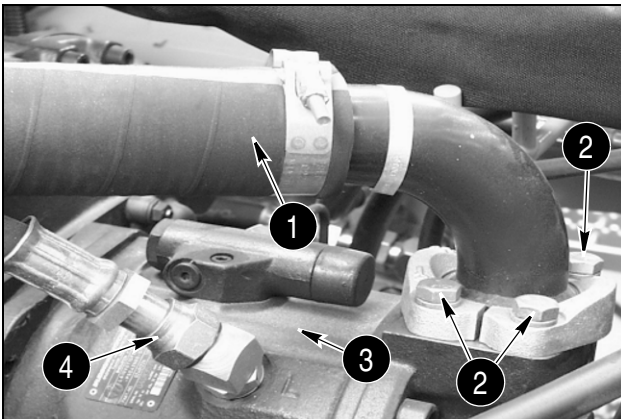

- |                 |                    |
|-----------------|--------------------|
| 1. SUCTION HOSE | 3. HYDRAULIC PUMP  |
| 2. BOLTS (4)    | 4. CASE DRAIN HOSE |

A. Loosen and remove the four bolts (2) connecting the suction hose (1) to the hydraulic pump (3).

B. Tag and disconnect the case drain hose (4) from the top of the hydraulic pump (3).

C. Plug all lines and cap all fittings.

#### STEP 59

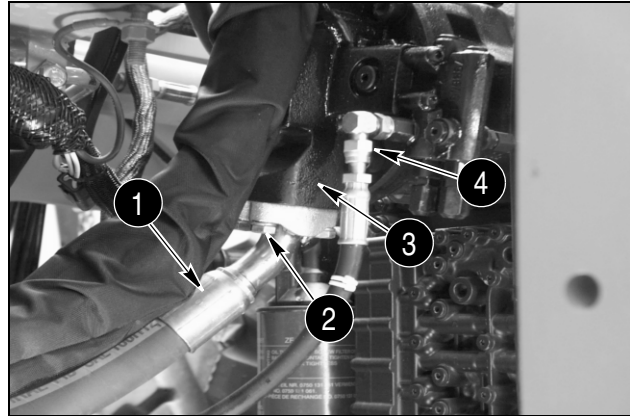

- |                  |                      |
|------------------|----------------------|
| 1. PRESSURE HOSE | 3. HYDRAULIC PUMP    |
| 2. BOLTS (4)     | 4. LOAD SENSING HOSE |

A. Loosen and remove the four bolts (2) connecting the pressure hose (1) to the hydraulic pump (3).

B. Tag and disconnect the load sensing hose (4) from the hydraulic pump (3).

C. Plug all lines and cap all fittings.

#### STEP 60

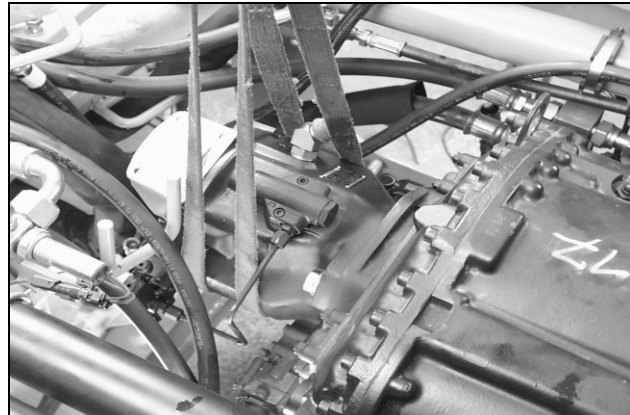

Use proper lifting device to strap and support the hydraulic pump.

**STEP 116**

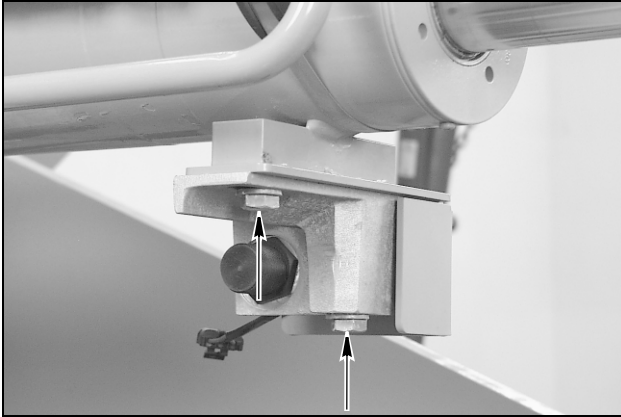

BD01D697

Install the two bolts that fasten the mounting bracket for the switch to the bucket cylinder.

**STEP 117**

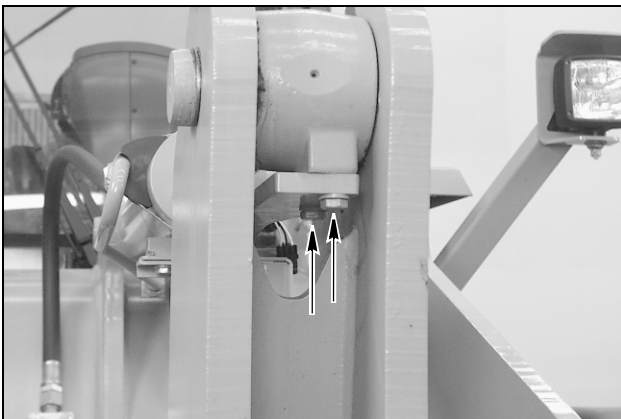

BD01D695

Install the two bolts for the mounting bracket for the target bar.

**STEP 118**

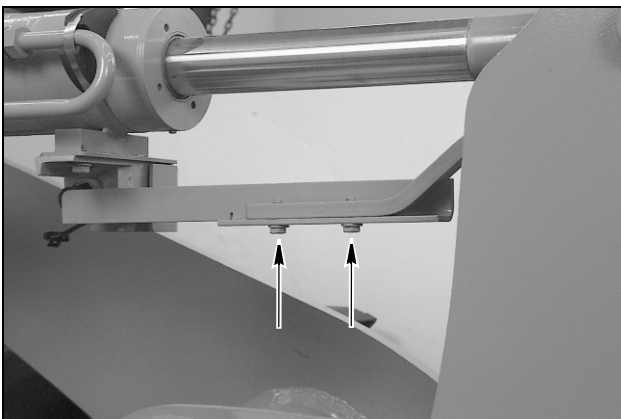

BD01D696

Install the two bolts that fasten the target bar to the mounting bracket.

**STEP 119**



BD01D694

Connect the proximity switch connector to the wiring harness connector.

**STEP 120**

See Section 9006 for the adjustment procedure for adjusting the proximity switch.

**STEP 121**

Start and run the engine at low idle.

**STEP 122**

**SLOWLY** extend and retract the piston rod three times to remove any air from the bucket cylinder.

**STEP 123**

Lubricate the pivot pins with molydisulfide grease.

**STEP 124**

Check the level of the hydraulic oil in the reservoir and add as required. Tighten the filler cap on the hydraulic reservoir.

## Installation

### STEP 187

Install the ride control valve in position on the front frame.

### STEP 188

Install the washers and bolts through the frame and into the ride control valve. Tighten the bolts.

### STEP 189

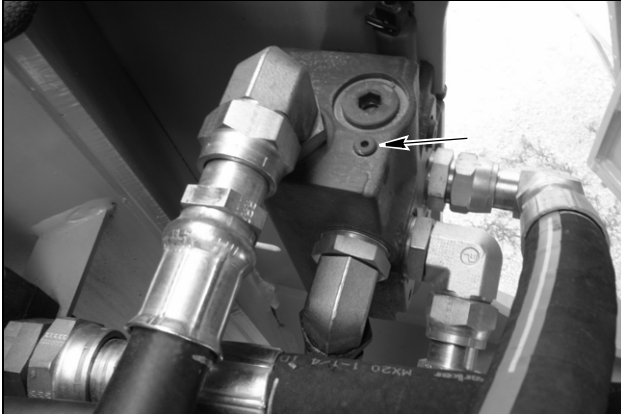

BD06F213

Tighten the accumulator manual bleeder valve located on the bottom of the ride control valve to a torque of 3.5 Nm (31 lb-in). Install the plug and torque to 7 Nm (62 lb-in).

### STEP 190

Lubricate and install new O-rings.

### STEP 191

Connect the hoses to the ride control valve.

### STEP 192

Connect the electrical connector to the ride control valve.

### STEP 193

Turn off the vacuum pump and disconnect from the hydraulic reservoir.

### STEP 194

Place the master disconnect switch in the ON position.

### STEP 195

Start and run the engine at low idle for two minutes.

### STEP 196

Stop the engine and check for hydraulic oil leakage at the ride control valve.

### STEP 197

Check the level of the hydraulic oil in the reservoir and add as required. Tighten the filler cap on the hydraulic reservoir.

### STEP 198

Put the articulation lock in the OPERATING position.

### STEP 199

Refer to Section 8002 and perform the Ride Control Test Procedure.

## Problem in a Single Loader Circuit

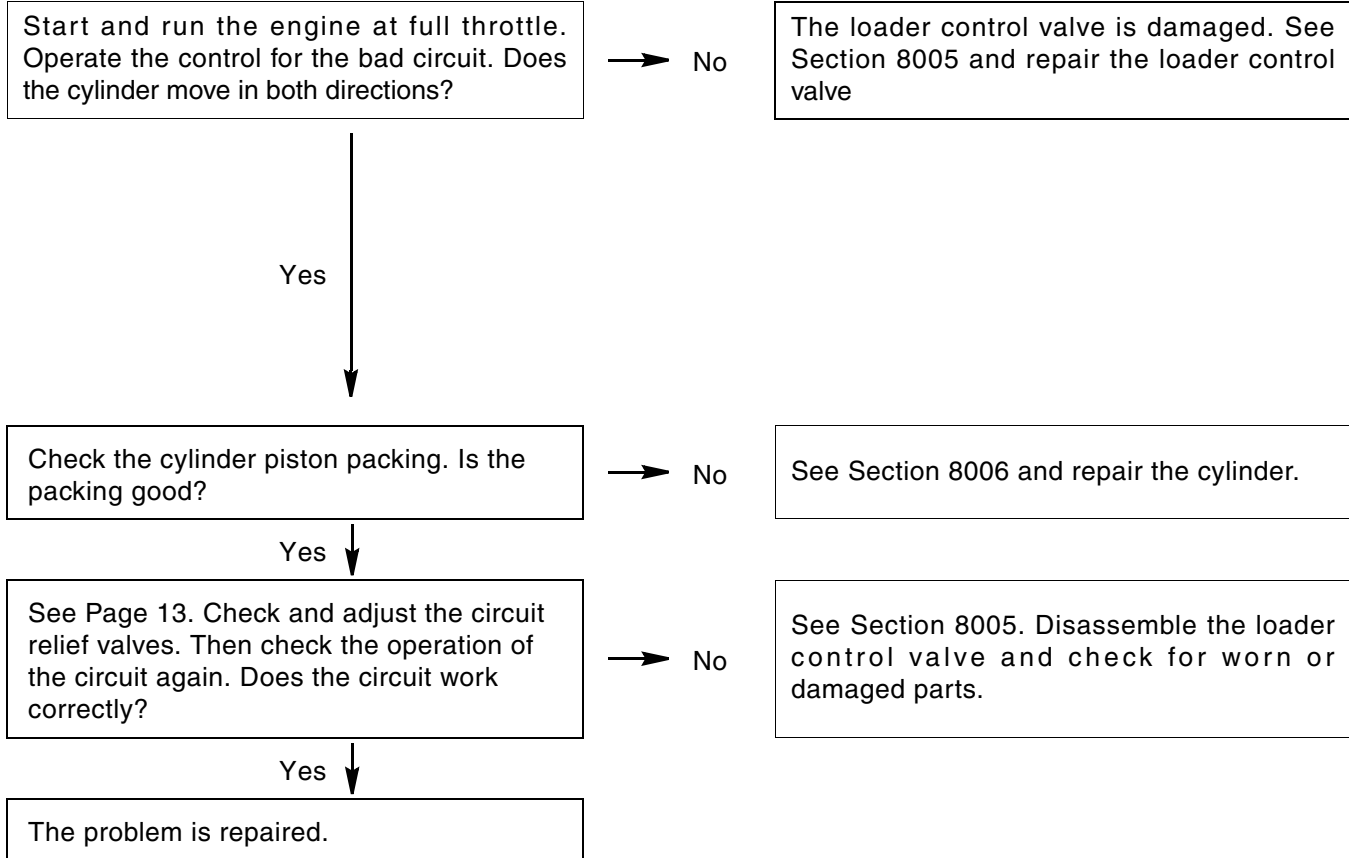

## Problem in the Steering Circuit

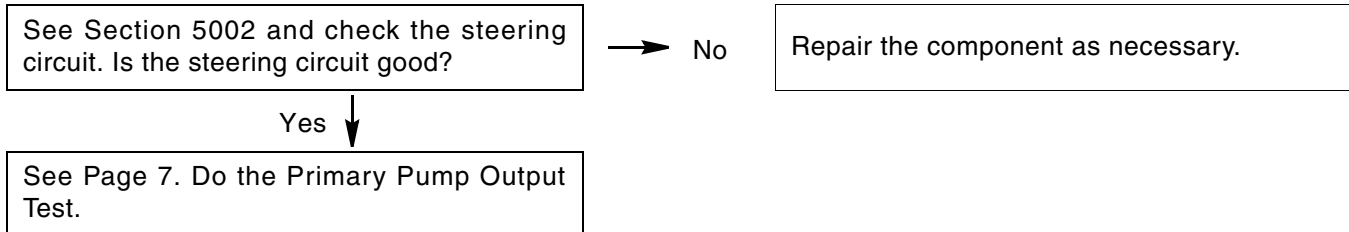

## Problem in the Ride Control

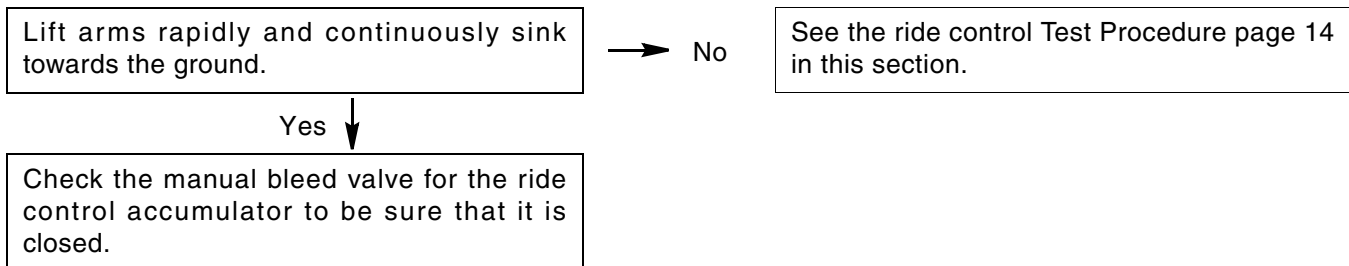

## HYDRAULIC COMPONENT LOCATIONS

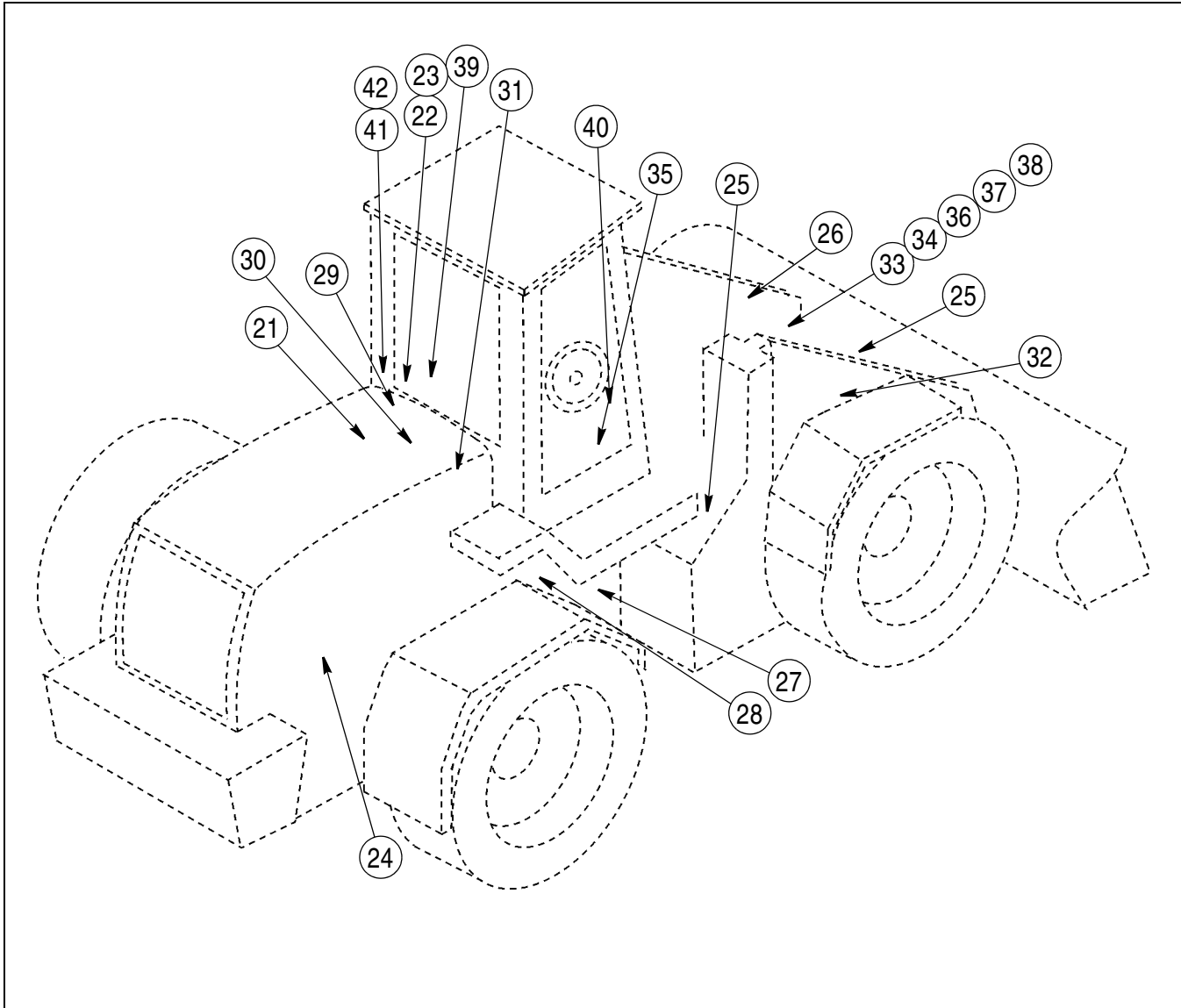

BC00N140

- |                                    |   |
|------------------------------------|---|
| 21. FAN DRIVE MOTOR                | 32. PILOT PRESSURE ACCUMULATOR                              |
| 22. FAN REVERSING VALVE (OPTIONAL) | 33. PILOT PRESSURE DIAGNOSTIC COUPLER                       |
| 23. FAN VALVE (STANDARD)           | 34. FLOAT SWITCH  |
| 24. BRAKE HYDRAULIC PUMP           | 35. CONTROLLER  |
| 25. COUPLER LOCKING VALVE          | 36. LOADER CONTROL VALVE                                    |
| 26. COUPLER LOCKING CYLINDERS      | 37. PUMP PRESSURE DIAGNOSTIC COUPLER                        |
| 27. IMPLEMENT HYDRAULIC PUMP       | 38. LOAD SENSING DIAGNOSTIC COUPLER                         |
| 28. HYDRAULIC FILTER               | 39. BRAKE PRESSURE SWITCH (2)                               |
| 29. HYDRAULIC RESERVOIR            | 40. AUXILIARY STEERING LOAD SENSE SOLENOID VALVE (OPTIONAL) |
| 30. HYDRAULIC RESERVOIR BREATHER   | 41. PARKING BRAKE ACCUMULATOR                               |
| 31. HYDRAULIC COOLER               | 42. PARKING BRAKE ACCUMULATOR DIAGNOSTIC COUPLER            |

**NOTE:** The hydraulic schematic is located in the rear pocket. All numbers are coordinated with the hydraulic schematic for reference.

## TABLE OF CONTENTS

SPECIFICATIONS .....	3
2 Spool Valve Housing Configuration .....	4
2 Spool Valve Spool Configuration .....	5
3 Spool Mounting Configuration .....	6
4 Spool Mounting Configuration .....	7
3 and 4 Spool Valve Spool Configuration .....	8
LOADER CONTROL VALVE .....	9
Disassembly .....	9
Inspection .....	12
Assembly .....	12
Circuit Relief .....	15
Pressure Test .....	15
Adjustment .....	15

## Inspection

1. Discard all O-rings, thrust rings, and spool seals.
2. Clean all parts in cleaning solvent.
3. Check the spools and the spool bores for damage and wear.

4. Check the parts of the pressure relief valve, anticavitation valves, and the anticavitation and circuit relief valves. Use new parts as necessary.
5. Inspect the other parts of the control valve. If any of the parts are damaged, install new parts.

## Assembly

### STEP 1

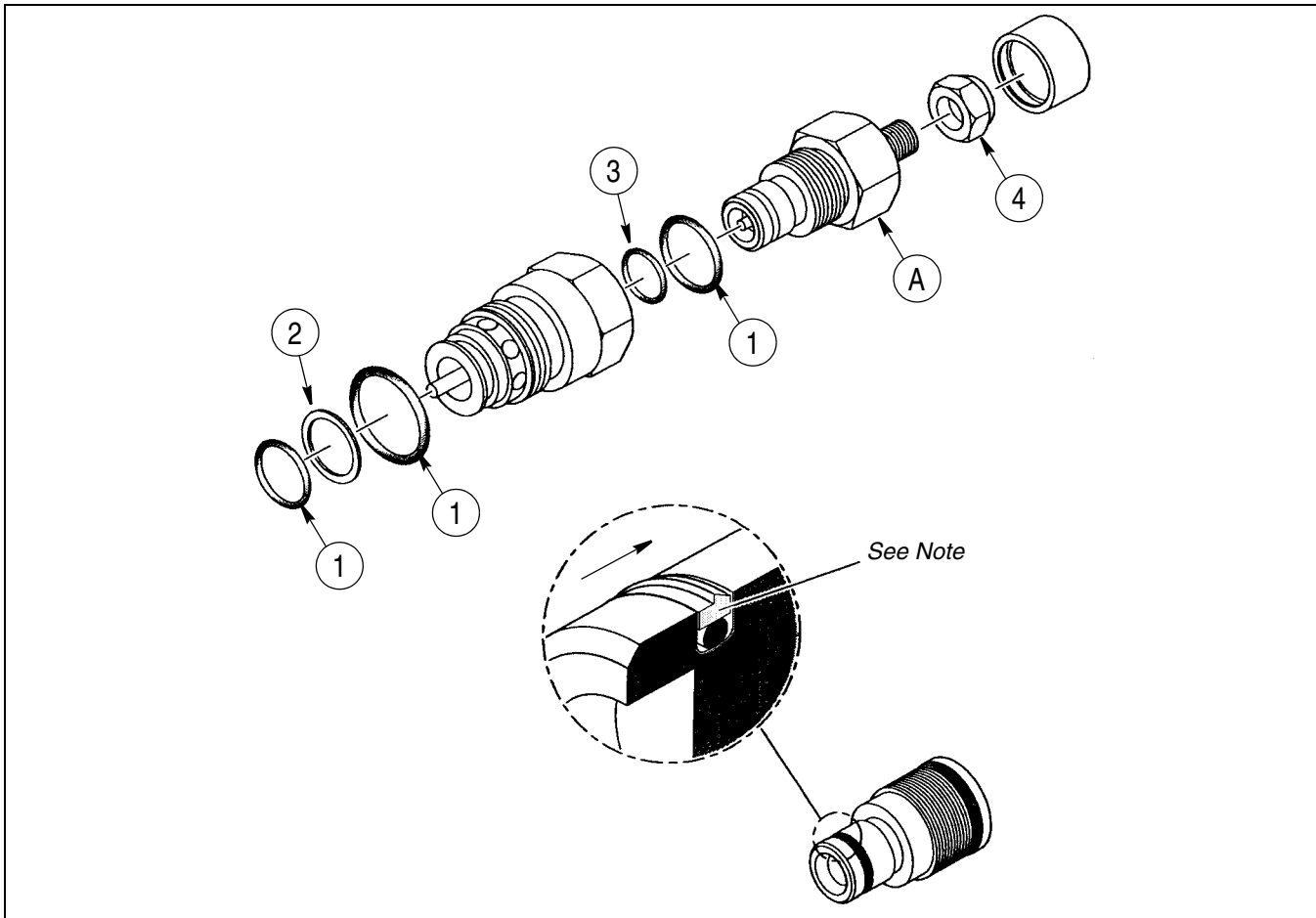

BS03C032

1. O-RINGS

2. THRUST RING

3. SPOOL SEAL

4. LOCK NUT

Install new O-rings and thrust rings on anticavitation and circuit relief valves (7 and 31). Torque relief valve (A) into anticavitation valve to 140 Nm (103 pound-feet).

**NOTE:** Spool seal mounting position is critical, seal must be mounted with lip facing as shown above, pressure is in direction of arrow.

## Assembly

**NOTE:** *If a new gland is being used, put the part number of the cylinder on the new gland.*

1. Install the bushing (8) in the gland (4), refer to Figure 1.
2. Install the seal (6) in the gland (4). The seal (6) is to be installed so that the lips of the seal (6) are toward the bushing (8). The seal (6) can be difficult to install.
3. Install the seal (7) in the gland (4). The side of the seal (7) with the groove must be toward the bushing (8).
4. Install a new wiper (5) in the gland (4). The lips of the wiper (5) must be toward the outside end of the gland (4).
5. Install a new O-ring (11) in the groove on the OD of the gland (4).
6. Install a new ring (9) in the groove on the OD of the gland (4). If both sides of the ring (9) are not flat, the side that is not flat must be toward the small end of the gland (4).
7. Install a new O-ring (10) next to the ring (9) in the groove on the outside of the gland (4). The O-ring (10) must be toward the small end of the gland.
8. Fasten the piston rod eye or yoke in the vise.
9. Remove any marks and sharp edges on the chamfer at the end of the piston rod (13). Make sure that the piston rod (13) is clean.
10. Lubricate the bore of the gland (4) and the piston rod (13) with clean oil.
11. Push the gland (4) onto the piston rod (13). If necessary, use a soft hammer to drive the gland (4) onto the piston rod (13).
12. Put a support below and near the end of the piston rod (13). Use a shop cloth between the support and the piston rod (13) to prevent damage to the piston rod (13).
13. Start the piston (15) onto the piston rod (13).
14. Clean the threads on the end of the piston rod and the threads of the piston bolt using Loctite cleaning solvent. Allow to dry. Apply Loctite 242 to the piston rod threads 1/4 inch from the open end of the piston rod so that there is 1/2 inch of Loctite 242 on the piston rod threads. **DO NOT** apply Loctite to the first 1/4 inch of the piston rod threads.
15. Install the bolt (14) into the piston rod (13). Tighten the bolt (14) to a torque of 1600 to 1830 Nm (1180 to 1350 pound-feet). A torque multiplier can be used to help torque the bolt (14).
16. Install a new wear ring (18) in the wide groove on the outside of the piston (15), refer to Figure 1.
17. Install a new ring (17) in the other groove on the outside of the piston (15).
18. Install a new seal (16) on the top of the ring (17).
19. Fasten the tube (1) in an acceptable repair stand or other holding equipment. Be careful to prevent damage to the tube (1).
20. Lubricate the inside of the tube (1) and the piston (15) with clean oil.
21. Push the piston (15) straight into the tube (1).
22. When the piston (15) is in the smooth part of the tube (1), start the gland (4) into the tube (1).
23. Lubricate the O-rings (10 and 11) on the gland (4) with clean oil.
24. If the original parts are being assembled:
  - A. Tighten the gland (4) to a torque of 135 to 542 Nm (100 to 400 pound-feet).
  - B. Install and tighten the lock screw (12) to a torque of 2.3 Nm (20 inch-pounds).
  - C. If, after tightening the gland, the lock screw (12) holes are not aligned, a new hole for the lock screw (12) must be drilled. See Step 25B.
25. If a new gland (4) or a new tube (1) are being assembled:
  - A. Tighten the gland (4) to 135 to 542 Nm (100 to 400 pound-feet).
  - B. Use a No. 27 drill bit and drill a hole half in the gland (4) and half in the tube (1). Drill to a depth of 11 mm (7/16 inch). Do not drill within 13 mm (1/2 inch) of a hole for the gland wrench.
  - C. Install and tighten the lock screw (12) to a torque of 2.3 Nm (20 inch-pounds).
26. If the hoses were removed with the cylinder, install new O-rings, if equipped, on the hose fittings. Lubricate O-rings with clean oil. Install the hoses.

**NOTES**

## Charging Accumulator With Nitrogen

**IMPORTANT:** *The four valves A, D, and E must be in the positions noted in the procedure before connecting the Nitrogen Accumulator Charging Kit to the machine or nitrogen, refer to illustration on page 5.*

1. Close the shutoff valve (D) by turning it all the way to the left (counterclockwise), refer to the illustration on page 5.
2. Close the gauge valve (E) by turning it all the way to the right (clockwise).
3. Connect the charging gauges to the nitrogen supply tank, open the supply tank valve.
4. Slowly turn valve (D) clockwise while watching the pressure gauge (B). Stop turning valve (D) when the needle on the gauge (B) reaches 10 bar (145 psi).

**NOTE:** *If the needle goes over the needed pressure, quickly open and close valve (E) and check the pressure again.*

*The charging kit is now ready to be installed on the accumulator.*

5. Remove the cap from the accumulator.
6. Loosen the sealing plug with an Allen wrench.

**NOTE:** *just loosen do not open to far so the gas leaks out*

7. Install adapter 380001168 (F).
8. Back off the needle valve (A) on the accumulator end of the charging hose by turning it counterclockwise to the maximum amount. This prevents nitrogen from escaping from the accumulator when the charging hose is attached to the accumulator gas charging valve.
9. Install the charging hose fitting onto the adapter.
10. Tighten the needle valve by turning it clockwise. Slowly open the gauge valve (E) and observe the reading on the gauge. This reading is the nitrogen pressure level inside the accumulator.
11. Fill the accumulator to pressure according to Temperature/Charge Pressure chart.

TEMPERATURE		CHARGE PRESSURE	
10° C	50° F	16.36 BAR	237 PSI
13° C	55° F	16.55 BAR	240 PSI
16° C	60° F	16.74 BAR	243 PSI
18° C	65° F	16.87 BAR	245 PSI
21° C	70° F	17.06 BAR	248 PSI
24° C	75° F	17.26 BAR	250 PSI
27° C	80° F	17.45 BAR	253 PSI
29° C	85° F	17.58 BAR	255 PSI
32° C	90° F	17.77 BAR	258 PSI
35° C	95° F	17.96 BAR	261 PSI
38° C	100° F	18.15 BAR	263 PSI

**TEMPERATURE/CHARGE PRESSURE CHART**

12. Close valve (E) by turning to the right (clockwise). After a few minutes open valve (E) and check the accumulator for leakage.
  13. Back off the needle valve (A) on the accumulator end of the charging hose by turning it counterclockwise the maximum amount. This will prevent nitrogen from escaping from the accumulator as the hose is removed.
  14. Close the valve on the nitrogen supply tank.
  15. Adjust the regulator (D) to the minimum pressure setting by turning the knob counterclockwise.
  16. Slowly remove the charging hose from the accumulator pressure valve.
- NOTE:** *A small amount of nitrogen will escape when disconnecting the hose.*
17. Snug the gas charging valve on the accumulator, remove the adapter from the accumulator.
  18. Torque the gas charging valve to 20 to 25 Nm (14.8 to 18.4 pound feet)
  19. Install the cap on the accumulator.
  20. Remove the charging gauges from the nitrogen supply tank.

**NOTE:** *A small amount of nitrogen will escape when disconnecting the hose.*

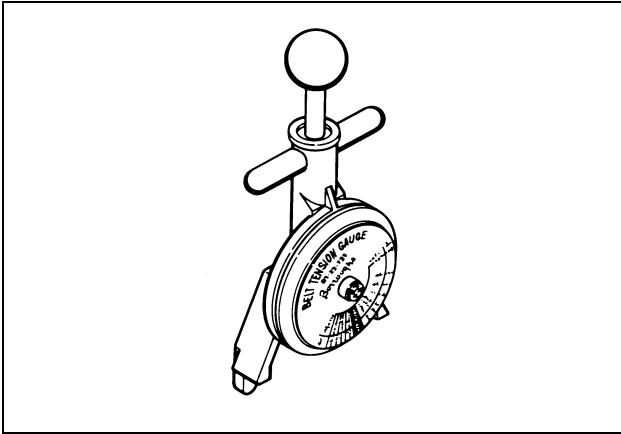

299L7C

**BELT TENSION TOOL CAS-10808**



A22094

**REFRIGERANT RECOVERY, RECYCLING AND CHARGING STATION, OEM-1415**

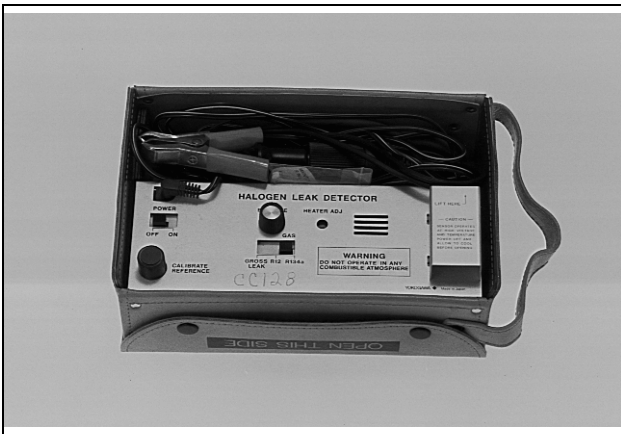

A22090

**ELECTRONIC LEAK DETECTOR OEM-1437**

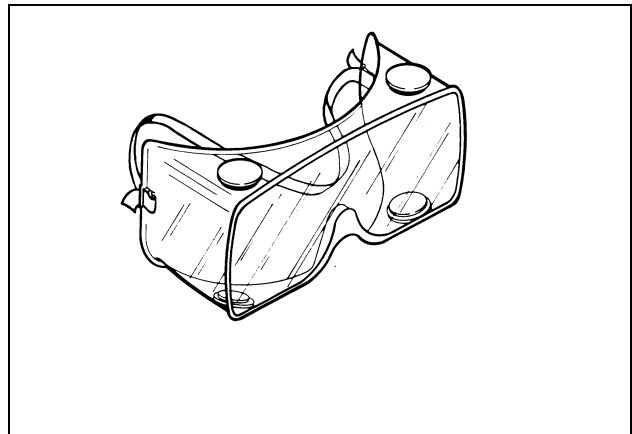

109L7

**SAFETY GOGGLES CAS-10073-3**

## PRESSURE-TEMPERATURE CHART

AMBIENT TEMPERATURE °F (°C)	NORMAL LOW PRESSURE INDICATION psi (bar)	NORMAL HIGH PRESSURE INDICATION psi (bar)	AIR LOUVER (BEHIND SEAT) MAXIMUM TEMP. °F (°C)
80 (27)	9 to 12 (0.62 to 0.83)	145 to 165 (10 to 11.53)	55 (14)
90 (32)	11 to 15 (0.76 to 1.04)	190 to 210 (13.10 to 14.48)	61 (18)
95 (35)	16 to 18 (1.10 to 1.24)	210 to 230 (14.48 to 15.86)	63 (20)
100 (38)	17 to 19 (1.17 to 1.31)	235 to 255 (16.2 to 17.58)	66 (22)
105 (41)	20 to 21 (1.38 to 1.45)	260 to 280 (17.93 to 19.31)	68 (23)
110 (43)	22 to 24 (1.93 to 2.14)	290 to 310 (20 to 21.37)	72 (25)

The pressure-temperature chart is based on the following conditions:

**NOTE:** *High humidity will cause higher air louver temperatures and dramatic increase in suction pressure. The table shown represents readings taken in low relative humidity. Adjust the chart according to local conditions.*

1. Engine at 1500 RPM, no load, fan speed & temperature control at max setting, A/C switch ON, all louvers and doors open

2. All panels and access doors installed and closed.
3. Cab filters clean and installed.
4. Heater valve at engine closed.
5. Measurements taken 15 minutes after startup.

## QUICK REFERENCE TROUBLESHOOTING CHART

PROBLEM	LOW PRESSURE GAUGE	HIGH PRESSURE GAUGE	SEE PAGE
NO COOLING	VERY LOW	VERY LOW	16
NO COOLING	HIGH	HIGH	17
NOT ENOUGH COOLING	NORMAL TO HIGH	NORMAL	19
NOT ENOUGH COOLING	LOW	LOW	20
NOT ENOUGH COOLING	HIGH	LOW	22
NOT ENOUGH COOLING	HIGH	HIGH	23
INTERMITTENT COOLING	NORMAL	NORMAL	24
NOISE IN SYSTEM	NORMAL TO HIGH	HIGH	25

## PROBLEM: INTERMITTENT COOLING

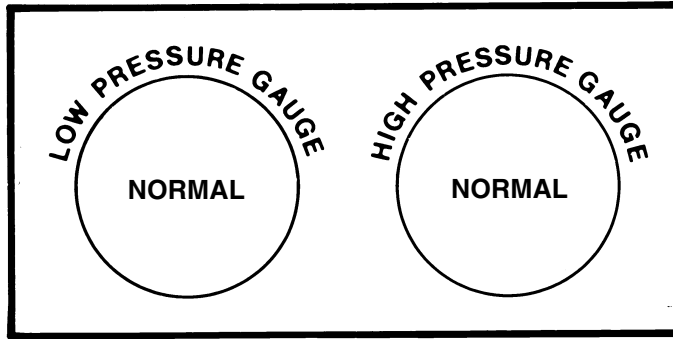

SEE PRESSURE - TEMPERATURE CHART ON PAGE 14

476L7

### Moisture in the System - Indications:

Cooling is acceptable during cool part of day but not acceptable during hot part of day.



1. Discharge system of refrigerant. If too much moisture enters the orifice of the expansion valve, the freezing of this moisture can stop refrigerant flow. See Section 9003.

2. Replace receiver-drier. The moisture removing material could be full to capacity with moisture. See Section 9004.

3. Remove air and moisture from the system. See Section 9003.

**NOTE:** *The time needed to remove a large amount of moisture will be two to three hours minimum.*

4. Charge system with new refrigerant. See Section 9003.

**STEP 13**



A22113

Program 3.75 lbs and press the enter key. The display will flash once indicating the programmed data has been accepted.

**STEP 14**



A22114

Fully open the low and high pressure valves.

**STEP 15**



A22107

Open the red (vapor) and blue (liquid) valves on the tank.

**STEP 16**

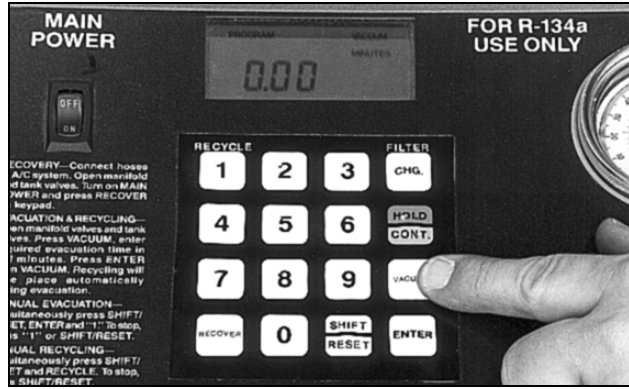

A22123

Press the Vacuum key. "Automatic" will appear on the display. Vacuum will appear on the display and after a slight delay, the vacuum pump will start. The display will show the amount of time programmed and begin a countdown to zero.

When the programmed time has elapsed, an automatic hold occurs. Check the low pressure gauge to see that the A/C system maintains a 28 to 29-1/2 inches of mercury (Hg). The low pressure gauge must not increase faster than one inch of mercury (Hg) in 10 minutes. A previously charged, leak-free system will leach refrigerant from compressor oil and raise system pressure under vacuum. If the system will not hold vacuum, a leak exists that must be corrected before recharging can begin. See Section 9002 in the manual for a leak test.

**STEP 17**



A22113

Press the charge key to begin refrigerant charging. "Automatic" and "Charge" will appear on the display. The display shows the programmed amount and counts down to zero as charging proceeds. When charging is completed, the display shows "CPL".

**STEP 14**

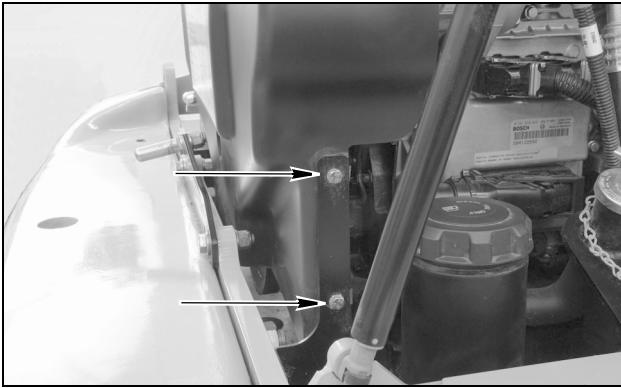

BD07N600-01

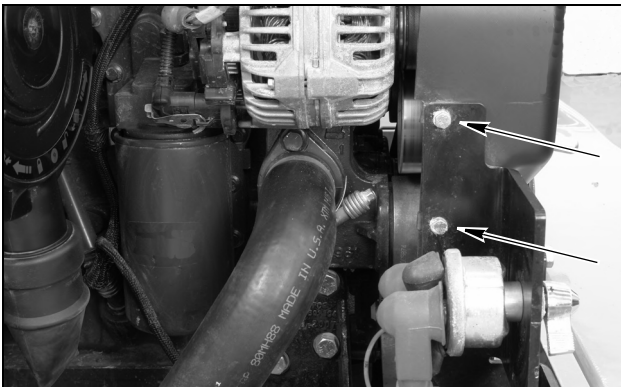

BD07N573-01

Install the belt cover, install the four mounting bolts for the belt cover.

**STEP 15**

Charge the air conditioning system according to the instructions in Section 9003.

### STEP 69

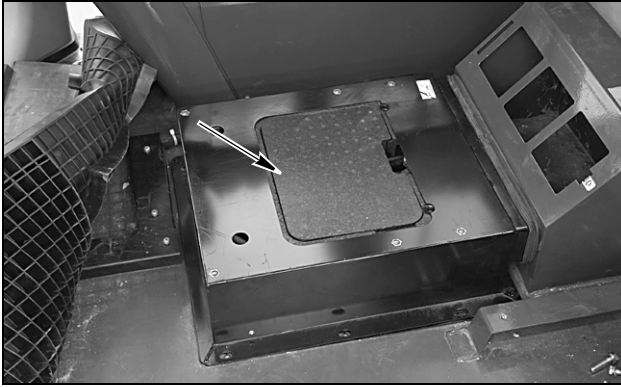

BD06G242

Install the insulation panel in the center of the upper box.

### STEP 70

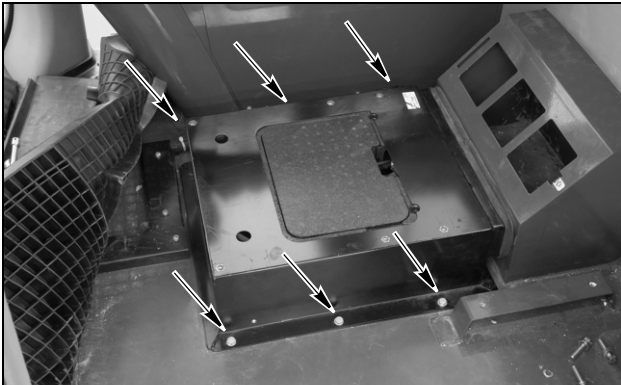

BD06G215

Install and tighten the six bolts securing the upper box.

### STEP 71



BD06G243

Install the right rear floor mat into the cab, if machine is equipped with air ride seat make sure to pull the wiring up above the mat for the seat.

### STEP 72

Install the remainder of the floor mat.

### STEP 73

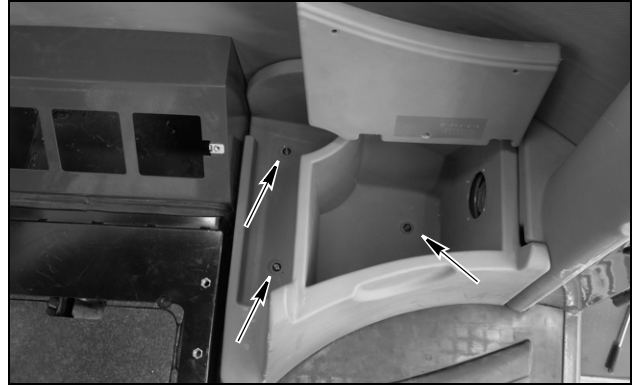

BD06G214

Install and tighten the three screws securing the cooler to the cab.

### STEP 74

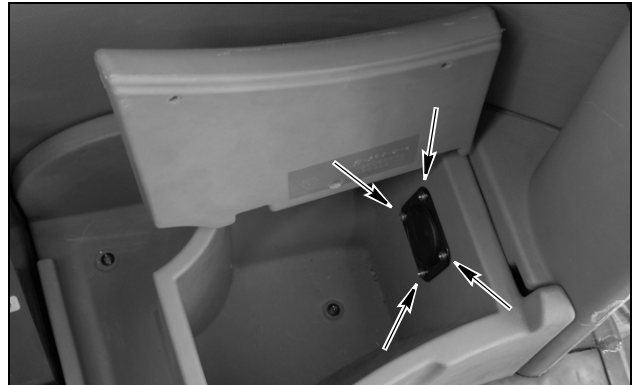

BD06G213

Install the vent cover, install and tighten the four screws securing the air vent.

### STEP 75



BD06G202

Install and torque the four bolts to 73 to 87 Nm (55 to 65 pound-feet).

## RETURN TO DIG ADJUSTMENT (XT MODELS)

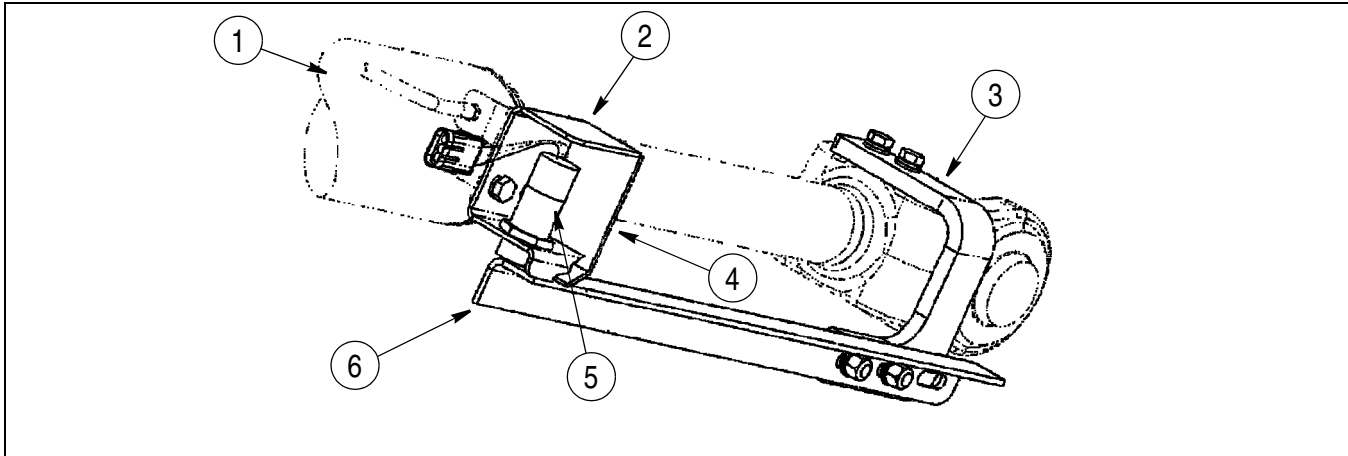

BS01C084

- |                                      |                            |                     |
|--------------------------------------|----------------------------|---------------------|
| 1. TILT CYLINDER (LEFT HAND SIDE)    | 3. TARGET MOUNTING BRACKET | 5. PROXIMITY SWITCH |
| 2. PROXIMITY SWITCH MOUNTING BRACKET | 4. PROXIMITY SWITCH GUARD  | 6. TARGET BAR       |

### RETURN TO DIG ADJUSTMENT ILLUSTRATION XT MODELS



**WARNING:** Raised equipment on the machine without an operator can cause injury or death. Before you leave the operators compartment, always support or lower the equipment (backhoe, blade, boom, bucket, etc.) to the ground and stop the engine.

CM105

**IMPORTANT:** Before adjusting the return-to-dig, make sure that the target bar on the bucket linkage is not damaged and all mounting bolts are tight. Slowly roll back and dump the bucket and make sure that the target bar stays the same distance from the switch. The switch mounting bracket protects the switch. Make sure the target bar cannot touch the switch when the bucket is dumped.

1. Park the machine on a level surface.
  2. Start the machine.
  3. Raise the lift arms until they are approximately horizontal and roll the bucket all the way back. Lower the bucket until the bucket is on the ground.
  4. Apply the parking brake and stop the engine.
  5. Loosen the bolts holding the target mounting bracket (3) to the tilt cylinder clevis. Align the target mounting bracket (3) parallel to the tilt cylinder (1) and tighten the bolts. Refer to the illustration on this page.
  6. Loosen the bolts holding the target bar (6) to the target mounting bracket (3). Align the target bar (6) parallel to the tilt cylinder (1) and tighten the bolts.
  7. Loosen the bolts holding the proximity switch mounting bracket (2) to the tilt cylinder (1). Position the proximity switch (5) face parallel to the target bar (6) and tighten the bolts.
  8. Adjust the proximity switch (5) out towards the target bar (6) until an air gap of 3.5 to 5.0 mm (1/8 to 3/16 inch) is obtained. Torque the jam nut to 6 to 7.5 Nm (4.5 to 5.5 pound-feet).
- NOTE:** The proximity switch (5) must not protrude past the proximity switch guard (4).
9. Start the engine, position the bucket flat on the ground and stop the engine.
  10. Loosen the bolts holding the target bar (6) to the target mounting bracket (3). Slide the target bar (6) away from the proximity switch (5) until the face of the proximity switch (5) is completely uncovered.
  11. Align the target bar (6) parallel to the tilt cylinder (1) and tighten the bolts.
  12. Turn the ignition switch to the ON position (not the accessory position). Do NOT start the engine.
  13. Place the bucket control lever in the full ROLLBACK position. The electromagnetic detent should hold the lever in this position.
  14. Loosen the bolts holding the target bar (6) to the target mounting bracket (3).

## NOTES

**STEP 34**

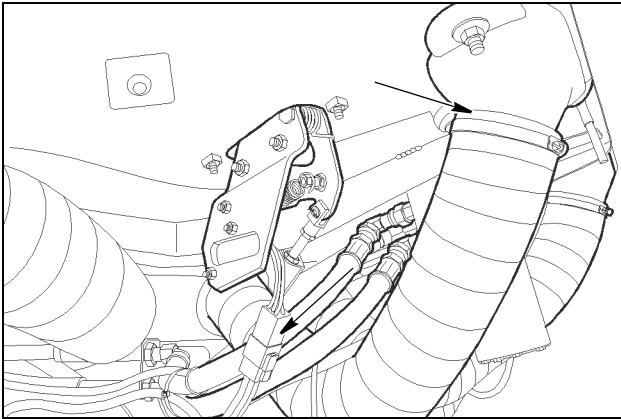

BD06G193-01

Connect throttle connector and mount air duct.

**STEP 35**

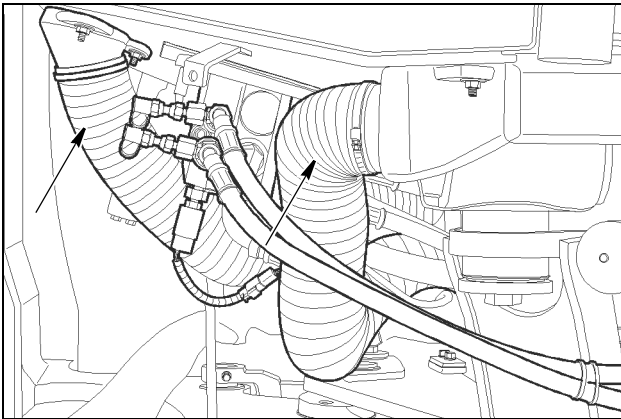

BD06G186-01

Install the ducts on the machine.

**STEP 36**

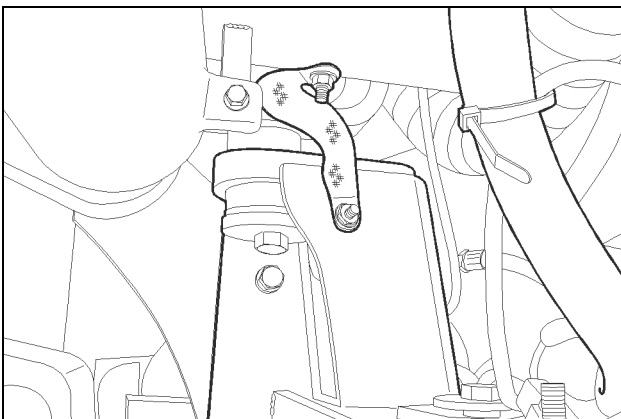

BD06G189-01

At RH rear, bottom of cab, connect ground strap to rear chassis.

**STEP 37**

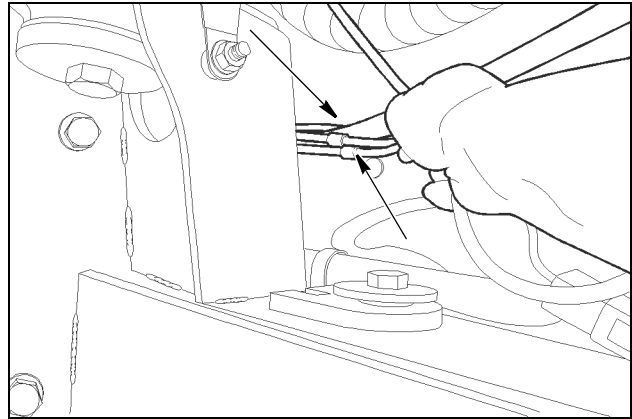

BD06G194-01

If machine is equipped with windshield washers, connect front and rear windshield washer nozzle hoses following tags installed during removal. Remove and discard tags.

**STEP 38**

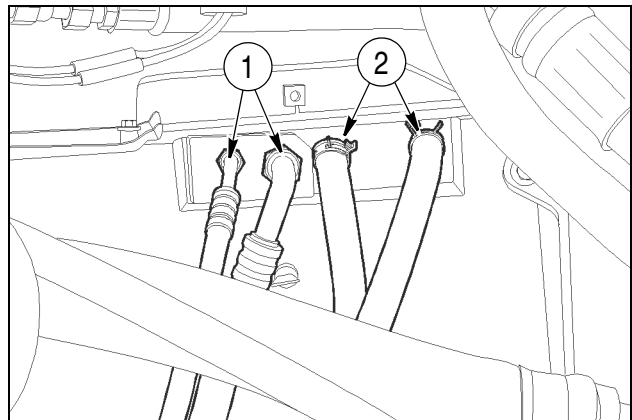

BD06G205-01

- 1. AIR CONDITIONING HOSES
- 2. HEATER HOSES

If machine is equipped with a heater, remove plugs from hoses and caps from fittings, connect heater hoses (2), if machine is equipped with air conditioning, remove plugs from hoses and caps from fittings, connect air conditioning hoses (1), charge the air conditioning system, see section 9003.

**STEP 39**

Remove plugs from hoses and caps from fittings. Connect hoses to joystick and two-lever controller and install in hose mounting grommet halves as shown on pages 11, 12, and 13.

CLICK HERE TO **DOWNLOAD** THE COMPLETE MANUAL

- Thank you very much for reading the preview of the manual.
- You can download the complete manual from: [www.heydownloads.com](http://www.heydownloads.com) by clicking the link below



- Please note: If there is no response to CLICKING the link, please download this PDF first and then click on it.

CLICK HERE TO **DOWNLOAD** THE COMPLETE MANUAL