

6

2

0



Service Manual

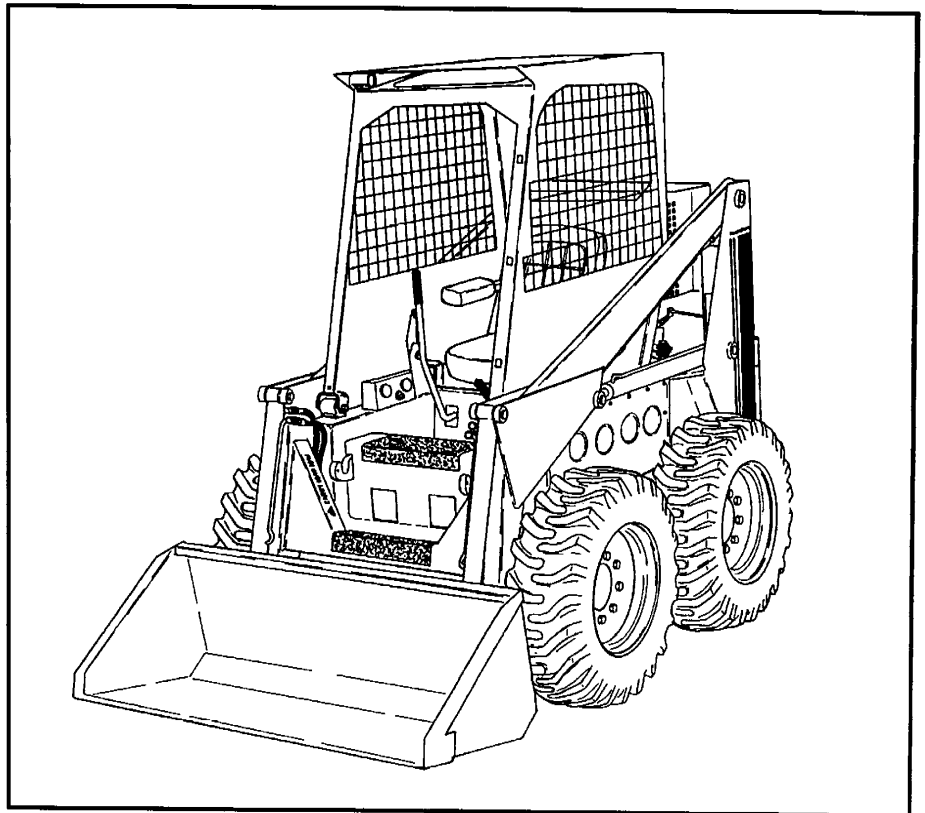

MELROE
INGERSOLL-RAND

6549846 (9-75)

Printed in U.S.A.



© Melroe Company 1996

CLICK HERE TO **DOWNLOAD** THE COMPLETE MANUAL

- Thank you very much for reading the preview of the manual.
- You can download the complete manual from: www.heydownloads.com by clicking the link below



- Please note: If there is no response to CLICKING the link, please download this PDF first and then click on it.

CLICK HERE TO **DOWNLOAD** THE COMPLETE MANUAL

1-12 CONTROLS

Steering linkage. Correct steering linkage adjustment must be made or the machine will move when the levers are in neutral. Refer to page 3-6 for adjustment.

Foot Pedal Adjustment. Correct pedal adjustment must be made to fit operator and to permit full movement of the valve spools.

To make adjustment: (Fig. 1-17)

- (1) Remove the pins from the clevis.
- (2) Turn the clevis until the adjustment is correct.
- (3) After the pedal is connected to the clevis, push the pedal with the heel. There must be 1/4" (6.5 mm) minimum clearance between the bottom edge of the pedal and the floor plate.

1-13 CHOKE LINKAGE ADJUSTMENT

- (1) Loosen the adjustment screw at the engine (Fig. 1-18).
- (2) Hold the choke control knob about 1/8" (3 mm) from full-choke position.
- (3) Hold the choke on the carburetor completely closed, then tighten the screw.

1-14 THROTTLE ADJUSTMENT

See engine section for adjustment of the governor and throttle.

WARNING

Operating the engine beyond specification for RPM will cause damage to the engine and hydrostatic system.

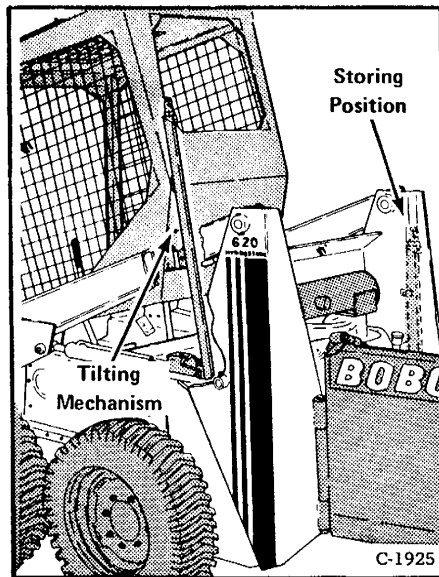

Fig. 1-15 Cab Raising Assembly

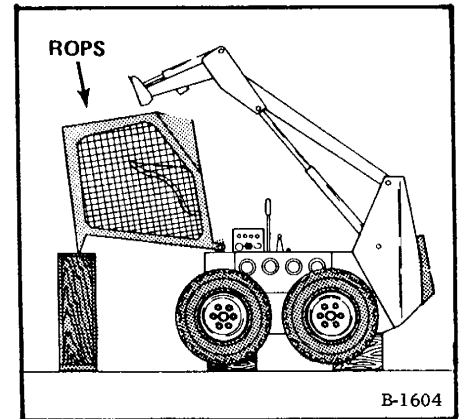

Fig. 1-16 ROPS Guard Support

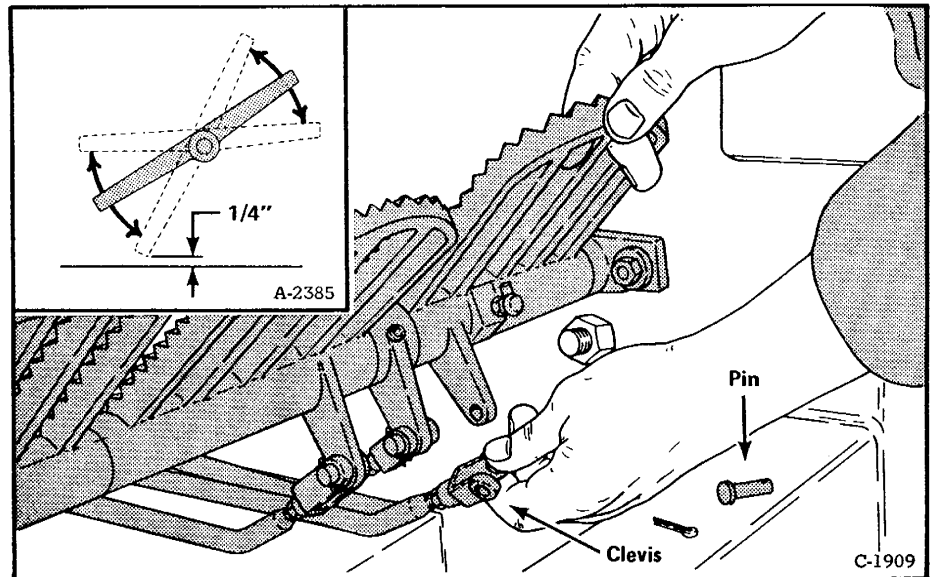

Fig. 1-17 Pedal Angle Adjustment

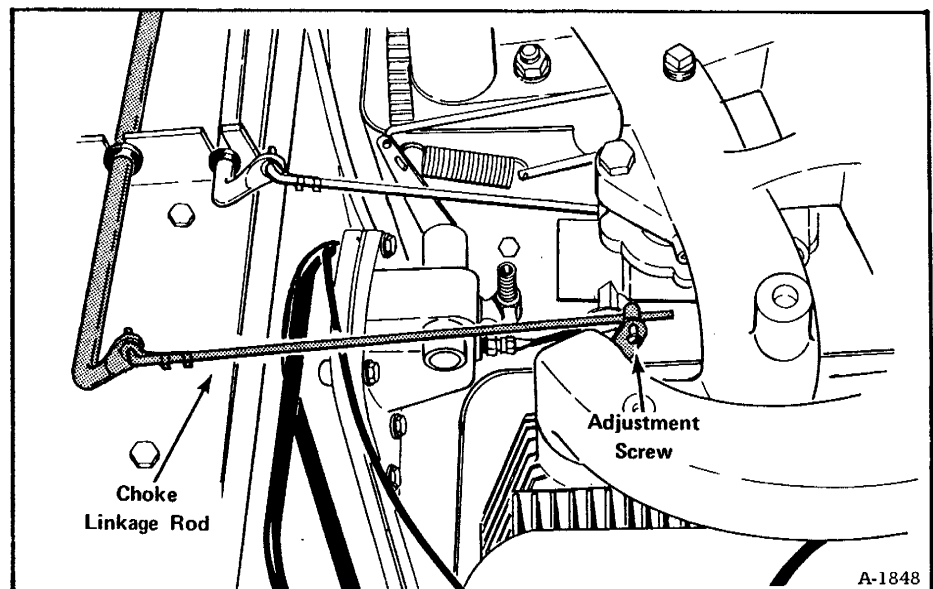

Fig. 1-18 Choke Adjustment

NOTE: This procedure may also be followed to check for leaks around axles, axle seals, etc.

(5) Install the filler plug and reservoir vents.

(6) Start the loader and run at 3/4 throttle. Operate the hydraulic controls and drive the machine for about 15 minutes. If the hydraulic action is still not smooth, repeat steps 1, 2 and 4. If no leaks can be found, make replacement of the 25 micron filter element.

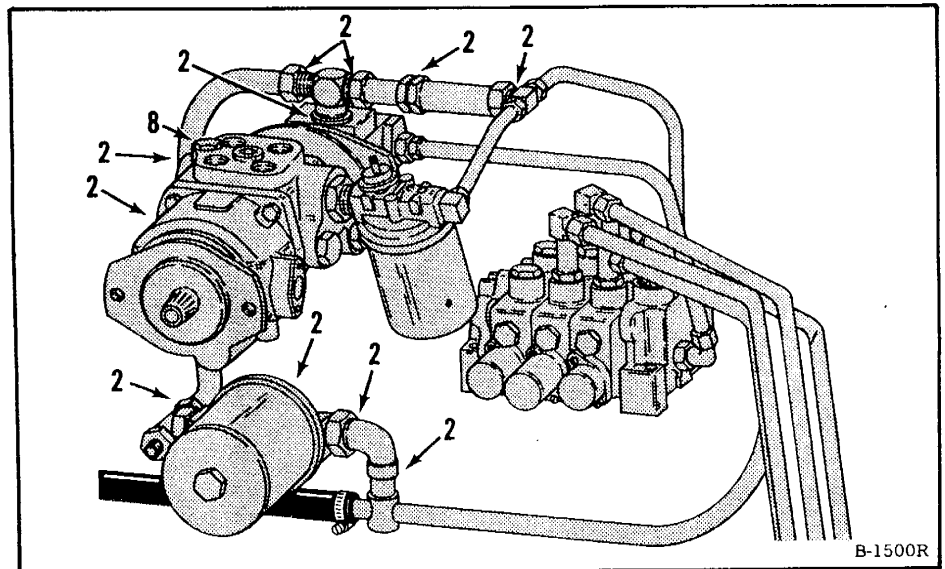

Fig. 2-8 Hydraulic System

2-5.1 Charging the Pump When No Source of Air Pressure is Available

(1) Disconnect the high pressure tube from the side of the vane pump. Disconnect the suction tube from the top of the vane pump (Fig. 2-9).

(2) Use a funnel to pour clean hydraulic fluid into the top opening. Pour until fluid flows out the side opening. Connect the tubelines to the pump.

(3) Start the engine and run at 3/4 throttle. Operate the hydraulic controls and drive the machine for about 15 minutes. If the hydraulic action is still not smooth, check the system for air leaks.

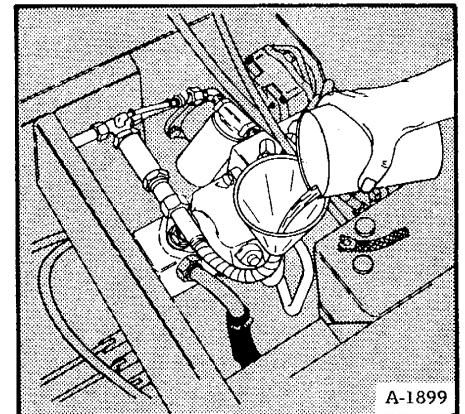

Fig. 2-9 Charging Hydraulic Pump

2-5.2 Another Method to Check the System for Air Leaks

(1) Remove the plug from the top of the valve plate (Fig. 2-8, Item 8).

(2) Put a fitting in the valve plate and connect a clear hose to the end of the fitting. Put the other end of the hose in the reservoir filler pipe.

(3) Start the engine and operate at 3/4 throttle. Operate the hydraulic controls and drive the machine for about 15 minutes, while looking at the clear hose. If air bubbles can be seen in the hose after 15 minutes, there is an air leak. Check the places shown (Item 2) for loose or damaged connections. Repair as necessary and check again. If no leaks can be found and hydraulic action is not smooth, make replacement of the 25 micron filter.

3 HYDROSTATIC DRIVE SYSTEM

3-1 Circuit Description

The check valve holds the fluid at the 10 micron filter above 50 PSI. The pressure sender on the filter base gives warning to the operator ("Tran" Light) if the pressure is low (Fig. 3-1).

A small amount of this fluid is used to keep the hydrostatic pumps and motors full of oil. It goes into the system through the replenishing valves (Fig. 3-2).

The remainder of the fluid goes out through the charge relief valve, and back to the hydraulic system. A fluid temperature sending switch is located under the front hydrostatic pump. It gives warning to the operator ("Tran" Light) if the hydraulic oil gets too hot.

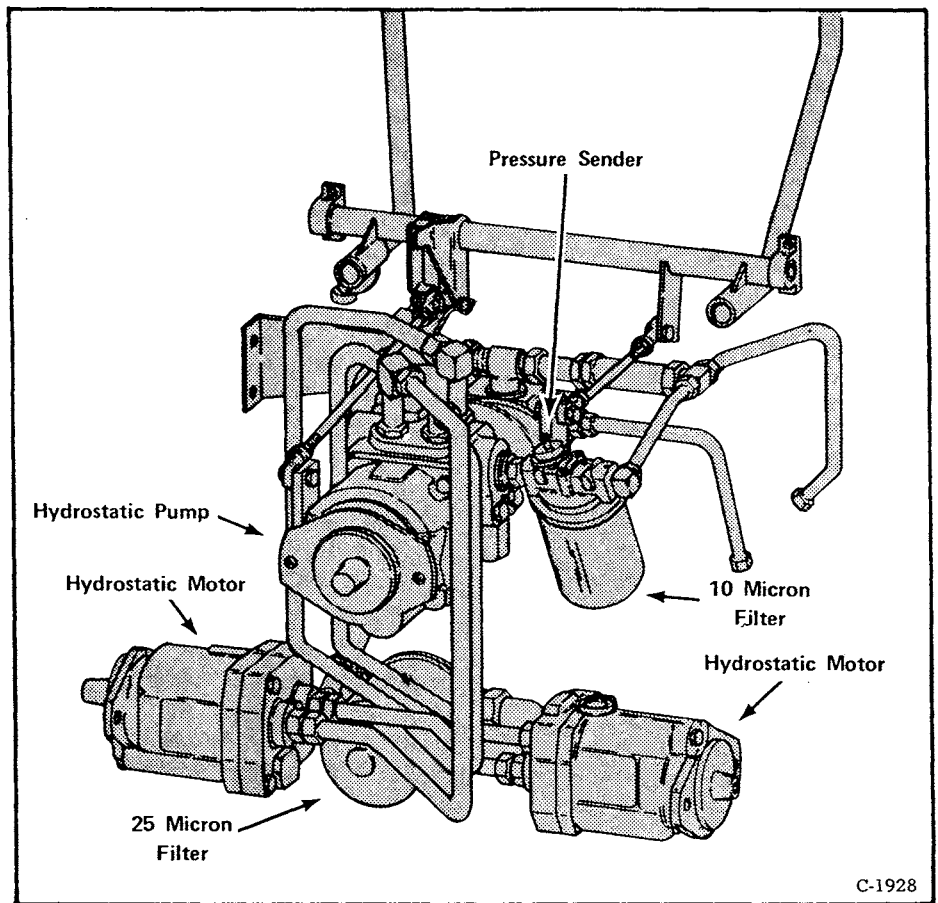

Fig. 3-1 Hydrostatic Transmission Circuitry

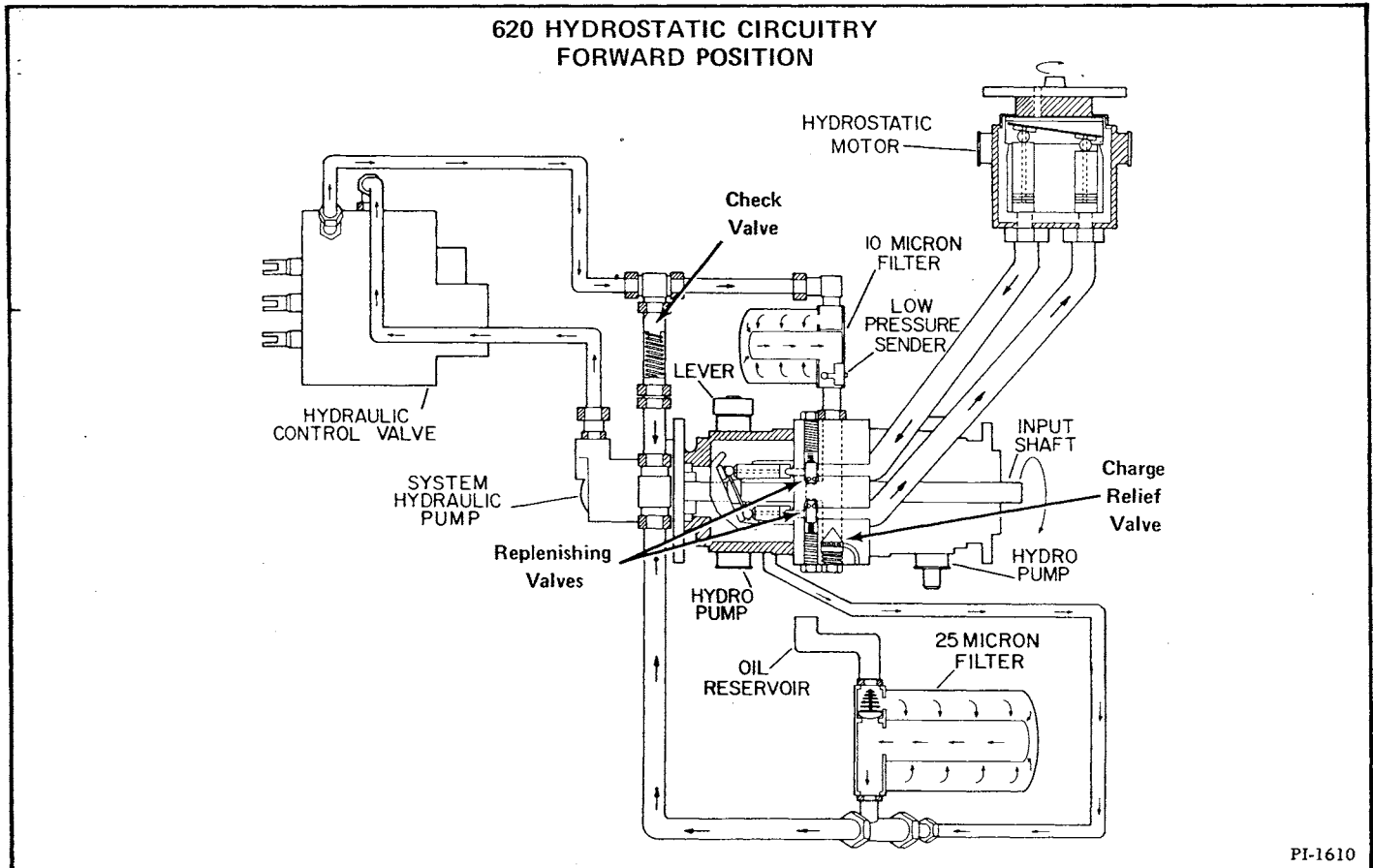

Fig. 3-2 Hydrostatic Transmission Flow Diagram

3-10 HYDROSTATIC TRANSMISSION RECONDITIONING PROCEDURE

NOTE: Thorough cleanliness is needed when working on hydrostatic systems. Always work in a clean area. Dirt in the system can cause permanent damage.

3-10.1 Transmission Pump

Separate the pumps from the transmission assembly by removing the four bolts which hold the pumps to the valve plate. A shaft coupling connects the front and rear pumps. The vane pump can be removed by removing the two fastening bolts. (See Fig. 3-15 for parts illustration.)

Be careful to not let scratches get on the valve plate surface, as this will damage the pump assembly.

Disassembly of Pumps and Motors

Disassembly of motors is similar to pumps.

Fixed displacement motors do not have:

- (1) Pintles, pintle bearings and seals
- (2) Yokes
- (3) Small snap ring

Figure 3-16 shows fixed and variable hydrostatic motors. Do not mix pump and motor parts.

3-10.2 To Disassemble Pump or Motor

- (1) Valve Plate: Remove the four bolts. Carefully separate motor or pump from plate (Fig. 3-17).
- (2) Use snap ring pliers to remove the snap ring that holds the bearing sleeve on the shaft (Fig. 3-18).
- (3) Slide the bearing sleeve off the shaft (Fig. 3-19).
- (4) Carefully remove the rotating group.

Hold the complete cylinder block and piston shoe assembly together to prevent separation while removing from the unit (Fig. 3-20).

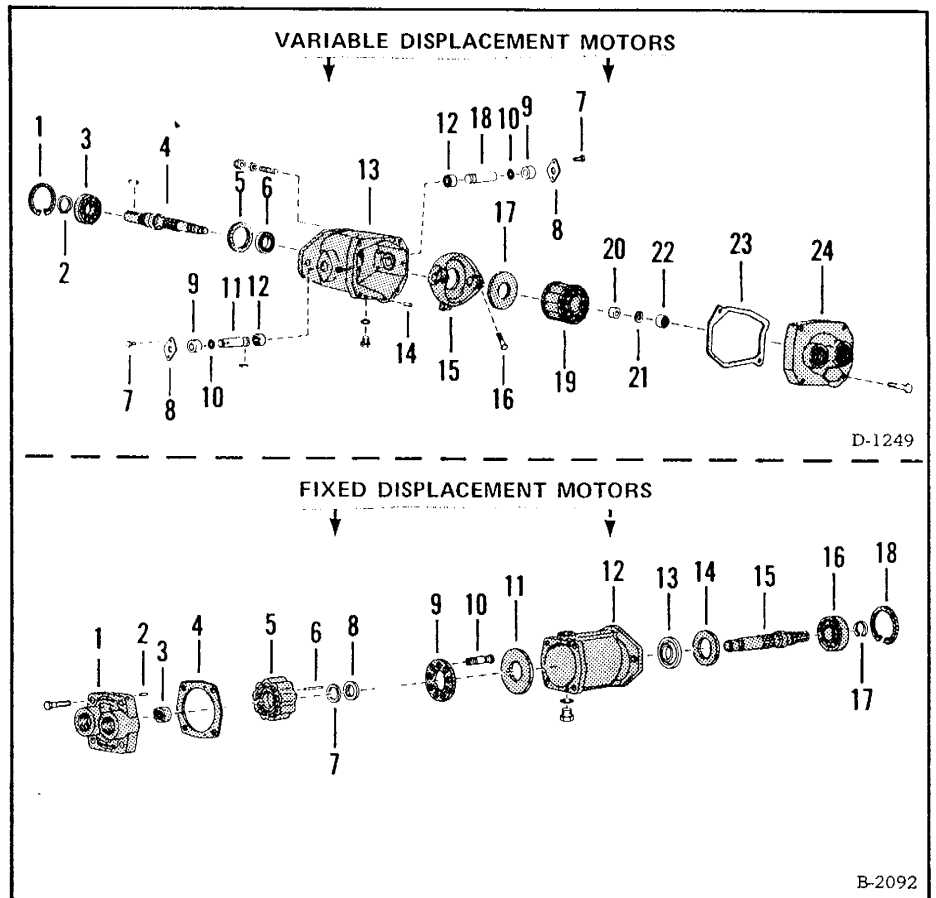

Fig. 3-16 Hydrostatic Motor Parts

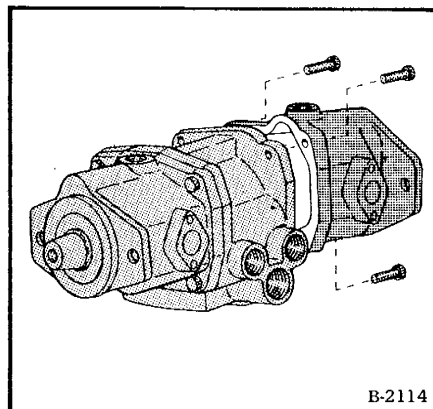

Fig. 3-17 Separating Pump From Motor

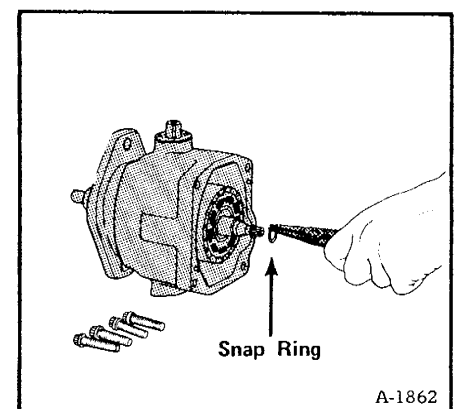

Fig. 3-18 Snap Ring Removal

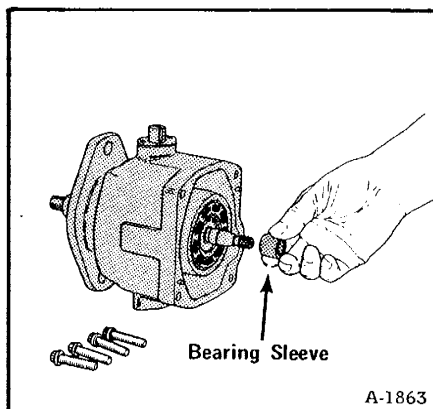

Fig. 3-19 Bearing Sleeve Removal

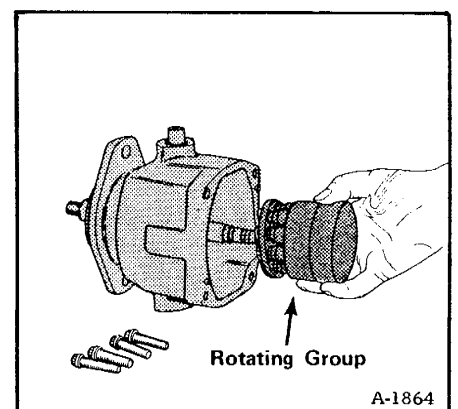

Fig. 3-20 Removing Rotating Group

4-3.2 To Install the Primary Drive Chain

- (1) To install the primary drive chain, reverse the above procedure.
- (2) See Section 1 for adjustment.

4-3.2 Secondary Drive Chain Removal

- (1) Turn the drive system until the connector link is between the sprockets.
- (2) Loosen the idler bracket, install the breaker tool and remove the connector link.
- (3) Remove the chain.

4-3.4 To Install the Secondary Drive Chain

- (1) Make a hard wire clip, about 8" long (Fig. 4-8).
- (2) Hold one end of the chain and let the remainder fall into the reservoir, near the sprocket.
- (3) Put the chain on the large lower jackshaft sprocket and install the wire clip as shown in figure 4-9.
- (4) Rotate the drive system pulling the chain onto the sprocket until the wire clip end comes into view.
- (5) Fit the other end of the chain around the idler and upper jackshaft sprockets.
- (6) Connect the two chain ends with a new connector link.
- (7) See Section 1 for adjustment.

4-3.5 Final Drive Chain Removal

NOTE: Use care when removing the final drive chain so that the chain end does not fall and double up between the wheel sprocket and end of the tank (Fig. 4-10). If the loose chain gets between the sprocket and tank end, it will be necessary to remove the axle and sprocket to remove the chain.

- (1) Rotate the drive until the connector link is in position as shown (Fig. 4-11).
- (2) Loosen the idler adjustment nuts and lift the rod up and out of the way.
- (3) Use a chain breaker tool to remove the connector link.

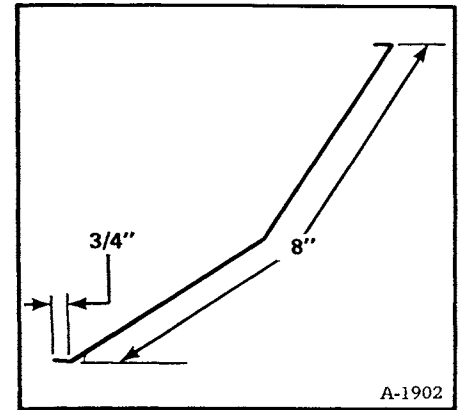

Fig. 4-8 Wire Clip

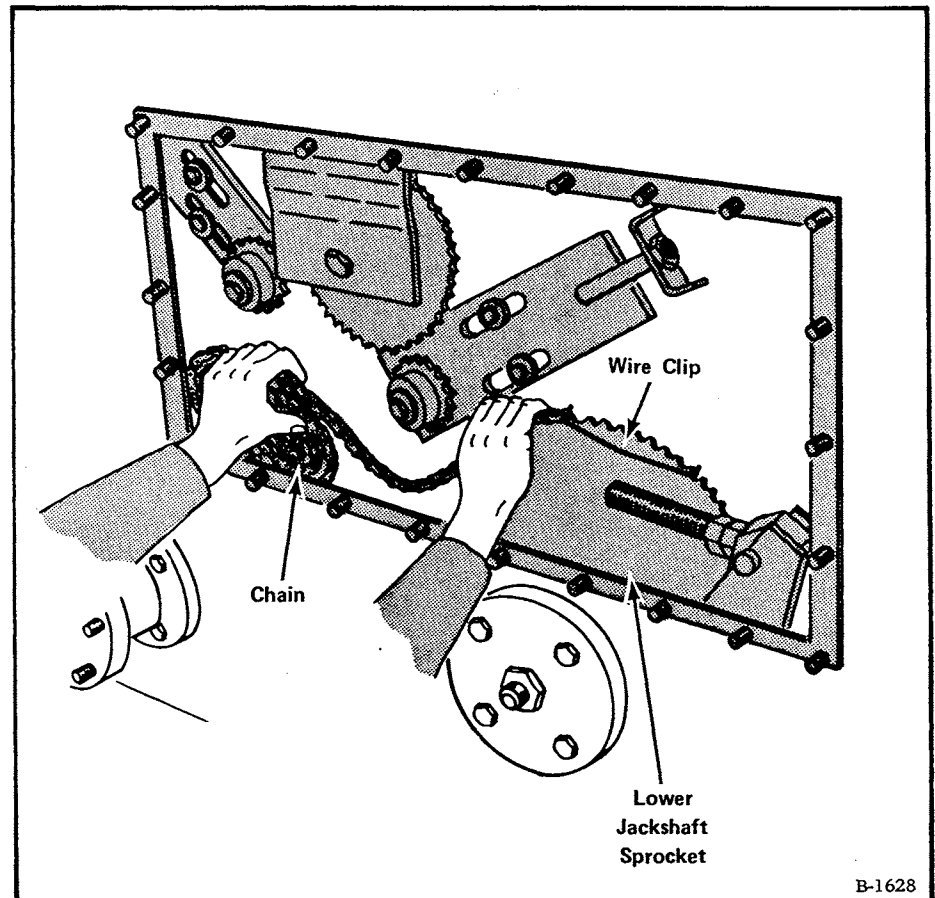

Fig. 4-9 Installing Secondary Chain

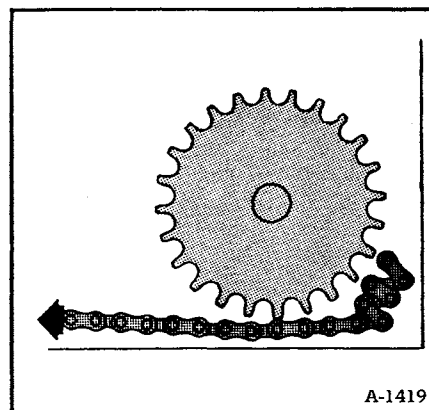

Fig. 4-10 Chain Falling Behind Sprocket

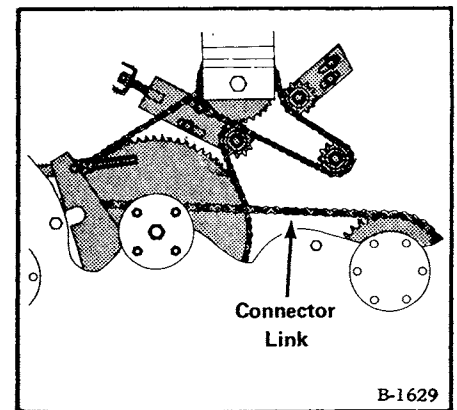

Fig. 4-11 Final Drive Chain

5 MAIN FRAME

5-1 THE BOB-TACH

Make replacement of worn or damaged Bob-Tach engaging wedges (Fig. 5-1). Also inspect the compression springs for damage.

Check the operation of the levers. The levers must go overcenter when they are pushed down (Fig. 5-2). The wedges must be fully extended when the levers are in engaged position.

Be sure the lever stopping points are in place. Otherwise the levers may damage the tilt cylinders (Fig. 5-2).

5-1.1 Removal and Replacement of Bob-Tach

- (1) Remove the attachment from the Bob-Tach.
- (2) Remove the 3/8" bolts which hold the pivot pins to the Bob-Tach, and push the pins out.
- (3) Assembly is the reverse of disassembly.

5-2 LOADER LIFT ARM ASSEMBLY

The 620 uses a one-piece lift arm. The only service that can be done is the replacement of pivot bushings at the ends (Fig. 5-3).

5-2.1 Replacement of Lift Arms

- (1) Activate the foot pedals to release pressure from hydraulic lines.
- (2) Remove the tubeline clamps which hold the hoses and tubelines to the lift arms.
- (3) Remove the tilt cylinder pins. Put the tilt cylinders on the foot pedal assembly. Leave hoses connected.
- (4) Remove the Bob-Tach pivot pins and remove the Bob-Tach.
- (5) Remove the lift cylinder pivot pins from the lift arms.
- (6) Hold the lift arms with a chain hoist and remove the pivot pins which connect the lift arms to the upright. Remove the lift arms.
- (7) Installation is the reverse of removal.

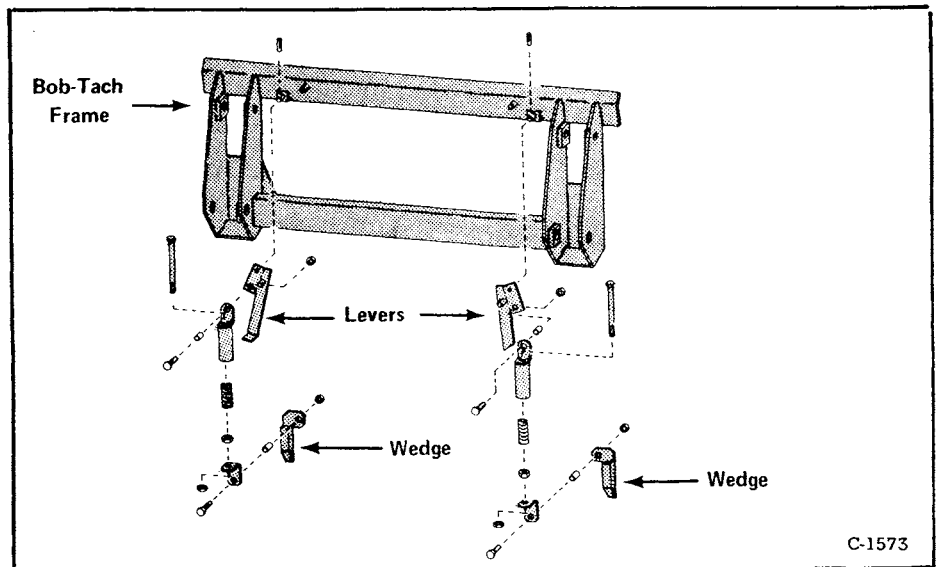

Fig. 5-1 Bob-Tach Breakdown

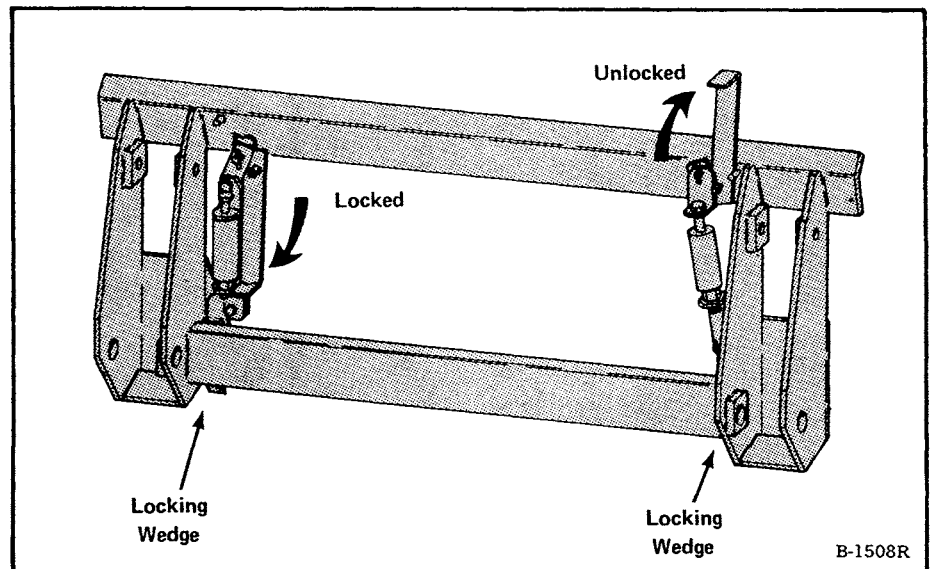

Fig. 5-2 Bob-Tach Locking Levers

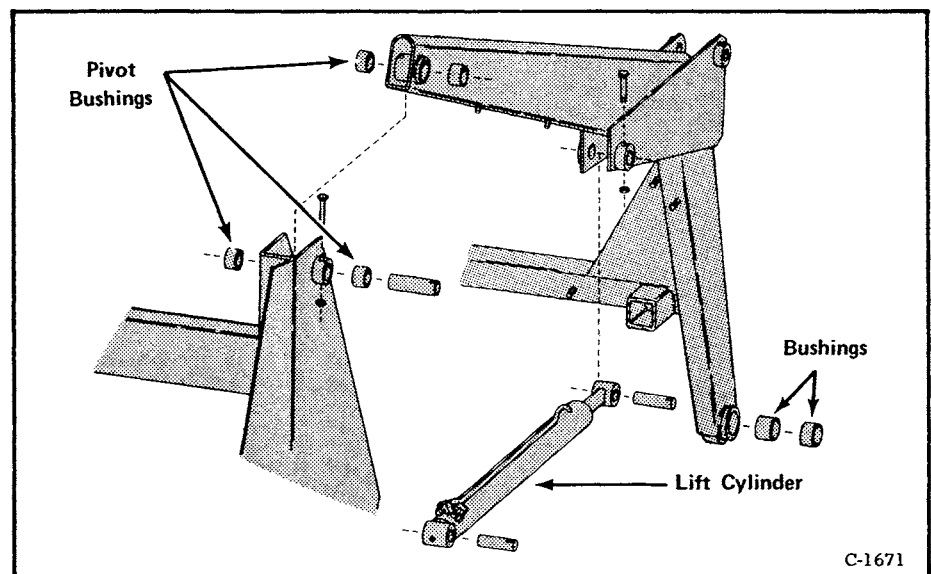

Fig. 5-3 Lift Arm Assembly

WISCONSIN ENGINE SERVICE

	Paragraph Number	Page Number
CARBURETOR SERVICE	7-3	7-3
ENGINE IGNITION SYSTEM	7-2	7-2
ENGINE SERVICE	7-7	7-11
LP CARBURETOR SERVICE	7-4	7-6
LP FUEL FILTER LOCK-OFF	7-6	7-11
TROUBLESHOOTING THE ENGINE	7-1	7-1
VAPORIZER - PRIMARY REGULATOR	7-5	7-8

ENGINE SERVICE

7-5.1 DISASSEMBLING THE VAPORIZER

See figure 7-20 for parts identification and follow the steps below:

- (1) To remove the heat exchanger, hold the vaporizer in a vise and remove the 1/4" brass nut (Item 25).
- (2) Remove the inlet orifice retainer (Item 11) and aluminum washer (Item 12) from the inlet bore.
- (3) Loosen the locknut (Item 3) on the adjustment screw (Item 2) and turn the screw in all the way to depress the inlet valve seat. The valve seat in its normal position prevents the removal of the inlet orifice (Item 13).
- (4) Turn a 1/4" - 20 screw into the inlet orifice block and remove the block (Item 13).

WARNING

The Spring loaded inlet valve seat must be fully pressed in during this operation to prevent damage to both the seat and orifice block.

- (5) Remove the pressure adjustment screw (Item 2) and spring (Item 4).
- (6) Remove the six diaphragm cover screws (Item 5) and the diaphragm cover (Item 6).
- (7) Lift the rubber diaphragm (Item 9) with the assembled piston from the bore. Remove the screw (Item 7) that holds the diaphragm and retainer to the piston.
- (8) Turn the vaporizer assembly (Item 15) and remove the inlet valve seat and retainer spring and valve cap (Items 16 & 19).
- (9) Remove the large O-ring (Item 21) from its groove on the outside of the vaporizer housing.

7-5.2 ASSEMBLING THE VAPORIZER

- (1) Put a new diaphragm (Item 9) over the piston (Item 20) and put the retainer (flange up) on the diaphragm. Hold the parts with the screw but do not tighten at this time.
- (2) Check the condition of the inlet orifice (Item 13). If it is damaged at the orifice shoulder, install a new orifice.
- (3) Install the inlet orifice block into its bore temporarily. This part has a slot and fits on a dowel pin in the bore to prevent the part from being installed wrong.
- (4) Put the assembled diaphragm and piston into the bore (Fig. 7-21) so that the piston fits over the inlet orifice block without contacting it.
- (5) Make alignment of the six screw holes of the diaphragm with the holes in the vaporizer head and tighten the diaphragm (Fig. 7-21). Hold the diaphragm and retainer to keep them from moving when tightening the screw.
- (6) Remove the assembled diaphragm and piston and the inlet orifice block from their bores after correct alignment has been made.
- (7) Check the inlet valve seat. If the disc is damaged or badly worn, make replacement of the complete unit.

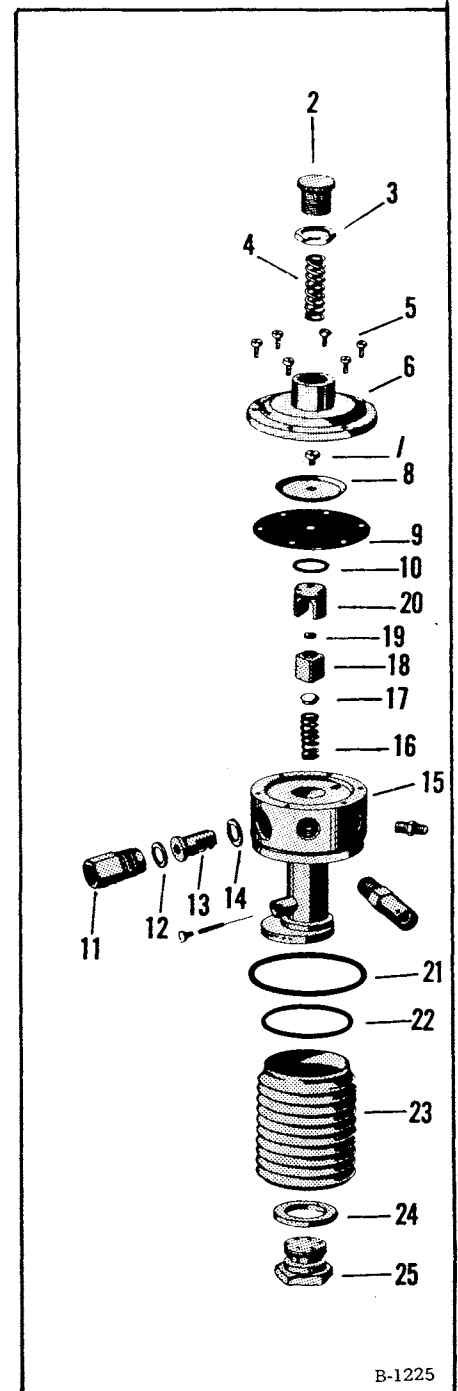

Fig. 7-20 Vaporizer Breakdown

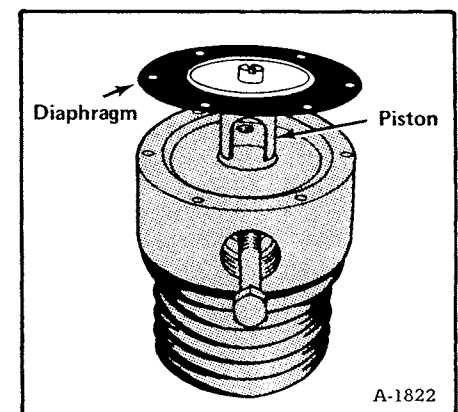

Fig. 7-21 Aligning Piston

8 SPECIFICATIONS, SPECIAL TOOLS, ETC.

8-1 FUEL SPECIFICATIONS

NOTE: Do not use premium grade gasoline in the Wisconsin engine.

Either regular or leaded gasoline may be used, with a minimum octane rating of 85.

The capacity of the fuel tank is 12.5 gallons (47.3 litres).

8-2 ENGINE OIL SPECIFICATIONS

Check oil level after every 8 hours of operation (Check oil every 4 hours on new engine during the first 50 hours of operation).

Oil level must always be kept between the "add" and "full" mark on the dipstick. Use a good quality detergent motor oil that meets the API service specifications indicated below.

Use oil of correct SAE viscosity for expected temperature conditions at the time of starting, not for the highest temperature expected during the working day.

GRADE OF OIL (WISCONSIN ENGINE)	
SEASON OR TEMPERATURE	GRADE OF OIL
Spring, Summer or Fall +120°F. to +40°F. (48°C. to 5°C.)	SAE 30
WINTER +40°F. to +15°F. (5°C. to -9°C.) +15°F. to 0°F. (-9°C. to -18°C.) Below Zero (-18°C.)	SAE 20 - 20W SAE 10W SAE 5W - 20
OIL QUANTITY	
Use Oils Classified as Service SC-SE	
New Engine	4 Quarts
Oil and Filter Change	4 Quarts
Without Filter Change	3-1/2 Quarts

Follow summer recommendations in winter if engine is kept in warm facility.

WARNING

Never overfill the engine with oil.

8-3 HYDRAULIC/HYDROSTATIC TRANSMISSION FLUID

The hydraulic system capacity is 20 gallons. The transmission reservoir capacity is 17 gallons when filled to the upper check plug at the left side of the machine.

The 620 Bobcat hydraulic/hydrostatic system reservoir must be filled only with fluids which will protect the transmission components. For operation in temperatures from below freezing up to hot climate conditions, use Texaco Rando Oil No. 1627 HD-AZ or fluids which meet the chemical performance characteristics of Rando oil. Any 10W-30 oil which meets API classification SC, SD, or SE may be added to the Rando oil when adding to the reservoir. These types of oils become thicker at lower temperatures and it will be necessary to keep the machine in a heated facility. More warm up time is also necessary after starting.

CLICK HERE TO **DOWNLOAD** THE COMPLETE MANUAL

- Thank you very much for reading the preview of the manual.
- You can download the complete manual from: www.heydownloads.com by clicking the link below



- Please note: If there is no response to CLICKING the link, please download this PDF first and then click on it.

CLICK HERE TO **DOWNLOAD** THE COMPLETE MANUAL