



YAMAHA

YFM35FXG

Service Manual



CLICK HERE TO **DOWNLOAD** THE COMPLETE MANUAL

- Thank you very much for reading the preview of the manual.
- You can download the complete manual from: www.heydownloads.com by clicking the link below



- Please note: If there is no response to CLICKING the link, please download this PDF first and then click on it.

CLICK HERE TO **DOWNLOAD** THE COMPLETE MANUAL



TIGHTENING TORQUE

Parts to be tightened	Parts name	Thread size	Q'ty	Tightening torque			Remarks
				Nm	m•kg	ft•lb	
Cylinder head oil passage	Union bolt	M6	1	7	0.7	5.1	
Cylinder head (exhaust pipe)	Stud bolt	M6	2	7	0.7	5.1	
Cylinder head	Bolt	M10	4	40	4.0	29	
	Bolt	M8	2	20	2.0	14	
Breather plate	Bolt	M6	2	10	1.0	7.2	
Bearing retainer (camshaft)	Bolt	M6	2	8	0.8	5.8	Use lockwasher
Spark plug	—	M12	1	18	1.8	13	
Cylinder	Bolt	M6	1	10	1.0	7.2	
CDI magneto	Bolt	M10	1	50	5.0	36	
Balancer driven gear	Nut	M16	1	60	6.0	43	Use lockwasher
Valve adjusting screw	Nut	M7	2	20	2.0	14	
Cam sprocket	Bolt	M10	1	60	6.0	43	
Cam chain tensioner cap	Plug	M11	1	23	2.3	17	
Cam chain tensioner	Bolt	M6	2	10	1.0	7.2	
Cam chain guide	Bolt	M6	2	10	1.0	7.2	
Oil pump assembly	Screw	M6	1	7	0.7	5.1	
Oil pump	Screw	M6	3	7.5	0.75	5.4	
Oil drain plug	Plug	M35	1	32	3.2	23	
Oil filter cover joint pipe	Joint	M14	2	50	5.0	36	
Oil delivery pipe (crankcase cover)	Union bolt	M8	2	18	1.8	13	
Oil cooler hose	Nut	—	4	35	3.5	25	
Oil cooler	Bolt	M6	2	7	0.7	5.1	
Oil delivery pipe (crankcase)	Union bolt	M8	2	16	1.6	11	
Carburetor joint	Bolt	M8	2	20	2.0	14	
Carburetor	Screw	M4	2	2	0.2	1.4	
Air filter	Bolt	M6	3	7	0.7	5.1	
Muffler and exhaust pipe	Bolt	M8	1	20	2.0	14	
Muffler and pipe	Bolt	M6	1	8	0.8	5.8	
Exhaust pipe protector	Bolt	M6	3	11	1.1	8.0	
Exhaust pipe	Nut	M6	2	12	1.2	8.7	
Muffler	Bolt	M8	2	27	2.7	19	
Bearing retainer (crankcase)	Screw	M6	4	8	0.8	5.8	
Crankcase cover (left)	Bolt	M5	3	7	0.7	5.1	
Bearing retainer (crankcase cover)	Torx screw	M6	3	10	1.0	7.2	
Crankcase	Bolt	M8	3	26	2.6	19	
Starter one way clutch (for USA)	Bolt	M8	3	30	3.0	22	
(except for USA)	Bolt	M8	6	30	3.0	22	
Clutch carrier	Nut	M22	1	140	14	100	Stake
Pressure plate	Screw	M6	5	8	0.8	5.8	
Clutch boss	Nut	M16	1	90	9.0	65	Use lockwasher
Bearing retainer (middle drive axle)	Torx screw	M8	4	25	2.5	18	
Middle drive axle	Nut	M22	1	130	13	94	Stake
Bearing housing	Bolt	M8	6	32	3.2	23	
Bearing housing	Nut	M65	1	110	11	80	
Driven pinion	Nut	M14	1	97	9.7	70	
Driven pinion	Bolt	M8	4	25	2.5	18	
Universal joint	Nut	M14	1	97	9.7	70	
Crankcase (left)	Nut	M55	1	80	8.0	58	
Shift cam side plate	Torx screw	M6	1	12	1.2	8.7	
Shift cam segment	Torx screw	M6	1	12	1.2	8.7	
Stopper lever	Bolt	M6	1	10	1.0	7.2	

YAMAHA MOTOR CO.,LTD.

PRINTED IN U.

PISTON RING	4-33
PISTON PIN	4-34
CRANKSHAFT	4-35
BALANCER DRIVE GEAR AND DRIVEN GEAR	4-36
PRIMARY GEARS	4-36
PRIMARY CLUTCH	4-36
SECONDARY CLUTCH	4-37
OIL PUMP	4-39
SHIFTER AND TRANSMISSION	4-40
STARTER DRIVES	4-42
STARTER PULLEY AND RECOIL STARTER (EXCEPT FOR USA)	4-43
OIL STRAINER, OIL FILTER AND OIL PIPES	4-43
CRANKCASE	4-44
BEARINGS AND OIL SEALS	4-44
CIRCLIPS AND WASHERS	4-44
MIDDLE GEAR SERVICE	4-45
REMOVAL	4-46
DISASSEMBLY	4-46
INSPECTION	4-49
MIDDLE DRIVE AND DRIVEN GEAR SHIM SELECTION	4-50
ASSEMBLY	4-53
INSTALLATION	4-57
GEAR LASH MEASUREMENT	4-58
ENGINE ASSEMBLY AND ADJUSTMENT	4-59
OIL PUMP	4-59
VALVE, CAM SHAFT AND ROCKER ARM	4-61
CRANKSHAFT	4-64
TRANSMISSION	4-64
CRANKCASE ASSEMBLY	4-65
OIL PUMP AND BALANCER DRIVE GEARS	4-66
REVERSE SHIFT BRACKET	4-69
CLUTCH	4-71
CDI ROTOR AND CAM CHAIN	4-73
SHIFT SHAFT AND STARTER IDLE GEAR	4-75
CRANKCASE COVER (LEFT)	4-77
PISTON	4-79
CYLINDER HEAD AND CYLINDER	4-81
STARTER MOTOR	4-86
RECOIL STARTER (EXCEPT FOR USA)	4-87
REMOUNTING ENGINE	4-89

SPECIAL TOOLS



17
Gear lash measurement tool
P/N. YM-01231
P/N. 90890-01231

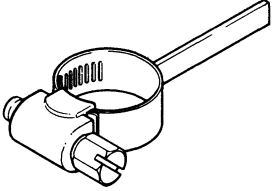

This tool is used to measure the gear lash.

18
Dial gauge
P/N. YM-03097
P/N.90890-03097

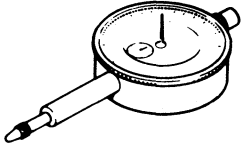

This tool is used to measure the gear lash for the middle gear and final gear.

19-A
Crankshaft installer set
P/N. YU-90050

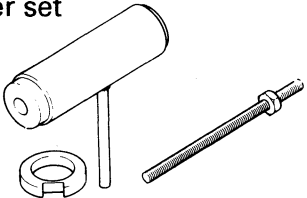

These tools are used to install the crankshaft, buffer boss and oil pump drive gear.

19-B
Buffer boss installer set
P/N. 90890-04088

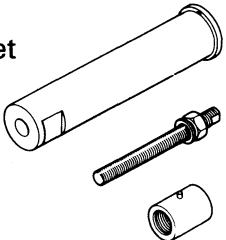

These tools are used to install the crankshaft, buffer boss and oil pump drive gear.

20
Crank pot spacer
P/N. YM-91044
P/N. 90890-04081

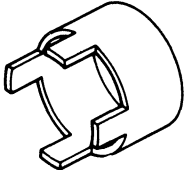

This tool is used to install the crankshaft.

21-A
Pot extension
P/N. YM-33280

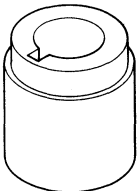

This tool is used to install the crankshaft.

21-B
Spacer
P/N. 90890-01016



This tool is used to install the crankshaft.

22
Sealant (Quick Gasket®)
P/N. ACC-11001-15-01
YAMAHA bond No. 1215
P/N. 90890-85505

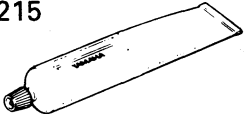

This sealant (bond) is used for crankcase mating surface, etc.

23
Pot spacer
P/N. YM-90070-A



This tool is used to install the oil pump drive gear, and install the buffer boss.

24
Adapter #11
P/N. YM-33279

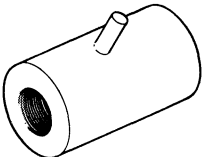

This tool is used to install the buffer boss.

MAINTENANCE SPECIFICATIONS

SPEC



Model	YFM35FXG
Clutch: Friction plate thickness Quantity Friction plate wear limit Clutch plate thickness Quantity Warp limit Clutch plate thickness Quantity Clutch spring free length Quantity Minimum length Clutch release method Automatic centrifugal clutch Clutch shoe thickness <Wear limit> Clutch shoe spring free length Clutch-in revolution Clutch-stall revolution	2.94 ~ 3.06 mm (0.116 ~ 0.120 in) 7 2.8 mm (0.11 in) 1.5 ~ 1.7 mm (0.059 ~ 0.067 in) 4 0.2 mm (0.008 in) 1.9 ~ 2.1 mm (0.075 ~ 0.083 in) 2 40.1 mm (1.58 in) 5 39 mm (1.54 in) Inner push, cam push 2 mm (0.08 in) <1.5 mm (0.06 in)> 42.5 mm (1.67 in) 1,800 ~ 2,000 r/min 2,950 ~ 3,300 r/min
Transmission: Main axle deflection limit Drive axle deflection limit	0.08 mm (0.003 in) 0.08 mm (0.003 in)
Shifter: Shifter type	Cam drum and guide bar
Air filter oil grade:	Foam-air-filter oil or SAE10W30 type SE motor oil
Carburetor: I. D. mark Main jet (M.J) Main air jet (M.A.J) Jet needle (J.N) Needle jet (N.J) Pilot air jet (P.A.J.1) Pilot air jet (P.A.J.2) Pilot outlet (P.O) Pilot jet (P.J) Bypass 1 (B.P.1) Bypass 2 (B.P.2) Bypass 3 (B.P.3) Pilot screw (P.S) Valve seat size (V.S) Starter jet (G.S.1) Throttle valve size (Th.V) Float height (F.H) Fuel level (F.L)	4KB 01 #135 0.6 5HL43-3 O-6 (#765) 0.9 1.0 0.8 #40 0.8 0.8 0.8 2 turns out 2.5 #62.5 #125 11.4 ~ 13.4 mm (0.45 ~ 0.53. in) 2.0 ~ 3.0 mm (0.08 ~ 0.12 in) Above the float chamber mating surface 1,450 ~ 1,550 r/min 36.0 kPa (270 mmHg, 10.6 inHg)
Engine idle speed Intake vacuum	1,450 ~ 1,550 r/min 36.0 kPa (270 mmHg, 10.6 inHg)



EXCLUSIVE SPECIFICATIONS

The following specifications are exclusive for the below listed countries.

For specifications other than below, please refer to the General and maintenance specifications.

For Canada

Model code	4KB2																								
Engine start number	4KB-022101																								
Vehicle identification number	JY44KBN0*SA022101																								
Starting system	Electric and recoil starter																								
Fuel: Type	Regular unleaded gasoline																								
Spark plug: Type Manufacturer	DR8EA NGK																								
C.D.I.: Magneto model/manufacture Pickup coil resistance/color	F004T42371/MITSUBISHI 459 ~ 561 Ω at 20°C (68°F)/(White/Red-White/ Green)																								
C.D.I. unit model/manufacture	F008T32371/MITSUBISHI																								
Charging system: Model/manufacture Standard output	F004T42371/MITSUBISHI 14V 12A at 3,000 r/min																								
<table border="1"> <caption>Charging Current vs Engine Speed</caption> <thead> <tr> <th>Engine speed (x 10³ r/min)</th> <th>Charging current (A)</th> </tr> </thead> <tbody> <tr><td>0</td><td>0</td></tr> <tr><td>1</td><td>10</td></tr> <tr><td>2</td><td>13</td></tr> <tr><td>3</td><td>14.5</td></tr> <tr><td>4</td><td>15.5</td></tr> <tr><td>5</td><td>16</td></tr> <tr><td>6</td><td>16</td></tr> <tr><td>7</td><td>16</td></tr> <tr><td>8</td><td>16</td></tr> <tr><td>9</td><td>16</td></tr> <tr><td>10</td><td>16</td></tr> </tbody> </table>		Engine speed (x 10 ³ r/min)	Charging current (A)	0	0	1	10	2	13	3	14.5	4	15.5	5	16	6	16	7	16	8	16	9	16	10	16
Engine speed (x 10 ³ r/min)	Charging current (A)																								
0	0																								
1	10																								
2	13																								
3	14.5																								
4	15.5																								
5	16																								
6	16																								
7	16																								
8	16																								
9	16																								
10	16																								
Stator coil resistance/color	0.70 ~ 0.86 Ω at 20°C (68°F)/(White-White)																								



- ① Headlights
- ② Breather hose (front axle gear case)
- ③ Breather hose (rear gear housing)
- ④ Battery
- ⑤ Battery negative lead
- ⑥ Battery positive lead
- ⑦ Wireharness
- ⑧ Starter motor lead
- ⑨ Crankcase breather hose

- A Clamp the wireharness at the point where the white tape is affixed to it.
- B Pass the breather hose through the wire guide.
- C Pass the breather hose through the guide hole in the frame bracket and pass it above the damper plate.
- D Pass the reverse control cable, the parking brace cable, the breather hose and the rear brake cable through the wire guide. Position these cables in the above order from inside to outside.
- E Pass the wireharness and the breather hose above the carburetor joint.
- F Pass the battery leads in front of the rear fender's rim and then pass them through the guide hole in the rear fender.

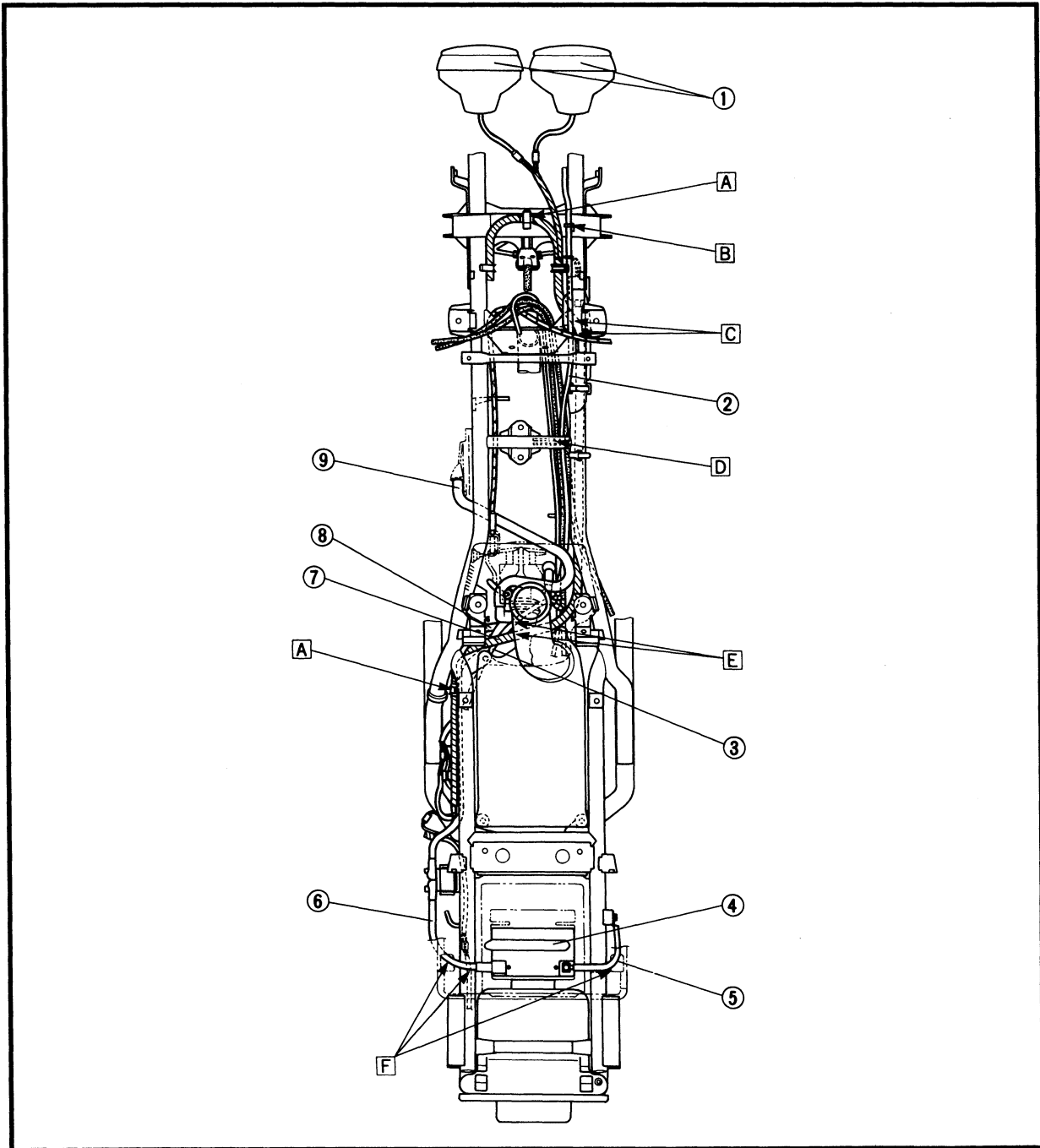

IDLING SPEED ADJUSTMENT

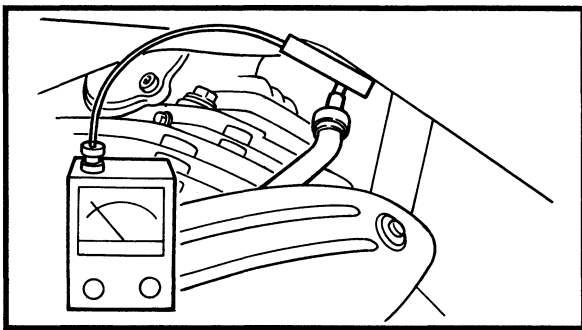

IDLING SPEED ADJUSTMENT

1. Start the engine and let it warm up for several minutes.
2. Attach:
 - Inductive tachometer (to the spark plug lead)

	Inductive tachometer: P/N. YU-08036-A, 90890-03113
--	--

3. Check:
 - Engine idling speed
Out of specification → Adjust.

	Engine idling speed: 1,450 ~ 1,550 r/min
--	--

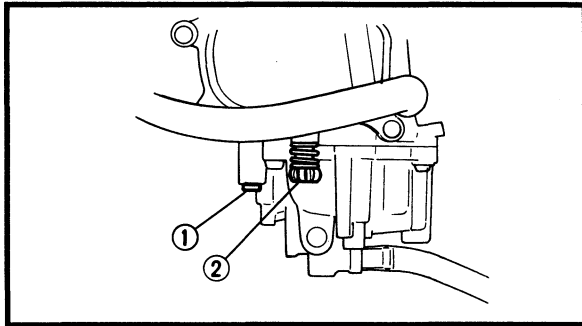

4. Adjust:
 - Engine idling speed

Adjustment steps:

- Turn in the pilot screw ① until it is lightly seated.
- Turn out the pilot screw for the specified number of turns.

Pilot screw: 2 turns out

- Turn the throttle stop screw ② in or out until specified idling speed is obtained.

Turn in → Idling speed becomes higher.
Turn out → Idling speed becomes lower.

5. Detach
 - Inductive tachometer

6. Adjust:
 - Throttle cable free play
Refer to the "THROTTLE CABLE FREE PLAY ADJUSTMENT" section.

	Free play: 3 ~ 5 mm (0.12 ~ 0.20 in)
--	--

ENGINE OIL REPLACEMENT

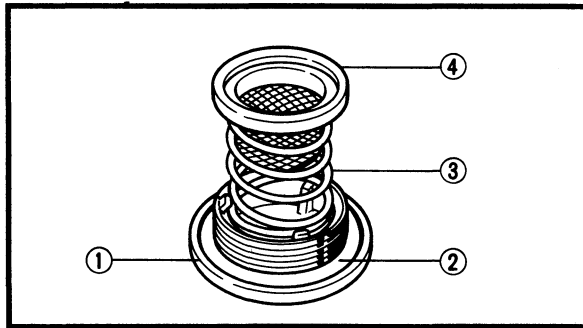
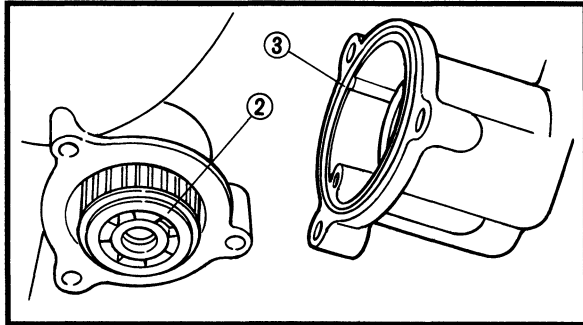
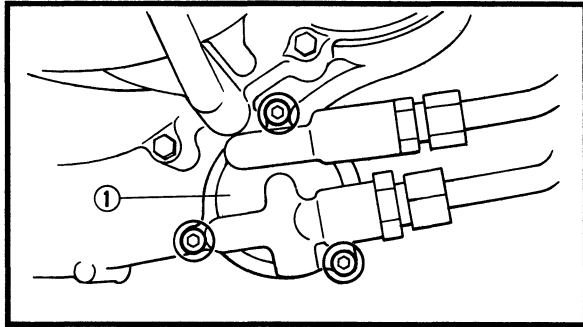

4. If the oil filter is to be replaced during this oil change, remove the following parts and reinstall them.

Replacement steps:

- Remove the oil filter cover ① and oil filter element ②.
- Check the O-ring ③, if cracked or damaged, replace them with a new one.
- Install the oil filter element and oil filter cover.



Bolt (oil filter cover):
8 Nm (0.8 m · kg, 5.8 ft · lb)

5. Install:

- Drain plug

CAUTION

Before reinstalling the drain plug ①, do not forget to fit the O-ring ②, compression spring ③ and oil strainer ④.



Drain plug:
32 Nm (3.2 m · kg, 23 ft · lb)

6. Fill:

- Crankcase

Refer to the "ENGINE OIL LEVEL INSPECTION" section.



Oil quantity:

Total amount:

3.5 L (3.1 Imp qt, 3.7 US qt)

Periodic oil change:

2.9 L (2.6 Imp qt, 3.1 US qt)

With oil filter replacement:

3.0 L (2.6 Imp qt, 3.2 US qt)

7. Install:

- Dipstick

8. Warm up the engine for a few minutes, then stop the engine.

AIR BLEEDING (HYDRAULIC BRAKE SYSTEM)

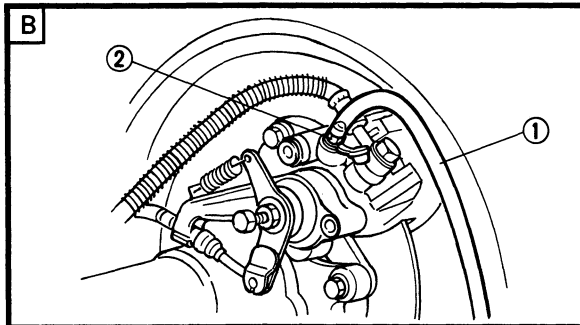
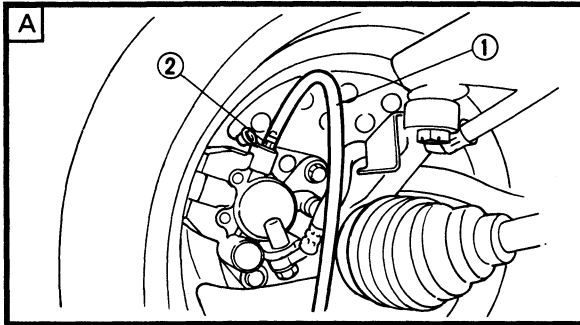

1. Bleed:

- Brake system

Air bleeding steps:

- Add proper brake fluid to the reservoir.
- Install the diaphragm. Be careful not to spill any fluid or allow the reservoir to overflow.
- Connect the clear plastic hose ① tightly to the caliper bleed screw ②.

Ⓐ Front

Ⓑ Rear

- Place the other end of the hose into a container.
- Slowly apply the brake lever or pedal several times.
- Pull the lever in or push down on the pedal. Hold the lever or pedal in position.
- Loosen the bleed screw and allow the lever or pedal to travel towards its limit.
- Tighten the bleed screw when the lever or pedal limit has been reached, then release the lever or pedal.
- Repeat steps (e) to (h) until all air bubbles have disappeared from the fluid.
- Tighten the bleed screw.



Bleed screw:

6 Nm (0.6 m • kg, 4.3 ft • lb)

NOTE:

If bleeding is difficult, it may be necessary to let the brake fluid settle for a few hours. Repeat the bleeding procedure when the tiny bubbles in the system have disappeared.

- Add brake fluid to proper level.

Refer to the "BRAKE FLUID INSPECTION" section.

⚠ WARNING

Check the operation of the brake after bleeding the brake system.

• **MAXIMUM LOADING LIMIT**

1) Vehicle load limits: 180 kg (397 lb)*

* Total weight of cargo, trailer hitch vertical load, rider, and accessories.

2) Storage box: 2 kg (4.4 lb)

3) Trailer hitch:

Horizontal load: 330 kg (728 lb)

Total weight of trailer and cargo.

Vertical load: 15 kg (33 lb)

Vertical weight on trailer hitch joint.

Be extra careful of the machine balance and stability when towing a trailer.

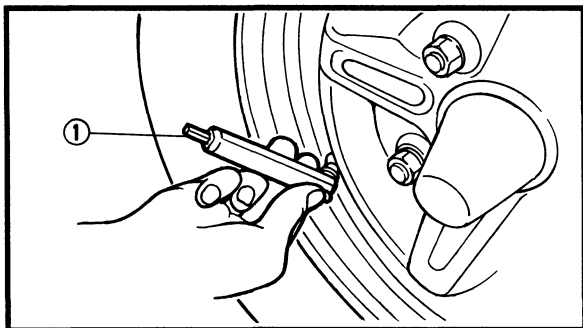

1. Measure:

- Tire pressure (cold tire pressure)
Out of specification → Adjust.

NOTE:

- The low-pressure tire gauge ① is included in the standard equipment.
- If dust or the like is stuck to this gauge, it does not provide correct readings. Therefore, make two measurements on the tire pressure and get the second reading.

Cold tire pressure	Front	Rear
Standard	25 kPa (0.25 kg/cm ² , 3.6 psi)	25 kPa (0.25 kg/cm ² , 3.6 psi)
Minimum	22 kPa (0.22 kg/cm ² , 3.2 psi)	22 kPa (0.22 kg/cm ² , 3.2 psi)
Maximum	28 kPa (0.28 kg/cm ² , 4.0 psi)	28 kPa (0.28 kg/cm ² , 4.0 psi)

⚠ WARNING

Uneven or improper tire pressure may adversely affect the handling of this machine and may cause loss of control.

- Maintain proper tire pressures.
- Set tire pressures when the tires are cold.
- Tire pressures must be equal in both front tires and equal in both rear tires.

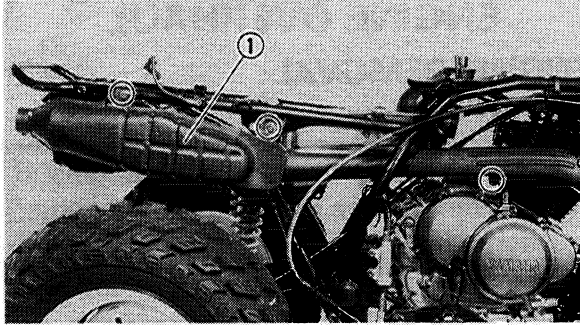
**EXHAUST PIPE AND MUFFLER**

1. Remove:

- Muffler ①
- Exhaust pipe ②

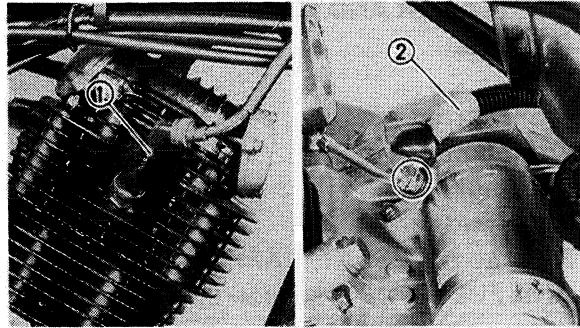
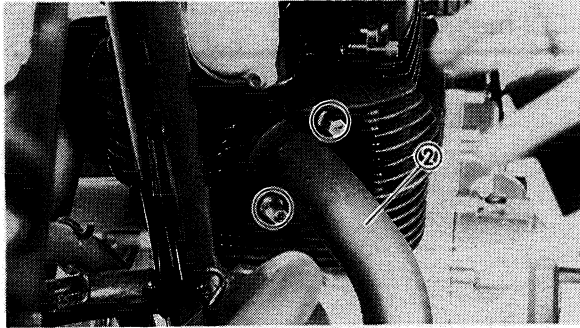
**HOSE AND LEAD**

1. Disconnect:

- Spark plug lead ①
- Starter motor lead ②

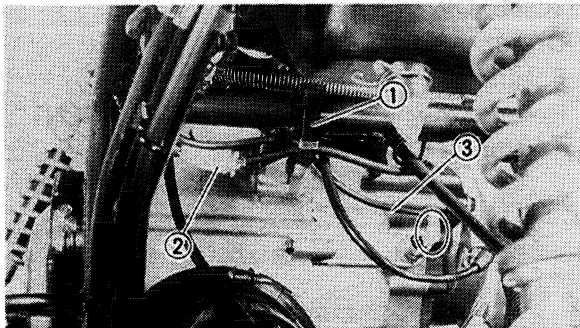

2. Remove:

- Band ①

3. Disconnect:

- Gear position switch coupler ②
- Thermo switch lead ③

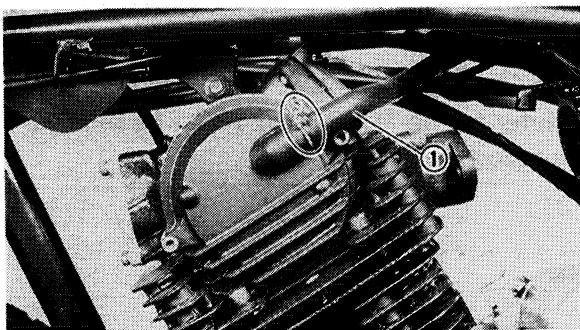

4. Disconnect:

- Breather hose (cylinder head) ①

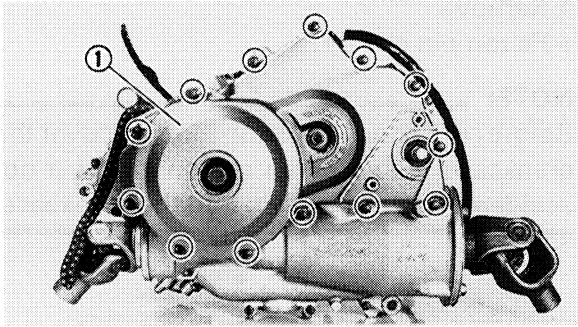

- 2.Remove:
- Crankcase cover (left) ①
 - Gasket
 - Dowel pins

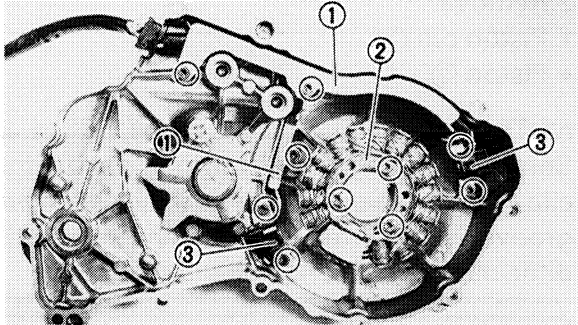

- 3.Remove:
- Lead holder ①
 - Stator assembly ②
 - Pickup coil assembly ③

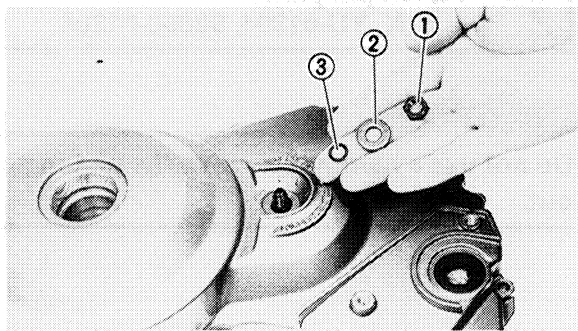

- 4.Remove:
- Locknut ①
 - Washer ②
 - O-ring ③

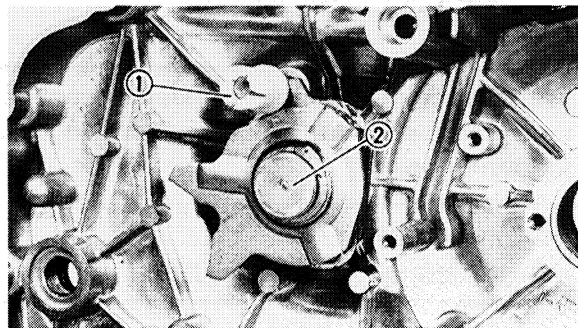

- 5.Remove:
- Stopper collar ①
 - Shift guide assembly ②

NOTE: _____
 When removing the left crankcase cover, the stopper collar ① can easily fall off. Make sure that you do not lose this part.

SHIFT SHAFT AND STARTER IDLE GEAR

NOTE: _____
 With the engine mounted, the shift shaft and starter idle gear can be maintained by removing the following parts.

- Shift pedal
- Footrest (left)
- Crankcase cover (left)

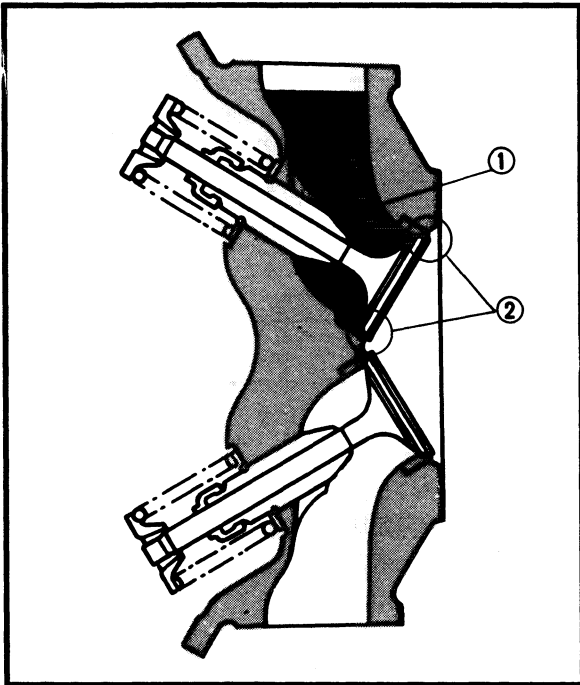

5. Check:

- Valve sealing
Leakage at valve seat → Inspect the valve face, valve seat and valve seat width.
Refer to the "INSPECTION AND REPAIR – VALVE SEAT" section.

NOTE:

Before removing the internal parts (valve, valve spring, spring seat, etc.) of the cylinder head, the valve sealing should be checked.

Checking steps:

- Supply a clean solvent ① into the intake and exhaust ports.
- Check the valve sealing. There should be no leakage at the valve seats ②.

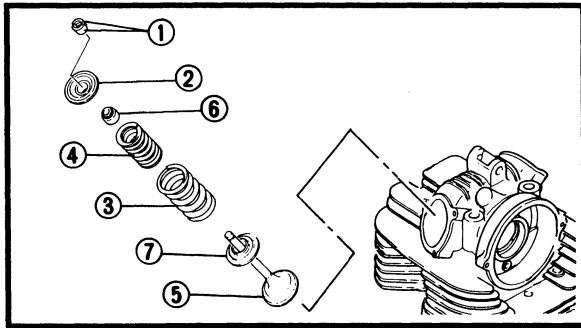

6. Remove:

- Valve cotter ①
- Spring retainer ②
- Valve spring (outer) ③
- Valve spring (inner) ④
- Valve ⑤
- Oil seal ⑥
- Spring seat ⑦

NOTE:

Compress the valve spring to remove the valve cotteners by the valve spring compressor ⑧.

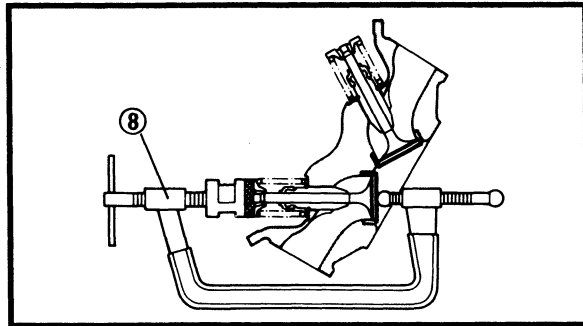

Valve spring compressor:
P/N. YM-04019, 90890-04019

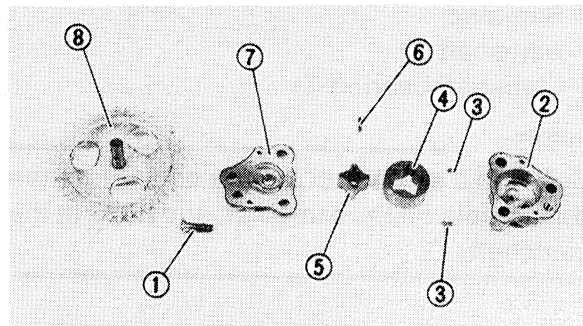

OIL PUMP

1. Remove:

- Screw ①
- Pump housing ②
- Dowel pins ③
- Outer rotor ④
- Inner rotor ⑤
- Pin ⑥
- Pump cover ⑦
- Pump shaft ⑧

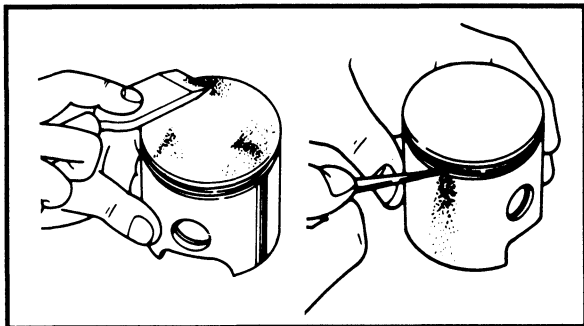

2. Eliminate:
- Carbon deposits
(from the piston crown and ring grooves)

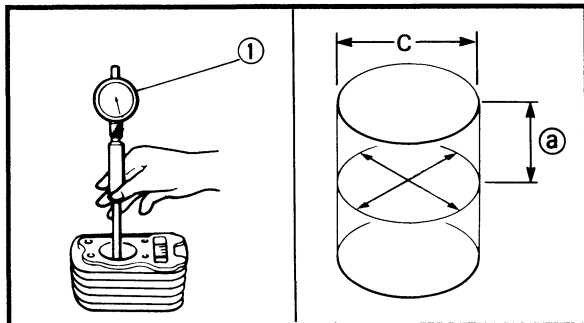

3. Measure:
- Piston-to-cylinder clearance

Measurement steps:

First steps

- Measure the cylinder bore "C" with a cylinder bore gauge ①.
- ① 40 mm (1.57 in) from the cylinder top

NOTE:

Measure the cylinder bore "C" in parallel to and at right angles to the cylinder matching surface.

Then, find the average of the measurements.

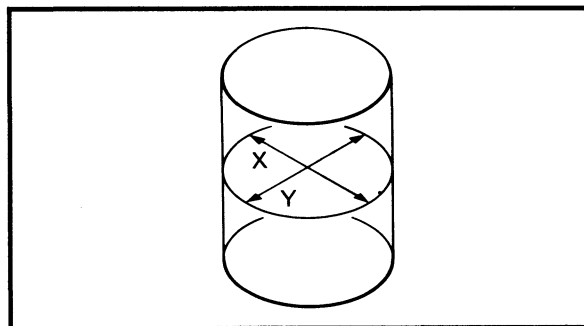



	Standard	Wear limit
Cylinder bore "C"	82.97 ~ 83.02 mm (3.267 ~ 3.269 in)	83.15 mm (3.2736 in)
$C = \frac{X+Y}{2}$		

- If out of specification, rebore or replace the cylinder, and the piston and piston rings as a set.

2nd steps

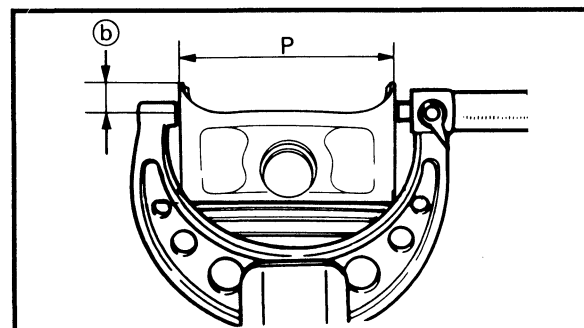
- Measure the piston skirt diameter "P" with a micrometer.
- ② 5.5 mm (0.22 in) from the piston bottom edge



	Piston skirt diameter "P"	
Standard	82.92 ~ 92.97 mm (3.265 ~ 3.267 in)	

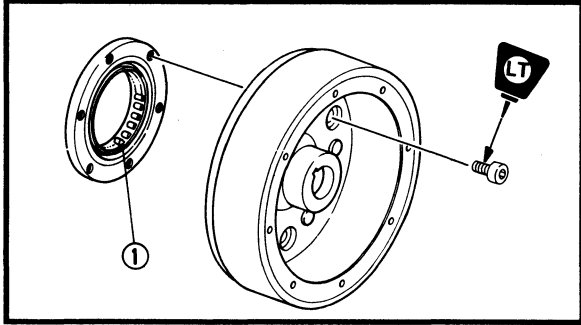

STARTER DRIVES

1. Inspect:

- Starter one-way ①
Cracks/Damage → Replace.

NOTE:

The arrow mark on the starter clutch must face inward, away from the CDI rotor.

	<p>Bolts (starter clutch): 30 Nm (3.0 m · kg, 22 ft · lb) LOCTITE®</p>
---	---

Starter clutch operation

- Install the starter wheel gear to the starter clutch, and hold the starter clutch.
- When turning the starter wheel gear counter clockwise **A**, the starter clutch and the wheel gear should be engaged.
If not, the starter clutch is faulty. Replace it.
- When turning the starter wheel gear clockwise **B**, the starter wheel gear should turn freely.
If not, the starter clutch is faulty. Replace it.

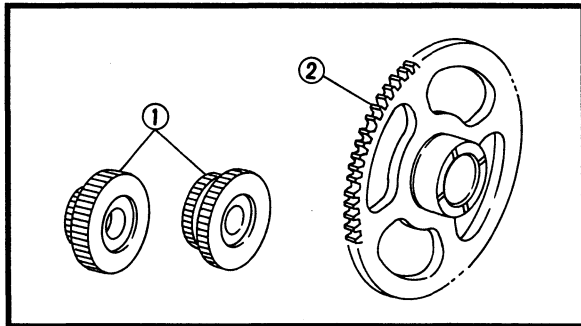
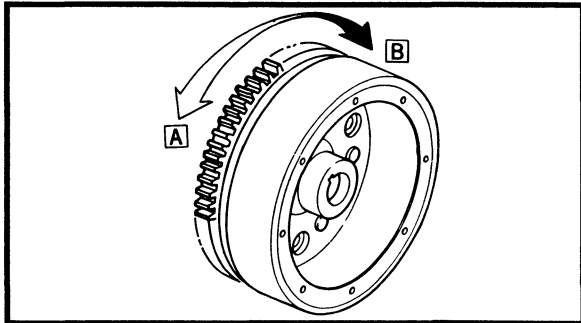

2. Inspect:

- Starter idle gear teeth ①
- Starter wheel gear teeth ②
Burrs/Clips/Roughness/Wear → Replace.

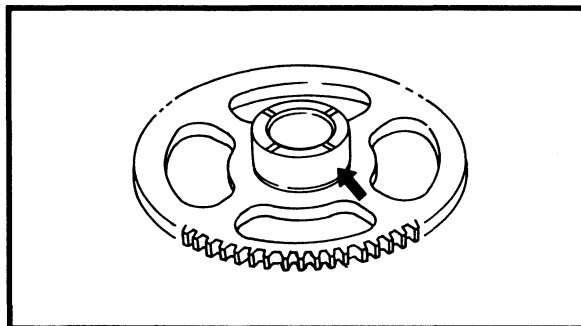

3. Inspect:

- Starter wheel gear (contacting surface)
Pitting/Wear/Damage → Replace.



Shim sizes are supplied in the following thickness.

 Middle drive pinion gear shim		
Thickness (mm)	0.10	0.40
	0.15	0.50
	0.20	0.60
	0.30	

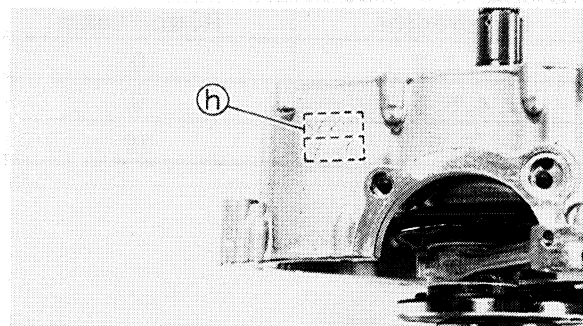
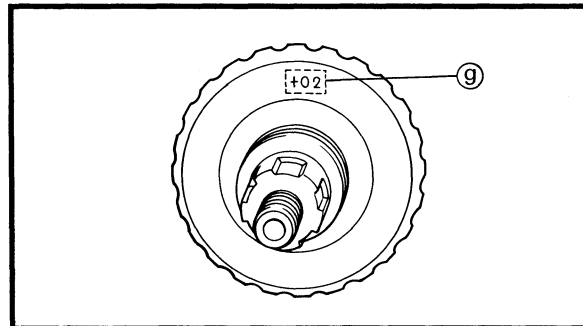
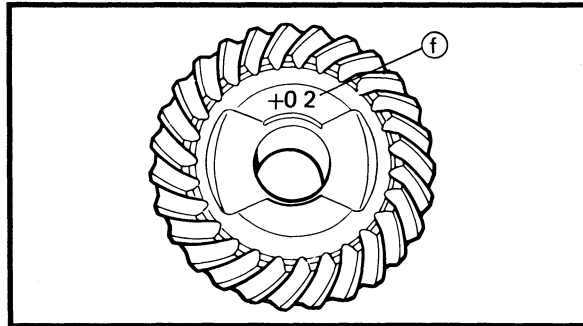
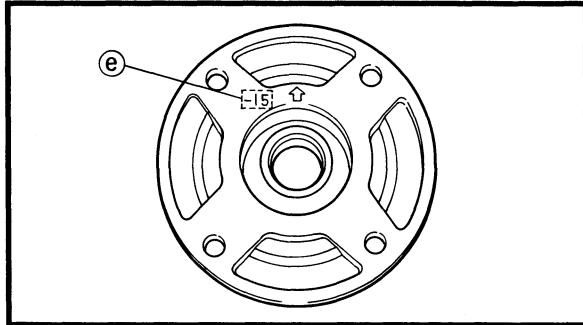

- To find shim thickness "B" use following formula:

<p>Middle driven pinion gear shim thickness: "B" = e - f + g - h - i - 0.05</p>
--

Where:

- ⓔ = a numeral (usually a decimal number) on the bearing housing is either added to or subtracted from "76".
- ⓕ = a numeral (usually a decimal number) on the driven pinion gear is either added to or subtracted from "59".
- ⓖ = a numeral (usually a decimal number) on the driven pinion gear is either added to or subtracted from "79.5".
- ⓓ = a numeral (usually a decimal number) on the right crankcase specifies a thickness of "56.5".
- ⓔ = a numeral (usually a decimal number) on the left crankcase specifies a thickness of "39.5".

Example:

- 1) If the bearing housing is marked "-15"
.....ⓔ is 75.85
- 2) If the driven pinion gear is marked "+02"
.....ⓕ is 59.02
- 3) If the driven pinion gear is marked "+02"
.....ⓖ is 79.52
- 4) If the crankcase (right) is marked "56.49"
.....ⓓ is 56.49
- 5) If the crankcase (left) is marked "39.49"
.....ⓔ is 39.49

$$B = 75.85 - 59.02 + 79.52 - 56.49 - 39.49 - 0.05 = 0.32$$

RIGHT CRANKCASE

- | | | |
|------------------------|------------------------|-------------------|
| ① Middle drive gear | ⑨ Middle driven gear | ⑰ Crankshaft |
| ② 1st wheel gear | ⑩ Middle drive shaft | ⑱ Balancer weight |
| ③ Drive axle | ⑪ Main axle | |
| ④ 5th wheel gear | ⑫ 5th pinion gear | |
| ⑤ 3rd wheel gear | ⑬ 3rd pinion gear | |
| ⑥ 4th wheel gear | ⑭ 4th pinion gear | |
| ⑦ Reverse wheel gear 1 | ⑮ 2nd pinion gear | |
| ⑧ 2nd wheel gear | ⑯ Reverse wheel gear 2 | |

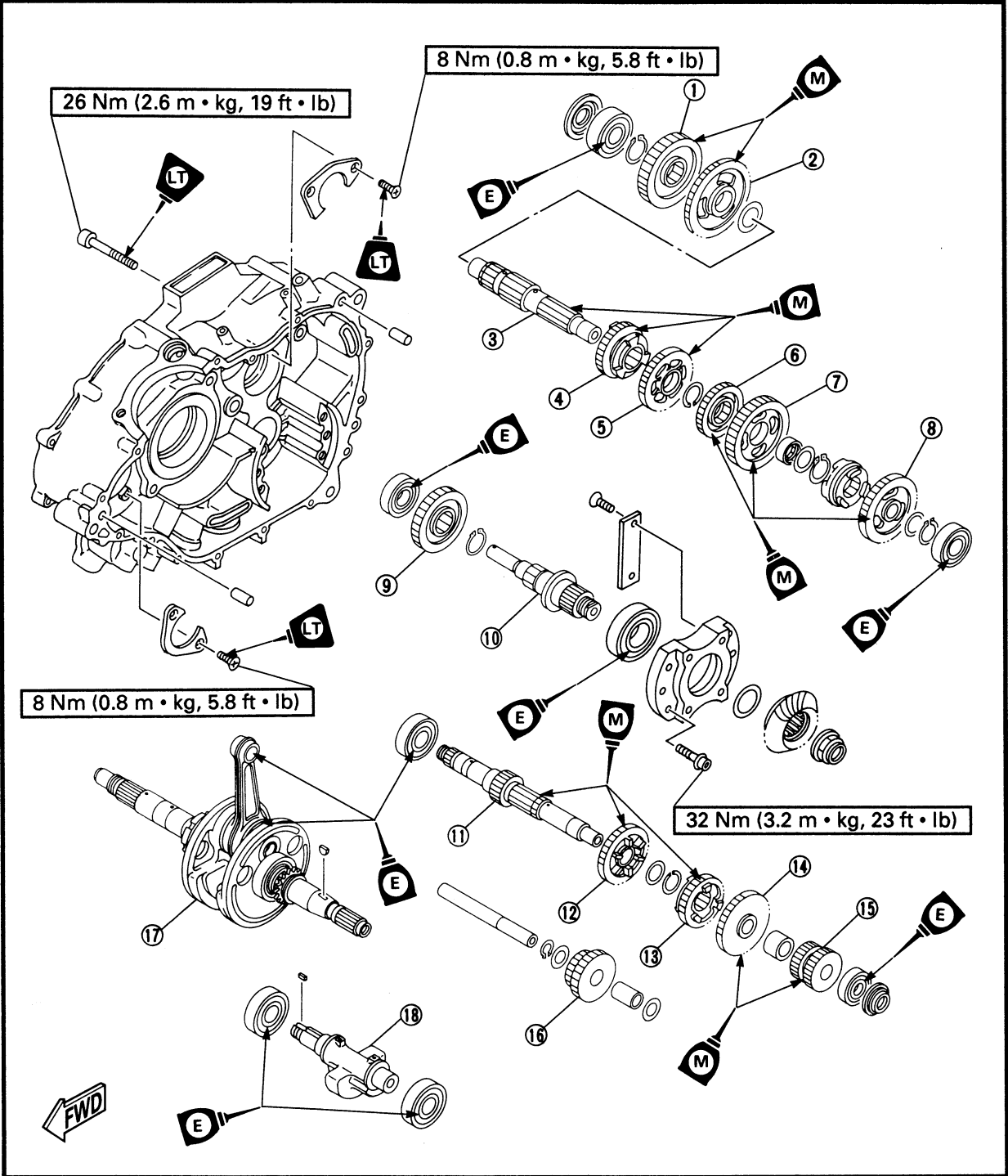

CLICK HERE TO **DOWNLOAD** THE COMPLETE MANUAL

- Thank you very much for reading the preview of the manual.
- You can download the complete manual from: www.heydownloads.com by clicking the link below



- Please note: If there is no response to CLICKING the link, please download this PDF first and then click on it.

CLICK HERE TO **DOWNLOAD** THE COMPLETE MANUAL

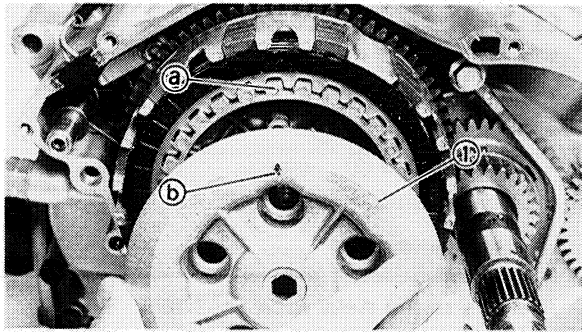

6. Install:

- Pressure plate ①
- Clutch springs
- Bolts (pressure plate)

NOTE:

- Align the punched mark ① on the clutch boss with the arrow mark ② on the pressure plate.
- Tighten the bolts (pressure plate) in stage, using a crisscross pattern.



Bolt (pressure plate):
8 Nm (0.8 m · kg, 5.8 ft · lb)

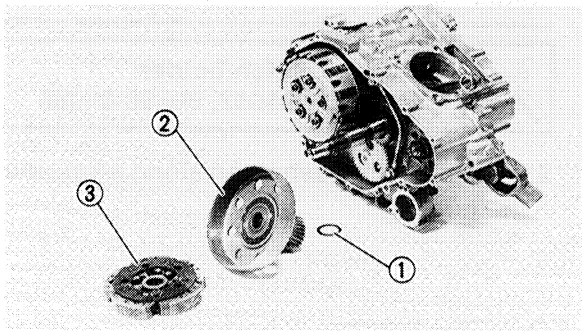

7. Install:

- Plain washer ①
- Clutch housing ②
- Clutch carrier assembly ③

NOTE:

When installing the primary clutch housing, align the indentations in the secondary clutch housing ① and the primary gear ② with each other.

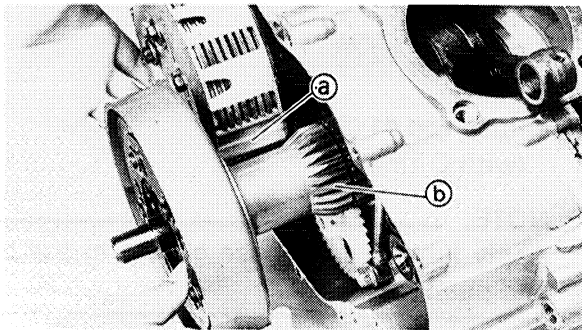

8. Install:

- Nut (primary clutch) ①

NOTE:

- Always use a new nut (primary clutch).
- Tighten the nut (primary clutch) while holding the clutch carrier assembly ② with the rotor holder ③.

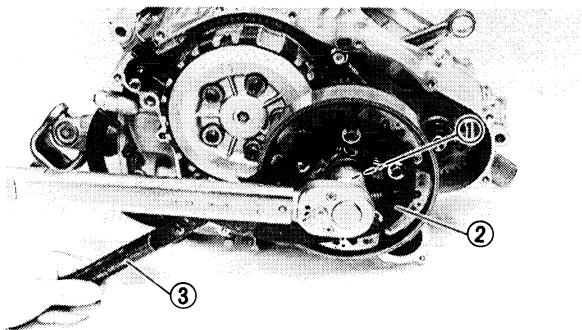

Rotor holder:
P/N. YU-01235, 90890-01235



CYLINDER HEAD

- ① Spark plug
- ② Tappet cover (intake)
- ③ Tappet cover (exhaust)
- ④ O-ring
- ⑤ Cylinder head
- ⑥ Bearing retainer
- ⑦ Lock washer
- ⑧ Gasket
- ⑨ Cam chain tensioner
- ⑩ Cam chain guide (intake)
- ⑪ Cam sprocket
- ⑫ Cam chain
- ⑬ Cam chain tensioner (exhaust)
- ⑭ Sprocket cover
- ⑮ Side cover

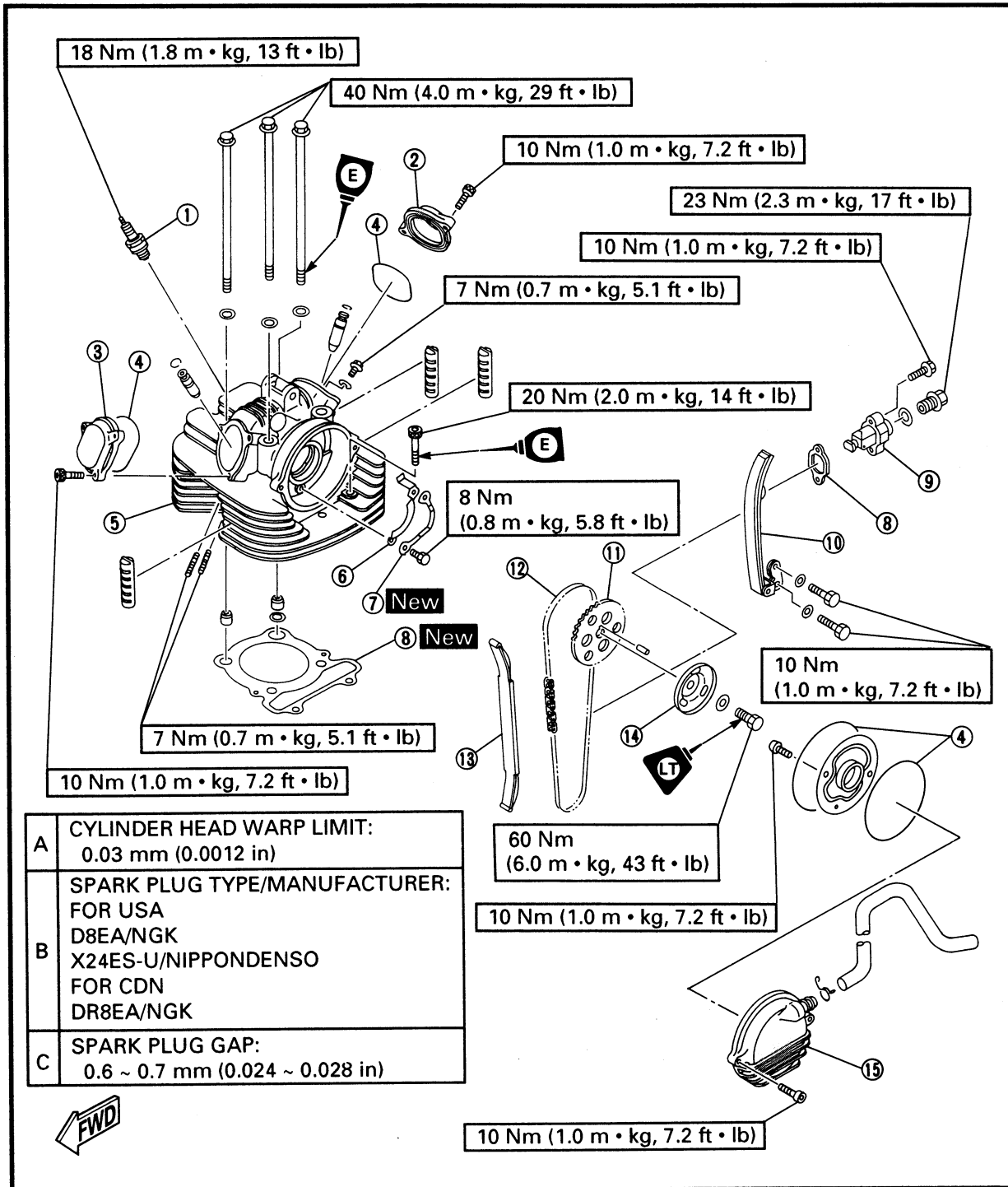

A	CYLINDER HEAD WARP LIMIT: 0.03 mm (0.0012 in)
B	SPARK PLUG TYPE/MANUFACTURER: FOR USA D8EA/NGK X24ES-U/NIPPONDENSO FOR CDN DR8EA/NGK
C	SPARK PLUG GAP: 0.6 ~ 0.7 mm (0.024 ~ 0.028 in)

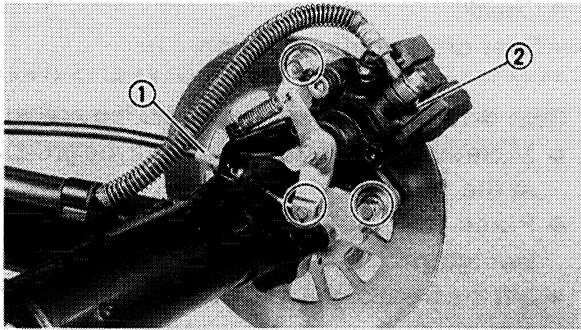

10. Connect:
- Parking brake cable ①
11. Install:
- Rear brake caliper ②
 - Rear wheels



Bolt (rear brake caliper):
 26 Nm (2.6 m · kg, 19 ft · lb)
Nut (rear wheel):
 64 Nm (6.4 m · kg, 46 ft · lb)

Refer to the "REAR WHEEL" section in CHAPTER 7.

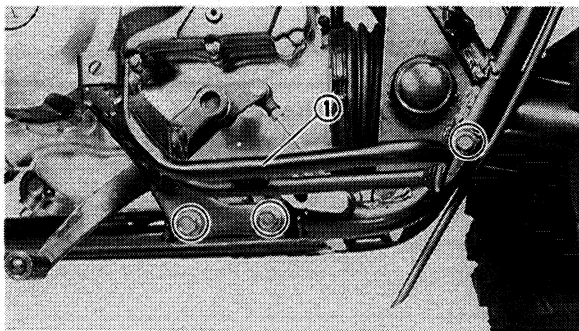

12. Install:
- Footrest (left) ①



10 mm bolt (footrest):
 64 Nm (6.4 m · kg, 46 ft · lb)

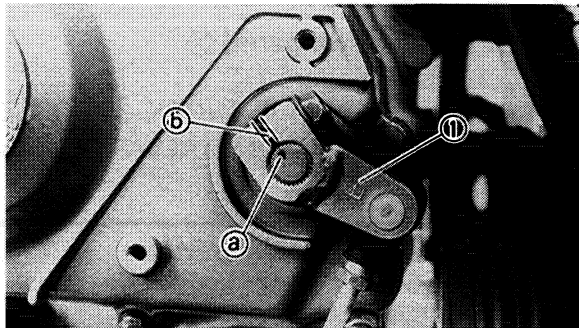

13. Install:
- Shift pedal link

NOTE: _____
 Align the mark ① on the shift shaft with the slot ② on the shift pedal link.

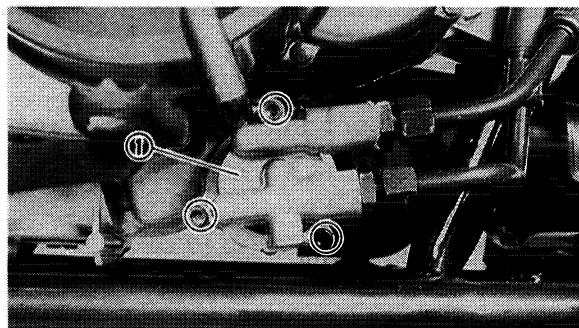

14. Install:
- Oil filter element
 - Oil filter cover ①

NOTE: _____
 Check the O-rings for damage if damaged, replace.

CARBURETOR

CARB

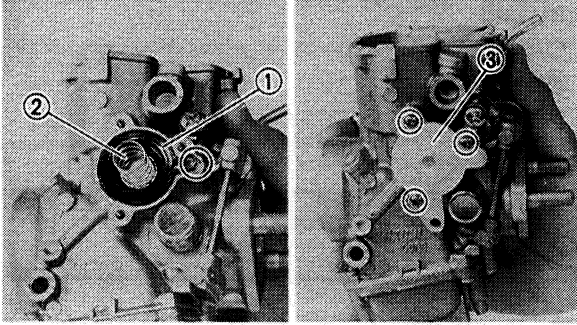

5. Install:

- Diaphragm (coasting enricher) ①
- Spring ②
- Cover ③

NOTE:

Match the tab on the rubber diaphragm to the matching recess in the carburetor body.

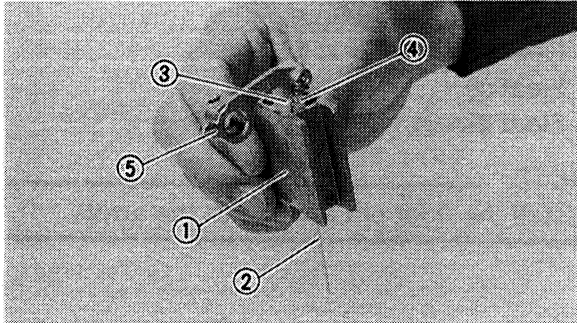

6. Install:

- Piston valve ①
- Jet needle ②
- Needle holder ③
- Spring ④
- Connecting arm ⑤

NOTE:

Install the spring ④ as shown.

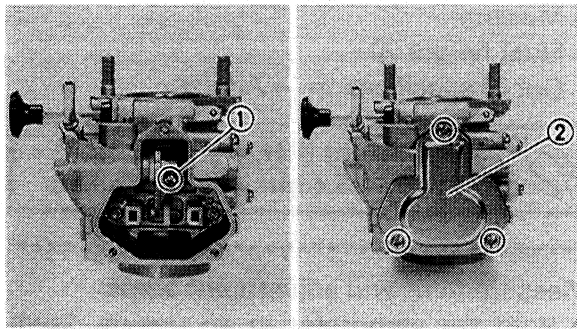

7. Install:

- Screw (connecting arm) ①
- Gasket
- Carburetor top cover ②

INSTALLATION

Reverse the "REMOVAL" procedures. Note the following points.

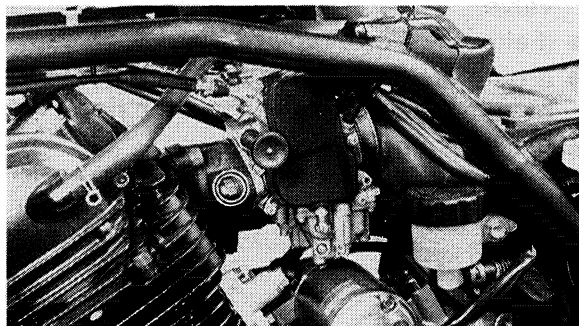

1. Install:

- Carburetor assembly



Nut (carburetor joint):
16 Nm (1.6 m • kg, 11 ft • lb)

DIFFERENTIAL GEAR AND CONSTANT VELOCITY JOINTS

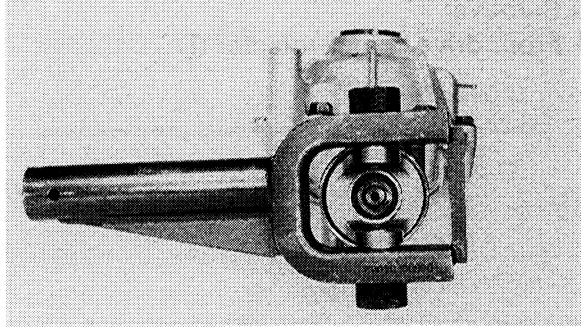

2. Attach:

- Universal joint holder
(onto the universal joint yoke)



Universal joint holder:
P/N. YM-04062, 90890-04062

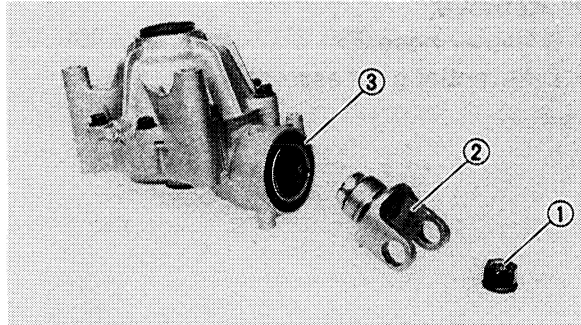

3. Remove:

- Nut ①
- Universal joint yoke ②
- Oil seal ③

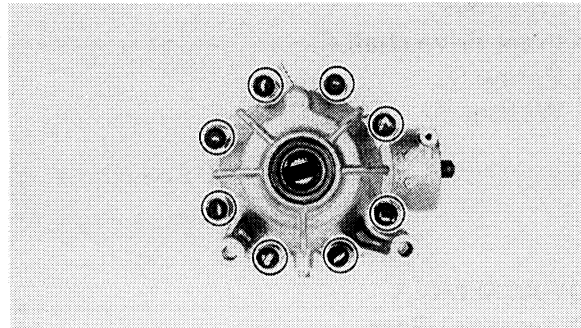

4. Remove:

- Bolts (M8)
- Bolts (M10)

NOTE:

Working in a crisscross pattern, loosen the bolt 1/4 turn each. Remove then after all loosened.

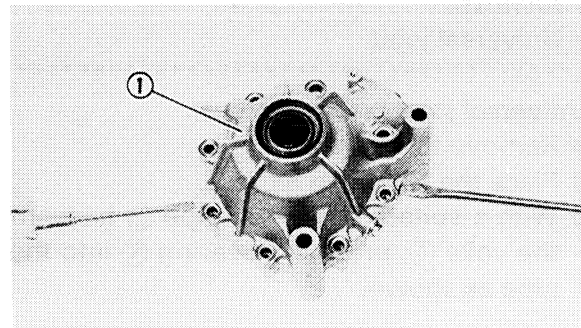

5. Remove:

- Bearing housing ①

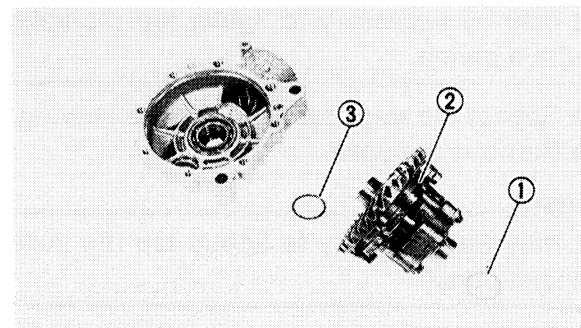

6. Remove:

- Shim(s) (left) ①
- Differential gear assembly ②
- Shim(s) (right) ③

DIFFERENTIAL GEAR AND CONSTANT VELOCITY JOINTS

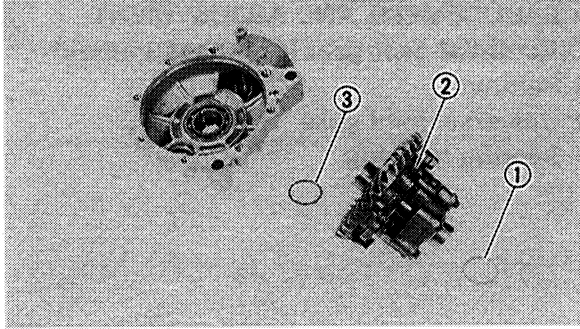

Differential Gear Gear Lash Adjustment

1. Remove:

- Shim(s) (left) ①
- Differential gear assembly ②
- Shim(s) (right) ③

2. Adjust:

- Gear lash

Gear lash adjustment steps:

- Select the suitable shim(s) by the following chart.

**Too-little gear lash →
Reduce left shim thickness.**

**Too-large gear lash →
Increase left shim thickness.**

- If increase by more than 0.05 mm(0.002 in):
Reduce right shim thickness by 0.05 mm (0.002 in) for every 0.05 mm of left shim increase.
- If reduce by more than 0.05 mm (0.002 in):
Increase right shim thickness by 0.05 mm (0.002 in) for every 0.05 mm of left shim decrease.

Ring gear shim (left and right)			
Thickness (mm)	0.50	0.90	1.30
	0.55	0.95	1.35
	0.60	1.00	1.40
	0.65	1.05	1.45
	0.70	1.10	1.50
	0.75	1.15	1.55
	0.80	1.20	1.60
	0.85	1.25	

REAR AXLE/REAR FINAL GEAR AND REAR DRIVE SHAFT

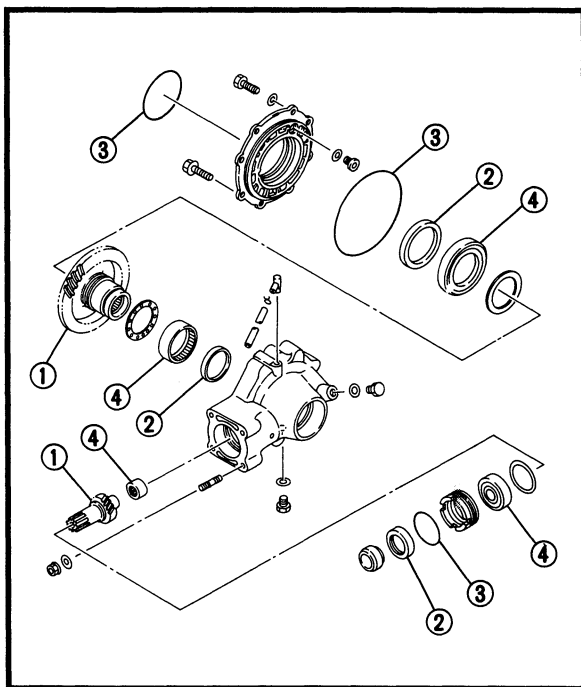

4. Inspect:

- Gear teeth ①
Pitting/Galling/Wear → Replaced drive pinion gear and ring gear as a set.
- Oil seal ②
- O-ring ③
Damage → Replace.

5. Inspect:

- Bearings ④
Damage → Replace.

NOTE:

- Reuse of roller bearing OK, but Yamaha recommends installation of new bearing. Do not reuse the oil seal.
- When the final drive pinion gear and/or ring gear are replaced, be sure to adjust the shim of the final drive pinion gear and/or ring gear, refer to the "FINAL DRIVE PINION GEAR AND RING GEAR SHIM SELECTION" section.

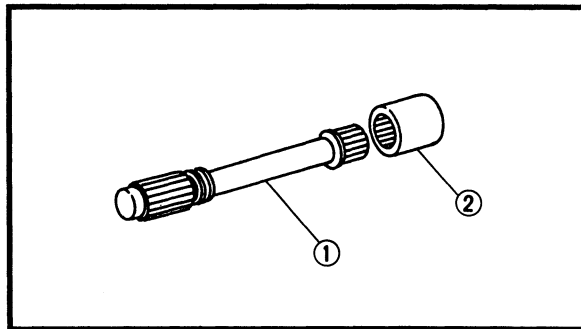

6. Inspect:

- Drive shaft (splines) ①
- Coupling gear (spline) ②
Wear/Damage → Replace.

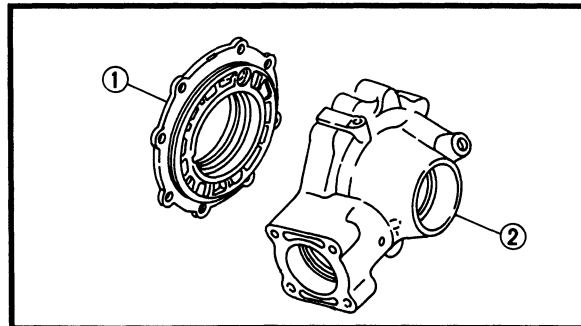

7. Inspect:

- Final gear case ①
- Bearing housing (ring gear) ②
Cracks/Damage → Replace.

NOTE:

When the final gear case and/or ring gear bearing housing are replaced, be sure to adjust the shim of the final drive pinion gear and/or ring gear, refer to "FINAL DRIVE PINION GEAR AND RING GEAR SHIM SELECTION" section.

REAR AXLE/REAR FINAL GEAR AND REAR DRIVE SHAFT



INSTALLATION

Reverse the "REMOVAL" procedures. Note the following points.

1. Lubricate:
- Drive shaft
 - Coupling gear
 - O-ring
 - Oil seal
 - Bearing

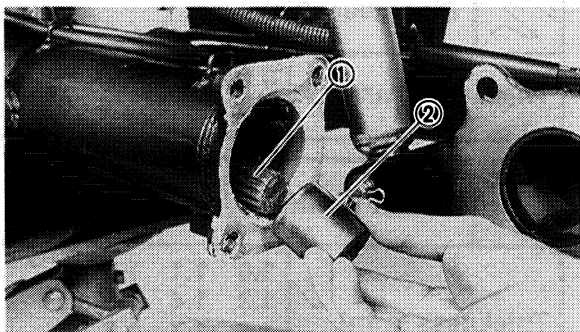

	Lithium soap base grease
---	---------------------------------

2. Install:
- Drive shaft ①
 - Coupling gear ② (to universal joint)

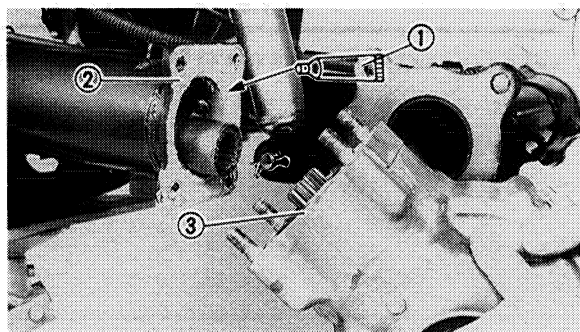

3. Apply:
- Sealant ① (to matching surfaces of swingarm ② and final gear case ③)

	Sealant (Quick Gasket®): ACC-11001-05-01 Yamaha bond No. 1215: 90890-85505
---	---

4. Install:
- Rear final gear assembly ①
 - Breather hose ②

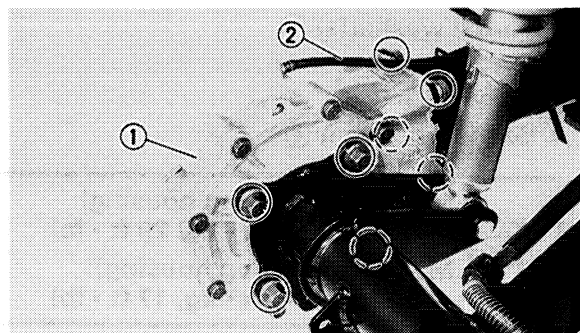

	Nut (final gear): 57 Nm (5.7 m · kg, 41 ft · lb) Bolt (final gear): 63 Nm (6.3 m · kg, 45 ft · lb)
---	---

5. Install:
- Plain washer ①
 - Rear axle ②
 - O-ring ③

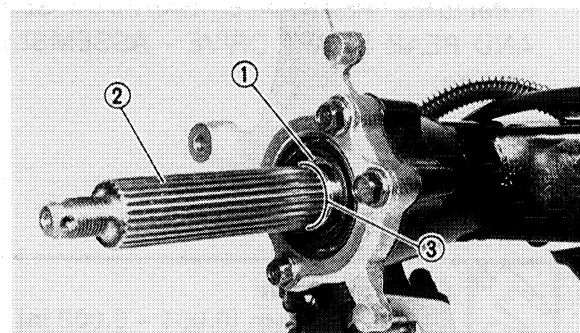

NOTE: Before installing the rear axle, insert the plain washer ① inside the oil seal on the brake caliper bracket.

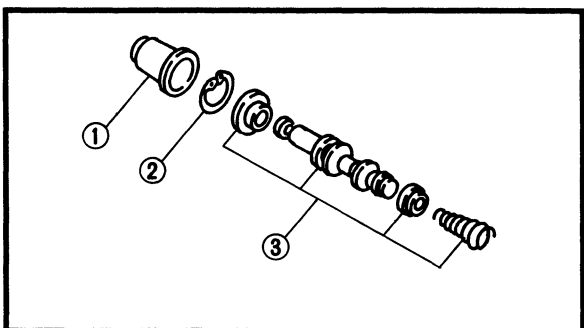

3.Remove:

- Dust boot ①
- Circlip ②
- Master cylinder kit ③
Drain the excess fluid.

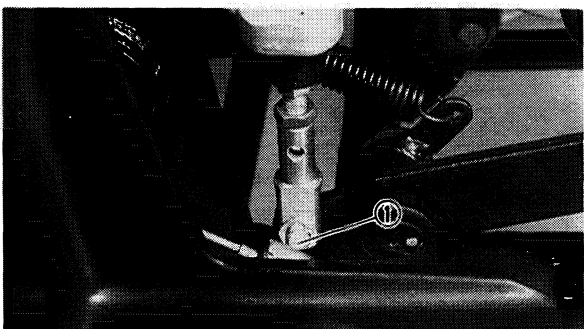

Rear brake

1.Remove:

- Cotter pin
- Washer
- Clevis pin ①

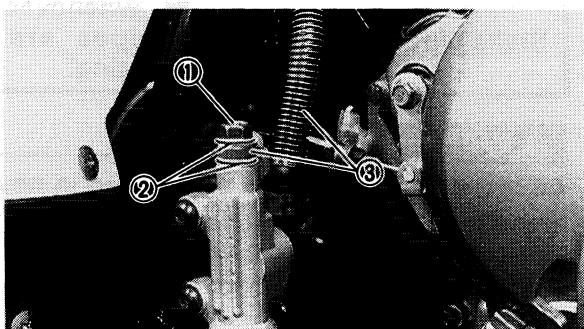

2.Remove:

- Union bolt ①
- Copper washers ②
- Brake hoses ③

NOTE:

Hold a container under the master cylinder and under the hose ends to collect remaining brake fluid.

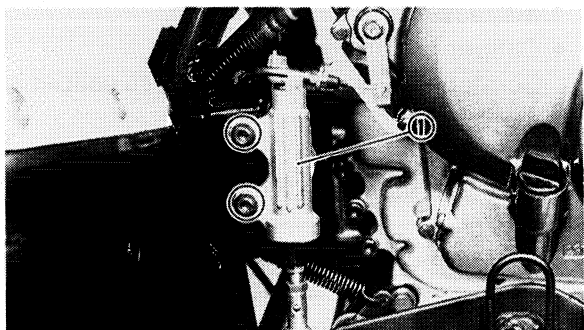

3.Remove:

- Master cylinder ①

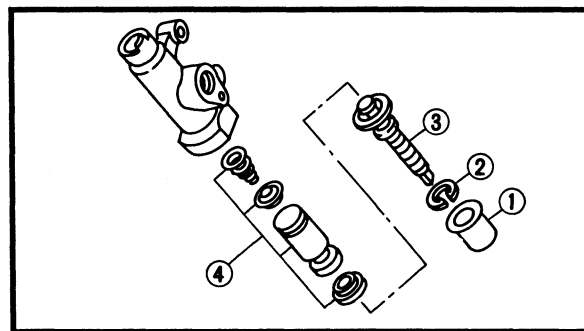

4.Remove:

- Dust boot ①
- Circlip ②
- Push rod ③
- Master cylinder kit ④



10. Air bleed:

- Brake system

Refer to the "AIR BLEEDING" section in CHAPTER 3.

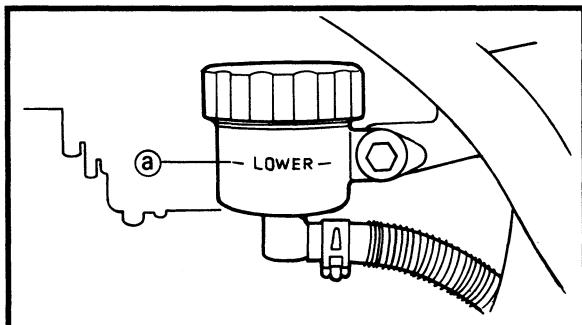

11. Inspect:

- Brake fluid level

Fluid level is under "LOWER" level line → Replenish.

Refer to the "BRAKE FLUID INSPECTION" section in CHAPTER 3.

Ⓐ "LOWER" level line

MASTER CYLINDER ASSEMBLY

⚠ WARNING

- All internal parts should be cleaned in new brake fluid only.
- Internal parts should be lubricated with brake fluid when installed.



Recommended brake fluid:
DOT #4

- Replace the piston seals and dust seals whenever a caliper is disassembled.

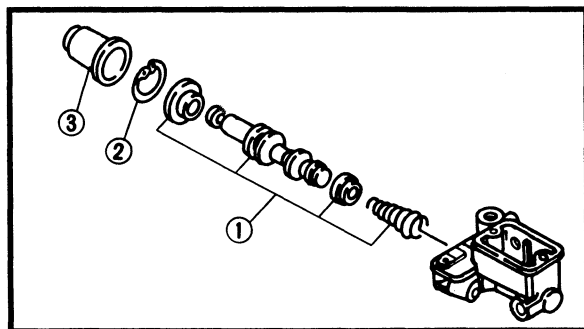

Front brake

1. Install:

- Master cylinder kit ①
- Circlip ②
- Dust boot ③

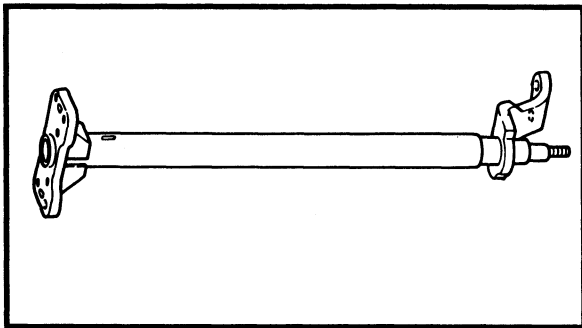

INSPECTION

1. Inspect:

- Steering shaft
Bends → Replace.

⚠ WARNING

Do not attempt to straighten a bent shaft; this may dangerously weaken the shaft.

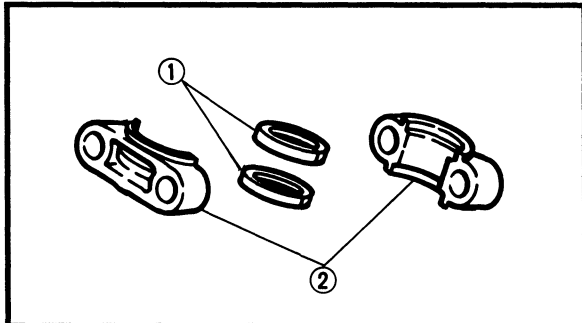

2. Inspect:

- Oil seals ①
- Steering shaft bushings ②
Wear/Damage → Replace.

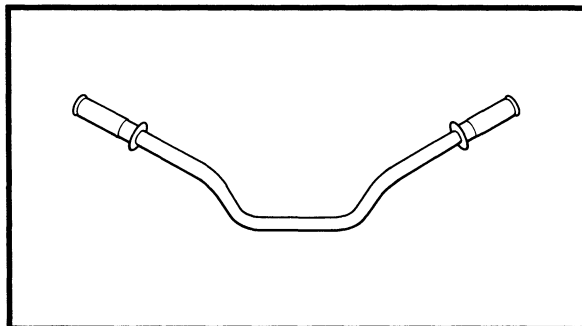

3. Inspect

- Handlebar
Bends/Cracks/Damage → Replace.

⚠ WARNING

Do not attempt to straighten a bent handlebar as this may dangerously weaken the handlebar.

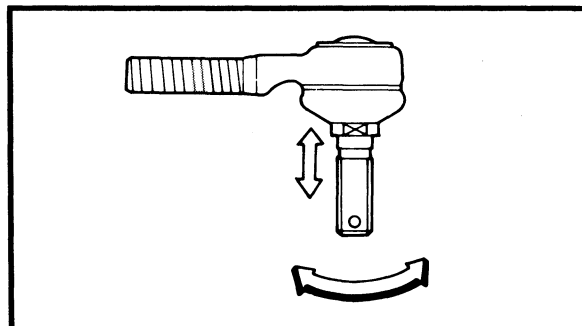

4. Check:

- Tie-rod free play and movement
Tie-rod exists free play → Replace tie-rod end.
Tie-rod is turns roughly → Replace tie-rod end.

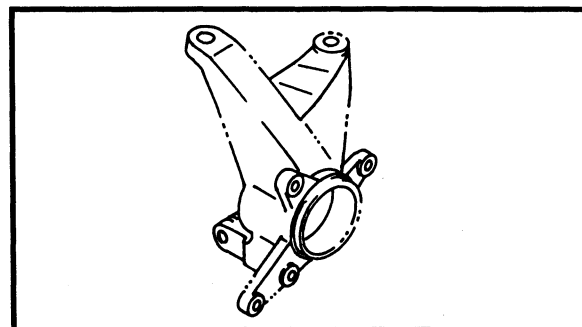

5. Inspect:

- Steering knuckle
Damage/Pitting → Replace.

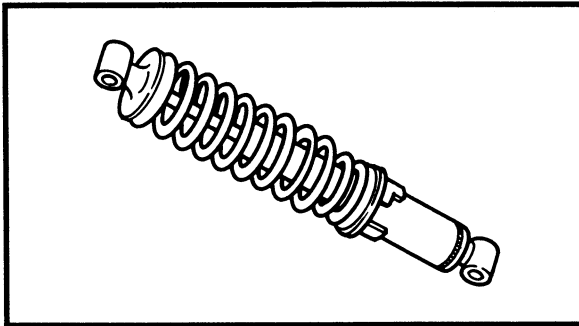

INSPECTION

1. Inspect:

- Shock absorber rod
Bends/Damage → Replace the shock absorber assembly.
- Shock absorber assembly
Oil leaks → Replace the shock absorber assembly.
- Spring
Fatigue → Replace the shock absorber assembly.
Move the spring up and down.

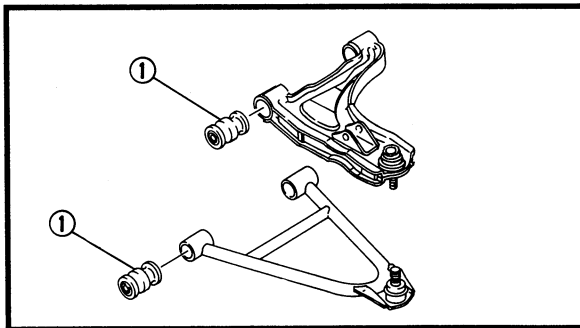

2. Inspect:

- Bushings ①
Wear/Damage → Replace.

INSTALLATION

Reverse the "REMOVAL" procedure.
Note the following points.

1. Lubricate:

- Pivot bolts (front arm)

	Lithium - soap base grease
--	-----------------------------------

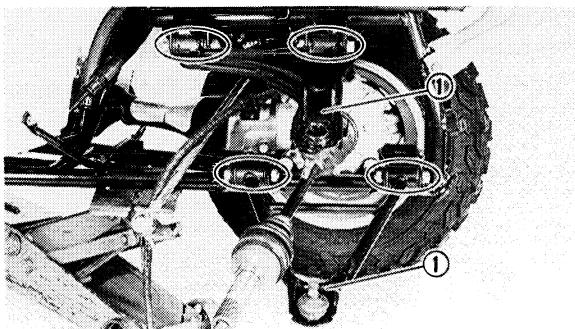

2. Install:

- Front arms ①
- Bolts
- Nuts

NOTE:

- Be sure to position the bolts (upper and lower) so that the bolt head face outward.
- Temporarily tighten the nuts (front arm).

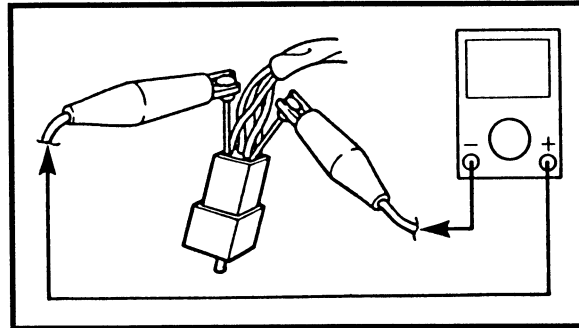
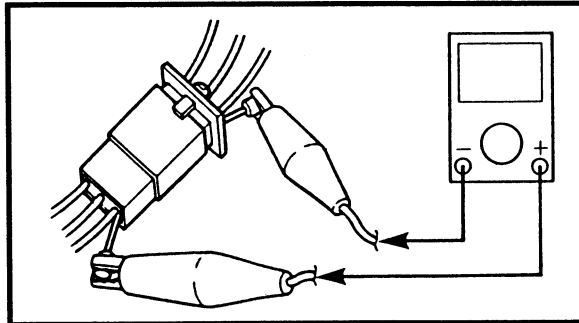
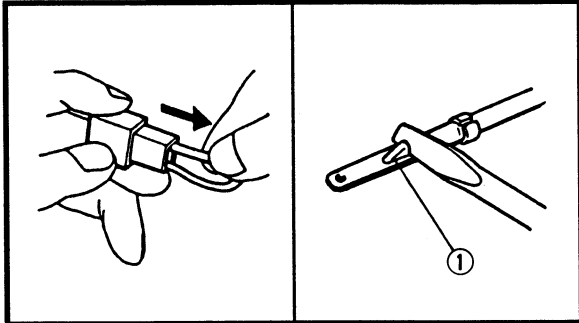
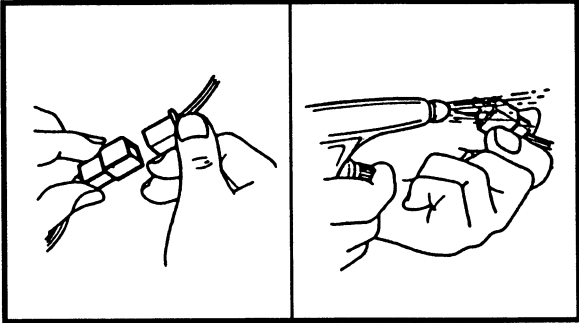

CHECKING OF CONNECTIONS

Dealing with stains, rust, moisture, etc. on the connector.

1. Disconnect:
 - Connector
2. Dry each terminal by an air blower.
3. Connect and disconnect the connector two or three times.
4. Pull the lead to check that it will not come off.
5. If the terminal comes off, bend up the pin ① and reinsert the terminal into connector.

6. Connect:
 - Connector
7. Check for continuity by a tester.

- NOTE:**
- If there is no continuity, clean the terminals.
 - Be sure to perform the above steps 1 to 7 when checking the wireharness.
 - When replacing the CDI unit, be sure to check its connector.
 - For a field remedy, use a contact revitalizer available on the market.
 - Us the tester on the connector as shown.



3. Starter motor

- Connect the battery positive terminal ① and starter motor cable ② using a jumper lead ③ * as shown.

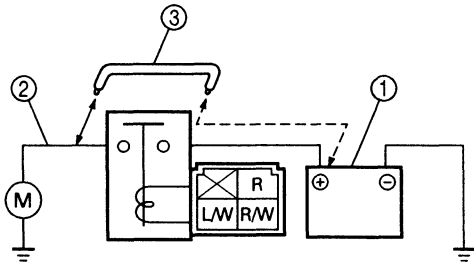

- Check the starter motor for operation.

*

⚠ WARNING

A wire for the jumper lead must have a capacity equivalent to or greater than that of the battery lead. Otherwise it may cause the jumper lead to be burned. This check is likely to produce sparks, so be sure that no flammable gas or fluid is in the vicinity.

DOES NOT MOVE



Starter motor is faulty, repair or replace it.



MOVES

4. Starter relay

- Disconnect the starter relay coupler.
- Connect the pocket tester ($\Omega \times 1$) and battery (12V) to the relay coupler terminals.

Battery (+) terminal → Red/White terminal ①
Battery (-) terminal → Blue/White terminal ②

Tester (+) lead → Red terminal ③
Tester (-) lead → Black terminal ④

- Check the starter relay for continuity.

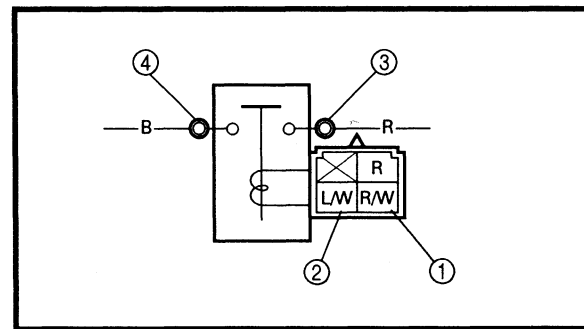

NO CONTINUITY



Starter relay is faulty, replace it.



CONTINUITY

*

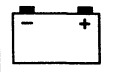

TROUBLESHOOTING

THE BATTERY IS NOT CHARGED.

Procedure

Check:

1. Fuse (main)
2. Battery
3. Charging voltage
4. Stator coil resistance
5. Wiring connection (entire charging system)

NOTE:

- Remove the following parts before troubleshooting.
 - 1) Seat
 - 2) Rear fender
- Use the following special tool(s) in this troubleshooting.

Inductive tachometer:
P/N. YU-08036-A, 90890-03113

Pocket tester:
P/N. YU-03112, 90890-03112

1. Fuse

- Check the fuse condition. Refer to the "FUSE INSPECTION" section in the CHAPTER 3.

INCORRECT



Fuse is faulty, replace it.



2. Battery

- Check the battery condition. Refer to the "BATTERY INSPECTION" section in the CHAPTER 3.

Specific gravity:
1.280 at 20°C (68°C)

INCORRECT



- Refill battery fluid.
- Clean battery terminals.
- Recharge or replace battery



3. Charging voltage

- Connect the inductive tachometer to the spark plug lead.
- Connect the pocket tester (DC20V) to the battery.

Tester (+) lead → Battery (+) terminal
Tester (-) lead → Battery (-) terminal

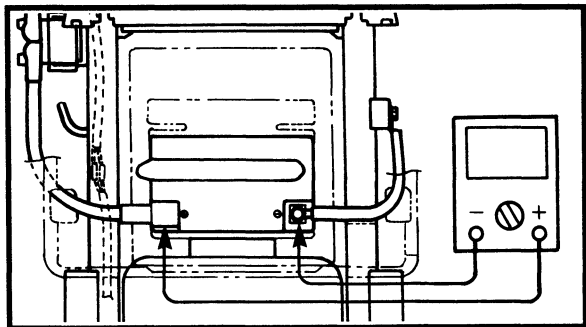

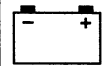

SIGNAL SYSTEM CHECK

1. "NEUTRAL" indicator light does not come on.

1. Bulb and bulb socket

- Check the bulb and bulb socket for continuity.

↓ CONTINUITY

2. Gear position switch

- Disconnect the gear position switch coupler from the wireharness.

- Check the switch component for continuity between the "Brown ① and ground".

↓ CORRECT

3. Voltage

- Connect the pocket tester (DC20V) to the bulb socket connector.

Tester (+) lead → Brown lead ①
Tester (-) lead → Frame ground

- Turn the main switch to "ON".
- Check for voltage (12V) on the "Brown" lead at bulb socket connector.

↓ MEETS SPECIFICATION (12V)

This circuit is good.

NO CONTINUITY

Bulb and/or bulb socket are faulty, replace.

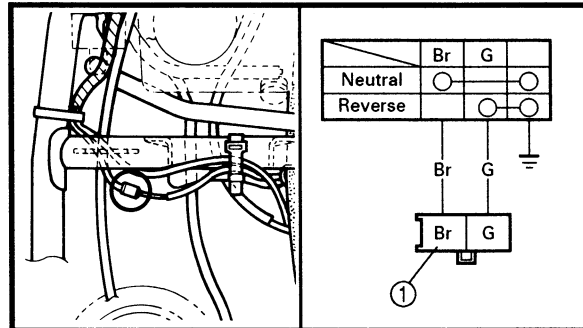

INCORRECT

Gear position switch is faulty, replace it.

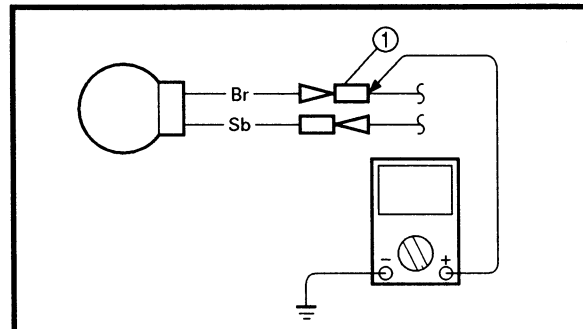

OUT OF SPECIFICATION

Wiring circuit from main switch to bulb socket connector is faulty, repair.



YAMAHA

**YFM350FXM
YFM350FXMG**

**SUPPLEMENTARY
SERVICE MANUAL**



Model	YFM350FX	
Pilot outlet (P.O)	0.85	
Pilot jet (P.J)	#42.5	
Bypass 1 (B.P.1)	0.8	
Bypass 2 (B.P.2)	0.8	
Bypass 3 (B.P.3)	0.8	
Valve seat size (V.S)	2.0	
Starter jet (G.S.1)	#45	
Starter jet (G.S.2)	0.7	
Throttle valve size (Th.V)	#130	
Float height (F.H)	12 ~ 14 mm (0.47 ~ 0.55 in)	
Fuel level (F.L)	2.0 ~ 3.0 mm (0.08 ~ 0.12 in) Above the float chamber mating surface	
Engine idle speed	1,450 ~ 1,550 r/min	
Intake vacuum	33.3 kPa (250 mmHg, 9.8 inHg)	

ELECTRICAL

Model	YFM350FX	
C.D.I.:		
Magneto model/manufacture	F4T423/MITSUBISHI	
Pickup coil resistance/color	459 ~ 561 Ω at 20°C (68°F)/ White/Green-White/Red	
Source coil resistance/color	270 ~ 330 Ω at 20°C (68°F)/Brown-Green	
Lighting coil resistance/color	0.70 ~ 0.86 Ω at 20°C (68°F)/White-White	
C.D.I. unit model/manufacture	F8T32374/MITSUBISHI	
Rectifier:		
Type	Semi conductor-short circuit type	
Model/manufacture	SH640/SHINDENGEN	
No load regulated voltage	14.1 ~ 14.9 V	
Capacity	14 A	
Withstand voltage	200 V	
Electric starter system:		
Type	Constant mesh type	
Starter motor:		
Model/manufacture	DB4DS/DENSO	
I.D. number	DB4DS	
Output	0.7 kW	
Armature coil resistance	0.011 ~ 0.013 Ω at 20°C (68°F)	
Brush overall length	12 mm (0.47 in)	
<Limit>	<8.5 mm (0.33 in)>	
Spring force	650 ~ 950 g (22.9 ~ 33.5 oz)	
Commutator diameter	28 mm (1.10 in)	
<Wear limit>	<27 mm (1.06 in)>	
Mica undercut	0.6 mm (0.02 in)	



DRIVE TRAIN

DIFFERENTIAL GEAR AND CONSTANT VELOCITY JOINTS

- | | | |
|---------------------|---------------------|------------------------------|
| ① Universal joint | ⑧ Boot | ⑮ Differential gear case |
| ② Bearing | ⑨ Washer | ⑯ Ring gear |
| ③ Circlip | ⑩ Spring | ⑰ Differential gear assembly |
| ④ Outer seal | ⑪ Oil seal | ⑱ Bearing housing |
| ⑤ Grease nipple | ⑫ Bearing retainer | (ring gear) |
| ⑥ Dust seal | ⑬ Shim(s) | |
| ⑦ Front drive shaft | ⑭ Drive pinion gear | |

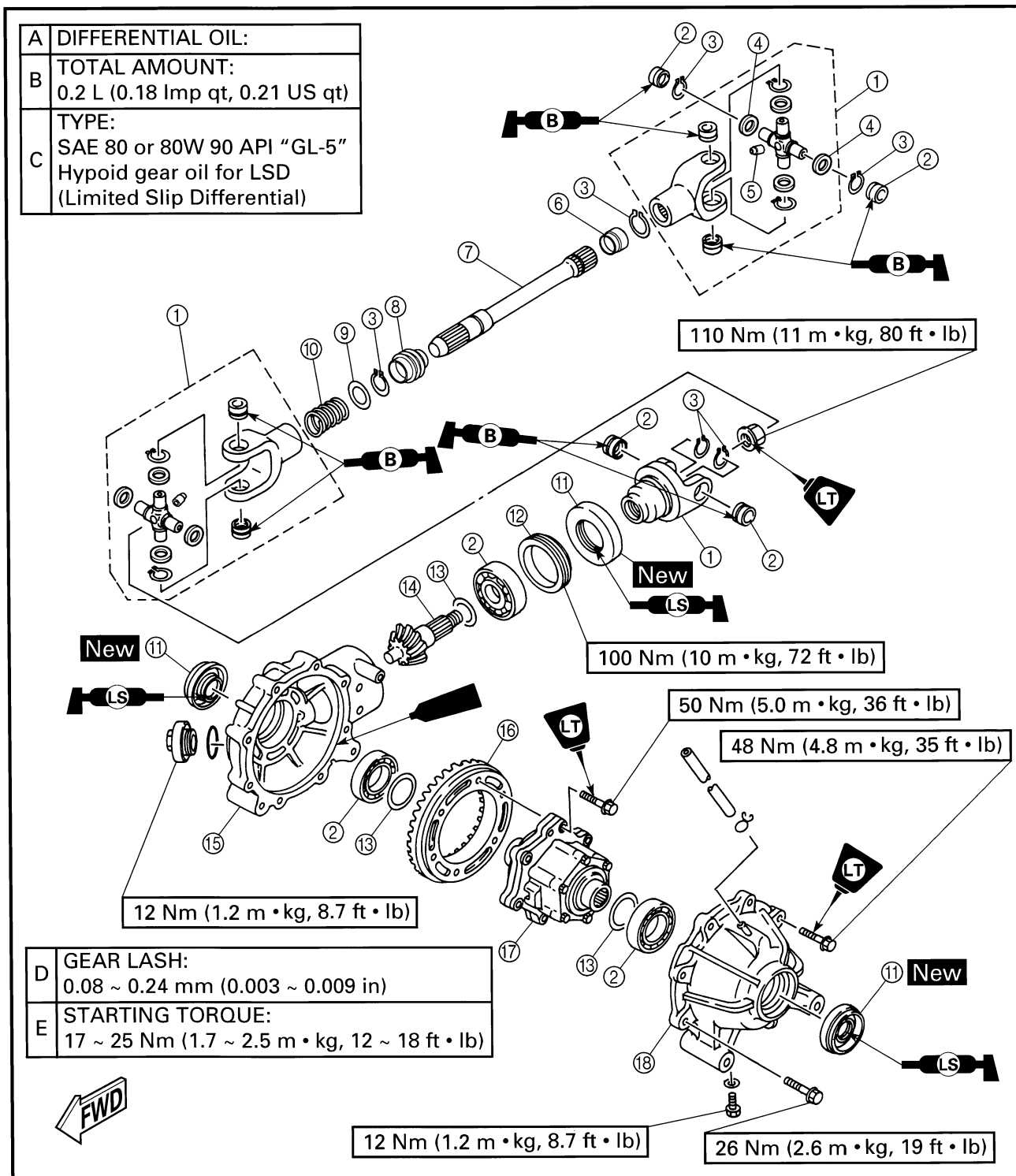

CLICK HERE TO **DOWNLOAD** THE COMPLETE MANUAL

- Thank you very much for reading the preview of the manual.
- You can download the complete manual from: www.heydownloads.com by clicking the link below



- Please note: If there is no response to CLICKING the link, please download this PDF first and then click on it.

CLICK HERE TO **DOWNLOAD** THE COMPLETE MANUAL