

# SERVICE MANUAL

## DI80C Tier 4 Crawler Dozer

Part number 47645621

1<sup>st</sup> edition English

May 2014



CLICK HERE TO **DOWNLOAD** THE COMPLETE MANUAL

- Thank you very much for reading the preview of the manual.
- You can download the complete manual from: [www.heydownloads.com](http://www.heydownloads.com) by clicking the link below



- Please note: If there is no response to CLICKING the link, please download this PDF first and then click on it.

CLICK HERE TO **DOWNLOAD** THE COMPLETE MANUAL

## **Roll over and tip over**

- Travel speed should be such that complete control and machine stability is maintained at all times. Where possible, avoid operating near ditches, embankments and holes. Reduce speed when turning, crossing slopes, and on rough, slick, or muddy surfaces.
- Do not operate the unit on terrain outside its grade and stability limits. Operating the sprayer outside its limits may result in a roll over or tip over.
- Operating the unit on steep grades may result in a machine overturn. It is the operator's responsibility to make a judgment if weather, road or ground conditions permit safe operation on a hillside, ramp, ditch or rough ground.
- Use caution when operating the machine on slopes. Raised equipment, full tanks and other loads can change the center of gravity of the machine. The machine can tip or roll over when near ditches and embankments or uneven surfaces.
- Do not operate the unit near or on the soft shoulders of canals, brooks, other waterways or banks which are undermined by rodents. The unit may sink sideways and roll over.
- Do not operate the unit on poorly constructed or underrated ramps. The ramps may collapse and cause the sprayer to roll over. Always check the condition and rating of ramps before use.
- Do not operate the unit without using the seat restraint.
- Do not operate the unit beyond its limits of dynamic stability. High speed, abrupt maneuvers or fast and sharp cornering increase the risk of roll over.

INTRODUCTION

<b>Thread Locker and Sealing</b>					
<b>Product</b>	<b>Color</b>	<b>Strength</b>	<b>Fixture/Full Cure (Steel/Steel) Time</b>	<b>Recommended Primer or Activator</b>	<b>Description</b>
290	Green	<b>10 - 40 Nm (90 - 355 lb in)</b>	20 min/4 hrs	7471 or 7469	Is designed for the locking and sealing of threaded fasteners. Because of its low viscosity and capillary action, the product wicks between engaged threads and eliminates the need to disassemble prior to application.
425	Dark blue	<b>0.23 - 8.5 Nm (2 - 75 lb in)</b>	2 min/24 hrs	7113	Is designed as a fast curing, low strength adhesive for locking metal and plastics fasteners. The product is designed for pre- or post-application. LOCTITE® 425™ cures quickly on plated metal and plastics fasteners; fixturing is achieved in less than 2 minutes and full strength within 24 hours.



**Engine - 10**

**Fuel tanks - 216**

**D180C**



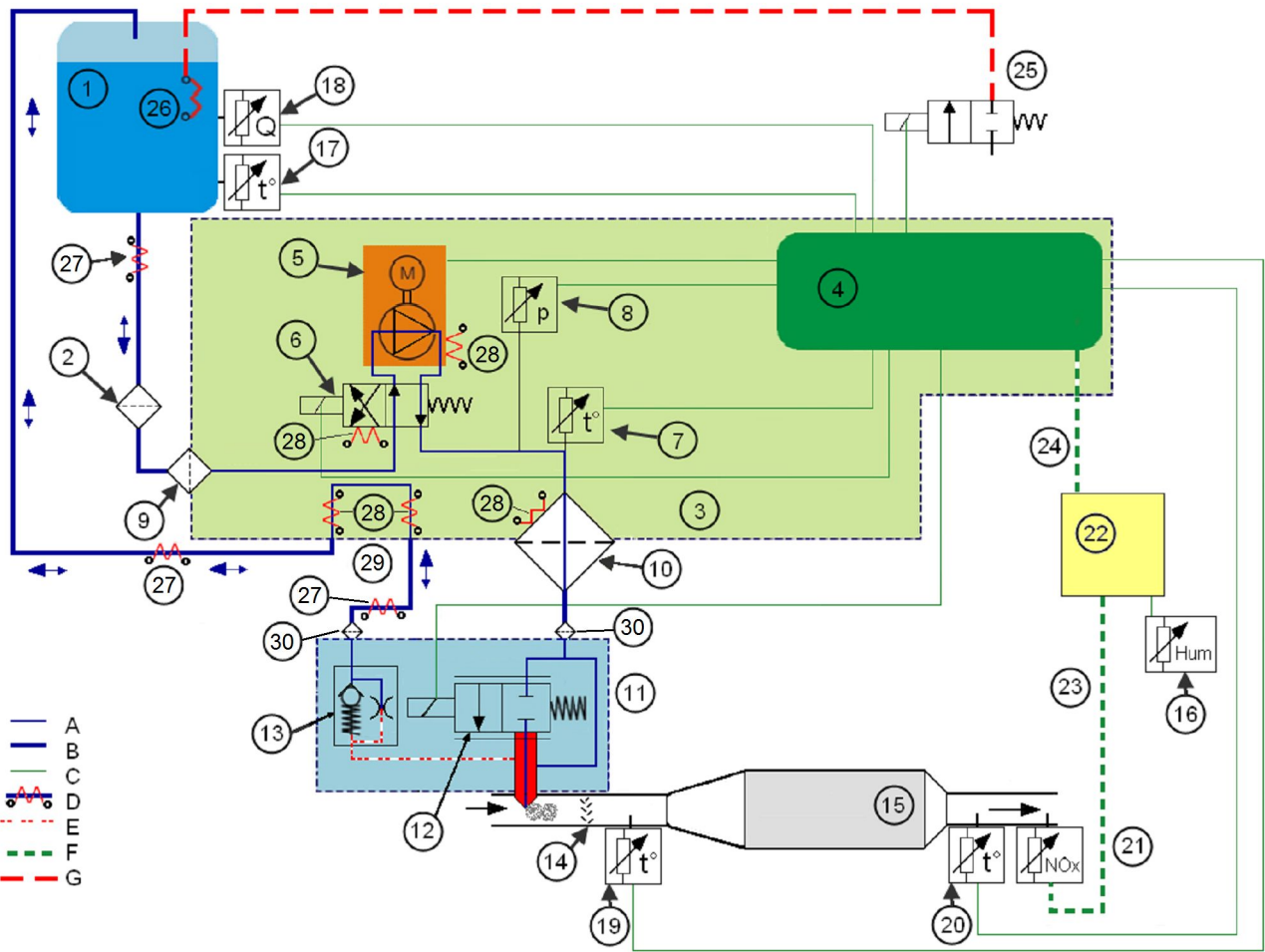

RAIL12DOZ542GA 1

**SCR System Components**

**Graphic Legend**

- |                       |                           |
|-----------------------|---------------------------|
| A – DEF fluid passage | D – Heater                |
| B – DEF fluid hose    | E – CAN wire              |
| C – Electrical wiring | F – Dosing module cooling |

**Components**

- |                                     |   |
|-------------------------------------|---|
| 1 – Diesel Exhaust Fluid (DEF) tank | 16 – Humidity sensor                        |
| 2 – Inline filter                   | 17 – DEF tank temperature sensor            |
| 3 – Supply module                   | 18 – DEF tank level sensor                  |
| 4 – Denox Control Unit (DCU)        | 19 – Catalyst inlet temperature sensor      |
| 5 – Pump                            | 20 – Catalyst outlet temperature sensor     |
| 6 – Reversing valve                 | 21 – NOx sensor                             |
| 7 – DEF temperature sensor          | 22 – Engine Control Unit (EDC7UC31)         |
| 8 – DEF pressure sensor             | 23 – CAN wire (from NOx sensor to ECU)      |
| 9 – Prefilter                       | 24 – CAN wire (between DCU and ECU)         |
| 10 – Filter                         | 25 – DEF tank heater solenoid               |
| 11 – Dosing module                  | 26 – DEF fluid heating coolant coil in tank |
| 12 – Dosing valve                   | 27 – Coolant line DEF fluid heater          |
| 13 – Return flow valve              | 28 – Electrical DEF fluid heater            |
| 14 – Mixer                          | 29 – Return Flow Passage in supply module   |
| 15 – Catalyst                       | 30 – Dosing module screens                  |

13. Connect the left engine access door prop rod to the machine.

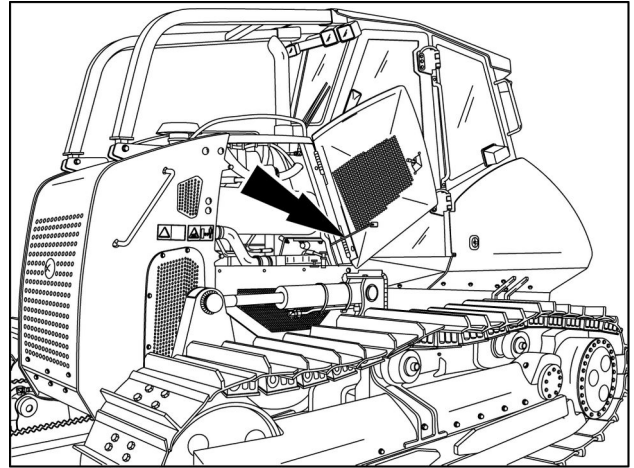

RAIL14DOZ0277AA 10

14. With the aid of a helper, install the right engine access door (1) to the machine using three inner door hinge mounting bolts and washers (2). Tighten the bolts.

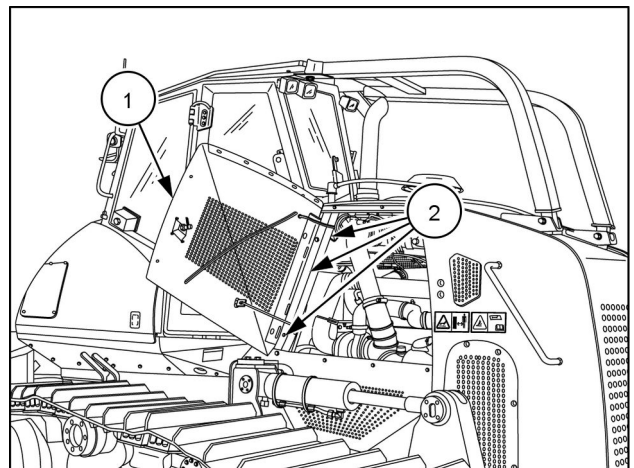

RAIL14DOZ0150AA 11

15. Connect the right engine access door prop rod to the machine.

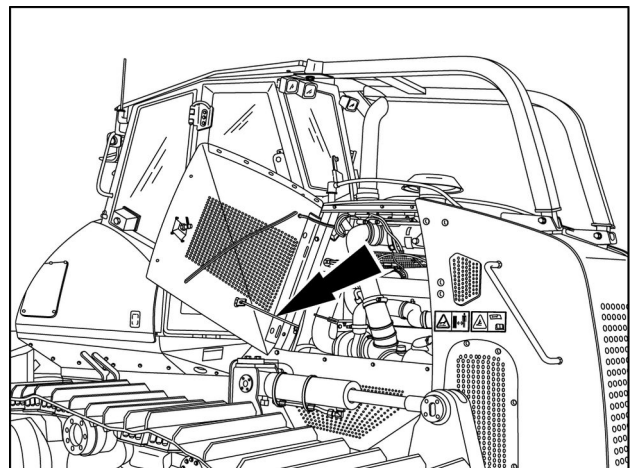

RAIL14DOZ0150AA 12

16. Install the hood to the machine. See **Hood - Install (90.100)**.
17. Check the cooling system level and add as required.
18. Start and run the engine for 30 seconds. Stop the engine. Check for leaks.
19. Check the cooling system level and add as required.

11. Disconnect the backflow outlet hose (**B**) and the backflow inlet hose (**A**).

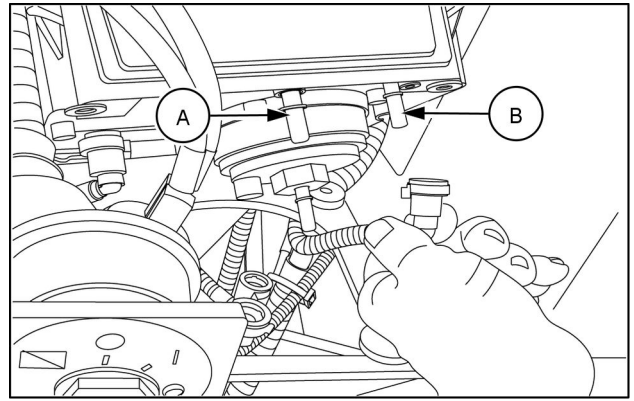

RAPH12DOZ1170AA 8

12. Raise the module off the bracket and retrieve the washers. Save the washers for reuse.

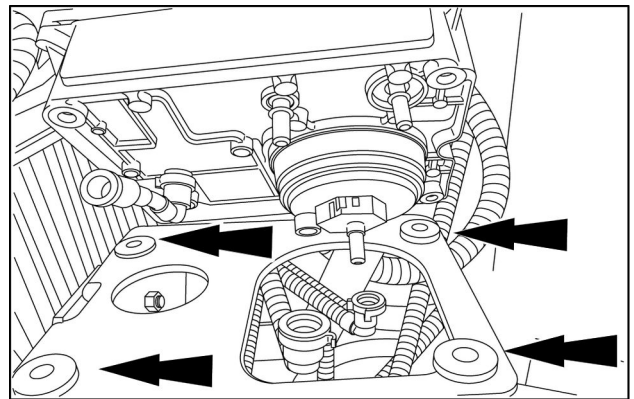

RAPH12DOZ1172AA 9

13. Remove the module from the bracket.

**NOTE:** Do not lose the grommets on the bracket.

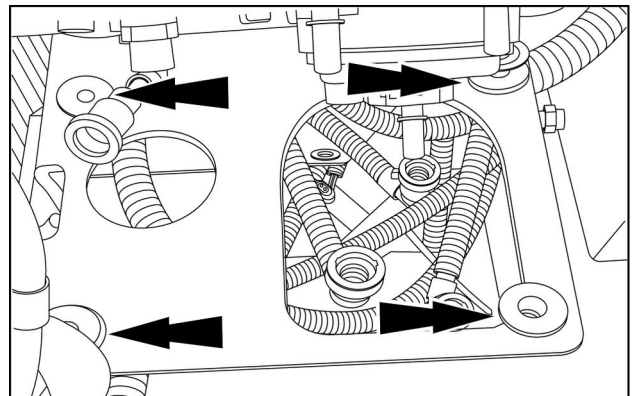

RAPH12DOZ1171AA 10

14. Disconnect the electrical connector from the rear of the module and remove the module from the machine.

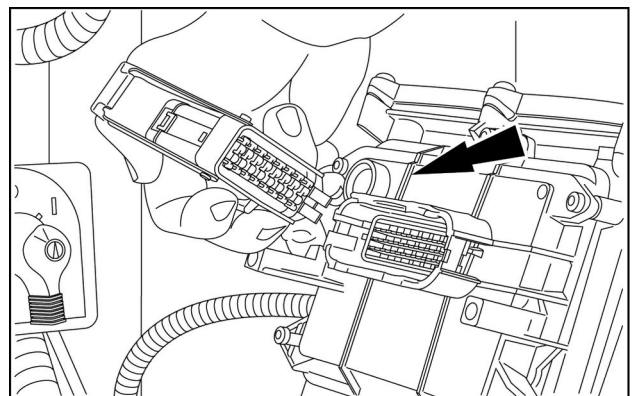

RAPH12DOZ1175AA 11

14. Remove two bolts (1) and two bolts and washers (2) from the top of the radiator/hydraulic oil cooler support plate (3).

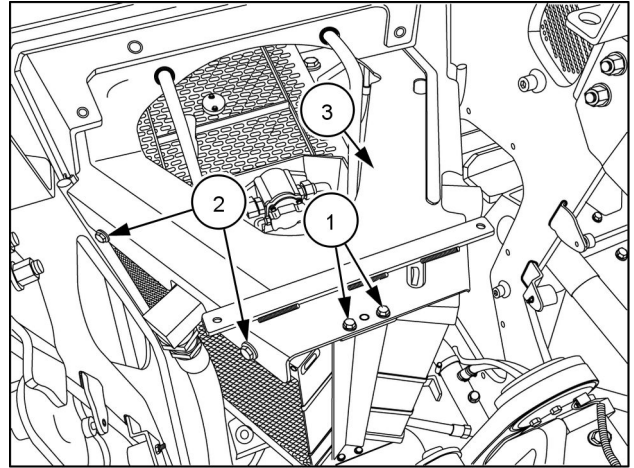

RAIL14DOZ0173AA 9

15. Remove two nuts, bolts, and washers (1) from the front side of the radiator/hydraulic oil cooler support plate. Remove two bolts (2) from radiator/hydraulic oil cooler support plate that are accessed through the fan shroud.

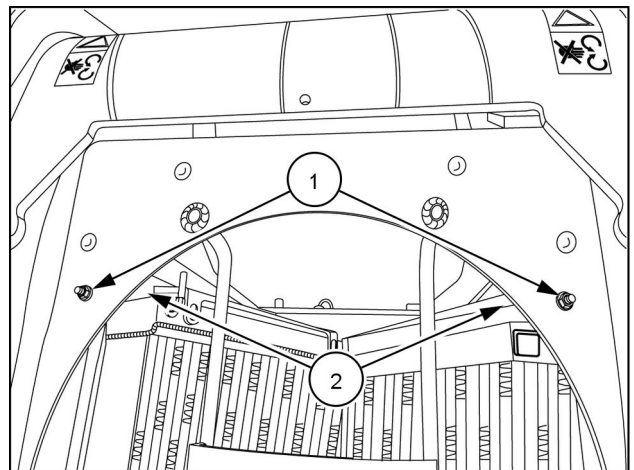

RAIL14DOZ0172AA 10

16. Remove two upper spring clips and pins (1) from the radiator/hydraulic oil cooler support plate. Remove the support plate from the machine.

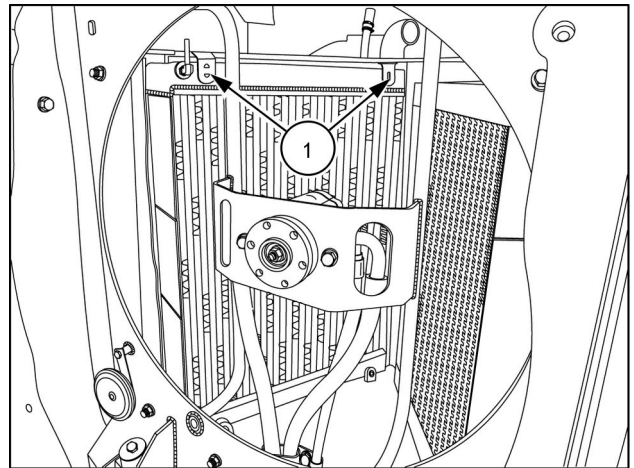

RAIL14DOZ0171AA 11



**Engine - 10**

**Aftercooler - 310**

**D180C**

12. Turn the valve cover over and press the vent system out of the valve cover.

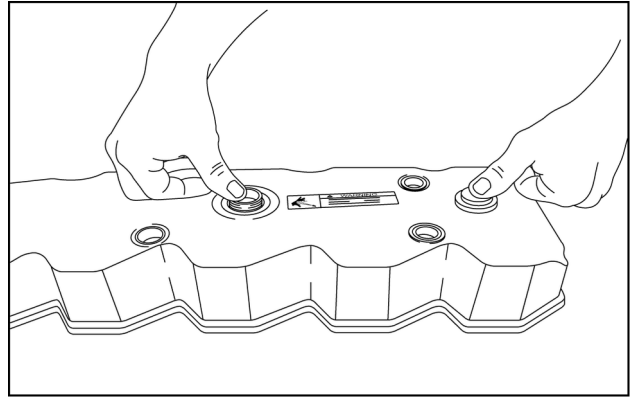

RAPH12DOZ0291AA 12

13. Separate the canister from the foam filter.

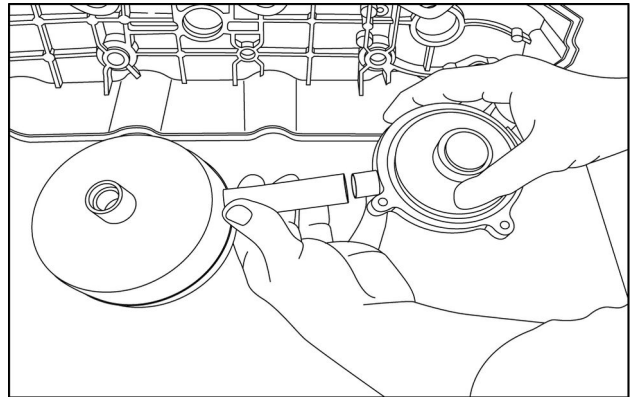

RAPH12DOZ0294AA 13

14. Open the foam filter assembly.

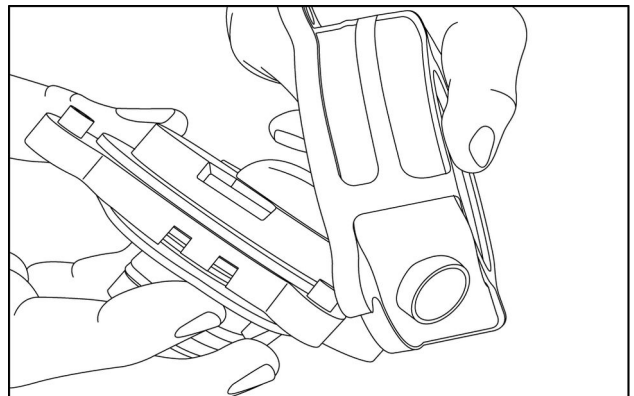

RAPH12DOZ0278AA 14

15. Remove and clean the foam filter. Replace parts as necessary.

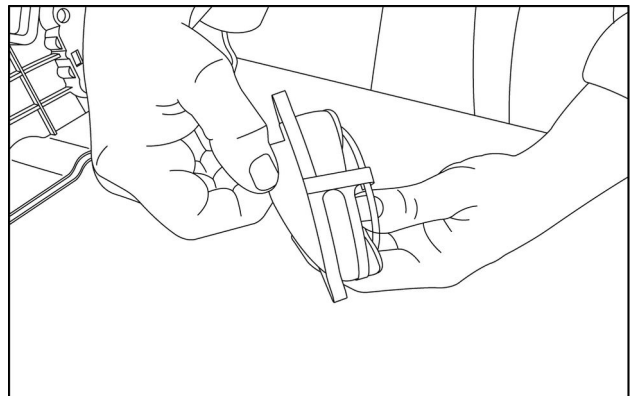

RAPH12DOZ0295AA 15

**Next operation:**  
**Blow-by recirculation system - Install (10.304)**

(4)	The tab is <b>9.52 mm (0.4 in)</b> high and the cut in from the end is <b>12.7 mm (0.5 in)</b> .
(5)	The plates are <b>50.8 mm (2.0 in)</b> wide.

4. Run a diagonal weld on both sides of the bracing plate.

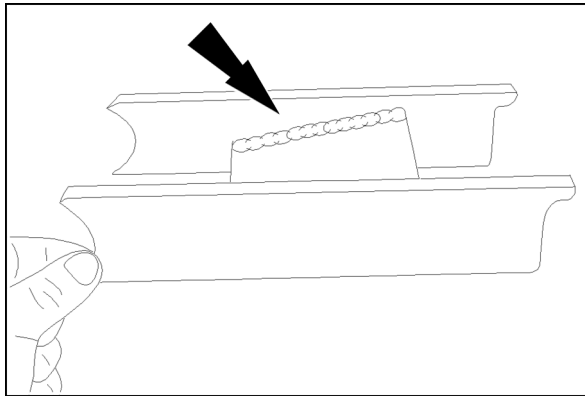

BD07N468-01 3

5. The pin used is a bucket pin from a backhoe, a pin of equal size and hardness can be used in it's place.

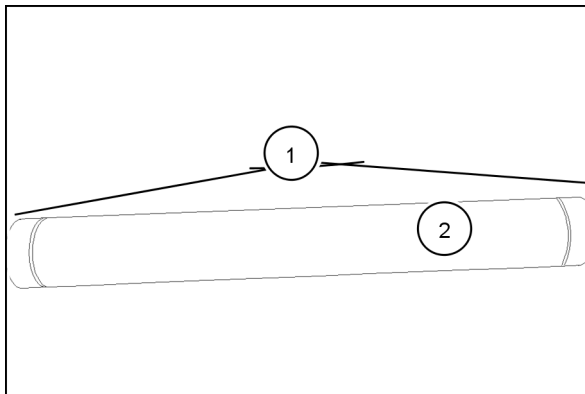

BD07N469-01 4

(1)	The length of the pin used is <b>371.5 mm (14.63 in)</b> .
(2)	Diameter of the pin used is <b>44.4 mm (1.75 in)</b> .

6. Install the pin and bracket at each sprocket. To test the reverse relief valves, only the pins are required. In reverse, the pin will lock between the sprocket and the rear end of the track frame.

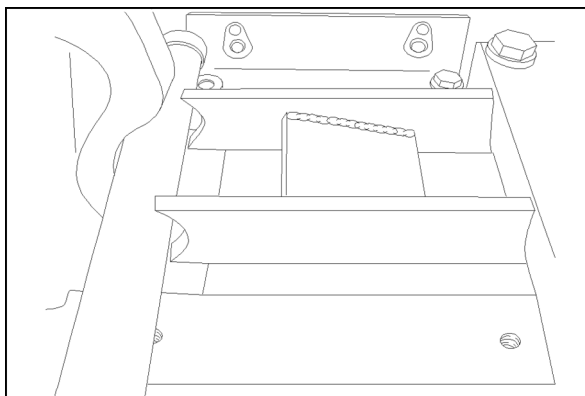

BD07N470-01 5

## Hydrostatic circuit supply pump - Install

**NOTICE:** Always install new O-ring to right hydrostatic drive pump. Never reuse O-ring when assembling hydrostatic drive pumps.

1. Install new O-ring to mounting flange of the right hydrostatic drive pump.

**NOTICE:** The right hydrostatic pump weighs approximately **117.9 kg (260 lb)**. Use appropriate lifting equipment to prevent personal injury or property damage.

2. Attach an appropriate lifting device to the right hydrostatic drive pump.

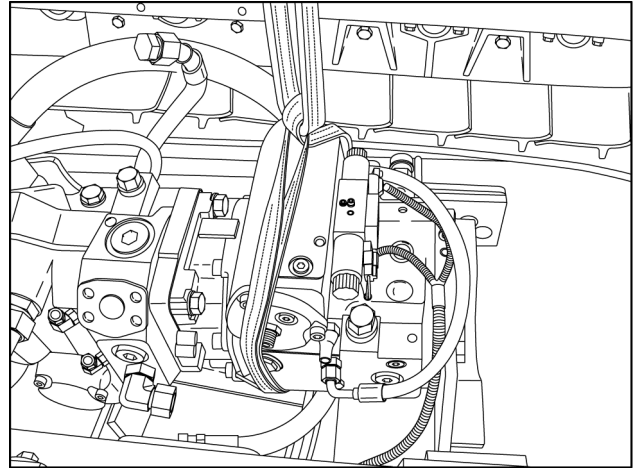

3. Install right hydrostatic drive pump to left hydrostatic drive pump.

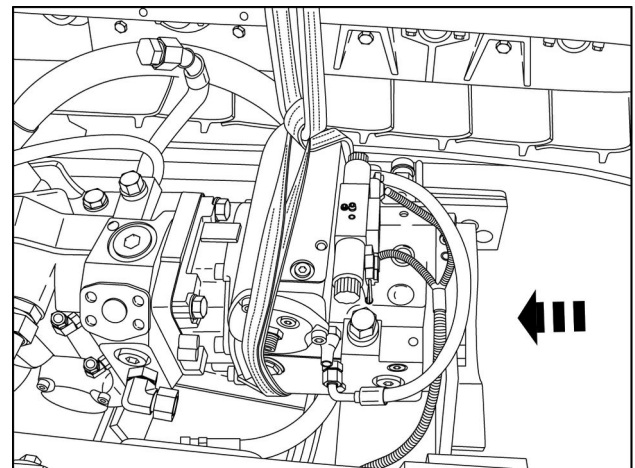

4. Apply **LOCTITE® 242** and install four mounting bolts and washers (**1**) to the right hydrostatic drive pump (**2**). Tighten the bolts.

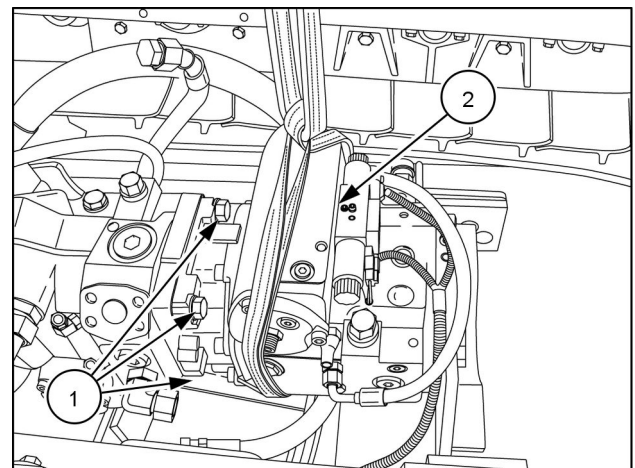

- 5.

9. Connect two electrical connectors (1) to the hydrostatic ground drive motor (2).

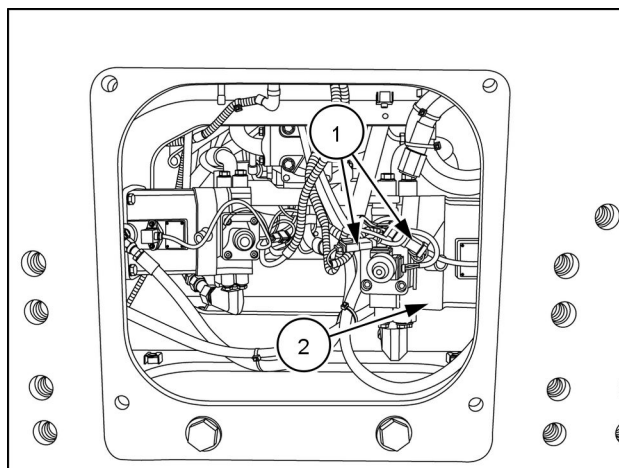

RAIL12DOZ0766BA 3

10. Connect the negative (-) battery cable (1) to the battery negative terminal (2).

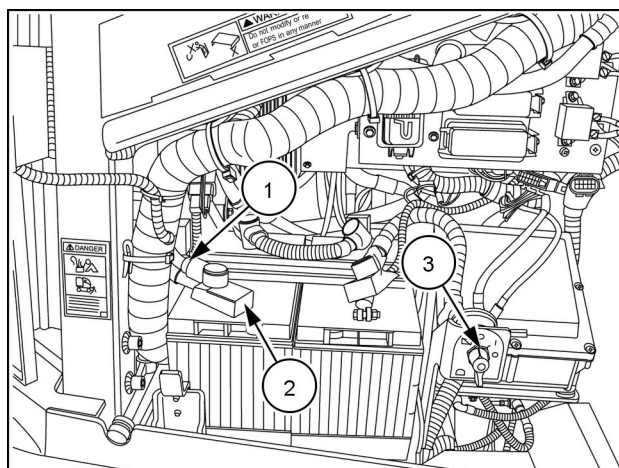

RAIL12DOZ0927BA 4

11. Turn the master battery disconnect switch (3) to the ON position.
12. Close the battery access door.

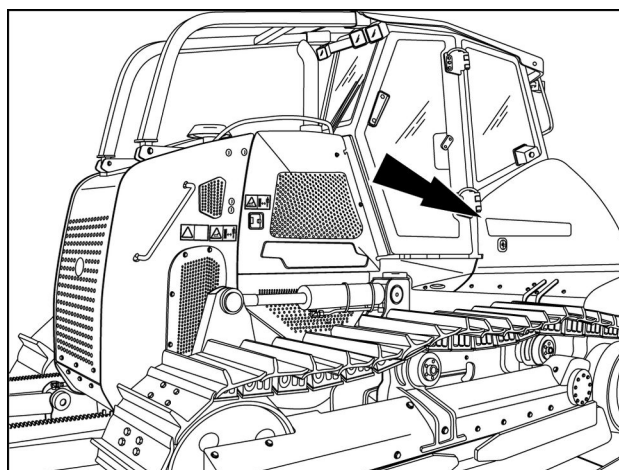

RAIL14DOZ0175AA 5

13. Check the oil level in the hydraulic oil reservoir and add as required.

**NOTICE:** Keep hands and body away from any pressurized leak. DO NOT use your hand to check for leaks. Use a piece of cardboard or paper. If fluid penetrates the skin, seek medical attention immediately.

14. Start and run the engine for 30 seconds. Stop the engine. Check for leaks.

# Contents

---

## Hydraulic systems - 35

[35.300] Reservoir, cooler, and filters.....	35.1
[35.104] Fixed displacement pump.....	35.2
[35.106] Variable displacement pump .....	35.3
[35.105] Charge pump.....	35.4
[35.359] Main control valve.....	35.5
[35.741] Dozer blade cylinders .....	35.6
[35.525] Auxiliary hydraulic valves and lines .....	35.7
[35.752] Hydraulic fan drive cooling system.....	35.8
[35.000] Hydraulic systems.....	35.9

12. Remove two bolts (1) and two bolts and washers (2) from the top of the radiator/hydraulic oil cooler support plate (3).

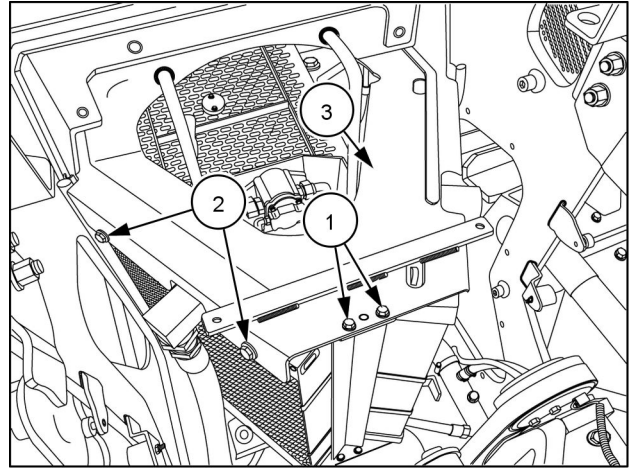

RAIL14DOZ0173AA 6

13. Remove two nuts, bolts and washers (1) from the front side of the radiator/hydraulic oil cooler support plate. Remove two bolts (2) from radiator/hydraulic oil cooler support plate that are accessed through the fan shroud.

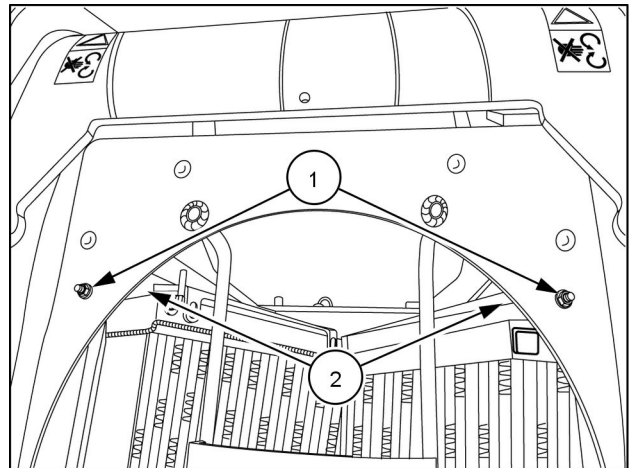

RAIL14DOZ0172AA 7

14. Remove two upper spring clips and pins (1) from the radiator/hydraulic oil cooler support plate. Remove the support plate from the machine.

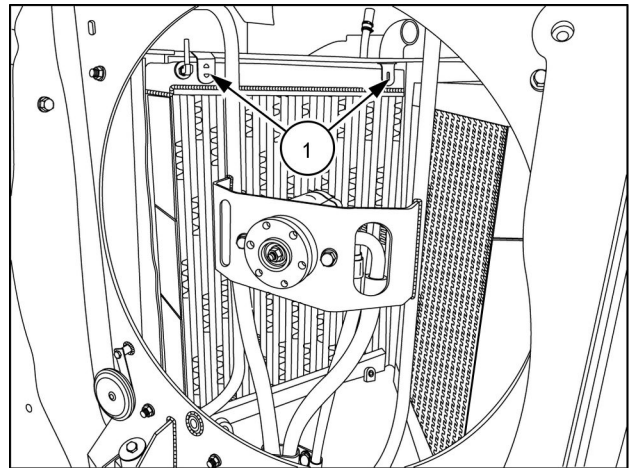

RAIL14DOZ0171AA 8

15. Install equipment and apply a vacuum to the hydraulic system.

**NOTICE:** During the disassembly of components with O-ring seals, the seals should be discarded and new seals installed during assembly.

# Contents

---

## Hydraulic systems - 35

### Variable displacement pump - 106

#### SERVICE

##### Variable displacement pump

Remove – Equipment (Implement) pump ..... 3

Install – Equipment (Implement) pump ..... 4

## Stacked control valves - Torque

Special torques	Nm	lb
Bolts and nuts that fasten the sections together	39 - 47 Nm	28.7 - 34.6 lb ft
Relief valves and load check valves	24 - 30 Nm	17.7 - 22 lb ft
Allen head screws	12 - 15 Nm	106 - 133 lb in
Centering spring screw	13 - 16 Nm	115 - 142 lb in

## Stacked control valves - Special tools

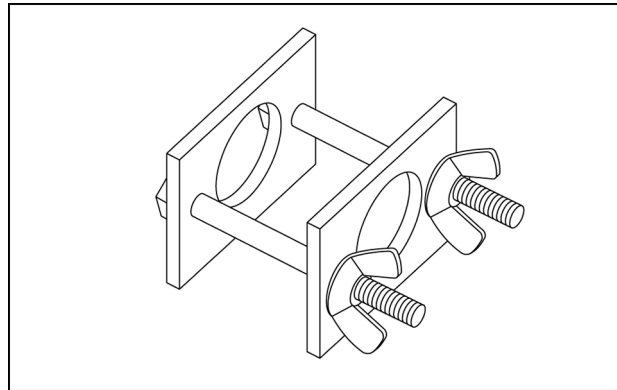

RCPH09CWL075AAD 1

Centering spring compression tool

## Stacked control valves - General specification

Spool travel	MM	Inch
Neutral to pressure - lift, tilt and auxiliary	7.9 mm	0.31 in
Neutral to pressure - angle section	6.6 mm	0.26 in
Neutral to float - lift	13.5 mm	0.53 in

# Contents

---

## Hydraulic systems - 35

### Auxiliary hydraulic valves and lines - 525

#### SERVICE

Manifold block	
Remove .....	3
Install .....	6

# Index

---

## Hydraulic systems - 35

### Hydraulic fan drive cooling system - 752

Fan motor - Install .....	6
Fan motor - Remove .....	3

36. Start and run the engine at 1500 rpm (r/min).
37. Completely retract the cylinders of all attachments on the machine. Angle the blade to the right, the right cylinder will be fully retracted and the left will be fully extended. Stop the engine.

**NOTICE:** *If retracting the cylinder rods causes the attachment to be raised, block the attachment in place before proceeding to the next step.*

38. Move each control lever in both directions to release pressure in the hydraulic circuits.
39. Loosen and remove the filler cap from the reservoir.
40. Drain the hydraulic oil from the reservoir.  
**(A)** The reservoir holds approximately **210 L (55.5 US gal)** of hydraulic oil.  
**(B)** Have available acceptable equipment to drain the hydraulic oil.  
**(C)** Remove the drain plug from the bottom of the reservoir.
41. Remove the hydraulic and hydrostatic filter elements from the machine.
42. Install new hydraulic and hydrostatic filter elements on the machine.
43. Install the drain plug in the bottom of the reservoir.
44. Fill the hydraulic reservoir with lubricant, refer to **Capacities ( )** for proper quantities and type.
45. Disconnect the line from the OPEN end and CLOSED end of each cylinder.
46. Be sure all control levers are in the NEUTRAL position.
47. Start and run the engine at low idle.

**NOTICE:** *Check the oil level in the hydraulic reservoir frequently while doing step 48. Have another person hold a container under the hydraulic lines while you do step 48.*

48. Slowly move each control lever in both directions until oil begins to flow from the open line. Hold the control lever in place until clean oil flows from the open line.
49. Stop the engine.
50. Connect the system line to the CLOSED end of each cylinder.
51. Connect a suitable drain line to the OPEN end of each cylinder and place the other end in an acceptable container for contaminated oil.
52. Start the engine and run the engine at low idle.
53. Slowly and completely extend all cylinders. As the piston rod comes in/out of the cylinder, oil will be pushed out of the OPEN end of the cylinders.

**NOTICE:** *Any attachment or part of an attachment that is raised must be supported with acceptable equipment to prevent the attachment from falling.*

54. Support any attachments that will be in the RAISED position.

18. Remove the retaining clamps **(1)** from the turbocharger-to-SCR exhaust pipe **(2)**. Disconnect the V-band clamp **(3)** at the turbocharger **(4)**, and remove the turbocharger-to-SCR exhaust pipe from the machine. Close all openings.

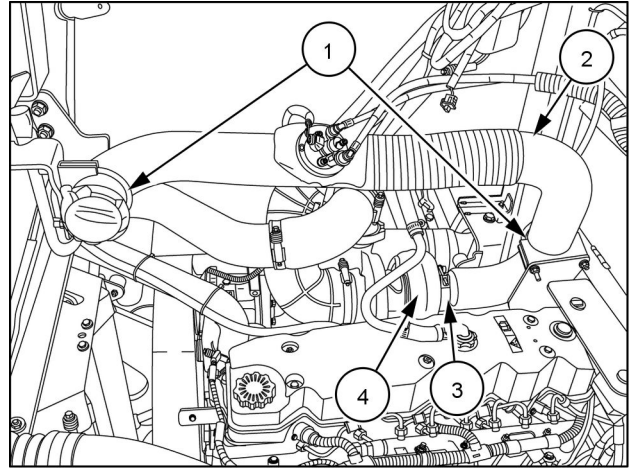

RAIL14DOZ0004AA 14

19. Loosen two hose clamps **(1)** from the left charge air cooler pipe **(2)**, and remove the left charge air cooler pipe from the machine. Close all openings.

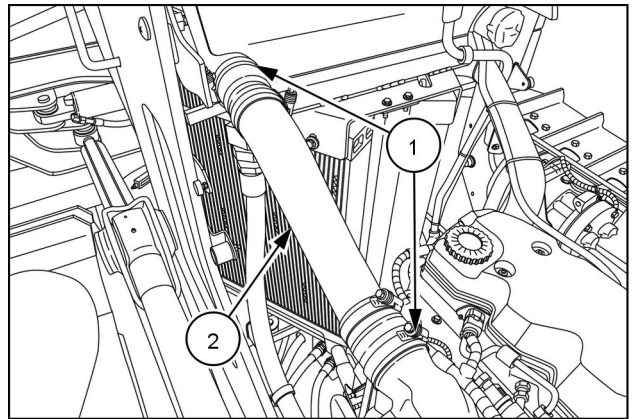

RAIL14DOZ0014BA 15

20. Disconnect the cooling system quick fill hose **(1)** from the quick fill fitting **(2)**. Cap and plug all openings to prevent fluid loss or contamination.

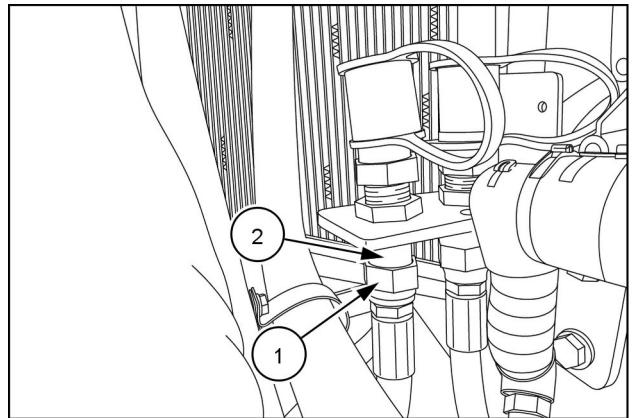

RAIL14DOZ0017BA 16

21. Disconnect the lower ECU electrical connector **(1)** from the ECU **(2)**.

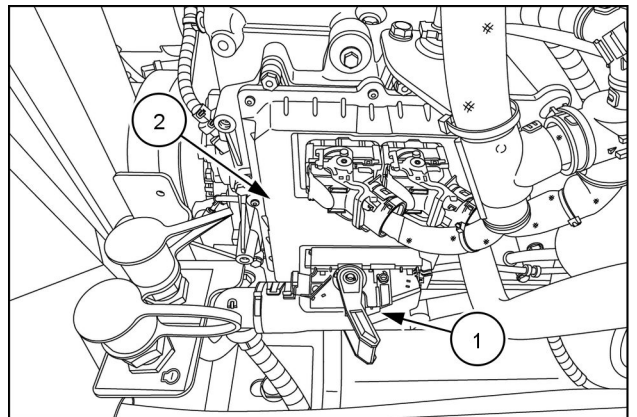

RAIL14DOZ0016BA 17

## Frame - Install

**NOTICE:** The frame, engine, and pump stack assembly weighs approximately **1225 kg (2700 lb)**. Use appropriate lifting equipment to prevent personal injury or property damage.

**NOTICE:** The frame, engine, and pump stack assembly **MUST BE** balanced as shown, or personal injury or property damage will occur.

**NOTE:** The frame, engine and pump stack assembly is shown removed to show appropriate lifting points.

1. Attach an appropriate lifting device to the frame, engine, and pump stack assembly.

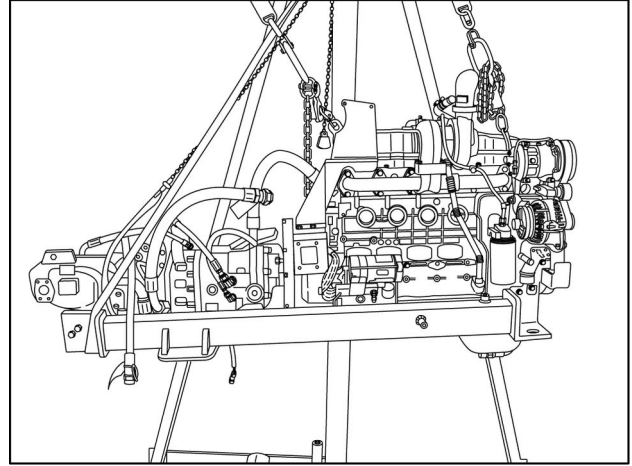

RAIL14DOZ0072BA 1

2. Install the frame, engine, and pump stack assembly to the machine.
3. Install the left front (1) and right front (2) rubber bushings, washers, bolts, and nuts to the engine and pump stack frame. Torque the bolts to **185 - 200 N·m (136 - 148 lb ft)**.

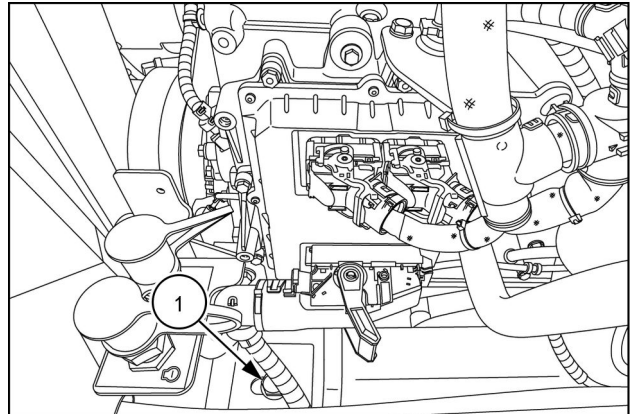

RAIL14DOZ0016BA 2

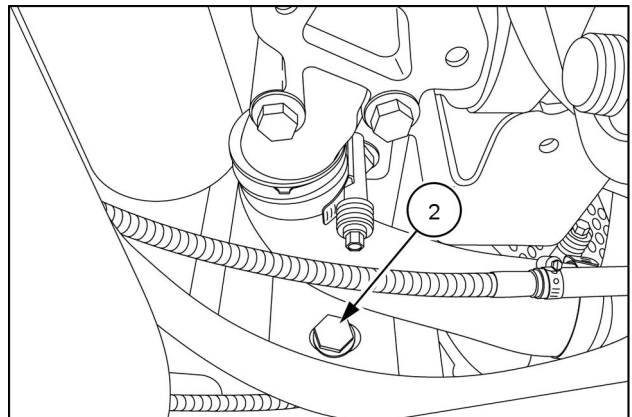

RAIL14DOZ0010AA 3

74. Connect the electrical connections **(1)** to the starter **(2)**.

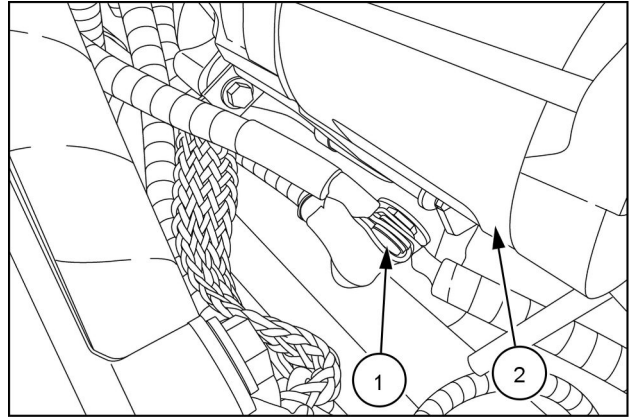

RAIL14DOZ0013BA 53

75. Install the upper radiator hose **(1)** to the radiator. Secure with a clamp **(2)**. Secure the cooling system air bleed hose **(3)** to the upper radiator hose using wire ties as noted during removal.

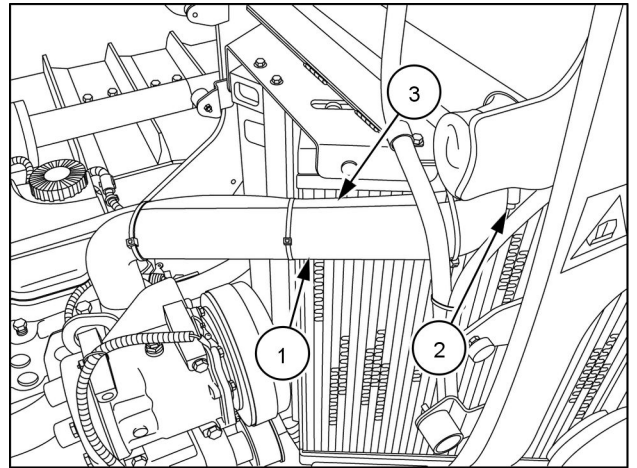

RAIL14DOZ0034BA 54

76. Connect the upper radiator hose **(1)** and the cooling system air bleed hose **(2)** to the top of the engine. Secure with clamps **(3)**.

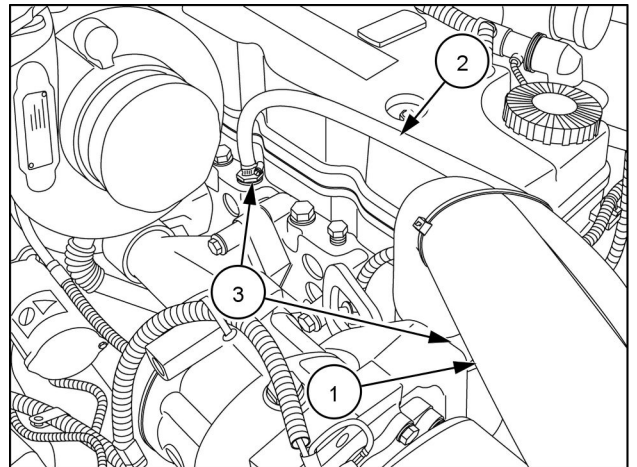

RAIL14DOZ0033BA 55

17. Remove the nuts and washers **(2)** and remove drive sprockets **(3)**.

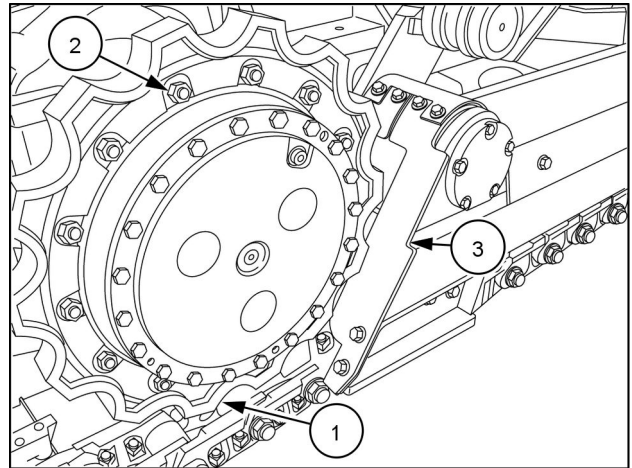

RAIL12DOZ0775BA 9

**NOTE:** Steps **(18)** through **(20)** only required for left drive motor.

18. Apply vacuum to hydraulic system.  
 19. Remove rigid hydraulic return pipe **(1)** from left drive motor.  
 20. Remove vacuum hydraulic system.  
 21. Disconnect electrical connectors **(2)**.

**NOTICE:** The drive motor is heavy. Use proper lifting equipment to prevent personal injury or property damage.

22. Attach an appropriate lifting device to the drive motor.  
 23. Remove four bolts **(3)** and remove the drive motor.

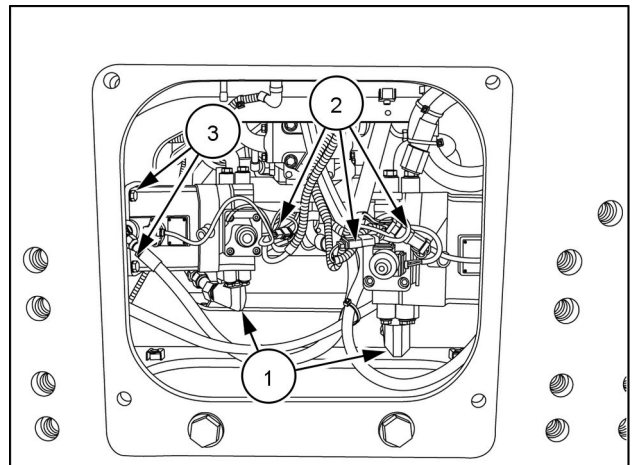

RAIL12DOZ0766BA 10

**NOTICE:** The energy stored in a compressed spring can cause personal injury or property damage. Disassemble and assemble with caution.

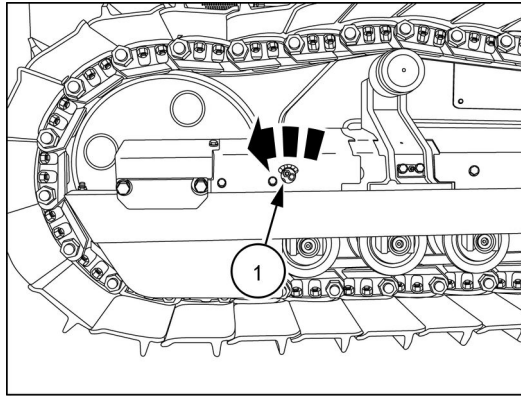

RAIL12DOZ0742BA 3

8. Use an appropriate lifting device to lift the top of the track and compress track adjuster piston as far as possible.
9. Remove lifting device from track.
10. Support lower section of track to prevent injury when master link is separated.
11. Remove the bolts (1) from the track shoe (2) and remove shoe.

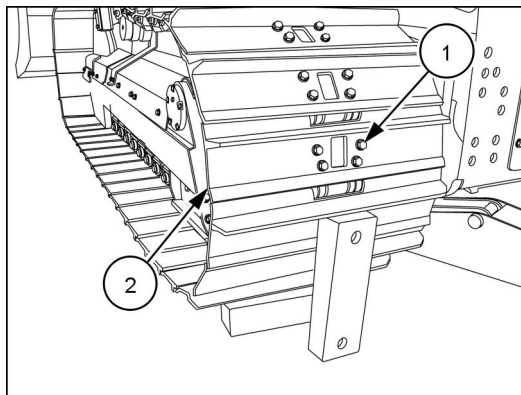

RAIL12DOZ0743BA 4

12. Separate master link with a pry bar.

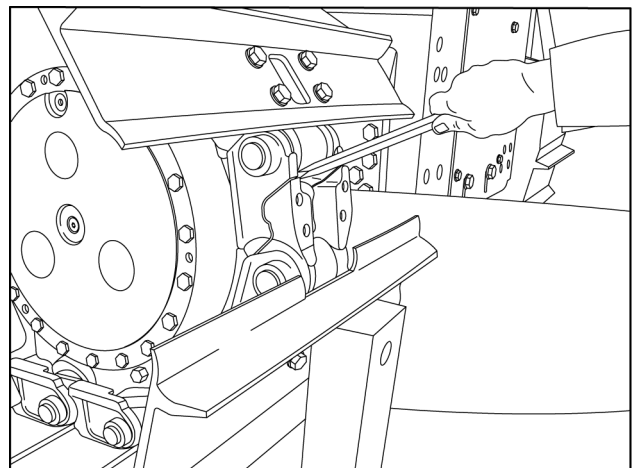

RAIL12DOZ0744BA 5

# Contents

---

## Cab climate control - 50

### Heating - 100

#### DIAGNOSTIC

##### Cab heater

Testing Optional ROPS Heater .....	3
------------------------------------	---

---

## Electrical system - Download – Programming the universal control module (UCM).

**NOTICE:** To properly download the correct software to the universal control module (UCM), use the following steps:

1. Connect the electronic service tool (EST) to the machine.
2. Turn the EST on, and select the correct model.
3. Click on the programming icon, and highlight “UCM Universal Control Module”.
4. Click on the SET UP CONTROLLERS FOR DOWNLOADING button.
5. When the small ELECTRONIC SERVICE TOOL window appears, set the parking brake, turn the ignition switch to the OFF position, and get out of the operator’s seat to allow the UCM to fully shut down. After the advanced instrument cluster (AIC) shuts down, wait for **5 s**, then sit down and turn the ignition switch back ON. When this is completed, click the OK button. (Clicking on the CANCEL button will abort programming.) Verify that the capture signal has appeared next to the highlighted “UCM Universal Control Module”:
6. Select the BROWSE button.
7. Highlight the file to move it into the FILE NAME box, and click the OPEN button.
8. When the DOWNLOAD FILE INFORMATION window opens, click the OK button.
9. When the PROGRAM DOWNLOAD button is highlighted, click on the PROGRAM DOWNLOAD button.
10. When the small ELECTRONIC SERVICE TOOL window appears, click the OK button.
11. The PROGRAMMING window opens when the downloading begins, and the status of the download process is shown.
12. When the download is complete, the small ELECTRONIC SERVICE TOOL window opens. Click the OK button.
13. Turn the ignition key to the OFF position, and get out of the operator’s seat to allow the UCM to fully shut down. After the advanced instrument cluster (AIC) shuts down, wait for **5 s**, then sit down and turn the ignition switch back ON.

# Contents

---

## Electrical systems - 55

### Service brake electrical system - 030

#### DIAGNOSTIC

Brake pressure sensor

Testing ..... 3

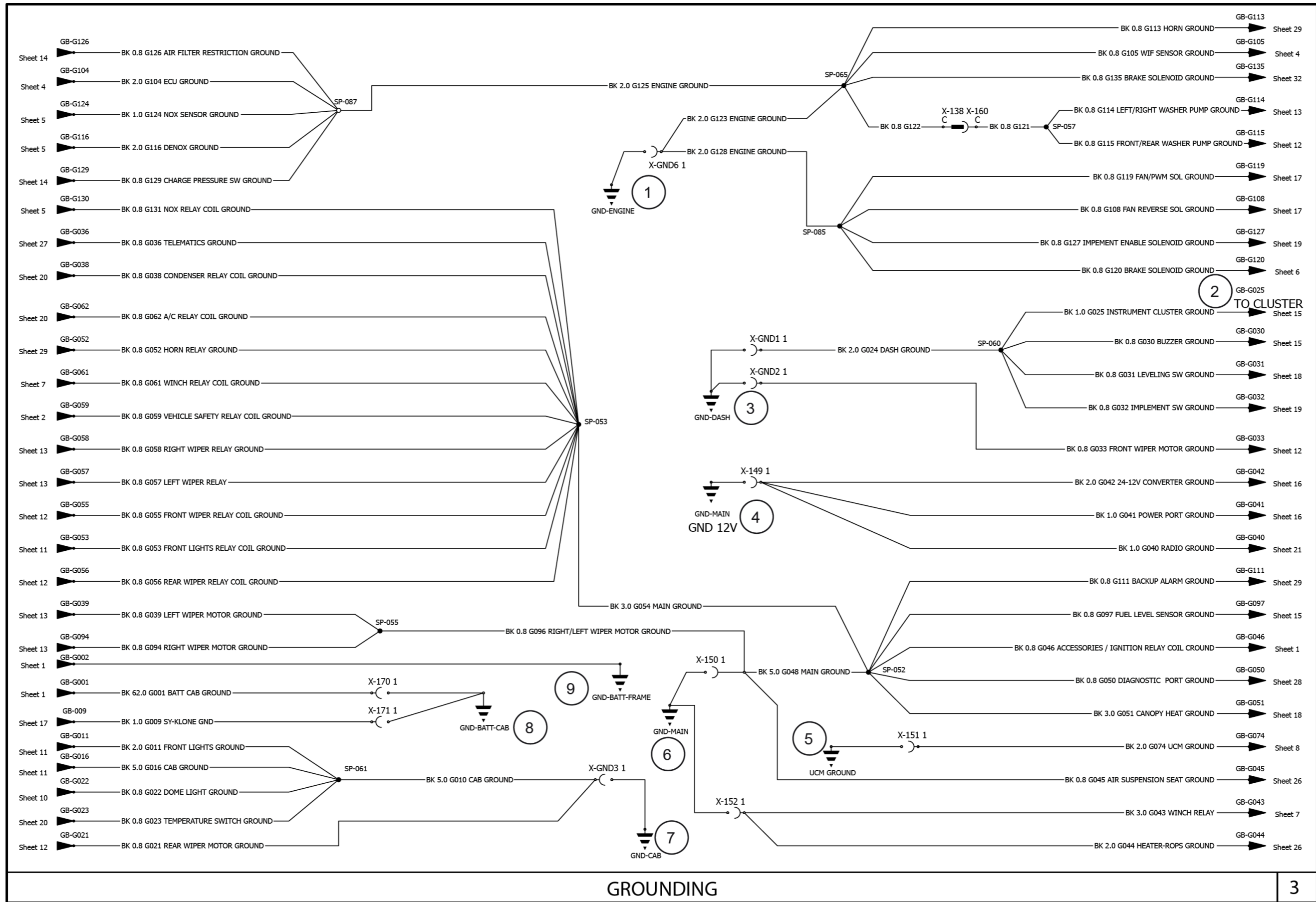

GROUNDING

---

**Harnesses and connectors - Electrical schematic sheet 12 Front/Rear  
Windshield Wipers**

Item	Description
1	Front/rear washer and washer
2	Ground
3	Front wiper relay
4	Front wiper motor
5	Rear wiper relay
6	Washer pump
7	Rear wiper motor

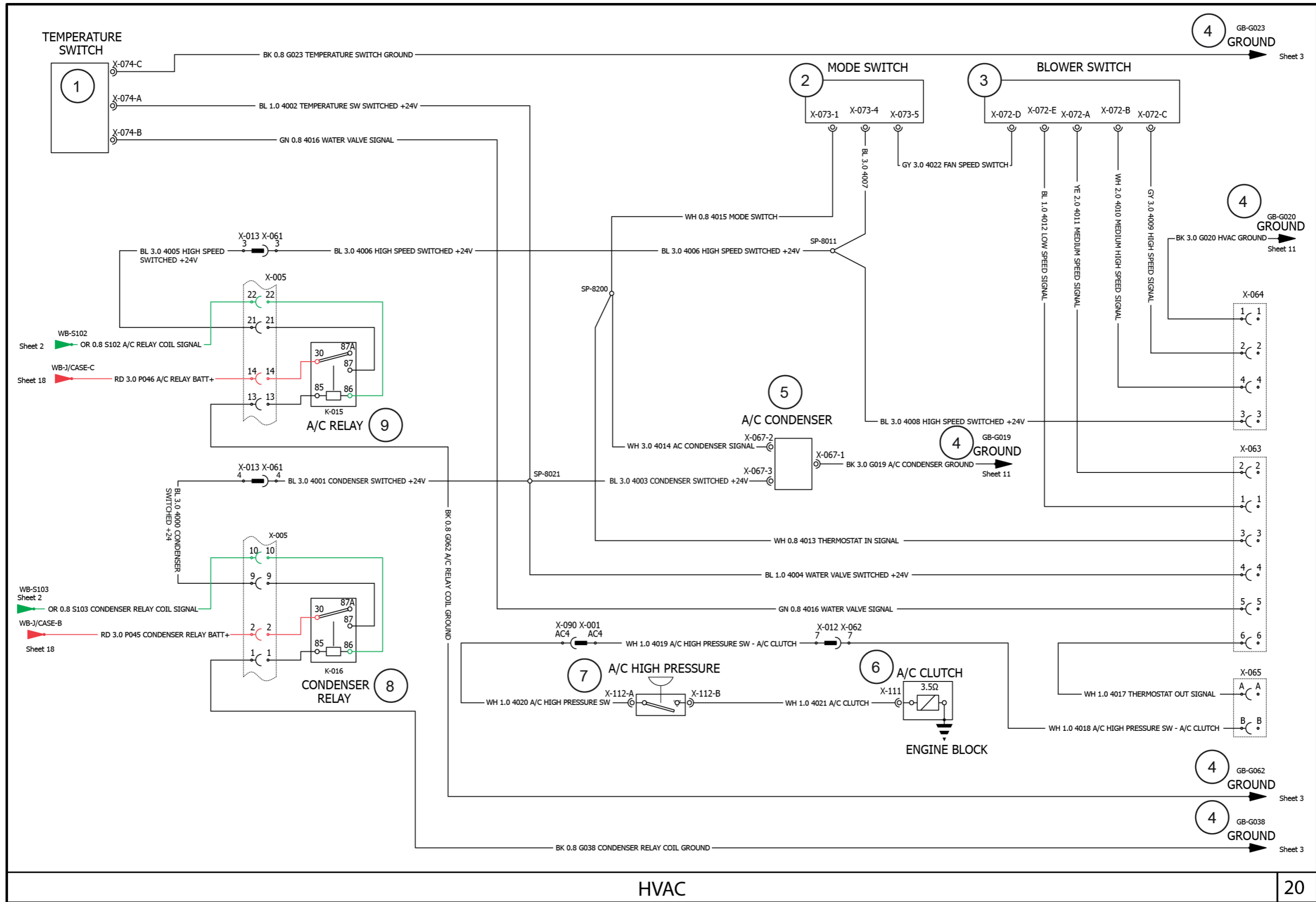

HVAC

---

## Harnesses and connectors - Electrical schematic sheet 29 Horn/Back Up Alarm

Item	Description
1	Horn
2	Horn Relay
3	Back Up Alarm

**CONNECTOR X-096 - RIPPER DOWN**

CONNECTOR X-096 - RIPPER DOWN			
PIN NUMBER	WIRE NUMBER	CIRCUIT REFERENCE	ELECTRICAL SCHEMATIC FRAME
1	L131 (WH)	X-096 RIPPER DOWN X-090 TO MAIN	
2	A222 (GY)	X-096 RIPPER DOWN SP-068	

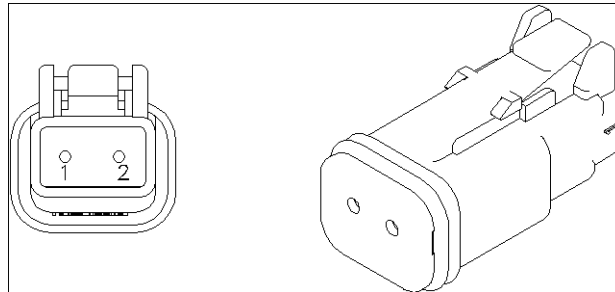

87695582 7

**CONNECTOR X-114 - REAR PUMP**

CONNECTOR X-114 - REAR PUMP			
PIN NUMBER	WIRE NUMBER	CIRCUIT REFERENCE	ELECTRICAL SCHEMATIC FRAME
1	C223 (GY)	X-114 REAR PUMP SP-079	
2	C251 (WH)	X-090 TO MAIN X-114 REAR PUMP	
3	C191 (WH)	X-090 TO MAIN X-114 REAR PUMP	
4	A213 (GY)	X-114 REAR PUMP SP-078	

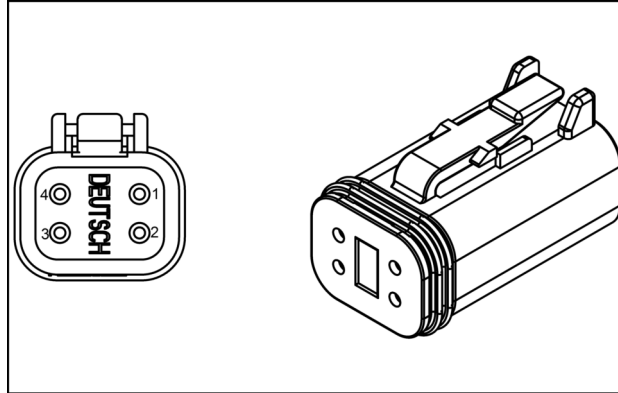

84122128 4

**CONNECTOR X-133 - RIGHT MOTOR**

CONNECTOR X-133 - RIGHT MOTOR			
PIN NUMBER	WIRE NUMBER	CIRCUIT REFERENCE	ELECTRICAL SCHEMATIC FRAME
1	H061 (WH)	X-090 TO MAIN X-133 RIGHT MOTOR	
2	C212 (GY)	X-133 RIGHT MOTOR SP-080	

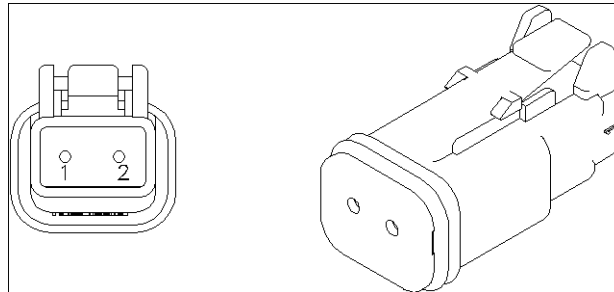

87695582 4

**CONNECTOR X-018 - UCM - CN3A**

CONNECTOR X-018 - UCM - CN3A			
PIN NUMBER	WIRE NUMBER	CIRCUIT REFERENCE	ELECTRICAL SCHEMATIC FRAME
5	H050 (YE)	WINCH HIGH SIDE DRIVE SIGNAL	
6	H060 (WH)	R MOTOR SIGNAL	
7	S068 (OR)	UCM MOTORS SWITCHED +24V	
11	H110 (WH)	L SPEED SENS DIR	
12	K120 (GN)	SEAT SW SIGNAL	
13	S069 (OR)	UCM MOTORS SWITCHED +24V	
16	H160 (WH)	R SPEED SENS DIR	
19	H190 (WH)	L MOTOR SIGNAL	
20	G081 (BL)	BLADE SENSOR GROUND 1	
26	G067 (BK)	UCM GROUND	

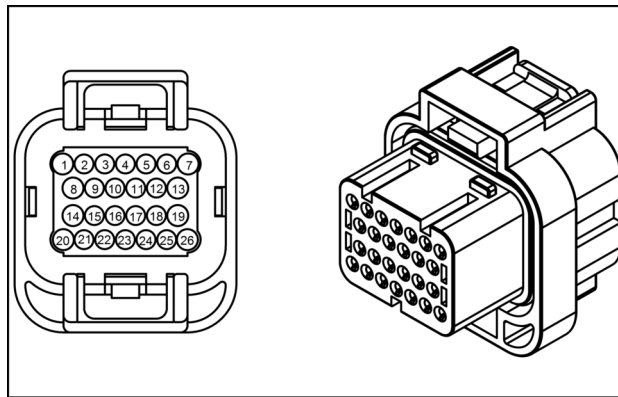

84130757 9

**CONNECTOR X-034 - X-034**

CONNECTOR X-034 - X-034			
PIN NUMBER	WIRE NUMBER	CIRCUIT REFERENCE	ELECTRICAL SCHEMATIC FRAME
A	-	-	
B	-	-	
C	-	-	
D	-	-	
E	-	-	
F	-	-	
G	-	-	
H	-	-	

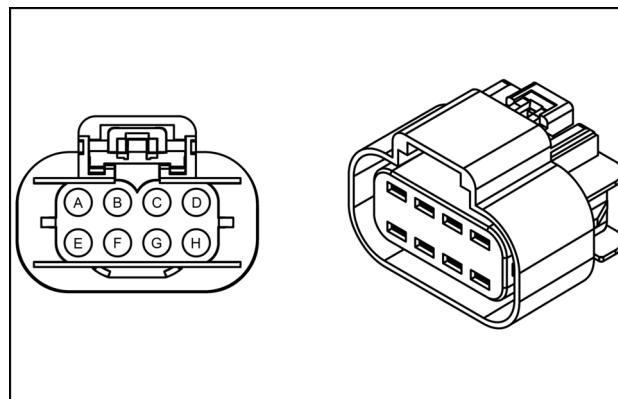

84137509 5

**CONNECTOR X-051 - REAR LIGHTS**

CONNECTOR X-051 - REAR LIGHTS			
PIN NUMBER	WIRE NUMBER	CIRCUIT REFERENCE	ELECTRICAL SCHEMATIC FRAME
1	-	-	
2	S015 (OR)	REAR LIGHTS SW SWITCHED +24V	
3	3011 (VT)	REAR LIGHTS SWITCHED +24V	
4	-	-	
5	-	-	
6	-	-	
7	-	-	
8	-	-	
9	-	-	
10	-	-	

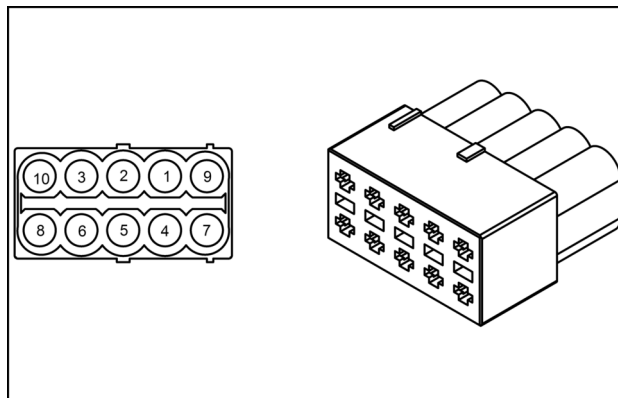

84159859 2

**CONNECTOR X-067 - CONDENSOR**

CONNECTOR X-067 - CONDENSOR			
PIN NUMBER	WIRE NUMBER	CIRCUIT REFERENCE	ELECTRICAL SCHEMATIC FRAME
1	G019 (BK)	A/C CONDENSER GROUND	
2	4014 (WH)	AC CONDENSER SIGNAL	
3	4003 (BL)	CONDENSER SWITCHED +24V	
4	-	-	

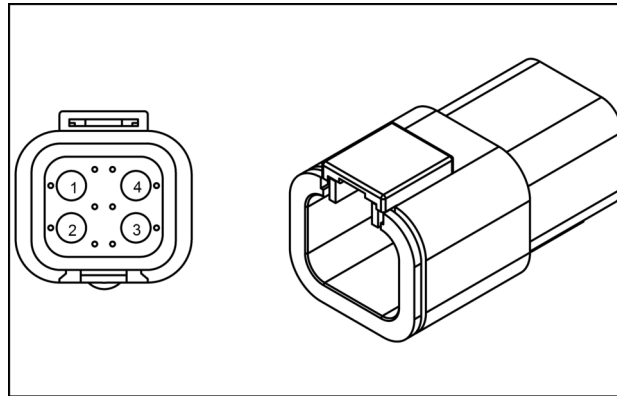

87421341 9

**CONNECTOR X-082 - LEFT SPEAKER**

CONNECTOR X-082 - LEFT SPEAKER			
PIN NUMBER	WIRE NUMBER	CIRCUIT REFERENCE	ELECTRICAL SCHEMATIC FRAME
1	LT-POS (RD)	LEFT SPEAKER +	
2	LT-NEG (BR)	LEFT SPEAKER -	

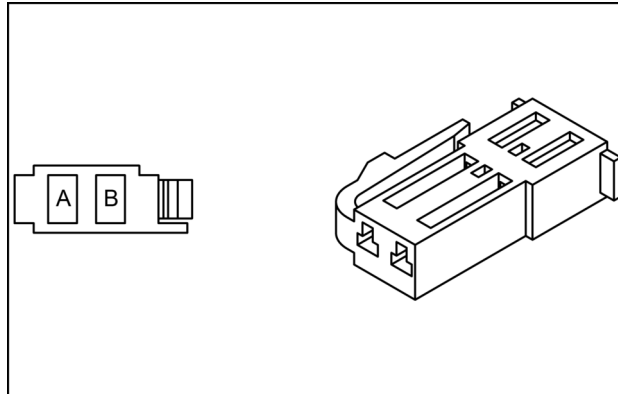

84147089 4

---

**CONNECTOR X-151 - UCM GND**

<b>CONNECTOR X-151 - UCM GND</b>			
<b>PIN NUMBER</b>	<b>WIRE NUMBER</b>	<b>CIRCUIT REFERENCE</b>	<b>ELECTRICAL SCHEMATIC FRAME</b>
1	G074 (BK)	UCM GROUND	

# Index

---

## Electrical systems - 55

### Engine starting system - 201

Engine start relay - Testing - Starter Relay .....	4
Engine start relay - Testing - Vehicle Safety Relay .....	4
Engine starting system - Testing - Engine will not crank .....	3

## Cab controls - Testing - Horn does not operate

N°	Test Point	Expected Result	Other Result (Possible Cause)
1	<p><b>Condition</b> Turn the ignition switch OFF.</p> <p><b>Check</b> Visually inspect the horn. Verify that the horn is not corroded or rusted. Verify that the horn is not packed with dirt or debris.</p>	<p><b>Result</b> The horn is free of corrosion, dirt and damage.</p>	<p><b>Action</b> The horn is full of dirt or the horn shows signs of corrosion and damage. Repair as required.</p>
2	<p><b>Condition</b> Turn the ignition switch OFF.</p> <p><b>Check</b> Verify the connections to the horn relay are tight and secure. Verify the connections to the horn are tight and secure. Check the wiring and connections for corrosion, abrasion and damage.</p>	<p><b>Result</b> The connections are secure. The connections are free of corrosion, abrasion and damage.</p>	<p><b>Action</b> The connections are not secure or the connections show signs of corrosion, abrasion and damage. Repair as required.</p>
3	<p><b>Condition</b> Turn the ignition switch OFF.</p> <p><b>Check</b> Remove the horn relay. Measure the resistance between the horn relay connector X-005 pin 25 and chassis ground. Measure the resistance between the horn relay X-005 pin 33 and horn connector X-130. Measure the resistance between horn connector X-131 and chassis ground.</p>	<p><b>Result</b> The resistance should be less than <b>10 Ω</b>.</p>	<p><b>Action</b> The resistance is greater than <b>10 Ω</b>, there is a problem with the signal wires from the horn relay. Repair as required.</p>
4	<p><b>Condition</b> Turn the ignition switch ON.</p> <p><b>Check</b> Measure the voltage between horn relay connector X-005 pin 26 and chassis ground.</p>	<p><b>Result</b> The voltage should be approximately <b>24 V</b>.</p>	<p><b>Action</b> The voltage is less than <b>18 V</b>. There is a problem with the unswitched battery supply to the relay. Check fuse F-015. Check splice SP-032. Check joystick connector X-036 pin 10. Repair as required.</p>
5	<p><b>Condition</b> Turn the ignition switch ON.</p> <p><b>Check</b> Press the horn button on the joystick. Measure the voltage between horn connector X-005 pin 34 and chassis ground.</p>	<p><b>Result</b> The voltage should be approximately <b>24 V</b>.</p>	<p><b>Action</b> The voltage is less than <b>18 V</b>. There is a problem with horn signal to the relay. Repair as required.</p>
6	<p><b>Condition</b> Turn the ignition switch OFF.</p> <p><b>Check</b> Disconnect horn connector X-130 and connector X-131. Measure the resistance across the horn.</p>	<p><b>Result</b> The resistance is greater than <b>1 Ω</b> but less than <b>3 Ω</b>. Temporarily replace the horn relay and retest.</p>	<p><b>Action</b> The resistance is less than <b>1 Ω</b> or greater than <b>3 Ω</b>. There is a problem with horn. Temporarily replace the horn and retest.</p>

## Cab controls - Testing - Radio does not operate

N°	Test Point	Expected Result	Other Result (Possible Cause)
1	<p><b>Condition</b> Turn the ignition switch OFF.</p> <p><b>Check</b> Verify the connections to the radio are tight and secure. Verify the connections to the speakers are tight and secure. Check the wiring and connections for corrosion, abrasion and damage.</p>	<p><b>Result</b> The connections are secure. The connections are free of corrosion, abrasion and damage.</p>	<p><b>Action</b> The connections are not secure or the connections show signs of corrosion, abrasion or damage. Repair as required.</p>

## Diesel Exhaust Fluid (DEF)/AdBlue® supply module - Remove - Filter element

1. Park the machine on a level ground. Lower the blade to the ground and turn the machine OFF.
2. Attach a vacuum to the **DEF/AdBlue®** system to eliminate the siphoning of the urea from the tank.
3. Remove the left rear exterior cover plate.
4. Locate the connector at the bottom of the **DEF/AdBlue®** filter.

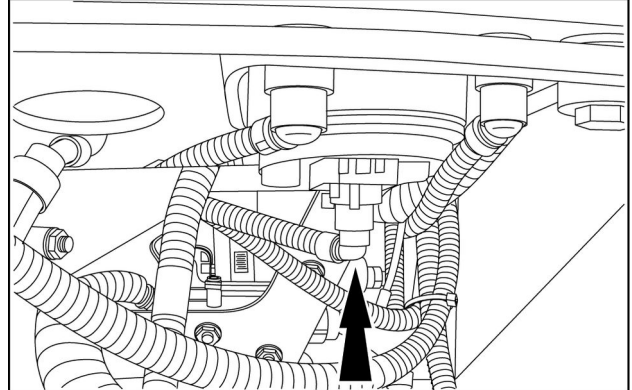

RAPH12DOZ0309AA 1

5. Disconnect the connector from the bottom of the main filter by first pushing the connector upward, then squeeze the locking tabs together and pull the connector down and off.

**NOTE:** O-rings might need to be lubricated for connector to disconnect. Squirt water between the connections to lubricate.

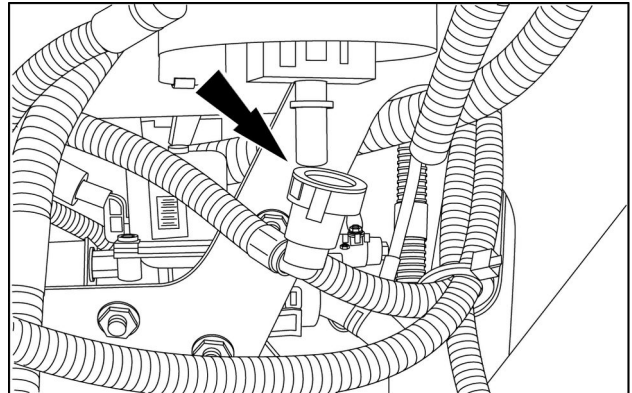

RAPH12DOZ0312AA 2

6. With the correct wrench, loosen the filter and then hand unscrew.

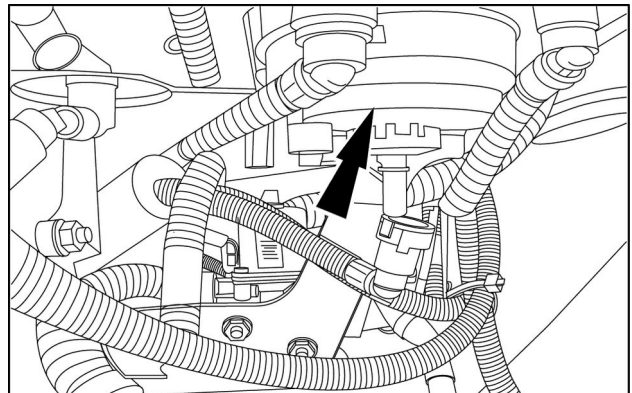

RAPH12DOZ0311AA 3

6. Open the right-hand side engine compartment side panel.

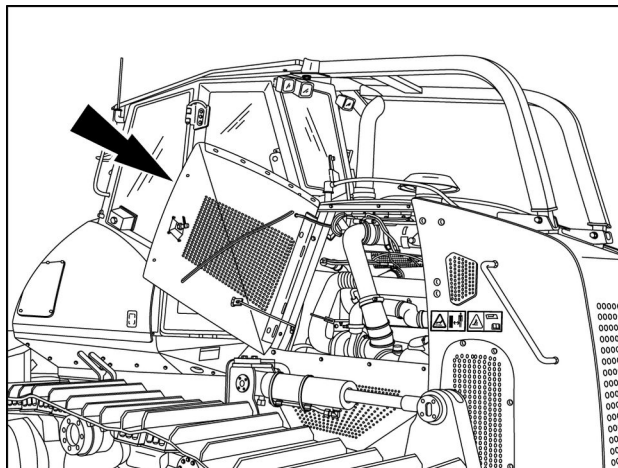

RAIL14DOZ0150AA 3

7. Locate the exhaust gas temperature (EGT) sensor that is installed into the exhaust system before the selective catalytic reduction (SCR) catalyst muffler.

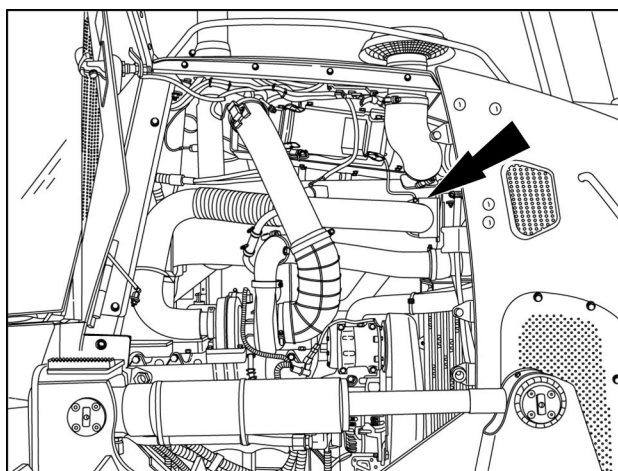

RAIL13DOZ1688AA 4

8. Remove the wire ties that secure the EGT sensor wire, and disconnect the EGT sensor wire from the machine wire harness.

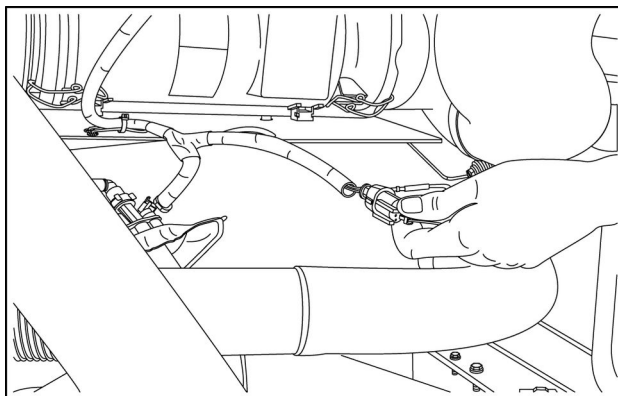

RAIL13DOZ0813AA 5

9. Remove the bolts and spacers that secure the air cleaner heat shield. Retain the mounting hardware.

**NOTE:** Do not lose the metal spacers from between the heat shield and the air filter housing.

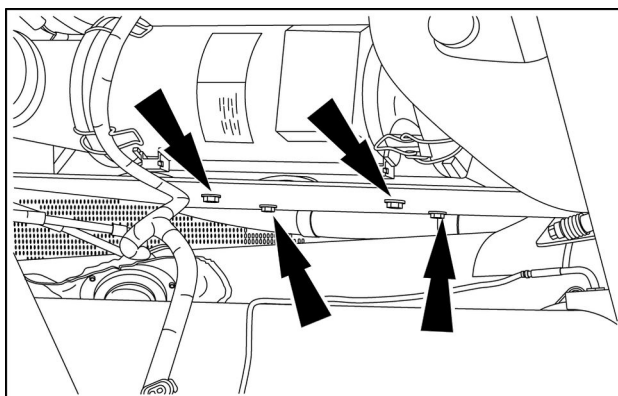

RAIL13DOZ0817AA 6

# Contents

---

## Electrical systems - 55

### FAULT CODES - DTC

#### DIAGNOSTIC

1001-Seat Switch: Open Circuit or Short to Ground .....	14
1003-Seat Switch: Short to Power .....	18
1005-Seat Switch: Plausibility Error .....	21
1101-Throttle Sensor: Signal Short to Ground .....	24
1103-Throttle Sensor: Signal Short to Power .....	27
1111-Decel Pedal Sensor: Signal Short to Ground .....	29
1113-Decel Pedal Sensor: Signal Short to Power .....	31
1201-Backup Alarm Open Circuit .....	33
1202-Backup Alarm Shorted to Ground .....	35
1203-Backup Alarm Shorted to Power .....	37
1301-Left Speed Sensor Frequency Input Shorted to Ground or Open Circuit .....	39
1311-Right Speed Sensor Frequency Input Shorted to Ground or Open Circuit .....	42
1321-Left Speed Sensor Direction Input Shorted to Ground or Open Circuit .....	45
1323-Left Speed Sensor Direction Input Shorted to Power .....	48
1341-Right Speed Sensor Direction Input Shorted to Ground or Open Circuit .....	50
1343-Right Speed Sensor Direction Input Shorted to Power .....	53
1400-UCM Supply Voltage Below Operational Limit .....	55
1408-UCM Supply Voltage Lower Than Normal .....	57
1409-UCM Supply Voltage Higher Than Normal .....	59
1416-5VREF1 Sensor Supply Voltage (For seat switch) Out of Range .....	61
1426-5VREF2 Sensor Supply Voltage (Decel pedal, drive joystick, blade joystick, aux joystick) Out of Range .....	63
1436-5VREF3 Sensor Supply Voltage (Hand throttle, drive joystick, blade joystick, aux joystick) Out of Range .....	66
1448-24VF4 - Blade Tilt and Angle Supply Voltage Lower Than Normal .....	69
1458-24VF2 - Ripper and Blade Lift Supply Voltage Lower Than Normal .....	71
1468-24VF3 - Pump Supply Voltage Lower Than Normal .....	73
1478-24VF6 - Motors Supply Voltage Lower Than Normal .....	75
1488-24VS1 - Digital Outputs Supply Voltage Lower Than Normal .....	77
1490-5V Regulators Supply (24VB rail) Lower Than Normal .....	79
1508-LED Drives Supply Voltage Lower Than Normal .....	81
1516-UCM Ground Fault .....	83

Schematic legend			
(1)	<b>UCM connector X-014</b> Pin 3	(3)	Seat switch
(2)	<b>Connector X-023</b>	(4)	<b>UCM connector X-018</b> Pin 12

A. The connectors are secure and the harness is free of damage. Go to step 3.

B. The connectors or the harness has damage. Repair or replace the harness or connectors as required. Return to step 1 to confirm elimination of fault.

3. Test the seat switch circuit.

Turn the ignition switch OFF.

Disconnect seat connector X-023.

Fabricate a jumper wire that will connect between **X-023** pin 5 and **X-023** pin 6.

Connect the jumper wire between **X-023** pin 5 and **X-023** pin 6.

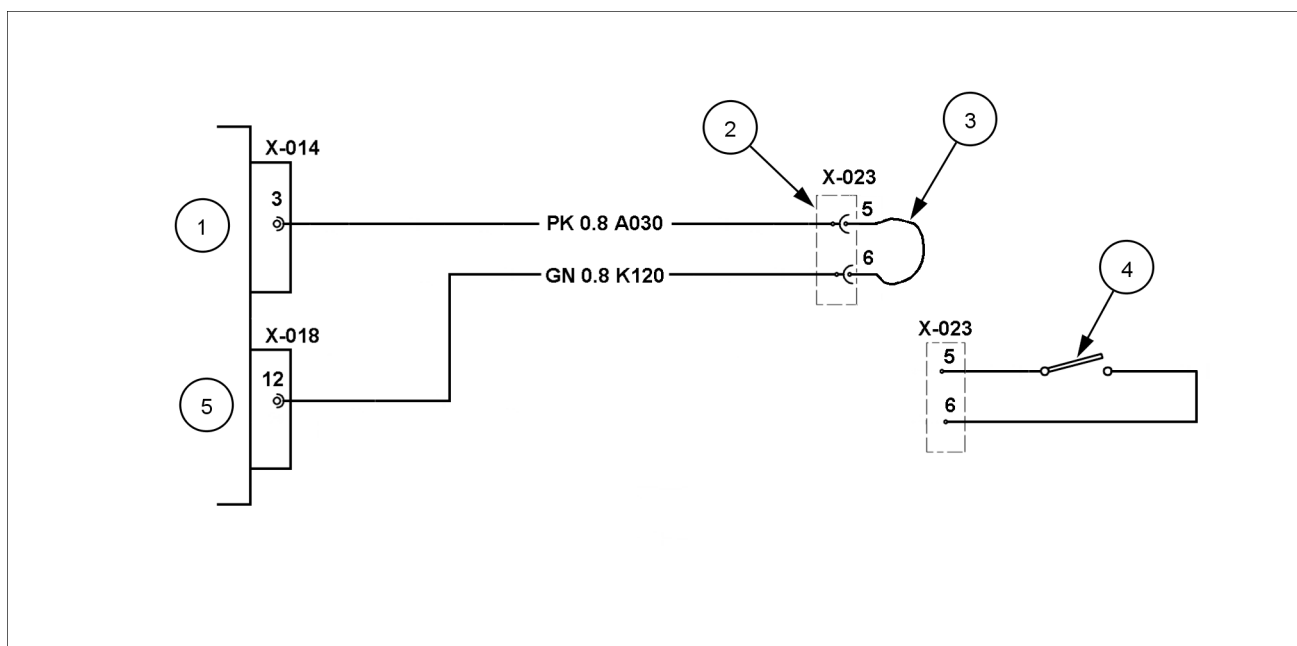

RAIL12DOZ0155FA 2

Schematic legend			
(1)	<b>UCM connector X-014</b> Pin 3	(4)	Seat switch
(2)	<b>Connector X-023</b>	(5)	<b>UCM connector X-018</b> Pin 12
(3)	Jumper wire connected between <b>X-023</b> pin 5 and pin 6		

Turn the ignition switch ON.

Access the fault code screen on the electronic service tool. Fault code 1003 should no longer be active.

A. Fault code 1003 is active. Go to step 4.

B. Fault code 1003 is no longer active. There is a problem in the wiring between **X-023** and the seat switch. Repair or replace the wiring harness as required. Return to step 1 to confirm elimination of the fault.

4. Measure the resistance to other circuits.

Turn the ignition switch OFF.

A. The connectors are secure and the harness is free of damage. Go to step 3.

B. The connectors or the harness has damage. Repair or replace the harness or connectors as required. Return to step 1 to confirm elimination of fault.

3. Test the circuit.

Turn the ignition switch OFF.

Disconnect the backup alarm.

Set the park brake to ON.

Turn the ignition switch ON.

Move the transmission joystick into reverse.

Access the fault code screen on the EST. Fault code 1202 should no longer be active. Fault code 1201 is now active.

A. Fault code 1202 is no longer active. Fault code 1201 is now active. Temporarily replace the backup alarm and retest. Return to step 1 to confirm elimination of the fault.

B. Fault code 1202 is still present and active. Fault code 1201 did not become active. Go to step 4.

4. Measure the resistance of the signal wire to chassis ground.

Turn the ignition switch OFF.

Disconnect **UCM** connector **X-019**.

Measure the resistance between **X-019** pin 10 and chassis ground. The chassis ground connection must be clean and free of paint, oil, and dirt. The resistance should be greater than **20,000 Ω**. Wiggle the harness during measurement to reveal an intermittent condition.

A. The resistance is greater than **20,000 Ω**. Temporarily replace the **UCM** and retest. Return to step 1 to confirm elimination of the fault.

B. The resistance is less than **20,000 Ω**, there is a short circuit in the **UCM** wiring to chassis ground. Repair or replace the harness as required. Return to step 1 to confirm elimination of fault.

**Harnesses and connectors - Electrical schematic sheet 08 (55.100-C.20.E.08)**

**Harnesses and connectors - Electrical schematic sheet 29 (55.100-C.20.E.29)**

## 1343-Right Speed Sensor Direction Input Shorted to Power

**Context:**

The UCM detects a short circuit to another voltage source in the right speed sensor direction input, **X-018** pin 16.

**Cause:**

There is a short circuit to another voltage source in the right speed sensor direction input, **X-018** pin 16.

**Possible failure modes:**

1. A short circuit in the right speed sensor direction wiring.
2. Faulty right speed sensor.
3. Faulty UCM.

**Solution:**

1. Verify that the fault code is active.

Connect the Electronic Service Tool to the service tool connector.

To check for fault codes: Start and operate the machine.

- A. The fault code is not recorded again. OK to return the machine to service.
- B. Fault code 1343 is recorded again. Go to step 2.

2. Verify that the wiring and connectors are free of damage.

Inspect the **UCM** and the right speed sensor connections. All connections should be secure, tight, free of corrosion, abrasion and damage.

Inspect the harness from the **UCM** to the right speed sensor. Verify that the harness is free of damage, corrosion, abrasion and incorrect attachment.

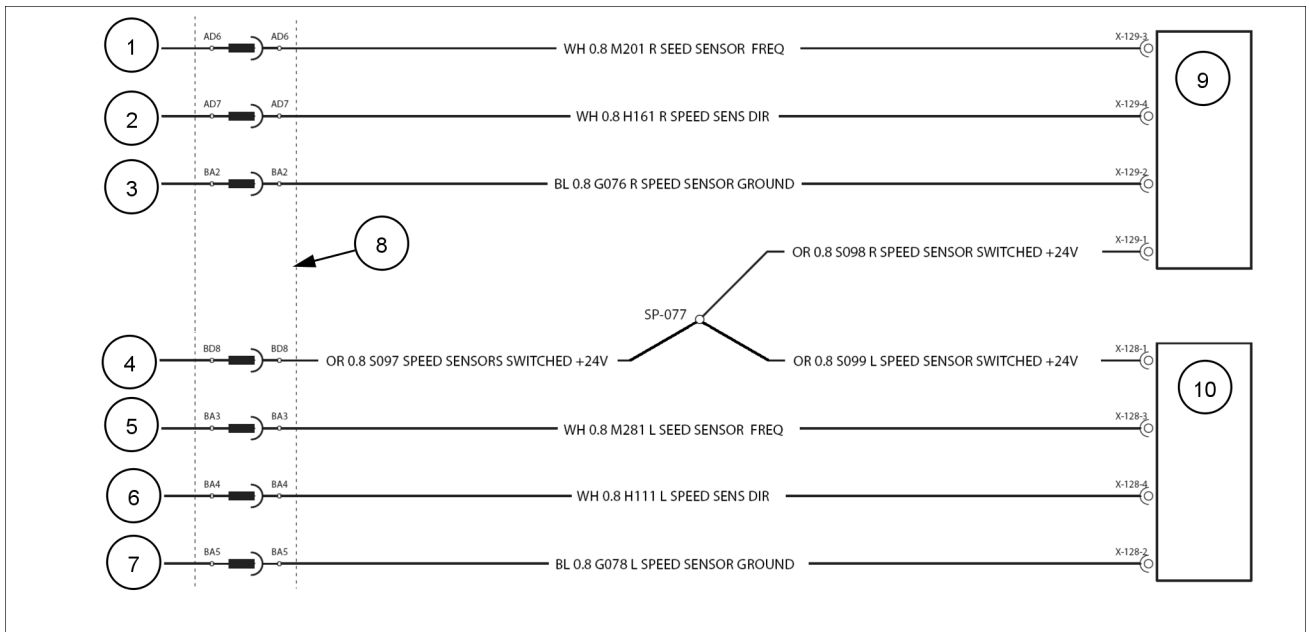

RAIL12DOZ0432FA 1

Schematic legend			
(1)	<b>UCM connector X-020</b> Pin 20, Right speed sensor frequency	(6)	<b>UCM connector X-018</b> Pin 11, Left speed sensor direction
(2)	<b>UCM connector X-018</b> Pin 16, Right speed sensor direction	(7)	<b>UCM connector X-020</b> Pin 34, Left speed sensor ground

CLICK HERE TO **DOWNLOAD** THE COMPLETE MANUAL

- Thank you very much for reading the preview of the manual.
- You can download the complete manual from: [www.heydownloads.com](http://www.heydownloads.com) by clicking the link below



- Please note: If there is no response to CLICKING the link, please download this PDF first and then click on it.

CLICK HERE TO **DOWNLOAD** THE COMPLETE MANUAL

Schematic legend			
(1)	24 V battery supply to fuse <b>F-022</b>	(2)	<b>UCM</b> connector <b>X-019</b> Pin 8 and pin 9

A. The connectors are secure and the harness is free of damage. Go to step **3**.

B. The connectors or the harness has damage. Repair or replace the harness or connectors as required. Return to step **1** to confirm elimination of fault.

3. Measure the voltage at the UCM connector.

Turn the ignition switch OFF.

Disconnect UCM connector **X-019**.

Turn the ignition switch ON.

Measure the voltage between **X-019** pin 8 and chassis ground. The chassis ground must clean and free of paint, oil and dirt. The voltage should be approximately **24 V**. Wiggle the harness during measurement to reveal an intermittent condition.

Measure the voltage between **X-019** pin 9 and chassis ground. The chassis ground must clean and free of paint, oil and dirt. The voltage should be approximately **24 V**. Wiggle the harness during measurement to reveal an intermittent condition.

A. Both voltage measurements are greater than **20 V**. There is a problem in the **UCM**. Temporarily replace the **UCM** and retest. Return to step **1** to confirm elimination of the fault.

B. The voltage is less than **20 V**. There is a problem in the wiring to the **UCM**. Check fuse **F-022**. Repair as required. Return to step **1** to confirm elimination of the fault.

**Harnesses and connectors - Electrical schematic sheet 08 (55.100-C.20.E.08)**

## 1809-UCM Temperature / Current Draw Over Limit

### Context:

The combined UCM current is greater than a predefined limit or the UCM temperature is greater than normal.

### Cause:

The combined UCM current is greater than a predefined limit or the UCM temperature is greater than normal. This fault code may be active with fault code 1829 and other fault codes such as high engine temperatures or low battery voltages.

### Possible failure modes:

1. A problem in the voltage supply to the UCM.
2. High engine temperatures.
3. Faulty UCM.

### Solution:

1. Verify that the fault code is active.

Connect the Electronic Service Tool to the service tool connector.

To check for fault codes: Start and operate the machine.

- A. The fault code is not recorded again. OK to return the machine to service.
  - B. Fault code 1809 is recorded again along with other codes such as fault code 3007 high coolant temperature or fault code 1408 low battery voltage troubleshoot these codes first.
  - C. Fault code 1809 is recorded again. No other codes are present. Go to step **2**.
2. Verify that the wiring and connectors are free of damage.

Turn the ignition switch OFF.

Verify the minus battery connections from the battery to the frame are tight and secure.

Verify the connections from the battery to the **UCM** are tight and secure.

Verify the harness is free of damage, abrasion, corrosion, and incorrect attachment from the battery to the **UCM**.

## 19046-Reagent - pressure sensor - Open circuit

### Context:

The Dosing Control Unit (DCU) has detected a DEF/AdBlue® pressure sensor failure. This pressure sensor is located inside the DCU.

### Cause:

This fault occurs when the sensor signal level is below **0.1 V** for over **700 ms**. This fault is corrected if sensor returns to normal output for greater than **1.0 s**.

### Possible failure modes:

1. A faulty DEF/AdBlue® supply line.
2. Faulty DCU wiring.
3. A faulty DCU.

### Solution:

1. Verify the fault is still present and in an active state.
  - A. If the fault is still present and active, continue with step **2**.
  - B. If the fault is not present, the fault may be intermittent. Check for an intermittent the fault. If no the faults are found, clear the fault code. Return machine to service.
2. Visually inspect the DEF/AdBlue® lines.
  - A. If there is no damage, continue with step**3**.
  - B. Repair/replace damaged lines.
3. Visually inspect for a damaged DCU wiring, harness, pins or connectors.
  - A. If there is no damage, continue with step**4**.
  - B. Repair/replace damaged wiring.
4. Verify the proper software level is installed in the DCU.
  - A. The incorrect software level is installed. Install the correct software level. Test the system for proper operation.
  - B. The correct software level is installed, replace the DCU. Install the current software level. Test the system to verify repairs.

**NOTE:** *If the unit is equipped with 2010 or 2011 software, you can update the software to 2012. If you update the Engine Control Unit (ECU) software, the Display software also needs to be updated. This will change how the operator observes and detects the faults with the after treatment system. Be advised, if you update software to a newer level you cannot reverse back to the older software.*

**Harnesses and connectors - Electrical schematic sheet 05 (55.100-C.20.E.05)**

---

## 19101-Reagent - tank level sensor - Short circuit high

**Context:**

The Dosing Control Unit has sensed the level of AdBlue™/Def drops below a predetermined level. If the signal is higher than **4.7 V** for **0.5 s**.

**Cause:**

There is an open circuit in the AdBlue™/Def Heated level sensor circuit.

**Possible failure modes:**

1. Faulty Sensor.
2. Faulty electrical wiring or connection.
3. Faulty DCU.

**Solution:**

1. Verify this error code is still present, and in an active state.
  - A. If the error is still present and active, continue with step **2**.
  - B. If the error is no longer present or is in an inactive state, continue with step **5**.
2. Disconnect the wiring harness from the AdBlue™/Def Heated level sensor. Measure the resistance on the sensor from pin 3 to pin 2. There should be approximately **2.5k Ω**.
  - A. If the resistance is within range, continue with step **3**.
  - B. If the resistance is infinite or **0.0 Ω** the sensor has failed. Replace the sensor.
3. Disconnect the wiring harness from the AdBlue™/Def Heated level sensor. Measure the resistance of the level sensor from pin 1 to pin 2. There should be approximately **232 - 252 Ω** when the tank is empty, and **28 - 36 Ω** when the tank is full.
  - A. If the resistance is within range, continue with step **4**.
  - B. If the resistance is infinite or **0.0 Ω** the sensor has failed. Replace the sensor.
4. Disconnect the wiring harness from the DCU. Test the wiring harness from the harness side of the sensor connector to the DCU harness side of the connector. Refer to product service manual for testing procedure.
  - A. If wiring harness test is good, the DCU has failed. Replace the DCU.
  - B. If the wiring harness test fails, find and replace faulty wiring.
5. Visually inspect the relevant harnesses and connectors for damage, bent or dislocated pins, corroded terminals or broken wires. Verify that the connectors are fully installed. Flex the harnesses involved to reveal intermittent breaks or shorts in the wiring concerned. Operate the machine while monitoring the Display.
  - A. If damage is found or other than normal display readings are indicated, repair the damage discovered during the inspection or locate and repair the other than normal display condition and verify that the error has been resolved.
  - B. If no damage or other than normal display readings are indicated, erase the fault code and continue operation.

**Harnesses and connectors - Electrical schematic sheet 05 (55.100-C.20.E.05)**

## **19164-Vent valve (Cooling Purge Control Valve) - Open circuit**

**Context:**

The dosing control unit (DCU) has detected a failure of the SCR Coolant control valve. If this error is detected, there is a short internal to the pump module. Ensure all connectors are secured properly on the DCU and all lines are in operable condition. If fault does not reset or reoccurs, replace the DCU.

**Harnesses and connectors - Electrical schematic sheet 05 (55.100-C.20.E.05)**

---

## 19578-CAN Receive Frame E2SCR (Dosing Status Not In Range)

### Possible failure modes:

1. Controller communication error.

### Solution:

1. Check for other error codes being displayed. Are there other codes displayed referring to dosing valve solenoid. Are there other can bus communication error issues.
  - A. If any other error code is being displayed, continue to these tests.
  - B. If no other error code is displayed, continue to step 2
2. Ensure all connectors are secured properly on the denox module/supply module connector, the denox terminator connector (located on top of right front fender) and engine control module connector. Check for damage, loose connections or broken can bus wires.
  - A. A connector/wiring issue was located and corrected. Erase fault code and return unit to field operation.
  - B. No connector/wiring issues were located. Continue with step 3.
3. Check the can bus terminators. Disconnect denox terminator connector . Check the terminators resistance from pin 1 to pin 2. The expected reading is **120 Ω**.
  - A. Expected reading is not found. Replace denox terminator. Erase fault code and return unit to field operation.
  - B. Reading is as expected. Continue with step 4.
4. Next, check the harness end resistance on connector from pin 1 to pin 2. This will be checking the engine control modules internal terminator. The expected reading is **120 Ω**.
  - A. Expected reading not found. There may be a short to ground, or open wire between the denox terminator and engine control module connector, or the engine control module terminator is faulty. Troubleshoot the wiring harness make repairs, or replace engine control module.
  - B. Reading is as expected. Erase fault code. If the fault code reoccurs contact ASIST.

**Harnesses and connectors - Electrical schematic sheet 28 (55.100-C.20.E.28)**

## 19651-Tank Level Sensor - Short Circuit Low

### Context:

The Dosing Control Unit (DCU) has sensed the level of DEF/AdBlue® has dropped below a predetermined level. If the signal is lower than **0.2 V** for **0.5 s** this fault will occur.

### Cause:

There is an short circuit in the DEF/AdBlue® heated tank temperature/level sensor circuit.

### Possible failure modes:

1. A faulty DEF/AdBlue® heated tank temperature/level sensor.
2. A faulty wiring harness or connection.
3. A faulty DCU.

### Solution:

1. Verify this fault code is still present, and in an active state.
  - A. If the fault is still present and active, continue with step **2**.
  - B. If the fault is no longer present or is in an inactive state, continue with step **5**.
2. Disconnect the wiring harness from the DEF/AdBlue® heated tank temperature/level sensor. Measure the resistance on the sensor from pin 3 to pin 2. There should be approximately

Temperature	Resistance (Approximately)
-55 °C (-67.0 °F)	59975 Ω
-50 °C (-58.0 °F)	43010 Ω
-45 °C (-49.0 °F)	31243 Ω
-40 °C (-40.0 °F)	22973 Ω
-35 °C (-31.0 °F)	17088 Ω
-30 °C (-22.0 °F)	12850 Ω
-25 °C (-13.0 °F)	9764 Ω
-20 °C (-4.0 °F)	7492 Ω
-15 °C (5.0 °F)	5803 Ω
-10 °C (14.0 °F)	4534 Ω
-5 °C (23.0 °F)	3573 Ω
0 °C (32.0 °F)	2838 Ω
5 °C (41.0 °F)	2272 Ω
10 °C (50.0 °F)	1832 Ω
15 °C (59.0 °F)	1487 Ω
20 °C (68.0 °F)	1215 Ω
25 °C (77.0 °F)	1000 Ω
30 °C (86.0 °F)	827 Ω
35 °C (95.0 °F)	688 Ω
40 °C (104.0 °F)	576 Ω
45 °C (113.0 °F)	484 Ω
50 °C (122.0 °F)	409 Ω
55 °C (131.0 °F)	347 Ω
60 °C (140.0 °F)	295 Ω
65 °C (149.0 °F)	252 Ω
70 °C (158.0 °F)	216 Ω
75 °C (167.0 °F)	186 Ω
80 °C (176.0 °F)	160 Ω
85 °C (185.0 °F)	139 Ω

## 19757-Reagent Pump Not Delivering

**Context:**

The dosing control unit (DCU) has activated this fault due to other fault codes associated with the DEF / AdBlue® injection control being active being active. Diagnose those fault codes to clear this fault. If this fault is active without any other codes active, reload the software in the DCU or replace the DCU.

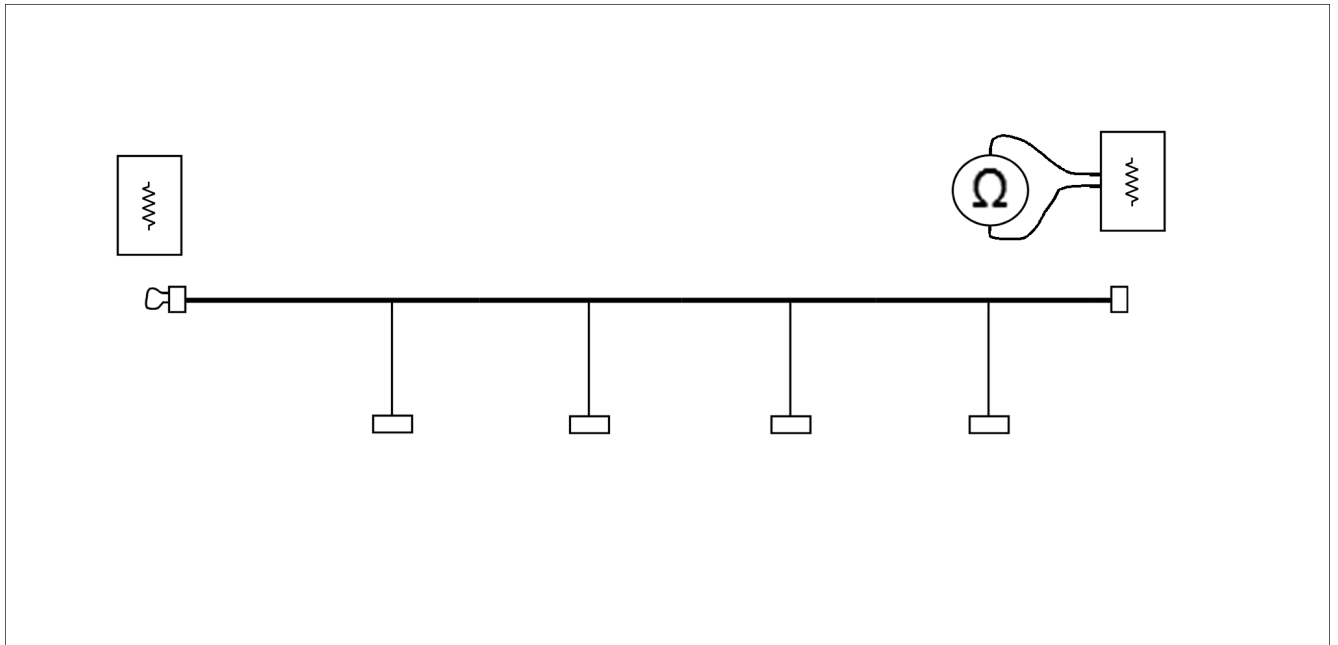

RAIL12DOZ0152FA 2

Measure the resistance directly on the instrument cluster CAN Bus pins. Measure the resistance between **X-058** pin 4 and pin 3. The resistance should be between **108 Ω** and **132 Ω**.

A. Both resistance measurements are approximately **120 Ω**. Return to step **6**.

B. One or more resistance measurements are greater than **140 Ω**. There is an open circuit in the CAN bus within the control. Replace the control module. Return to step **1** to confirm elimination of the fault.

**Harnesses and connectors - Electrical schematic sheet 28 (55.100-C.20.E.28)**

Turn the ignition switch OFF.

Disconnect the air intake temperature sensor from the harness.

Turn the ignition switch ON.

Use a multimeter to perform the following test. Wiggle the harness during measurement to reveal an intermittent condition.

	From	To	Result
Voltage measurement	Air intake (boost) temperature sensor power pin 3	Air intake (boost) temperature sensor ground pin 1	The voltage should be approximately <b>5 V</b>

A. The voltage measurement is between **4.5 V** and **5.5 V**. Go to step **5**.

B. The voltage is less than **4.5 V** or greater than **5.5 V**. There is a problem with the sensor supply voltage. Repair as required. Return to step **1** to confirm elimination of the fault.

5. Measure the resistance through the signal wires.

Turn the ignition switch OFF.

Disconnect the **ECU** sensor connector.

Fabricate a jumper wire that will connect between **ECU** sensor connector pin 34 and **ECU** sensor connector pin 36.

Connect the jumper wire between **ECU** sensor connector pin 34 and **ECU** sensor connector pin 36.

Use a multimeter to perform the following test. Wiggle the harness during measurement to reveal an intermittent condition.

	From	To	Result
Resistance measurement	Air intake temperature sensor pin 2 Air intake temperature signal	Air intake temperature sensor pin 4 Boost pressure signal	The resistance should be less than <b>10 Ω</b>

A. The resistance measurement is less than **10 Ω**. Go to step **5**.

B. The resistance measurement is greater than **10 Ω**. There is an open circuit in the wiring to the air intake temperature sensor. Repair as required. Return to step **1** to confirm elimination of the fault.

6. Measure the resistance of the signal wire to chassis ground.

Turn the ignition switch OFF.

Disconnect the **ECU** sensor connector.

Disconnect the air intake temperature sensor.

Use a multimeter to perform the following test. Wiggle the harness during measurement to reveal an intermittent condition.

	From	To	Result
Resistance measurement	Air intake temperature sensor pin 4	Chassis ground	The resistance should be greater than <b>20,000 Ω</b>
Resistance measurement	Air intake temperature sensor pin 2	Chassis ground	The resistance should be greater than <b>20,000 Ω</b>

A. Both resistance measurements are greater than **20,000 Ω**. Temporarily replace the **ECU** and retest. Return to step **1** to confirm elimination of the fault.

---

## 3024-Atmospheric Pressure Sensor - Signal Above Range Maximum

### Context:

The engine control unit (ECU) has detected a failure of the atmospheric pressure sensor, located inside the ECU. The sensor signal level is above **4.7 V** for over **800 ms**. This fault will reset if the raw signal level goes below **4.7 V** for over **480 ms**. In the case of a defective atmospheric pressure sensor, the atmospheric pressure value is set to a default value of **70 kPa (10.2 psi)**.

### Possible failure modes:

1. Faulty **ECU**.

### Solution:

1. Verify that the fault code is active.

Connect the Electronic Service Tool to the service tool connector.

To check for fault codes: Turn the ignition switch ON, engine OFF.

A. Fault code 3024 is not recorded again. Operate the machine under load to allow the system to warm up. If the fault code does not become active, return the machine to service.

B. Fault code 3024 is recorded again. Go to step 2.

2. Verify atmospheric pressure on the Electronic Service Tool.

Turn the ignition switch ON, engine OFF.

Access the Electronic Service Tool and monitor atmospheric pressure. The atmospheric pressure should be approximately **101.4 kPa (14.7 psi)**

A. The atmospheric pressure is less than **89 kPa (13 psi)** or greater than **110 kPa (16 psi)**. Temporarily replace the ECU and retest. Return to step 1 to confirm elimination of the fault.

It is not necessary to replace the ECU if the machine is not running in high altitudes or if a variable geometry turbocharger (VGT) is not installed on the engine.

Test Type	From	To	Expected Results
1. Voltage	1 (Pin 2, 3, 8, 9, 40)	Ground (engine block)	Approx. <b>12 volts</b>
2. Continuity	1 (Pin 5, 6, 10, 11)	Ground (engine block)	Approx. <b>0 - 0.10 ohms</b>

- A. If the voltages and ground paths are correct and the Oil temp / press sensor was not replaced on a prior diagnostic of this type, replace the sensor.
- B. If the voltages and ground paths are correct and the Oil temp / press sensor was replaced on a prior diagnostic of this type, re-initialize the ECU as if it was blank (new) and load the appropriate data-set.
- C. If the voltages and ground paths are correct and the ECU was re-initialized on a prior diagnostic of this type, replace the ECU.
- D. If the voltages and ground paths are not correct, refer to schematic and determine root cause of power or continuity problem(s).

**Harnesses and connectors - Electrical schematic sheet 04 (55.100-C.20.E.04)**

Vehicle Status: Key Off Engine Off.

Remove ECU connector 3 and perform an injector resistance test. Use the spade style test leads from the from the Tier II (NEF) Diagnostic Repair Kit #380040185 when probing the ECU harness side of connector 3. Make sure that the multi-meter's test lead resistance is taken into account when resistance measurements are taken. Record the multi-meter's test lead resistance by touching the leads together on the lowest Ohms scale and mentally recording the resistance value. Subtract this value from the actual resistance measurement taken. See test table below.

Test Type	From	To	Expected Results
1. Resistance	ECU harness connector 3 pin: 4	ECU harness connector 3 pin: 13	Approx. <b>0.4 - 0.5 ohms</b>

A. If resistance test was not successful, repair wiring harness between ECU harness connector 3 and connector VC1.

B. If resistance test was successful, proceed to step 5.

4. Operation: Standalone Injector Resistance Test.

Vehicle Status: Key Off Engine Off.

Remove valve cover from the top of the head to allow access to the internal injector wiring harness. Remove the Cylinder #1 injector connector (two flying leads with ring terminals). Perform a resistance test on the terminals located on top of the solenoid portion of the injector. Make sure that the multi-meter's test lead resistance is taken into consideration when resistance measurements are taken. Record the multi-meter's test lead resistance by touching the leads together on the lowest Ohms scale and mentally recording the resistance value. Subtract this value from the actual resistance measurement taken. See test table below.

Test Type	From	To	Expected Results
1. Resistance	Cylinder #1 injector, connector INJ1 terminal #1	Cylinder #1 injector, connector INJ1 terminal #2	Approx. <b>0.4 - 0.5 ohms</b>

A. If resistance test was successful, repair the internal harness between the Cylinder #1 injector and the connector INJ1.

B. If resistance test was not successful, replace the Cylinder #1 injector.

5. Operation: Check for ECU Voltages and Ground Continuity.

Vehicle Status (when removing ECU connector 1) Key Off Engine Off.

Vehicle Status (when performing test) Key On Engine Off.

Vehicle Status (when replacing ECU connector 1) Key Off Engine Off.

Remove connector 1 from the ECU and check for voltage and continuity at the appropriate pins defined in the test table below. Use the **0.43 mm (0.017 in)** diameter test probes from the Tier II (NEF) Diagnostic Repair Kit #380040185 when connecting the DMM to the ECU connector 1. Make sure the DMM's test lead resistance is taken into account when making any continuity measurements.

Important Note: Check and verify that the Vehicle Status is correct for each operation. Potential ECU damage could result when removing and replacing main ECU connectors if this is not followed.

Test Type	From	To	Expected Results
1. Voltage	ECU connector 1 pin 2, 3, 8, 9, 40	Ground (engine block)	Approx. <b>12.0 volts (DC)</b>
2. Continuity	ECU connector 1 pin 5, 6, 10, 11	Ground (engine block)	Approx. <b>0.0 - 0.1 ohms</b>

A. If the voltages and ground paths are correct, proceed to step 6.

B. If the voltages and ground paths are not correct, refer to product schematic and determine root cause of power and/or continuity problem(s).

6. Operation: Re-initialize the ECU.

Vehicle Status: Key On Engine Off.

## 3073-Cylinder 6 - Injector Cable Short Circuit (Low Side To Battery)

**NOTE:** This diagnostic procedure requires a good quality Digital Multi-meter (DMM) to be able to take accurate resistance measurements. The meter should be able to measure to a resolution of **0.1 ohms**. Some of the measurements required to be taken, could be as low as **0.4 ohms** and any inaccuracies in the DMM could cause a technician to take the wrong diagnostic path.

### Context:

The Engine Control Unit (ECU) generated an error associated with the injector power driver stage. The power stage component of the ECU energizes the injection system transistors and simultaneously observes the current flow (sense resistors) in the high-side and low-side switching branches. If there is a deviation from the expected current flow, the driver circuitry detects the specific error and reports it back to the ECU. The ECU will process the error message so that it records information on performed injections, cylinder bank specific errors and cylinder specific errors. The error message is then compared to applicable error patterns and if there is a match, a fault code is generated. If an error message doesn't match any pattern, the error is treated as unclassifiable. This monitoring function is performed once per camshaft revolution.

### Cause:

The Engine Control Unit (ECU) has determined that there is a fault associated with the current monitoring of the injector output power driver stage.

### Possible failure modes:

1. Faulty electrical wiring, short to high source or damaged wiring harness.
2. Faulty injection valve or shorted solenoid windings.
3. Faulty ECU, supply voltages or grounds.

### Solution:

1. Operation: Electrical Inspection.  
Vehicle Status: Key Off Engine Off.

Remove the following connector for electrical inspection:

1. ECU injector connector 3.
2. Valve cover connector VC3.

Inspect connector housing body/latch, pins and wiring harness for damage or corrosion.

- A. If damage is determined after careful inspection, repair wiring and/or replace connector parts to ensure a good and sound electrical connection.
  - B. If no damage is determined, proceed to step 2.
2. Operation: Injector Resistance Test Cylinder #5/6 injector connector VC3 to Cylinder #5/6 injector.  
Vehicle Status: Key Off Engine Off.

Remove connector VC3 and perform an injector resistance test on the Cylinder #5/6 injector connector VC3. Use the standard multi-meter test leads to access the connector pins. Make sure that the multi-meter's test lead resistance is taken into account when resistance measurements are taken. Record the multi-meter's test lead resistance by touching the leads together on the lowest Ohms scale and mentally recording the resistance value. Subtract this value from the actual resistance measurement taken. See test table below.

Test Type	From	To	Expected Results
1. Resistance	Cylinder #5/6 injector connector VC3 connector pin: 1	Cylinder #5/6 injector connector VC3 connector pin: 2	Approx. <b>0.4 - 0.5 ohms</b>

- A. If resistance test was not successful, proceed to step 4
  - B. If resistance test was successful, reconnect connector VC3. Proceed to step 3.
3. Operation: Injector Resistance Test ECU harness side of connector 3 to Cylinder #6 injector.

---

## 3088-Crankshaft Sensor - No Signal

### Context:

The Engine Control Unit (ECU) has reported an error with the monitoring of the increment speed (crankshaft speed) sensor. If the engine has a defective crankshaft speed sensor it can run off the segment speed (camshaft speed) sensor. This is referred to as backup mode. Diagnostics of the signal failure is only active if voltage is present at terminal 15 and no errors are active for the sensor supply voltage.

### Cause:

The ECU has determined that there is no signal from the crankshaft speed sensor. The engine is now operating in backup mode.

### Possible failure modes:

1. Faulty electrical wiring and/or connections.
2. Faulty crankshaft speed sensor.
3. Faulty ECU.

### Solution:

1. Verify this error code is still present and in an active state.
  - A. If the error is still present and active, continue with step **2**.
  - B. If the error is no longer present or is in an inactive state, return machine to proper operation.
2. Remove crankshaft speed sensor connector DG6 Incr. and inspect housing body/latch, pins and wiring harness for damage or corrosion. Also, inspect connector portion of the crankshaft speed sensor.
  - A. If damage is determined after careful inspection, repair wiring and/or replace connector parts to ensure a good and sound electrical connection. Replace crankshaft speed sensor if damaged.
  - B. If no damage is determined, leave connector disconnected and proceed to step **3**.
3. Check for faulty CKP, engine flywheel speed sensor. Place the ignition switch OFF. Connect the test lead labeled "Coolant/Fuel Temp Sensor" from the Tier II (NEF) Diagnostic Repair Kit 380040185 to access the sensor side of the terminals. Measure for resistance from the crankshaft speed sensor connector DG6 Incr. pin 1 to pin 2. There should be **750 - 1000  $\Omega$** .
  - A. If the resistance test does not fall in the specified range, replace crankshaft speed sensor.
  - B. If the resistance test does fall in the specified range, leave connector disconnected and proceed to step **4**.
4. Check output of crankshaft speed sensor. Place the ignition switch OFF when setting up the test. Make the following electrical tests in the table below. There will be (2) types of tests (in-line and single ended) that will need to be performed which use the test lead labeled "Coolant/Fuel Temp Sensor" from the Tier II (NEF) Diagnostic Repair Kit 380040185. Reference the descriptions below to make the proper electrical connections for each test type.

#### Single Ended Test Lead Connection Test (Standalone Crankshaft speed sensor Test)

Remove Crankshaft speed sensor connector and connect the above mentioned special test lead to the crankshaft speed sensor. Start the engine and measure the (AC) voltage using a multi-meter across the breakout alligator clips from the test leads. Use the test table below to determine the measurement results.

#### In-Line Test Lead Connection Test:

Remove crankshaft speed sensor connector and connect the above mentioned special test lead in-line with the sensor and the engine wiring harness. Make sure that the signal polarity is not swapped during the connection process. Start the engine and measure the (AC) voltage using a multi-meter across the breakout alligator clips from the test leads. Use the test table below to determine the measurement results.

#### Note:

The engine will be running off the camshaft speed sensor during the single ended test, if it isn't already (based on the fault code type). The engine can also be very hard to start when running exclusively off the camshaft speed

## 3096-ECM Busoff on vehicle CAN

**NOTE:** It is normal to log Controller Area Network (CAN) fault codes while the Dosing Control Unit (DCU) is being programmed. In this case, clear the fault codes from the ECU and DCU modules and retest the system.

**NOTE:** Check for multiple CAN fault codes. If there are CAN Bus fault codes, check the entire CAN bus circuit.

### Context:

The Engine Control Unit (ECU) did not receive a Controller Area Network (CAN) message from the Dosing Control Unit (DCU) within the allotted time limit.

### Cause:

The DCU is unable to communicate over the CAN bus.

### Possible failure modes:

1. The DCU is disconnected during power up.
2. A new DCU is being programmed.
3. The DCU experienced a power supply failure (i.e. a blown fuse, wiring, or power converter failure).
4. A problem in the primary CAN bus wiring.

### Solution:

1. Verify the fault is still present and in an active state.
  - A. If fault is still present and active, continue with step 2.
  - B. If the fault is no longer present or inactive, continue with step 5.

**NOTE:** It is normal to log Controller Area Network (CAN) fault codes while the Dosing Control Unit (DCU) is being programmed. In this case, clear the fault codes from the ECU and DCU modules and retest the system.

2. Inspect the wiring and connectors.

Verify all the connectors to the ECU and DCU are not damaged and are properly connected.

Verify the connector locks are not broken and securely hold the connectors in a connected and locked position. Replace the connectors if the locks are broken.

- A. If damaged wiring is found, repair the damaged wiring. Retest the circuit(s).
  - B. If there is no damage and the connectors are properly connected, continue to step 3.
3. Check the DCU connector for proper operation of the power supply and ground circuits.

Disconnect the harness connector to the DCU.

Measure the voltage from pin 3 to pin 14 of the DCU connector. The meter should read between **20–28 V**.

Measure the voltage from pin 4 to pin 15 of the DCU connector. The meter should read between **20–28 V**.

Measure the voltage from pin 24 of the DCU connector and chassis ground. The meter should read between **20–28 V**.

- A. All of the expected voltage measurements are not present, repair/replace the circuit to the DCU connector.
  - B. All of the expected voltage measurements are present, continue to step 4.
4. Measure the resistance of the CAN bus circuit. Verify the CAN Bus has the proper **54–66 Ω** meter reading.

If the CAN bus reading is **120 Ω**, a terminating resistor is missing or the CAN bus wiring is damaged. Replace the missing terminator or damaged CAN bus wiring.

If the CAN bus reading is open, locate and repair the damaged wiring or open (disconnected) connector.

## 3118-ECM 12V sensor supply voltage high

### Possible failure modes:

1. External power supply connected.
2. Faulty charging system.
3. Faulty engine controller.

### Solution:

1. Before proceeding clear the error code with the approved diagnostic equipment. Run the machine under normal conditions and retest.
  - A. If the error code is not active, check that the system is operating correctly.
  - B. If the error code is active, continue to step 2.
2. Check the battery power supply has not been connected to an external power supply.
  - A. If an external power supply is connected to the machine, disconnect and test the system for normal operation.
  - B. If an external power supply is not connected to the machine, continue to step 3.
3. Check the battery voltage on the instrument cluster.

Start the engine and run at **2000 RPM**.

- A. If the voltage displayed is not between **12 - 15 V**, continue to test for a fault in the charging system.
- B. If the battery voltage is okay, remove and replace the engine controller.

**Harnesses and connectors - Electrical schematic sheet 04 (55.100-C.20.E.04)**

A. The connectors are secure and the harness is free of damage. Go to step 3.

B. The connectors or the harness has damage. Repair or replace the harness or connectors as required. Return to step 1 to confirm elimination of fault.

3. Measure the resistance of the signal wires to chassis ground.

Turn the ignition switch OFF.

Disconnect **ECU** connector **X-120**.

Measure the resistance between **ECU** connector **X-120** pin 12 and chassis ground. The chassis ground connection must be clean and free of paint, oil, and dirt. The resistance should be greater than **20,000 Ω**. Wiggle the harness during measurement to reveal an intermittent condition.

Measure the resistance between **ECU** connector **X-120** pin 75 and chassis ground. The chassis ground connection must be clean and free of paint, oil, and dirt. The resistance should be greater than **20,000 Ω**. Wiggle the harness during measurement to reveal an intermittent condition.

A. The resistance is less than **20,000 Ω**. There is a short circuit to chassis ground in the harness. Repair or replace the harness as required. Return to step 1 to confirm elimination of the fault.

B. The resistance is greater than **20,000 Ω**. Go to step 4.

4. Test the grid heater relay circuit.

Turn the ignition switch OFF.

Reconnect **ECU** connector **X-120**.

Disconnect the grid heater relay.

Fabricate a jumper wire that will connect between connector **X-127** pin A and positive battery.

Connect the jumper wire between **X-127** pin A and positive battery.

Turn the ignition switch ON.

Fault code 3155 should no longer be active. Fault code 3154 is now active.

A. Fault code 3155 is still active. Fault code 3154 did not become active. There is a problem with the **ECU**. Temporarily replace the **ECU** and retest. Return to step 1 to confirm elimination of the fault.

B. Fault code 3113 is now active. Fault code 3114 is no longer active. There is a problem with the grid heater relay. Temporarily replace the relay and retest. Return to step 1 to confirm elimination of the fault.

**Harnesses and connectors - Electrical schematic sheet 04 (55.100-C.20.E.04)**

- A. If the resistance was within range, there is a short circuit condition in the injector harness, between connector INJ1, or INJ2 and connector VC1 pin 3, or 2, ECU connector 3 pin 13, or 6 or connector INJ3 and connector VC2 pin 3, ECU connector 3 pin 12. Locate and repair the shorted conductors.
- B. If the resistance was below range, the injector solenoid coil has failed. Replace the injector.
- 8. Use a DMM to check for continuity, on the engine injector harness side of ECU connector 3, from pins 4, 11, and 5 to all other populated pins in connector 3. There should not be continuity.
  - A. If there is continuity, record the pin numbers and use to locate and repair the shorted conductors.
  - B. If there is no continuity, the ECU may have failed. Attempt reloading the ECU software. If the fault reoccurs, replace the ECU.

## **3234-Injection Processor Error - SPI Communication Failure**

### **Context:**

The engine control unit (ECU) has detected that injection time is too long. The sum of all torque-forming energizing times of an individual cylinder exceeds the limit, calculated from the map (depending on the engine speed and the time since the overrun monitoring is active) for more than 100 test events (test frequency every **10 ms**). When the engine is in overrun operation the monitoring becomes active and the current injection energizing time is compared with a maximum permissible time limit. If the limit is exceeded an ECU recovery (reset ) is triggered and if the error reoccurs in the same driving cycle, the torque-determining power stages are irreversibly shut off. The basic idea is that the operator reacts to an unintentional torque increase, caused by a malfunction of the ECU, by releasing the accelerator pedal (reducing engine speed) which causes the engine to enter the overrun operation mode. Overrun monitoring is only released if various conditions are met, such as no accelerator pedal activation, no activated cruise control, no intervention of the vehicle dynamic control or gearbox control is present, etc. This failure could be the result of electronic disturbances, a requested torque increase via tester, the wrong application of injection relevant parameters, or a defective ECU. If this failure persists, the ECU may need to be replaced.

## 3256-ADC Monitoring Queue Error

### Cause:

1. Internal error within the ECU.

### Solution:

1. Verify that the fault code is active.

Connect the Electronic Service Tool to the service tool connector.

To check for fault codes: Start and operate the machine.

- A. Fault code 3256 is not recorded again. OK to return the machine to service.
  - B. Fault code 3256 is active along with other fault codes. Troubleshoot all active fault codes before troubleshooting fault code 3256. Return to step **1** to confirm elimination of the fault.
  - C. Fault code 3256 is recorded again. No other fault codes are active. Go to step **2**.
2. Reset Engine Control Unit (ECU).

Reset Engine Control Unit (ECU) by turning ignition switch OFF then back to the ON position.

- A. Fault code 3256 is no longer active. Return to step **1** to confirm elimination of fault.
  - B. Fault code 3256 is still active. Go to step **3**.
3. Replace ECU (Engine Control Unit).

Remove and replace ECU (Engine Control Unit).

- A. Return to step **1** to confirm elimination of fault.

## 3284-Sensor Supply Voltage 2 - Low

### Cause:

The engine controller provides 3 independent 5V voltage supplies for the sensors. The air humidity/temperature sensor is connected to 5V supply circuit 2, ECU connector 1 pin 68.

### Possible failure modes:

1. Wiring or circuits shorted to chassis ground or negative battery.
2. Faulty alternator output.
3. Faulty reading from ECU.

### Solution:

1. Verify that the fault code is still active.

Connect the Electronic Service Tool to the service tool connector.

To check for fault codes: Start and operate the machine.

A. Fault code is not recorded again. OK to return the machine to service.

B. Fault code 3284 is recorded again. Go to step 2.

2. Measure the ECU unswitched input voltage.

Turn ignition switch OFF.

Disconnect Engine Control Unit (ECU) connector **X-120**.

Turn the ignition switch ON.

Measure the voltage between ECU connector **X-120** pin 2 and **X-120** pin 5. The voltage should be greater than **20 V**.

Measure the voltage between ECU connector **X-120** pin 3 and **X-120** pin 6. The voltage should be greater than **20 V**.

Measure the voltage between ECU connector **X-120** pin 8 and **X-120** pin 10. The voltage should be greater than **20 V**.

Measure the voltage between ECU connector **X-120** pin 9 and **X-120** pin 11. The voltage should be greater than **20 V**.

Measure the voltage between ECU connector **X-120** pin 40 and chassis ground. The chassis ground connection must be clean and free of paint, oil and dirt. The voltage should be greater than **20 V**.

A. The voltage is less than **20 V**. There is a problem with the battery supply to the ECU. Repair as required. Check fuse **F-009** and **F-032**. Return to step 1 to confirm elimination of fault.

B. The voltage is greater than **20 V** Go to step 3.

3. Measure the resistance of the harness wires to chassis ground.

Turn the ignition switch OFF.

Disconnect the ECU connector 1.

Measure the resistance between ECU connector 1, pin 68 and chassis ground. The chassis ground connection must be clean and free of paint, oil and dirt. The resistance should be greater than **20,000 Ω**. Wiggle the harness during measurement to reveal an intermittent condition.

A. The resistance is greater than **20,000 Ω**. There is a problem with the ECU. Temporarily replace the ECU and retest. Return to step 1 to confirm elimination of fault.

D. The resistance is greater than **133 Ω**. Go to Step **6**.

4. Measure the resistance between the CAN High and CAN Low signal wires.

Turn the ignition switch OFF.

Disconnect all modules on the CAN bus.

Measure the resistance between CAN High (diagnostic connector pin C) and CAN Low (diagnostic connector pin D).

A. The resistance is greater than **20,000 Ω**. Connect each component to the CAN Bus one at a time while measuring the resistance. The resistance should be greater than **54 Ω**. Replace the module that drops the CAN Bus resistance below **54 Ω**. Return to Step **1** to confirm elimination of the fault.

B. The resistance is less than **54 Ω** there is a short circuit between the CAN High and CAN Low wires. Repair or replace the harness as required. Return to test Step **1** to confirm elimination of the fault.

5. Measure harness resistance between chassis ground and positive battery.

Turn the ignition switch OFF.

Disconnect the instrument cluster connector, **X-058**.

Disconnect all devices connected to the CAN bus.

Measure the resistance between **X-058** pin 4 and chassis ground. The chassis ground connection must be clean and free of paint, oil, and dirt. The resistance should be greater than **20,000 Ω**. Wiggle the harness during measurement to reveal an intermittent condition.

Measure the resistance between **X-058** pin 4 and switched battery **X-059** pin 21. The resistance should be greater than **20,000 Ω**. Wiggle the harness during measurement to reveal an intermittent condition.

Measure the resistance between **X-058** pin 4 and unswitched positive battery **X-059** pin 14. The resistance should be greater than **20,000 Ω**. Wiggle the harness during measurement to reveal an intermittent condition.

Measure the resistance between **X-058** pin 3 and chassis ground. The chassis ground connection must be clean and free of paint, oil, and dirt. The resistance should be greater than **20,000 Ω**. Wiggle the harness during measurement to reveal an intermittent condition.

Measure the resistance between **X-058** pin 3 and switched battery **X-059** pin 21. The resistance should be greater than **20,000 Ω**. Wiggle the harness during measurement to reveal an intermittent condition.

Measure the resistance between **X-058** pin 3 and unswitched positive battery **X-059** pin 14. The resistance should be greater than **20,000 Ω**. Wiggle the harness during measurement to reveal an intermittent condition.

A. All resistance measurements are greater than **20,000 Ω**. Verify the ECU and other CAN Bus modules are powered and operational. Verify that all minus battery and chassis ground connections to the CAN Bus modules are clean and secure. Repair as required. Return to Step **1** to confirm elimination of the fault.

B. The resistance is less than **20,000 Ω**. There is a short circuit in the CAN bus to chassis ground or positive battery. Temporarily replace the CAN bus wires and retest. Repair or replace the harness as required. Return to Step **1** to confirm elimination of the fault code.

6. Measure the resistance through the CAN bus circuit.

Turn the ignition switch OFF. Disconnect all components connected to the CAN Bus.

Fabricate a jumper **20 cm (8 in)** that will connect between ECU connector **X-120** pin 34 and pin 35.

Connect the jumper wire between **X-120** pin 34 and 35.

Measure the resistance between diagnostic connector pin C and pin D. The resistance should be less than **10 Ω**. Wiggle the harness during measurement to reveal an intermittent condition.

## **3371-Torque limitation due to Fuel quantity Limitation**

**Context:**

The Engine Control Unit (ECU) has detected an active power reduction due to limiting fuel quantity. This error is for informational purposes and is initiated by a power reduction due to limiting fuel quantity being active causing a torque limitation greater than **25 %** of the desired torque for longer than 60 seconds and is reset once the torque limitation due to limiting fuel quantity is less than **25 %** of the desired torque over 10 seconds. Though no action is necessary due to this error, if the power reduction occurred due to an actual defect, the error triggering the torque limitation should also be in fault memory. Follow the troubleshooting procedure for that error.

## **3530-NOx sensor failure - short circuit**

### **Context:**

The engine control unit (ECU) has detected a fault with the NOx sensor. This fault is a result of an issue with the NOx sensor and/or the wiring related to the NOx sensor. If this fault is present and active, ensure the NOx sensor is receiving **24 V** on pin 1 and a sufficient ground on pin 2. If power and ground is present, clear this code and continue operation. If the code resets, the sensor is damaged, replace the sensor.

Error detection and healing is disabled during following conditions: **6 s** after start of ECU initialization, during engine start and **6 s** after end of start state, if battery voltage is below **10.1 V** including **1 s** waiting time after voltage is above threshold, at least one CAN controller (CAN A, CAN B, CAN C) is in the bus-off state including a waiting time of **1 s** after bus is on again, the ECU is in the afterrun state. Monitoring is only active after the dew point detection has been sent.

## 3557-Humidity sensor possibly saturated with water droplets - signal ratio above limit

### Context:

If the value of the air humidity sensor is greater than **4.9 V** over a period of **0.5 s**. This error will correct itself once the humidity value is below the fault threshold for a period greater than **2.0 s**.

### Cause:

Sensor is possibly saturated with water droplets.

### Possible failure modes:

1. The humidity sensor is saturated with water.
2. A short circuit in the humidity sensor signal wire.
3. Faulty humidity sensor.
4. Faulty ECU.

### Solution:

1. Verify that the fault code is active.

Connect the Electronic Service Tool to the service tool connector.

To check for fault code: Start and operate machine.

A. The fault is not recorded again. OK to return the machine to service.

B. Fault code 3557 is recorded again. Go to Step 2.

2. Verify that the wiring and connectors are free of damage.

Inspect the humidity sensor for excessive moisture.

Inspect the **ECU** and the humidity sensor connections. All connections should be secure, tight, free of corrosion, abrasion and damage.

Inspect the harness from the **ECU** to the humidity sensor. Verify that the harness is free of damage, corrosion, abrasion and incorrect attachment.

## 3589-Plausibility check of catalyst system - temperature deviation between up and downstream catalyst temperature too high during operation

### Context:

The temperature sensors downstream and upstream of the SCR catalyst, together with the ambient temperature signal are checked for static plausibility against each other. This is done once for each driving cycle and only during cold start when all temperatures should still be the same. Depending on the availability/defectiveness of the temperature sensors, the plausibility check can vary.

### Cause:

Downstream temperatures are not plausible. There is a difference of **20 °C (68.0 °F)**, between the sensors.

### Possible failure modes:

1. Faulty downstream temperature sensor.
2. Faulty electrical wiring or connectors.

### Solution:

1. Verify this error code is still present and in an active state.
  - A. If the error is still present and active, continue with step **2**.
  - B. If the error is no longer present or is in an inactive state, continue with step **5**.
2. Ensure the engine has been allowed to cool down for over **600 min**. Disconnect the wiring harness from the ambient temperature sensor. Use a multi-meter to measure the resistance from ambient temperature sensor connector pin 3 to pin 4. There should be approximately

Temperature	Resistance (Approximately)
<b>-40 °C (-40.0 °F)</b>	<b>42172 Ω</b>
<b>-30 °C (-22.0 °F)</b>	<b>24760 Ω</b>
<b>-20 °C (-4.0 °F)</b>	<b>14995 Ω</b>
<b>-10 °C (14.0 °F)</b>	<b>9348 Ω</b>
<b>0 °C (32.0 °F)</b>	<b>5988 Ω</b>
<b>10 °C (50.0 °F)</b>	<b>3933 Ω</b>
<b>20 °C (68.0 °F)</b>	<b>2644 Ω</b>
<b>30 °C (86.0 °F)</b>	<b>1817 Ω</b>
<b>40 °C (104.0 °F)</b>	<b>1274 Ω</b>
<b>50 °C (122.0 °F)</b>	<b>910 Ω</b>
<b>60 °C (140.0 °F)</b>	<b>662 Ω</b>
<b>70 °C (158.0 °F)</b>	<b>489 Ω</b>
<b>80 °C (176.0 °F)</b>	<b>367 Ω</b>
<b>90 °C (194.0 °F)</b>	<b>279 Ω</b>

- A. If ambient temperature sensor test is good, continue with step **3**.
  - B. If the ambient temperature sensor test fails, replace the sensor.
3. Check upstream and downstream temperature sensors. Disconnect the wiring harness from the upstream temperature sensor. Use a multi-meter to measure the resistance on the upstream temperature sensor connector from pin 1 to pin 2. Use the chart below for specifications. Then disconnect the wiring harness from the downstream temperature sensor. Use a multi-meter to measure the resistance on the upstream temperature sensor connector from pin 1 to pin 2. Use the chart below for specifications.

Temperature	Resistance (Approximately)
<b>-65 °C (-85.0 °F)</b>	<b>150 Ω</b>
<b>0 °C (32.0 °F)</b>	<b>200 Ω</b>

## 4103-Right Pump Forward Solenoid High Side Shorted to Power

### Context:

The UCM detects a short circuit to another voltage source in the right forward solenoid circuit, **X-016** pin 19.

### Cause:

There is a short circuit to another voltage source in the right forward solenoid circuit, **X-016** pin 19.

### Possible failure modes:

1. Short circuit in the right forward solenoid circuit.
2. Faulty right forward solenoid.
3. Faulty UCM.

### Solution:

1. Verify that the fault code is active.

Connect the Electronic Service Tool to the service tool connector.

To check for fault codes: Start and operate the machine.

A. The fault code is not recorded again. OK to return the machine to service.

B. Fault code 4103 is recorded again. Go to step **2**.

2. Verify that the wiring and connectors are free of damage.

Inspect the **UCM** and the right forward solenoid connections. All connections should be secure, tight, free of corrosion, abrasion and damage.

Inspect the harness from the **UCM** to the right forward solenoid. Verify that the harness is free of damage, corrosion, abrasion and incorrect attachment.

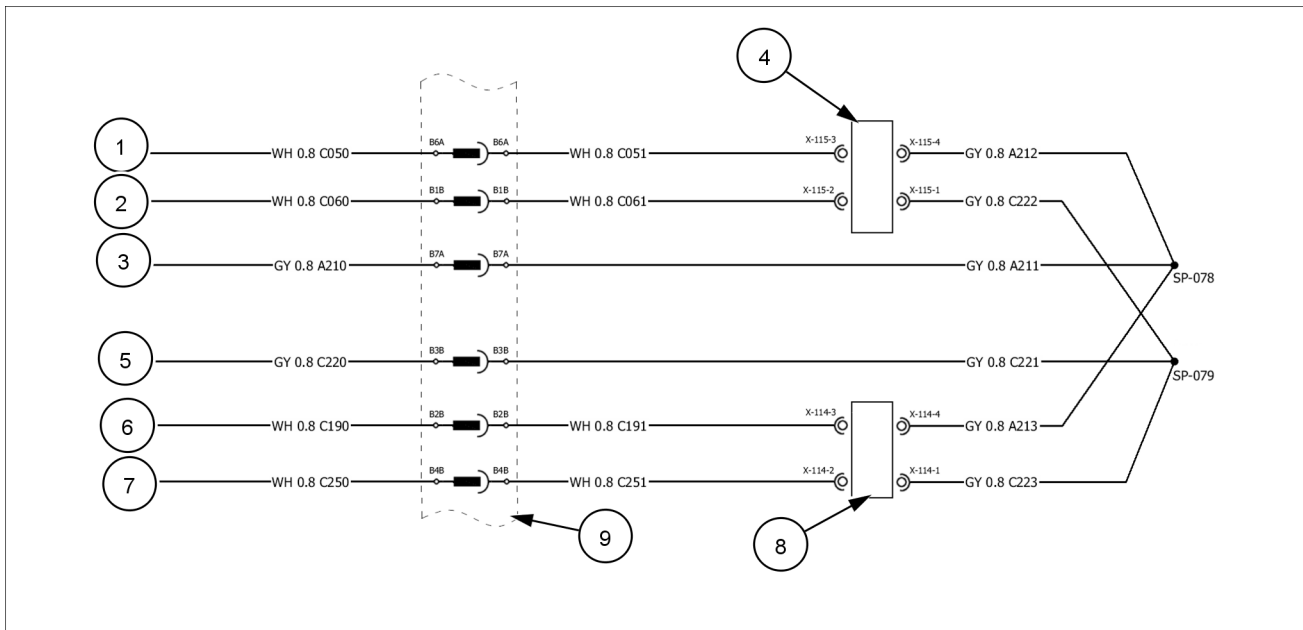

RAIL12DOZ0270FA 1

Schematic legend			
(1)	<b>UCM connector X-016</b> Pin 5 L Pump FWD (Front A) Fault Codes 4111, 4112, 4113, 4114, and 4302	(6)	<b>UCM connector X-016</b> Pin 22 REV Pump RTN (Both B) Fault Codes 4311, 4313 and 4312
(2)	<b>UCM connector X-016</b> Pin 6 L Pump REV (Front B) Fault Codes 4131, 4132, 4133, 4134, and 4312	(7)	<b>UCM connector X-016</b> Pin 19 R Pump FWD (Rear A) Fault Codes 4101, 4102, 4103, 4104, and 4302
(3)	<b>UCM connector X-014</b> Pin 21 FWD Pump RTN (Both A) Fault Codes 4301, 4303, and 4302	(8)	<b>UCM connector X-016</b> Pin 25 R Pump REV (Rear B) Fault Codes 4121, 4122, 4123, 4124, and 4312
(4)	Left Pump Connector <b>X-115</b>	(9)	Right Pump Connector <b>X-114</b>
(5)	Connector X-001/ X-090		

A. The connectors are secure and the harness is free of damage. Go to step 3.

B. The connectors or the harness has damage. Repair or replace the harness or connectors as required. Return to step 1 to confirm elimination of fault.

3. Test the circuit.

Turn the ignition switch OFF.

Disconnect the right reverse solenoid.

Turn the ignition switch ON.

Access the fault code screen on the EST.

Fault code 4122 should no longer be active. Fault code 4121 is now active. Fault code 4101 will also be active, ignore this fault code.

A. Fault code 4122 is no longer active. Fault code 4121 is now active. Temporarily replace the solenoid and retest. Return to step 1 to confirm elimination of the fault.

B. Fault code 4122 is still present and active. Fault code 4121 did not become active. Go to step 4.

4. Measure the resistance through the signal wire.

Turn the ignition switch OFF.

Disconnect **UCM** connector **X-016**.

Measure the resistance between **X-016** pin 25 and chassis ground. The chassis ground connection must be clean and free of paint, oil, and dirt. The resistance should be greater than **20,000 Ω**. Wiggle the harness during measurement to reveal an intermittent condition.

A. The resistance is greater than **20,000 Ω**. Temporarily replace the **UCM** and retest. Return to step 1 to confirm elimination of the fault.

B. The resistance is less than **20,000 Ω**, there is a short circuit to chassis ground in the wiring from the **UCM** to the solenoid. Repair or replace the harness as required. Return to step 1 to confirm elimination of fault.

**Harnesses and connectors - Electrical schematic sheet 09 (55.100-C.20.E.09)**

**Harnesses and connectors - Electrical schematic sheet 23 (55.100-C.20.E.23)**

Schematic legend			
(1)	<b>UCM</b> connector <b>X-018</b> Pin 6 Right Motor Solenoid Signal Fault Codes 4141, 4142, 4143, 4144, and 4322	(4)	Connector <b>X-001/ X-090</b>
(2)	<b>UCM</b> connector <b>X-016</b> Pin 21 Right/ Left Motor Solenoid Return Fault Codes 4321, 4323, and 4322	(5)	Right Motor Solenoid Connector <b>X-131</b>
(3)	<b>UCM</b> connector <b>X-018</b> Pin 19 Left Motor Solenoid Signal Fault Codes 4151, 4152, 4153, 4154, and 4322	(6)	Left Motor Solenoid Connector <b>X-132</b>

A. The connectors are secure and the harness is free of damage. Go to step 3.

B. The connectors or the harness has damage. Repair or replace the harness or connectors as required. Return to step 1 to confirm elimination of fault.

3. Test the circuit.

Turn the ignition switch OFF.

Disconnect the right motor solenoid.

Turn the ignition switch ON.

Access the fault code screen on the EST.

Fault code 4142 should no longer be active. Fault code 4141 is now active.

A. Fault code 4142 is no longer active. Fault code 4141 is now active. Temporarily replace the solenoid and retest. Return to step 1 to confirm elimination of the fault.

B. Fault code 4142 is still present and active. Fault code 4141 did not become active. Go to step 4.

4. Measure the resistance through the signal wire.

Turn the ignition switch OFF.

Disconnect **UCM** connector **X-018**.

Measure the resistance between **X-018** pin 6 and chassis ground. The chassis ground connection must be clean and free of paint, oil, and dirt. The resistance should be greater than **20,000 Ω**. Wiggle the harness during measurement to reveal an intermittent condition.

A. The resistance is greater than **20,000 Ω**. Temporarily replace the **UCM** and retest. Return to step 1 to confirm elimination of the fault.

B. The resistance is less than **20,000 Ω**, there is a short circuit to chassis ground in the wiring from the **UCM** to the solenoid. Repair or replace the harness as required. Return to step 1 to confirm elimination of fault.

**Harnesses and connectors - Electrical schematic sheet 09 (55.100-C.20.E.09)**

**Harnesses and connectors - Electrical schematic sheet 23 (55.100-C.20.E.23)**

## 4163-Park Brake Valve Shorted to Power

**Context:**

The UCM detects a short circuit to another voltage source in the park brake solenoid circuit, **X-019** pin 27. Ground drive is disabled while fault code 4163 is active.

**Cause:**

There is a short circuit to another voltage source in the park brake solenoid circuit, **X-019** pin 27.

**Possible failure modes:**

1. Short circuit in the park brake solenoid circuit.
2. Faulty park brake solenoid.
3. Faulty UCM.

**Solution:**

1. Verify that the fault code is active.

Connect the Electronic Service Tool to the service tool connector.

To check for fault codes: Start and operate the machine.

A. The fault code is not recorded again. OK to return the machine to service.

B. Fault code 4163 is recorded again. Go to step 2.

2. Verify that the wiring and connectors are free of damage.

Inspect the **UCM** and the park brake solenoid connections. All connections should be secure, tight, free of corrosion, abrasion and damage.

Inspect the harness from the **UCM** to the park brake solenoid. Verify that the harness is free of damage, corrosion, abrasion and incorrect attachment.

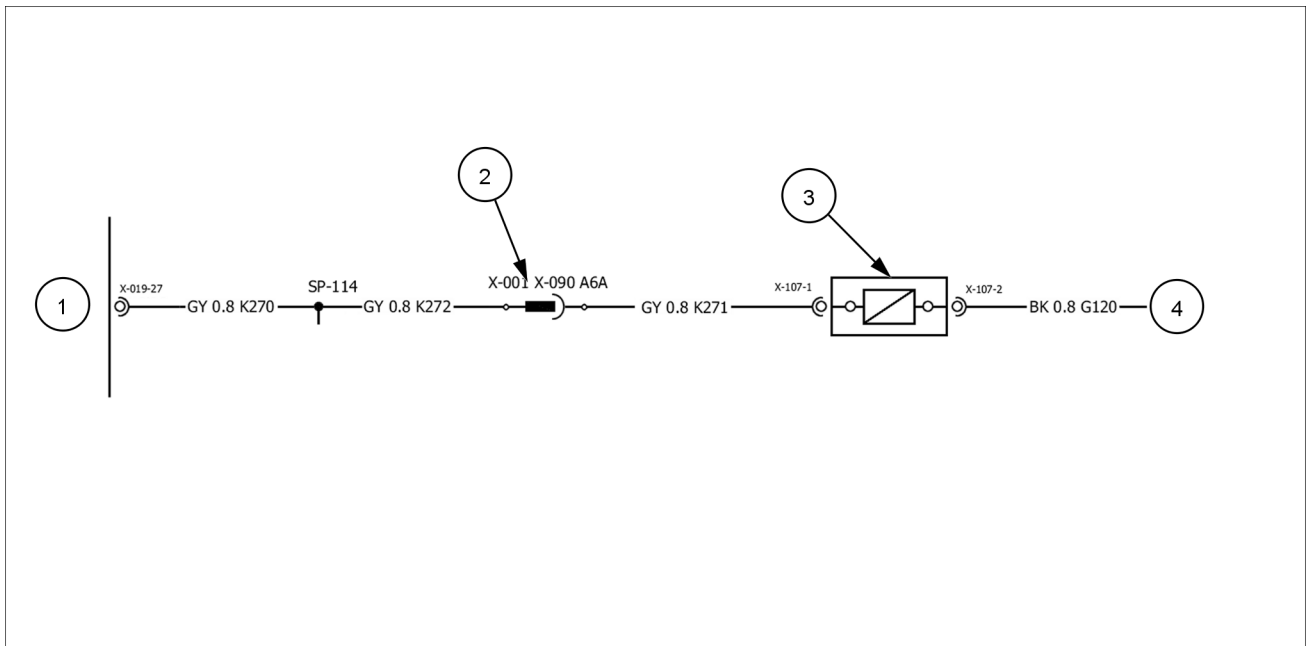

RAIL12DOZ0202FA 1

Schematic legend			
(1)	UCM connector X-019 Pin 27	(3)	Park Brake Solenoid Connector X-107
(2)	Connector X-001/X-090 Pin A6B	(4)	Engine Ground X-GND6

B. One or both resistance measurements are greater than **10 Ω**, there is an open circuit in the **UCM** wiring. Check splice **SP-079**. Repair or replace the harness as required. Return to step **1** to confirm elimination of fault.

**Harnesses and connectors - Electrical schematic sheet 09 (55.100-C.20.E.09)**

**Harnesses and connectors - Electrical schematic sheet 23 (55.100-C.20.E.23)**

Schematic legend			
(1)	<b>UCM</b> connector <b>X-017</b> Pin 26, Joystick ground 2	(5)	<b>UCM</b> connector <b>X-015</b> Pin 19, Left joystick F-B 1
(2)	<b>UCM</b> connector <b>X-016</b> Pin 20, Joystick ground 1	(6)	<b>UCM</b> connector <b>X-015</b> Pin 20, Left joystick F-B 2
(3)	<b>UCM</b> connector <b>X-014</b> Pin 4, Joystick sensor supply 2 (5V)	(7)	<b>UCM</b> connector <b>X-015</b> Pin 21, Left joystick L-R 1
(4)	<b>UCM</b> connector <b>X-014</b> Pin 2, Joystick sensor supply 3 (5V)	(8)	<b>UCM</b> connector <b>X-015</b> Pin 22, Left joystick L-R 2
		(9)	Trans joystick Connector <b>X-028</b>

A. The connectors are secure and the harness is free of damage. Go to step 3.

B. The connectors or the harness has damage. Repair or replace the harness or connectors as required. Return to step 1 to confirm elimination of fault.

3. Measure the resistance of the signal wire to chassis ground.

Turn the ignition switch OFF.

Disconnect **UCM** connector **X-015**.

Disconnect drive joystick connector **X-028**.

Measure the resistance between **UCM** connector **X-015** pin 19 and chassis ground. The chassis ground connection must be clean and free of paint, oil, and dirt. The resistance should be greater than **20,000 Ω**. Wiggle the harness during measurement to reveal an intermittent condition.

A. The resistance is greater than **20,000 Ω**. Go to step 4.

B. The resistance is less than **20,000 Ω**. There is a short circuit to chassis ground. Repair or replace the wiring harness as required. Return to step 1 to confirm elimination of the fault.

4. Measure the resistance through the circuit.

Turn the ignition switch OFF.

Fabricate a jumper wire that will connect between drive joystick connector **X-028** pin 10 and chassis ground.

Connect the jumper wire between **X-028** pin 10 and chassis ground. The chassis ground connection must be clean and free of paint, oil, and dirt.

Disconnect **UCM** connector **X-015**.

Measure the resistance between **X-015** pin 19 and chassis ground. The resistance should be less than **10 Ω**. Wiggle the harness during measurement to reveal an intermittent condition.

A. The resistance is less than **10 Ω**. Go to step 5.

B. The resistance is greater than **10 Ω**. There is an open circuit in the wiring between the **UCM** and connector **X-028**. Repair or replace the harness as required. Return to step 1 to confirm elimination of the fault.

5. Test the UCM.

Turn the ignition switch OFF.

Reconnect joystick connector **X-028**.

Leave **UCM** connector **X-015** disconnected.

Remove the wire **B190 WH** from **X-015** pin 19.

Insert a jumper wire into the empty cavity on **X-015** pin 19.

Connect the jumper wire to **X-014** pin 3.

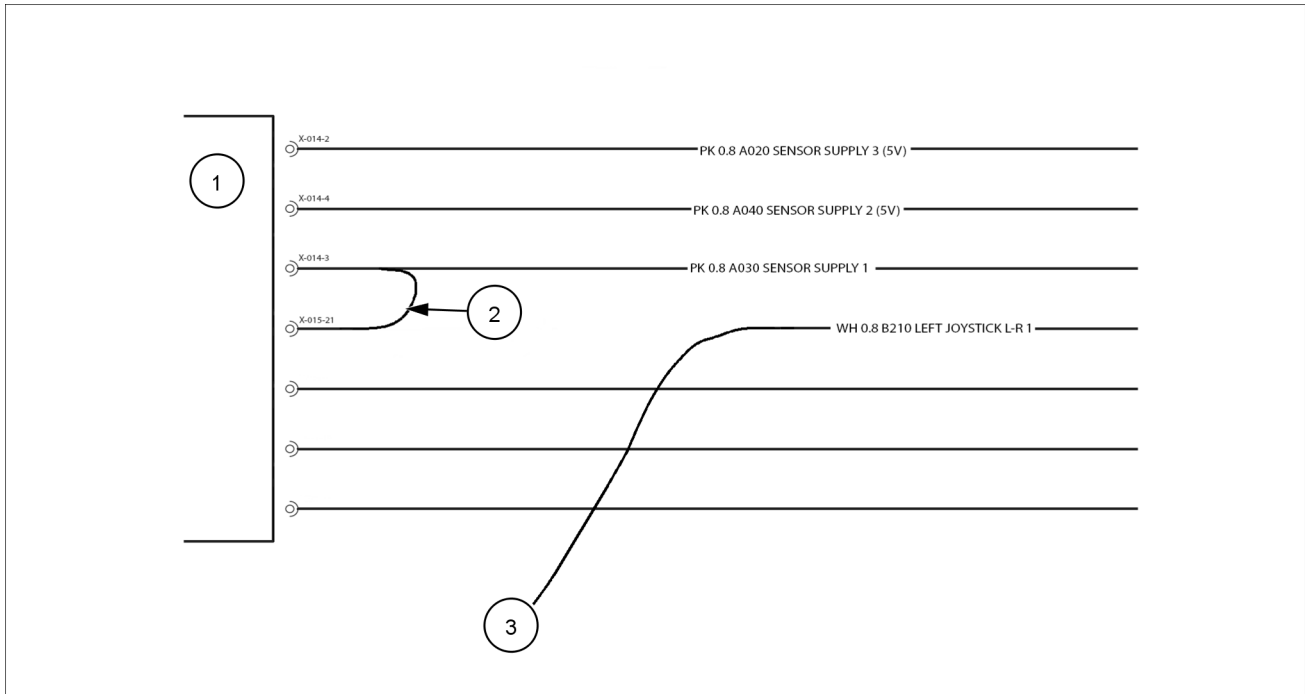

RAIL12DOZ0615FA 2

Schematic legend			
(1)	UCM Connector <b>X-014</b> UCM Connector <b>X-015</b>	(3)	Wire <b>WH B210</b> removed from connector <b>X-015</b> Pin 21
(2)	Jumper wire installed between <b>X-014</b> pin 3 and <b>X-015</b> pin 21		

Reconnect UCM connector **X-015**.

Turn the ignition switch ON. Access the EST fault code screen.

Fault code 4521 should no longer be active. Fault code 4523 is now active.

A. Fault code 4521 is no longer active. Fault code 4523 is now active. Temporarily replace the joystick and retest. Return to step 1 to confirm elimination of the fault.

B. Fault code 4521 is still present and active. 4523 did not become active. Temporarily replace the **UCM** and retest. Return to step 1 to confirm elimination of the fault.

**Harnesses and connectors - Electrical schematic sheet 22 (55.100-C.20.E.22)**

**Harnesses and connectors - Electrical schematic sheet 08 (55.100-C.20.E.08)**

**Harnesses and connectors - Electrical schematic sheet 09 (55.100-C.20.E.09)**

## 4563-Blade Shake/Auto-Manual Button Shorted to Power

### Context:

The **UCM** detects a short circuit to another voltage source in the joystick auto/manual/blade shake button, **X-017** pin 23. The voltage on **X-017** pin 23 is greater than **8 V** for a period greater than **1 s**.

### Cause:

The **UCM** detects a short circuit to another voltage source in the joystick auto/manual/blade shake signal line, **X-017** pin 23.

### Possible failure modes:

1. A short circuit in the wiring or circuits.
2. Faulty transmission joystick.
3. Faulty UCM.

### Solution:

1. Verify that the fault code is active.

Connect the Electronic Service Tool to the service tool connector.

To check for fault codes: Start and operate the machine.

A. The fault code is not recorded again. OK to return the machine to service.

B. Fault code 4563 is recorded again. Go to step 2.

2. Verify that the wiring and connectors are free of damage.

Inspect the **UCM** and the transmission joystick connections. All connections should be secure, tight, free of corrosion, abrasion and damage.

Inspect the harness from the **UCM** to the transmission joystick. Verify that the harness is free of damage, corrosion, abrasion and incorrect attachment.

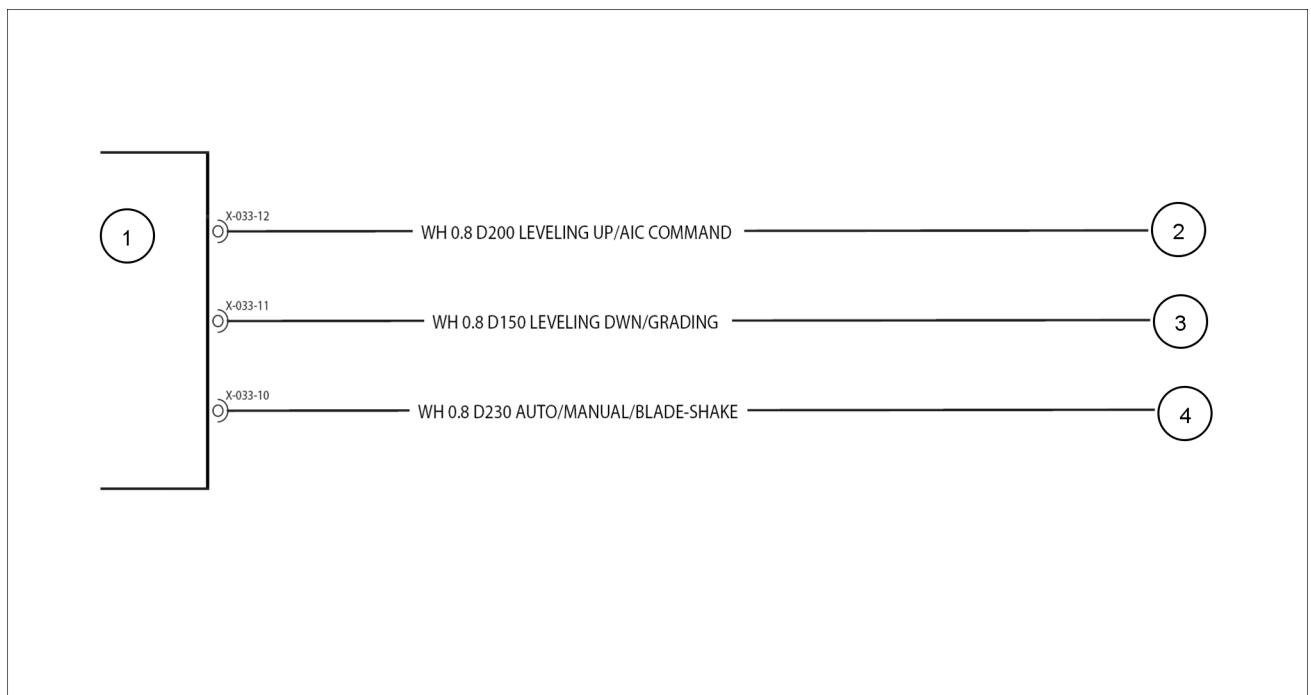

RAIL12DOZ0611FA 1

Schematic legend			
(1)	<b>UCM</b> connector <b>X-021</b> Pin 7, Blade lift	(5)	<b>UCM</b> connector <b>X-015</b> Pin 2, Blade lift/lower ground
(2)	Connector <b>X-001/X-090</b> Pin <b>B6C</b>	(6)	Blade lower solenoid Connector <b>X-097</b>
(3)	Blade lift solenoid Connector <b>X-098</b>	(7)	<b>UCM</b> connector <b>X-021</b> Pin 6, Blade lower
(4)	Connector <b>X-090/X-001</b> Pin <b>B8C</b>		

A. The connectors are secure and the harness is free of damage. Go to step **3**.

B. The connectors or the harness has damage. Repair or replace the harness or connectors as required. Return to step **1** to confirm elimination of fault.

3. Test the circuit.

Turn the ignition switch OFF.

Disconnect the blade lower solenoid.

Turn the ignition switch ON.

Access the fault code screen on the EST.

Fault code 5112 should no longer be active. Fault code 5111 is now active.

A. Fault code 5112 is no longer active. Fault code 5111 is now active. Temporarily replace the solenoid and retest. Return to step **1** to confirm elimination of the fault.

B. Fault code 5112 is still present and active. Fault code 5111 did not become active. Go to step **4**.

4. Measure the resistance through the signal wire.

Turn the ignition switch OFF.

Disconnect **UCM** connector **X-021**.

Measure the resistance between **X-021** pin 6 and chassis ground. The chassis ground connection must be clean and free of paint, oil, and dirt. The resistance should be greater than **20,000 Ω**. Wiggle the harness during measurement to reveal an intermittent condition.

A. The resistance is greater than **20,000 Ω**. Temporarily replace the **UCM** and retest. Return to step **1** to confirm elimination of the fault.

B. The resistance is less than **20,000 Ω**, there is a short circuit to chassis ground in the wiring from the **UCM** to the solenoid Repair or replace the harness as required. Return to step **1** to confirm elimination of fault.

**Harnesses and connectors - Electrical schematic sheet 25 (55.100-C.20.E.25)**

**Harnesses and connectors - Electrical schematic sheet 08 (55.100-C.20.E.08)**

## 5133-Blade Tilt Right Solenoid High Side Shorted to Power

### Context:

The UCM detects a short circuit to another voltage source in the blade tilt right solenoid circuit, **X-019** pin 25.

### Cause:

There is a short circuit to another voltage source in the blade tilt right solenoid circuit, **X-019** pin 25.

### Possible failure modes:

1. Short circuit in the blade tilt right solenoid circuit.
2. Faulty blade tilt right solenoid.
3. Faulty UCM.

### Solution:

1. Verify that the fault code is active.

Connect the Electronic Service Tool to the service tool connector.

To check for fault codes: Start and operate the machine.

A. The fault code is not recorded again. OK to return the machine to service.

B. Fault code 5133 is recorded again. Go to step 2.

2. Verify that the wiring and connectors are free of damage.

Inspect the **UCM** and the blade tilt right solenoid connections. All connections should be secure, tight, free of corrosion, abrasion and damage.

Inspect the harness from the **UCM** to the blade tilt right solenoid. Verify that the harness is free of damage, corrosion, abrasion and incorrect attachment.

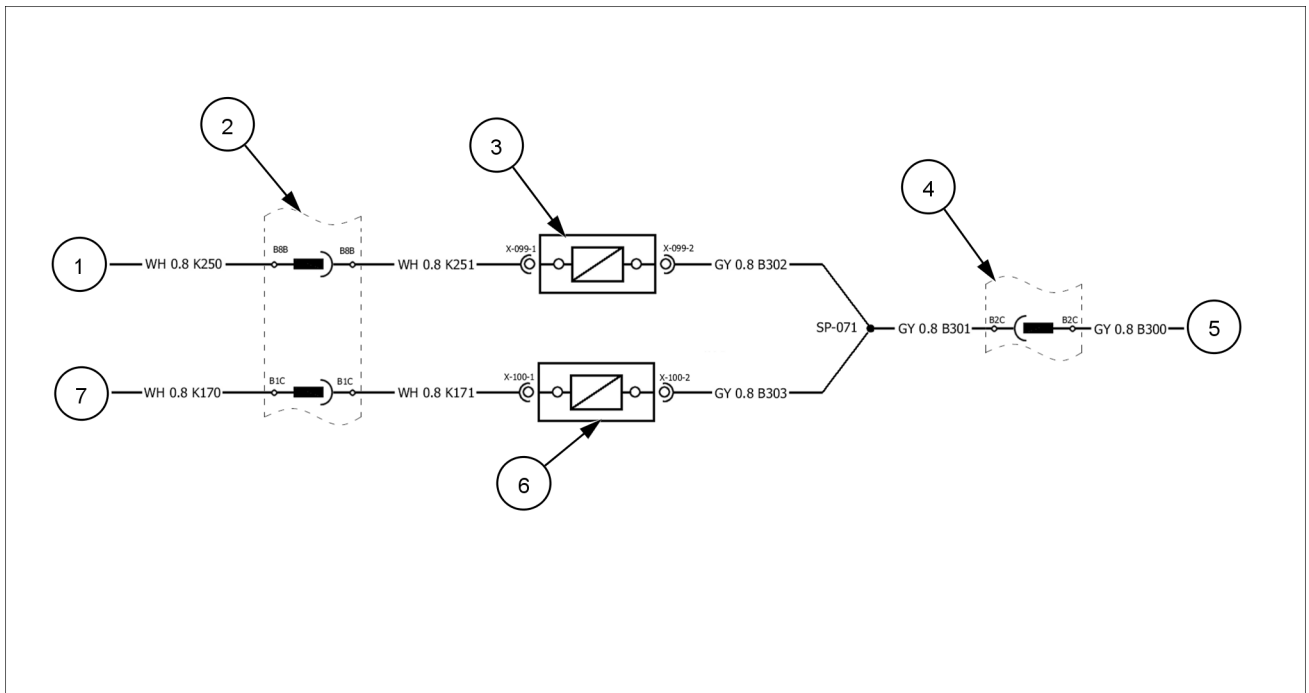

RAIL12DOZ0237FA 1

Schematic legend			
(1)	<b>UCM</b> connector <b>X-019</b> Pin 33, Blade angle right	(5)	<b>UCM</b> connector <b>X-015</b> Pin 10, Blade angle right/left ground
(2)	Connector <b>X-001/X-090</b> Pin <b>B3C</b> and Pin <b>B4C</b>	(6)	Blade angle left solenoid Connector <b>X-093</b>
(3)	Blade angle right solenoid Connector <b>X-094</b>	(7)	<b>UCM</b> connector <b>X-019</b> Pin 32, Blade angle left
(4)	Connector <b>X-090/X-001</b> Pin <b>B5C</b>		

A. The connectors are secure and the harness is free of damage. Go to step 3.

B. The connectors or the harness has damage. Repair or replace the harness or connectors as required. Return to step 1 to confirm elimination of fault.

3. Measure the voltage on the signal wire.

Turn the ignition switch OFF.

Disconnect **UCM** connector **X-019**.

Disconnect the blade angle left solenoid.

Turn the ignition switch ON.

Measure the voltage between **X-019** pin 32 and chassis ground. The chassis ground connection must be clean and free of paint, oil, and dirt. The voltage should be less than **0.5 V**.

A. The voltage is less than **0.5 V**. Go to step 4.

B. The voltage is greater than **0.5 V**. There is a short circuit to another voltage source. Repair or replace the harness as required. Return to step 1 to confirm elimination of fault.

4. Test the circuit.

Turn the ignition switch OFF. Reconnect the **UCM** connector.

Disconnect the blade angle left solenoid.

Fabricate a jumper wire that will connect between **X-093** pin 1 and **X-093** pin 2.

Connect the jumper wire between **X-093** pin 1 and **X-093** pin 2.

Turn the ignition switch ON.

Access the fault code screen on the EST.

Fault code 5153 should no longer be active. Fault code 5152 is now active.

A. Fault code 5153 is no longer active. Fault code 5152 is now active. Temporarily replace the solenoid and retest. Return to step 1 to confirm elimination of the fault.

B. Fault code 5153 is still present and active. Fault code 5152 did not become active. Temporarily replace the **UCM** and retest. Return to step 1 to confirm elimination of the fault.

**Harnesses and connectors - Electrical schematic sheet 25 (55.100-C.20.E.25)**

**Harnesses and connectors - Electrical schematic sheet 08 (55.100-C.20.E.08)**

## 5174-Ripper Lower Solenoid High Side Shorted to Power or Open Circuit

### Context:

The UCM detects an unusually low current draw in the ripper down solenoid circuit, **X-021** pin 13. The ripper and winch are disabled while fault code 5174 is active.

### Cause:

There is an unusually low current draw or an open circuit in the ripper down solenoid circuit, **X-021** pin 13.

### Possible failure modes:

1. Faulty wiring or connections.
2. Open circuit in the ripper down solenoid circuit.
3. Faulty ripper down solenoid.
4. Faulty UCM.

### Solution:

1. Verify that the fault code is active.

Connect the Electronic Service Tool to the service tool connector.

To check for fault codes: Start and operate the machine.

A. The fault code is not recorded again. OK to return the machine to service.

B. Fault code 5174 is recorded again. Go to step 2.

2. Verify that the wiring and connectors are free of damage.

Inspect the **UCM** and the ripper down solenoid connections. All connections should be secure, tight, free of corrosion, abrasion and damage.

Inspect the harness from the **UCM** to the ripper down solenoid. Verify that the harness is free of damage, corrosion, abrasion and incorrect attachment.

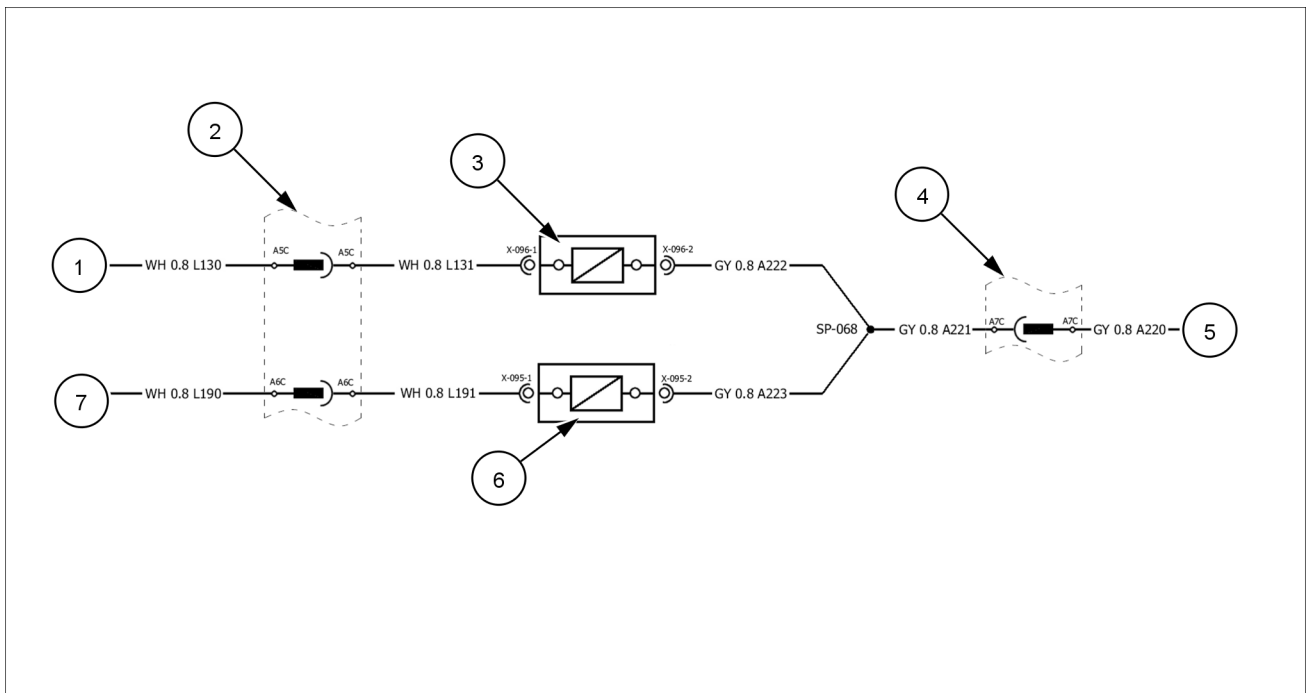

RAIL12DOZ0238FA 1

## 5194-Implement Enable Valve Shorted to Power or Open Circuit

### Context:

The UCM detects an unusually low current draw in the implement interlock solenoid circuit, **X-019** pin 18. Implement hydraulics are disabled while fault code 5194 is active.

### Cause:

There is an unusually low current draw or an open circuit in the implement interlock solenoid circuit, **X-019** pin 18.

### Possible failure modes:

1. Faulty wiring or connections.
2. Open circuit in the implement interlock solenoid circuit.
3. Faulty implement interlock solenoid.
4. Faulty UCM.

### Solution:

1. Verify that the fault code is active.

Connect the Electronic Service Tool to the service tool connector.

To check for fault codes: Start and operate the machine.

A. The fault code is not recorded again. OK to return the machine to service.

B. Fault code 5194 is recorded again. Go to step **2**.

2. Verify that the wiring and connectors are free of damage.

Inspect the **UCM** and the implement interlock solenoid connections. All connections should be secure, tight, free of corrosion, abrasion and damage.

Inspect the harness from the **UCM** to the implement interlock solenoid. Verify that the harness is free of damage, corrosion, abrasion and incorrect attachment.

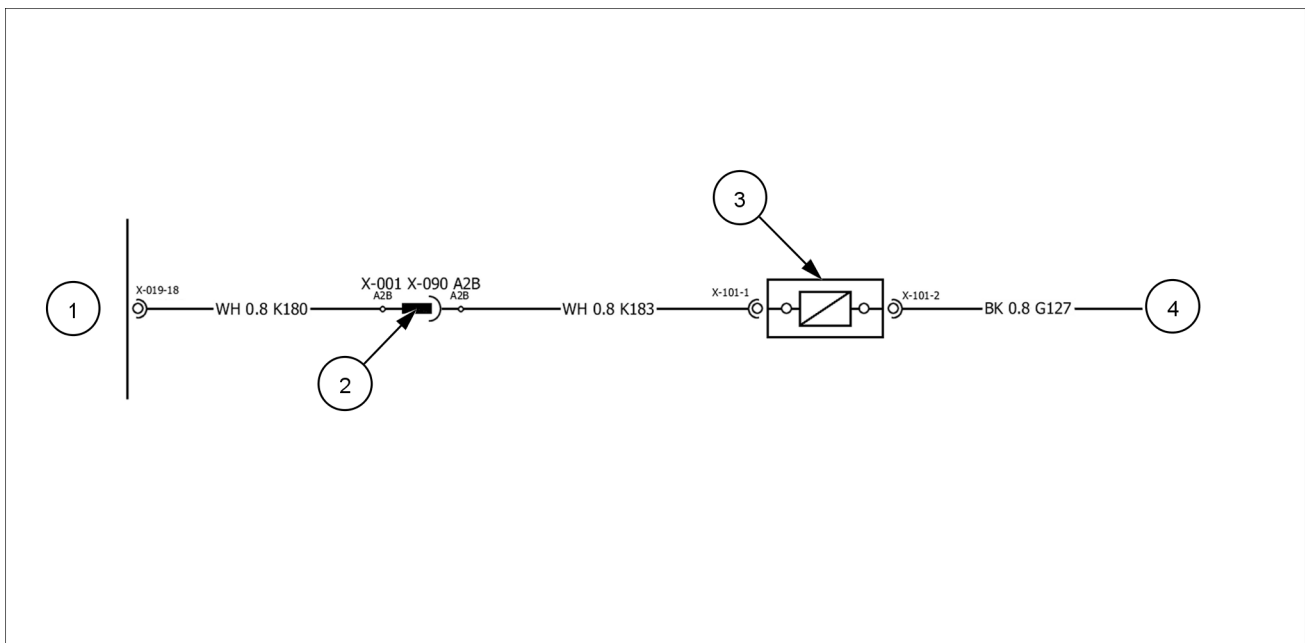

RAIL12DOZ0159FA 1

## 5313-Blade Tilt Solenoids Return Shorted to Power

### Context:

The UCM detects a short circuit to another voltage source in the blade tilt right/left solenoid return circuit, **X-015** pin 30. Blade tilt operation will be disabled while fault code 5313 is active.

### Cause:

There is a short circuit to another voltage source in the blade tilt right/left solenoid return circuit, **X-015** pin 30.

### Possible failure modes:

1. Short circuit in the blade tilt right/left solenoid ground circuit.
2. Faulty blade tilt right solenoid and blade tilt left solenoid.
3. Faulty UCM.

### Solution:

1. Verify that the fault code is active.

Connect the Electronic Service Tool to the service tool connector.

To check for fault codes: Start and operate the machine.

A. The fault code is not recorded again. OK to return the machine to service.

B. Fault code 5313 is recorded again. Go to step 2.

2. Verify that the wiring and connectors are free of damage.

Inspect the **UCM**, the blade tilt right solenoid, and the blade tilt left solenoid connections. All connections should be secure, tight, free of corrosion, abrasion and damage.

Inspect the harness from the **UCM** to the blade tilt right solenoid and the blade tilt left solenoid. Verify that the harness is free of damage, corrosion, abrasion and incorrect attachment.

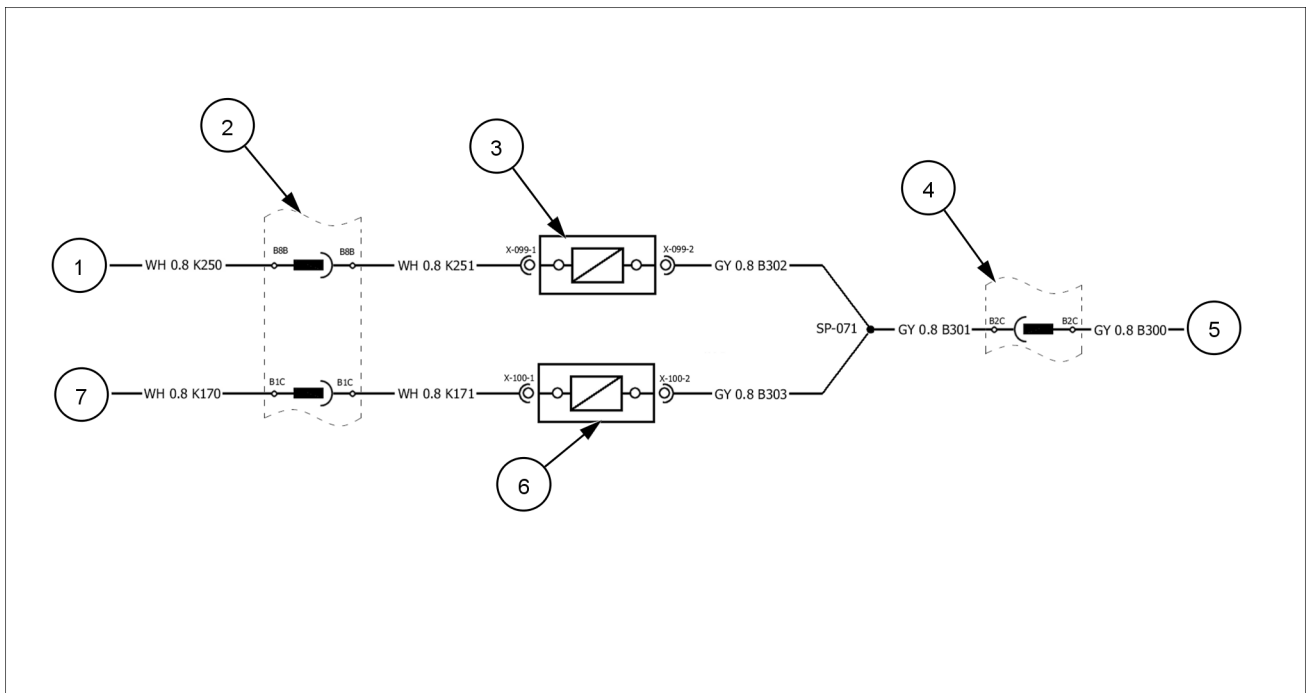

RAIL12DOZ0237FA 1

Schematic legend			
(1)	Unswitched battery <b>24 V</b>	(4)	Winch ground <b>GND-MAIN</b>
(2)	Winch relay signal from winch relay <b>K-007</b> pin 87	(5)	<b>UCM</b> connector <b>X-018</b> Pin 5, Winch high side drive signal
(3)	Connector <b>X-010 X-034</b>	(6)	<b>UCM</b> connector <b>X-019</b> Pin 4, Winch low side drive signal

A. The connectors are secure and the harness is free of damage. Go to step **3**.

B. The connectors or the harness has damage. Repair or replace the harness or connectors as required. Return to step **1** to confirm elimination of fault.

3. Measure the resistance through the circuit.

Turn the ignition switch OFF.

Disconnect connector **X-010 X-034** .

Measure the resistance between **X-034** pin F and **X-034** pin H. The resistance should be less than **5,000 Ω**. Wiggle the harness during measurement to reveal an intermittent condition.

A. The resistance is less than **5,000 Ω**. Go to step **4**.

B. The resistance is greater than **5,000 Ω**, there is an open circuit in the wiring or the winch solenoid. Repair as required. Return to step **1** to confirm elimination of fault.

4. Measure the resistance through the circuit.

Turn the ignition switch OFF.

Disconnect the connector **X-010 X-034**.

Fabricate a jumper wire that will connect between **X-010** pin F and **X-010** pin H.

Connect the jumper wire between **X-010** pin F and **X-010** pin H.

Disconnect UCM connectors **X-018** and **X-019**.

Measure the resistance between **X-018** pin 5 and **X-019** pin 4. Wiggle the harness during measurement to reveal an intermittent condition. The resistance should be less than **10 Ω**.

A. The resistance is greater than **10 Ω**. There is an open circuit in the wiring. Repair as required. Return to step **1** to confirm elimination of the fault.

B. The resistance is less than **10 Ω**. There is a problem with the **UCM**. Temporarily replace the **UCM** and retest. Return to step **1** to confirm elimination of the fault.

**Harnesses and connectors - Electrical schematic sheet 07 (55.100-C.20.E.07)**

**Harnesses and connectors - Electrical schematic sheet 08 (55.100-C.20.E.08)**

Schematic legend			
(1)	Blade control Connector <b>X-032</b> and <b>X-033</b>	(6)	<b>UCM</b> connector <b>X-014</b> Pin 10, Right joystick L-R 1
(2)	<b>UCM</b> connector <b>X-014</b> Pin 11, Thumbwheel 1	(7)	<b>UCM</b> connector <b>X-014</b> Pin 16, Right joystick L-R 2
(3)	<b>UCM</b> connector <b>X-014</b> Pin 18, Thumbwheel 2	(8)	<b>UCM</b> connector <b>X-017</b> Pin 20, Leveling up/AIC command
(4)	<b>UCM</b> connector <b>X-014</b> Pin 17, Right joystick F-B 1	(9)	<b>UCM</b> connector <b>X-017</b> Pin 15, Leveling down/grading
(5)	<b>UCM</b> connector <b>X-014</b> Pin 5, Right joystick F-B 2	(10)	<b>UCM</b> connector <b>X-017</b> Pin 23, Auto/manual/blade shake

A. The connectors are secure and the harness is free of damage. Go to step 3.

B. The connectors or the harness has damage. Repair or replace the harness or connectors as required. Return to step 1 to confirm elimination of fault.

3. Measure the voltage on the signal wire.

Turn the ignition switch OFF.

Disconnect **UCM** connector **X-014**.

Disconnect joystick connector **X-032**.

Turn the ignition switch ON.

Measure the voltage between **UCM** connector **X-014** pin 5 and chassis ground. The chassis ground connection must be clean and free of paint, oil, and dirt. The voltage should be less than **0.5 V**. Wiggle the harness during measurement to reveal an intermittent condition.

A. The voltage is less than **0.5 V**. Go to step 4.

B. The voltage is greater than **0.5 V**. There is a short circuit to another voltage source. Repair or replace the wiring harness as required. Return to step 1 to confirm elimination of the fault.

4. Test the UCM.

Turn the ignition switch OFF.

Reconnect joystick connector **X-032**.

Leave UCM connector **X-014** disconnected.

Remove the wire **A050 WH** from **X-014** pin 5.

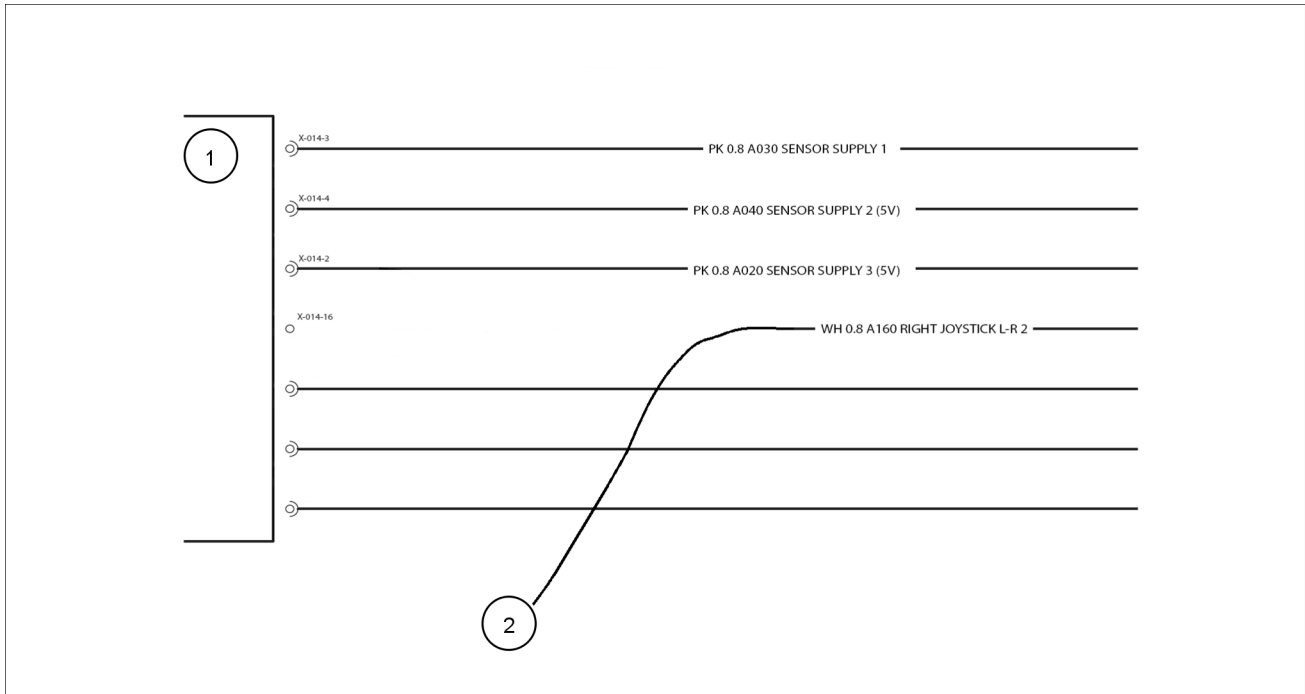

RAIL12DOZ0445FA 2

Schematic legend			
(1)	UCM connector <b>X-014</b>	(2)	Wire <b>WH A160</b> removed from connector <b>X-014</b> Pin 16

Reconnect UCM connector **X-014**.

Turn the ignition switch ON. Access the EST fault code screen.

Fault code 5533 should no longer be active. Fault code 5531 is now active.

A. Fault code 5533 is no longer active. Fault code 5531 is now active. Temporarily replace the joystick and retest. Return to step 1 to confirm elimination of the fault.

B. Fault code 5533 is still present and active. Fault code 5531 did not become active. Temporarily replace the **UCM** and retest. Return to step 1 to confirm elimination of the fault.

**Harnesses and connectors - Electrical schematic sheet 09 (55.100-C.20.E.09)**

**Harnesses and connectors - Electrical schematic sheet 24 (55.100-C.20.E.24)**

## 5561-Aux Axis-1 Shorted to Ground or Open Circuit

### Context:

The **UCM** detects a short to ground or an open circuit in the ripper joystick 1 signal, **X-014** pin 8.

### Cause:

The **UCM** detects a short to ground or an open circuit in the ripper joystick 1 signal, **X-014** pin 8.

### Possible failure modes:

1. A short circuit in the ripper joystick 1 signal.
2. An open circuit in the ripper joystick 1 signal.
3. Faulty joystick.
4. Faulty UCM.

### Solution:

1. Verify that the fault code is active.

Connect the Electronic Service Tool to the service tool connector.

To check for fault codes: Start and operate the machine.

A. The fault code is not recorded again. OK to return the machine to service.

B. Fault code 5561 is recorded again. Go to step 2.

2. Verify that the wiring and connectors are free of damage.

Inspect the **UCM** and the ripper joystick connections. All connections should be secure, tight, free of corrosion, abrasion and damage.

Inspect the harness from the **UCM** to the ripper joystick. Verify that the harness is free of damage, corrosion, abrasion and incorrect attachment.

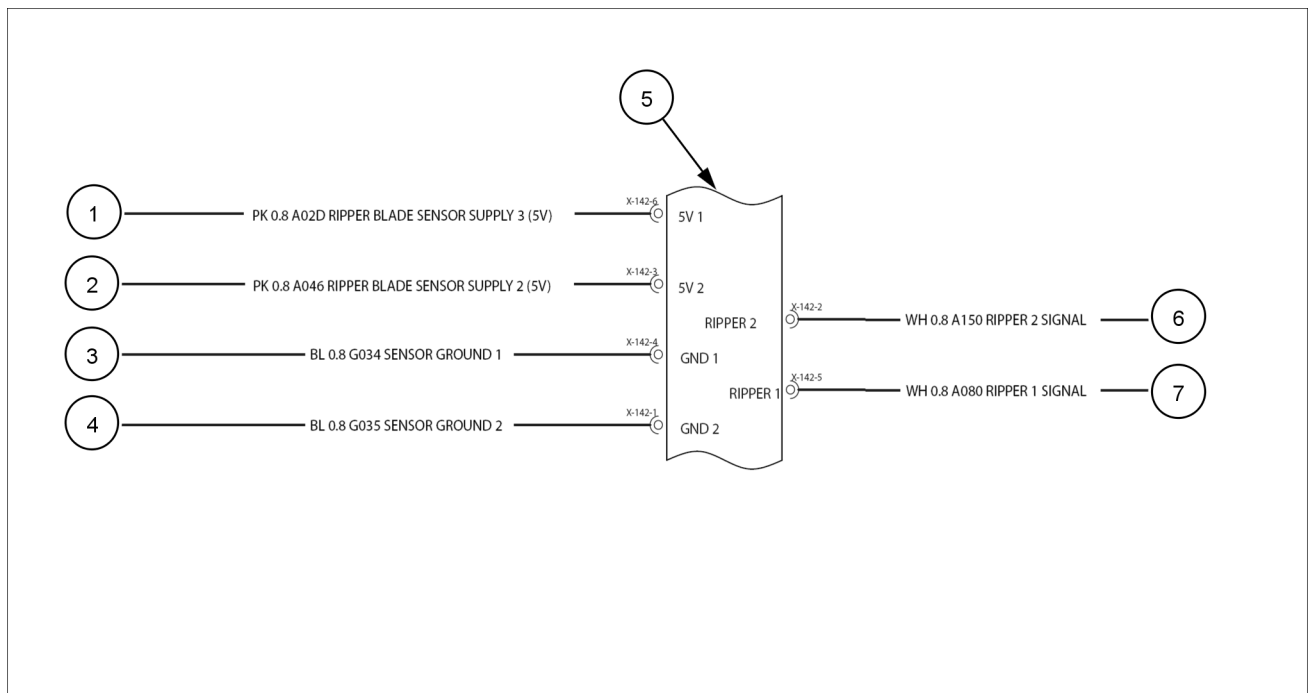

RAIL12DOZ0534FA 1

6. Test the switch.

Turn the ignition switch OFF.

Disconnect the harness and remove the implement enable switch from the panel.

Set the implement enable switch to the OFF position.

Measure the resistance between X-056 pin 2 and X-056 pin 3. The resistance should be less than **10 Ω**.

Measure the resistance between X-056 pin 2 and X-056 pin 1. The resistance should be greater than **20,000 Ω**.

Set the implement enable switch to the ON position.

Measure the resistance between X-056 pin 2 and X-056 pin 3. The resistance should be greater than **20,000 Ω**.

Measure the resistance between X-056 pin 2 and X-056 pin 1. The resistance should be less than **10 Ω**.

A. All resistance measurement are correct. Temporarily replace the UCM and retest. Return to step **1** to confirm elimination of the fault.

B. One or more resistance measurements were not correct. Temporarily replace the implement enable switch and retest. Return to step **1** to confirm elimination of fault.

**Harnesses and connectors - Electrical schematic sheet 09 (55.100-C.20.E.09)**

**Harnesses and connectors - Electrical schematic sheet 19 (55.100-C.20.E.19)**

---

## **8037-CAN Communication Timeout - Leveling Blade Tilt Command CAN Message Rate Inconsistent**

### **Context:**

CAN bus communications between the UCM and the lazer guide system module have been lost. This fault code may be displayed with other CAN bus faults.

The lazer guide system will switch into manual mode while Diagnostic Trouble Code 8027 is active.

### **Cause:**

The UCM did not receive PGN 65074 for a period greater than **1 s**. CAN bus communications between the UCM and the lazer guide system module have been lost.

### **Possible failure modes:**

1. An open circuit in the CAN bus wiring or circuits.
2. A short circuit in the CAN bus wiring or circuits.
3. Faulty lazer guide system module.
4. Faulty UCM.

### **Solution:**

1. Verify that the fault code is active.

Connect the Electronic Service Tool to the service tool connector.

To check for fault codes: Start and operate the machine.

Continue with this procedure if fault code 8027 and 8037 are active. This is an indication of a problem in the CAN Data Link circuit.

If one fault code is active, check all CAN bus wires and connectors to verify they are secure and free of damage, corrosion, abrasion and incorrect attachment. This is an indication of an intermittent connection in the CAN bus.

A. CAN bus fault code 8037 is active. No other CAN Bus codes are active at the time. Check all CAN bus wires and connectors to verify they are secure and free of damage, corrosion, abrasion and incorrect attachment.

B. CAN bus fault codes 8027 and 8037 are present and active. Continue with **8027-CAN Communication Timeout - Leveling Blade Lift-Lower Command CAN Message Rate Inconsistent (55.953)**

**Harnesses and connectors - Electrical schematic sheet 28 (55.100-C.20.E.28)**

# Contents

---

## Tools - 89

### Ripper assembly - 128

#### SERVICE

##### Ripper

Remove ..... 3

Install ..... 6

##### Ripper tool

Remove ..... 9

Install ..... 10

## Cab - Remove

1. Remove the rear cover from the machine. See **Cab outer panel - Remove (90.150)**.
2. Remove six cab floor mat mounting bracket screws (1) and two cab floor mounting brackets (2). Remove the cab floor mat (3) from the machine.

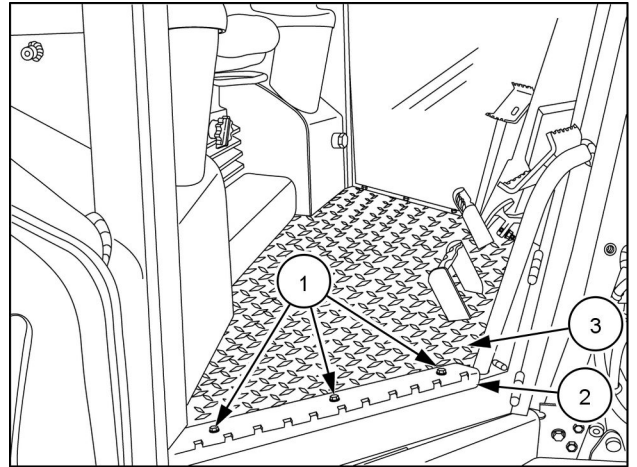

RAIL14DOZ0239AA 1

3. Remove three floor access panel mounting bolts and washers from the floor access panel and remove the floor access panel from the machine.

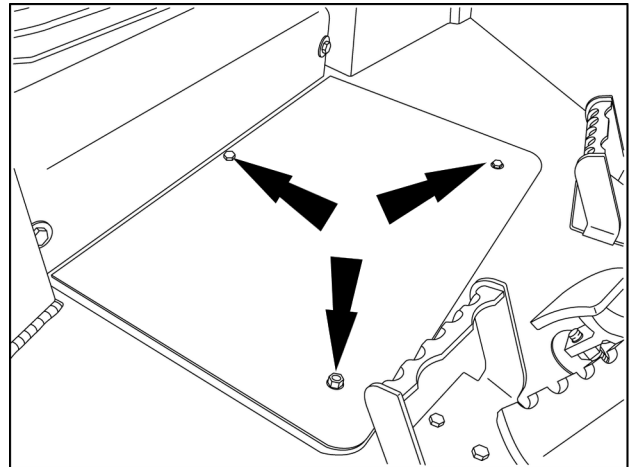

RAIL13DOZ0331AA 2

4. Disconnect the Telematic antenna harness (1) from the machine. Note the location and quantity of wire ties (2) removed to aid in installation.

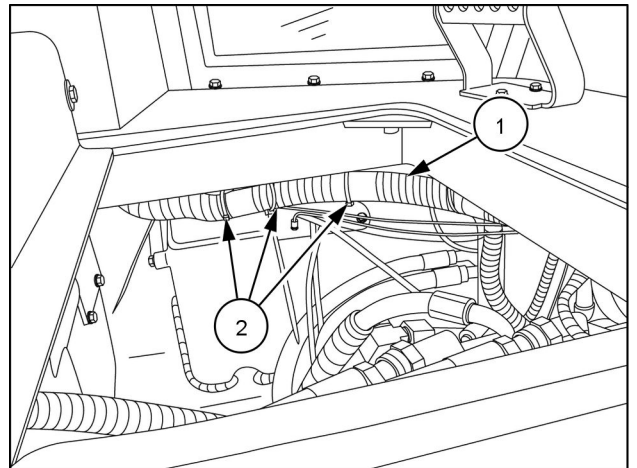

RAIL14DOZ0251AA 3

CLICK HERE TO **DOWNLOAD** THE COMPLETE MANUAL

- Thank you very much for reading the preview of the manual.
- You can download the complete manual from: [www.heydownloads.com](http://www.heydownloads.com) by clicking the link below



- Please note: If there is no response to CLICKING the link, please download this PDF first and then click on it.

CLICK HERE TO **DOWNLOAD** THE COMPLETE MANUAL