

SHOP MANUAL

KOMATSU D475A-3

MACHINE MODEL SERIAL No.

D475A-3 **10601 and up**

- This shop manual may contain attachments and optional equipment that are not available in your area. Please consult your local Komatsu distributor for those items you may require. Materials and specifications are subject to change without notice.
- D475A-3 mount the SDA12V140-1 engine.
For details of the engine, see the 12V140-1 Series Engine Shop Manual.

CLICK HERE TO **DOWNLOAD** THE COMPLETE MANUAL

- Thank you very much for reading the preview of the manual.
- You can download the complete manual from: www.heydownloads.com by clicking the link below



- Please note: If there is no response to CLICKING the link, please download this PDF first and then click on it.

CLICK HERE TO **DOWNLOAD** THE COMPLETE MANUAL

FOREWORD

GENERAL

This shop manual has been prepared as an aid to improve the quality of repairs by giving the serviceman an accurate understanding of the product and by showing him the correct way to perform repairs and make judgments. Make sure you understand the contents of this manual and use it to full effect at every opportunity.

This shop manual mainly contains the necessary technical information for operations performed in a service workshop. For ease of understanding, the manual is divided into the following chapters; these chapters are further divided into the each main group of components.

STRUCTURE AND FUNCTION

This section explains the structure and function of each component. It serves not only to give an understanding of the structure, but also serves as reference material for troubleshooting.

In addition, this section may contain hydraulic circuit diagrams, electric circuit diagrams, and maintenance standards.

TESTING AND ADJUSTING

This section explains checks to be made before and after performing repairs, as well as adjustments to be made at completion of the checks and repairs.

Troubleshooting charts correlating "Problems" with "Causes" are also included in this section.

DISASSEMBLY AND ASSEMBLY

This section explains the procedures for removing, installing, disassembling and assembling each component, as well as precautions for them.

MAINTENANCE STANDARD

This section gives the judgment standards for inspection of disassembled parts.

The contents of this section may be described in STRUCTURE AND FUNCTION.

OTHERS

This section mainly gives hydraulic circuit diagrams and electric circuit diagrams.

In addition, this section may give the specifications of attachments and options together.

NOTICE

The specifications contained in this shop manual are subject to change at any time and without any advance notice. Use the specifications given in the book with the latest date.

ELECTRIC WIRE CODE

In the wiring diagrams, various colors and symbols are employed to indicate the thickness of wires. This wire code table will help you understand WIRING DIAGRAMS.

Example: 5WB indicates a cable having a nominal number 5 and white coating with black stripe.

CLASSIFICATION BY THICKNESS

Nominal number	Copper wire			Cable O.D. (mm)	Current rating (A)	Applicable circuit
	Number of strands	Dia. of strands (mm ²)	Cross section (mm ²)			
0.85	11	0.32	0.88	2.4	12	Starting, lighting, signal etc.
2	26	0.32	2.09	3.1	20	Lighting, signal etc.
5	65	0.32	5.23	4.6	37	Charging and signal
15	84	0.45	13.36	7.0	59	Starting (Glow plug)
40	85	0.80	42.73	11.4	135	Starting
60	127	0.80	63.84	13.6	178	Starting
100	217	0.80	109.1	17.6	230	Starting

CLASSIFICATION BY COLOR AND CODE

Priority	Classification	Circuits	Charging	Ground	Starting	Lighting	Instrument	Signal	Other
			Code	Color	Code	Color	Code	Color	Code
1	Primary	Code	W	B	B	R	Y	G	L
		Color	White	Black	Black	Red	Yellow	Green	Blue
2	Auxiliary	Code	WR	—	BW	RW	YR	GW	LW
		Color	White & Red	—	White & Black	Red & White	Yellow & Red	Green & White	Blue & White
Code		WB	—	BY	RB	YB	GR	LR	
Color		White & Black	—	Black & Yellow	Red & Black	Yellow & Black	Green & Red	Blue & Yellow	
Code		WL	—	BR	RY	YG	GY	LY	
Color		White & Blue	—	Black & Red	Red & Yellow	Yellow & Green	Green & Yellow	Blue & Yellow	
Code		WG	—	—	RG	YL	GB	LB	
Color		White & Green	—	—	Red & Green	Yellow & Blue	Green & Black	Blue & Black	
6		Code	—	—	—	RL	YW	GL	—
		Color	—	—	—	Red & Blue	Yellow & White	Green & Blue	—

• SUPER DOZER + COUNTERWEIGHT

Unit: mm

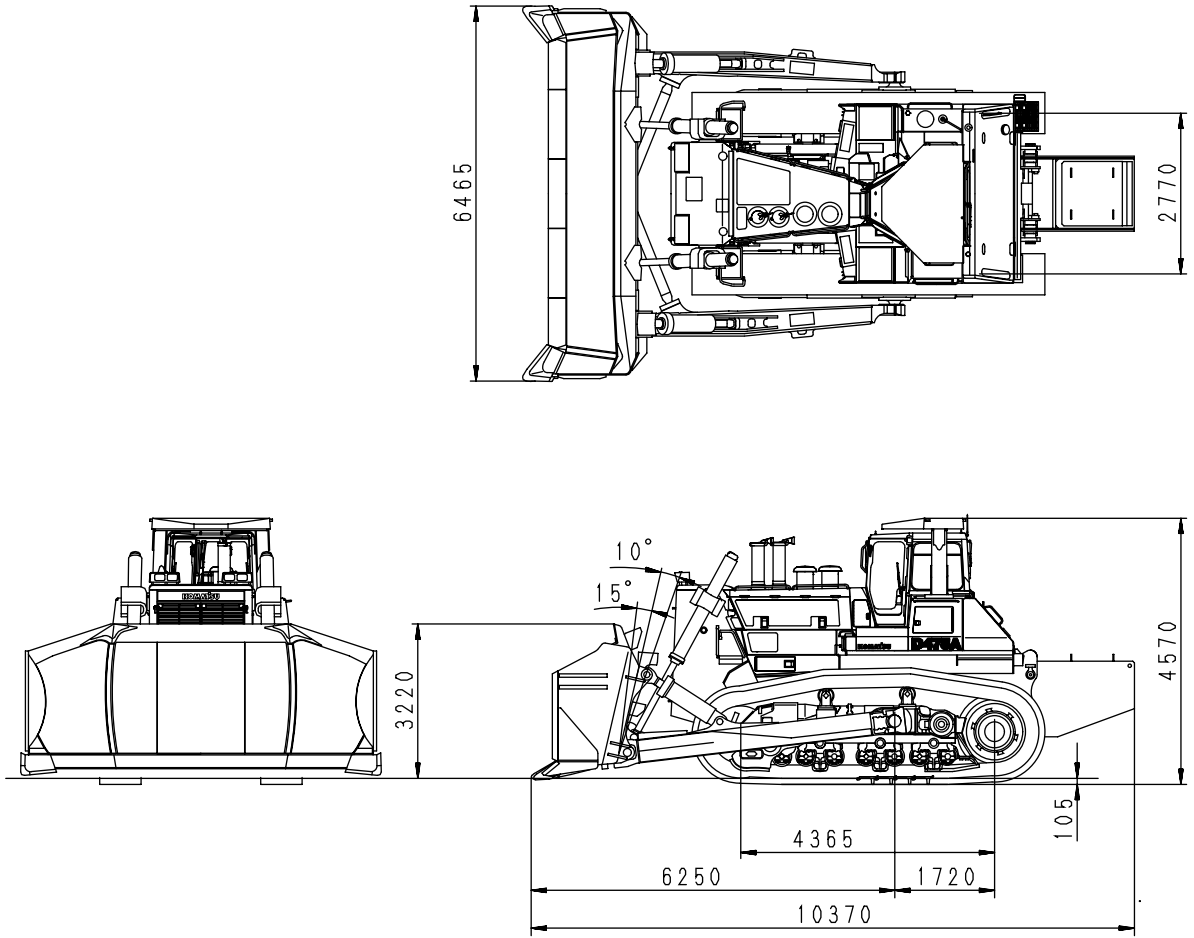

SWD03130

WEIGHT TABLE

 This weight table is a guide for use when transporting or when handling components.

• **SEMI U-TILTDOZER, U-TILTDOZER**

Unit: kg

Machine model	D475A-3	
	10601 – 10684	10685 and up
Engine, damper assembly	3,940	
• Engine assembly	3,740	
• Damper assembly	214	
Main radiator assembly	528	
Sub. radiator assembly	162	
Oil cooler assembly	157	
Fuel tank assembly (when full)	858 (2,330)	
Power train unit	4,980	
• Torque converter, PTO assembly	750	
• Transmission assembly	1,350	
• Transmission valve assembly	70	
• Steering clutch, brake assembly	2,290	
• Steering valve assembly	26	
Final drive assembly (each side)	3,575	
Main frame assembly	9,120	
Track group assembly (each side)	11,050	11,180
• Track frame (each side)	2,988	2,996
• Idler assembly (each side)	664	708
• Track roller assembly (single, each)	—	222
• Track roller assembly (double, each)	214	237
• Carrier roller assembly (each)	102	106
Track shoe assembly (710 mm width)	12,940	13,220
Pivot shaft assembly (each side)	370	370
Equalizer bar	598	598
Hydraulic tank assembly	498	
• Main control valve (blade lift)	69	
• Main control valve (blade tilt, ripper)	46	

★ The figures in () show the dimensions for the U-blade.

POWER TRAIN SKELETON

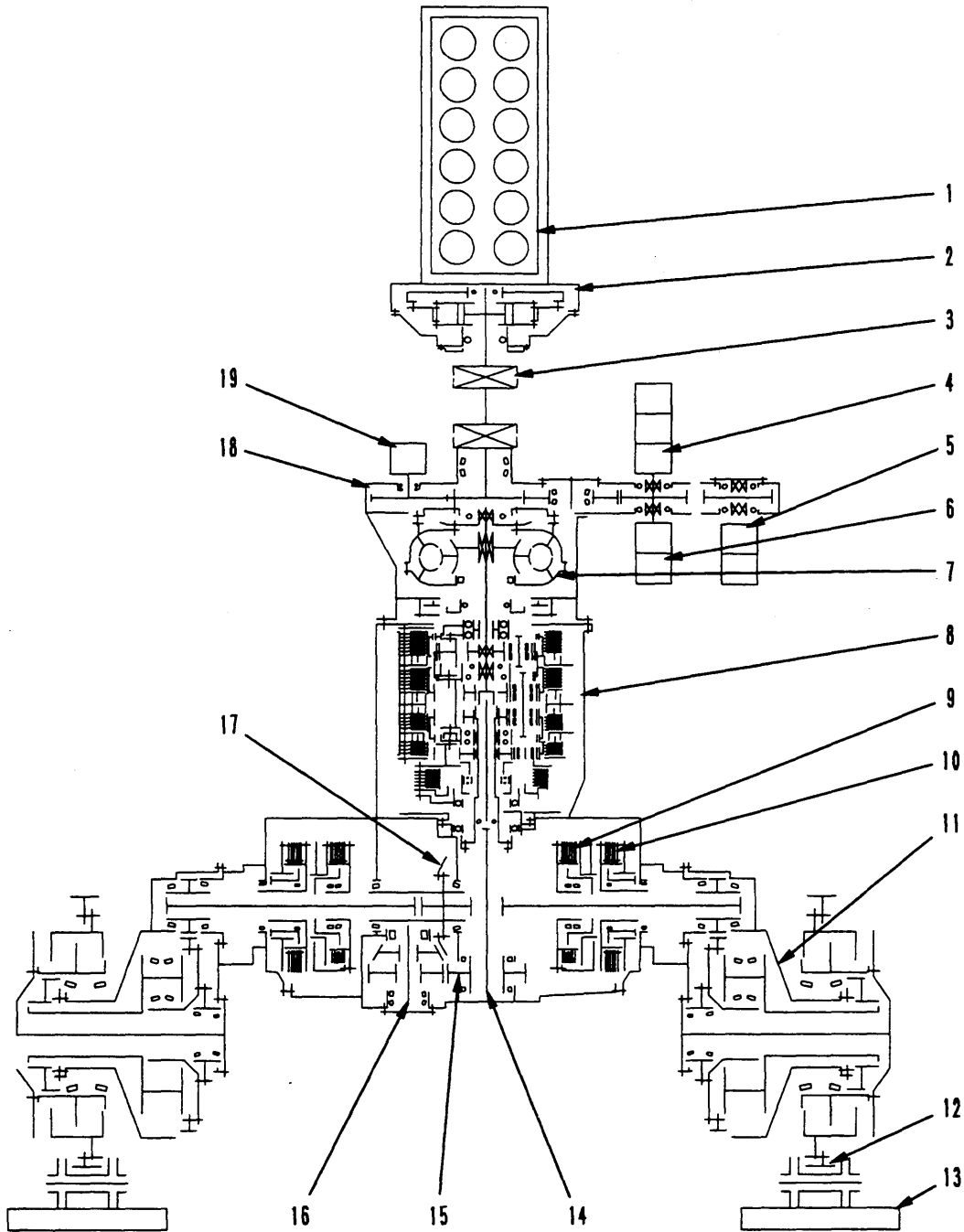

SV002962

- | | | | |
|--|-------------------------------|-------------------------|---------------------|
| 1. Engine (SDA12V140) | 6. Hydraulic pump (SAR100+32) | 11. Final drive | 17. Bevel gear |
| 2. Damper | 7. Torque converter | 12. Sprocket | 18. PTO |
| 3. Universal joint | 8. Transmission | 13. Track shoe | 19. Scavenging pump |
| 4. Power train, hydraulic, lubricating pump (BAL160+112+112) | 9. Steering clutch | 14. Transfer | |
| 5. Hydraulic pump (SAL140+100) | 10. Steering brake | 15. Transfer drive gear | |
| | 16. Bevel pinion | | |

TORQUE CONVERTER VALVE

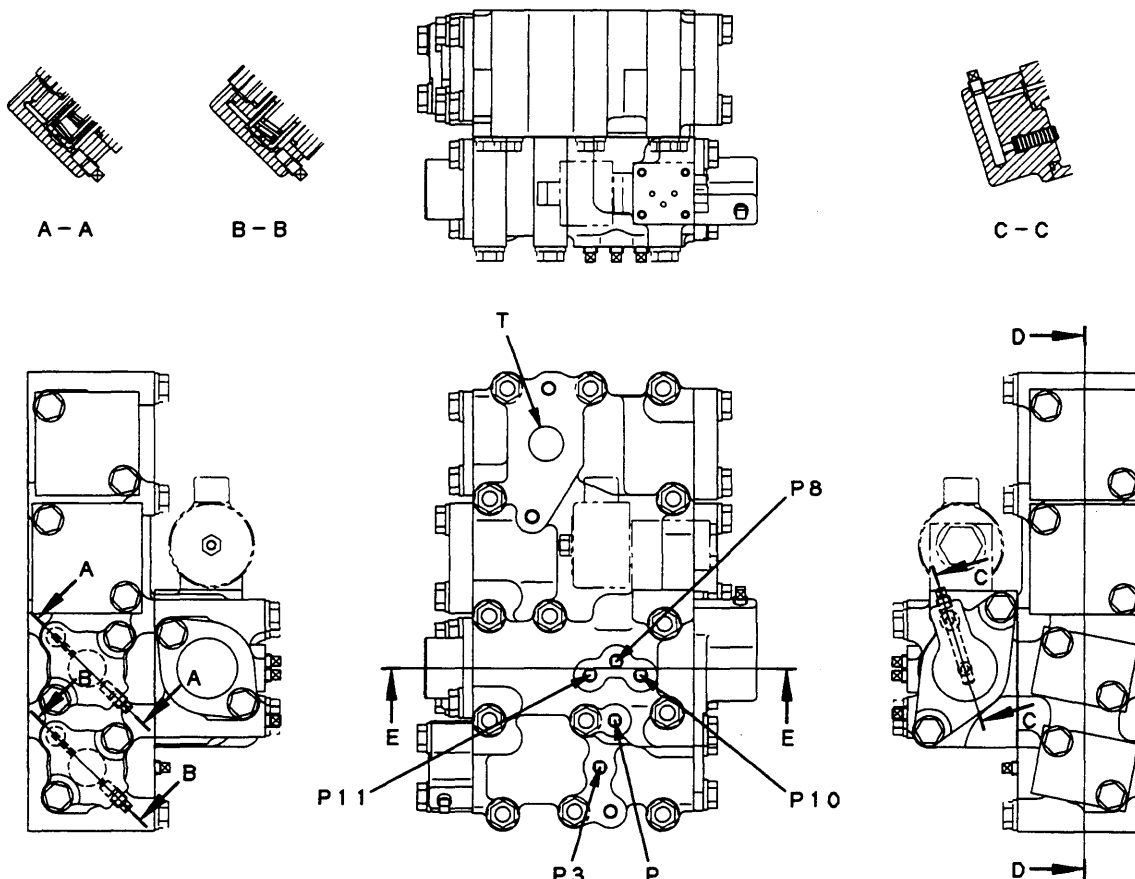

SJ002970

- 1. Valve body
- 2. Torque converter relief valve
- 3. Valve spring
- 4. Valve spring
- 5. Main relief valve
- 6. Cover
- 7. Piston
- 8. Piston spring
- 9. Piston
- 10. Stator clutch modulating valve
- 11. Lock-up clutch modulating valve
- 12. Cover
- 13. Piston
- 14. Piston spring (Small)
- 15. Piston

- 16. Valve spring (Outer)
- 17. Valve spring (Inner)
- 18. Stopper
- 19. Load piston
- 20. Cover
- 21. Cover
- 22. Valve spring
- 23. Valve body
- 24. Lock-up selector valve
- 25. Piston
- 26. Cover
- Lock-up solenoid valve assembly**
- 27. Cover
- 28. Coil
- 29. Spring
- 30. Plunger
- 31. Valve seat holder

- 32. Valve seat
- 33. Spring
- 34. Valve seat
- 35. Cap

- P. Stator clutch pressure pickup port
- P3. Lock-up clutch pressure pickup port
- P8. Main relief pressure pickup port
- P10. Lock-up clutch initial pressure pickup port
- P11. Stator clutch initial pressure pickup port
- T. From torque converter pump

5. Front cover
6. Sun gear for REVERSE (32 teeth)
7. Ring gear for REVERSE (89 teeth)
8. Pinion shaft
9. Planet pinion for REVERSE (25 teeth)
10. Ring gear for REVERSE (82 teeth)
11. Pinion shaft
12. Ring gear for FORWARD (89 teeth)
13. Planet pinion for FORWARD (25 teeth)
14. Sun gear for FORWARD (39 teeth)
15. Ring gear for 3rd (89 teeth)
16. Planet pinion for 3rd (25 teeth)
17. Sun gear for 3rd (39 teeth)
18. Ring gear for 2nd (89 teeth)
19. Planet pinion for 2nd (21 teeth)
20. Pinion shaft
21. Sun gear for 2nd (47 teeth)
22. Carrier for 2nd
23. 1st clutch inner drum
24. 1st clutch piston
25. 1st clutch piston housing
26. Output shaft
27. Collar
28. Drive shaft (for sensor)
29. 2nd clutch piston
30. Piston housing for 2nd
31. Carrier for FORWARD, 3rd
32. 3rd clutch piston
33. Piston housing for FORWARD, 3rd
34. Clutch piston for FORWARD
35. Carrier for REVERSE
36. Piston housing for REVERSE
37. REVERSE clutch piston
38. Tie rod pin
39. Clutch spring
40. Washer spring
41. Clutch disc
42. Tie bolt
43. Clutch plate

MODULATING VALVE

OUTLINE

- The modulating valve consists of the modulating valve and quick return valve, and acts to modulate the pressure.
- When the transmission shift lever is operated to change the speed range, the clutch is engaged by the piston, but if high pressure is suddenly applied, the piston will engage the clutch suddenly. This will cause the machine to start moving suddenly and will subject the machine to excessive shock. To avoid this, the modulating valve is installed. When the transmission shift lever is operated to shift the speed range, the modulating valve allows the pressure on the piston to rise slowly to the set pressure so that the clutch can be engaged smoothly and so that there will be no shock when starting. This improves the durability of the power train, and also gives a more comfortable ride.
- The diagram on the right shows the time intervals and the rise in pressure when using the modulating valve.

For example, if the transmission is shifted from F1 to F2, the oil from the pump passes through the speed valve spool to the 2nd clutch and fills the circuit up to the clutch piston port.

The time taken to fill the circuit up to the clutch piston port is called the FILLING TIME; the pressure is 0 – 0.3 MPa {0 – 3 kg/cm²}.

The time taken from the point where the hydraulic pressure starts to rise (after the oil fills the circuit up to the clutch piston port) to the point where it reaches the set pressure is called the BUILD-UP TIME.

The total time for the filling time and build-up time is called the MODULATING TIME.

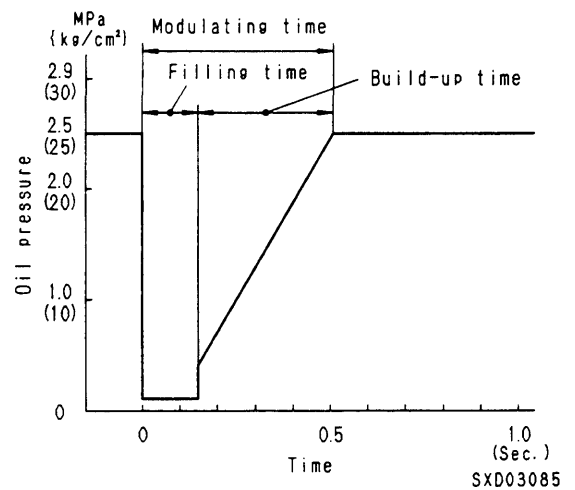

Outline

- The steering control valve is in the circuit between the power train pump (through the main relief valve) and the pistons of the steering clutch and brake. It consists of two sets of steering valves and brake valves.
- If the joystick (steering, directional) is moved to the right or left, the steering clutch is disengaged. If the joystick is moved further, the brake is also applied.
It is possible to adjust between gradual and sharp turning by the amount the joystick is operated.
If the brake pedal is depressed, both the left and right brakes are applied, and the machine will stop.
The above operations are carried out by switching the steering control valve, which is interconnected with the lever and pedal.
The steering control valve sends oil from the power train pump to the steering clutch and brake, and operates each disc clutch.

Valve control

- The steering control valve is operated by left and right steering levers (1) and (3), which are interconnected with the joystick, and parking brake lever (4) and brake lever (2), which are interconnected with the brake pedal.
Left and right steering levers (1) and (3) use a cam to interconnect the steering valve and brake valve inside the steering control valve to carry out control.

TRACK FRAME

Serial No.: 10601 – 10684

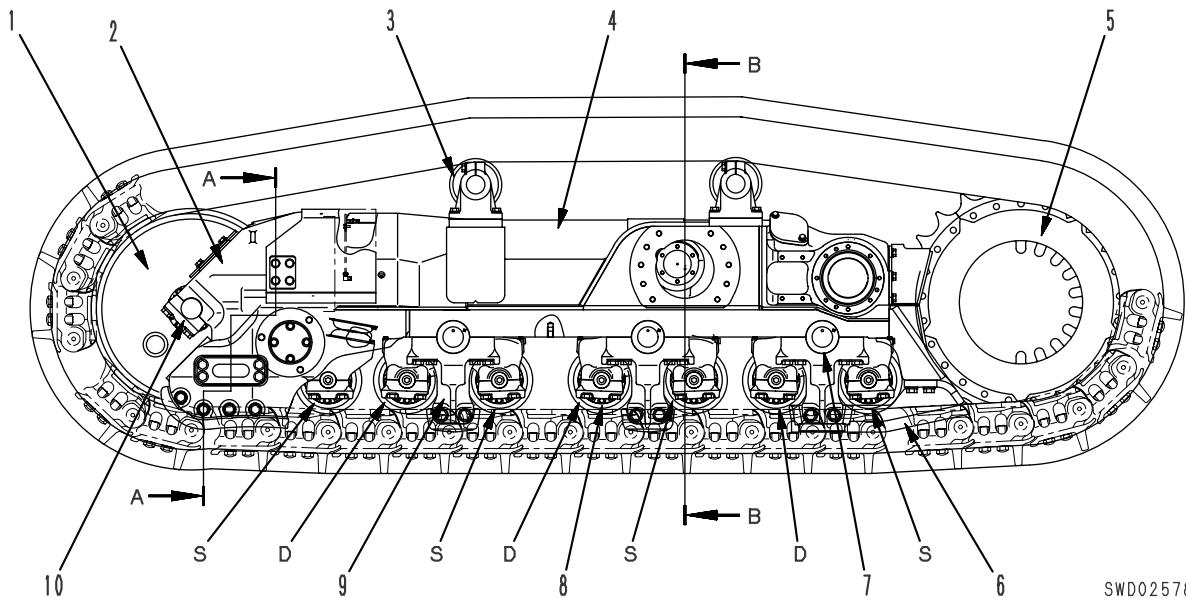
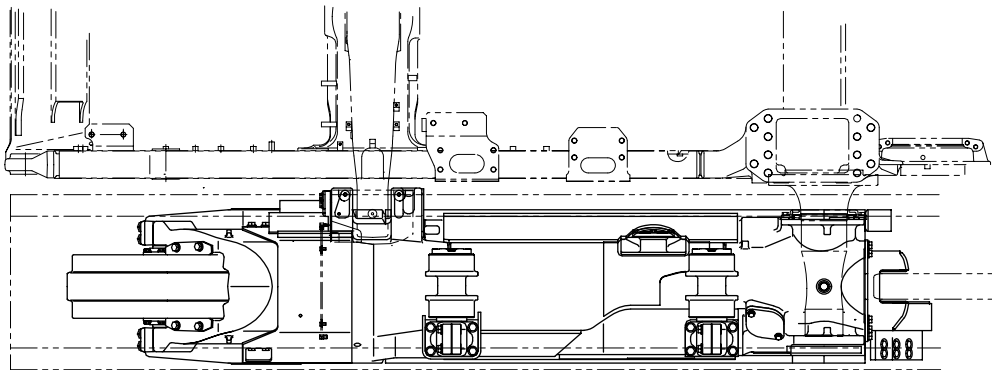

SWD02578

Outline

- The track roller uses an X-shape bogie mount to increase the ground contact area between the track shoe and ground surface on rough surfaces, thereby increasing the drawbar pull.
- The X-shape bogie is fitted with rubber pads to absorb the shock from the ground surface.

Track roller, bogie

	Track roller flange type and bogie arrangement							Applicable
	1st	Inner	Outer	Inner	Outer	Inner	Outer	
Bogie								
Track roller	D	D	D	D	D	D	D	Semi U, U specification
	S	D	S	D	S	D	S	Superdozer specification

3) During fine control

(When control lever is returned)

When disc (5) starts to be returned, spool (1) is pushed up to the force of centering spring (3) and the pressure at port **P1**.

When this happens, notch **f2** for fine control is connected to drain chamber **D**, and the pressure oil at port **P1** is released.

If the pressure at port **P1** drops too far, spool (1) is pushed down by metering spring (2), and notch **f1** for fine control is shut off from drain chamber **D**. At almost the same time it is connected to pump pressure chamber **PP**, and the pump pressure is supplied until the pressure at port **P1** recovers to a pressure that corresponds to the lever position.

When the spool of the control valve returns, oil in drain chamber **D** flows in from notch **f2'** for fine control in the valve on the side that is not working.

The oil passes through port **P2** and enters chamber **PB** to fill the chamber with oil.

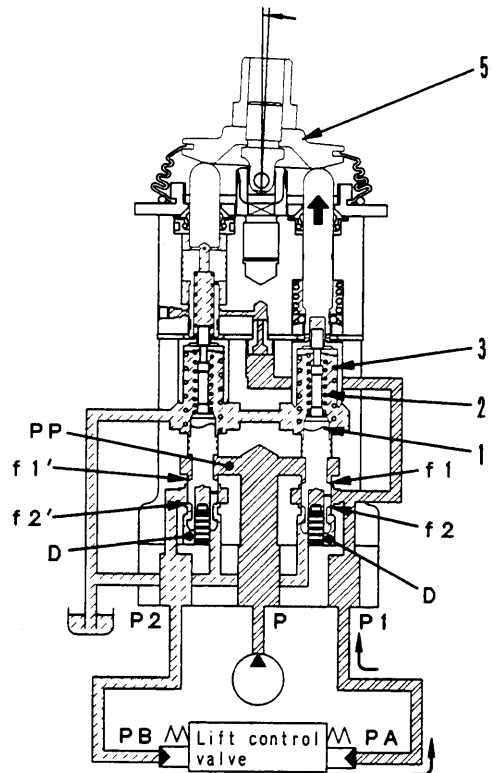

SWD03033

4) At full stroke

When disc (5) pushes down piston (4), and retainer (9) pushes down spool (1), notch **f2** for fine control is shut off from drain chamber **D**, and is connected with pump pressure chamber **PP**.

Therefore, the pilot pressure oil from the charging pump passes through notch **f1** for fine control and flows to chamber **PA** from port **P1**, and pushes the control valve spool. The oil returning from chamber **PB** from port **P2** through notch **f2'** for fine control and flows to drain chamber **D**.

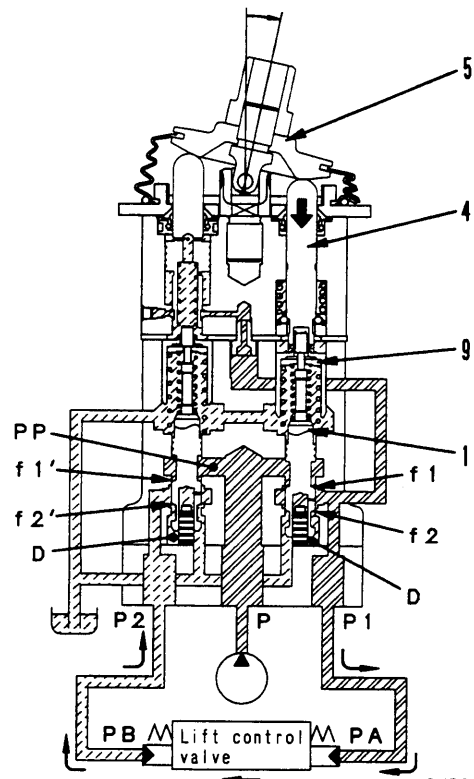

SWD03034

1. Valve body
2. Piston
3. Shuttle valve
4. Shuttle valve spring
5. Plug
6. Valve seat
7. Main relief valve poppet
8. Main relief valve spring
9. Sleeve
10. Main relief pressure adjustment screw

PL. From shuttle valve inside ripper valve
PB. From shuttle valve inside blade lift valve
PD. To demand valve pilot port
T. To hydraulic tank

Outline

- The main relief valve is in the circuit between the hydraulic tank and the ripper circuit and blade lift circuit through shuttle valve (3). The oil pressure in the blade lift circuit, that is, the large pump circuit, is set at 20.6 MPa {210 kg/cm²}.
- The shuttle valve is in the circuit between the demand valve through the main relief valve and the blade lift circuit and ripper circuit. It selects the two circuits to apply the pilot pressure to the demand valve. In other words, it selects either the blade lift circuit or the ripper circuit. When the work equipment is not being used (when the control lever is at neutral) the shuttle valve connects the blade lift circuit and the pilot port of the demand valve by the tension of spring (4).

ENGINE CONTROL SYSTEM

- Items listed for SSC do not apply to superdozer specification machine.

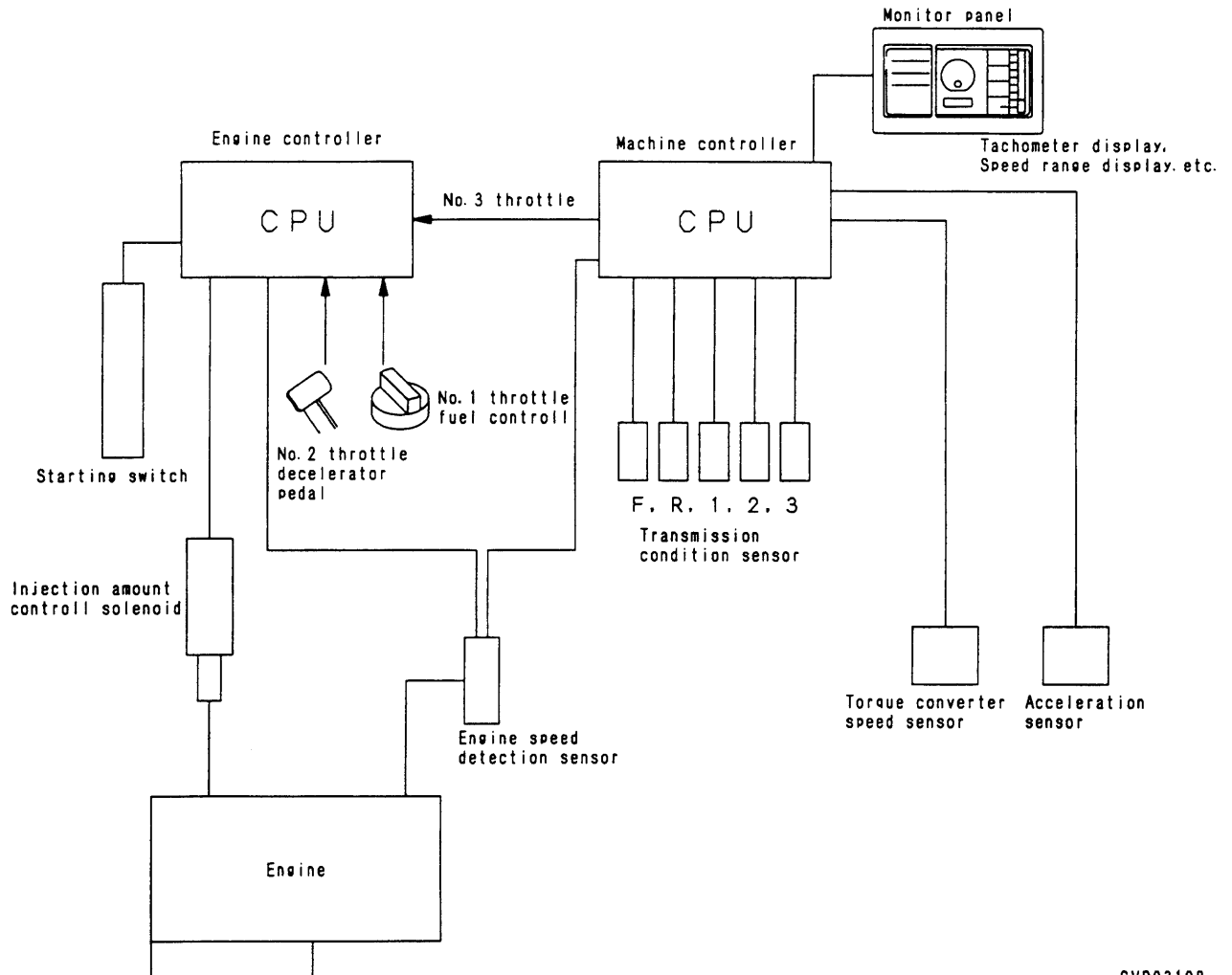

SVD03108

Outline

The engine controller receives the manual signals from the No. 1 throttle and No. 2 throttle, and the No. 3 throttle, which is the control signal from the machine. It selects the lowest engine speed from among these and controls the electronic governor.

The control signal from the No. 3 throttle includes the following.

- (1) High idling speed control
- (2) Shoe slip control
- (3) 3rd auto deceleration

Example:

When the transmission is at neutral, even if the throttle lever is set to the FULL position and the economy mode is selected, the engine speed is automatically set to partial.

MONITOR PANEL FUNCTIONS

- Items listed for SSC do not apply to superdozer specification machine.

1. Monitor panel functions

- Switching lock-up mode ON/OFF
- Setting economy mode to OFF, Mode 1, Mode 2
- Switching REVERSE slow mode ON/OFF
- Switching shoe slip control mode ON/OFF
- Setting shoe slip mode level: Modes 1 – 5

Functions a), b), and c) are mounted on all specifications; functions d) and e) are mounted on the shoe slip control specification machine.

- Shoe slip control specification

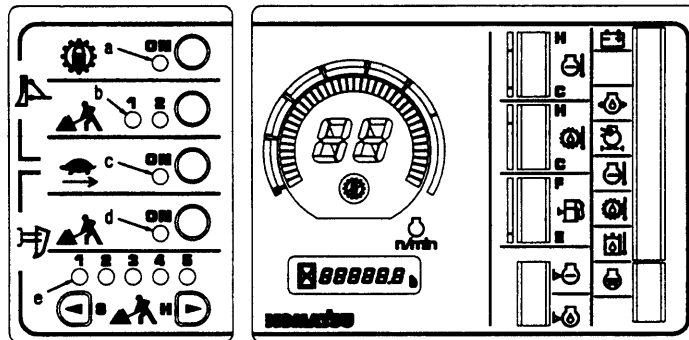

SJD03017

- No shoe slip control

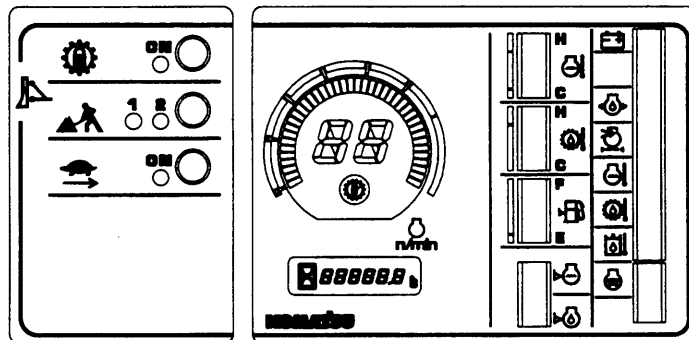

SJD03018

- ★ Economy mode functions: On bedrock or other jobsites where the shoes slip frequently, the power output is set as follows in each mode to reduce the frequency of deceleration operation.
 Economy mode 1: Set to 90% of full power
 Economy mode 2: Set to 70% of full power
 REVERSE slow mode: Set to 80% of full speed when traveling in reverse

2. Default settings when switch is turned ON

- For machines with the superdozer specification, most of the work is carried out with the lock-up ON, so the lock-up mode is selected by default when the starting switch is turned ON.
- For machines with other than the superdozer specification, the operator can select the functions that are best for the jobsite, so all functions are turned OFF by default unless they are selected.

ELECTRICAL EQUIPMENT

RELAY BOX

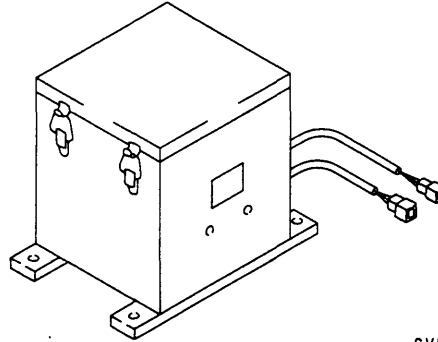

SV003020

RELAY BOX CIRCUIT

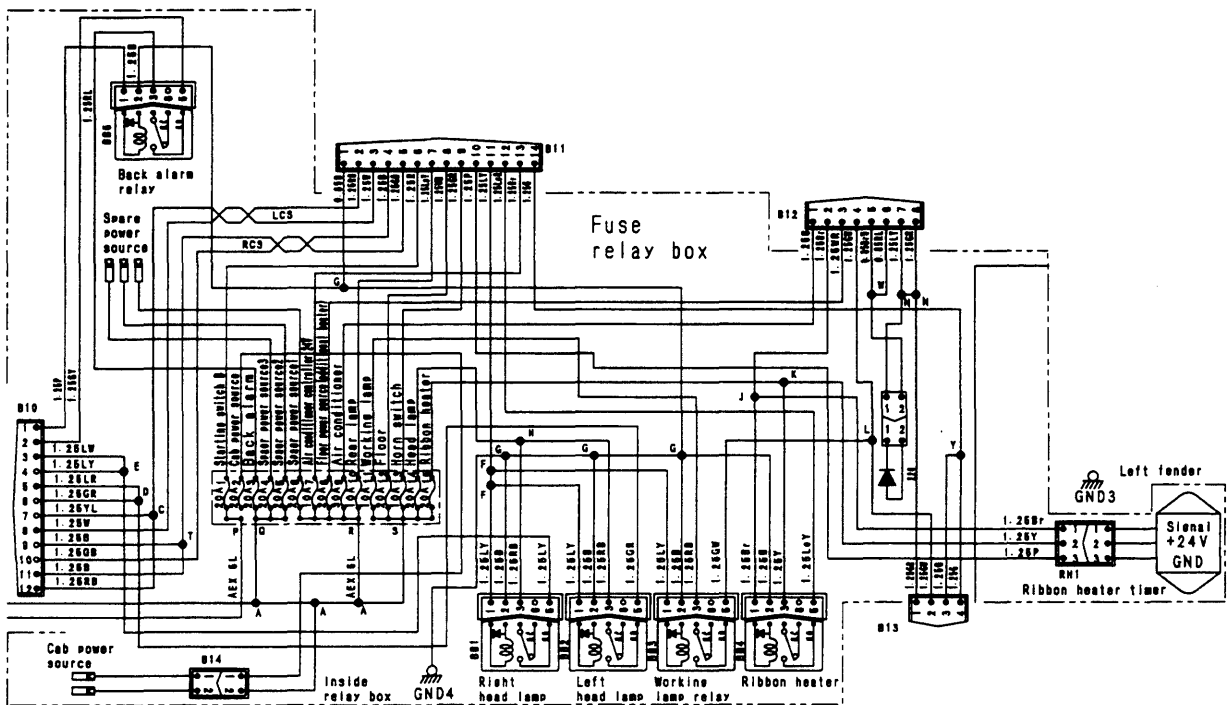

SV003119

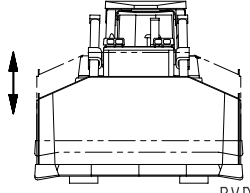
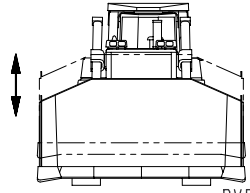
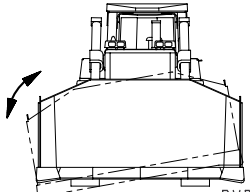
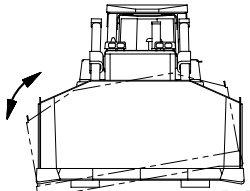
		Model			D475A-3		
Category	Item	Measurement conditions		Unit	Standard value	Permissible value	
Work equipment	Blade speed	Blade lift (Single tiltdozer specification) (Dual tiltdozer specification)	 <p>BVD00808</p> <ul style="list-style-type: none"> Hydraulic oil temperature: 45 – 55°C Blade: No load Blade in contact with ground – Raised to max. height 	RAISE	Low idling	13.0 – 18.0	Max. 20.0
					High idling	3.6 – 4.6	Max. 5.0
				LOWER	Low idling	1.0 – 1.5	Max. 2.0
					High idling	1.0 – 1.5	Max. 2.0
		Blade lift (Superdozer specification)	 <p>BVD00808</p> <ul style="list-style-type: none"> Hydraulic oil temperature: 45 – 55°C Blade: No load Blade in contact with ground – Raised to max. height 	RAISE	Low idling	18.0 – 25.0	Max. 28
					High idling	5.5 – 6.5	Max. 8.0
				LOWER	Low idling	1.2 – 1.8	Max. 2.8
					High idling	1.2 – 1.8	Max. 2.0
	Blade tilt	Blade tilt (Single tiltdozer specification)	 <p>BVD00809</p> <ul style="list-style-type: none"> Hydraulic oil temperature: 45 – 55°C Blade: No load Full left tilt – Full right tilt 	Left tilt	Low idling	14.1 – 17.3	Max. 19.0
					High idling	4.3 – 5.3	Max. 7.0
				Right tilt	Low idling	9.7 – 11.9	Max. 14.0
					High idling	3.0 – 3.6	Max. 5.0
		Blade tilt (Dual tiltdozer specification)	 <p>BVD00809</p> <ul style="list-style-type: none"> Hydraulic oil temperature: 45 – 55°C Blade: No load Full left tilt – Full right tilt 	Left tilt	Low idling		
					High idling		
				Right tilt	Low idling		
					High idling		

System	Name of component	Connector No.	Inspection method	Judgement table	Measurement conditions								
Machine controller system	Blade RAISE oil pressure switch	BLU (male)	Measure resistance	<p>If the condition is as shown in the table below, it is normal.</p> <table border="1"> <tr> <td rowspan="2">Between (1) - (2)</td> <td>Blade lever at HOLD</td> <td>Min. 1 MΩ</td> </tr> <tr> <td>Blade lever at RAISE</td> <td>Max. 1 Ω</td> </tr> <tr> <td>Between (1)(2) - chassis</td> <td>—</td> <td>Min. 1 MΩ</td> </tr> </table>	Between (1) - (2)	Blade lever at HOLD	Min. 1 MΩ	Blade lever at RAISE	Max. 1 Ω	Between (1)(2) - chassis	—	Min. 1 MΩ	1) Disconnect connector. 2) Start engine.
	Between (1) - (2)	Blade lever at HOLD	Min. 1 MΩ										
		Blade lever at RAISE	Max. 1 Ω										
	Between (1)(2) - chassis	—	Min. 1 MΩ										
	Blade LOWER oil pressure switch	BLD (male)	Measure resistance	<p>If the condition is as shown in the table below, it is normal.</p> <table border="1"> <tr> <td rowspan="2">Between (1) - (2)</td> <td>Blade lever at HOLD</td> <td>Min. 1 MΩ</td> </tr> <tr> <td>Blade lever at LOWER</td> <td>Max. 1 Ω</td> </tr> <tr> <td>Between (1)(2) - chassis</td> <td>—</td> <td>Min. 1 MΩ</td> </tr> </table>	Between (1) - (2)	Blade lever at HOLD	Min. 1 MΩ	Blade lever at LOWER	Max. 1 Ω	Between (1)(2) - chassis	—	Min. 1 MΩ	1) Disconnect connector. 2) Start engine.
	Between (1) - (2)	Blade lever at HOLD	Min. 1 MΩ										
		Blade lever at LOWER	Max. 1 Ω										
	Between (1)(2) - chassis	—	Min. 1 MΩ										
Blade left tilt oil pressure switch	TLS (male)	Measure resistance	<p>If the condition is as shown in the table below, it is normal.</p> <table border="1"> <tr> <td rowspan="2">Between (1) - (2)</td> <td>Blade lever at HOLD</td> <td>Min. 1 MΩ</td> </tr> <tr> <td>Blade lever at left tilt</td> <td>Max. 1 Ω</td> </tr> <tr> <td>Between (1)(2) - chassis</td> <td>—</td> <td>Min. 1 MΩ</td> </tr> </table>	Between (1) - (2)	Blade lever at HOLD	Min. 1 MΩ	Blade lever at left tilt	Max. 1 Ω	Between (1)(2) - chassis	—	Min. 1 MΩ	1) Disconnect connector. 2) Start engine.	
Between (1) - (2)	Blade lever at HOLD	Min. 1 MΩ											
	Blade lever at left tilt	Max. 1 Ω											
Between (1)(2) - chassis	—	Min. 1 MΩ											
Blade right tilt oil pressure switch	TRS (male)	Measure resistance	<p>If the condition is as shown in the table below, it is normal.</p> <table border="1"> <tr> <td rowspan="2">Between (1) - (2)</td> <td>Blade lever at HOLD</td> <td>Min. 1 MΩ</td> </tr> <tr> <td>Blade lever at right tilt</td> <td>Max. 1 Ω</td> </tr> <tr> <td>Between (1)(2) - chassis</td> <td>—</td> <td>Min. 1 MΩ</td> </tr> </table>	Between (1) - (2)	Blade lever at HOLD	Min. 1 MΩ	Blade lever at right tilt	Max. 1 Ω	Between (1)(2) - chassis	—	Min. 1 MΩ	1) Disconnect connector. 2) Start engine.	
Between (1) - (2)	Blade lever at HOLD	Min. 1 MΩ											
	Blade lever at right tilt	Max. 1 Ω											
Between (1)(2) - chassis	—	Min. 1 MΩ											
Ripper RAISE oil pressure switch	RPU (male)	Measure resistance	<p>If the condition is as shown in the table below, it is normal.</p> <table border="1"> <tr> <td rowspan="2">Between (1) - (2)</td> <td>Ripper lever at HOLD</td> <td>Min. 1 MΩ</td> </tr> <tr> <td>Ripper lever at RAISE</td> <td>Max. 1 Ω</td> </tr> <tr> <td>Between (1)(2) - chassis</td> <td>—</td> <td>Min. 1 MΩ</td> </tr> </table>	Between (1) - (2)	Ripper lever at HOLD	Min. 1 MΩ	Ripper lever at RAISE	Max. 1 Ω	Between (1)(2) - chassis	—	Min. 1 MΩ	1) Disconnect connector. 2) Start engine.	
Between (1) - (2)	Ripper lever at HOLD	Min. 1 MΩ											
	Ripper lever at RAISE	Max. 1 Ω											
Between (1)(2) - chassis	—	Min. 1 MΩ											
Ripper LOWER oil pressure switch	RPD (male)	Measure resistance	<p>If the condition is as shown in the table below, it is normal.</p> <table border="1"> <tr> <td rowspan="2">Between (1) - (2)</td> <td>Ripper lever at HOLD</td> <td>Min. 1 MΩ</td> </tr> <tr> <td>Ripper lever at LOWER</td> <td>Max. 1 Ω</td> </tr> <tr> <td>Between (1)(2) - chassis</td> <td>—</td> <td>Min. 1 MΩ</td> </tr> </table>	Between (1) - (2)	Ripper lever at HOLD	Min. 1 MΩ	Ripper lever at LOWER	Max. 1 Ω	Between (1)(2) - chassis	—	Min. 1 MΩ	1) Disconnect connector. 2) Start engine.	
Between (1) - (2)	Ripper lever at HOLD	Min. 1 MΩ											
	Ripper lever at LOWER	Max. 1 Ω											
Between (1)(2) - chassis	—	Min. 1 MΩ											
Ripper TILT IN oil pressure switch	RTI (male)	Measure resistance	<p>If the condition is as shown in the table below, it is normal.</p> <table border="1"> <tr> <td rowspan="2">Between (1) - (2)</td> <td>Ripper lever at HOLD</td> <td>Min. 1 MΩ</td> </tr> <tr> <td>Ripper lever at TILT IN</td> <td>Max. 1 Ω</td> </tr> <tr> <td>Between (1)(2) - chassis</td> <td>—</td> <td>Min. 1 MΩ</td> </tr> </table>	Between (1) - (2)	Ripper lever at HOLD	Min. 1 MΩ	Ripper lever at TILT IN	Max. 1 Ω	Between (1)(2) - chassis	—	Min. 1 MΩ	1) Disconnect connector. 2) Start engine.	
Between (1) - (2)	Ripper lever at HOLD	Min. 1 MΩ											
	Ripper lever at TILT IN	Max. 1 Ω											
Between (1)(2) - chassis	—	Min. 1 MΩ											
Ripper TILT BACK oil pressure switch	RTB (male)	Measure resistance	<p>If the condition is as shown in the table below, it is normal.</p> <table border="1"> <tr> <td rowspan="2">Between (1) - (2)</td> <td>Ripper lever at HOLD</td> <td>Min. 1 MΩ</td> </tr> <tr> <td>Ripper lever at TILT BACK</td> <td>Max. 1 Ω</td> </tr> <tr> <td>Between (1)(2) - chassis</td> <td>—</td> <td>Min. 1 MΩ</td> </tr> </table>	Between (1) - (2)	Ripper lever at HOLD	Min. 1 MΩ	Ripper lever at TILT BACK	Max. 1 Ω	Between (1)(2) - chassis	—	Min. 1 MΩ	1) Disconnect connector. 2) Start engine.	
Between (1) - (2)	Ripper lever at HOLD	Min. 1 MΩ											
	Ripper lever at TILT BACK	Max. 1 Ω											
Between (1)(2) - chassis	—	Min. 1 MΩ											

System	Name of component	Connector No.	Inspection method	Judgement table	Measurement conditions											
Monitor panel system	Monitor panel (caution module)	CN1	Measure voltage	<p>If the condition is as shown in the table below, it is normal.</p> <table border="1"> <tr> <td rowspan="2">Between (7) - (2)</td> <td>Engine oil pressure 0.05 MPa (0.5 kg/cm²) or above</td> <td>20 - 30 V</td> </tr> <tr> <td>Engine oil pressure below 0.05 MPa (0.5 kg/cm²)</td> <td>Max. 1 V</td> </tr> </table>	Between (7) - (2)	Engine oil pressure 0.05 MPa (0.5 kg/cm ²) or above	20 - 30 V	Engine oil pressure below 0.05 MPa (0.5 kg/cm ²)	Max. 1 V	<ol style="list-style-type: none"> 1) Insert T-adapter. 2) Turn starting switch ON. 						
				Between (7) - (2)		Engine oil pressure 0.05 MPa (0.5 kg/cm ²) or above	20 - 30 V									
			Engine oil pressure below 0.05 MPa (0.5 kg/cm ²)		Max. 1 V											
			Measure voltage	<p>If the condition is as shown in the table below, it is normal.</p> <table border="1"> <tr> <td rowspan="2">Between (8) - (2)</td> <td>Oil temperature below 105°C</td> <td>Max. 1 V</td> </tr> <tr> <td>Oil temperature 105°C or above</td> <td>20 - 30 V</td> </tr> </table>	Between (8) - (2)	Oil temperature below 105°C	Max. 1 V	Oil temperature 105°C or above	20 - 30 V	<ol style="list-style-type: none"> 1) Insert T-adapter. 2) Turn starting switch ON. 						
		Between (8) - (2)		Oil temperature below 105°C		Max. 1 V										
			Oil temperature 105°C or above	20 - 30 V												
		Measure voltage	<p>If the condition is as shown in the table below, it is normal.</p> <table border="1"> <tr> <td rowspan="2">Between (9) - (2)</td> <td>When air cleaner is normal</td> <td>Max. 1 V</td> </tr> <tr> <td>When air cleaner is clogged</td> <td>20 - 30 V</td> </tr> </table>	Between (9) - (2)	When air cleaner is normal	Max. 1 V	When air cleaner is clogged	20 - 30 V	<ol style="list-style-type: none"> 1) Insert T-adapter. 2) Turn starting switch ON. 							
			Between (9) - (2)		When air cleaner is normal	Max. 1 V										
		When air cleaner is clogged		20 - 30 V												
		Measure voltage	<p>If the condition is as shown in the table below, it is normal.</p> <table border="1"> <tr> <td colspan="2">Between (11) (12) - (10)</td> <td>4.0 - 10.0 V</td> </tr> </table>	Between (11) (12) - (10)		4.0 - 10.0 V	<ol style="list-style-type: none"> 1) Insert T-adapter. 2) Turn starting switch ON. 									
Between (11) (12) - (10)			4.0 - 10.0 V													
CN1 (female) CN2 (female)	Measure resistance	<p>If the condition is as shown in the table below, it is normal.</p> <table border="1"> <tr> <td rowspan="6">Between CN2 (1) - CN1 (2)</td> <td>Water temperature 70°C (level 1)</td> <td>Approx. 8.8 kΩ</td> </tr> <tr> <td>Water temperature 83°C (level 2)</td> <td>Approx. 6 kΩ</td> </tr> <tr> <td>Water temperature 94°C (level 3)</td> <td>Approx. 4.4 kΩ</td> </tr> <tr> <td>Water temperature 98°C (level 4)</td> <td>Approx. 4.0 kΩ</td> </tr> <tr> <td>Water temperature 102°C (level 5)</td> <td>Approx. 3.5 kΩ</td> </tr> <tr> <td>Water temperature 108°C (level 6)</td> <td>Approx. 3.1 kΩ</td> </tr> </table>	Between CN2 (1) - CN1 (2)	Water temperature 70°C (level 1)	Approx. 8.8 kΩ	Water temperature 83°C (level 2)	Approx. 6 kΩ	Water temperature 94°C (level 3)	Approx. 4.4 kΩ	Water temperature 98°C (level 4)	Approx. 4.0 kΩ	Water temperature 102°C (level 5)	Approx. 3.5 kΩ	Water temperature 108°C (level 6)	Approx. 3.1 kΩ	<ol style="list-style-type: none"> 1) Turn starting switch OFF. 2) Disconnect connector.
		Between CN2 (1) - CN1 (2)		Water temperature 70°C (level 1)	Approx. 8.8 kΩ											
				Water temperature 83°C (level 2)	Approx. 6 kΩ											
				Water temperature 94°C (level 3)	Approx. 4.4 kΩ											
				Water temperature 98°C (level 4)	Approx. 4.0 kΩ											
				Water temperature 102°C (level 5)	Approx. 3.5 kΩ											
Water temperature 108°C (level 6)	Approx. 3.1 kΩ															
Measure resistance	<p>If the condition is as shown in the table below, it is normal.</p> <table border="1"> <tr> <td rowspan="6">Between CN2 (2) - CN1 (2)</td> <td>Water temperature 50°C (level 1)</td> <td>Approx. 17 kΩ</td> </tr> <tr> <td>Water temperature 90°C (level 2)</td> <td>Approx. 5 kΩ</td> </tr> <tr> <td>Water temperature 110°C (level 3)</td> <td>Approx. 2.9 kΩ</td> </tr> <tr> <td>Water temperature 116°C (level 4)</td> <td>Approx. 2.5 kΩ</td> </tr> <tr> <td>Water temperature 120°C (level 5)</td> <td>Approx. 2.3 kΩ</td> </tr> <tr> <td>Water temperature 130°C (level 6)</td> <td>Approx. 1.8 kΩ</td> </tr> </table>	Between CN2 (2) - CN1 (2)	Water temperature 50°C (level 1)	Approx. 17 kΩ	Water temperature 90°C (level 2)	Approx. 5 kΩ	Water temperature 110°C (level 3)	Approx. 2.9 kΩ	Water temperature 116°C (level 4)	Approx. 2.5 kΩ	Water temperature 120°C (level 5)	Approx. 2.3 kΩ	Water temperature 130°C (level 6)	Approx. 1.8 kΩ	<ol style="list-style-type: none"> 1) Turn starting switch OFF. 2) Disconnect connector. 	
	Between CN2 (2) - CN1 (2)		Water temperature 50°C (level 1)	Approx. 17 kΩ												
			Water temperature 90°C (level 2)	Approx. 5 kΩ												
			Water temperature 110°C (level 3)	Approx. 2.9 kΩ												
			Water temperature 116°C (level 4)	Approx. 2.5 kΩ												
			Water temperature 120°C (level 5)	Approx. 2.3 kΩ												
Water temperature 130°C (level 6)		Approx. 1.8 kΩ														
Measure resistance	<p>If the condition is as shown in the table below, it is normal.</p> <table border="1"> <tr> <td rowspan="4">Between CN2 (3) - CN1 (2)</td> <td>Fuel EMPTY</td> <td>Approx. 75 kΩ</td> </tr> <tr> <td>Level 3/7</td> <td>Approx. 50 kΩ</td> </tr> <tr> <td>Level 5/7</td> <td>Approx. 35 kΩ</td> </tr> <tr> <td>FULL</td> <td>Approx. 14 kΩ</td> </tr> </table>	Between CN2 (3) - CN1 (2)	Fuel EMPTY	Approx. 75 kΩ	Level 3/7	Approx. 50 kΩ	Level 5/7	Approx. 35 kΩ	FULL	Approx. 14 kΩ	<ol style="list-style-type: none"> 1) Turn starting switch OFF. 2) Disconnect connector. 					
	Between CN2 (3) - CN1 (2)		Fuel EMPTY	Approx. 75 kΩ												
			Level 3/7	Approx. 50 kΩ												
			Level 5/7	Approx. 35 kΩ												
FULL		Approx. 14 kΩ														
Measure resistance	<p>If the condition is as shown in the table below, it is normal.</p> <table border="1"> <tr> <td rowspan="3">Between CN2 (3) - CN1 (2)</td> <td>Fuel EMPTY</td> <td>Approx. 75 kΩ</td> </tr> <tr> <td>Level 3/7</td> <td>Approx. 50 kΩ</td> </tr> <tr> <td>Level 5/7</td> <td>Approx. 35 kΩ</td> </tr> </table>	Between CN2 (3) - CN1 (2)	Fuel EMPTY	Approx. 75 kΩ	Level 3/7	Approx. 50 kΩ	Level 5/7	Approx. 35 kΩ	<ol style="list-style-type: none"> 1) Turn starting switch OFF. 2) Disconnect connector. 							
			Between CN2 (3) - CN1 (2)	Fuel EMPTY	Approx. 75 kΩ											
				Level 3/7	Approx. 50 kΩ											
Level 5/7	Approx. 35 kΩ															
Measure resistance	<p>If the condition is as shown in the table below, it is normal.</p> <table border="1"> <tr> <td rowspan="2">Between CN2 (3) - CN1 (2)</td> <td>Fuel EMPTY</td> <td>Approx. 75 kΩ</td> </tr> <tr> <td>Level 3/7</td> <td>Approx. 50 kΩ</td> </tr> </table>	Between CN2 (3) - CN1 (2)	Fuel EMPTY	Approx. 75 kΩ	Level 3/7	Approx. 50 kΩ	<ol style="list-style-type: none"> 1) Turn starting switch OFF. 2) Disconnect connector. 									
			Between CN2 (3) - CN1 (2)	Fuel EMPTY	Approx. 75 kΩ											
Level 3/7	Approx. 50 kΩ															
Measure resistance	<p>If the condition is as shown in the table below, it is normal.</p> <table border="1"> <tr> <td rowspan="2">Between CN2 (3) - CN1 (2)</td> <td>Level 5/7</td> <td>Approx. 35 kΩ</td> </tr> <tr> <td>FULL</td> <td>Approx. 14 kΩ</td> </tr> </table>	Between CN2 (3) - CN1 (2)	Level 5/7	Approx. 35 kΩ	FULL	Approx. 14 kΩ	<ol style="list-style-type: none"> 1) Turn starting switch OFF. 2) Disconnect connector. 									
			Between CN2 (3) - CN1 (2)	Level 5/7	Approx. 35 kΩ											
FULL	Approx. 14 kΩ															
Measure resistance	<p>If the condition is as shown in the table below, it is normal.</p> <table border="1"> <tr> <td rowspan="2">Between CN2 (3) - CN1 (2)</td> <td>FULL</td> <td>Approx. 14 kΩ</td> </tr> </table>	Between CN2 (3) - CN1 (2)	FULL	Approx. 14 kΩ	<ol style="list-style-type: none"> 1) Turn starting switch OFF. 2) Disconnect connector. 											
			Between CN2 (3) - CN1 (2)	FULL		Approx. 14 kΩ										
Measure resistance	<p>If the condition is as shown in the table below, it is normal.</p> <table border="1"> <tr> <td rowspan="2">Between CN2 (3) - CN1 (2)</td> <td>FULL</td> <td>Approx. 14 kΩ</td> </tr> </table>	Between CN2 (3) - CN1 (2)		FULL	Approx. 14 kΩ	<ol style="list-style-type: none"> 1) Turn starting switch OFF. 2) Disconnect connector. 										
			Between CN2 (3) - CN1 (2)	FULL	Approx. 14 kΩ											

ADJUSTING VALVE CLEARANCE

1. Remove the cylinder head cover.
 - ★ For details, see TESTING AND ADJUSTING, REMOVAL OF CYLINDER HEAD ASSEMBLY.
2. Rotate the crankshaft in the normal direction to align the R1.6TOP line on crankshaft pulley (1) with pointer (2) and set the R1 cylinder to compression top dead center.
 - ★ At the compression top dead center, the rocker arms for both the intake and exhaust move.
 - If the rocker arms do not move, the cylinder is not at compression top dead center, so rotate the crankshaft one more turn and align the lines again.
 - ★ Use the hexagonal shaft of the alternator drive pulley when cranking.

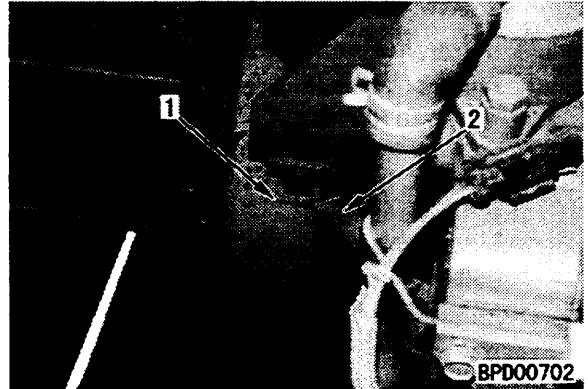

3. Insert feeler gauge D between crosshead (4) and rocker arm (3) of the R1 cylinder, adjust with adjustment screw (5) until the clearance is a sliding fit, then tighten locknut (6) to hold adjustment screw (5) in position.

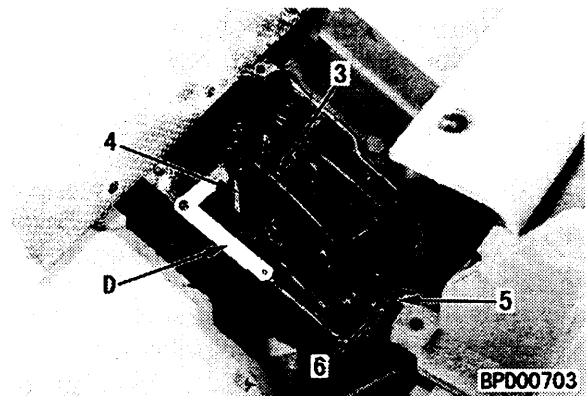

Locknut: $58.8 \pm 5.9 \text{ Nm}$ $\{6 \pm 0.6 \text{ kgm}\}$

- ★ After tightening the locknut, check the valve clearance again.
4. After adjusting the R1 cylinder at compression top dead center, turn the crankshaft 120° each time, align each TOP line on crankshaft pulley (1) with pointer (2), and adjust the clearance of the valves of each cylinder according to the firing order.
 - ★ Firing order :
 R1 - L1 - R5 - L5 - R3 - L3 - R6 - L6 - R2 - L2 - R4 - L4

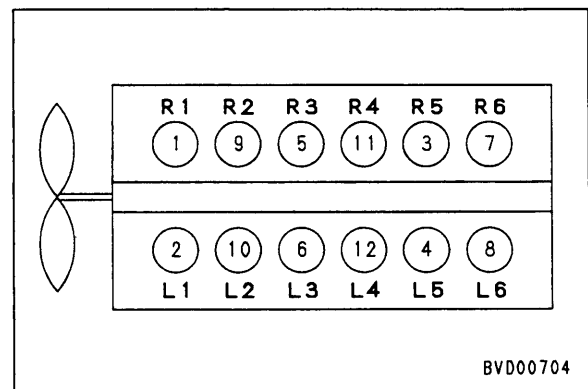
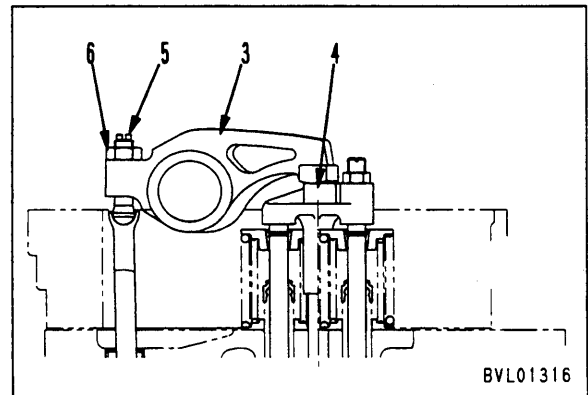

MEASURING TORQUE CONVERTER STALL + HYDRAULIC PUMP RELIEF (FULL STALL) SPEED

★ This applies to the dual tilt dozer specification and superdozer specification.

⚠ Make sure that the area around the machine is safe before starting the operation.

★ Measure the torque converter stall speed under the following conditions.

- Coolant temperature: Within operating range
- Power train oil temperature: Within operating range
- Hydraulic oil temperature: **45 – 55°C**

1. Turn the starting switch ON and set the monitor panel to monitoring code [99].

★ For details, see MEASURING ENGINE SPEED.

2. Start the engine, set the fuel control dial to low idling, then operate the blade lever to move the blade pitch cylinder to the end of the pitch back stroke.

3. Depress the brake pedal firmly, move the full monolever to **3** and the directional lever to **F**.

4. Depress the decelerator pedal and set the fuel control dial to high idling.

5. Let the decelerator pedal back slowly, run the engine at high idling, and stall the torque converter.

⚠ Depress the brake pedal firmly during operation. For safety reasons, always keep your right foot on the decelerator pedal until the completion of the measurement operation.

6. When the power train oil temperature gauge enters the red gauge, immediately return the full monolever to neutral.

7. Repeat Steps 3 – 6 three times.

8. Repeat Steps 3 – 5 again, carry out the blade pitch back relief, and measure the engine speed immediately the power train oil temperature gauge enters the red range.

★ After completion of the measurement, return the full monolever swiftly to neutral, and run the engine at high idling to lower the power train oil temperature.



- ★ For pin ③, use the part (Part No.:04205-10825) or a $\varnothing 8$ pin.
- 2) Adjust dimension **k** between the pins of rod (21), then connect to intermediate lever (20) and steering lever (22).
 - Dimension **k** between pins: **490 mm**
- 3) Adjust dimension **m** between the pins of rod (23), then connect to steering lever (22) and intermediate lever (24).
 - Dimension **m** between pins: **390 mm**
 - ★ Connect so that there is no slack in the input spool of servo valve (17).
- 4) Remove pin (3).

6. Adjustment of parking lever

- 1) Adjust dimension **n** between the pins of rod (25), then connect to parking lever (3) and lock (5).
 - Dimension **n** between pins: **211 mm**
- 2) Set parking lever (3) to the FREE position, then adjust with rod (25) so that height **p** from the tip of parking lever (3) to mounting face of lever stand is dimension given below.
 - Lever height **p**: **285 ± 5 mm**
- 3) Set parking lever (3) to the LOCK position.
- 4) Connect cable (26) to lock (5) and brake valve lever (27).
 - ★ Be careful that brake valve lever (27) is not being pulled.
- 5) Operate parking lever (3) between the FREE position and LOCK position several times and check that it moves smoothly.
- 6) Operate parking lever (3) between the FREE position and LOCK position and check that full monolever (4) is locked or released at the correct position.
- 7) Set parking lever (3) to the LOCK position.
- 8) Adjust so that neutral safety switch (28) is pushed in by amount **q** and is switched ON.
 - Pushing in amount **q**: **2.8 mm**

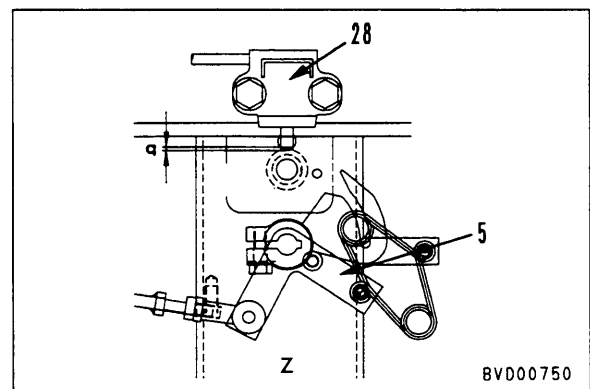
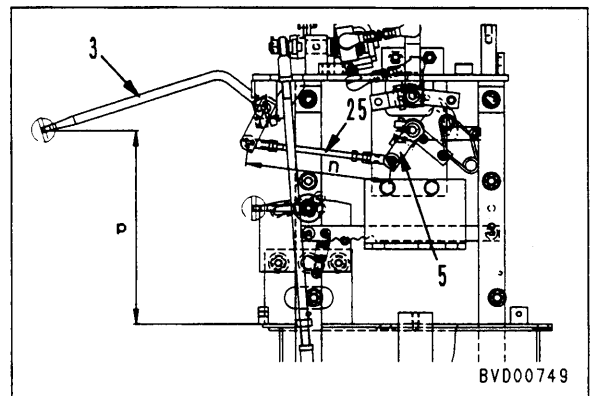

3. Adjusting main relief valve for assist valve

★ If the assist pump relief pressure is not correct, adjust main relief valve (16) of the assist valve as follows.

- 1) Remove cover (17), then loosen locknut (18).
- 2) Turn adjustment screw (19) to adjust.

- ★ Turn the adjustment screw as follows.
- To INCREASE pressure, turn CLOCKWISE
 - To DECREASE pressure, turn COUNTERCLOCKWISE
- ★ Amount of adjustment for one turn of adjustment screw:

2.43 MPa {24.8 kg/cm²}

 **kgm** Locknut:

11.8 – 14.7 Nm {1.2 – 1.5 kgm}

Cover: **29.4 – 39.2 Nm {3.0 – 4.0 kgm}**

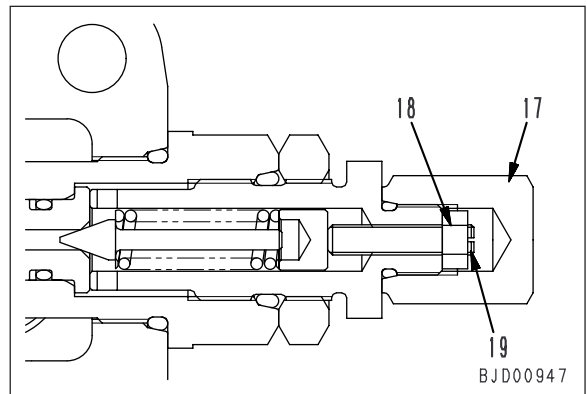
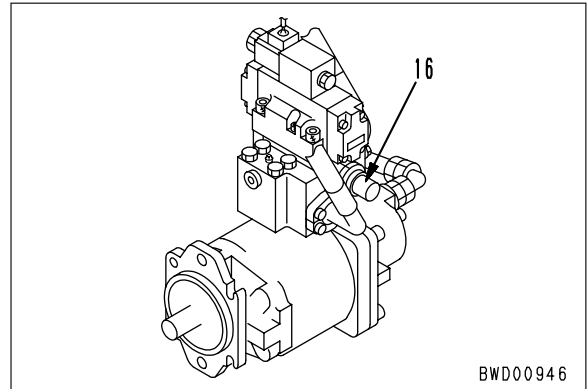

CHECKING LOCATION OF CAUSE OF HYDRAULIC DRIFT OF BLADE AND RIPPER

- ★ If hydraulic drift occurs in the blade and ripper, check as follows to see if the cause is in the cylinder packing or in the control valve.
1. Set the cylinder to be inspected to the following inspection posture, then stop the engine.
 - 1) Blade lift cylinder
 - Push the blade against the ground to raise the front of the chassis.
 - ★ The blade lift cylinder has a built-in piston valve, so do not operate the cylinder to the end of the stroke.
 - 2) Blade tilt cylinder
 - Extend the tilt cylinder rod fully (maximum right tilt), then push the blade against the ground to raise the right side of the chassis.
 - 3) Ripper lift cylinder
 - Push the ripper against the ground to raise the rear of the chassis.
 2. Operate the control lever in the direction to extend the cylinder rod, and check the movement of the cylinder.
 - If the downward movement becomes faster, the packing is defective.
 - If there is no change, the control valve is defective.
 - ★ If there is no more pressure in the accumulator, run the engine for approx. 10 seconds to charge the accumulator before carrying out the operation.

Reference:

If the cause of the hydraulic drift is in the packing, the speed of downward movement in the above operation will become faster for the following reasons.

- 1) With the work equipment in the posture given above, (holding pressure applied to the bottom end), the oil will leak from the bottom end to the head end. However, the volume at the head end is smaller than at the bottom end (by an amount proportional to the volume of the rod), so if the oil flows in from the bottom end, the internal pressure at the head end will rise.
- 2) If the internal pressure at the head end rises, a balance will be made in proportion to this at a certain pressure (this differs according to the amount of leakage). When the pressure becomes balanced, the speed of downward movement becomes slower.

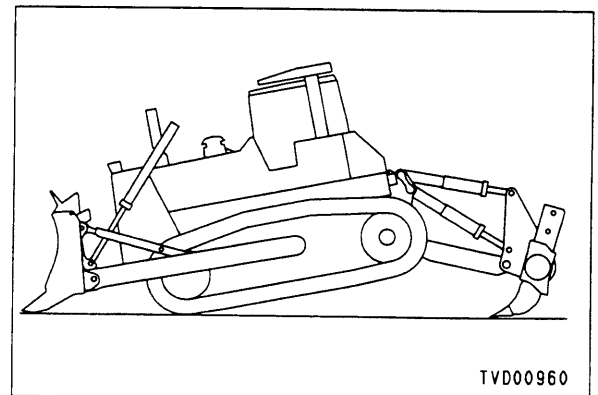
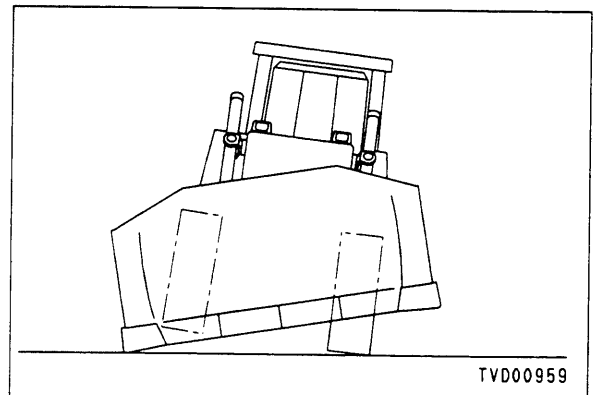
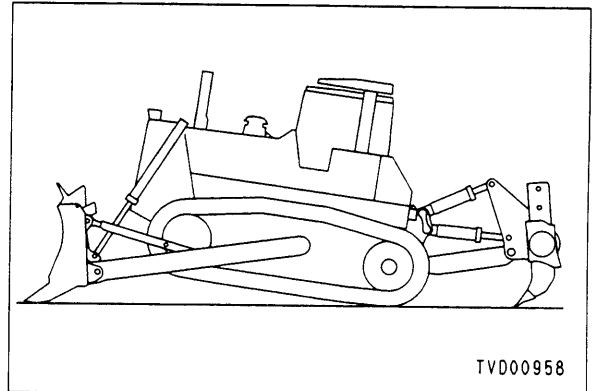

- 3) In this condition, if the lever is operated as shown above, the circuit at the head end is connected to the drain circuit (the bottom end is closed by a check valve), and the oil at the head end flows to the drain circuit. As a result, the balance is lost and the speed of downward movement increases.

TESTING AND ADJUSTING

7. Turn service switch (4) ON again and display [20] on display (6) at the top of the panel.
 8. Operate the blade lever to left tilt and set the left tilt angle to 7°.
 - ★ The tilt limit function will not work, so operate slowly and be careful not to let the tilt angle become too large.
 - ★ Use angle gauge J to adjust the tilt angle correctly.
 9. Press front button (8) on the blade lever to save the left tilt limit value to the system.
 - ★ When the buzzer sounds once, the saving is completed.
 10. Operate the blade lever to right tilt and set the right tilt angle to 7°.
 - ★ The tilt limit function will not work, so operate slowly and be careful not to let the tilt angle become too large.
 - ★ Use angle gauge J to adjust the tilt angle correctly.
 11. Press front button (8) on the blade lever to save the right tilt limit value to the system.
 - ★ When the buzzer sounds once, the saving is completed.
 12. Turn service switch (4) OFF and stop the engine.
 13. Start the engine again, operate the left and right tilt, and check that the blade does not interfere with the track when the blade is raised to any height.
 - Automatic stop angle for tilt: $7 \pm 1^\circ$

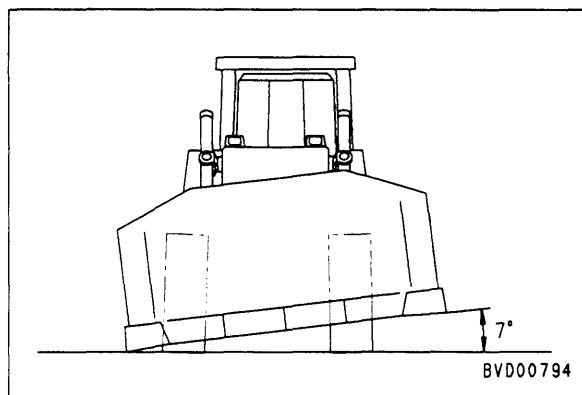
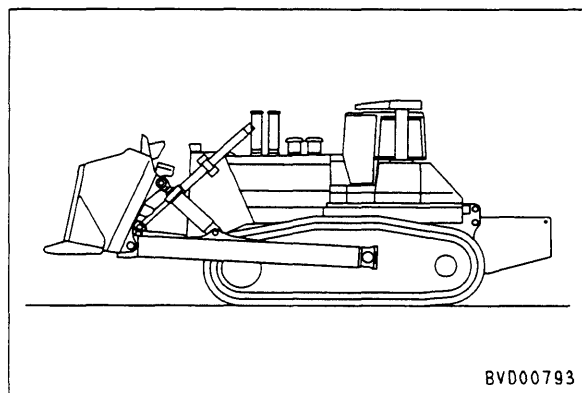
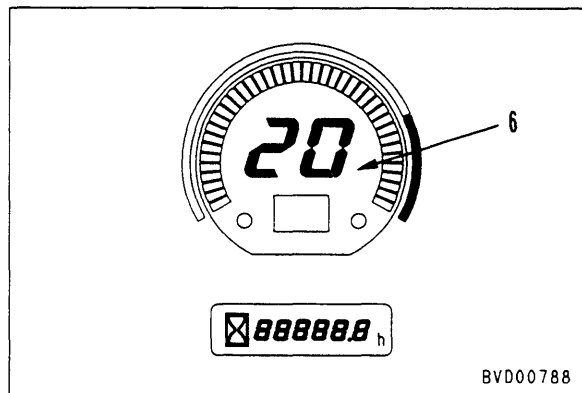

3. POINTS TO REMEMBER WHEN HANDLING HYDRAULIC EQUIPMENT

With the increase in pressure and precision of hydraulic equipment, the most common cause of failure is dirt (foreign material) in the hydraulic circuit. When adding hydraulic oil, or when disassembling or assembling hydraulic equipment, it is necessary to be particularly careful.

1) Be careful of the operating environment.

Avoid adding hydraulic oil, replacing filters, or repairing the machine in rain or high winds, or places where there is a lot of dust.

2) Disassembly and maintenance work in the field

If disassembly or maintenance work is carried out on hydraulic equipment in the field, there is danger of dust entering the equipment. It is also difficult to confirm the performance after repairs, so it is desirable to use unit exchange. Disassembly and maintenance of hydraulic equipment should be carried out in a specially prepared dustproof workshop, and the performance should be confirmed with special test equipment.

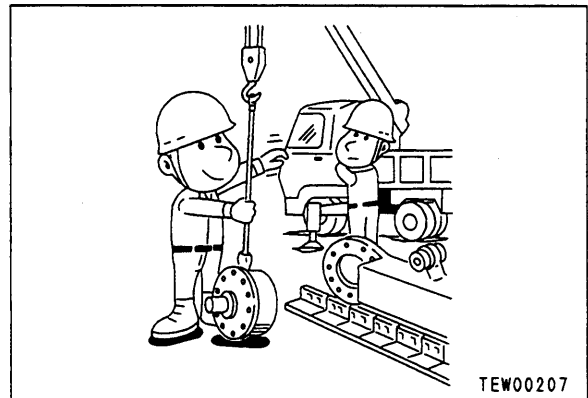

TEW00207

3) Sealing openings

After any piping or equipment is removed, the openings should be sealed with caps, tapes, or vinyl bags to prevent any dirt or dust from entering. If the opening is left open or is blocked with a rag, there is danger of dirt entering or of the surrounding area being made dirty by leaking oil so never do this.

Do not simply drain oil out on to the ground, collect it and ask the customer to dispose of it, or take it back with you for disposal.

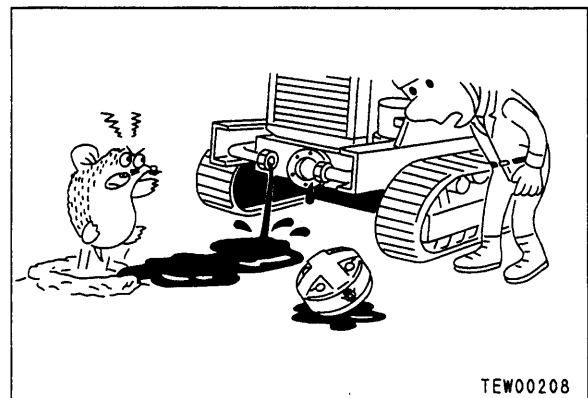

TEW00208

4) Do not let any dirt or dust get in during refilling operations.

Be careful not to let any dirt or dust get in when refilling with hydraulic oil. Always keep the oil filler and the area around it clean, and also use clean pumps and oil containers. If an oil cleaning device is used, it is possible to filter out the dirt that has collected during storage, so this is an even more effective method.

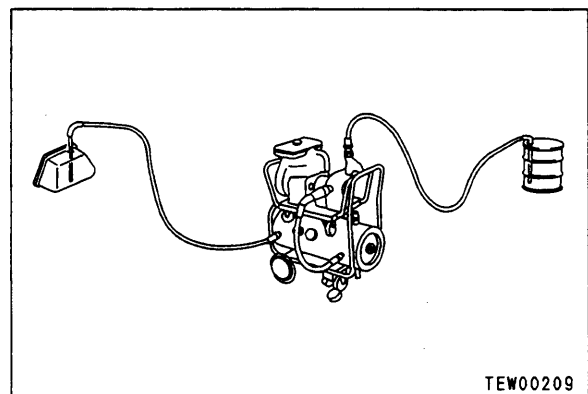

TEW00209

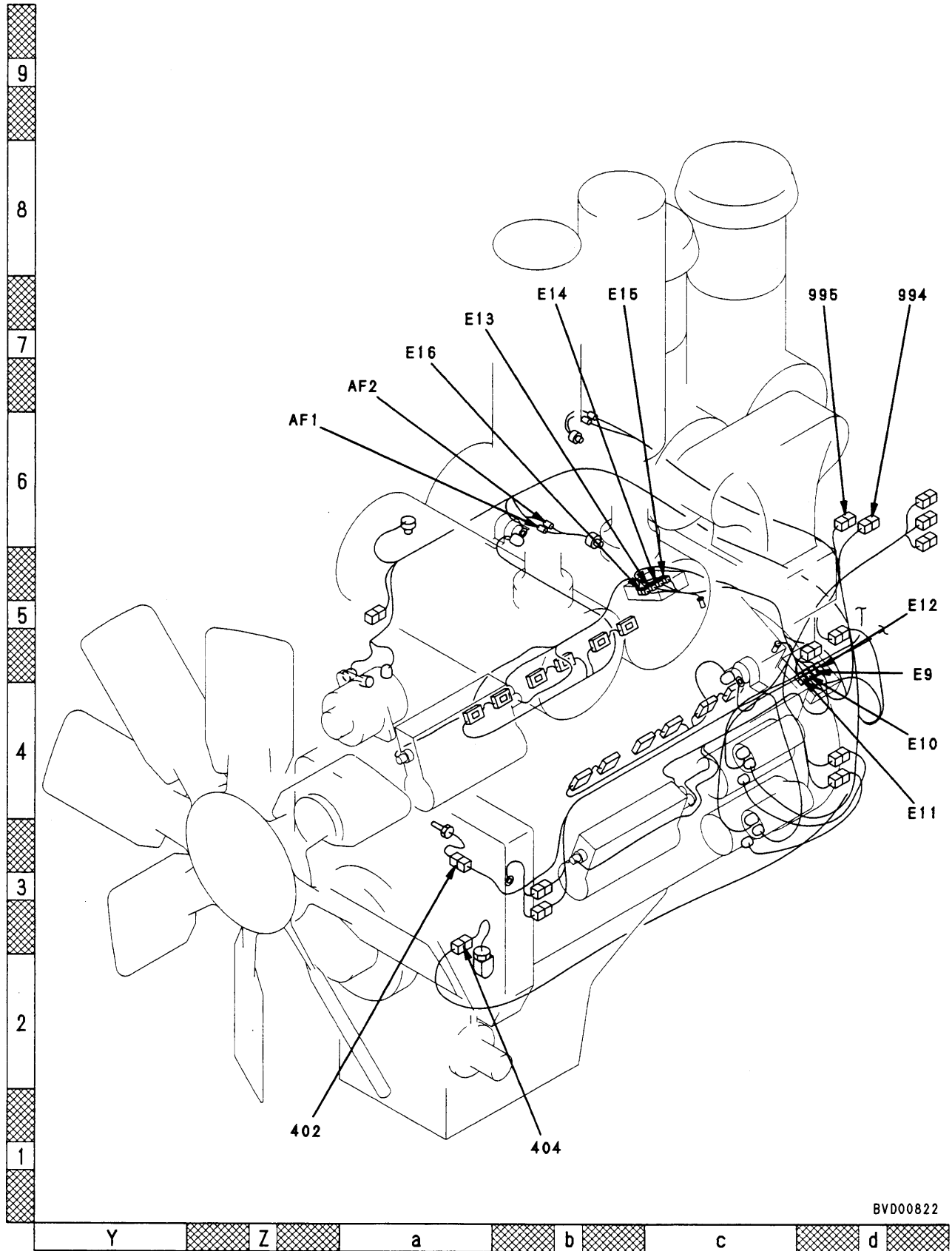

BVD00822

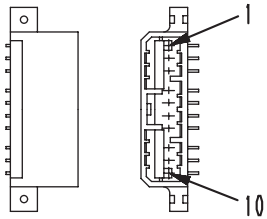
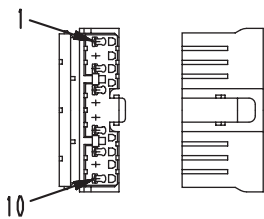
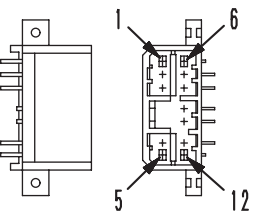
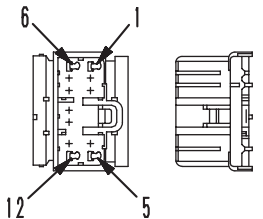
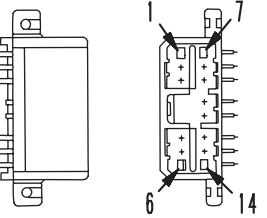
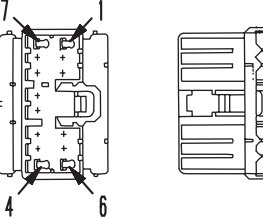
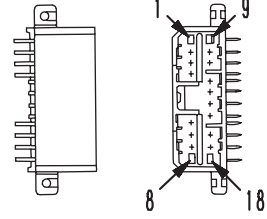
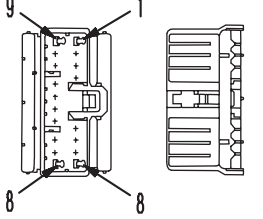
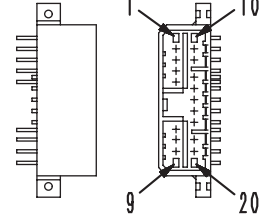
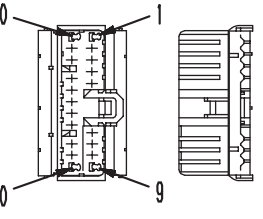
No. of pins	AMP070 type connector		
	Male (female housing)	Female (male housing)	T-adapter Part No.
10	 <p>BWP04759</p>	 <p>BWP04760</p>	799-601-7510
	—	Part number: 08195-10210	
12	 <p>BWP04761</p>	 <p>BWP04762</p>	799-601-7520
	—	Part number: 08195-12210	
14	 <p>BWP04763</p>	 <p>BWP04764</p>	799-601-7530
	—	Part number: 08195-14210	
18	 <p>BWP04765</p>	 <p>BWP04766</p>	799-601-7540
	—	Part number: 08195-18210	
20	 <p>BWP04767</p>	 <p>BWP04768</p>	799-601-7550
	—	Part number: 08195-20210	

[The pin No. is also marked on the connector (electric wire insertion end)]

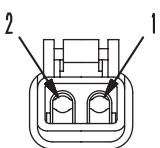
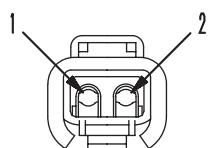
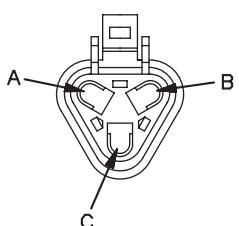
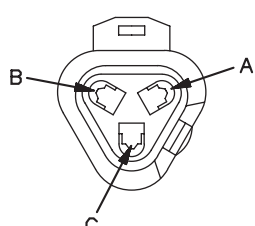
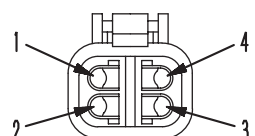
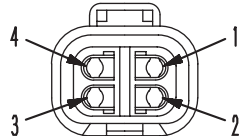
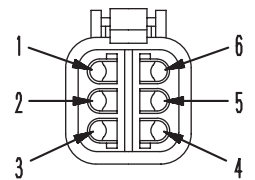
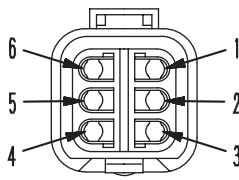
No. of pins	DT Series connector		
	Body (plug)	Body (receptacle)	T-adapter Part No.
2	 <p style="text-align: center;">BWP05037</p>	 <p style="text-align: center;">BWP05038</p>	799-601-9020
	Part number: 08192-12200 (normal type) 08192-22200 (fine wire type)		
3	 <p style="text-align: center;">BWP05039</p>	 <p style="text-align: center;">BWP05040</p>	799-601-9030
	Part number: 08192-13200 (normal type) 08192-23200 (fine wire type)		
4	 <p style="text-align: center;">BWP05041</p>	 <p style="text-align: center;">BWP05042</p>	799-601-9040
	Part number: 08192-14200 (normal type) 08192-24200 (fine wire type)		
6	 <p style="text-align: center;">BWP05043</p>	 <p style="text-align: center;">BWP05044</p>	799-601-9050
	Part number: 08192-16200 (normal type) 08192-26200 (fine wire type)		

Procedure for switching to each mode

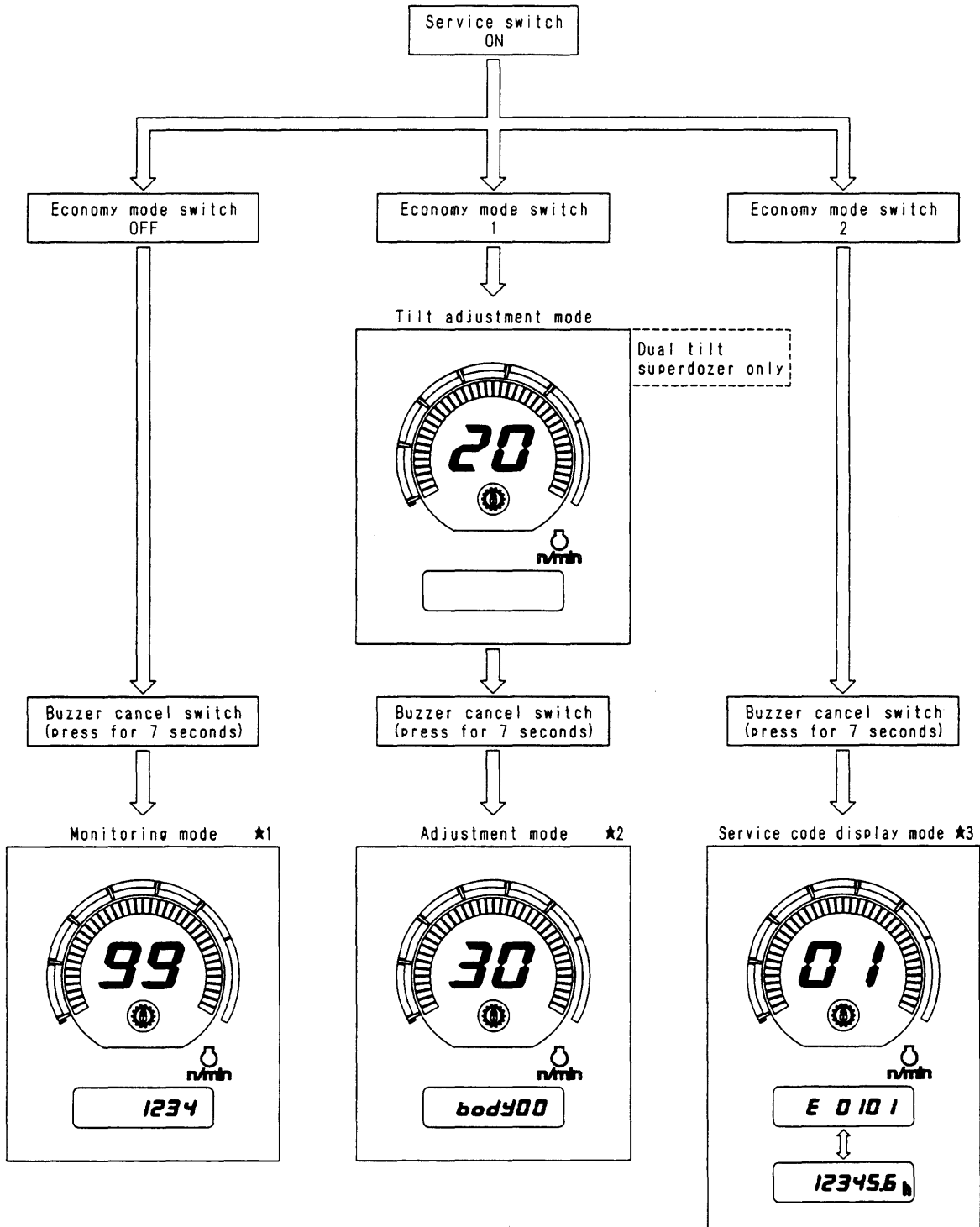

TVD01066

Service code	Abnormal system	Method of re-enaction	Troubleshooting mode	User code
E0334	Short circuit in demand valve solenoid system	E+	C mode	E01
E0335	Disconnection in demand valve solenoid system	S	C mode	E01
E0336	Short circuit in ripper TILT BACK oil pressure switch system	E+	C mode	—
E0337	Short circuit in pitch independent solenoid system	S	C mode	CALL03
E0338	Disconnection in pitch independent solenoid system	E+	C mode	CALL03
E0339	Short circuit in left bottom drain solenoid system	S	C mode	CALL03
E0340	Disconnection in left bottom drain solenoid system	E+	C mode	CALL03
E0351	Abnormality in standard value of blade tilt angle sensor	S	C mode	E01
E0352	Abnormality in compensated value of blade tilt angle sensor	S	C mode	E01
E0360	Short circuit in work equipment oil pressure sensor (140 pump) system	E	C mode	E01
E0361	Disconnection in work equipment oil pressure sensor (140 pump) system	E	C mode	E01
E0362	Short circuit in work equipment oil pressure sensor (140 pump) system	E	C mode	E01
E0363	Disconnection in work equipment oil pressure sensor (140 pump) system	E	C mode	E01
E0401	Abnormality in engine controller power source voltage	S	E mode	CALL
E0402	Abnormality in engine controller	S	E mode	CALL
E0403	Mistaken connection in engine controller	S	E mode	CALL
E0405	Abnormality in fuel control dial system	S	E mode	CALL03
E0406	Abnormality in deceleration potentiometer system	S	E mode	CALL03
E0407	Abnormality in shoe slip control command value	S	E mode	CALL03
E0409	Abnormality in engine speed sensor A system	E	E mode	CALL03
E0410	Abnormality in engine speed sensor B system	E	E mode	CALL03
E0411	Abnormality in right rack sensor system	S	E mode	CALL03
E0412	Abnormality in left rack sensor system	S	E mode	CALL03
E0413	Abnormality in rack sensor power source system	S	E mode	CALL03
E0421	Short circuit in right governor solenoid system	S	E mode	CALL
E0422	Disconnection in right governor solenoid system	S	E mode	CALL
E0423	Short circuit in left governor solenoid system	S	E mode	CALL
E0424	Disconnection in left governor solenoid system	S	E mode	CALL
E0425	Short circuit in right governor cut relay system	S	E mode	E01
E0426	Disconnection in right governor cut relay system	S	E mode	E01
E0427	Short circuit in left governor cut relay system	S	E mode	E01
E0428	Disconnection in left governor cut relay system	S	E mode	E01
E0430	Abnormality in engine oil pressure	E	M mode	CALL
E0431	Abnormality in radiator water level	S	M mode	CALL
E0432	Abnormality in engine water temperature	E	M mode	01
E0433	Short circuit in left pre-stroke solenoid system	S	E mode	CALL03
E0434	Disconnection in left pre-stroke solenoid system	S	E mode	CALL03

N-2 [E0104] Abnormality in network system (monitor panel system) is displayed

- ★ If the starting switch was turned off after the abnormality occurred, turn the starting switch on and check that the service code displays "E" at the head. (If "P" is displayed, the condition has returned to normal.)
- ★ Before carrying out troubleshooting, check that all the related connectors are properly inserted.
- ★ Always connect any disconnected connectors before going on to the next step.

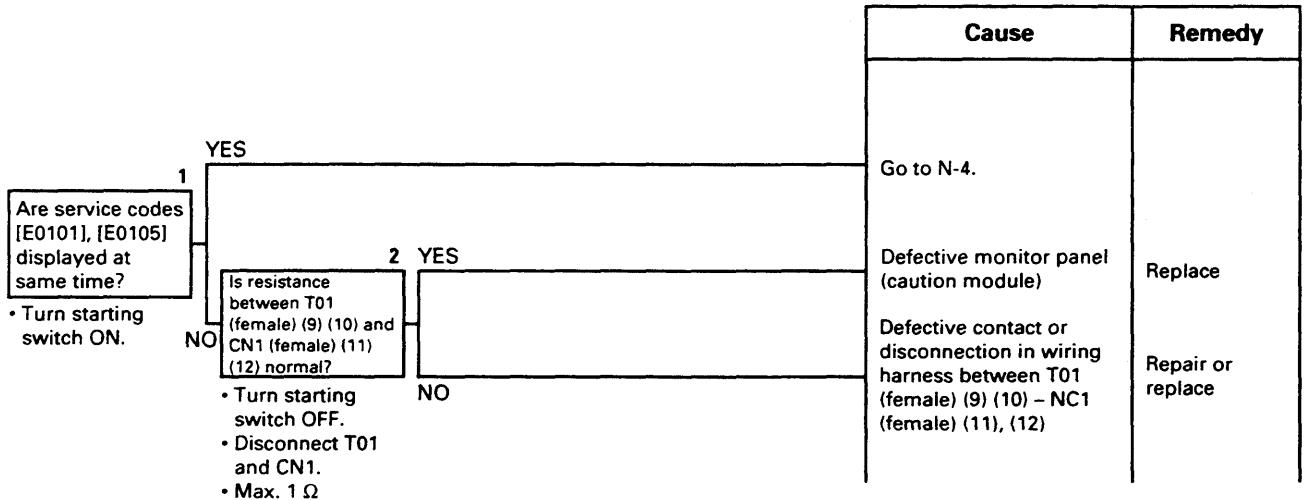

N-2 Related electrical circuit diagram

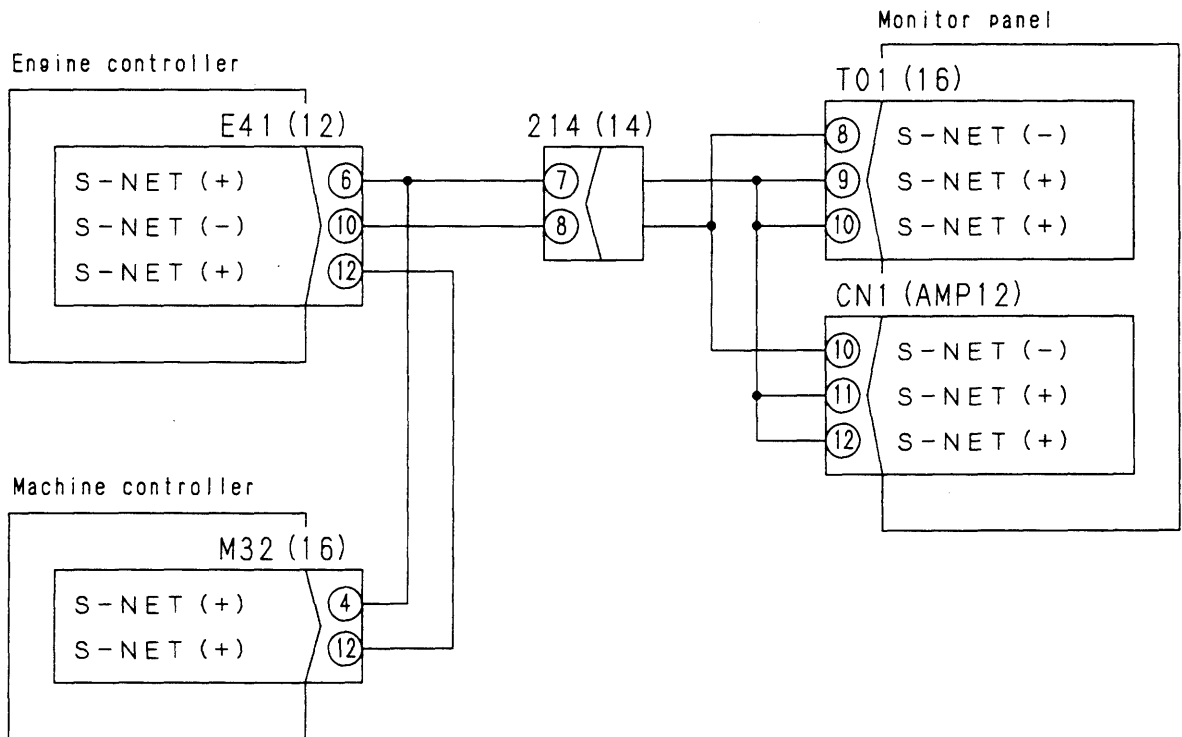

TXD01057

Condition when normal (voltage, current, resistance)	Action by controller when abnormality is detected	Problem that appears on machine when there is abnormality
• Resistance of solenoid: 10 – 21 Ω	1. Lights up caution lamp, sounds alarm buzzer 2. Reduces engine output by 20%	1. Lacks power
• Resistance of sensor: 3.8 – 80 k Ω	1. Lights up caution lamp, sounds alarm buzzer 2. Controls with with engine water temperature taken as 90°C	
	1. Lights up caution lamp, sounds alarm buzzer 2. Sets right fuel injection pump to NO INJECTION condition	1. Engine runs on one bank
	1. Lights up caution lamp, sounds alarm buzzer 2. Sets left fuel injection pump to NO INJECTION condition	1. Engine runs on one bank
• Voltage between E21 (1) and (21): 20 – 30 V	1. Lights up caution lamp, sounds alarm buzzer	1. Engine runs on one bank
• Voltage between E21 (12) and (21): 20 – 30 V	1. Lights up caution lamp, sounds alarm buzzer	1. Engine runs on one bank
• Voltage between E11 (7) and (8)(16): 20 – 30 V	1. Lights up caution lamp, sounds alarm buzzer 2. Drives with switch power source	
• Voltage between E11 (9)(17) and (8)(16): 20 – 30 V	1. Lights up caution lamp, sounds alarm buzzer 2. Drives with backup power source	
	1. Lights up caution lamp, sounds alarm buzzer 2. Runs engine at low idling	1. Engine speed does not go up from low idling
• Resistance of solenoid: 10 – 21 Ω	1. Lights up caution lamp, sounds alarm buzzer 2. Reduces engine output by 20%	1. Lacks power
• Resistance of solenoid: 10 – 21 Ω	1. Lights up caution lamp, sounds alarm buzzer 2. Reduces engine output by 20%	1. Lacks power

E-9 [E0411] Abnormality in right rack sensor system is displayed

- ★ If the starting switch was turned off after the abnormality occurred, turn the starting switch on and check that the service code displays “E” at the head. (If “P” is displayed, the condition has returned to normal.)
- ★ If the operation can be continued, perform the checks in Steps 1 and 2 under the operating condition where a trouble occurs.
- ★ Before carrying out troubleshooting, check that all the related connectors are properly inserted.
- ★ Always connect any disconnected connectors before going on to the next step.

	Cause	Remedy
<p>1</p> <p>Is voltage between E31 (7) and (17) normal?</p> <ul style="list-style-type: none"> • Turn starting switch ON. • 0.15 – 4.5 V 		
<p>2</p> <p>Is voltage between E13 (3) and (4) normal?</p> <ul style="list-style-type: none"> • Turn starting switch ON. • 0.15 – 4.5 V 		
<p>3</p> <p>Is resistance between E13 (female) (3) and (2) and between (4) and (2) normal?</p> <ul style="list-style-type: none"> • Turn starting switch OFF. • Disconnect E31 and E13. • 50 kΩ – 1 MΩ 		
<p>YES</p>	Defective engine controller	Replace with new part
<p>NO</p>	Defective contact or disconnection in wiring harness between E31 (female) (7) – E13 (female) (3) or between E31 (female) (17) – E13 (female) (4)	Repair or replace
<p>NO</p>	Defective right rack sensor or defective internal parts of fuel injection pump	Replace
<p>NO</p>	Short circuit with chassis ground in wiring harness between E31 (female) (7) – E13 (female) (3) or between E31 (female) (17) – E13 (female) (4)	Repair wiring harness or replace

E-9 Related electrical circuit diagram

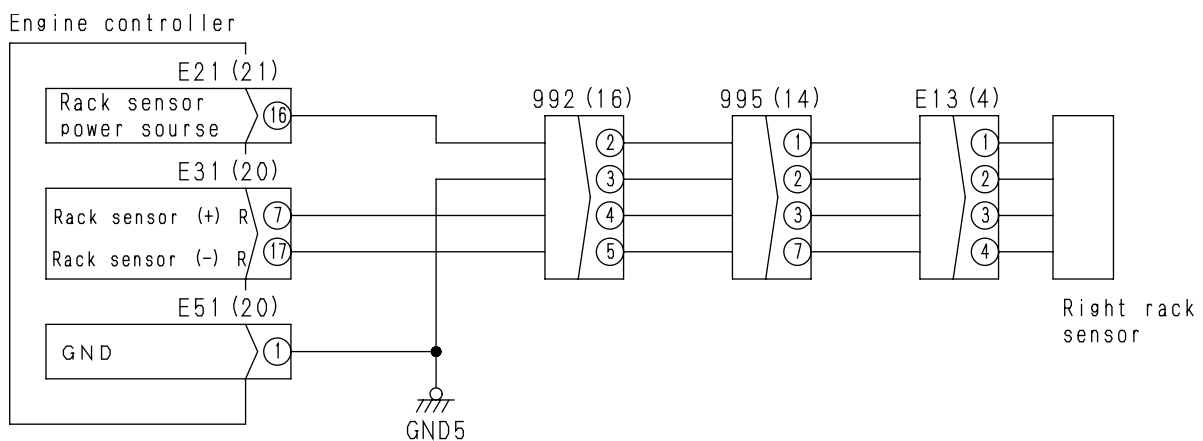

TXD01080

E-17 [E0426] Disconnection in left governor cut relay system is displayed

- ★ If the starting switch was turned off after the abnormality occurred, turn the starting switch on and check that the service code displays "E" at the head. (If "P" is displayed, the condition has returned to normal.)
- ★ Before carrying out troubleshooting, check that all the related connectors are properly inserted.
- ★ Always connect any disconnected connectors before going on to the next step.

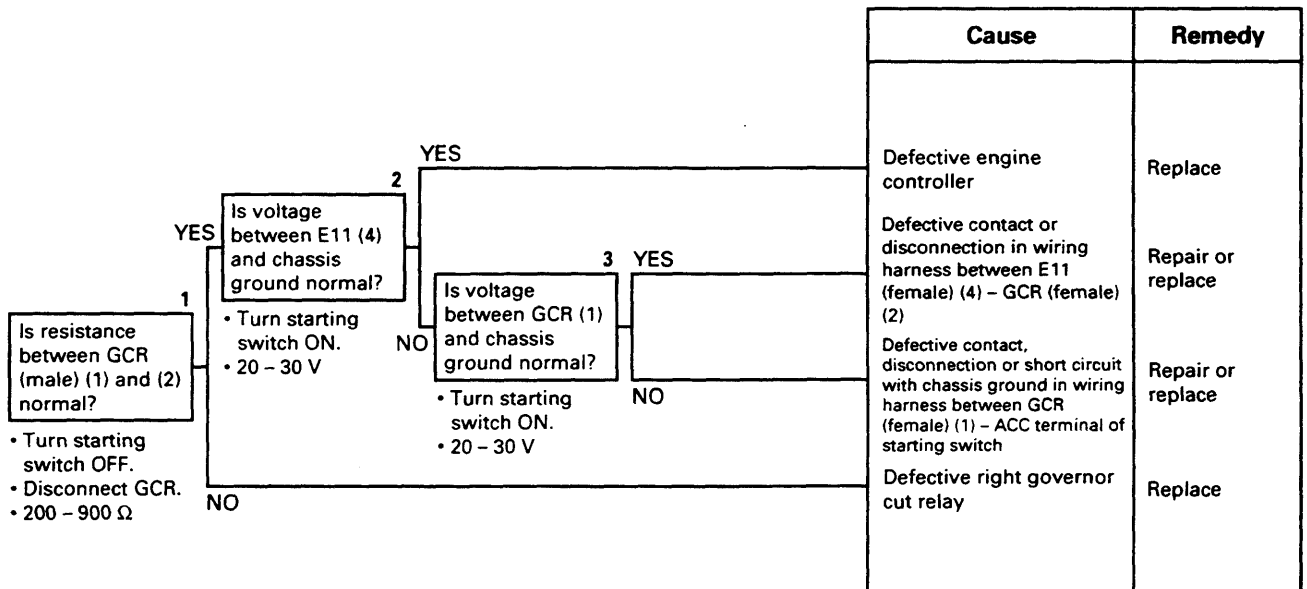

E-17 Related electrical circuit diagram

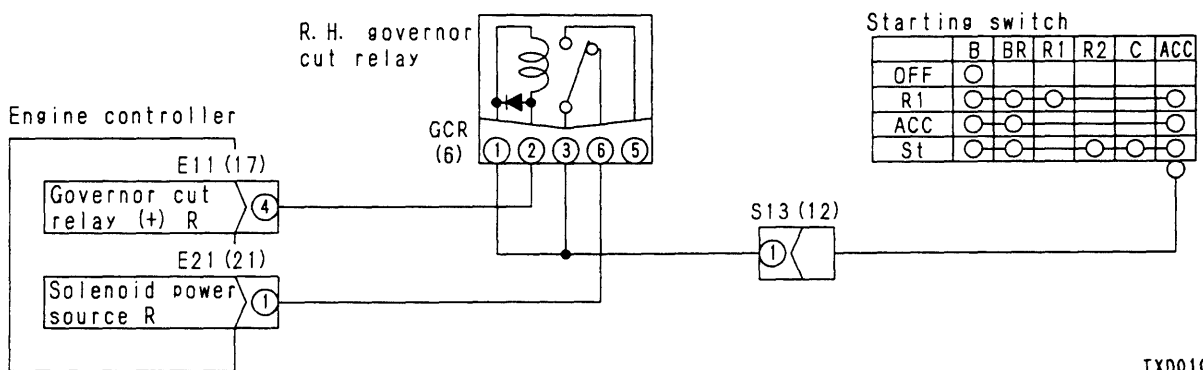

E-28 [E0443] Abnormality in engine controller switch power source system is displayed

- ★ If the starting switch was turned off after the abnormality occurred, turn the starting switch on and check that the service code displays "E" at the head. (If "P" is displayed, the condition has returned to normal.)
- ★ Check that fuse 1 is not broken. (If it is broken, check the circuit related to it for short circuit with chassis ground.)
- ★ Before carrying out troubleshooting, check that all the related connectors are properly inserted.
- ★ Always connect any disconnected connectors before going on to the next step.

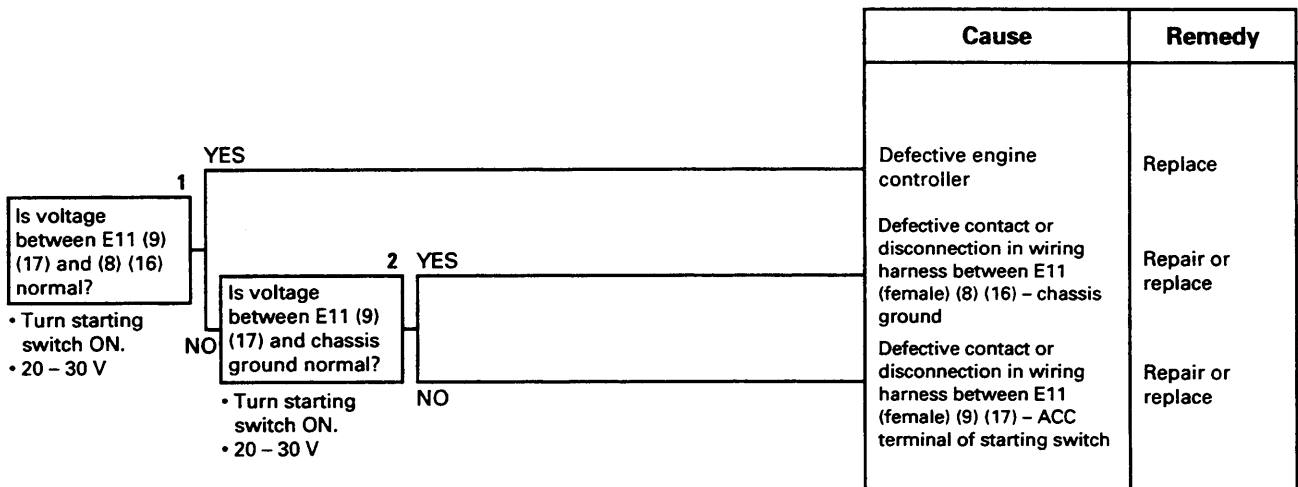

E-28 Related electrical circuit diagram

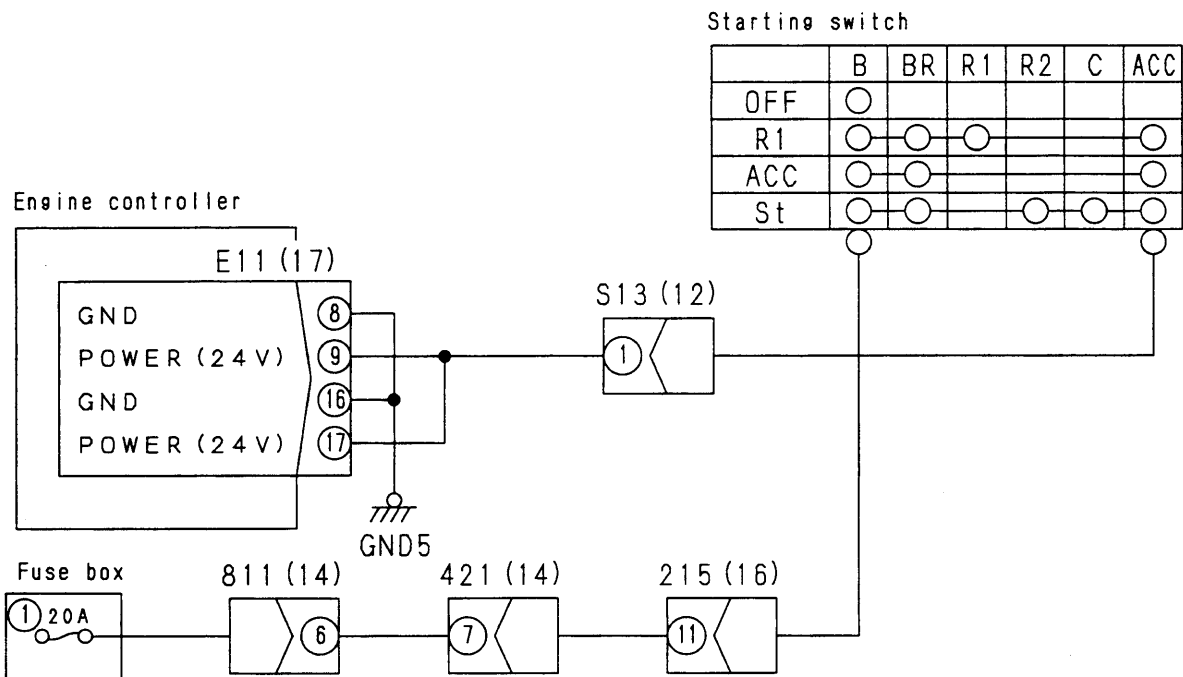

TXD01089

ACTION TAKEN BY CONTROLLER WHEN ABNORMALITY
OCCURS AND PROBLEMS ON MACHINE

User code	Service code	Abnormal system	Nature of abnormality
—	E0111	Abnormality in machine controller power source voltage	※ When the controller power source voltage is less than 17 V 1. Defective contact or disconnection in wiring harness between controller M11 (7)(13), M21 (12) – fuse 12 2. Defective contact or disconnection in wiring harness between controller M11 (6)(12), M21 (11) – chassis ground 3. Drop in battery voltage or defective fuse 12 4. Defective controller
CALL 03	E0150	Abnormality in machine controller E2PROM	※ When an abnormality is detected in the controller non- volatile ROM
	E0151	Abnormality in specification selection	※ When an abnormality is detected in the specification selection data in the program
E01	E0201	Disconnection in torque converter speed sensor system	※ When input voltage from torque converter speed sensor is more than 3.0 V 1. Defective torque converter speed sensor or defective installation 2. Defective contact or disconnection in wiring harness between controller M51 (2) and speed sensor TC1 (1) 3. Defective contact or disconnection in wiring harness between controller M51 (11) and speed sensor TC1 (2) 4. Defective controller
	E0202	Short circuit in torque converter speed sensor system	※ When torque converter speed is more than 500 rpm higher than engine speed 1. Defective torque converter speed sensor 2. Short circuit with ground in wiring harness between controller M51 (2) and speed sensor TC1 (1) 3. Defective controller
	E0203	Disconnection in transmission FORWARD & REVERSE oil pressure switch system	※ When the engine speed is more than 300 rpm and the FORWARD clutch oil pressure switch and REVERSE clutch oil pressure switch are both OFF at the same time 1. Defective FORWARD clutch oil pressure switch or REVERSE clutch oil pressure switch 2. Defective contact or disconnection in wiring harness between controller M31 (8) and oil pressure switch TMF (1) 3. Defective contact or disconnection in wiring harness between oil pressure switch TMF (2) and chassis ground 4. Defective contact or disconnection in wiring harness between controller M31 (18) and oil pressure switch TMR (1) 5. Defective contact or disconnection in wiring harness between oil pressure switch TMR (2) and chassis ground 6. Defective controller
	E0204	Short circuit in transmission FORWARD clutch oil pressure switch system	※ When the engine speed is less than 300 rpm and the FORWARD clutch oil pressure switch is ON 1. Defective FORWARD clutch oil pressure switch 2. Short circuit with ground in wiring harness between controller M31 (8) and oil pressure switch TMF (1) 3. Defective controller
	E0205	Short circuit in transmission REVERSE clutch oil pressure switch system	※ When the engine speed is less than 300 rpm and the REVERSE clutch oil pressure switch is ON 1. Defective REVERSE clutch oil pressure switch 2. Short circuit with ground in wiring harness between controller M31 (18) and oil pressure switch TMR (1) 3. Defective controller
	E0206	Disconnection in transmission 1st & 2nd & 3rd oil pressure switch system	※ When the engine speed is more than 300 rpm and the 1st clutch oil pressure switch, 2nd clutch oil pressure switch, and 3rd clutch oil pressure switch are all OFF at the same time 1. Defective 1st clutch oil pressure switch, 2nd clutch oil pressure switch, or 3rd clutch oil pressure switch 2. Defective contact or disconnection in wiring harness between controller M31 (9) and oil pressure switch TM1 (1) 3. Defective contact or disconnection in wiring harness between oil pressure switch TM1 (2) and chassis ground 4. Defective contact or disconnection in wiring harness between controller M31 (19) and oil pressure switch TM2 (1) 5. Defective contact or disconnection in wiring harness between oil pressure switch TM2 (2) and chassis ground 6. Defective contact or disconnection in wiring harness between controller M31 (10) and oil pressure switch TM3 (1) 7. Defective contact or disconnection in wiring harness between oil pressure switch TM3 (2) and chassis ground 8. Defective controller
	E0207	Short circuit in transmission 1st clutch oil pressure switch system	※ When the engine speed is less than 300 rpm and the 1st clutch oil pressure switch is ON 1. Defective 1st clutch oil pressure switch 2. Short circuit with ground in wiring harness between controller M31 (9) and oil pressure switch TM1 (1) 3. Defective controller

User code	Service code	Abnormal system	Nature of abnormality
E01	E0360	Short circuit in work equipment oil pressure sensor (140 pump) system	※ When input voltage from work equipment oil pressure sensor is more than 4.688 V 1. Defective work equipment oil pressure sensor 2. Defective contact or disconnection in wiring harness between controller M31 (16) and oil pressure sensor HP1 (1) 3. Short circuit with power source in wiring harness between controller M31 (13) and oil pressure sensor HP1 (3)
	E0361	Disconnection in work equipment oil pressure sensor (140 pump) system	※ When input voltage from work equipment oil pressure sensor is less than 0.3 V 1. Defective work equipment oil pressure sensor 2. Short circuit with ground, defective contact, or disconnection in wiring harness between controller M31 (6) and oil pressure sensor HP1 (2) 3. Short circuit with ground, defective contact, or disconnection in wiring harness between controller M31 (13) and oil pressure sensor HP1 (3)
—	E0362	Short circuit in work equipment oil pressure sensor (100 pump) system	※ When input voltage from work equipment oil pressure sensor is more than 4.688 V 1. Defective work equipment oil pressure sensor 2. Defective contact or disconnection in wiring harness between controller M31 (16) and oil pressure sensor HP2 (1) 3. Short circuit with power source in wiring harness between controller M31 (14) and oil pressure sensor HP2 (3)
	E0363	Disconnection in work equipment oil pressure sensor (100 pump) system	※ When input voltage from work equipment oil pressure sensor is less than 0.3 V 1. Defective work equipment oil pressure sensor 2. Short circuit with ground, defective contact, or disconnection in wiring harness between controller M31 (6) and oil pressure sensor HP2 (2) 3. Short circuit with ground, defective contact, or disconnection in wiring harness between controller M31 (14) and oil pressure sensor HP2 (3)
E01	E501	Short circuit in acceleration sensor system	※ When acceleration sensor power source voltage is less than 0.3 V 1. Defective acceleration sensor 2. Short circuit with power source in wiring harness between controller M31 (2) and acceleration sensor SS3 (2) 3. Defective contact or disconnection in wiring harness between controller M31 (17) and acceleration sensor SS3 (3)
	E0502	Disconnection in acceleration sensor system	※ When input voltage from acceleration sensor is more than 4.7 V 1. Defective acceleration sensor 2. Short circuit with ground, defective contact, or disconnection in wiring harness between controller M32 (9) and acceleration sensor SS3 (1) 3. Short circuit with ground, defective contact, or disconnection in wiring harness between controller M31 (2) and acceleration sensor SS3 (2)
—	E0601	Short circuit in buzzer cancel switch system	※ When buzzer cancel switch is continuously ON 1. Defective buzzer cancel switch 2. Short circuit with ground in wiring harness between controller M32 (7) and switch 212 (3) 3. Defective controller
E01	E0610	Short circuit in backup alarm relay system	※ When output voltage to backup alarm relay has become low 1. Defective backup alarm relay 2. Short circuit with ground in wiring harness between controller M11 (9) and relay BB5 (1) 3. Defective controller
	E0611	Disconnection in backup alarm relay system	※ When output voltage to backup alarm relay has become high 1. Defective backup alarm relay 2. Short circuit with power source, defective contact, or disconnection in wiring harness between controller M11 (9) and relay BB5 (1) 3. Defective contact or disconnection in wiring harness between relay BB5 (2) and chassis ground 4. Defective controller
—	E632	Short circuit in bedrock selection mode switch system	※ When input voltage from signal of bedrock selection mode switch is more than 4.688 V 1. Defective monitor panel 2. Short circuit with power source in wiring harness between controller M31 (3) and monitor panel S01 (9) 3. Defective controller
	E0633	Disconnection in bedrock selection mode switch system	※ When input voltage from signal of bedrock selection mode switch is less than 0.293 V 1. Defective monitor panel 2. Short circuit with ground, defective contact, or disconnection in wiring harness between controller M31 (3) and monitor panel S01 (9) 3. Defective controller
	E0930	Disconnection in engine speed sensor system	※ When input voltage from engine speed sensor is more than 3.0 V 1. Defective left engine speed sensor 2. Short circuit with ground, defective contact, or disconnection in wiring harness between controller M41 (1) and speed sensor E12 (1) 2. Defective contact or disconnection in wiring harness between controller M41 (9) and speed sensor E12 (2) 4. Defective controller

C-4 [E0201] Disconnection in torque converter speed sensor system is displayed

- ★ If the starting switch was turned off after the abnormality occurred, start the engine and check that the service code displays "E" at the head. (If "P" is displayed, the condition has returned to normal.)
- ★ Before carrying out troubleshooting, check that all the related connectors are properly inserted.
- ★ Always connect any disconnected connectors before going on to the next step.

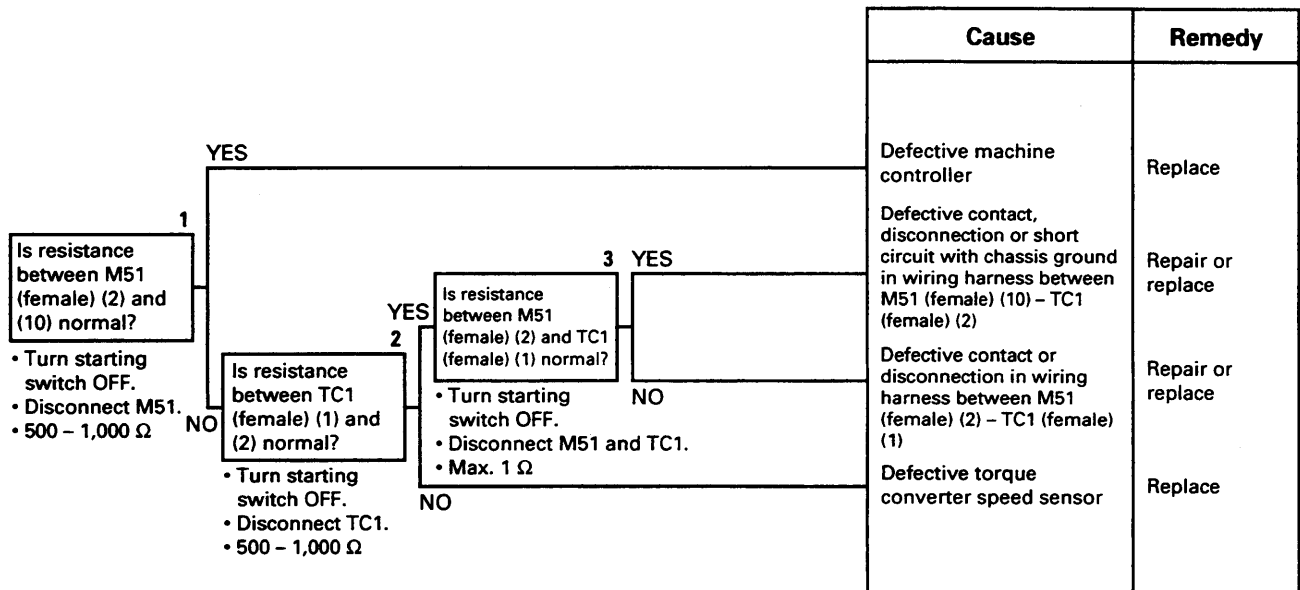

C-4 Related electrical circuit diagram

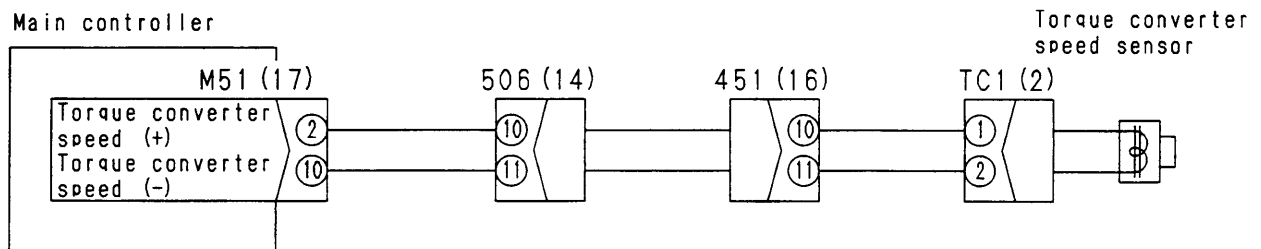

TXD01093

C-13 [E0210] Disconnection in transmission modulating oil pressure sensor system is displayed

- ★ If the starting switch was turned off after the abnormality occurred, run the engine without applying any load for 10 seconds and check that the service code displays "E" at the head. (If "P" is displayed, the condition has returned to normal.)
- ★ Before carrying out troubleshooting, check that all the related connectors are properly inserted.
- ★ Always connect any disconnected connectors before going on to the next step.

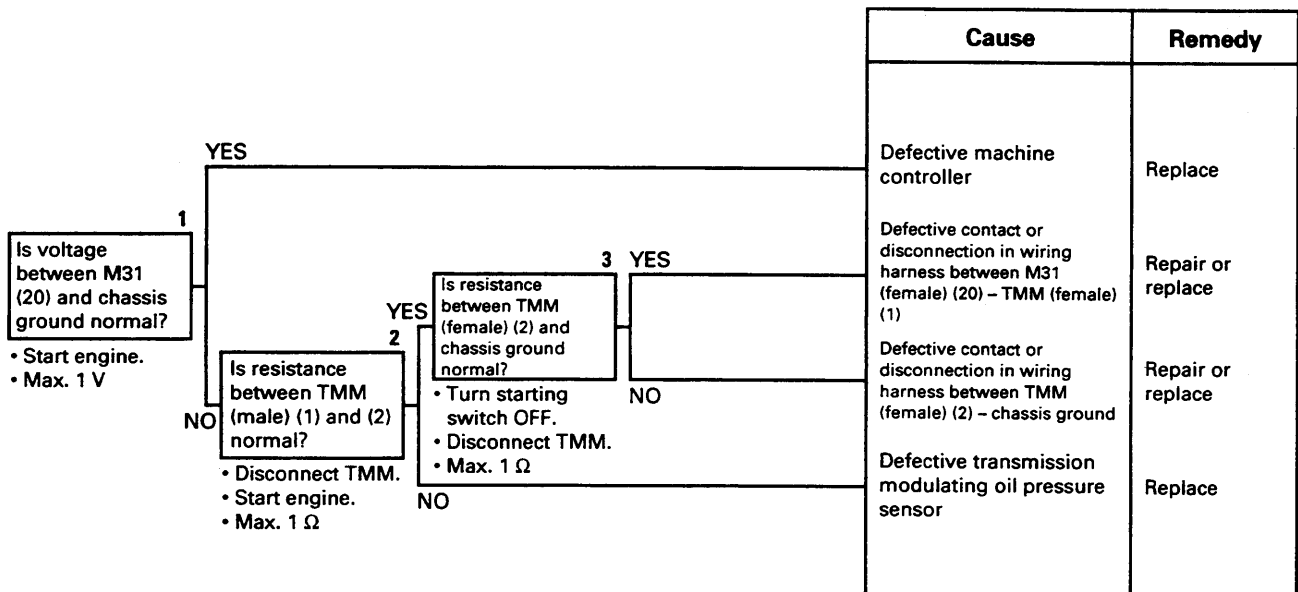

C-13 Related electrical circuit diagram

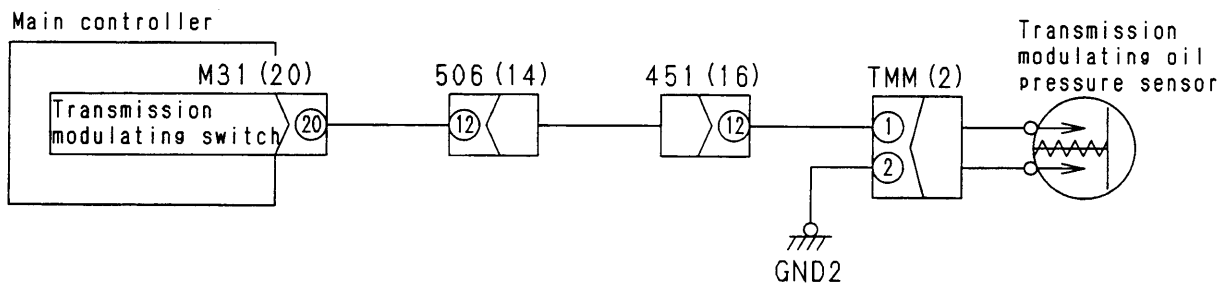

TXD01101

C-23 [E0307] Short circuit in blade left tilt oil pressure switch system is displayed

- ★ If the starting switch was turned off after the abnormality occurred, hold the starting switch in the ON position for 60 seconds, and check that the service code displays "E" at the head. (If "P" is displayed, the condition has returned to normal.)
- ★ Before carrying out troubleshooting, check that all the related connectors are properly inserted.
- ★ Always connect any disconnected connectors before going on to the next step.

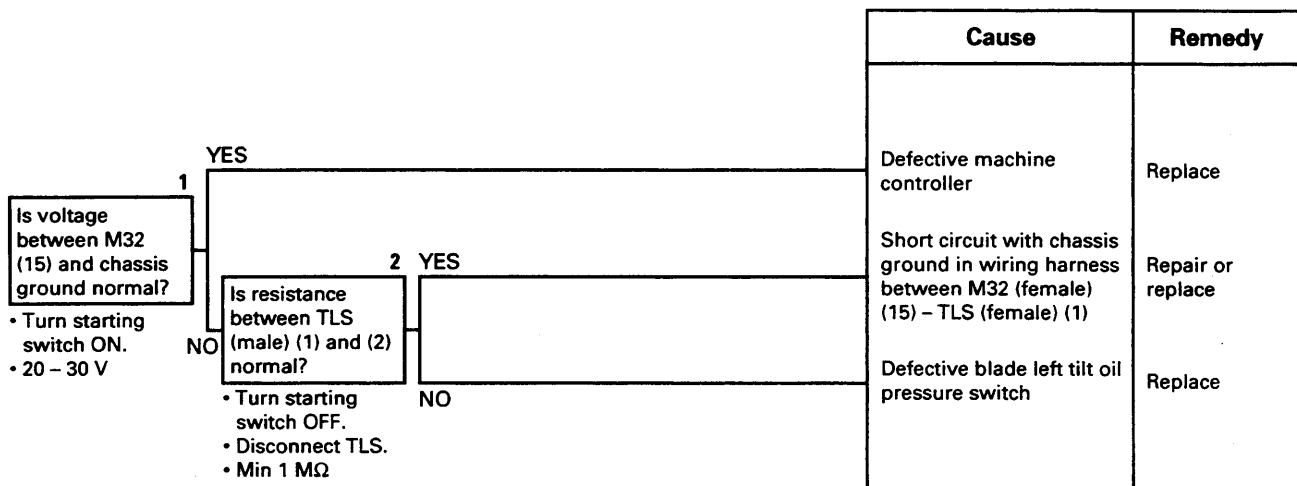

Note: This service code is saved as an error when the blade lever is held in the left tilt position for 60 seconds while the engine is running. When finding out the cause of abnormality, check that the above operation has not been performed during work.

C-23 Related electrical circuit diagram

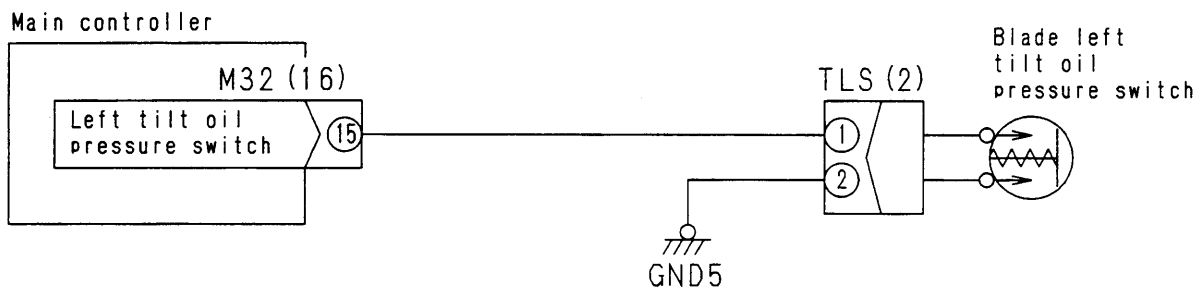

TXD01107

C-33 [E0317] Short circuit in left tilt limit solenoid system is displayed

- ★ If the starting switch was turned off after the abnormality occurred, start the engine and slowly tilt the blade to the left end, and check that the service code displays "E" at the head. (If "P" is displayed, the condition has returned to normal.)
- ★ Before carrying out troubleshooting, check that all the related connectors are properly inserted.
- ★ Always connect any disconnected connectors before going on to the next step.

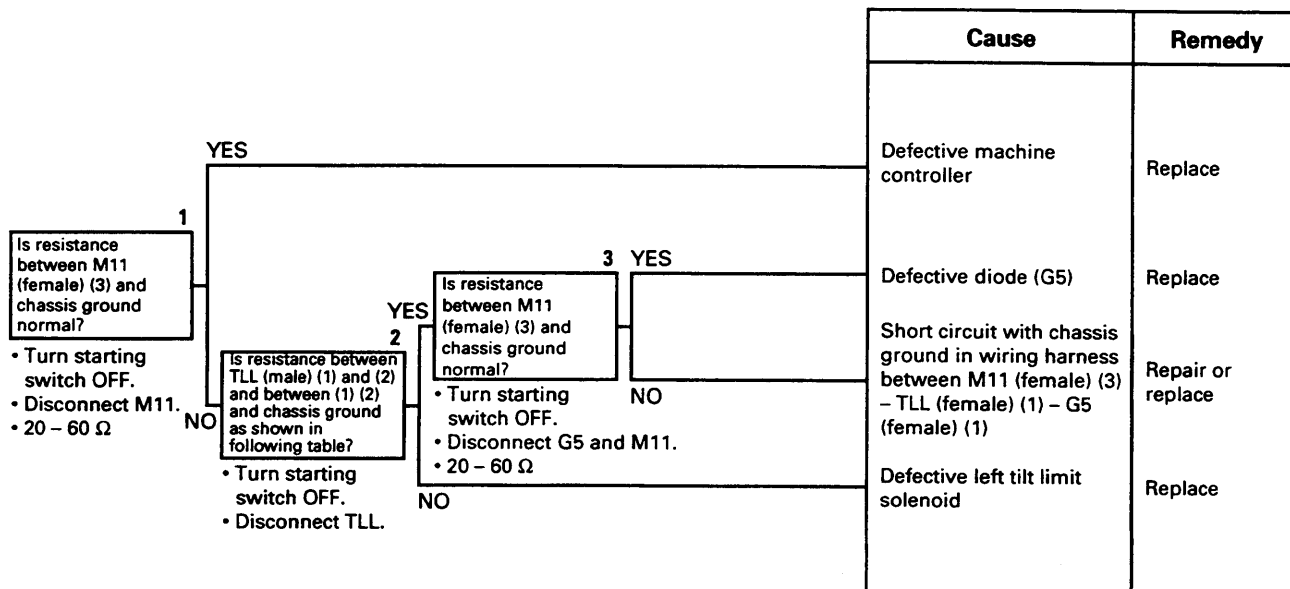

Table

TLL (male)	Resistance
Between (1) - (2)	20 - 60 Ω
Between (1) (2) - chassis	Min. 1 MΩ

C-33 Related electrical circuit diagram

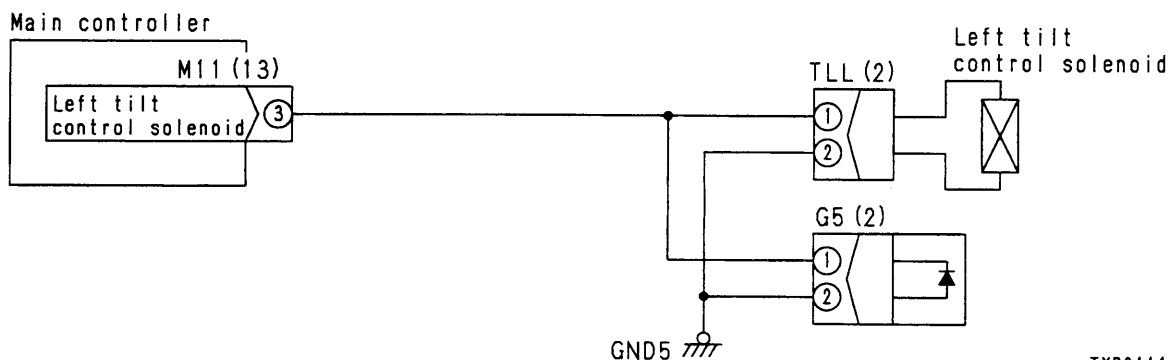

TXD01115

C-43 [E0327] Short circuit in pitch dump assist solenoid system is displayed

- ★ If the starting switch was turned off after the abnormality occurred, start the engine and perform pitch dump operation, and check that the service code displays "E" at the head. (If "P" is displayed, the condition has returned to normal.)
- ★ Before carrying out troubleshooting, check that all the related connectors are properly inserted.
- ★ Always connect any disconnected connectors before going on to the next step.

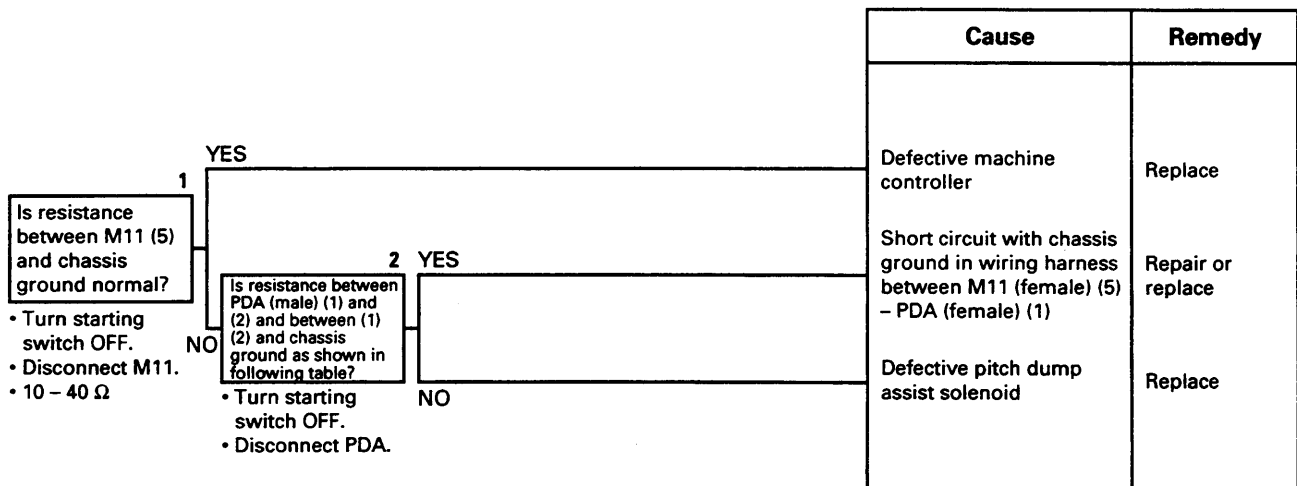

Table

PDA (male)	Resistance
Between (1) – (2)	10 – 40 Ω
Between (1) (2) – chassis	Min. 1 MΩ

C-43 Related electrical circuit diagram

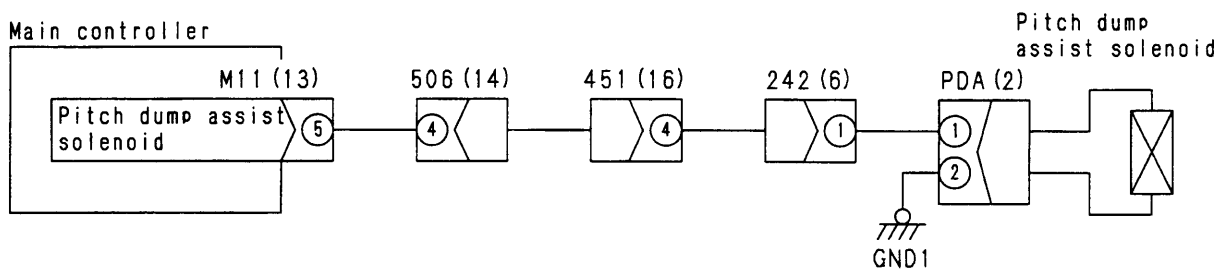

TXD01120

C-53 [E0339] Short circuit in left bottom drain solenoid system is displayed

- ★ If the starting switch was turned off after the abnormality occurred, start the engine and perform pitch operation, and check that the service code displays "E" at the head. (If "P" is displayed, the condition has returned to normal.)
- ★ Before carrying out troubleshooting, check that all the related connectors are properly inserted.
- ★ Always connect any disconnected connectors before going on to the next step.

	Cause	Remedy
<p>1</p> <p>Is resistance between M21 (female) (9) and (19) and between (9) (19) and chassis ground as shown in Table 1?</p> <p>• Turn starting switch OFF. • Disconnect M21.</p> <p>YES → Defective machine controller</p> <p>NO →</p> <p>2</p> <p>Is resistance between LBD (male) (1) and (2) and between (1) (2) and chassis ground as shown in Table 2?</p> <p>• Turn starting switch OFF. • Disconnect LBD.</p> <p>YES →</p> <p>NO →</p> <p>3</p> <p>Is voltage between M21 (female) (19) and chassis ground normal?</p> <p>• Disconnect LBD and M21. • Turn starting switch ON. • Max. 1 V</p> <p>YES → Short circuit with chassis ground or power source in wiring harness between M21 (female) (9) – LBD (female) (1)</p> <p>NO → Short circuit with power source in wiring harness between M21 (female) (19) – LBD (female) (2)</p>	<p>Defective machine controller</p> <p>Short circuit with chassis ground or power source in wiring harness between M21 (female) (9) – LBD (female) (1)</p> <p>Short circuit with power source in wiring harness between M21 (female) (19) – LBD (female) (2)</p> <p>Defective left bottom drain solenoid</p>	<p>Replace</p> <p>Repair or replace</p> <p>Repair or replace</p> <p>Replace</p>

Table 1

M21 (female)	Resistance
Between (9) – (19)	10 – 40 Ω
Between (9) (19) – chassis	Min. 1 MΩ

Table 2

LBD (male)	Resistance
Between (1) – (2)	10 – 40 Ω
Between (1) (2) – chassis	Min. 1 MΩ

C-53 Related electrical circuit diagram

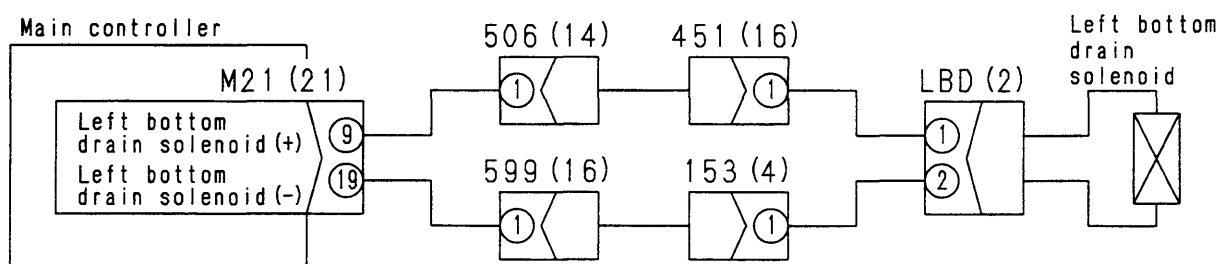

TVD01161

C-64 [E0610] Short circuit in backup alarm relay system is displayed

- ★ If the starting switch was turned off after the abnormality occurred, start the engine and turn the joystick to the REVERSE position, and check that the service code displays "E" at the head. (If "P" is displayed, the condition has returned to normal.)
- ★ Before carrying out troubleshooting, check that all the related connectors are properly inserted.
- ★ Always connect any disconnected connectors before going on to the next step.

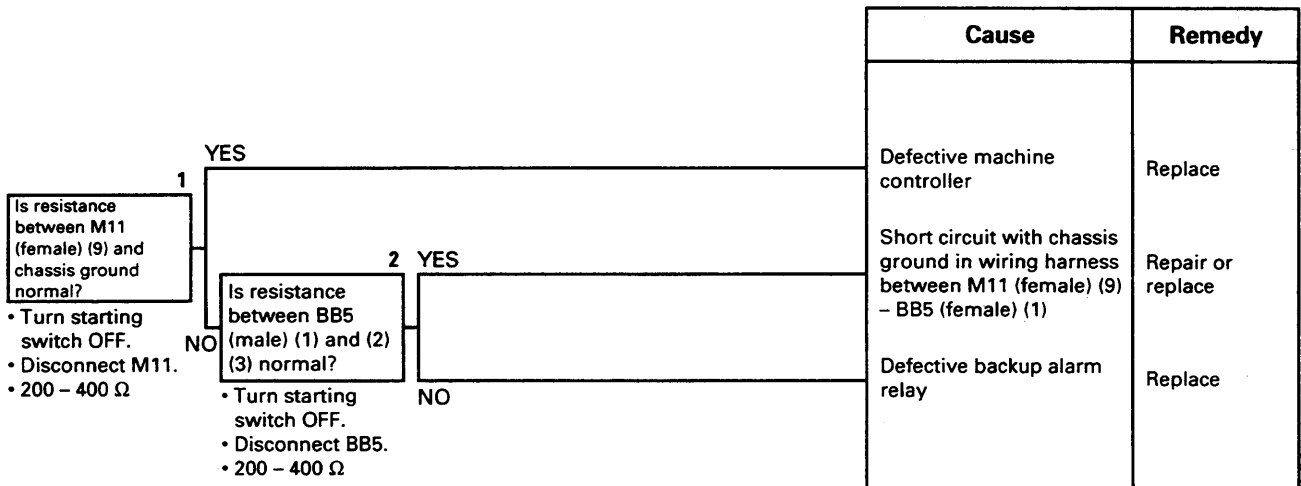

C-64 Related electrical circuit diagram

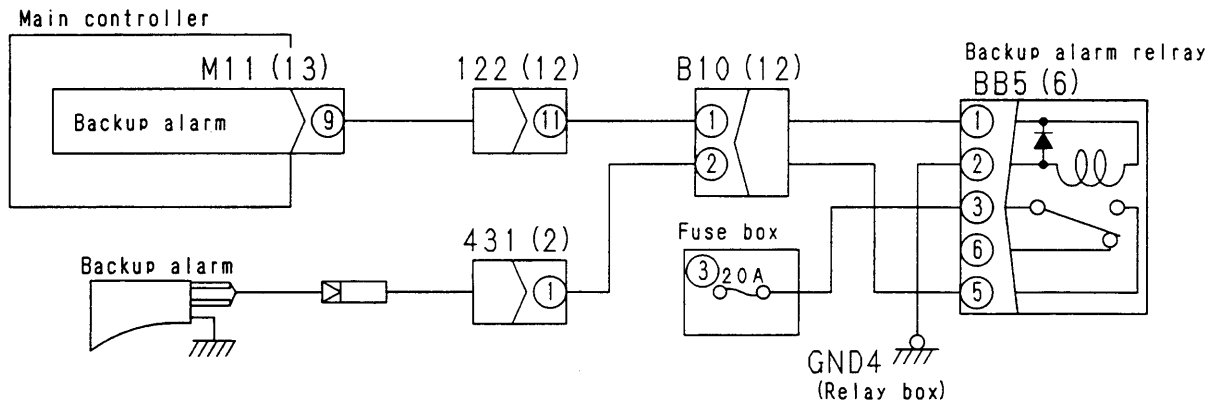

TV001128

C-74 Backup alarm does not sound or keeps sounding

- ★ Check that any service code is not displayed. (If any service code is displayed, check according to it.)
- ★ Before carrying out troubleshooting, check that all the related connectors are properly inserted.
- ★ Always connect any disconnected connectors before going on to the next step.

a) Backup buzzer does not sound

- ★ Check that fuse 3 is not broken. (If it is broken, check the circuit related to it for short circuit with chassis ground.)

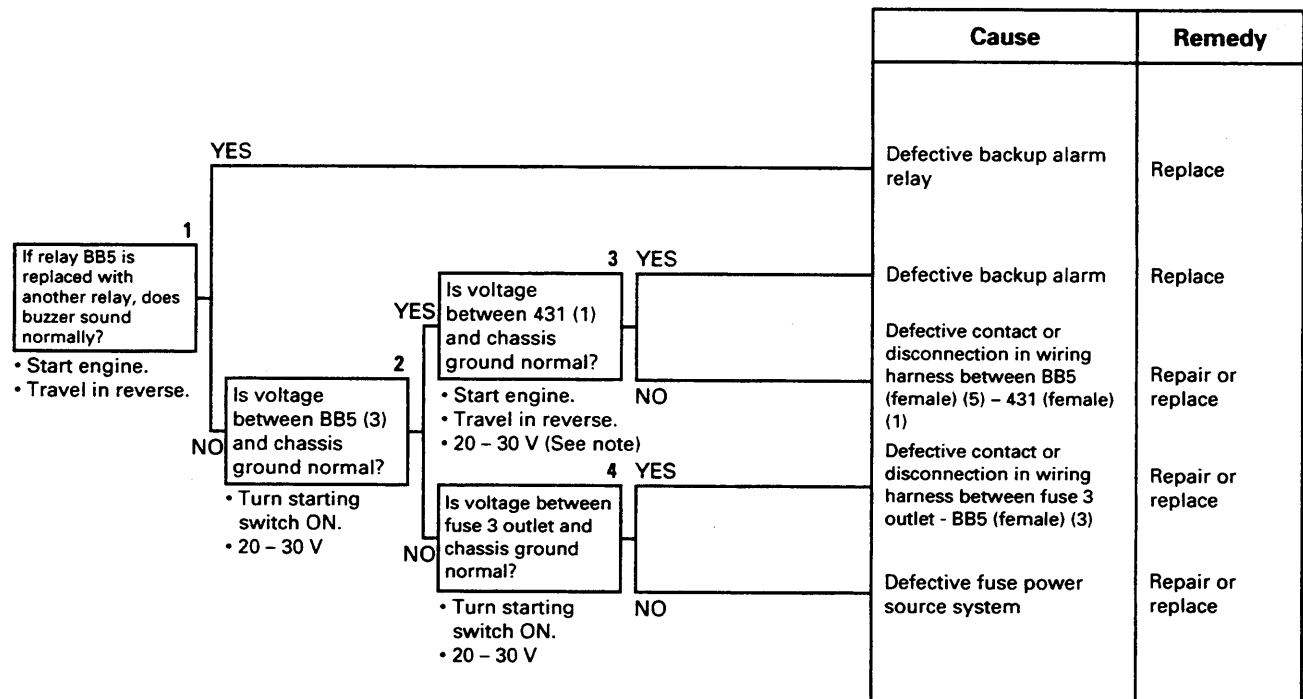

Note: The voltage fluctuates at the interval of about 1 second between 20 - 30V and 1V.

b) Backup buzzer keeps sounding

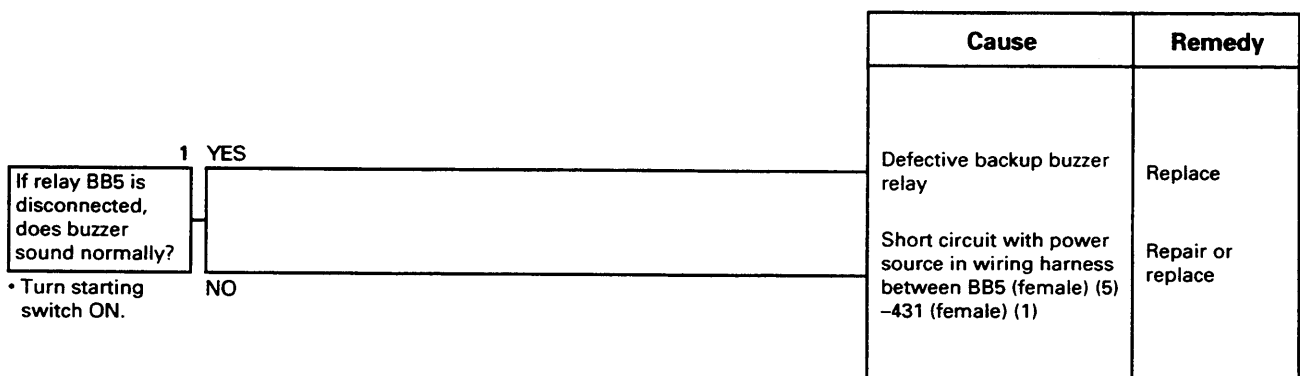

CLICK HERE TO **DOWNLOAD** THE COMPLETE MANUAL

- Thank you very much for reading the preview of the manual.
- You can download the complete manual from: www.heydownloads.com by clicking the link below



- Please note: If there is no response to CLICKING the link, please download this PDF first and then click on it.

CLICK HERE TO **DOWNLOAD** THE COMPLETE MANUAL

H-3 Machine does not move at any gear speed

★ Check that the power train oil level is normal. (If insufficient, supply new oil.)

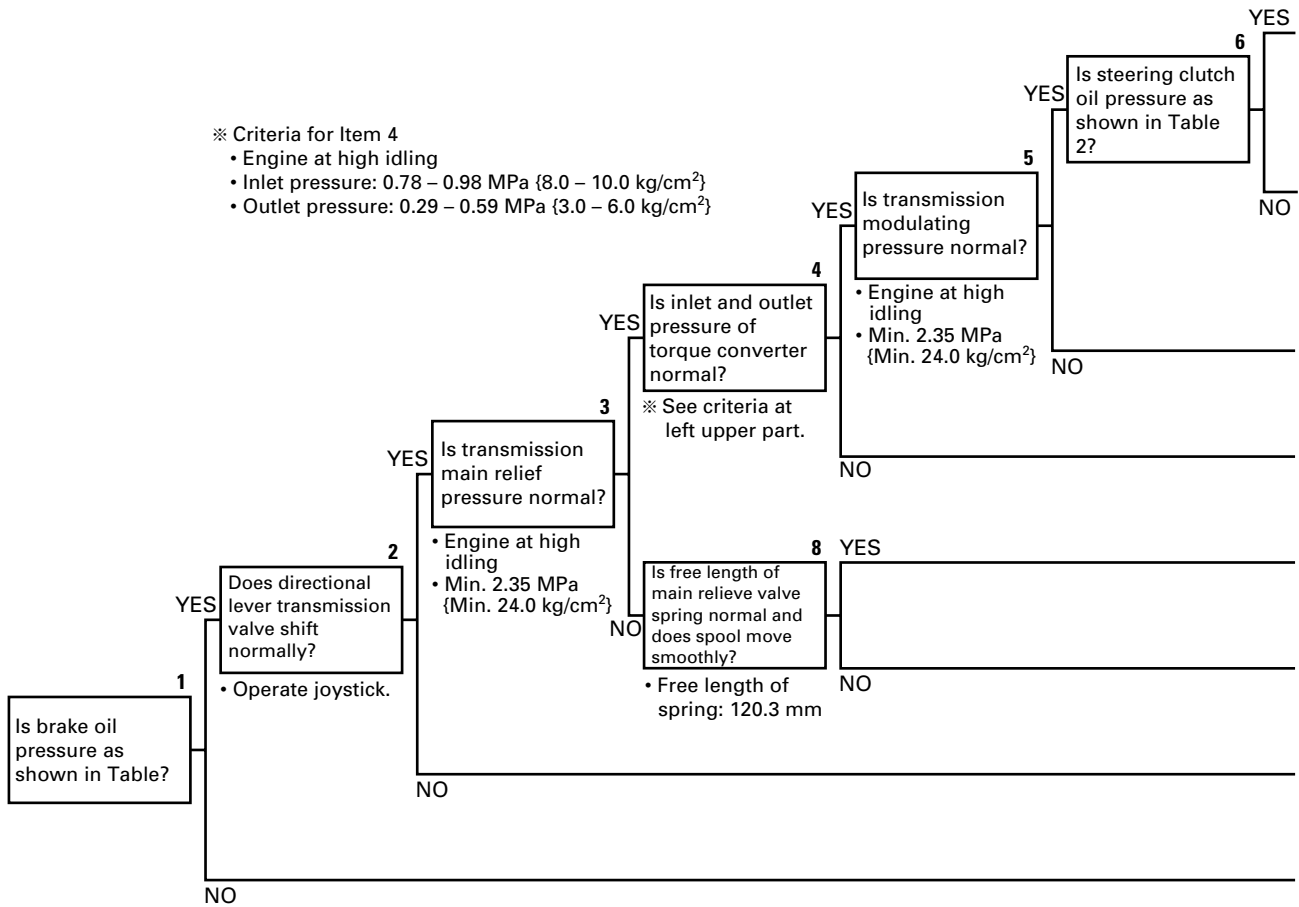
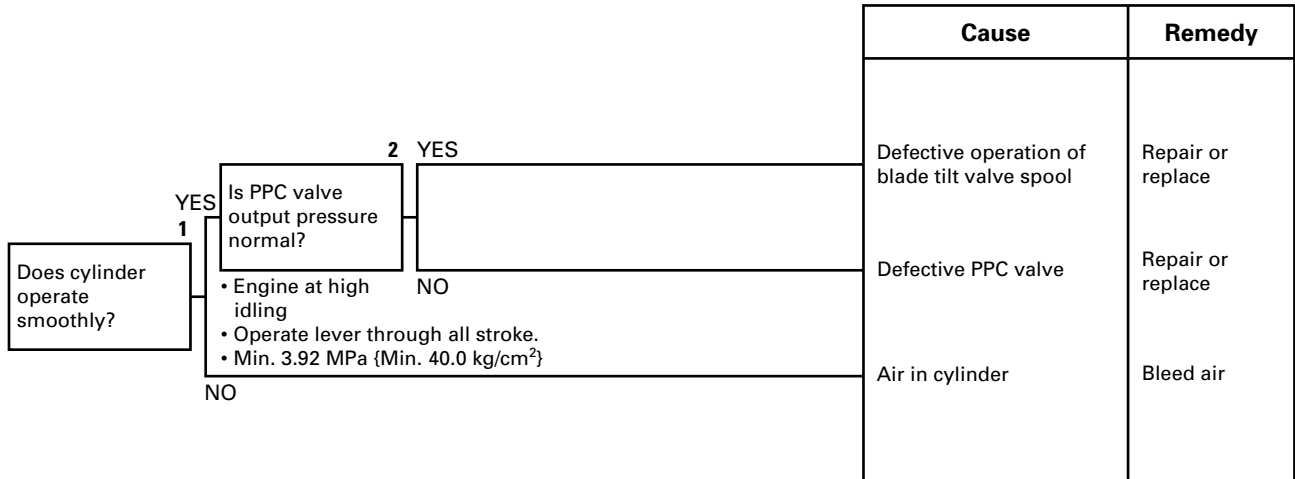

Table 1

Measuring condition			Brake oil pressure (MPa {kg/cm ² })	
			Left	Right
Brake pedal	Released	Engine at low idling	Min. 2.16 {Min. 22.0}	Min. 2.16 {Min. 22.0}
		Engine at high idling	Min. 2.26 {Min. 23.0}	Min. 2.26 {Min. 23.0}
	Depressed	Engine at low idling	0 {0}	0 {0}
		Engine at high idling	0 {0}	0 {0}

H-15 Blade tilt speed is slow or lacks power

- ★ Check that the hydraulic oil level is normal. (If insufficient, supply new oil.)
- ★ Check that the hydraulic drift of the blade tilt is normal. (If not, go to H-20.)
- ★ Check that the blade has not been modified.



H-16 Blade pitch does not work

Dual tilt specification



Superdozer specification

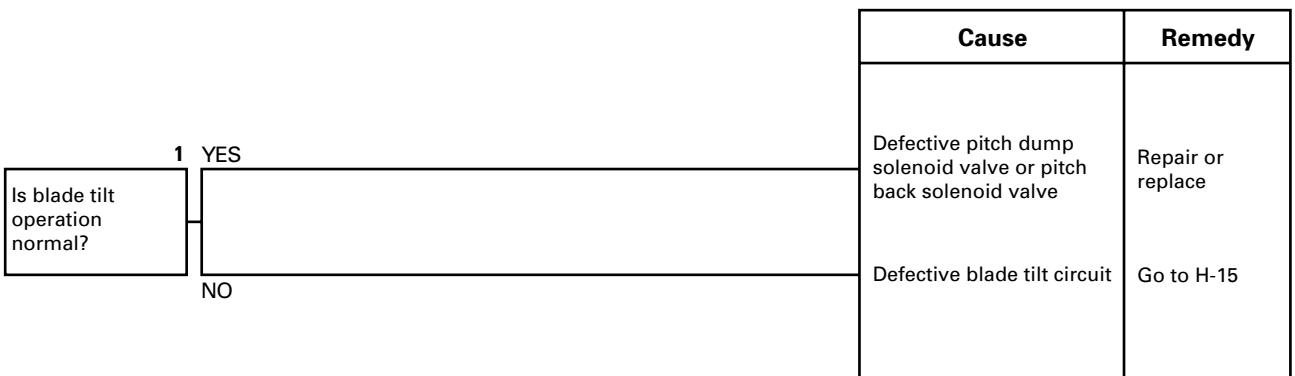

M-2 [E0121] Short circuit in caution buzzer system is displayed

- ★ If the starting switch was turned off after the abnormality occurred, turn the starting switch on and check that the service code displays "E" at the head. (If "P" is displayed, the condition has returned to normal.)
- ★ Before carrying out troubleshooting, check that all the related connectors are properly inserted.
- ★ Always connect any disconnected connectors before going on to the next step.

		Cause	Remedy	
<p>1</p> <p>Is resistance between 217 (buzzer end) normal?</p> <ul style="list-style-type: none"> • Turn starting switch OFF. • Disconnect 217. • Min. 200 Ω 	YES	<p>2 YES</p> <p>Is voltage between CN2 (female) (8) and chassis ground normal?</p> <ul style="list-style-type: none"> • Disconnect 217, CN2. • Turn starting switch ON. • Max. 1 V 	Defective monitor panel (caution module)	Replace
	NO		Short circuit with power source in wiring harness between CN2 (female) (8) and 217	Repair or replace
	NO		Defective caution buzzer	Replace

M-2 Related electrical circuit diagram

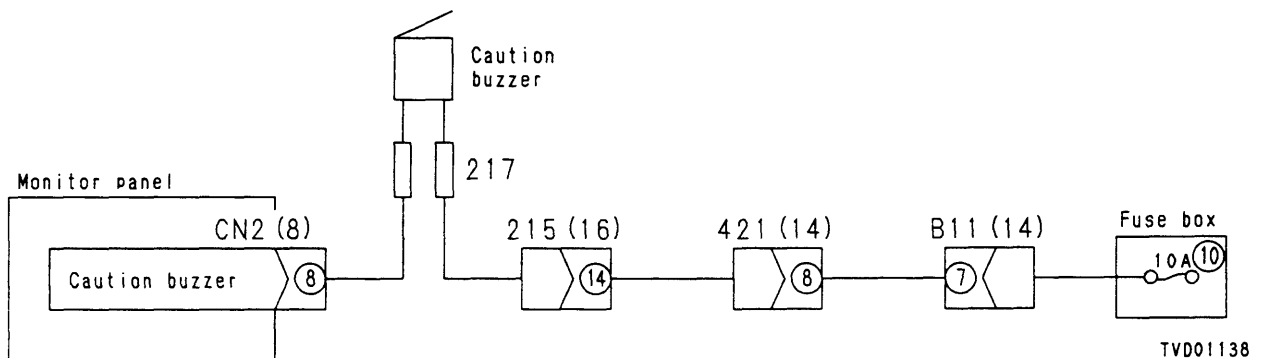

b) Alternator system

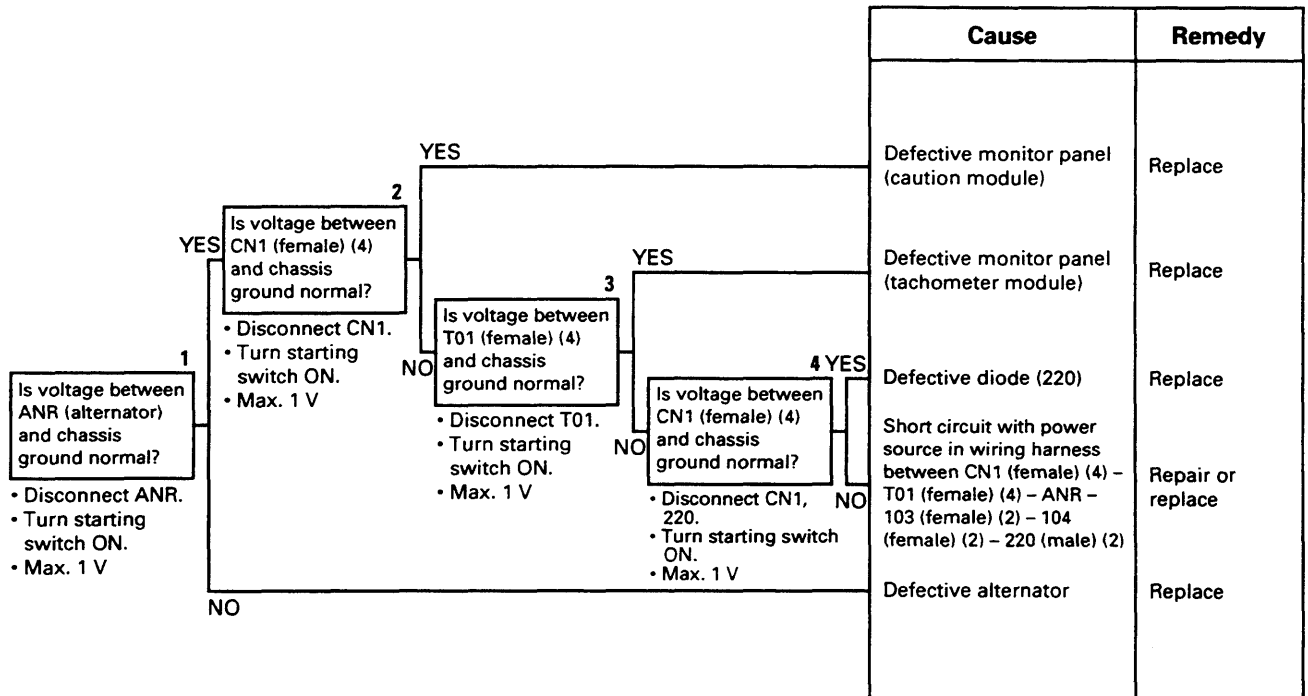

M-11 b) Related electrical circuit diagram

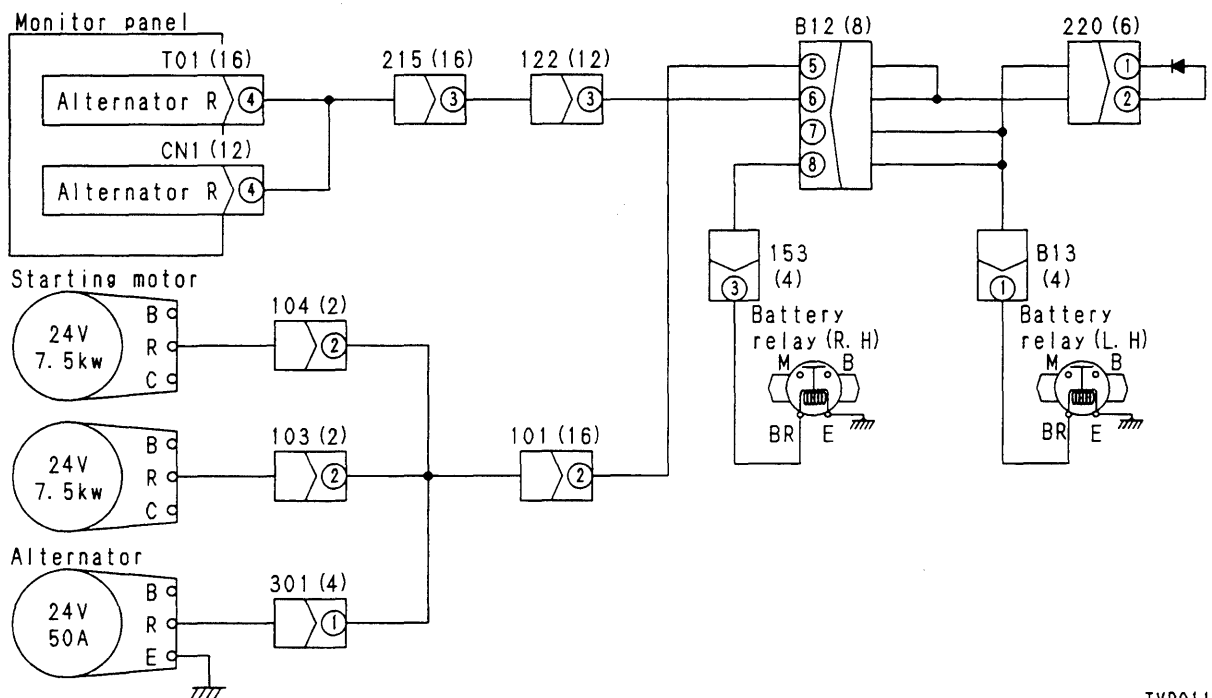

TVD01144

M-15 Abnormality in caution lamp

- ★ Check that any service code is not displayed. (If any one is displayed, check according to it.)
- ★ Before carrying out troubleshooting, check that all the related connectors are properly inserted.
- ★ Always connect any disconnected connectors before going on to the next step.

a) Caution item flashes but caution lamp does not flash, or caution lamp does not light up for 2 seconds after starting switch is turned ON

- ★ Check that fuse 10 is normal before starting troubleshooting.
(If it is blown, check for short circuit with the ground in the wiring harness related to it.)

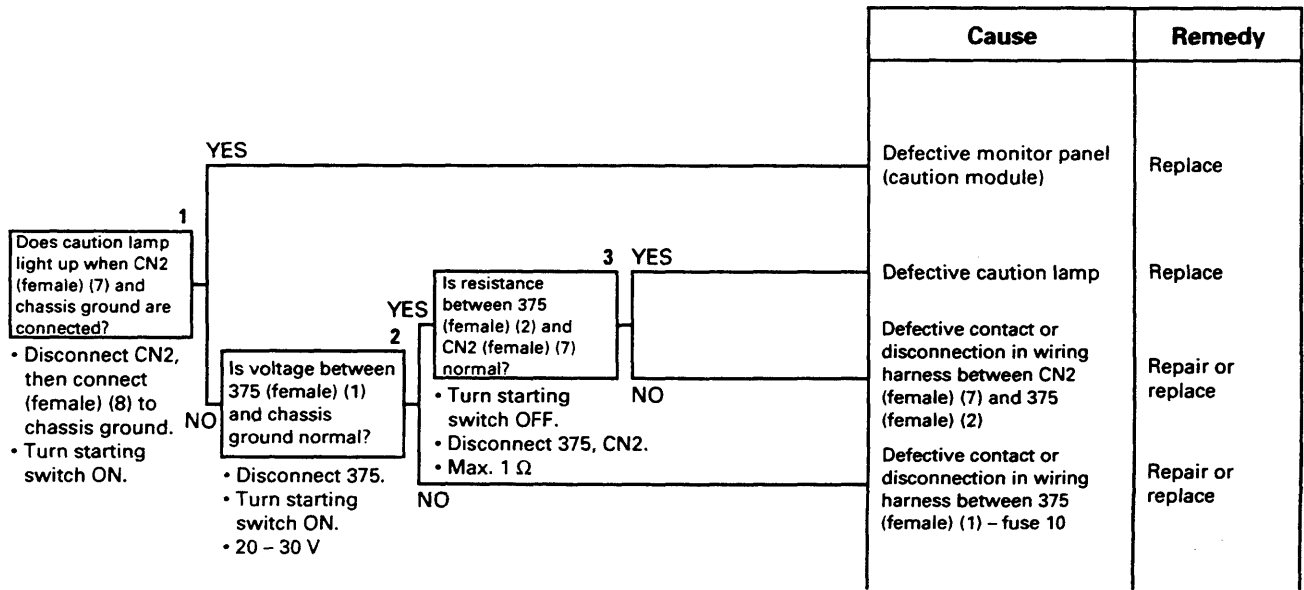

b) No abnormality is displayed on monitor but caution lamp lights up

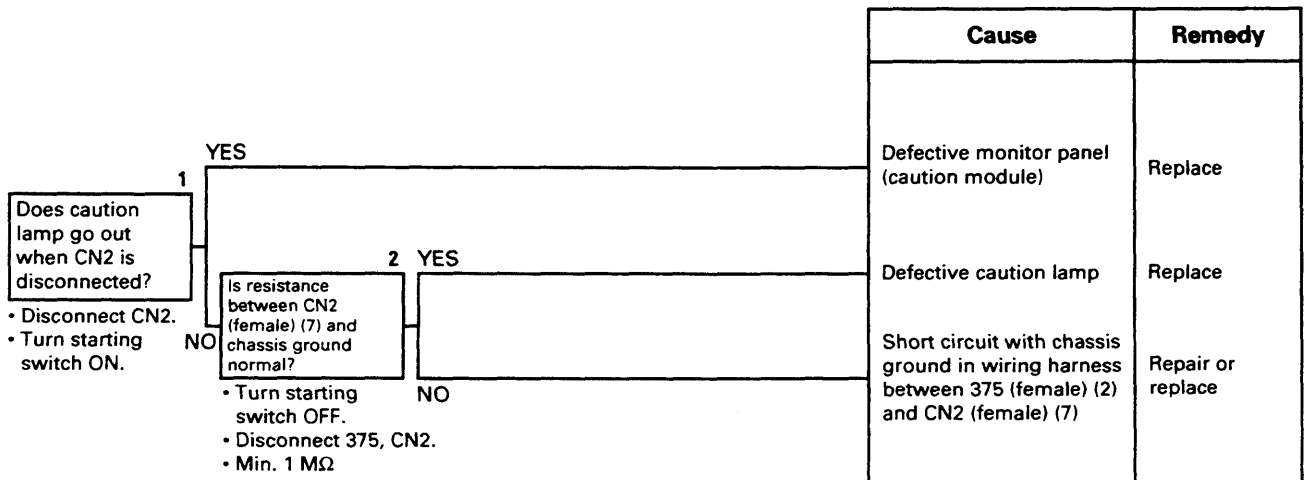

M-21 Related electrical circuit diagram

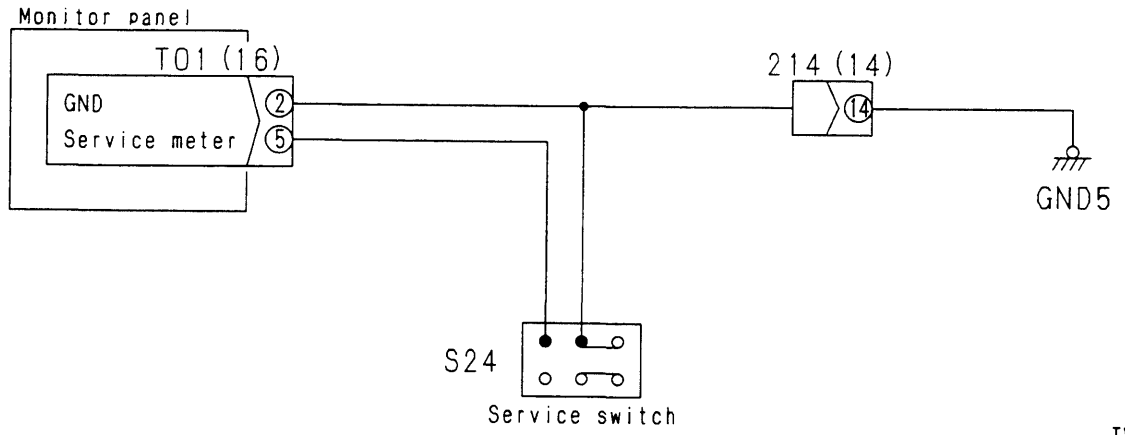

TVD01151

M-26 Windshield wiper and window washer do not work

- ★ Before carrying out troubleshooting, check that all the related connectors are properly inserted.
- ★ Always connect any disconnected connectors before going on to the next step.

a) Any one of windshield wiper and window washers does not work

	Cause	Remedy
	Defective contact or disconnection in wiring harness between battery relay terminal M – fuse box inlet	Repair or replace

b) Front windshield wiper does not work

- ★ Check that fuse 5 is normal. (If it is broken, check the circuit related to it for short circuit with chassis ground.)

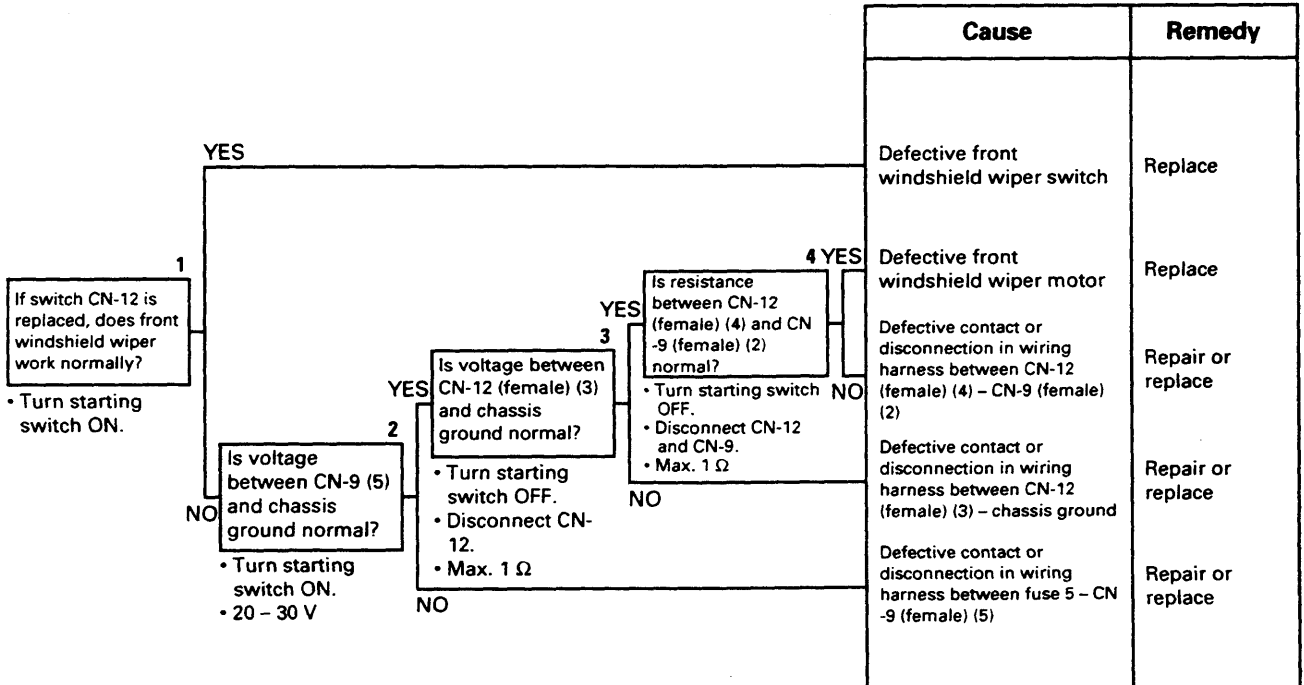

30 DISASSEMBLY AND ASSEMBLY

METHOD OF USING MANUAL	30- 3	TORQFLOW TRANSMISSION ASSEMBLY	
PRECAUTIONS WHEN CARRYING OUT OPERATION	30- 6	Removal and Installation	30- 79
SPECIAL TOOL LIST	30- 8	Disassembly and Assembly	30- 80
SKETCHES OF SPECIAL TOOLS	30-15	STEERING CASE ASSEMBLY	
ENGINE OIL COOLER ASSEMBLY		Disassembly and Assembly	30-100
Removal and Installation	30-23	STEERING CLUTCH, BRAKE ASSEMBLY	
FUEL INJECTION PUMP ASSEMBLY		Disassembly and Assembly	30-108
Removal and Installation	30-24	TRANSFER GEAR HOUSING ASSEMBLY	
AFTERCOOLER CORE ASSEMBLY		Disassembly and Assembly	30-116
Removal and Installation	30-25	POWER TRAIN PUMP ASSEMBLY	
NOZZLE HOLDER ASSEMBLY		Removal and Installation	30-120
Removal and Installation	30-27	SCAVENGING PUMP ASSEMBLY	
ENGINE FRONT SEAL		Removal and Installation	30-121
Removal and Installation	30-28	TORQUE CONVERTER OIL COOLER	
ENGINE REAR SEAL		Removal and Installation	30-122
Removal and Installation	30-30	TORQUE CONVERTER VALVE ASSEMBLY	
CYLINDER HEAD ASSEMBLY		Removal and Installation	30-123
Removal and Installation	30-33	Disassembly and Assembly	30-124
FUEL TANK ASSEMBLY		TRANSMISSION CONTROL VALVE ASSEMBLY	
Removal and Installation	30-37	Removal and Installation	30-127
MAIN RADIATOR ASSEMBLY		Disassembly and Assembly	30-130
Removal and Installation	30-38	STEERING CONTROL VALVE ASSEMBLY	
SUB RADIATOR ASSEMBLY		Removal and Installation	30-135
Removal and Installation	30-40	Disassembly and Assembly	30-136
RADIATOR GUARD ASSEMBLY		FINAL DRIVE ASSEMBLY	
Removal and Installation	30-41	Removal and Installation	30-140
ENGINE ASSEMBLY		Disassembly and Assembly	30-141
Removal and Installation	30-43	TRACK FRAME ASSEMBLY	
DAMPER ASSEMBLY		Removal and Installation	30-158
Removal and Installation	30-47	IDLER ASSEMBLY	
Disassembly and Assembly	30-49	Disassembly and Assembly	30-161
POWER TRAIN UNIT ASSEMBLY		RECOIL SPRING ASSEMBLY	
Removal and Installation	30-52	Removal and Installation	30-165
PTO, TORQUE CONVERTER ASSEMBLY		Disassembly and Assembly	30-171
Removal and Installation	30-56		
Disconnection and connection	30-59		
TORQUE CONVERTER ASSEMBLY			
Disassembly and Assembly	30-61		
PTO ASSEMBLY			
Disassembly and Assembly	30-72		

Component	Symbol	Part No.	Part Name	Nece- ssity	Q'ty	New/ remodel	Sketch	Nature of work, remarks	
Disassembly and assembly of bogie	17	790-101-5201	Push tool kit	■	1			Press fitting of bushing	
		790-101-5341	• Plate		1				
		790-101-5221	• Grip		1				
		01010-51225	• Bolt		1				
	20	790-601-1000	Oil pump	■	1			Filling with oil	
	21	791-630-1860	Bracket	■	1			Removal of No. 1 bogie assembly	
		791-630-1870	Bracket	■	1				
		791T-830-1510	Spacer	■	2	N	○		
		19M-09-12850	Bolt	■	2				
		01643-33380	Washer	■	2				
	22	1	791-630-1850	Adapter	■	1	R	Removal of No. 1 bogie pin	
		2	791-830-1490	Spacer	■	1	N		
		3	796T-670-1140	Plate	■	1			○
		4	790-101-2540	Washer	■	1			
		5	791-112-1180	Nut	■	1			
		6	791-520-4140	Screw	■	1			
		7	01010-81245	Bolt	■	2			
		8	01643-31232	Waher	■	2			
		9	790-101-2102	Puller(294kN(30ton))	■	1			
		10	790-101-1102	Pump	■	1			
	23	1	791-830-1410	Push tool	■	1	N	Removal of No. 1 bogie collar	
		2	791-830-1420	Plate	■	1	N		
		3	791-830-1430	Plate	■	1	N		
		4	791-630-1840	Stud	■	3			
		5	791-830-1450	Spacer	■	1	N		
		6	791-830-1440	Plate	■	1	N		
		7	790-434-1060	Screw	■	1			
		8	01580-13024	Nut	■	3			
		9	01643-33080	Washer	■	1			
		10	790-101-4000	Puller(490kN(50ton))	■	1			
		11	791-679-1120	Plate	■	1			
		12	790-101-1102	Pump	■	1			
24	791-630-1780	Installer	■	1			Installation of No. 1 bogie floating seal		
25	791T-830-1460	Guide	■	1	N	○	Press fitting of No. 1 bogie cartridge pin		

Component	Symbol	Part No.	Part Name	Necessity	Q'ty	New/remodel	Sketch	Nature of work, remarks	
Disassembly, assembly of hydraulic cylinders	3	790-201-1500	Push tool kit	■	1			Press fitting of dust seal	
		790-201-1670	• Plate		1			• Blade lift	
		790-201-1680	• Plate		1			• Ripper lift	
		790-201-1690	• Plate		1			• Blade tilt (Standard specification) • Blade pitch (Superdozer specification) • Ripper tilt	
		790-201-1530	• Plate		1			• Pin puller	
		790-101-5201	• Grip		1			—	
		01010-50816	• Bolt		1			—	
	4	790-720-1000	Expander	■	1			Installation of piston rings of all cylinders	
	5	796-720-1690	Ring	■	1			Blade lift	
		07281-01919	Clamp	■	1			(Standard specification)	
		796-720-1690	Ring	■	1			Blade lift	
		07281-02169	Clamp	■	1			(Superdozer specification)	
		796-720-1710	Ring	■	1			Ripper tilt, lift	
		07281-02709	Clamp	■	1			Blade tilt (Standard specification) Blade pitch (Superdozer specification)	
		796-720-1630	Ring	■	1			Pin puller	
	07281-00709	Clamp	■	1					
	6	790-102-2303	Wrench	■	1			Removal, installation of pin puller cylinder head	
	Parts related to air conditioner	X	799-703-1200	Service tool kit	■	1			Charging with refrigerant gas
			799-703-1100	Vacuum pump	■	1			(100V specification)
			799-703-1110	Vacuum pump	■	1			(200V specification)
799-703-1120			Vacuum pump	■	1			(240V specification)	
799-703-1400			Gas leak detector	■	1			—	

L20 Spacer

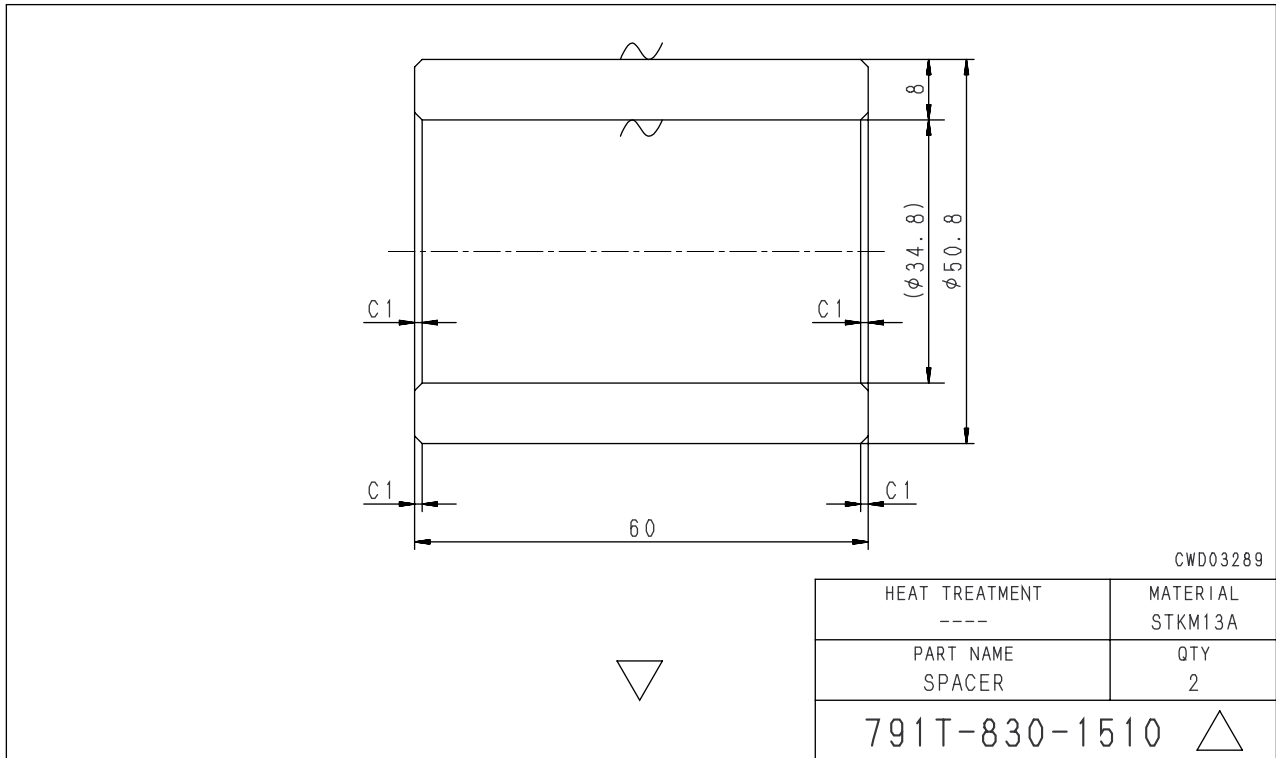

L21 Bar

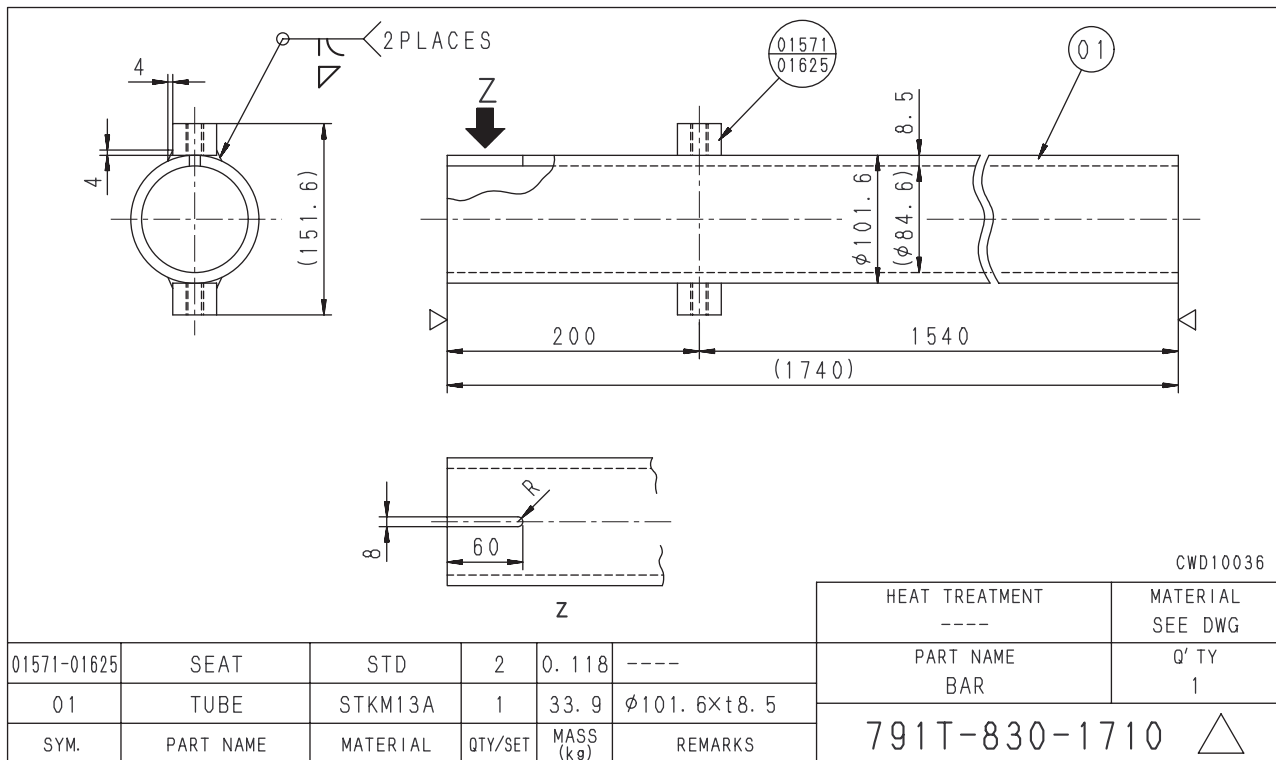

- 2) When installing oil seal at different mounting position
- i) Fill approx. 50 – 80% of lip portion at top of circumference of seal (2) with lithium grease.
 - ii) Using tool **A1**, press fit seal (2).
 - iii) After press fitting, check mounting dimension **b**.
Front seal mounting dimension **b** :
16.2 mm

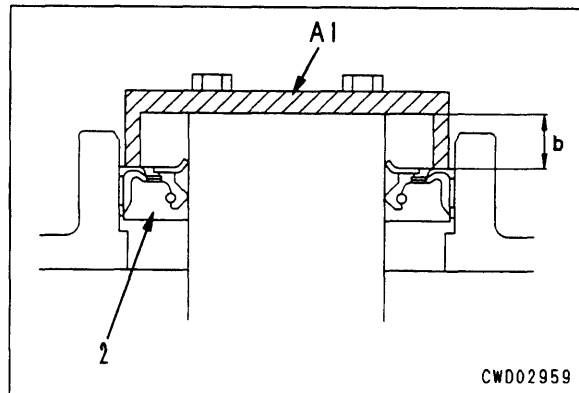

- 3) When there is wear of crankshaft oil seal contact surface
- Procedure for assembling front seal with sleeve
 - i) Coat all of inside surface of sleeve (3) with gasket sealant (LG-7).
 - ii) Using tool **A1**, press fit sleeve (3) to specified position.
Sleeve mounting dimension **c**: 5 mm
★ Tighten the bolts uniformly.
★ After press fitting the sleeve, wipe off all the gasket sealant that is forced out.
 - iii) Fill approx. 50 – 80% of lip portion at top of circumference of seal (4) with lithium grease.
 - iv) Insert washer ② (01640-22232) between tool **A1** and seal (4), and press fit.
 - v) After press fitting, check mounting dimension **c**.
Front seal mounting dimension **c** :
13 mm

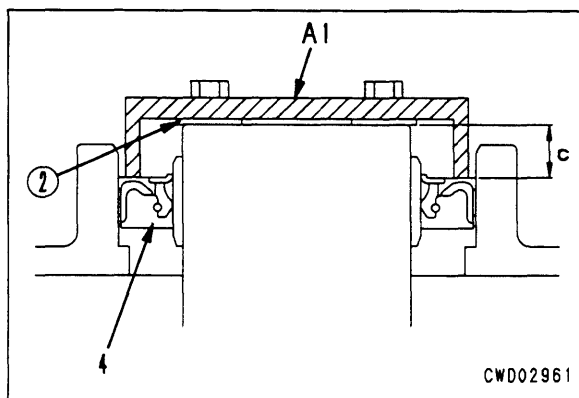
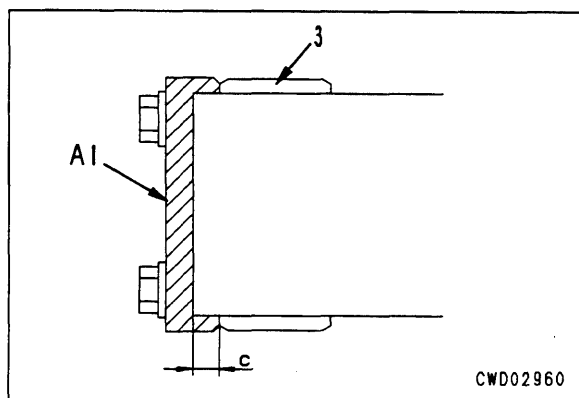

11. Remove covers (13) (left and right).
12. Remove tube (14).
13. Remove bottom mount bolts (15) (left and right).
14. Lift off radiator assembly (11).
 - ★ Be careful not to damage the core when lifting the radiator off.



Radiator assembly : 550 kg

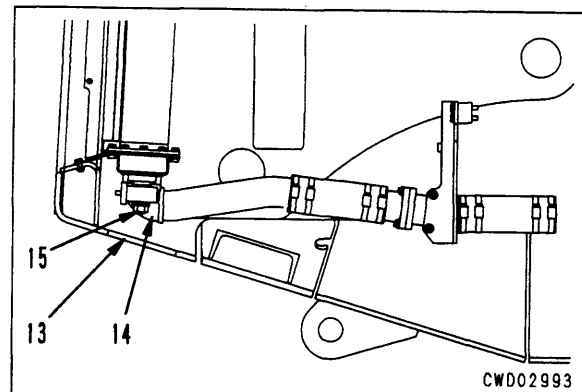

INSTALLATION OF MAIN RADIATOR ASSEMBLY

- Carry out installation in the reverse order to removal.
- **Refilling with water**
Add water to the specified level, and run the engine to circulate the water through the system. Then check the water level again.

DISASSEMBLY OF DAMPER ASSEMBLY

Disassembly of damper assembly

1. Remove bolt (1), then remove flange (2).
2. Remove seal (3).
3. Remove shaft (4).
4. Remove rubber (5).
5. Remove flange (6) from body (7).
6. Remove seal (8).
7. Remove bearing (9).

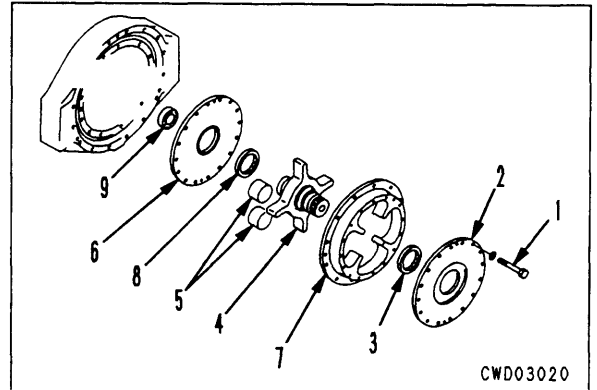

Disassembly of damper cover assembly

8. Remove bearing (10) and seal (11) from cover (12).
9. Remove oil seal (13) from retainer (14).

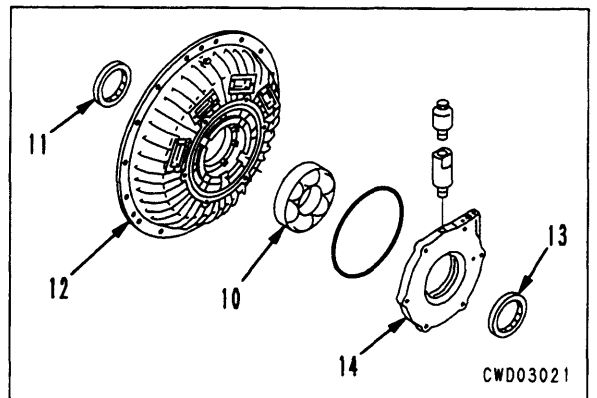

ASSEMBLY OF DAMPER ASSEMBLY

Assembly of damper assembly

1. Using push tool, press fit bearing (9).
 Flywheel pilot portion : Grease (G2-U)
 ★ Fill 50% (approx. 55 g) of clearance a.

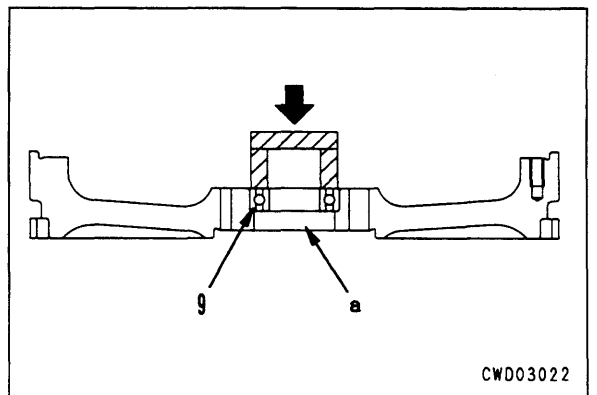

2. Install seal (8) to flange (6), and seal (3) to flange (2).
 ★ Install the seal with the lip facing the inside as shown in the diagram.

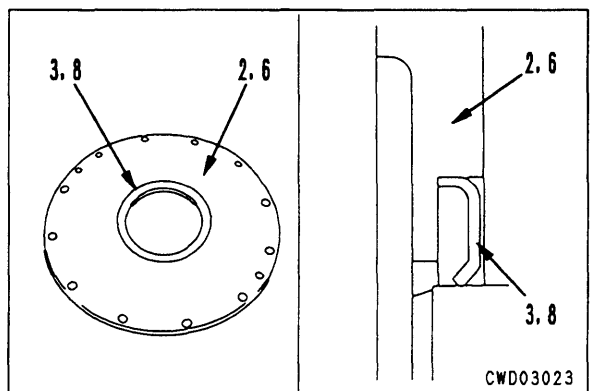

DISCONNECTION OF PTO, TORQUE CONVERTER ASSEMBLY

1. Set PTO and torque converter assembly (1) to tool C.

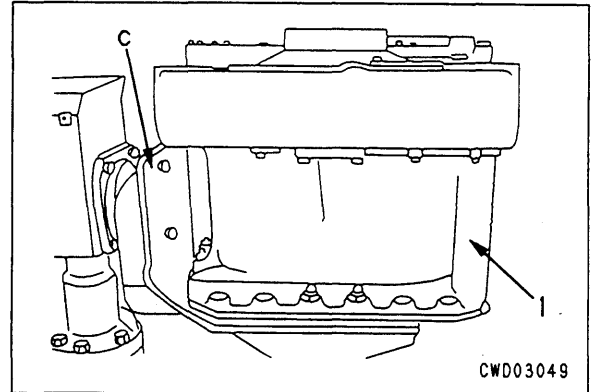

2. Remove coupling assembly (2).
3. Remove cap (3).
 - ★ Remove snap ring (4), then remove the cap.
4. Remove retainer assembly (5). ※ 1
 - ★ Using forcing screws, remove the cover, retainer assembly, and shims.
 - ★ Check the number and thickness of the shims, and keep in a safe place.

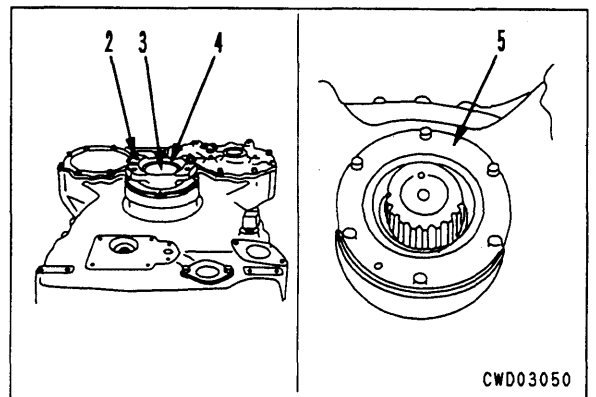

5. Remove oil seal (6). ※ 2
6. Remove spacer (7).
 - ★ Remove snap ring (8), then remove the spacer.

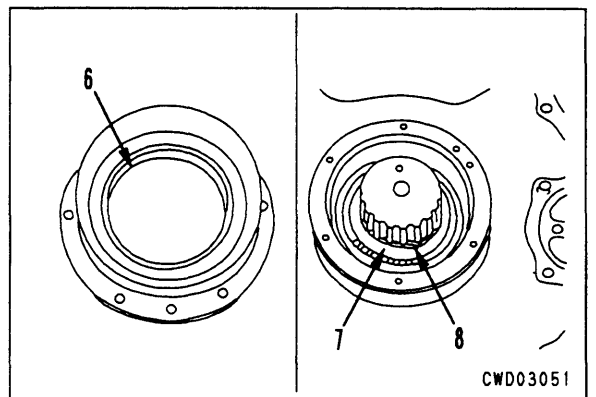

7. Remove PTO assembly (9) and torque converter assembly (10).
 - ★ Using eyebolts ①, raise the PTO assembly, then disconnect it from the torque converter assembly.

kg PTO, torque converter assembly :
850 kg

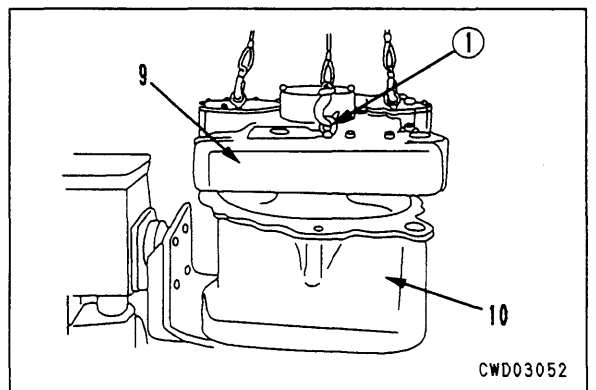

- ii) Assemble race (22) to stator (23), and secure with snap ring (21).
- 2) Install stator assembly (20) to stator shaft, and secure with snap ring (19).

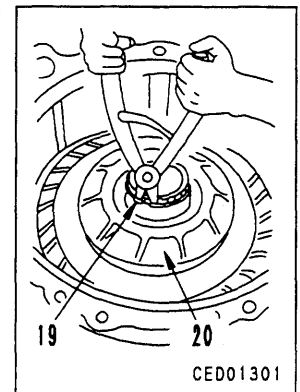
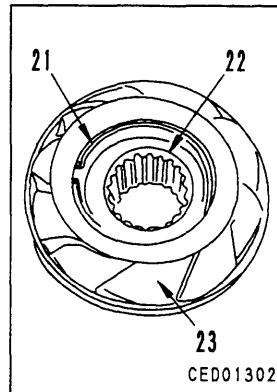

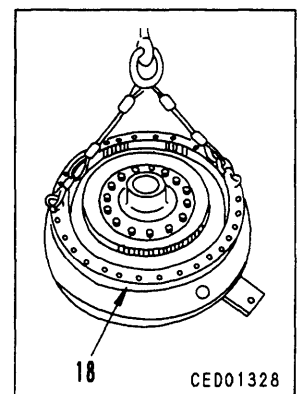
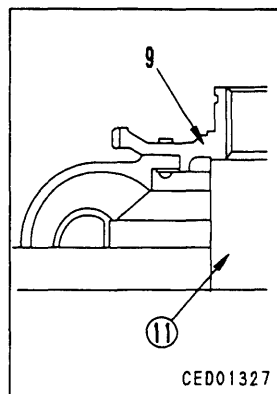

10. Lock-up clutch, drive case assembly

- 1) Assemble lock-up clutch and drive case assembly as follows.
 - i) Set turbine (9) to block (11), and set drive case (18) to turbine.

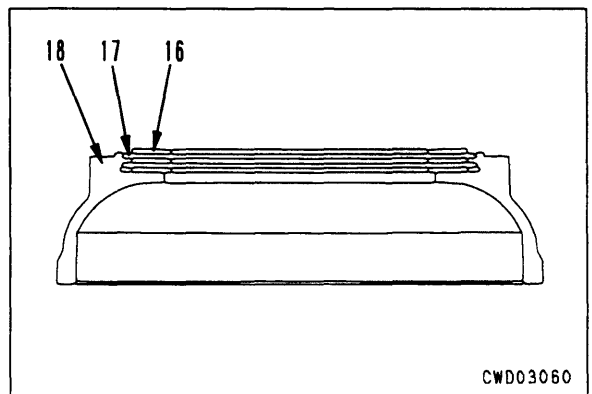

- ii) Install 3 discs (16) and 2 plates (17).



- iii) Install seal ring (14) to housing.
 -  Outer circumference of seal ring : **Grease (G2-LI)**
- iv) Install seal ring (13) to piston.
 -  Outer circumference of seal ring : **Grease (G2-LI)**

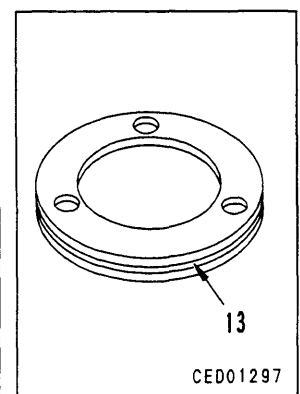
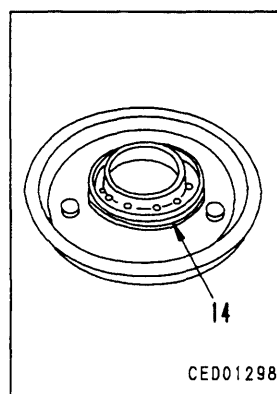

REMOVAL OF TORQFLOW TRANSMISSION ASSEMBLY

- Remove PTO and torque converter assembly. For details, see REMOVAL OF PTO, TORQUE CONVERTER ASSEMBLY.

1. Remove TORQFLOW transmission assembly (1).

※ 1

- ⚠ Sling the transmission assembly, then remove the mounting bolts.

- ★ Using a lever block, raise the transmission horizontally, then remove from the steering.



TORQFLOW transmission assembly:

1,400 kg

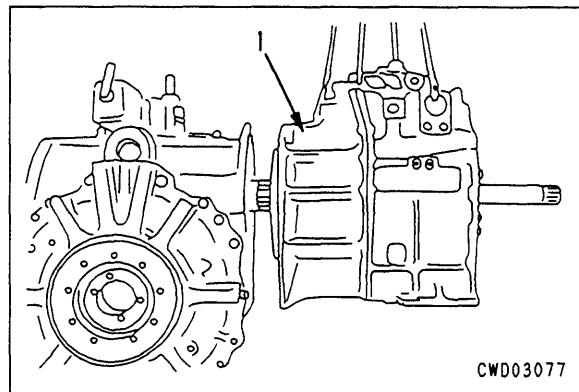

INSTALLATION OF TORQFLOW TRANSMISSION ASSEMBLY

- Carry out installation in the reverse order to removal.

※ 1

- ★ Using a lever block, sling transmission assembly (1) horizontally, align with spline of shaft at steering case end, then install.

ASSEMBLY OF TORQFLOW TRANSMISSION ASSEMBLY

- ★ Wash all parts in clean flushing oil (in particular, oil holes, etc.), then dry them, and check for dirt or damage. Coat the sliding surfaces of all parts with engine oil before installing.
- ★ Set the seal ring with the side taking the pressure facing the housing, then coat with grease (G2-LI) and install uniformly so that it is positioned correctly.
- ★ Align the notches of the oil groove when installing the discs.

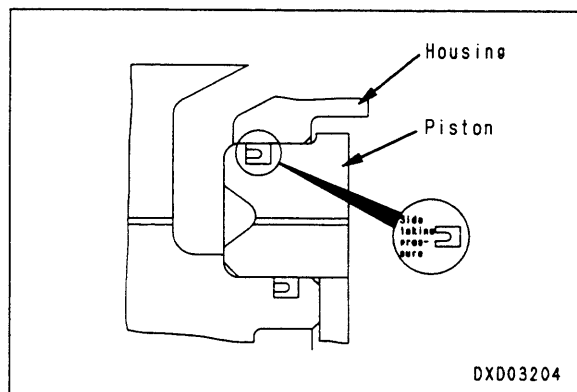

1. Shaft assembly

1) Assemble the shaft assembly as follows.

- i) Install seal ring (126).
- ii) Using push tool, install baring (124).

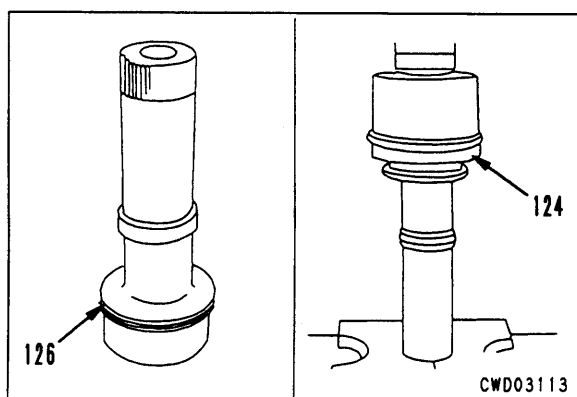

- iii) Install cover (123).
- iv) Install seal ring (122).
- v) Install bearing (121) to cage (133) and secure with snap ring (134).

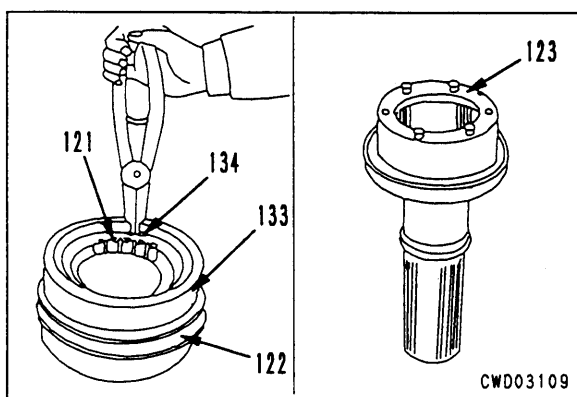

- vi) Using push tool, press fit bearing (120).
- vii) Fit seal ring and install cage (119).

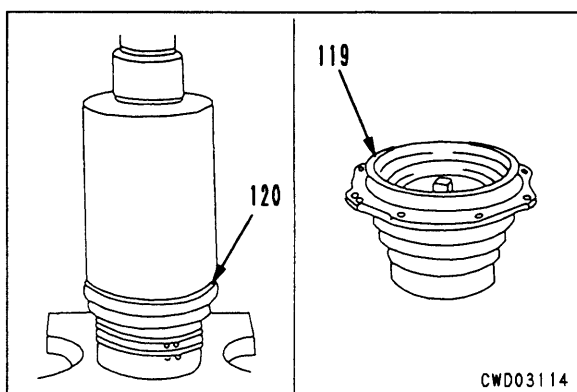

DISASSEMBLY OF STEERING CASE ASSEMBLY

1. Steering valve

- 1) Remove steering valve assembly (1).



Steering valve : 25 kg

- 2) Remove seat (2).

2. Clutch, brake assembly

Using tool E1, sling clutch and brake assembly, then remove mounting bolts, and remove clutch and brake assembly (3).

- ★ Remove the clutch and brake assembly on the opposite side in the same way. When pulling out the clutch and brake assembly, be careful not to damage the discs and plates.

3. Shafts

Remove left and right shafts (4).

4. Lubrication tube

Remove lubrication tube (5).

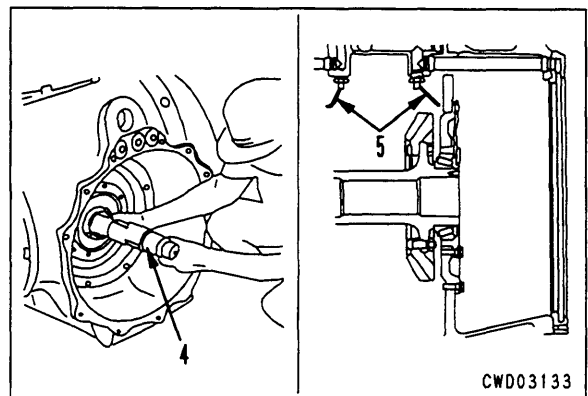
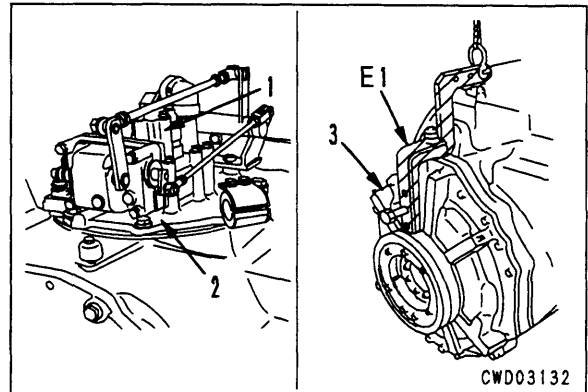

5. Pipes

- 1) Remove left and right pipes (6).
- 2) Remove pipe (7).

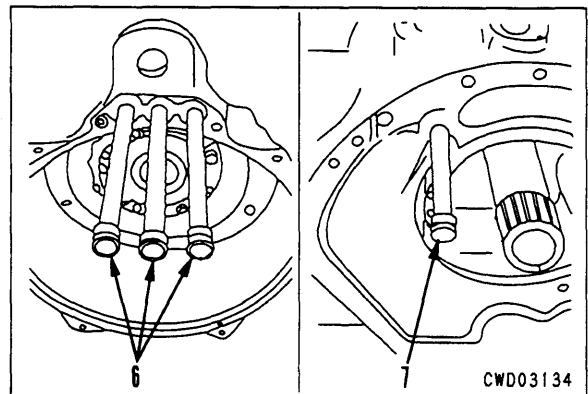

6. Input shaft

- 1) Remove cage assembly (8).
- 2) Remove snap ring, and pull out input shaft (9) from case.

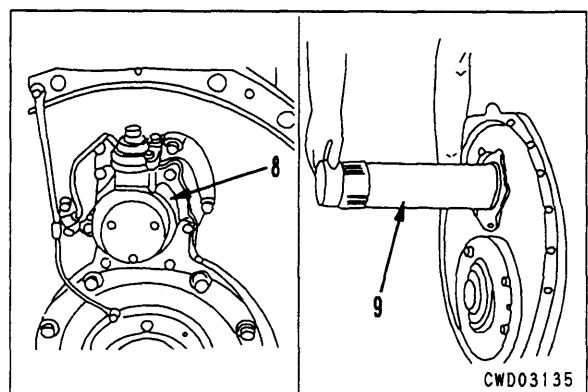

3) Remove outer race (25) from clutch cage.

9. Belleville springs

Remove Belleville springs (26).

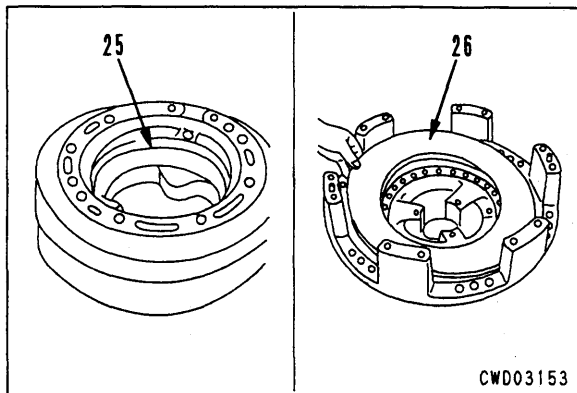

10. Brake hub

- 1) Using eyebolts (5), remove brake hub (27).
- 2) Remove bearing (28) from brake hub.

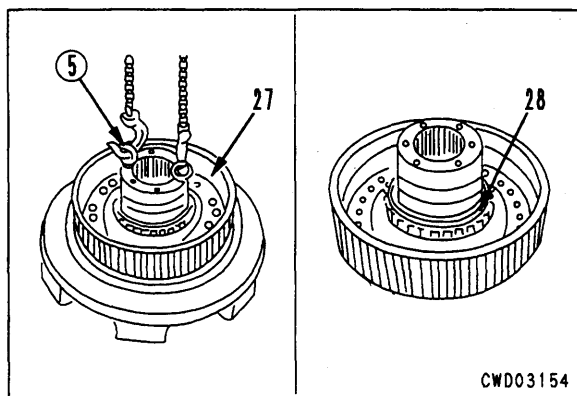

REMOVAL OF POWER TRAIN PUMP ASSEMBLY

1. Remove oil strainer inspection cover at front left of operator's platform.
2. Open undercover. (3rd from front of machine).
3. Remove oil strainer (1).
★ Disconnect coupling (2) and remove strainer mounting bolts.
4. Disconnect hose (3).
5. Lift off power train pump assembly (4).



Power train pump assembly : 60 kg

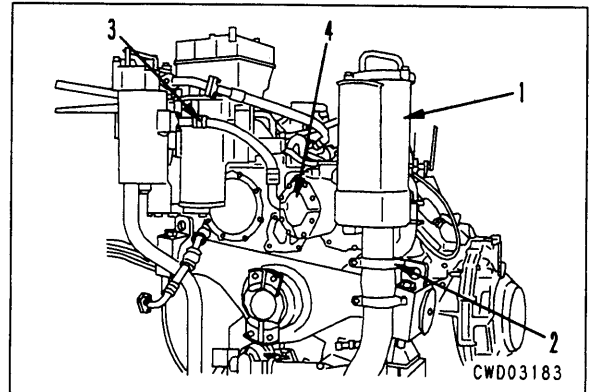

INSTALLATION OF POWER TRAIN PUMP ASSEMBLY

- Carry out installation in the reverse order to removal.

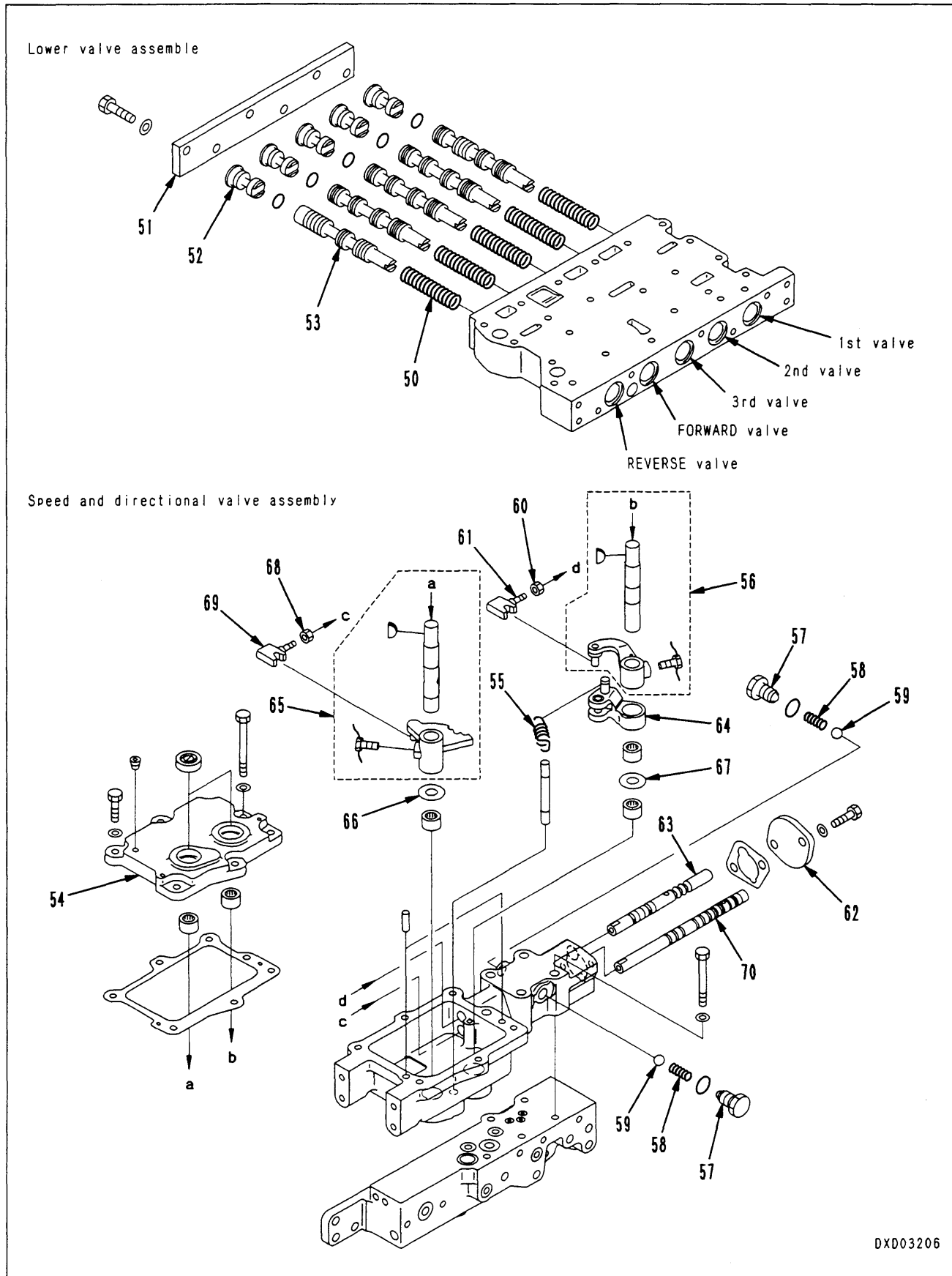

DXD03206

REMOVAL OF FINAL DRIVE ASSEMBLY

Serial No.: 10685 and up

1. Remove track shoe assembly.
For details, see REMOVAL OF TRACK SHOE ASSEMBLY.
2. Raise chassis with jack or ripper and set stand ① under frame.
3. Remove covers (1) and (2).
4. Remove cover (3), then using forcing screw, pull out drive shaft (4). ※ 1
 - ★ If the shaft will not come out, set a jack on the ground and push the shoe grouser up, then move the sprocket to the front or rear to a position where the shaft will come out, and remove the shaft.
 - ★ Pull the shaft out to a position where it contacts the sprocket.
5. Remove 3 bolts of final drive and install tool J1.
6. Sling final drive assembly (5), then remove mounting bolts, and lift off. ※ 2



Final drive assembly : **3,600 kg**

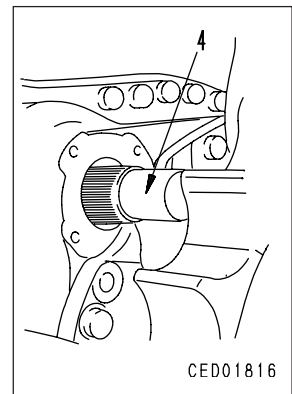
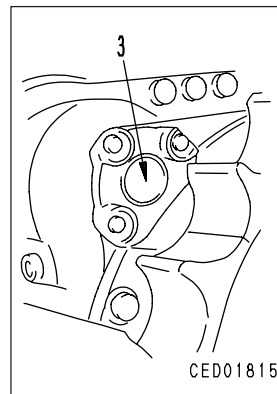
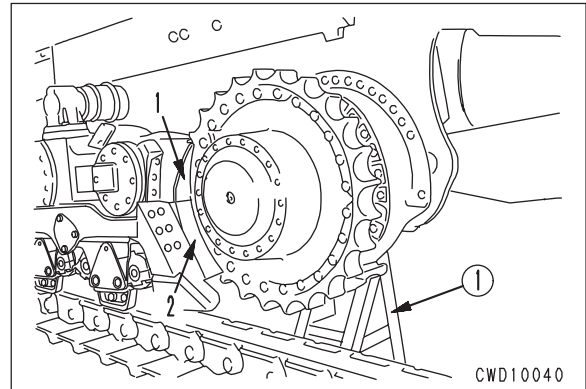

INSTALLATION OF FINAL DRIVE ASSEMBLY

Serial No.: 10685 and up

- Carry out installation in the reverse order to removal.

※ 1

- ★ If the shaft will not go in, set a jack on the ground and push the shoe grouser up, then move the sprocket to the front or rear to a position where the shaft will go in, and install the shaft.

※ 2

Final drive assembly mounting bolt :
Thread tightener (LT-2)

Final drive assembly mounting bolt :
1,960 – 2,450 Nm (200 – 250 kgm)

- **Refilling with oil (final drive case)**
Add oil through the oil filler to the specified level.



Final drive case : **71 l (GO140)**

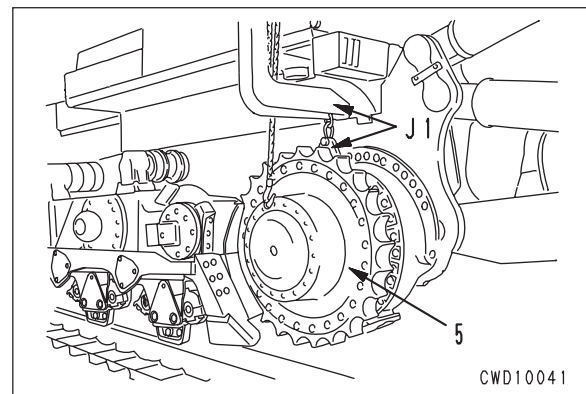

3. Sun gear

- 1) Press fit sun gear (52) to sun gear shaft, and install holder (51).

 Holder mounting bolt :

Thread tightener (LT-2)

- 2) Assemble sun gear shaft assembly (27) to carrier (53), then install holder (26) and spacer (25).

 Holder mounting bolt :

Thread tightener (LT-2)

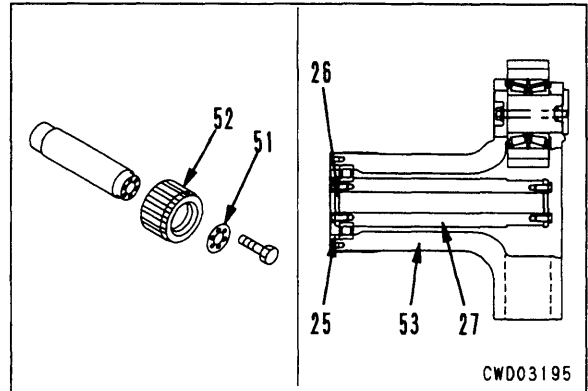

CWD03195

4. Carrier, sun gear assembly

- Using eyebolts ⑤, install carrier and sun gear assembly (20).

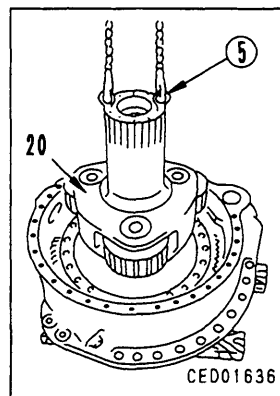

CED01636

5. Cover assembly

- 1) Assemble cover assembly as follows.

- i) Using push tools ⑪ and ⑫, install oil seals (50) and (49).

- ★ Install the bottom oil seal with the part receiving the pressure at the bottom; install the top oil seal with the part receiving the pressure at the top.

 Lip of oil seal : **Grease (G2-LI)**

 Oil seal press-fitting surface : **Gasket sealant (LG-5)**

- ★ Coat the inside surface of the case thinly with gasket sealant and wipe off any sealant that is forced out.

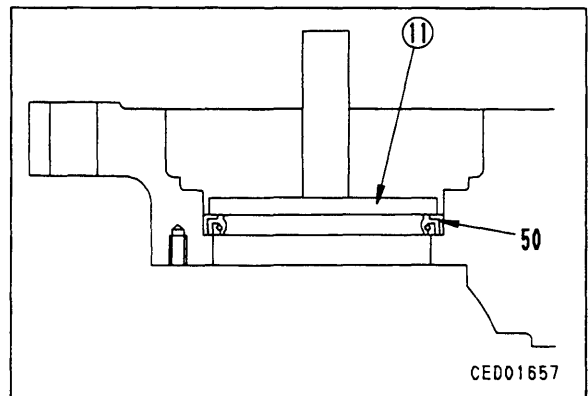

CED01657

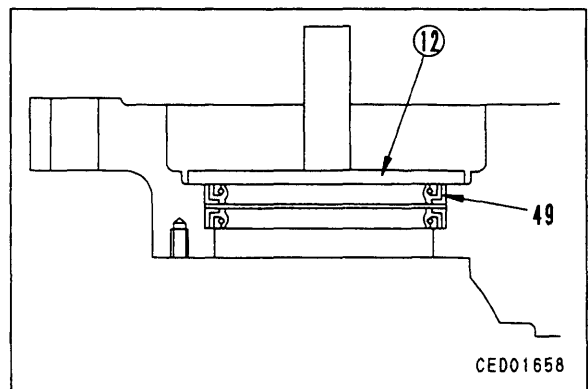

CED01658

INSTALLATION OF TRACK FRAME ASSEMBLY

Serial No.: 10601 – 10684

- Carry out installation in the reverse order to removal.

※ 1

 Inside surface of bushing:

Grease (G2-LI)

- ★ Before installing the pin, adjust the height of the track frame and align the center of the equalizer bar hole and track frame hole.
- ★ Set the pin with the grease hole facing the outside of the machine.

※ 2

- ★ Fit pin (4) and bushing (3), install cover (2), then install the cover and cushion.

※ 3

- ★ After removing the grease from the press-fitting surface of the seal, coat with gasket sealant (LG-6).
- ★ Be careful not to install with the seal displaced in the direction of twisting.

※ 4

- ★ Be careful not to install the track frame with seal (14) displaced in the direction of twisting.

- **Refilling with oil (pivot case)**
Add oil through oil filler to the specified level.



Pivot case : 26 ℓ (SAE30)

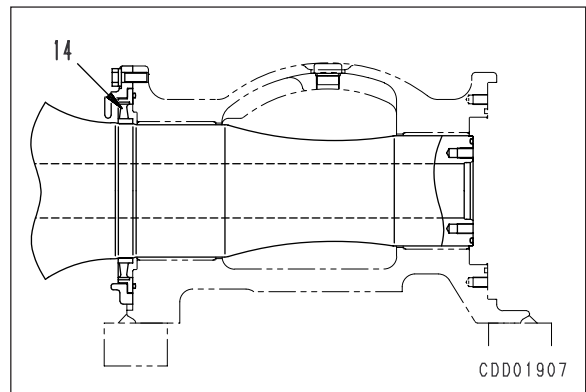

ASSEMBLY OF IDLER ASSEMBLY

Serial No.: 10685 and up

- ★ Clean all parts, and check for dirt or damage.
- 1. Set bushing (11) and tool **L1** to idler (12), and press fit bushing (11).
 - ★ First, center the bushing with a plastic hammer, then press fit with a puller.
 - ★ Press fit so that press-fitting dimension **a** from the end face of the idler to the top surface of the bushing is the dimension given below.
 - Press-fitting dimension **a** : 17 ± 0.5 mm

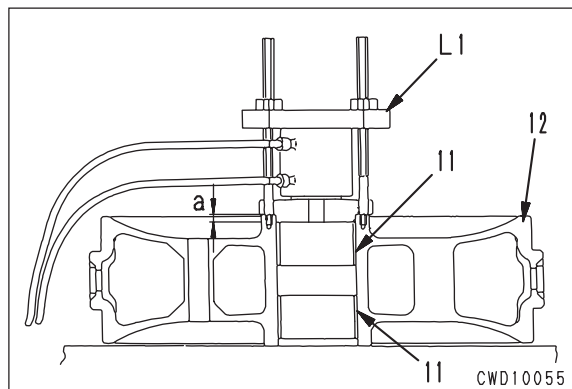

- 2. Using tool **L2**, install floating seal (10) to retainers (3) and (7).
- 3. Fit O-ring and install retainer (3) and plate (4) to idler.
 - ★ Check that the plate can be turned smoothly with the hand.

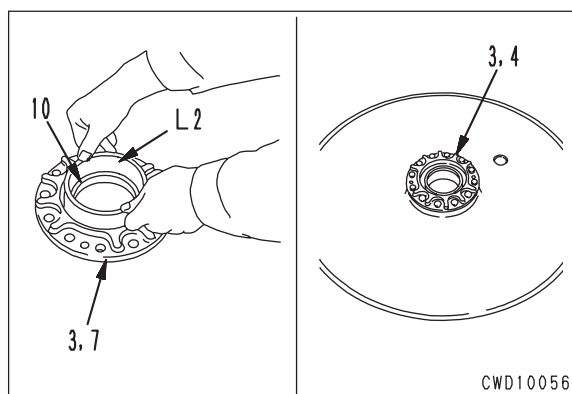

- 4. Using eyebolts ③, set idler (12) to shaft (5).
 - ★ Set block (height: approx. 200 mm) under the idler.
- 5. Turn over idler assembly.
 - ★ Tie with wire to prevent the shaft from falling out.
- 6. Fit O-ring and install retainer (7) and plate (8) to idler.

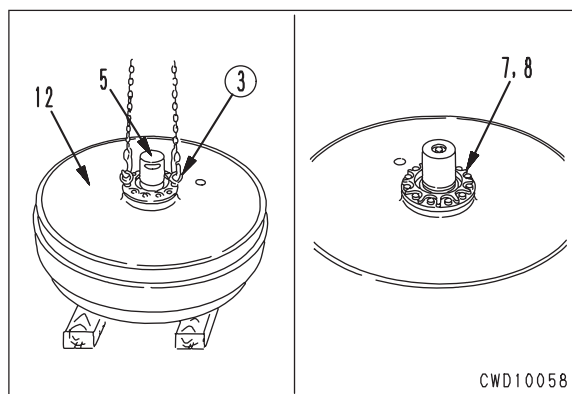

- 7. Using tool **L2**, install floating seal (9) to seal guides (2) and (6).

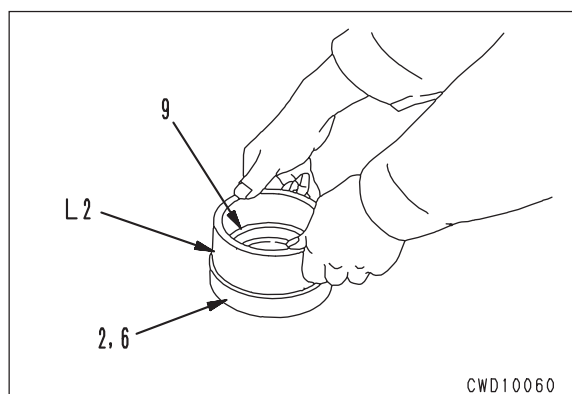

⚠ If the torque does not drop during Steps 2) and 3) described above, and the torque when the bolts are loosened remains large, there is probably damage to recoil spring set bolt (10), or nut (11) at the tip of the shaft has fallen off, so there is danger that the idler yoke assembly may fly off to the front. For this reason, disassemble as follows.

⚠ When disconnecting the idler yoke assembly and recoil cylinder assembly, do not stand in front of the idler yoke assembly or behind the recoil cylinder assembly until safety has been confirmed and the recoil spring assembly has been removed.

- i) Prepare the following parts.
 - Bolt ① (x6): 791-730-1120
 - Nut ② (x6): 01580-13326
 - Washer ③ (x6):
01643-33380 (use again)
- ii) Remove 6 bolts marked ※, then install bolts ①, nuts ②, and washers ③.
 - ★ Check that dimension **L** is less than 450 mm.
 - ★ Screw in bolts ① until they contact the bottom of the yoke thread.
- iii) Remove remaining 12 bolts (those not marked ※).
- iv) Hold bolts ① with a wrench to prevent them from turning, and loosen 2 nuts ② simultaneously on diagonally opposite sides.
 - ★ Be careful not to let the load bear on only one bolt.
- v) When recoil spring is fully extended and torque has completely dropped in loosening direction of nut ②, remove bolt ①.

★ When clearance **b** is approx. 280 mm, the spring is fully extended.

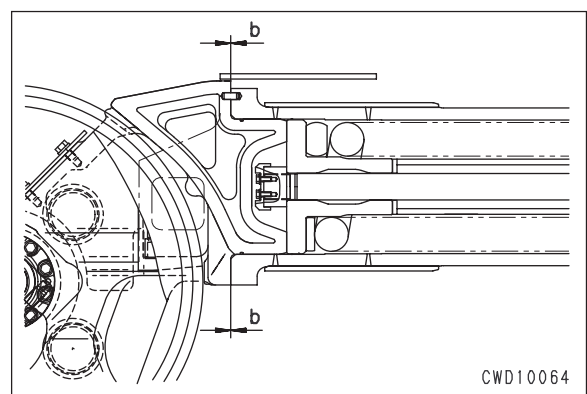
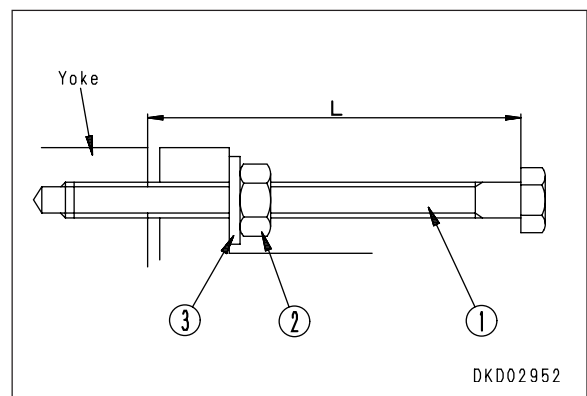
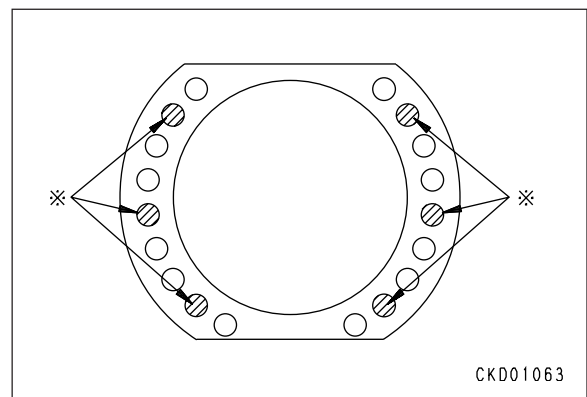
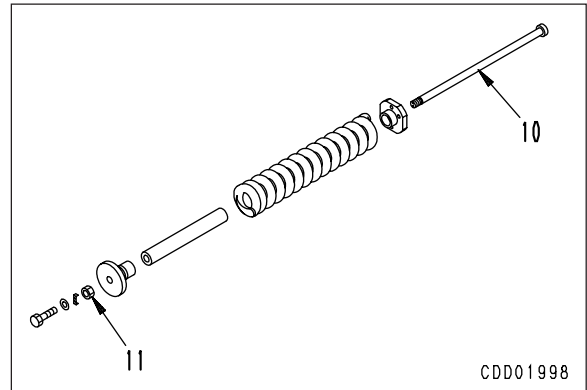

REMOVAL OF TRACK ROLLER ASSEMBLY

Serial No.: 10685 and up

1. Loosen the track shoe. For details, see EXPANDING TRACK SHOE ASSEMBLY.
2. Install tool L13 and secure bogie assembly (1). ※ 1
3. Operate the blade and ripper to lift the machine body until track roller assembly (2) separates from the track shoe.

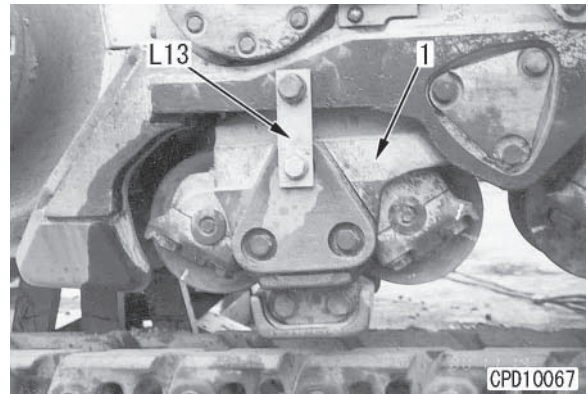

4. Place steel plate ① on the track shoe and operate the blade and ripper to lower the machine body until the track roller assembly comes in contact with the steel plate.
 - ★ Operate the blade and ripper slowly, running the engine at the low idling speed.

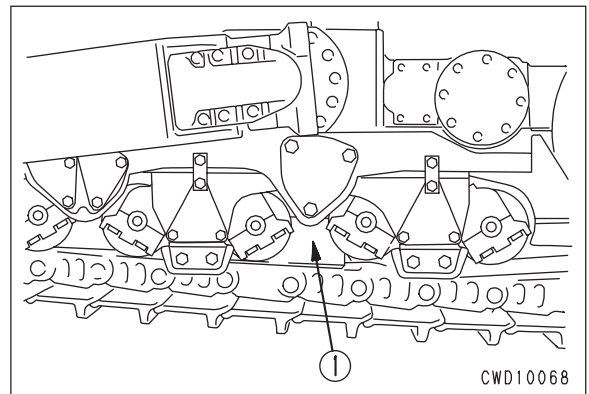

5. Remove the mounting bolts and place track roller assembly (2) on steel plate ①. ※ 2
6. Operate the blade and ripper to lift the machine body until track roller assembly (2) separates from the bogie.

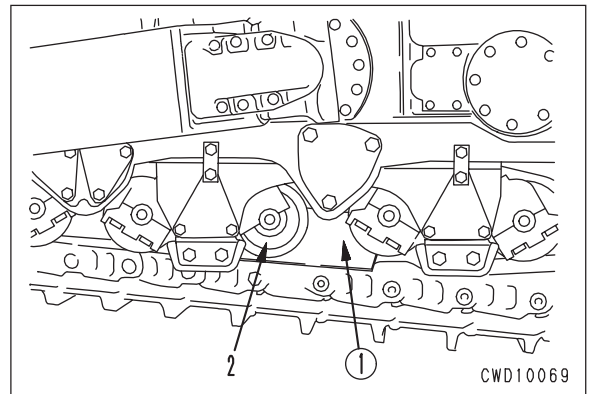

7. Pull track roller assembly (2) out of the machine body from the top of the steel plate with a bar, etc. ※ 3



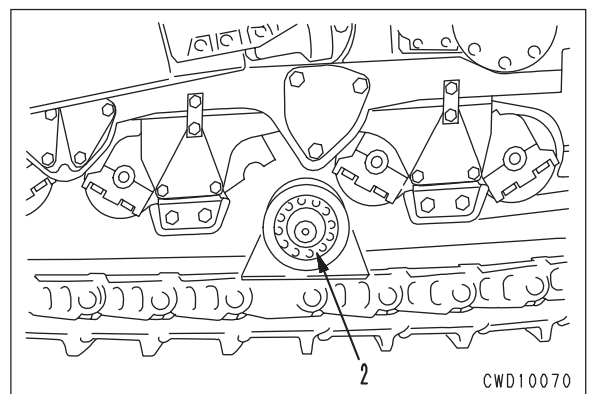

Track roller assembly: **240 kg**

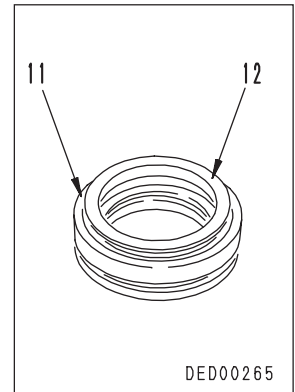
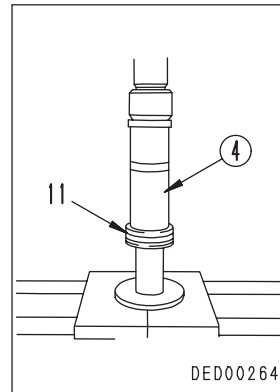

10. Remove seal guide (11) with push tool (4).

11. Remove floating seal (12) from seal guide (11).



6. Press fit the pin assembly on the opposite side of the bogie according to above steps 3 and 4.
7. Tighten the mounting bolts of pin assembly cover (2) (2 places on inside and outside).
 **kgm** Cover mounting bolt:
883 – 1,470 Nm {90 – 150 kgm}

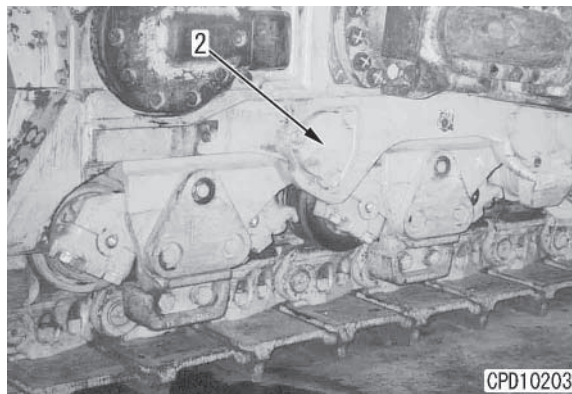

8. Adjust the tension of the track shoe. For detail, see TESTING AND ADJUSTING, Testing and adjusting track shoe tension.

DISASSEMBLY OF BOGIE ASSEMBLY

Serial No.: 10685 and up

1. Track roller assembly

Turn over bogie assembly (1) and lift off 2 track roller assemblies (2).

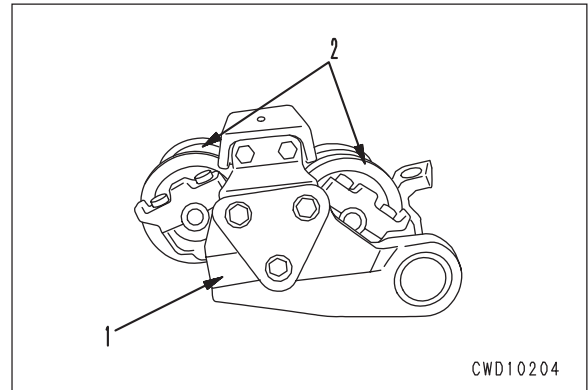

2. Remove cover (3).

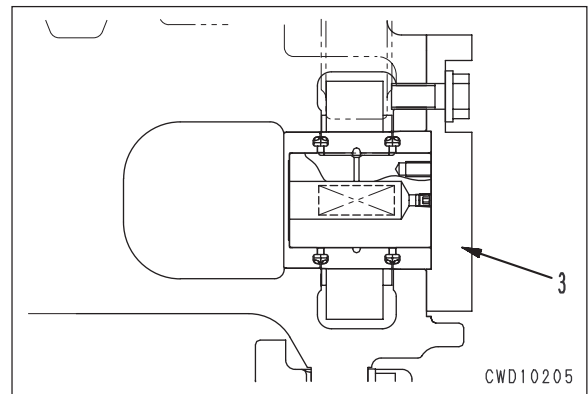

3. Disassemble the pin assembly according to REMOVAL OF BOGIE ASSEMBLY (Step 8).

4. Disconnection of bogie

Disconnect inner bogie (4) and outer bogie (5).

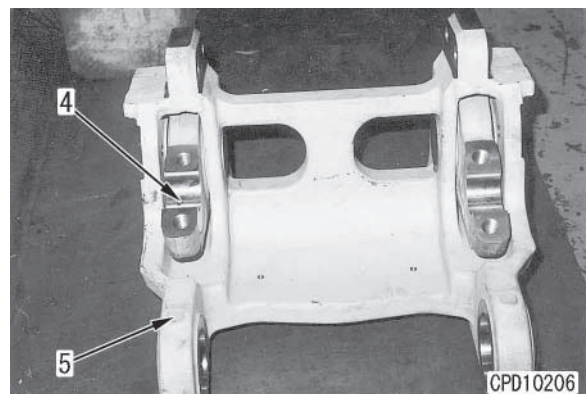

- 3) Remove floating seals (9) from the end faces of rings (8) and (12).
 ★ Store the floating seals so that they will not be damaged.

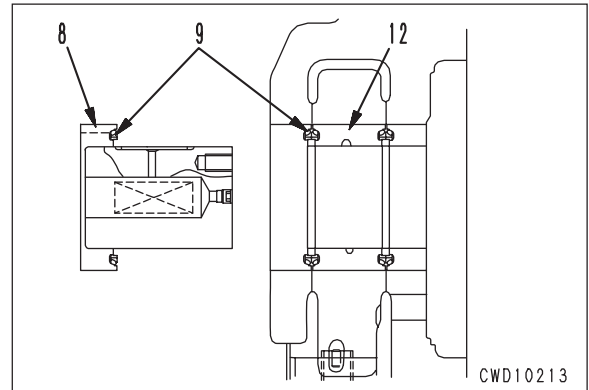

- 4) Set tool L15.

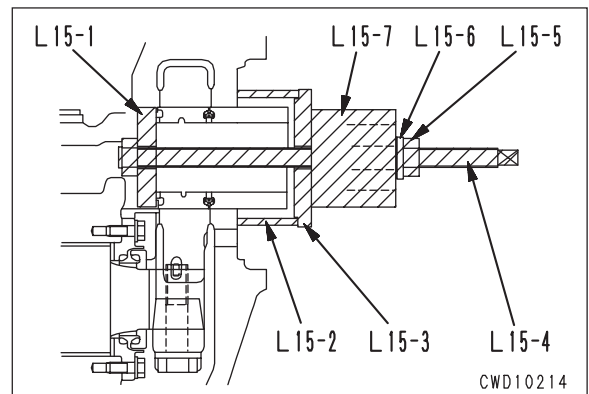

- 5) Pull out spacer (11) and rings (12) and (13).
 ★ Pulling out force:
 225.5 – 460.9 kN {23 – 47 tons}

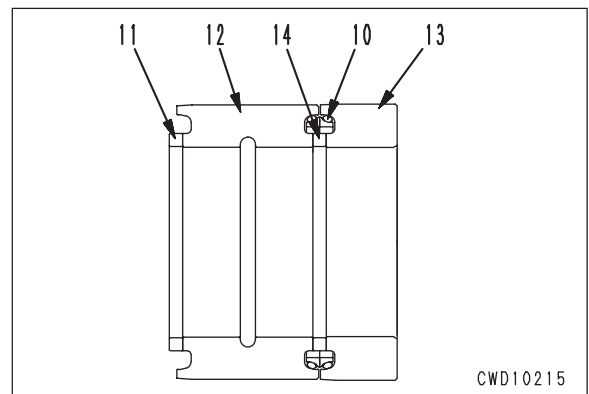

- 6) Remove spacer (11).
 7) Remove spacer (14) and floating seals (10) between rings (12) and (13).
 ★ Store the floating seals so that they will not be damaged.

10. Lower bogie (5) on the steel plate and pull it out.



Bogie assembly : **180 kg**

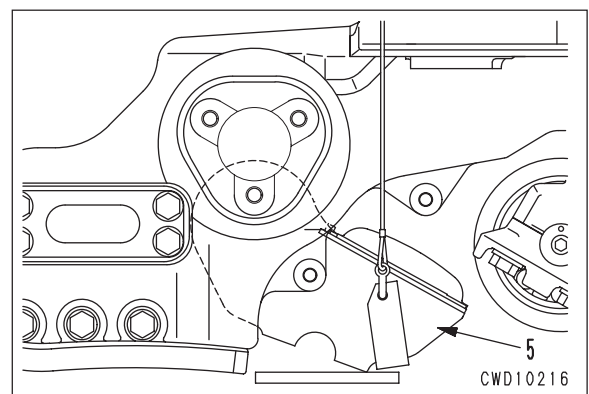

OVERALL DISASSEMBLY OF TRACK SHOE

Serial No.: 10685 and up

- ★ When disassembling the track shoe, see shop manual – GUIDANCE FOR REUSABLE PARTS – LUBRICATED TRACKS (III) (Form No.: SEBG4092).

1. Removal of shoe

Sling the shoe assembly and set it on a floor with the shoe up. Remove the shoe with a shoe bolt impact wrench.

- ★ If a shoe bolt is still hard (If its torque is not lowered to 0) after it is unscrewed by 1 turn, loosen the other bolts, and it can be removed easily.
- ★ If a bolt is unscrewed forcibly while its torque is not 0, it will stick to the link and will need to be repaired.
- ★ When moving the shoe assembly, take care not to damage the master link.
- ★ If it is obliged to cut a shoe nut with gas, keep the temperature of the sealing parts below 80°C and prevent the spatters from entering the clearance of the link so that the sealing parts will not be deteriorated by the heat.

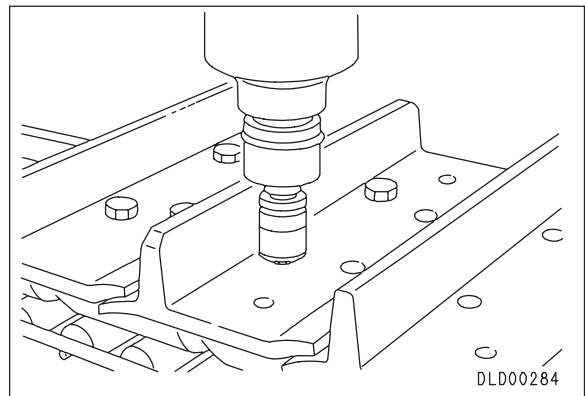

14) Measure the distance between the shoe bolt holes with a shoe bolt hole pitch gauge and check that the result is within the limits.

★ If the distance between the shoe bolt holes is longer than the limit, disassemble and check for abnormality, then press fit again.

★ If the distance between the shoe bolt holes is shorter than the limit and the shoe cannot be installed, the spacer or bushing end may be worn more than the allowable limit. In this case, disassemble and replace the parts.

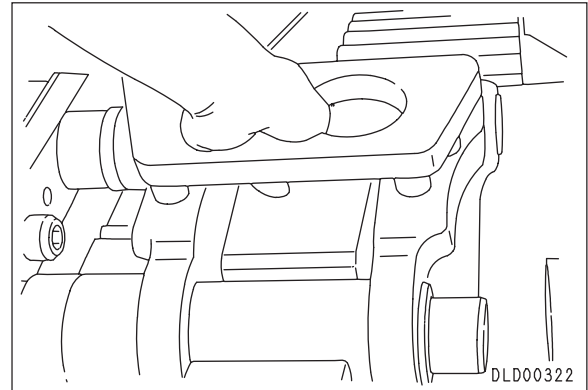

15) Install the ring to jig **R12**.

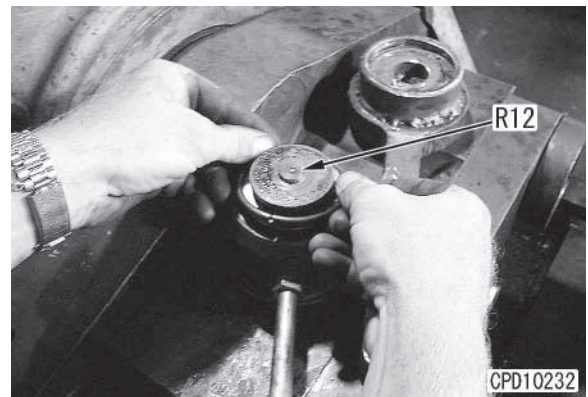

16) Match the jig to the pin hole and push it in until the ring is inserted in the pin hole.

★ A sound is made when the ring is inserted in the pin hole.

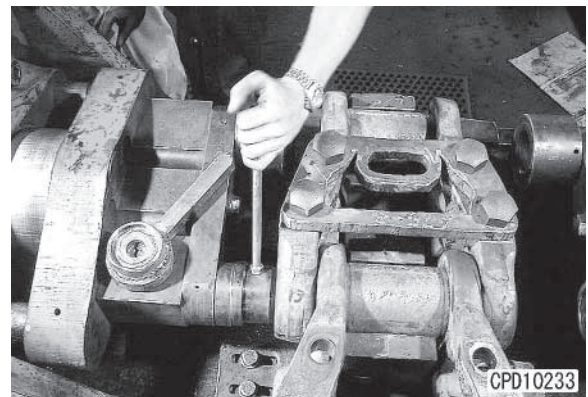

17) Similarly, insert the ring in the pin groove on the opposite side with jig **R9**.

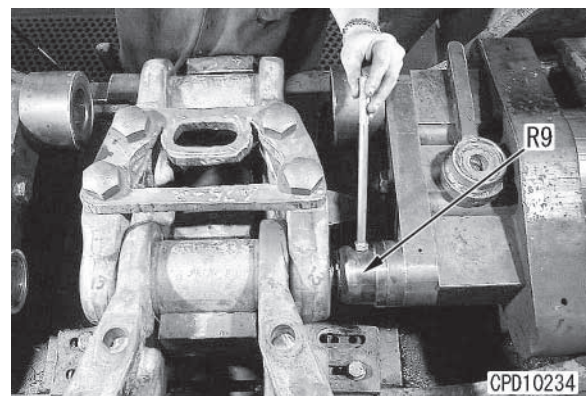

FIELD DISASSEMBLY OF ONE LINK

Serial No.: 10685 and up

1. Install tools **R8-4**, **R8-1**, and **R8-5** to link (1) with 2 bolts (2).
★ Use 2 track bolts as 2 bolts (2).

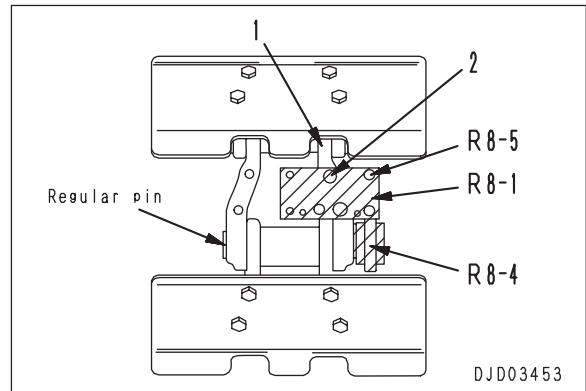

2. Install tool **R8-12** to tool **R8-4**.
★ Check that the hole of **R8-12** is aligned. If it is not aligned, retighten **R8-5** and adjust the position of **R8-12**.
Install tool **R8-10** to tool **R8-8**. Install a rope to **R8-10**, then sling and install **R8-10** to **R8-12**.
Install tools **R8-2** and **R8-3** to tool **R8-1**.
★ Hitch and install **R8-2** to the rib of **R8-8** so that **R8-8** will not lean.

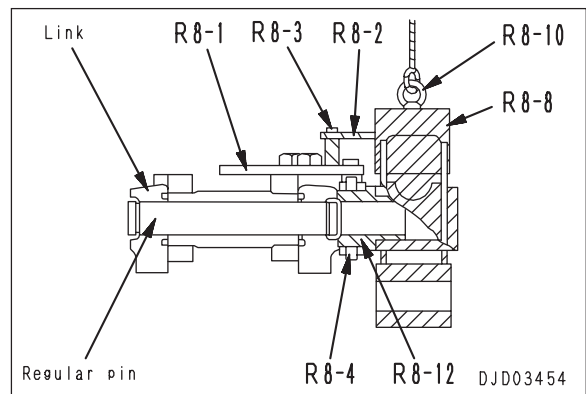

3. Install tools **R8-6**, **R8-10**, **R8-7**, and **R8-11** to tool **R8-28**.
Install ropes to the eyebolt of **R8-28** and **R8-10**, then sling them so that **R8-7** will be horizontal.
4. Insert **R8-7** in the hole of **R8-8** installed to the track, then clamp it with **R8-9**.

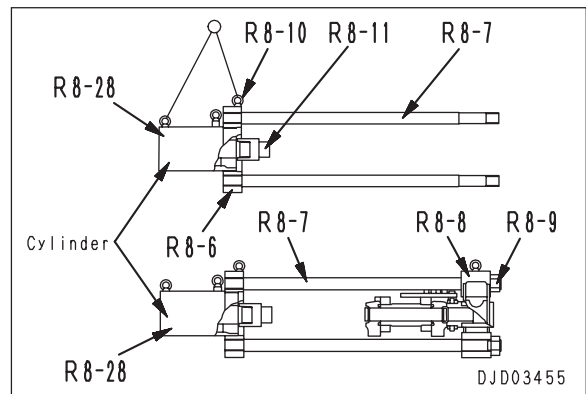

3. Assembly of link on pin side

- 1) Set spacer (3) and seal assembly (4) to the counterbore of the master link.

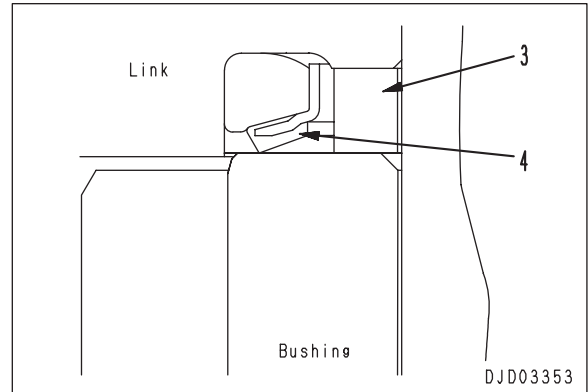

- 2) Pass pin (10) through bushing (9) and set and press fit pin-side master links (11) from both sides with tool **R8**.
- 3) Install the ring with tools **R8, R9, R11, R12, and R13**.
- 4) Drive large plug (13) with tool **R3** and supply oil with tool **R5**, then drive small plug (14) with tool **R4**.

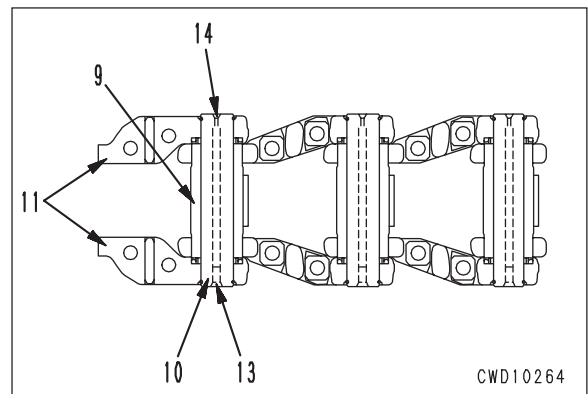

4. Connection of master links

Place the assembled 2 shoes on a level place in 1 line with the shoe side up. Pull pin-side master link (15) and bushing-side master link (16) together and set them to each other by the mating faces. Place the shoe on the links and check that the shoe bolt can be tightened easily until the mating faces of the links are fitted together, then connect the links with the master bolts.

 Shoe bolt:

Lubricant containing molybdenum disulfide (LM-P)

 Shoe bolt (Master link)

Initial torque:

980 ± 98 Nm {100 ± 10 kgm}

Retightening angle: **180 ± 10°**

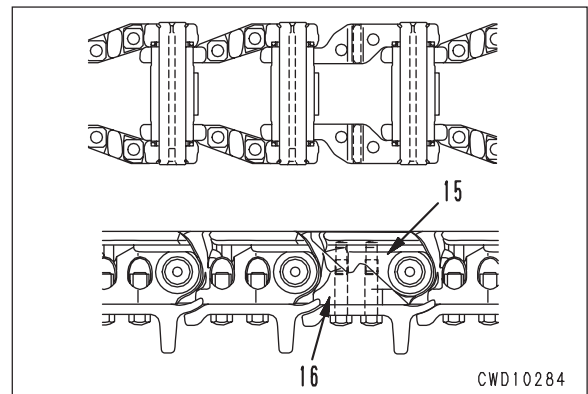

REMOVAL OF HYDRAULIC PUMP ASSEMBLY

⚠ Lower the work equipment to the ground and stop the engine. Release the remaining pressure in the hydraulic piping.
For details, see TESTING AND ADJUSTING, Releasing remaining pressure from hydraulic circuit.

Then loosen the oil filler cap slowly to release the pressure inside the hydraulic tank.

⚠ Disconnect the cable from the negative (-) terminal of the battery.

1. Drain oil from hydraulic tank.



Hydraulic tank : 340 ℓ

2. Remove floor frame assembly.
For details, see REMOVAL OF FLOOR FRAME ASSEMBLY.
3. Disconnect hydraulic oil temperature sensor connector (CN452)(1).
4. Disconnect hoses (2), (3), (4), (5), (6), and (7).
5. Disconnect suction tubes (8) and (9). ※ 1
6. Sling hydraulic assembly (10), then remove mounting bolts, and remove.



Hydraulic pump assembly : 80 kg

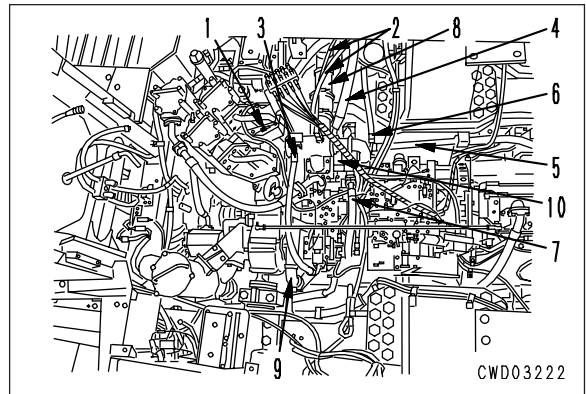

INSTALLATION OF HYDRAULIC PUMP ASSEMBLY

- Carry out installation in the reverse order to removal.

※ 1

 Coupling clamp bolt of tube (8):
27.1 – 29.4 Nm {2.76 – 3.0 kgm}

 Coupling clamp bolt of tube (9):
14.7 – 18.6 Nm {1.5 – 1.9 kgm}

- **Refilling with oil (hydraulic tank)**
Add oil through the oil filler to the specified level, and run the engine to circulate the oil through the system. Then check the oil level again.

REMOVAL OF PPC RELIEF VALVE ASSEMBLY

- ⚠** Lower the work equipment to the ground and stop the engine. Release the remaining pressure in the hydraulic piping.
For details, see TESTING AND ADJUSTING, Releasing remaining pressure from hydraulic circuit.
Then loosen the oil filler cap slowly to release the pressure inside the hydraulic tank.

1. Remove operator's cab right cover.
2. Remove hoses (1), (2), (3), and (4).
3. Remove PPC relief valve assembly (5).

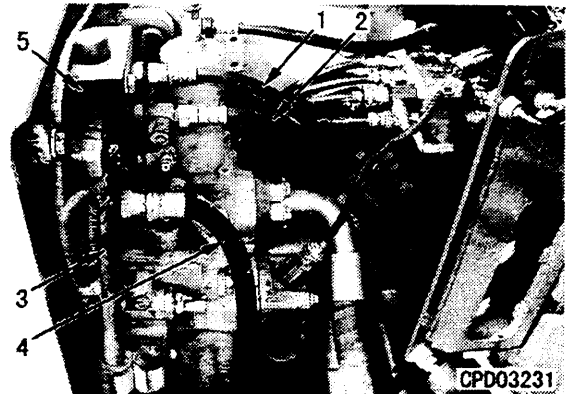

INSTALLATION OF PPC RELIEF VALVE ASSEMBLY

- Carry out installation in the reverse order to removal.

REMOVAL OF BLADE ASSEMBLY

⚠ Lower the work equipment to the ground in a horizontal place, and set blocks ① securely under the left and right straight frames.

1. Remove cap (1) of lift cylinder. ※ 1
★ Check the number and thickness of shims (2), and keep in a safe place.
2. Sling lift cylinder assembly (3), then start engine and retract piston rod fully, fit cylinder lock tool and secure to radiator guard.
★ Tie the piston rod with wire to prevent it from coming out.
• Repeat the same procedure to disconnect the cylinder from the blade on the opposite side.

⚠ Release the remaining pressure from the hydraulic circuit.
For details, see TESTING AND ADJUSTING, Releasing remaining pressure from hydraulic circuit.
Then loosen the oil filler cap slowly to release the pressure inside the hydraulic tank.

3. Remove left and right covers (4).
4. Disconnect hoses (5).
★ Mark the hoses before disconnecting.
★ Fit blind plugs to prevent dirt or dust from entering the piping.
5. Remove left and right trunnion caps (6).

6. Remove blade assembly (7).
★ Start the engine, drive the machine slowly in reverse, and disconnect the blade assembly from the trunnions.

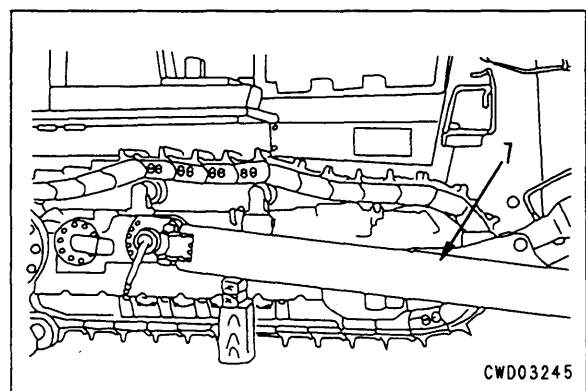
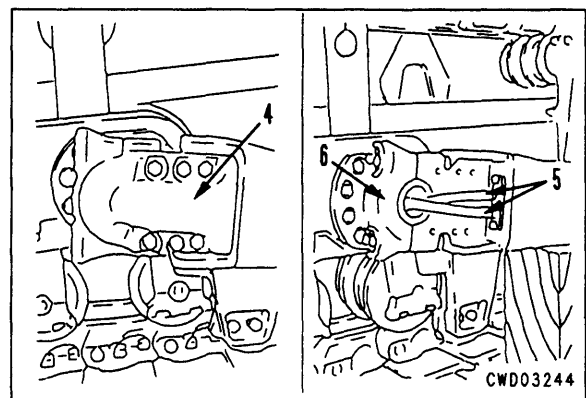
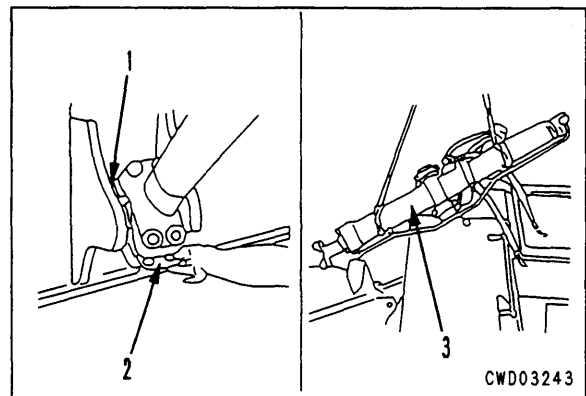
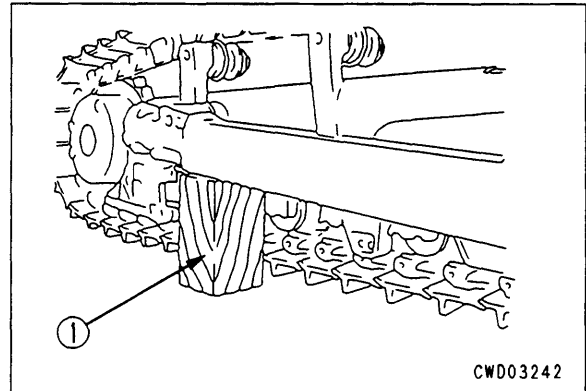

- 8. Disconnect blade PPC hose (10) and hose clamp (11).
- 9. Disconnect blade PPC hoses (12), (13), and (14).
 - Single tilt specification machine only. ※ 2

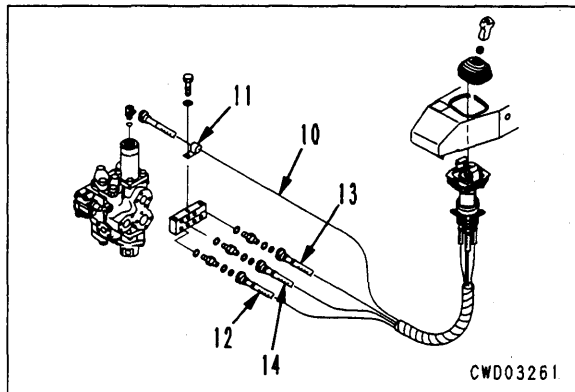

- 10. Disconnect ripper PPC hoses (15), (16), (17), and (18). ※ 3

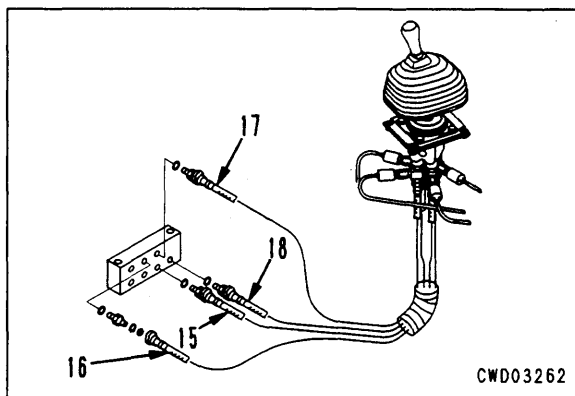

- 11. Disconnect accumulator hose (19).
- 12. Disconnect tank return hoses (20) and (21).

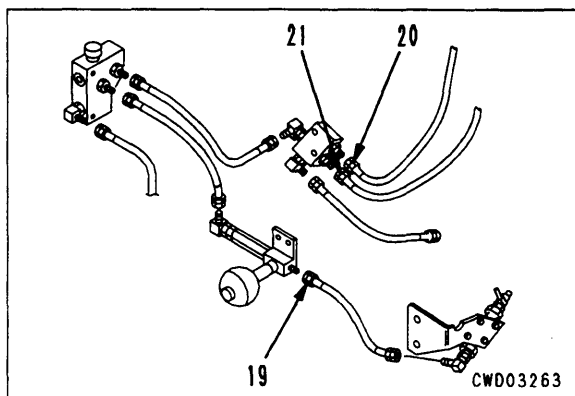

- 13. Disconnect clamps (22) (2 places) for wiring harness and washer tank hose.
- 14. Disconnect ground wiring (23) (SX-8).
- 15. Disconnect wiring connectors (24) (CN-122), (25) (CN-421), (26) (CN-599), (27) (CN-506), (28) (CN-577), (29) (CN-992), and (30) (CN-993).

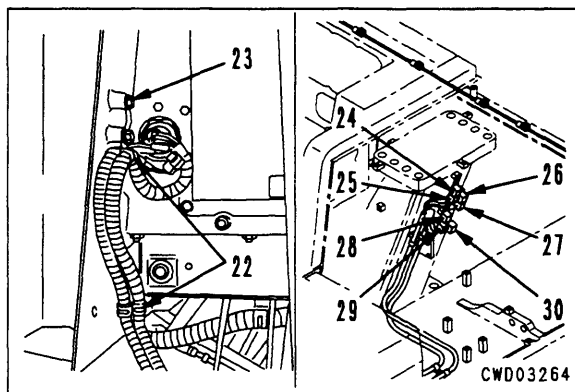

REMOVAL OF AIR CONDITIONER UNIT ASSEMBLY

1. Remove left and right covers (1) and cover (2).

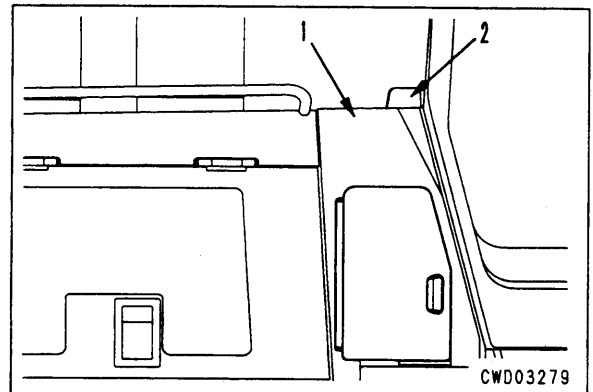

2. Disconnect 2 air conditioner hoses (3). ※ 1
- ★ Loosen the sleeve nut slightly and release the air conditioner gas (R134a) completely before disconnecting the hoses.
 - ★ Disconnect at the air conditioner end, then move the hoses towards the engine.
 - ★ Fit blind plugs to prevent dirt or moisture from entering the hoses.
 - ★ Be careful not to damage or drop the O-rings.
3. Disconnect 2 heater hoses (4).
- ★ Close the heater valve at the engine end.
4. Disconnect wiring connectors (5) (CN-S13), (6) (CN-214), (7) (CN-216), and (8) (CN-215), and ground connection (CN-206).

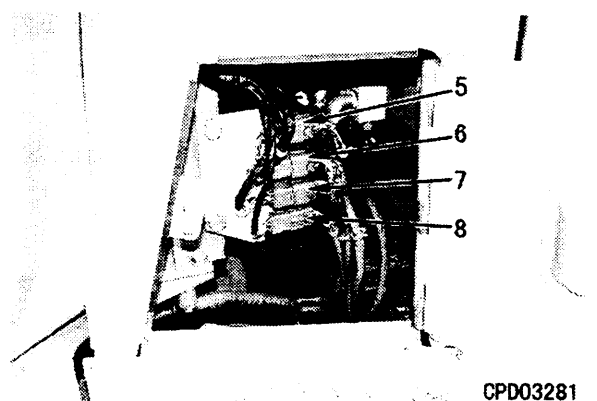
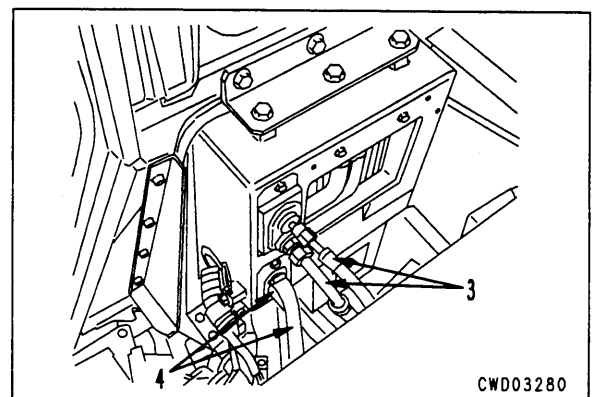

5. Remove covers (12) and (13).

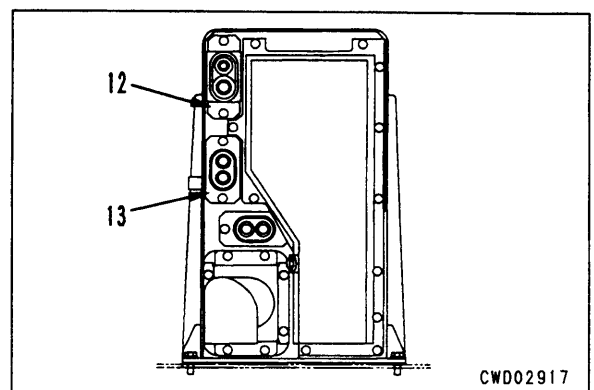

TORQUE CONVERTER VALVE

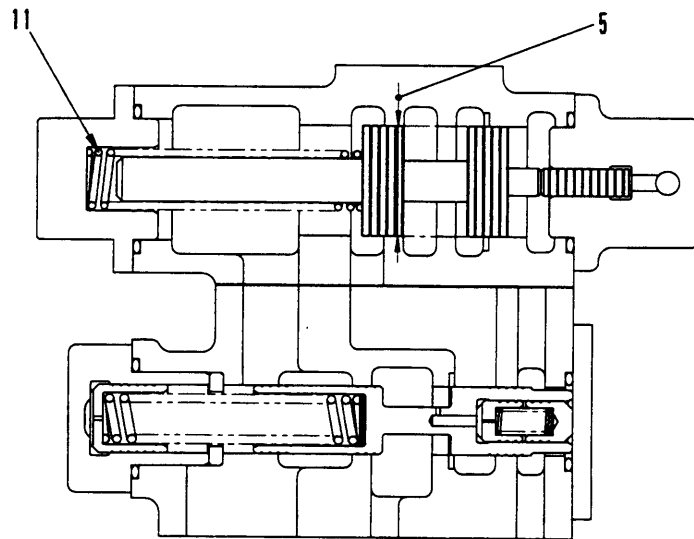
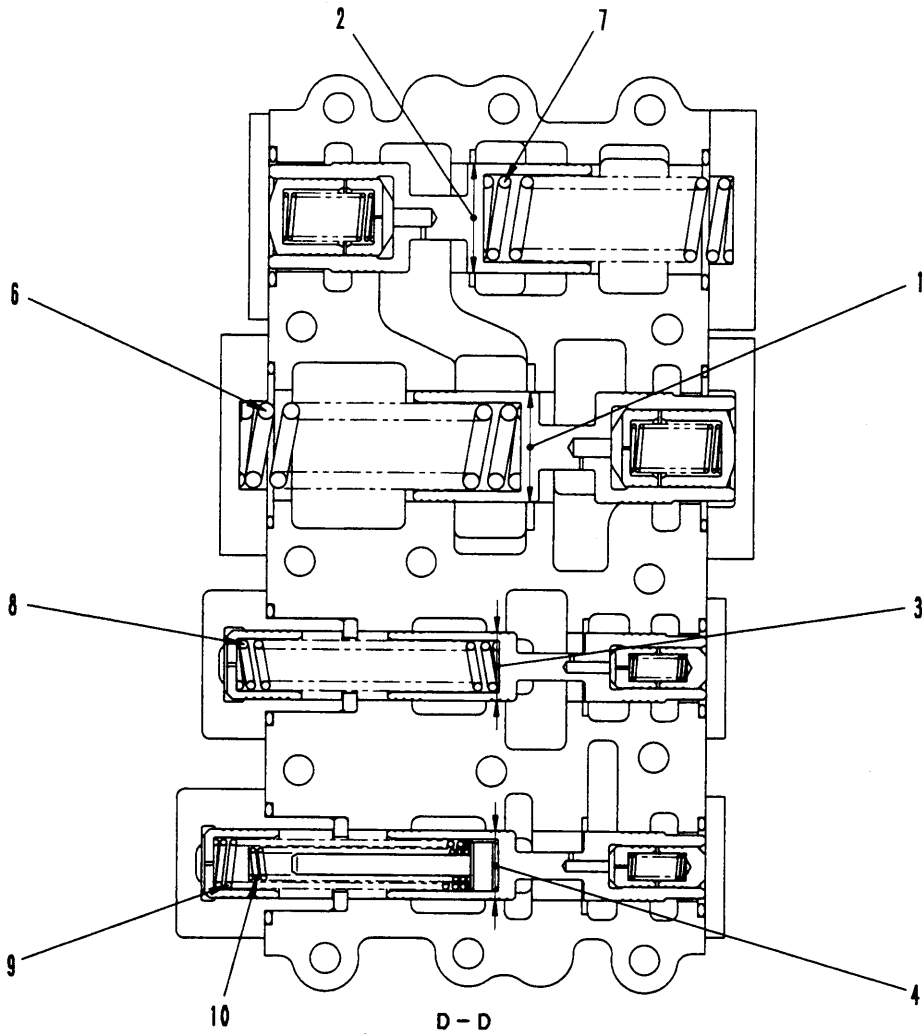

SAD01225

Unit: mm

No.	Check item	Criteria				Remedy
1	Thickness of brake, clutch plate	Standard size		Repair limit		Replace
		4.2		3.9		
1	Warping of brake, clutch plate	Tolerance		Repair limit		Correct or replace
		less than 0.3		0.4		
2	Thickness of brake, clutch disc	Standard size		Repair limit		Replace
		5.4		5.1		
2	Warping of brake, clutch disc	Tolerance		Repair limit		Correct or replace
		less than 0.3		0.4		
3	Thickness of total brake plate and disc assembly	Standard size		Repair limit		Replace
		82.2		78.5		
4	Thickness of total brake plate and disc assembly	76.8		74.1		
5	Backlash of brake, clutch disc, and brake hub	Standard clearance		Repair limit		
		0.4 - 0.7		1.0		
6	Backlash between bevel gear and pinion	0.3 - 0.4		0.75		Adjust or replace
7	Clearance between seal ring and piston seal ring groove	0.5 - 0.8		0.8		
8	Clearance between seal ring and cage seal ring groove	0.5 - 0.8		0.8		
9	Inside diameter of seal ring contact surface of cage	Standard size	Tolerance		Standard clearance	Clearance limit
			Shaft	Hole		
10	Inside diameter of seal ring contact surface of piston	350	-0.5	+0.089	0.5 - 0.789	
			-0.7	0		
11	Brake belleville spring	300	-0.110	+0.052	0.110 - 0.243	Replace
			-0.191	0		
11	Clutch belleville spring	Standard size			Repair limit	
		Free length	Installation length	Installation load	Free length	Installation load
		19.7	12.9	46.97 kN {4,790 kg}	19.1	44.62 kN {4,550 kg}
12	Clutch belleville spring	20.4	12.9	55.7 kN {5,680 kg}	20.0	53.35 kN {5,440 kg}
13	Interference between bevel gear and reamer bolt	Standard size	Tolerance		Standard interference	Interference limit
			Shaft	Hole		
13	Interference between bevel gear and reamer bolt	20	+0.023	+0.033	-0.032 - 0.019	0.02
			+0.002	0		
14	Runout of rear face of bevel gear	Service limit: 0.05 (measure after installing to bevel gear shaft)				Correct or replace
15	Preload of bevel gear shaft taper roller bearing	Standard rotating torque: 9.8 - 11.8 Nm {1.0 - 1.2 kgm} (When bevel pinion and gear are not meshed, at tip of bevel gear: 51.0 - 61.8 N {5.2 - 6.3 kg})				Adjust
16	Standard shim thickness of bearing cage	2.0				Adjust shim

Serial No.: 10685 and up

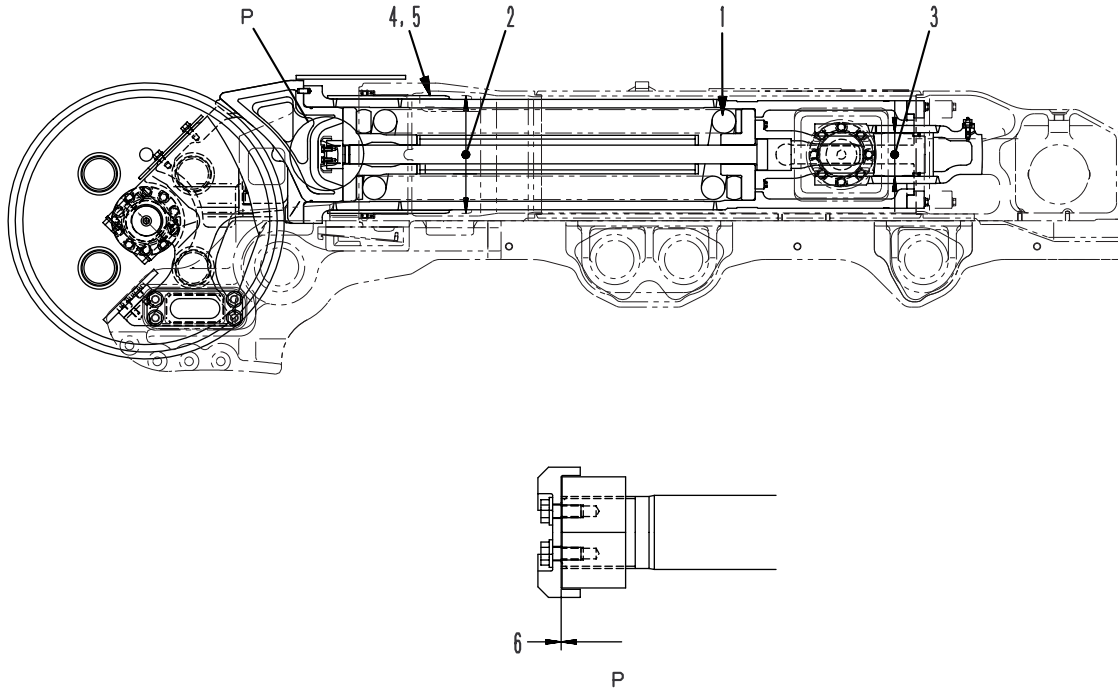

SVD04112

Unit: mm

No.	Check item	Criteria				Remedy
		Standard size		Repair limit		
1	Recoil spring	Free length	Installation length	Installation load	Free length	Installation load
		1,731	1,455	788.3 N {80,435 kg}	1,705	715.4 N {73,000 kg}
2	Clearance between inner cylinder and outer cylinder of outer cylinder bushing	Standard size	Tolerance		Standard clearance	Clearance limit
			Shaft	Hole		
		445	-0.068 -0.165	+0.323 +0.060	0.128 – 0.488	0.8
3	Clearance between adjustment cylinder and bushing	165	-0.100 -0.550	+0.063 0	0.100 – 0.613	—
4	Press-fitting force for outer cylinder bushing (outer cylinder side)	51.0 – 99 kN {5.2 – 10.1 ton}				Adjust
5	Press-fitting force for outer cylinder bushing (inner cylinder side)	129.4 – 389.1 kN {13.2 – 39.7 ton}				
6	Clearance between recoil spring mount nut and lock plate	0 – 1.0				

Unit: mm

No.	Check item	Criteria				Remedy	
		Standard size		Repair limit			
1	Outside diameter of flange (outside)	344		—		Rebuild or replace	
2	Outside diameter of flange (inside)	332		—			
3	Outside diameter of tread (Single flange)	300		230			
	(Double flange)	300		246			
4	Thickness of tread (Single flange)	71.5		36.5			
	(Double flange)	7.15		44.5			
5	Overall width	423		—			
6	Width of tread (single flange)	99.5		—			
7	Width of tread (double flange)	99.5		—			
8	Width of flange (Outside of double flange)	34.5		19.5			
9	Width of flange (Inside of double flange)	27.5		12.5			
10	Width of shaft flange	379		—			
11	Clearance between shaft and bushing	Standard size	Tolerance		Standard clearance	Clearance limit	Replace bushing
		147	Shaft	Hole			
12	Interference between shaft and ring	Standard size	Tolerance		Standard interference	Interference limit	Replace
		84	Shaft	Hole			
13	End play	0.44 – 0.91		—		Adjust or replace	

※1: For Serial No.: 10684 and up

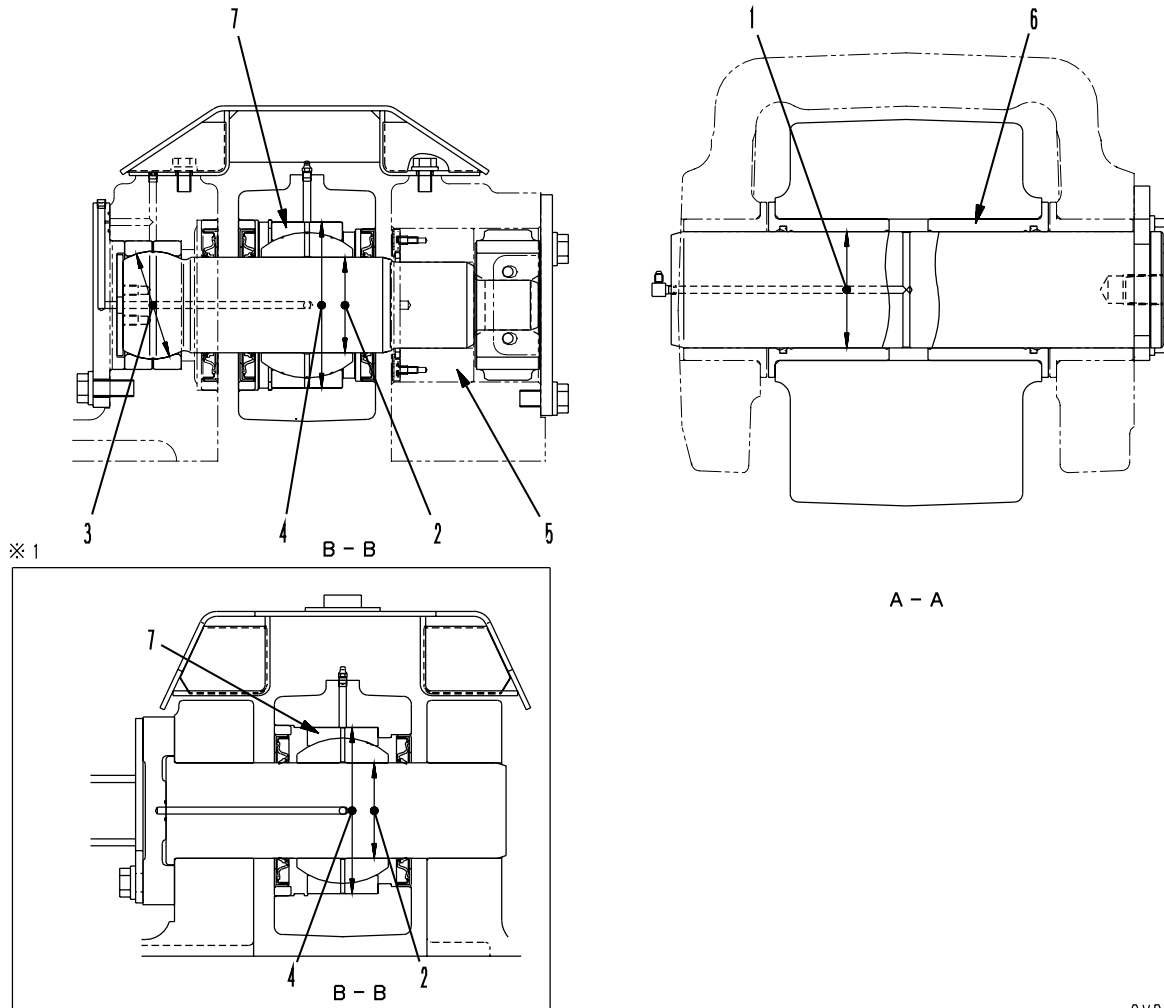

SVD04117
Unit: mm

No.	Check item	Criteria				Remedy
		Standard size	Tolerance		Standard clearance	
1	Clearance between center pin and bushing	140	-0.043 -0.083	+0.225 +0.143	0.186 – 0.308	1.0
2	Clearance between side pin and bushing	115	-0.048 -0.078	+0.015 -0.015	0.033 – 0.093	1.0
3	Clearance between side pin and spherical surface of bushing	130	-0.1 -0.3	+0.3 +0.1	0.2 – 0.6	1.0
4	Interference between side pin boss and bushing	Standard size	Tolerance		Standard interference	Interference limit
		200	+0.051 +0.031	-0.033 -0.079		
5	Press-fitting force for side pin bushing	121.5 – 294 kN {12.4 – 30 ton}				—
6	Press-fitting force for center pin bushing	68.6 – 232.2 kN {7 – 23.8 ton}				
7	Press-fitting force for side pin bushing	47.0 – 96.0 kN {4.8 – 9.8 ton}				

Unit: mm

No.	Check item	Criteria					Remedy
		Standard size			Repair limit		
		Free length x O.D.	Installation length	Installation load	Free length	Installation load	
1	Centering spring (for P1)	37.9 x 15.6	32.5	156 N {15.9 kg}	—	124.5 N {12.7 kg}	Replace spring if damaged or deformed
2	Metering spring	26.53 x 8.15	24.9	16.7 N {1.7 kg}	—	13.7 N {1.4 kg}	
3	Centering spring (for P2)	48.6 x 15.5	32.5	108 N {11.0 kg}	—	86.2 N {8.8 kg}	
4	Centering spring (for P3, P4)	48.6 x 15.5	32.5	108 N {11.0 kg}	—	86.2 N {8.8 kg}	
5	Detent spring (for P1)	20.39 x 19.5	12.7	168 N {17.1 kg}	—	134 N {13.7 kg}	
6	Detent spring (for P2)	45.36 x 7.5	26	38.44 N {3.92 kg}	—	30.79 N {3.14 kg}	

Unit: mm

No.	Check item	Criteria				Remedy
		Standard size	Tolerance		Standard clearance	
	Shaft		Hole			
1	Clearance between bushing and bracket and arm mount pin	140	-0.043 -0.106	+0.193 +0.050	0.093 - 0.299	1.5
2	Clearance between bushing and beam and arm mount pin	140	-0.043 -0.106	+0.500 +0.300	0.343 - 0.606	1.5
3	Clearance between cylinder mount pin and bushing	110	-0.036 -0.090	+0.289 +0.123	0.159 - 0.379	1.5
4	Clearance between shank and mount pin	Standard size	Tolerance		Repair limit	
		100	±0.3			
5	Wear of point	Standard size		Repair limit		
		460		300		
6	Wear of protector	224		184		

Replace

CLICK HERE TO **DOWNLOAD** THE COMPLETE MANUAL

- Thank you very much for reading the preview of the manual.
- You can download the complete manual from: www.heydownloads.com by clicking the link below



- Please note: If there is no response to CLICKING the link, please download this PDF first and then click on it.

CLICK HERE TO **DOWNLOAD** THE COMPLETE MANUAL