

Service Manual

JS200LC
JS240LC
JS300LC
JS450LC

PUBLISHED BY THE
TECHNICAL PUBLICATIONS DEPARTMENT
OF JCB SERVICE; ©
ROCESTER, STAFFORDSHIRE, ST14 5LS,
ENGLAND

Tel. ROCESTER (0889) 590312
PRINTED IN ENGLAND

Publication No. 9803/6200

General Information	1
Care & Safety	2
Routine Maintenance	3
Optional Equipment	A
Body & Framework	B
Electrics	C
Hydraulics	E
Transmission	F
Brakes	G
Track & Running Gear	J
Engine	K

CLICK HERE TO **DOWNLOAD** THE COMPLETE MANUAL

- Thank you very much for reading the preview of the manual.
- You can download the complete manual from: www.heydownloads.com by clicking the link below



- Please note: If there is no response to CLICKING the link, please download this PDF first and then click on it.

CLICK HERE TO **DOWNLOAD** THE COMPLETE MANUAL

Service Tools (continued)

SECTION E - HYDRAULICS

Hydraulic Tank - JS 200LC and 300LC

	JS200LC	JS300LC
A	Dia. 40mm (1.57in)	
B	Dia. 26mm (1.02in)	
C	40mm (1.57in)	
D	50mm (1.97in)	
E	Dia. 10mm (0.39in)	
F	600mm (23.6in)	650mm (25.6in)
G	9mm (0.35in)	
H	24mm (0.94in)	30mm (1.18in)
I	Dia. 95mm $^{+0}_{-0.1}$ (3.74in $^{+0}_{-0.004}$)	
J	Dia. 90mm $^{+0}_{-0.1}$ (3.54in $^{+0}_{-0.004}$)	
K	110 mm (4.33 in)	
L	4.1mm (0.16in)	
M	Radius 0.7mm (0.028in)	
N	130mm (5.12in)	
O	4.0mm (0.16in)	-
P	3.0mm (0.118in)	-
Q	15°	-
O-ring	G90	

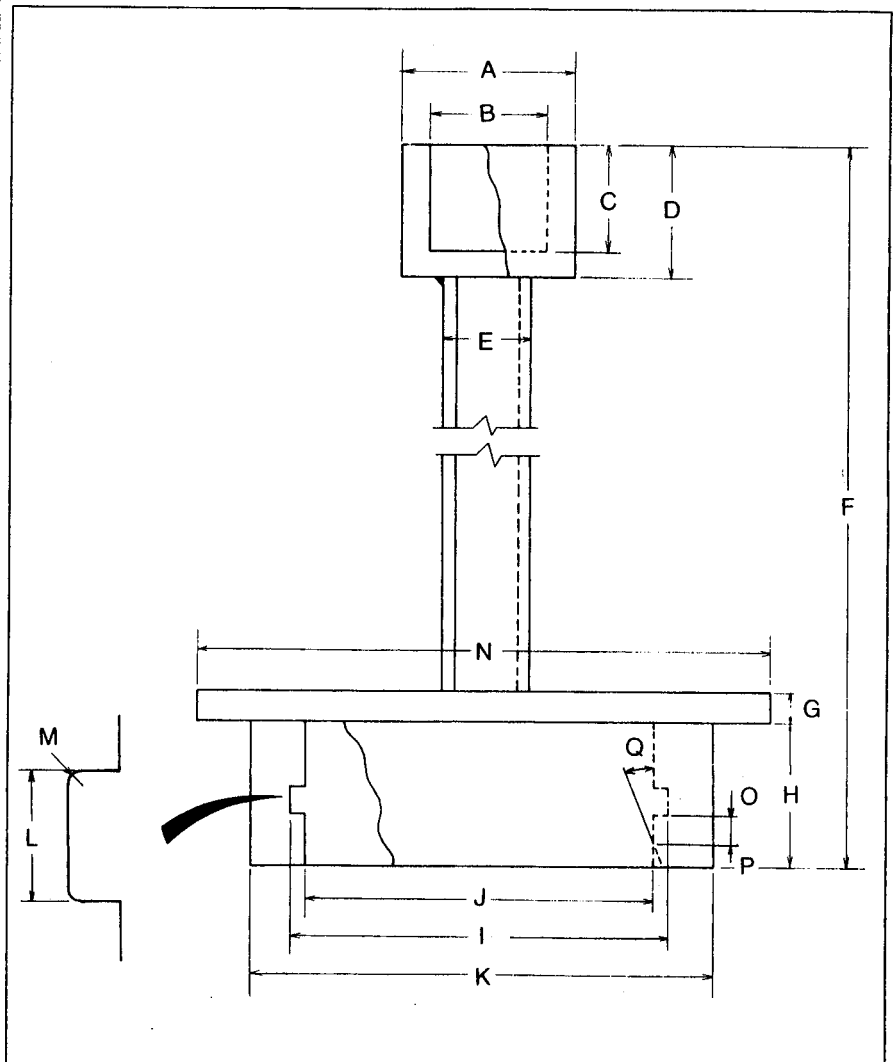

Blank for Suction Strainer

Contents	Page No.
Safety Notices	1 - 1
General Safety	2 - 1
Operating Safety	3 - 1
Maintenance Safety	4 - 1

It is most important that you read and understand this information and the publications referred to. Make sure that all of your colleagues who are concerned with lubricants read it too.

First Aid - Oil

Swallowing.

If oil is swallowed you should not induce vomiting. Get medical advice.

Skin

In the case of excessive skin contact you should wash with soap and water.

Eyes

In the case of eye contact, flush with water for 15 minutes. If irritation persists, get medical attention.

Fires

Extinguish with carbon dioxide, dry chemical or foam. Firefighters should use self contained breathing apparatus.

WARNING

Do not use water to put out an oil fire. This will only spread it because oil floats on water.

Extinguish oil and lubricant fires with carbon dioxide, dry chemical or foam. Fire fighters should use self contained breathing apparatus.

7-3-1-3/1

Hygiene

JCB lubricants are not a health risk when used properly for their intended purposes.

However, excessive or prolonged skin contact can remove the natural fats from your skin, causing dryness and irritation.

Low viscosity oils are more likely to do this, therefore particular care is necessary in handling used oils which can be diluted with fuel contamination.

Whenever you are handling oil products you should maintain good standards of care and personal and plant hygiene. For details of these precautions we advise you to read the relevant publications issued by your local health authority, and note the following:

Storage

Always keep lubricants out of the reach of children.

Never store lubricants in open or unlabelled containers.

Handling

New Oil

There are no special precautions needed for the handling or use of new oil, beside normal care and hygiene practices.

Used Oil

Used engine crankcase lubricants contain harmful contaminants. In laboratory tests it was shown that used engine oils can cause skin cancer.

Here are precautions to protect your health when handling used engine oil:

- 1 Avoid prolonged, excessive or repeated skin contact with used engine oils.
- 2 Apply a barrier cream to the skin before handling used engine oil.
- 3 Note the following when removing engine oil from skin:
 - a Wash your skin thoroughly with soap and water.
 - b Using a nail brush will help.
 - c Use special hand cleansers to help clean dirty hands.
 - d Never use petrol, diesel fuel or gas oil.
 - e Avoid skin contact with oil soaked clothing.
 - f Don't keep oily rags in pockets.
 - g Wash dirty clothing before re-use.
 - h Throw away oil-soaked shoes.

Waste Disposal

All waste products should be disposed of in accordance with all the relevant regulations.

The collection and disposal of used engine oil should be in accordance with any local regulations. Never pour used engine oil into sewers or drains.

Spillage

Absorb on sand or a locally approved brand of absorbent granules. Scrape up and remove to a chemical disposal area.

Changing the Return Filter Element

1 Prepare the Machine

Position the machine on level ground. Stop the engine. Remove the starter key.

2 Locate the Return Filter

Refer to **Component Location Diagrams** at the end of this section.

3 Release Tank Pressure

See **Releasing Tank Pressure**.

4 Remove the Element

- Remove the retaining bolts **B** and take off cover plate **C** complete with its 'O' ring seal.
- Remove spring **D**, by-pass valve **E** and element **F**.

5 Fit a New Element

Re-assemble in reverse order using a new filter element **F** and a new cover plate 'O' ring.

6 Seal the System

- JS200LC, JS240LC - refit filler cap **A** by lining up the alignment marks and tighten fully. The retaining pin will spring back to secure the filler cap.
- JS300LC, JS450LC - refit filler plate **P** and secure with bolts **G**.

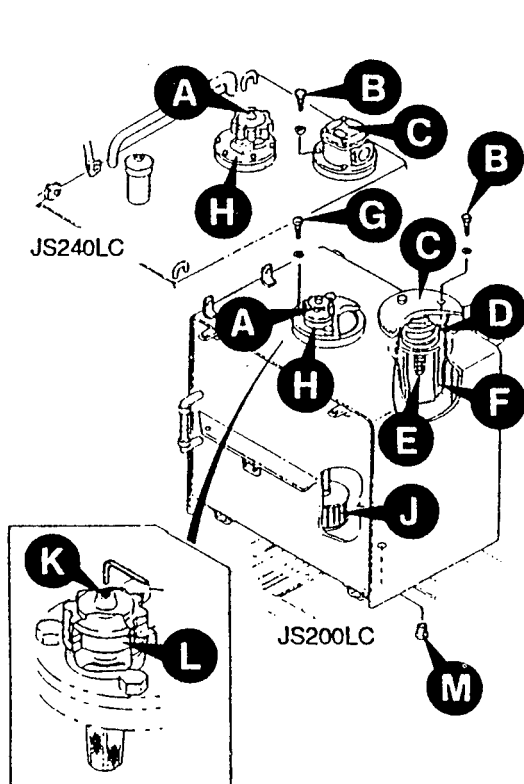

JS200LC, JS240LC

Cleaning/Changing the Suction Strainer

1 Prepare the Machine

Position the machine on level ground. Stop the engine. Remove the starter key.

2 Locate the Suction Strainer

Refer to **Component Location Diagrams** at the end of this section.

3 Release Tank Pressure

See **Releasing Tank Pressure**.

4 Remove the Suction Strainer

- Remove retaining bolts **G** and lift off cover **H** (JS200LC, JS240LC) or **P** (JS300LC, JS450LC).
- Remove the suction strainer **J** and clean with a suitable solvent, or, if renewing, discard.

5 Fit the suction strainer

Fitting is a reversal of removal. When changing the suction strainer, fit a new 'O' ring seal to cover **H**.

6 Check the Hydraulic Fluid Level.

7 Seal the System

- JS200LC, JS240LC - refit filler cap **A** by lining up the alignment marks and tighten fully. The retaining pin will spring back to secure the filler cap.
- JS300LC, JS450LC - refit filler plate **P** and secure with bolts **G**.

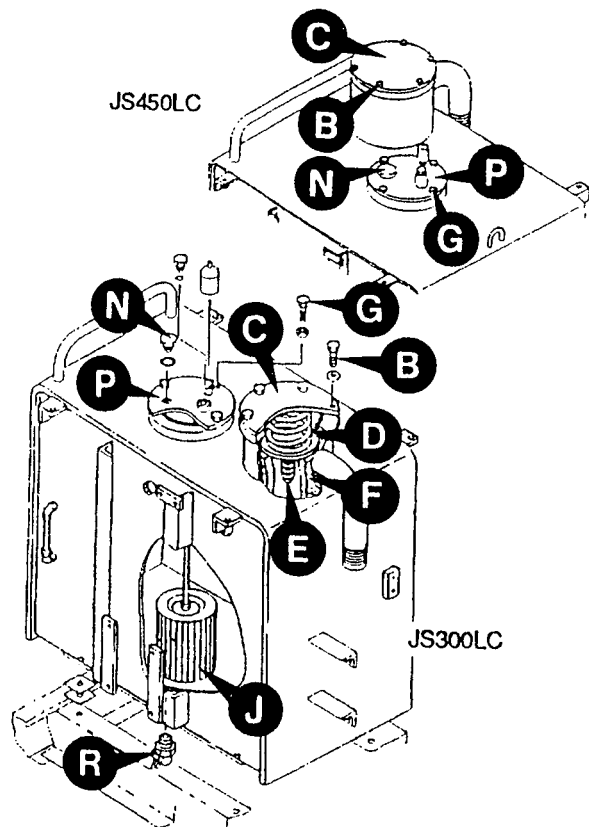

JS300LC, JS450LC

Changing the Air Filter Inner Element

1 Locate the Air Filter

See *Component Location Diagrams* at the end of this section.

2 Clean the Pre-Cleaner (if fitted)

3 Stop the Engine

Remove the starter key.

4 Open the Hydraulic Compartment

5 Disconnect the Filter Induction Hose

To prevent dust getting into the engine, disconnect the induction hose **A**. Cover the hose to prevent rain and dirt getting into the engine.

6 Remove the End Cover

Unscrew knob **G**. Pull off the end cover **H**.

7 Remove the Outer Element

Unscrew nut **E**. Pull out the outer element **J**.

8 Remove the Inner Element

Unscrew nut **K**. Pull out the inner element **L**.

9 Clean the Canister

Clean the inside of the canister **D**, the end cover **H** and dust valve **F**.

10 Fit the New Inner Element

Carefully insert the new inner element into the canister. Make sure it seats correctly, by smearing the seal **B** with grease and checking for a witness mark on the canister base. Fit and tighten nut **K**.

11 Fit the Outer Element

Carefully insert the new outer element into the canister. Make sure it seats correctly, by smearing the seal **C** with grease and checking for a witness mark on the canister base. Fit and tighten nut **E**.

12 Fit the End Cover

Fit the end cover **H** onto the canister. Make sure the dust valve **F** is at the bottom. Tighten knob **G**.

13 Connect the Induction Hose

Connect the induction hose. Make sure the air filter blocked switch connector is fitted.

Check all hoses for condition and tightness.

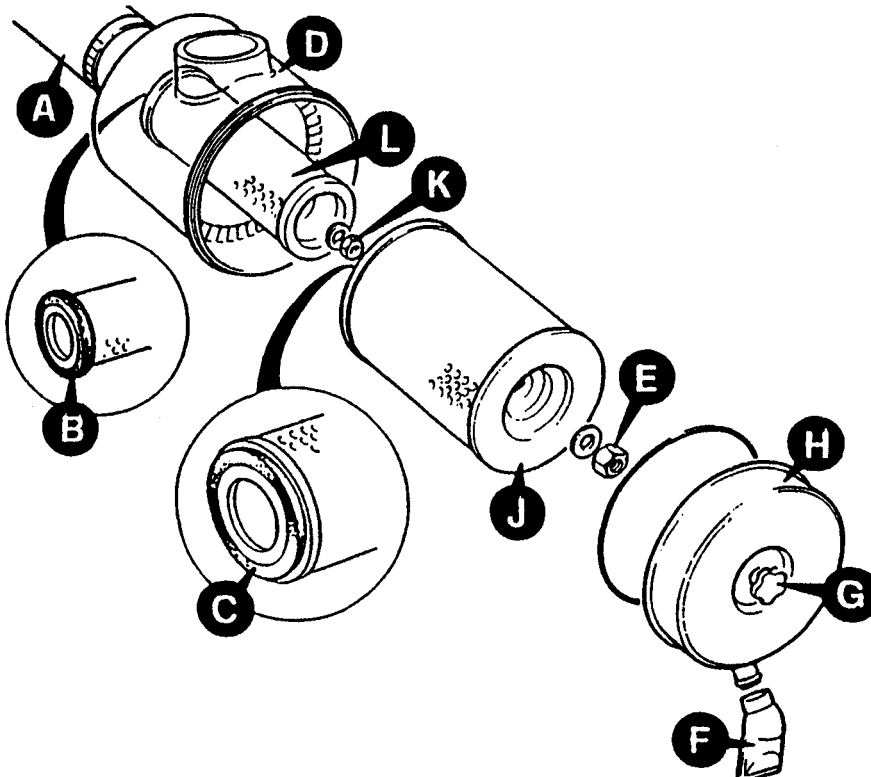

- A - Hydraulic Servo Oil Filter
- B - Fuel Filter
- C - Engine Oil Filter - Full Flow (JS200LC, JS240LC, JS300LC)
- Main (JS450LC)
- D - Engine Oil Filter - By-pass (JS200LC, JS240LC, JS300LC)
- Centrifugal (JS450LC)
- E - Hydraulic Return Filter
- F - Hydraulic Suction Filter
- G - Hydraulic Drain Filter
- H - Air Filter
- J - Hydraulic Oil Tank Filler Cap/Air Breather
- K - Swing Ring Gear
- L - Engine Oil Sump Drain Plug
- M - Swing Gearbox
- N - Hydraulic Oil Tank Filler Plate
- P - Engine Cooling Radiator
- R - Fuel Tank Filler Cap

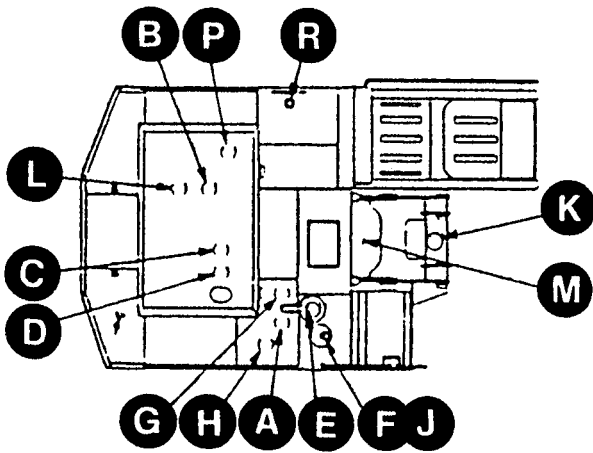

JS200LC

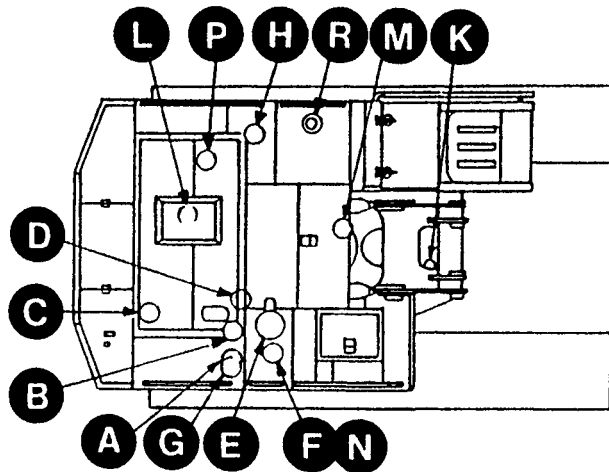

JS300LC

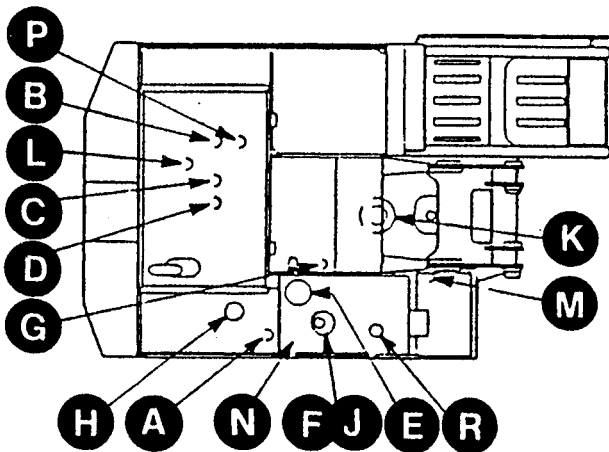

JS240LC

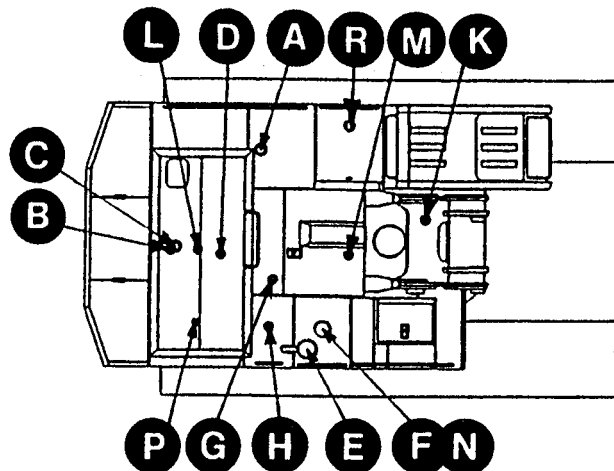

JS450LC

SMCU-1 Controller Block Diagram

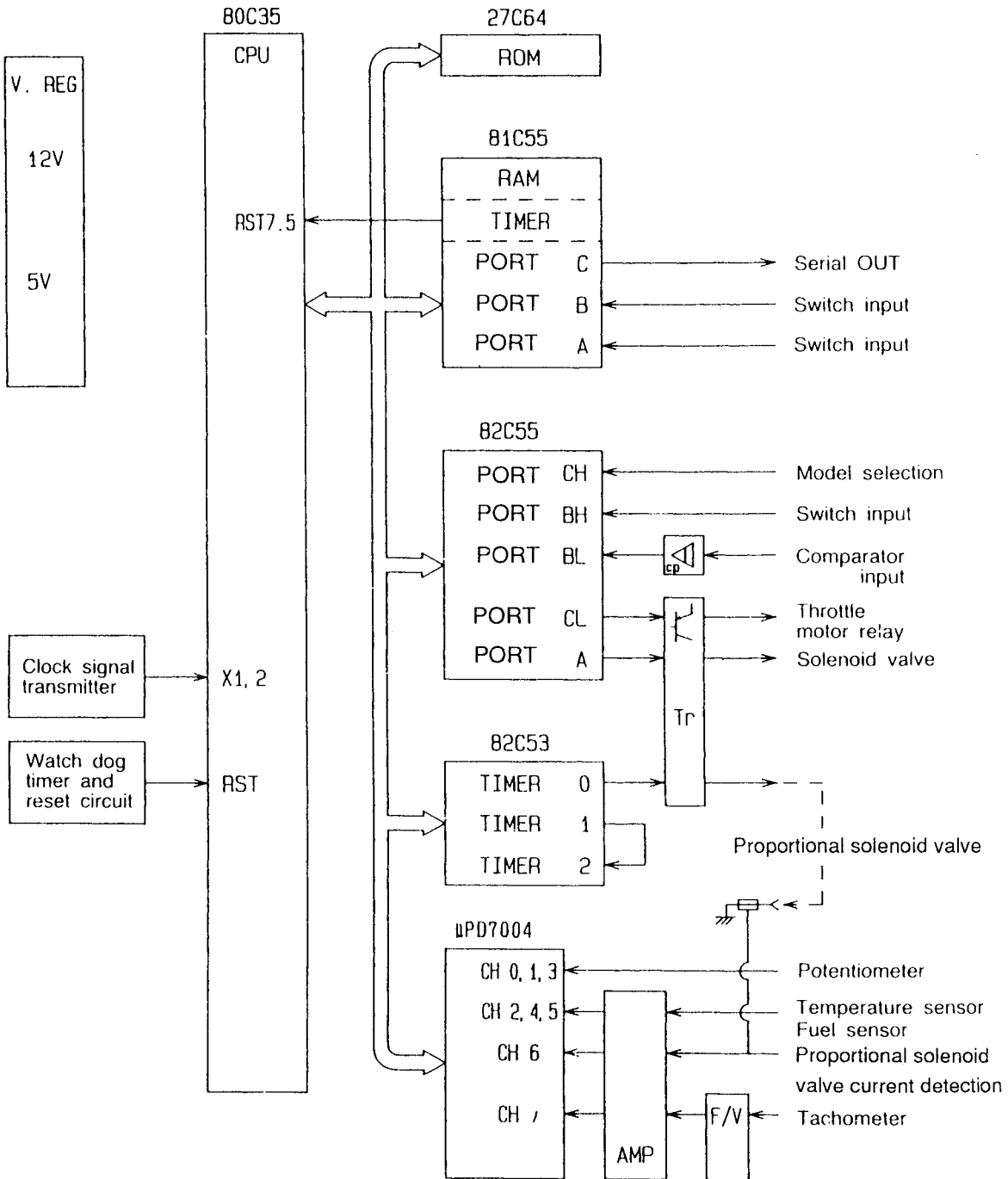

Removal and Replacement

Removal

1. Remove the Systems Control Monitor as detailed on pages 6-9 and 6-10 of this Section.

2. Remove the printed circuit board retaining screws.

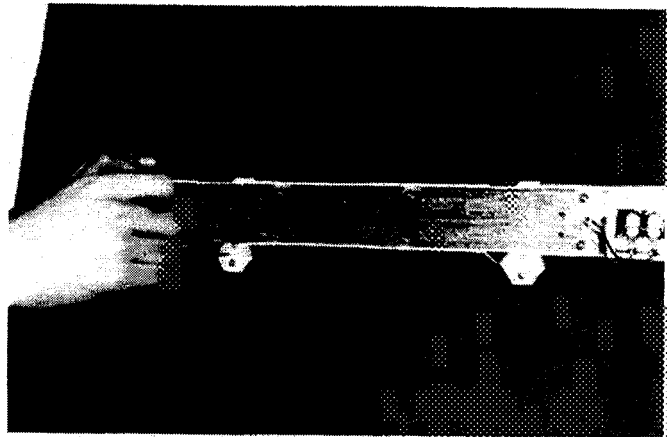

3. Disconnect the wiring between the hour meter and the printed circuit board at the hour meter.

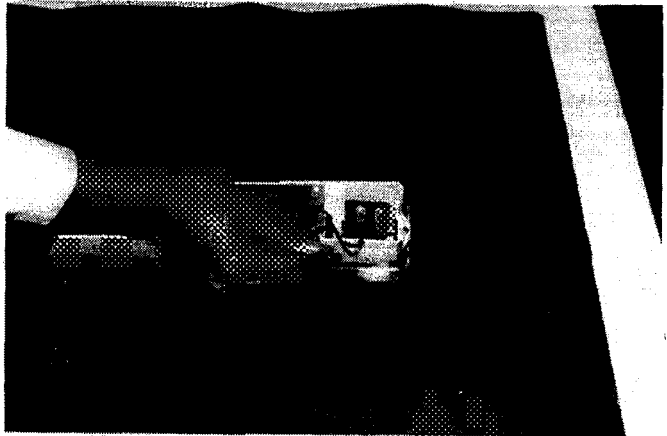

4. Disconnect the wiring between the printed circuit board and the indicator and remove the printed circuit board.

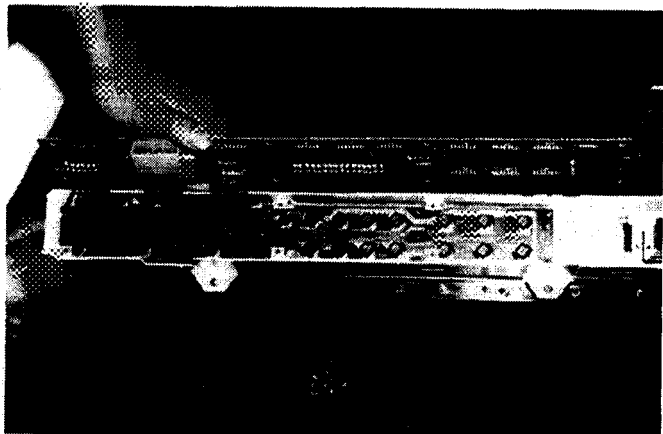

Controller Plug Pin Connections JS 200, 240, 300, 450LC

CN 2(G)

- 1 SW 1 (SWING PRESSURE SWITCH)
- 2 SW 2 (2-SPEED TRACK SWITCH)
- 3 SW 3 (ENGINE STOP)
- 4 SW 4 (F2)
- 5 SW 5 (F1)
- 6 SW 6 (IDLE)
- 7 FREE SWING
- 8 DO 2 (2-SPEED TRACK)
- 9 HEAT RELAY
- 10 OIL PRESSURE SWITCH
- 11 (No Connection)
- 12 AIR FILTER
- 13 RESERVE FUEL TANK LEVEL SWITCH

CN 3

- 1 FUEL LEVEL SENSOR
- 2 OIL TEMPERATURE
- 3 WATER TEMPERATURE
- 4 BATTERY LEVEL SENSOR
- 5 ENGINE ROTATION
- 6 (No Connection)
- 7 AV
- 8 THROTTLE SENSOR
- 9 AG

CN 4

- 1 A
- 2 GND
- 3 B
- 4 C MODEL
- 5 GND
- 6 D
- 7 H MODE
- 8 S
- 9 L
- 10 F (MODEL R3)
- 11 BATTERY CHARGE
- 12 (No Connection)
- 13 SW 7 (FREE SWING SWITCH)

CN 1

- 1 AV
- 2 THROTTLE VOLUME
- 3 AG
- 4 BUZZER OFF SWITCH
- 5 IDLE SWITCH
- 6 MANUAL PRE-HEAT
- 7 PROPORTIONAL SOLENOID RETURN
- 8 OUT
- 9 SWING BRAKE
- 10 THROTTLE LEFT
- 11 THROTTLE RIGHT
- 12 24V
- 13 (CONTROL)
- 14 24V
- 15 (DRIVE)
- 16 GND
- 17 GND

**Schematic Hydraulic Circuit JS 200LC
(To Machine No. 704074)**

Component Key

PS	Servo Pump	33	Servo Isolator Solenoid Valve
P1	No. 1 Pump Element	34	Check Valve
P2	No. 2 Pump Element	35	Servo Filter
M	Engine	36	Boom Down Negative Control Delay Solenoid Valve
1	Swing Brake Release Solenoid Valve	36A	Boom Down Negative Control Delay Switch
1A	Swing Parking Brake Release Switch	37	Hydraulic Pump
2	Shuttle Valve	37A	Proportional Solenoid Valve
3	Swing Motor	37B	Summator Assembly
3A	Cross Line Relief Valves	37C	Pump Control (Swing Operation)
4	Free Swing Restrictor	38	Servo Pump Relief Valve
5	Free Swing Solenoid	39	Speed Change Solenoid Valve
6	Reverse Prevention Valve		
7	Dipper Ram		
8	Dipper Hose Burst Check Valve		
9	Track Motor LH		
9A	Counterbalance Spool		
9B	Brake Release Piston		
9C	Cross Line Relief Valves		
9D	Speed Selector Control Spool		
9E	Speed Actuators		
10	Track Motor RH		
11	Rotary Coupling		
12	Bucket Ram		
13	Boom Rams		
14	Boom Hose Burst Check Valves		
15	Control Valves (A & B)		
15A	Neative Control Pressure Relief Valves		
15B	Track Left Spool		
15C	Dipper Spool		
15D	Swing Spool		
15E	Track Right Spool		
15F	Option Spool		
15G	Bucket Spool		
15H	Boom Spool		
15J	Main Relief Valve (A)		
15K	Main Relief Valve (B)		
15L	Dipper Rod Side ARV		
15M	Dipper Head Side ARV		
15N	Bucket Rod Side ARV		
15P	Bucket Head Side ARV		
15R	Boom Head Side ARV		
15S	Boom Rod Side ARV		
15T	Logic Valves		
16	Restrictor		
17	Cooler		
18	Cooler Check Valve (0.5 bar/7.25 lb in ²)		
19	Tank Breather		
20	Cooler Check Valve (1.96 bar/28.4 lb in ²)		
21	Return Filter (10μ)		
22	Filter By-pass Relief Valve (0.98 bar/14.2 lb in ²)		
23	Suction Strainer		
24	Warm Up Filter (100 x 800 Mesh)		
25	Hydraulic Tank		
26	Drain Filter (10μ)		
27	Servo Hand Control Valve LH		
28	Servo Hand Control Valve RH		
29	Cushion Valve		
30	Cushion Valve Solenoid Valve		
31	Servo/Drain Manifold		
32	Accumulator		

JS 200LC, 300LC (cont'd)

SYMPTOM	POSSIBLE CAUSE	ACTION
<p>2. Hydraulic Pump (cont'd)</p> <p>b. Insufficient flow rate.</p>	<ol style="list-style-type: none"> 1. The speed of the input shaft is too low. 2. Hydraulic oil temperature is too high. 3. Hydraulic oil viscosity is too low. 4. Leakage of the selector valves or actuators. 5. Low pump volumetric efficiency. 6. Power adjusting screw is loose. 7. Air in system due to low oil level. 8. Pressure loss due to blocked filter. 9. Pressure loss due to high hydraulic oil viscosity in cold periods. 10. The external command pressure exceeds the upper limit. 11. Power setting is low due to a change in the pressure reduction of the secondary choke. 12. Defective solenoid pressure reduction valve. 	<p>Check speed and readjust if necessary.</p> <p>Stop operation and check the oil temperature.</p> <p>Check the temperature and type of hydraulic oil used, renew if necessary.</p> <p>Check if the leakage occurs in a particular actuator only. Renew the actuator or selector valve.</p> <p>Check if the problem occurs in a particular pump only, if so renew the pump.</p> <p>Check if the locknuts are loose, reset and lock if necessary.</p> <p>Check the hydraulic oil level, replenish if necessary.</p> <p>Check the filter elements and clean or renew as necessary.</p> <p>Check the temperature of oil and warm if necessary. Check type of hydraulic oil, renew with correct type if wrong type used.</p> <p>Measure pressure and readjust if necessary.</p> <p>Check the operation of the secondary choke. Dismantle and clean.</p> <p>Check and renew the valve if necessary.</p>
<p>c. No rise in pressure.</p>	<ol style="list-style-type: none"> 1. Relief valve is set too low. 2. Selector valves or actuators leaking. 3. Low pump volumetric efficiency. 	<p>Check pressure in the circuit, and readjust the relief valve as necessary.</p> <p>Check the operation of each actuator and valve and renew any which are defective.</p> <p>Check if the problem occurs in a particular pump only, if so renew the pump.</p>

JS 200LC

⚠ WARNING

Before undertaking the following procedure the machine must be parked on level ground and in a safe condition with the bucket resting on the ground.

HYD 6-4

⚠ WARNING

DO NOT remove the hydraulic tank filler cap or cover plate when the engine is running. The hydraulic system is under pressure. You or others could be injured. First stop the engine and then release the pressure.

8-3-4-4/1

- * Pressure settings should be checked in the following sequence against the figures shown in Technical Data, page E/1-1. For all checks, use the pressure gauges detailed in Section 1.

Unless otherwise stated, all pressure tests should be undertaken at maximum speed in the 'S' mode with the swing lock lever lowered.

Note 1: Both engine and hydraulic oil must be at operating temperatures, with the warm-up lamp **OUT**, before undertaking the following procedures.

Note 2: Always set the final pressure by bringing the pressure **UP** to the correct setting from a lower pressure.

Note 3: Where system pressure has to be released, stop the engine, set the starter switch to **ON**, the operation control switch to **ON** and lower the servo isolator lever/left arm rest. Release hydraulic pressure by moving the control levers several times and slowly removing the hydraulic tank cap and replacing it.

1. Accumulator Pressure

1.1 With the servo isolator lever/left arm rest **lowered**, start the engine. Set the operation control switch to **ON**.

1.2 Raise the boom to its full height and stop the engine. Move the boom operating lever fully from neutral to lower and back to neutral and check that the boom begins to lower and then stops. Repeat six times, checking whether the boom lowers each time.

1.3 If the boom lowers three times or more the gas pressure in the accumulator is satisfactory.

1.4 If the boom lowers twice or less, check servo pressure (see operation 2). If servo pressure satisfactory, renew the accumulator.

1.5 Where necessary, start the engine and lower the boom to rest bucket on the ground. Set the control switch to **OFF** and stop the engine.

2. Servo Pressure

- * 2.1 Release system pressure as detailed in Note 3. Connect a 0 to 70 bar (0 to 1000 lb/in²) pressure gauge to the servo pressure test point P3, see A.

2.2 Start the engine and set engine speed to maximum in the 'S' mode.

- * 2.3 Check the pressure reading. If necessary, adjust the servo pressure at the servo pump relief valve **S**, see **B**. One turn of the adjusting screw equals 15.7 bar (228 lb/in²). Repeat as required.

- * 2.4 Release system pressure as detailed in Note 3. Remove the pressure gauge and replace the cap.

3. Main Relief Valve Pressure

- * 3.1 Release system pressure as detailed in Note 3. Connect a 0 to 400 bar (0 to 5800 lb/in²) pressure gauge to the P1 pressure test point, see **C**.

3.2 Lock LH track motor by placing a steel bar 76 mm diameter x 203 mm long (3.0 ins. diameter x 8 ins. long) between the drive sprocket and the side frame.

3.3 Start the engine. Slowly engage the LH track until the track motor stalls. Release the track lever.

3.4 Set engine speed to maximum in the 'S' mode.

3.5 Slowly engage the LH track and measure the pressure. If necessary, adjust the pressure at 1, see **D**. One turn of the adjusting screw equals 196 bar (2844 lb/in²).

Note: If the pressure setting can not be attained, the track cross line relief valve setting may be controlling the pressure. Check the track cross line relief valve settings as detailed in operation 6.

- * 3.6 Release system pressure as detailed in Note 3. Move the pressure gauge to pressure test point P2, see **C**.

3.7 Repeat operations 3.2 to 3.5 for the RH track, adjusting the pressure as necessary at 2, see **D**.

- * 3.8 Release system pressure as detailed in Note 3. Remove the pressure gauge from the pressure test point and replace the caps. Remove the track lock bars.

4. Auxiliary Relief Valves (ARV's)

- * 4.1 Release system pressure as detailed in Note 3. Connect a 0 to 400 bar (0 to 5800 lb/in²) pressure gauge to pump pressure test point P1, see **B**.

4.2 With the servo isolator lever/left arm rest **lowered**, start the engine. Set engine speed to maximum in the 'S' mode and the operation control switch to **ON**.

- * 4.3 Operate the dipper out service to the limit of dipper travel and hold to check the ARV pressure setting. Repeat for dipper in. If necessary, raise the servo isolator/left arm rest and adjust at the control valve, see **E**, at 6 for dipper out and 5 for dipper in. One turn of the adjusting screw equals 196 bar (2844 lb/in²). Repeat as required.

JS 300LC

⚠ WARNING

Before undertaking the following procedure the machine must be parked on level ground and in a safe condition with the bucket resting on the ground.

HYD 6-4

⚠ WARNING

DO NOT remove the hydraulic tank filler cap or cover plate when the engine is running. The hydraulic system is under pressure. You or others could be injured. First stop the engine and then release the pressure.

8-3-4-4/1

*Pressure settings should be checked in the following sequence against the figures shown in Technical Data, page E/1-3. For all checks, use the pressure gauges detailed in Section 1.

For all checks, the swing lock lever must be lowered.

Note 1: Both engine and hydraulic oil must be at operating temperatures, with the warm-up lamp **OUT**, before undertaking the following procedures.

Note 2: Always set the final pressure by bringing the pressure **UP** to the correct setting from a lower pressure.

Note 3: Where system pressure has to be released, stop the engine, set the starter switch to **ON**, the operation control switch to **ON** and **lower** the servo isolator/left arm rest. Release hydraulic pressure by moving the hand control levers several times and loosen the hydraulic tank air release plug until all pressure has escaped. Tighten the plug.

1. Accumulator Pressure

- 1.1 With the servo isolator/left arm rest **lowered**, start the engine. Set the control switch to **ON**.
- 1.2 Raise the boom to its full height and stop the engine. Move the boom operating lever fully from neutral to lower and back to neutral and check that the boom begins to lower and then stops. Repeat six times, checking whether the boom lowers each time.
- 1.3. If the boom lowers three times or more the gas pressure in the accumulator is satisfactory.
- 1.4 If the boom lowers twice or less, check servo pressure (see operation 2). If servo pressure satisfactory, renew the accumulator.
- *1.5 Where necessary, start the engine and lower the boom to rest the bucket to the ground. Set the control switch to **OFF** and stop the engine.

2. Servo Pressure

- *2.1 Release system pressure as detailed in **Note 3**. Connect a 0 to 70 bar (0 to 1000 lb in²) pressure gauge to the servo pressure test point **P3**, see **A**.
- 2.2 Start the engine and set engine speed to maximum in the 'S' mode.

- 2.3 Check the pressure reading. If necessary, adjust the servo pressure at the servo pump relief valve **S**, see **A**. One turn of the adjusting screw equals 13.8 bar (200 lb/in²). Repeat as required.

- * 2.4 Release system pressure as detailed in **Note 3**. Remove the pressure gauge and replace the cap.

3. Main Relief Valve Pressure

Note: If it is necessary to check either the track or swing cross over relief valves, it is recommended that operations 5 and/or 6 are undertaken before the MRV pressures are set.

- * 3.1 Release system pressure as detailed in **Note 3**. Connect a 0 to 400 bar (0 to 5800 lb/in²) pressure gauge to the **P1** pressure test point, see **B**.
- 3.2 Lock the **RH** track motor by placing a steel bar 76 mm diameter x 203 mm long (3.0 ins. diameter x 8 ins. long) between the drive sprocket and the side frame.
- 3.3 With the servo isolator/left arm rest **lowered**, start the engine. Set the operation control switch to **ON**. Slowly engage the **RH** track until the track motor stalls. Release the track lever.
- 3.4 Set engine speed to maximum in the 'S' mode. Slowly engage the **RH** track and measure the pressure. If necessary, **raise** the servo isolator/left arm rest and adjust the pressure at 1, see **C**. One turn of the adjusting screw equals 178 bar (2586 lb/in²). Repeat as required. Remove the track locking bar.

Note: If the pressure setting can not be attained the track cross line relief valve setting may be controlling the pressure. Check the track cross line relief valve settings as detailed in operation 6.

- 3.5 **Raise** the servo isolator/left arm rest. Move the pressure gauge to pressure test point **P2**, see **B**.
- 3.6 Repeat operations 3.2 to 3.4 for the **LH** track, adjusting the pressure as necessary at 2, see **C**.
- * 3.7 Release system pressure as detailed in **Note 3**. Remove the pressure gauge from the pressure test point and replace the caps. Remove the track lock bar.

4. Boom, Bucket and Dipper Auxiliary Relief Valves (ARV's)

- * 4.1 Release system pressure as detailed in **Note 3**. Connect a 0 - 400 bar (0 - 5800 lb/in²) pressure gauge to test point **P1**, see **B**. Referring to operation 3, increase the MRV pressures by one quarter of a turn.
- * 4.2 Set engine speed to maximum in the 'L' mode. **Lower** the servo isolator/left arm rest and set the operation control switch to **ON**.

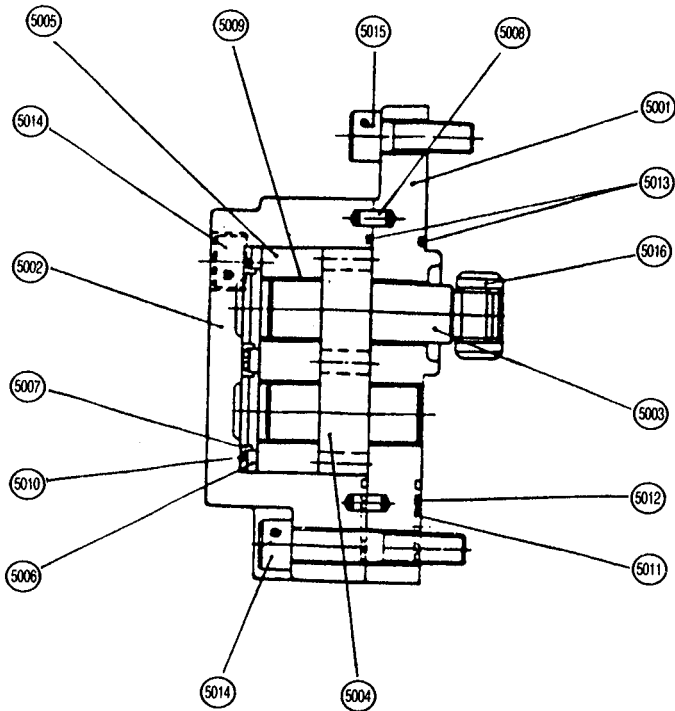
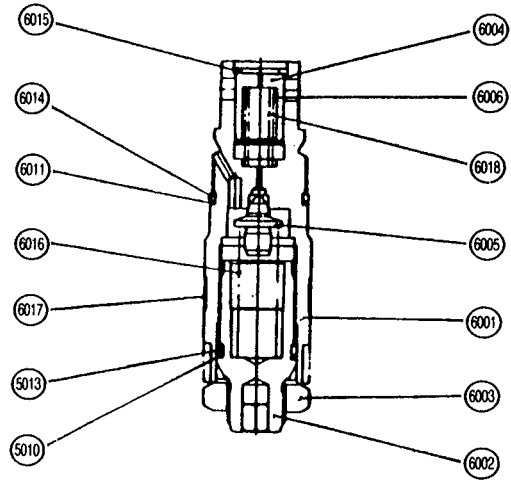
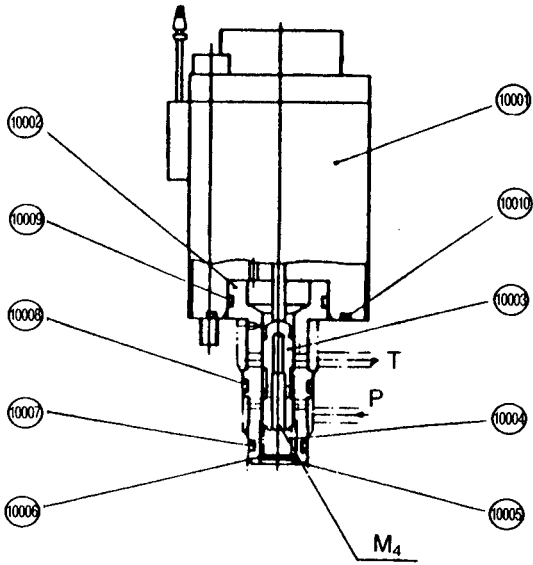

Dismantling - JS 200LC, 300LC (cont'd)

24. Remove plugs 2020 and fastening seals 2043 from each side.

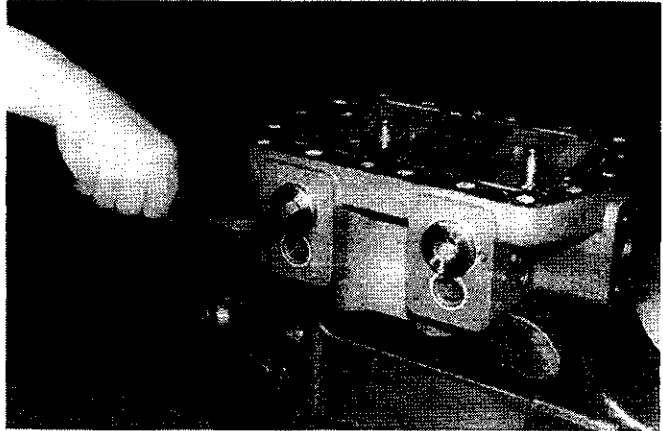

25. Remove the two cap bolts 2040(M10 x 12) from each side.

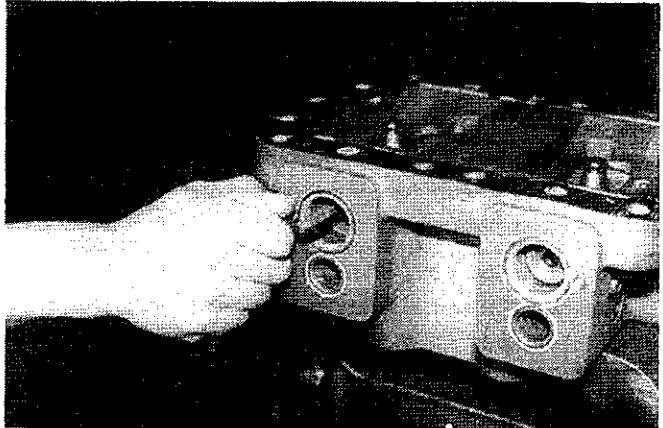

26. Remove rods 2008 from each plunger.

Note: This rod is bound to the plunger with a powerful adhesive and should only be dismantled when absolutely necessary. To remove, heat the rod.

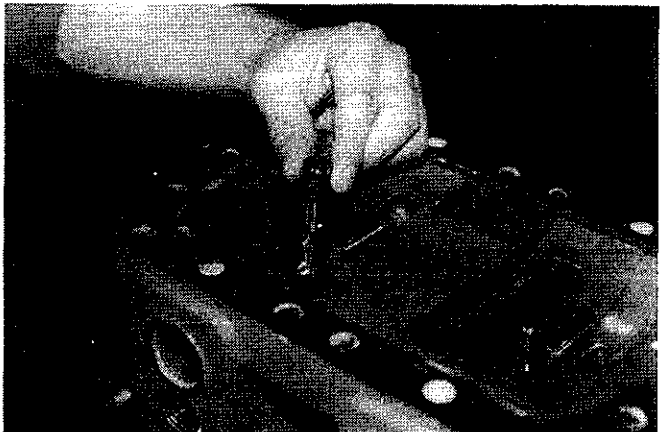

27. Remove plungers 2007 from each side.

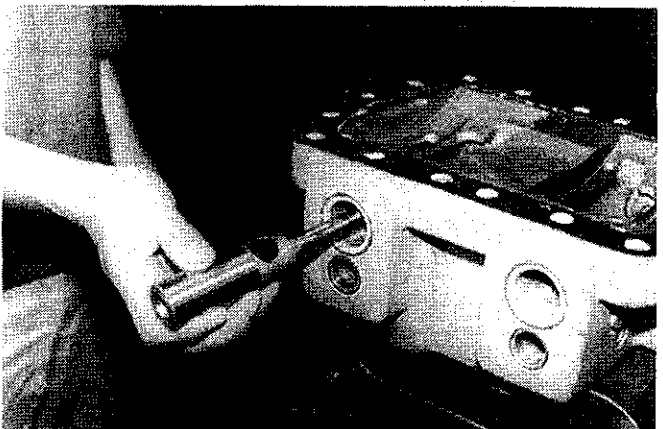

Assembly - JS 200LC, 300LC

Clean each part in a suitable solvent and dry using compressed air.

Inspect all parts and replace as required.

Care must be taken not to let dust or dirt adhere to parts after cleaning and that parts do not become dented, scratched or damaged.

Fit new 'O' rings, plugs, packing, oil seals and fastener seals.

Apply grease to all new oil seals and 'O' rings, and clean hydraulic fluid to all sliding parts before installation.

All tapped holes and gasket faces should be thoroughly degreased by washing as liquid packing and adhesive is used on all gasket surfaces and threads.

Apply adhesive to the final few threads of a bolt or screw. Do not apply excessive amounts of adhesive. Wipe off any surplus liquid packing.

Leave the pump for at least twelve hours after assembly to allow the adhesive to fully dry.

Ensure that the pump controllers are fitted to the positions from which they were removed.

1. Using a heater, warm the holes in the housing which accept the rotary groups to 80 - 85°C.

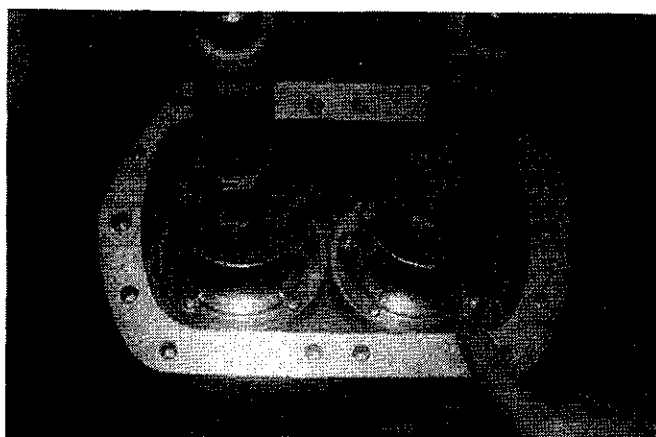

2. Insert the subsidiary rotary group 4001 after lubricating the hole with clean hydraulic fluid.

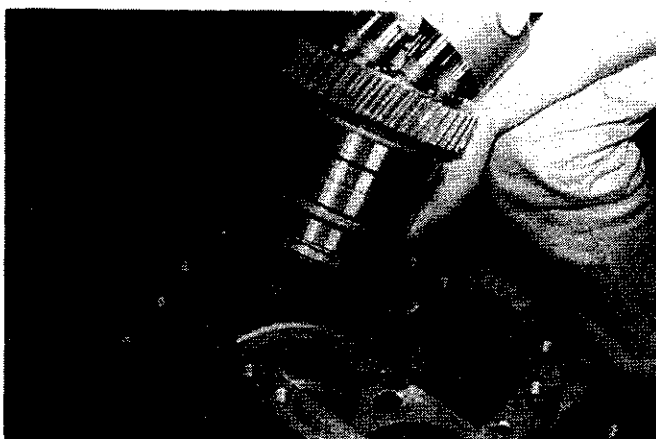

1. Insert the drive rotary group 3001 after lubricating the hole with clean hydraulic fluid.

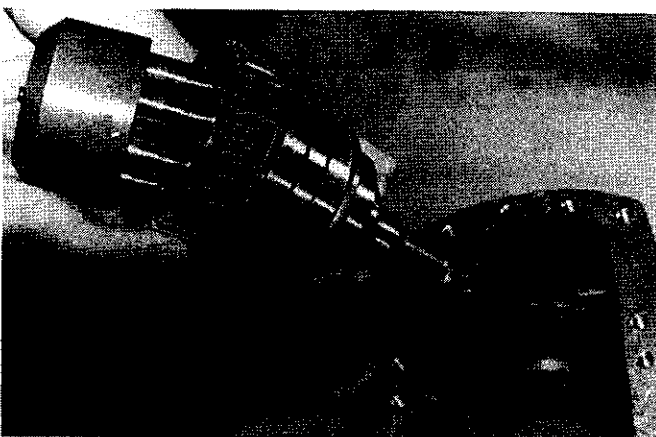

Assembly - JS 200LC 300LC (cont'd)

40. Check that spring seats **8003** are correctly positioned and insert springs **8005** and **8006** into each side.

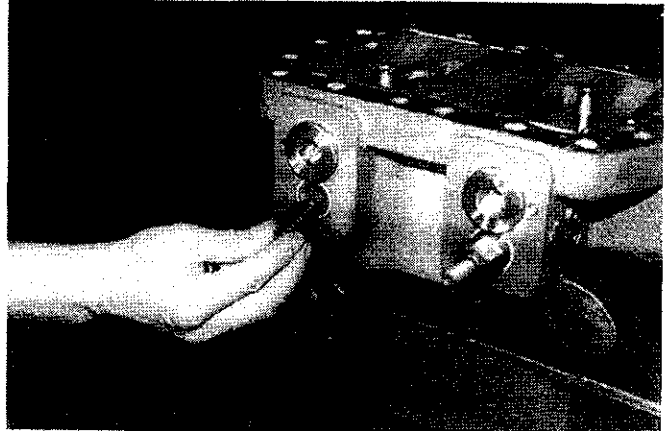

41. Fit 'O' rings **8009** onto guides **8007**. Insert adjusting screw **8004** into the guides.

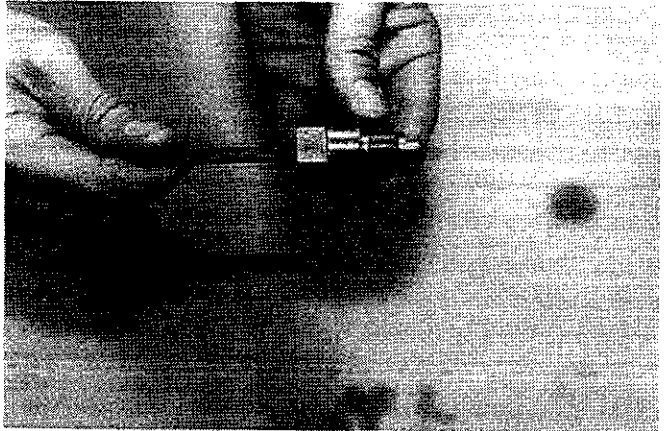

42. Fit guides **8007** to each side. Torque tighten to 88.3 Nm (65.1 lbf. ft.).

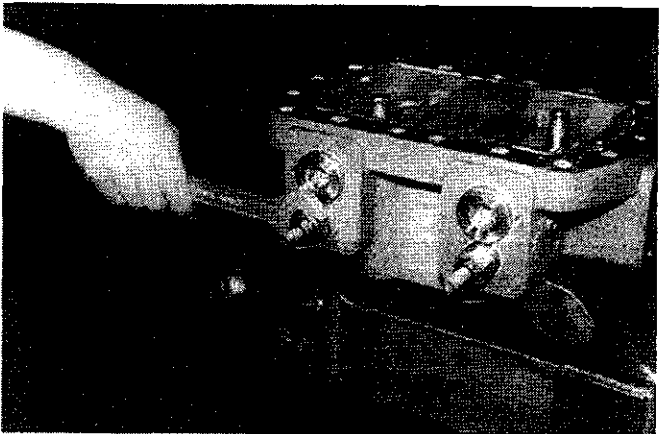

43. Hold adjusting screw **8004** in position using an Allen key and tighten lock nut **8008**. Torque tighten to 49 Nm (36.2 lbf. ft.).

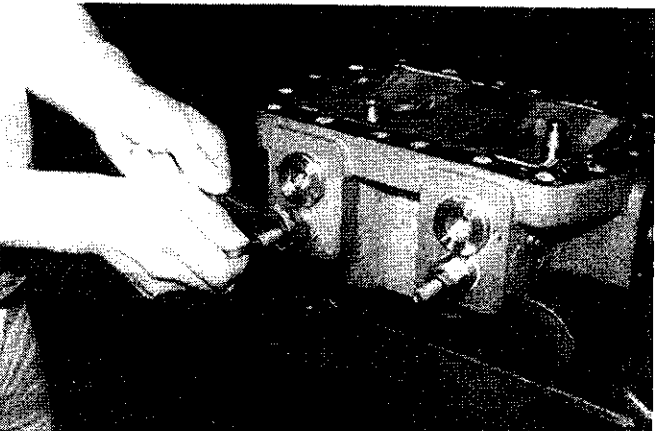

Dismantling - JS240 (cont'd)

- 12 I** The two needle bearings **P124** may be removed from the valve block shaft if required, however, do not remove these bearings unless damage is apparent or suspected.
- II** Remove the circlip **P833**. The roller bearing **P123** can then be removed from the drive shaft (**P111** for front, **P113** for rear).
-

Pump Assembly - JS240 (cont'd)

- 9 Mount the valve block assembly **P312** to the front pump casing **P271**, using bolts **P431** (4 off). Torque tighten to 235.5 Nm (173.6 lbf ft, 24 kg m).

Fit an eye bolt to the end of drive shaft **P111** and raise the front pump/valve assembly. Stand the rear pump on its cover and lower the front pump/valve assembly onto it. Fit bolts **P431** (4 off) and torque tighten to 235.5 Nm (173.5 lbf ft, 24 kg m).

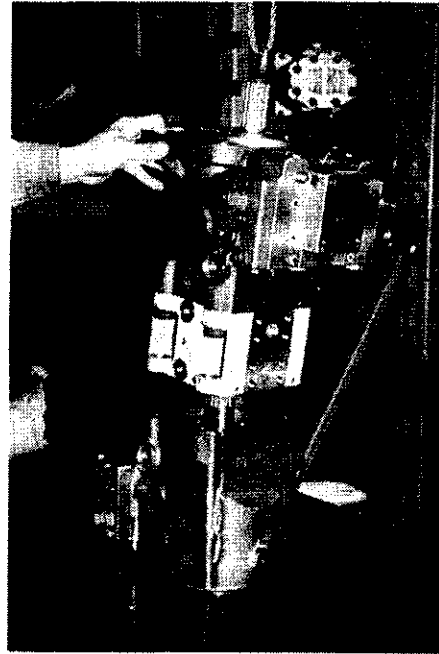

- 10 Refit the seal pipes (**P274** for front, **P278** for rear), together with the relevant 'O' ring **P722** and **P754**. Seal with plugs **P473** and 'O' rings **P732**. Torque tighten the plugs to 29.5 Nm (21.7 lbf ft, 3 kg m).
-

Dismantling - JS450LC (cont'd)

- 20 Remove the two spring seats and withdraw the outer control springs.

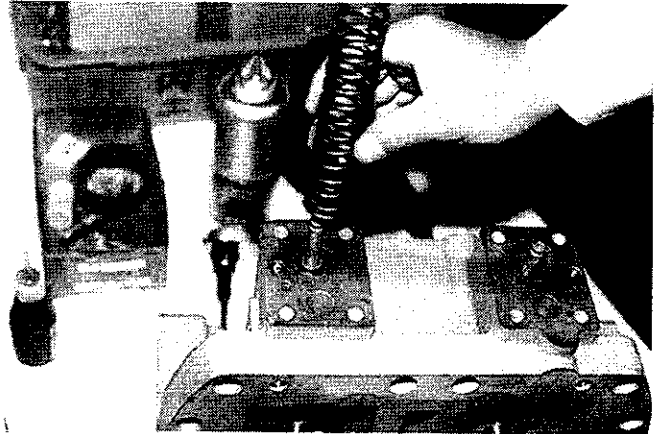

- 21 Remove the shims.

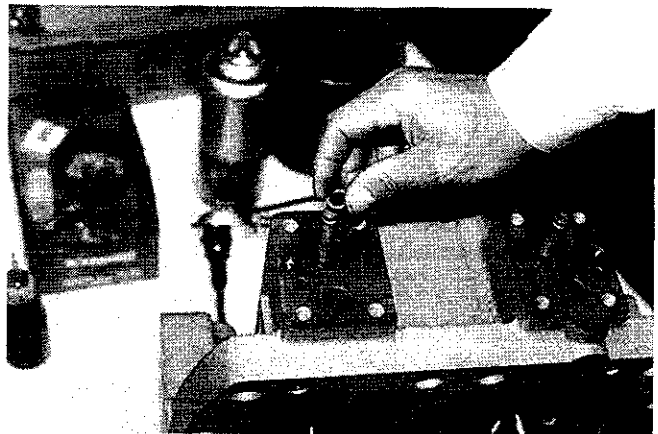

- 22 Withdraw the inner control springs.

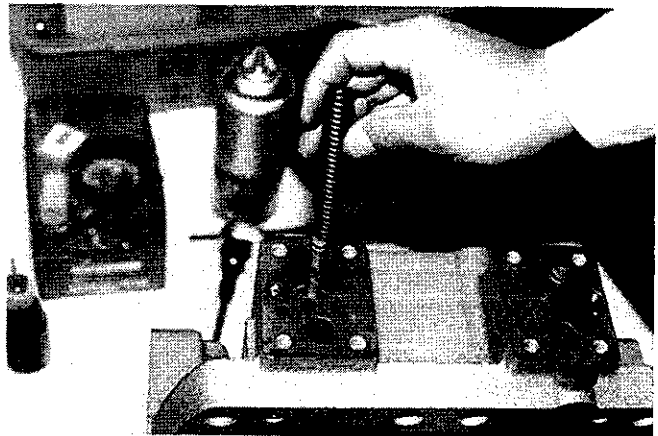

- 23 Remove the spring seats.

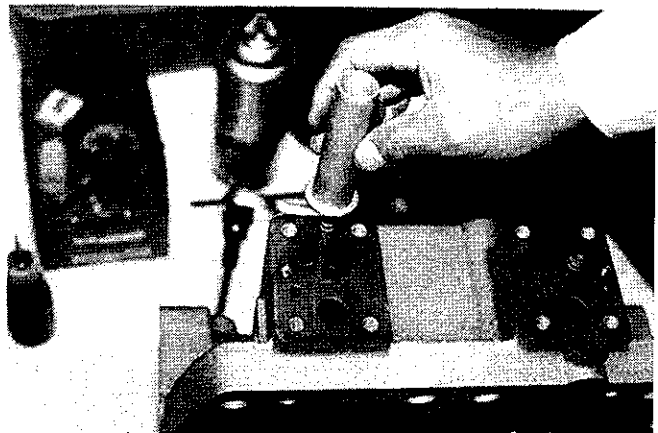

Dismantling - JS450LC (cont'd)

- 56 Use a plastic hammer to knock out the input shaft piston/cylinder assembly.

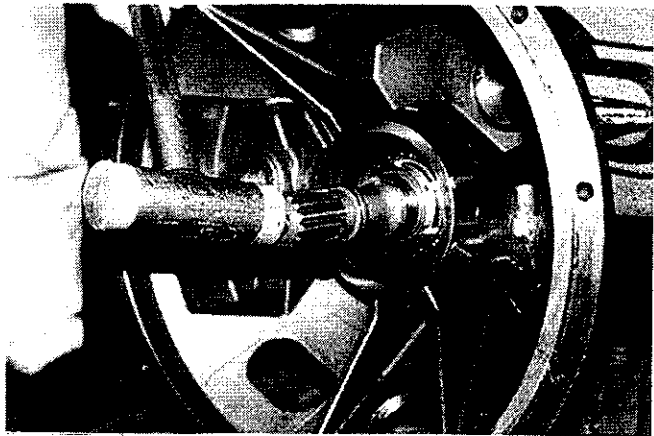

- 57 Remove the circlip. Attach an M6 screw to the retaining plate and withdraw the plate to reveal the bearing inside.

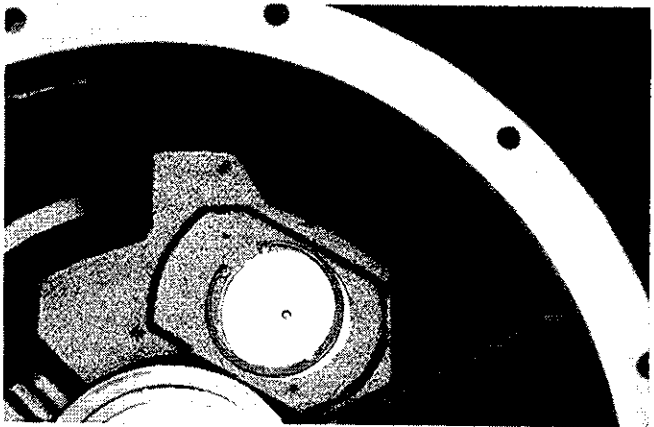

- 58 Withdraw the bearing.

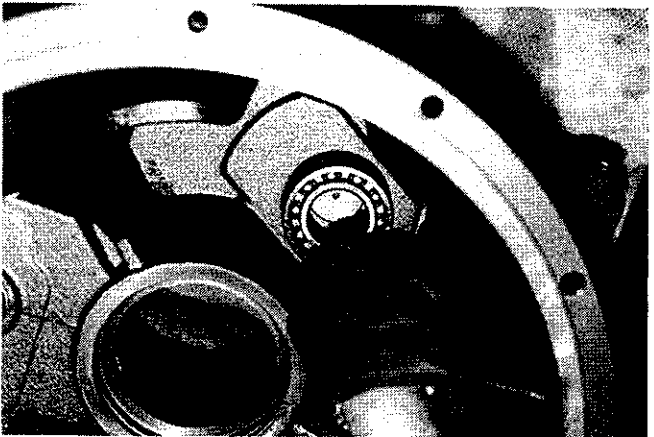

- 59 Remove the shaft, if necessary using a plastic hammer to tap from the opposite side.

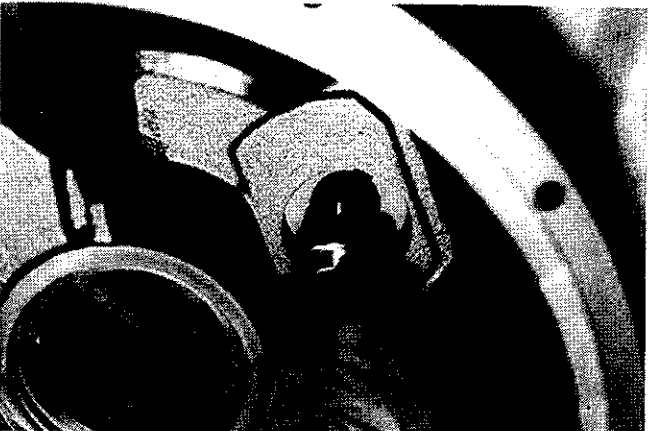

CLICK HERE TO **DOWNLOAD** THE COMPLETE MANUAL

- Thank you very much for reading the preview of the manual.
- You can download the complete manual from: www.heydownloads.com by clicking the link below



- Please note: If there is no response to CLICKING the link, please download this PDF first and then click on it.

CLICK HERE TO **DOWNLOAD** THE COMPLETE MANUAL

Assembly - JS450LC (cont'd)

29 Insert the spring seat.

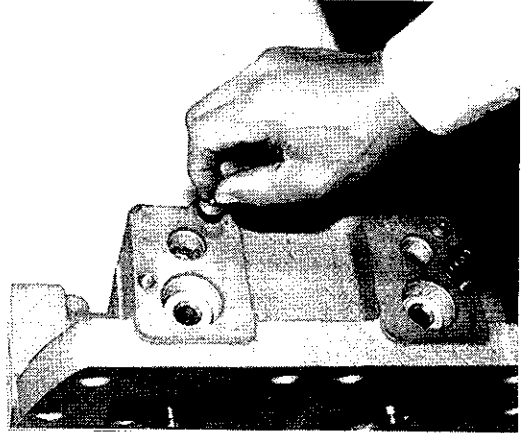

30 Insert the spring.

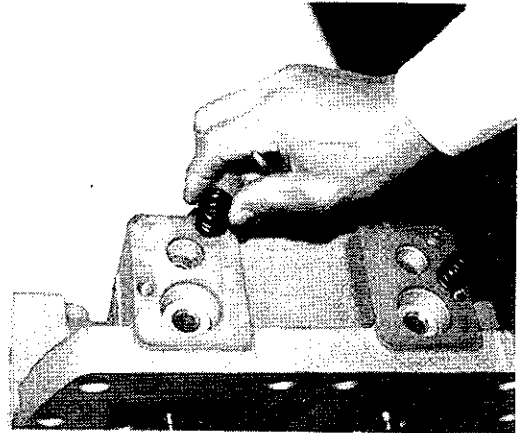

31 Insert the two control springs.

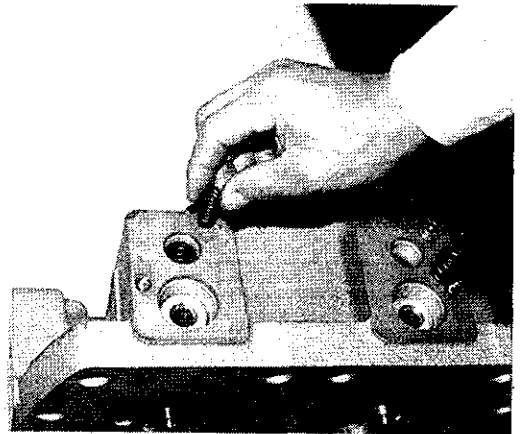

32 Install the two guides and tighten to a torque of 88 Nm (65 lbf ft).

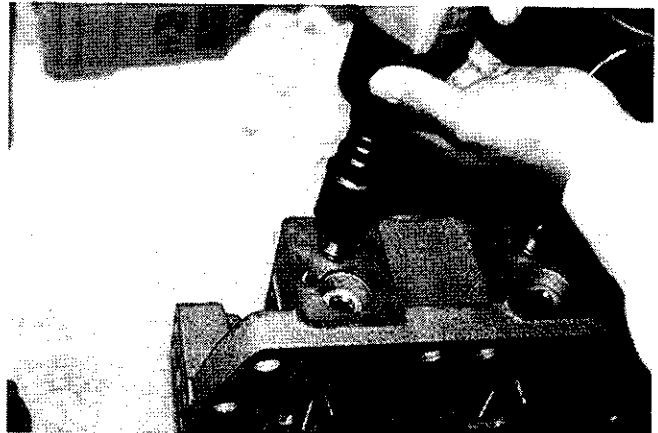



Assembly - JS 200, 240LC

- 8 Install the cover **9** and secure using socket head bolts **10**. Torque tighten bolts to 31.3 - 37.3 Nm (23.1 - 27.5 lbf ft).

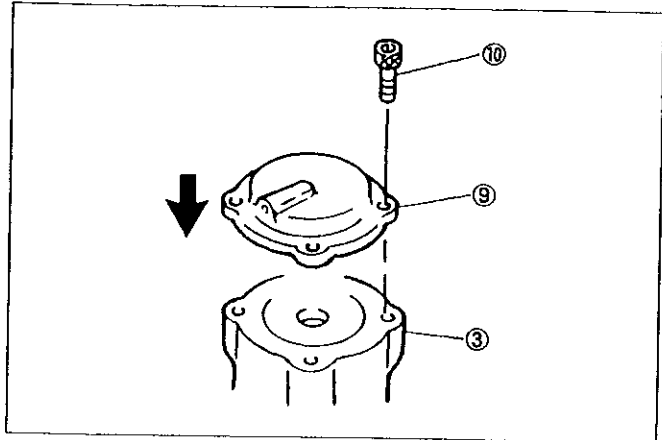

Dismantling - JS 200LC (cont'd)

24. Remove spring 4 from cylinder 23.

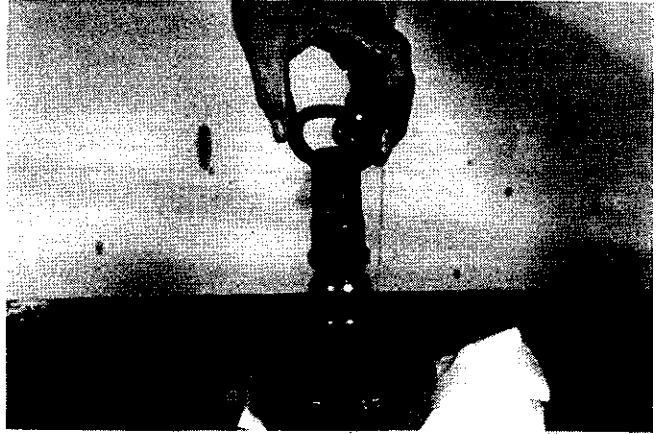

Assembly - JS 200LC (cont'd)

29. Remove blanks from inlet and outlet ports. Using clean hydraulic fluid, apply a pressure of 20 kg/cm² (284 lb. in²) to the brake release port (remember that hydraulic fluid will be discharged from the drain port). Check that the drive shaft can be rotated for at least one revolution by applying a torque of 4.88 to 9.76 Nm (3.6 to 7.2 lbf. ft.). If the shaft does not turn, the unit has not been assembled correctly and must be dismantled and inspected before re-assembly.

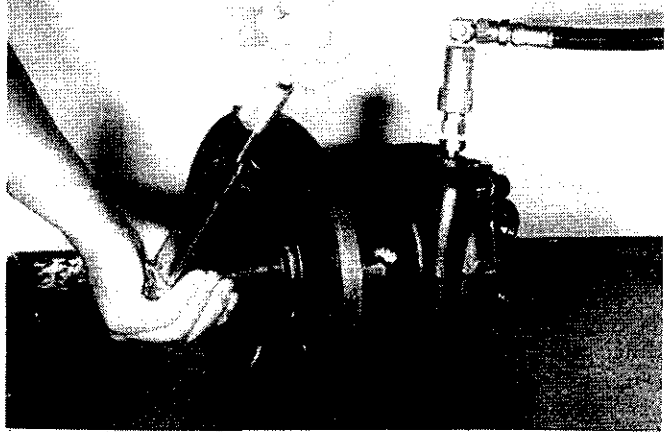

30. Degrease the mating faces of both motor 24 and reduction gearbox 56 sections. Apply JCB Hi-Strength Gasket to the mating face of the reduction gearbox section 56.

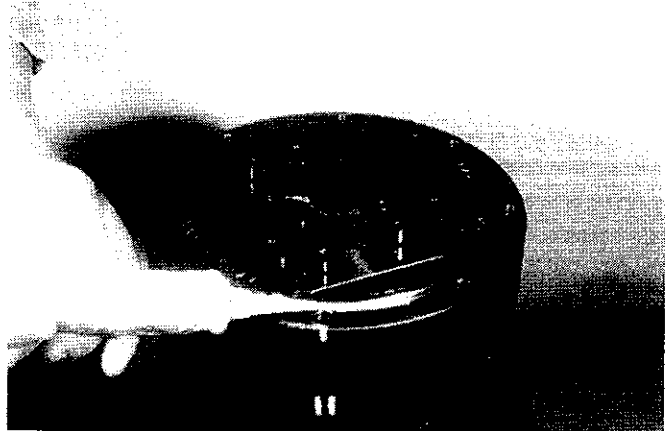

31. Fit the motor section 24 to the gearbox section 56, having lined up the alignment markings. Secure with bolts and torque tighten to 117.7 Nm (86.8 lbf. ft.).

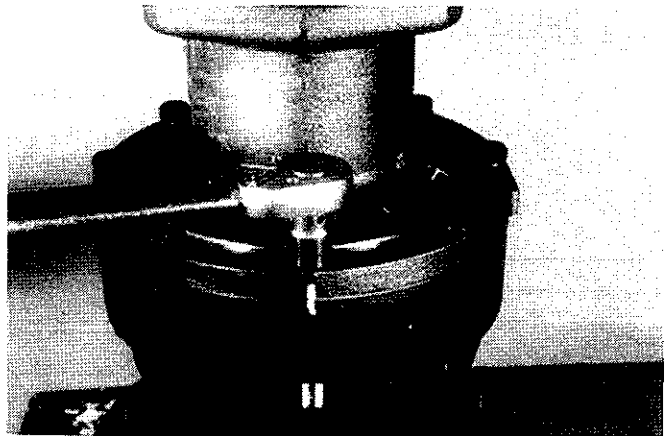

32. Fit dip stick tube 47 and dip stick. Fit drain plug A and torque tighten to 39.2 Nm (28.9 lbf. ft.). Fill the motor section with the recommended gear oil (see Section 3 for details of the oil and the filling technique). Apply the recommended grease to the reduction gearbox section (see Section 3 for details of the grease and the application technique).

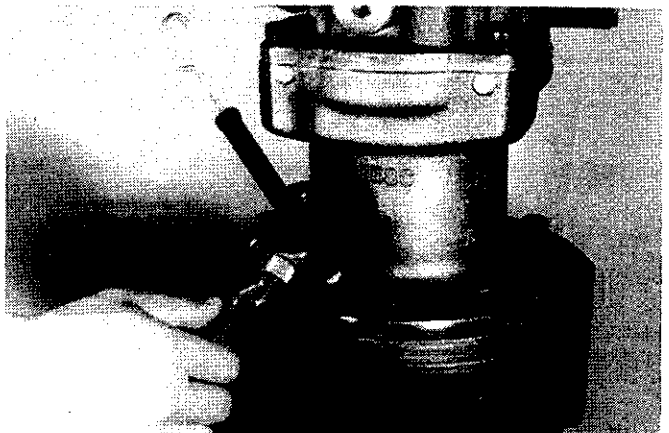

Dismantling - JS 200, 240, 300, 450LC

10. To dismantle a pressure reduction assembly, pull down the spring seat 216 (not more than 6mm (0.2in)) and remove the two semicircular washers 215, with a small screwdriver.

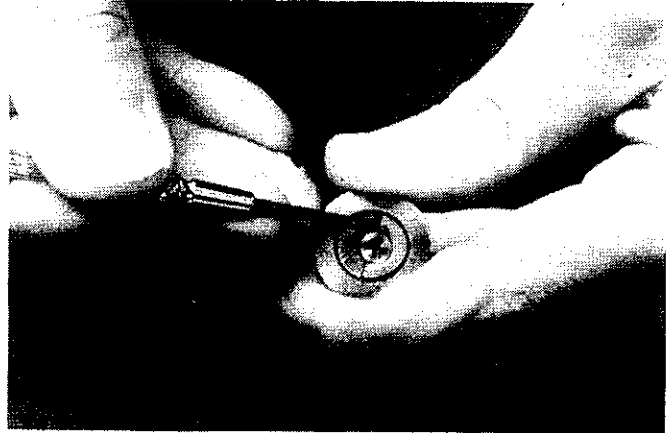

11. Separate the spool 201, spring seat 216, spring 241 and washer 217.

Keep the parts of each assembly together.

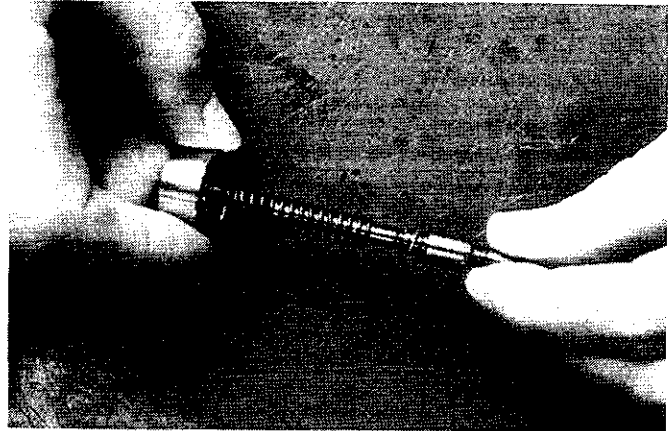

12. Remove the push rod 212 from the plug 211.

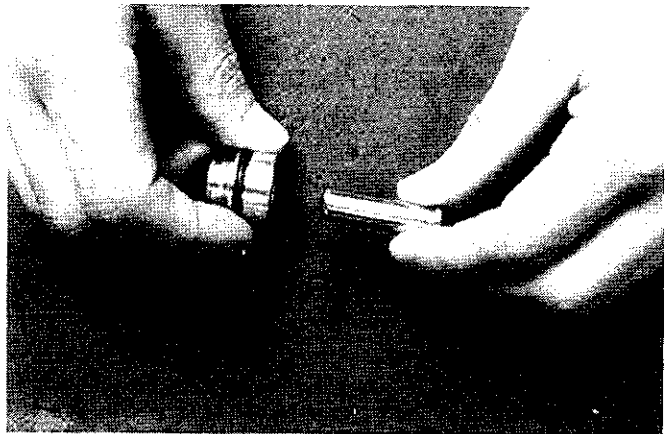

13. Remove the O-ring 214 and the seal 213 from the plug 211.



Hook Spanners

Cylinder Bore Diameter		Spanner Size		Cylinder Bore Diameter		Spanner Size	
mm	Ins	mm	Ins	mm	Ins	mm	Ins
120	4.72	140	5.51	150	5.91	170	6.69
125	4.92	145	5.71	160	6.30	180	7.09
130	5.12	150	5.91	170	6.69	190	7.48
140	5.51	160	6.30				

Torque Settings (JS200LC)

Item	Boom Ram		Dipper Ram		Bucket Ram	
	Nm	lbf ft	Nm	lbf ft	Nm	lbf ft
2	442 ± 82	326 ± 60	603 ± 112	448 ± 83	442 ± 82	326 ± 60
5	57 ± 10	42 ± 7	57 ± 10	42 ± 7	57 ± 10	42 ± 7
7	4590 ± 826	3386 ± 609	9425 ± 1697	6952 ± 1252	5140 ± 925	3791 ± 682

Torque Settings (JS240LC)

Item	Boom Ram		Dipper Ram		Bucket Ram	
	Nm	lbf ft	Nm	lbf ft	Nm	lbf ft
2	442 ± 82	326 ± 60	764 ± 143	564 ± 105	442 ± 82	326 ± 60
5	57 ± 10	42 ± 7	57 ± 10	42 ± 7	57 ± 10	42 ± 7
7	9100 ± 1690	6712 ± 1247	17700 ± 3330	13055 ± 2456	10740 ± 2010	7922 ± 1483

Torque Settings (JS300LC)

Item	Boom Ram		Dipper Ram		Bucket Ram	
	Nm	lbf ft	Nm	lbf ft	Nm	lbf ft
2	603 ± 113	448 ± 83	746 ± 144	564 ± 105	603 ± 113	448 ± 83
5	57 ± 10	42 ± 7	57 ± 10	42 ± 7	57 ± 10	42 ± 7
7	8700 ± 1566	6417 ± 1155	16900 ± 3042	12465 ± 2244	9330 ± 1679	6882 ± 1238

Torque Settings (JS450LC)

Item	Boom Ram		Dipper Ram		Bucket Ram	
	Nm	lbf ft	Nm	lbf ft	Nm	lbf ft
2	1216 ± 122	897 ± 90	1667 ± 166	1230 ± 122	1216 ± 122	897 ± 90
5	59 ± 6	44 ± 4	59 ± 6	44 ± 4	59 ± 6	44 ± 4
7	12750 ± 1275	9404 ± 940	19615 ± 1960	14468 ± 1447	12750 ± 1275	9404 ± 940

Removal (continued)

- 9 Remove the bolts and washers, then separate the gearbox from the undercarriage using a bar.

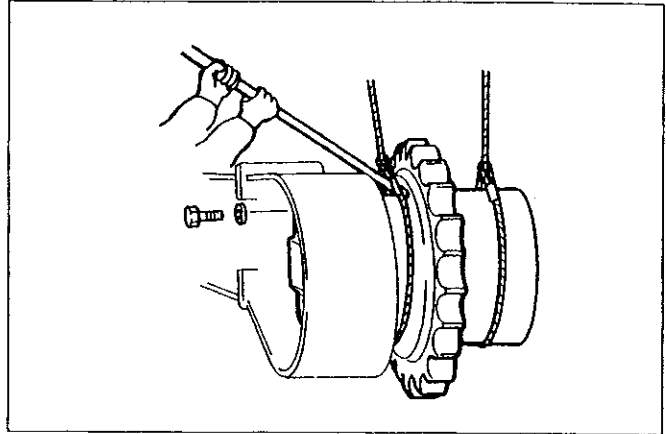
**Replacement**

- 1 Before fitting, clean the gearbox and bleed air out as follows:

Turn the gearbox so that the hydraulic oil ports are facing upwards.

Remove plugs from ports **A** and **B**. Fill the motor through port **A** with the specified hydraulic oil. Fit plugs to ports **A** and **B**.

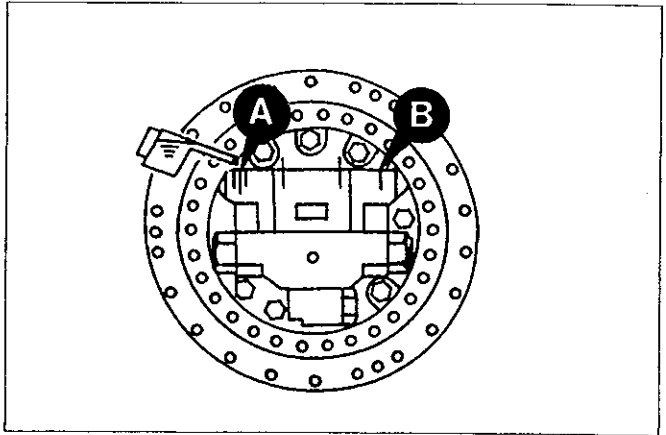

- 2 Lift the gearbox and position it on the undercarriage. Install the bolts and washers, using Loctite 262 on the bolt threads. Tighten the bolts in a diagonal sequence.

Torque Settings

JS200LC & JS240LC: 265-312 Nm (195-230 lbf ft),
JS300LC & JS450LC: 900-1050 Nm (665-775 lbf ft)

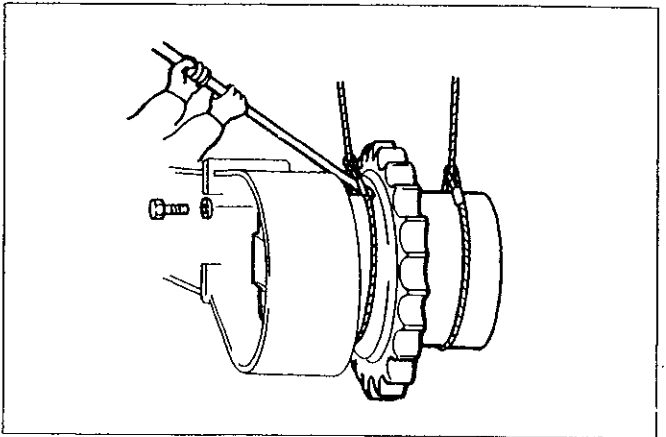

- 3 Remove plugs and install the hoses (travel and drain) to the motor.

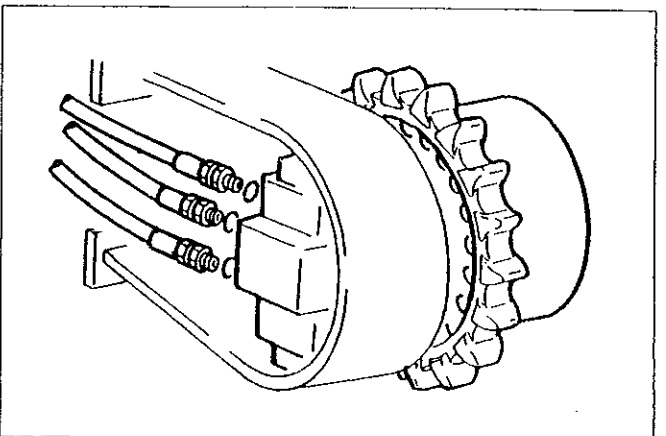

Dismantling - Motor Section - JS 200/300LC (continued)

16 Extract snap ring 14 and remove spring seat 15, spring 16 and collar 17.

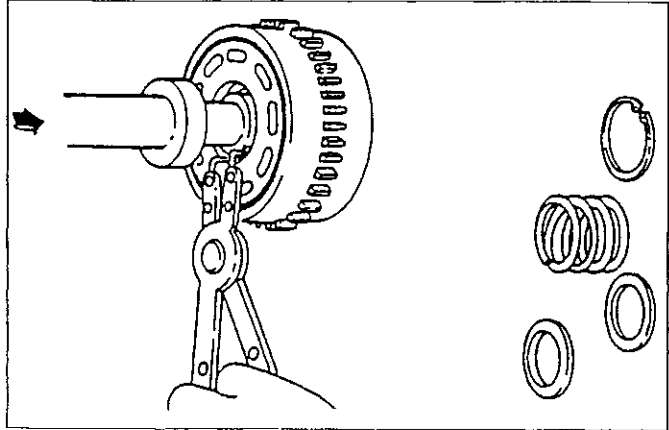

17 Remove shaft 3 from case 1.

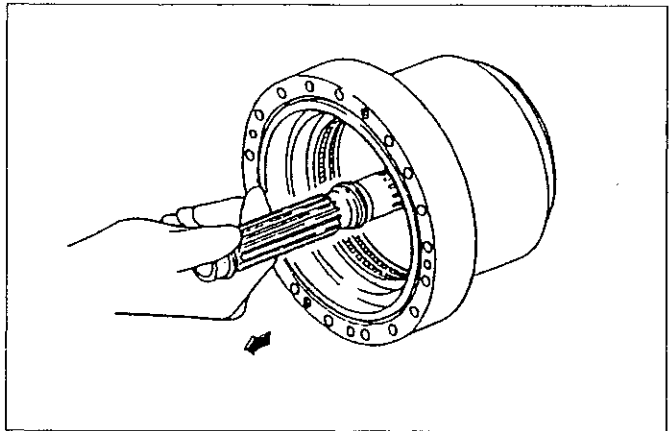

18 Carefully prise collar 26 from the case 1.

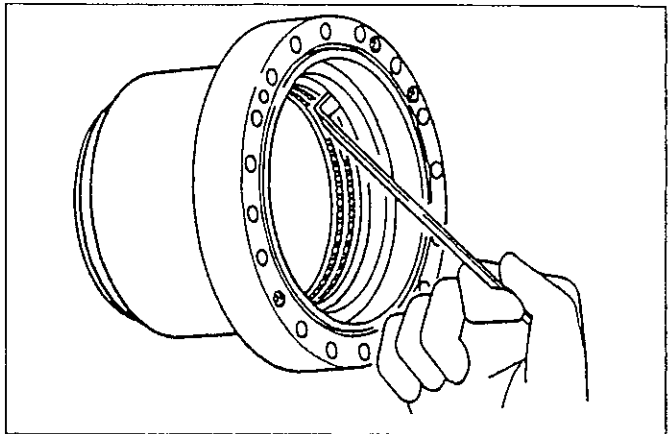

Dismantling - Reduction Gearbox - JS 200 (to Serial No 704597)/300LC (continued)

- 3 Remove the sun gear 6 and planetary gear holder 2.

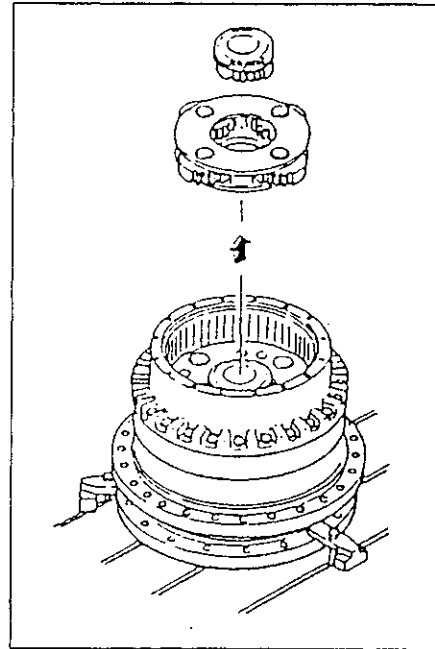

- 4 Fit 2 eye bolts to sockets for bolts 25 (see Step 1). Remove bolts 21 and lift off the ring gear 19 using the eye bolts and suitable lifting tackle. Remove pins 22 (3 off).

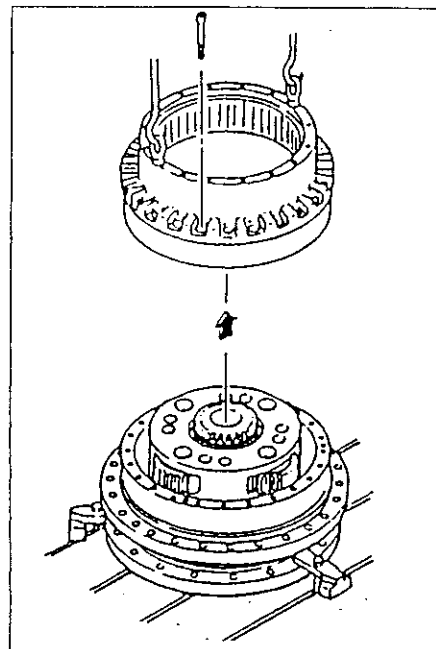

Assembly - Motor Section - JS 200/300LC (continued)

- 9 Press fit the inner race of the roller bearing 12 to the shaft 3 and fit to the case 1.

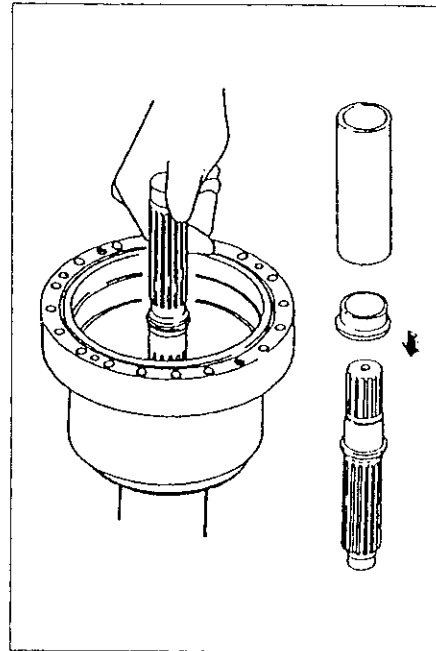

- 10 Fit springs 42 (2 off), pistons 11 (2 off) and steel balls 10 (2 off) to the case 1.

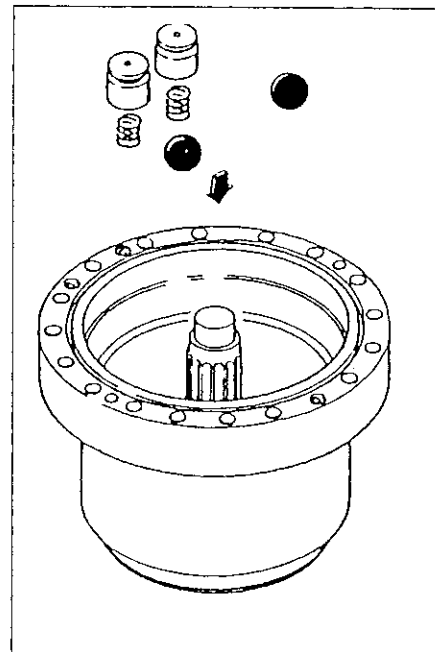

Assembly - Reduction Gearbox - JS 200 (to Serial No 704597)/300LC (continued)

- 9 Assemble the gear holder 1. Fit the needle bearing 1-3 (3 off) to the planetary gears 1-2 (3 off) and place the thrust washers 1-5 (6 off) on either side of the gear 1-2.

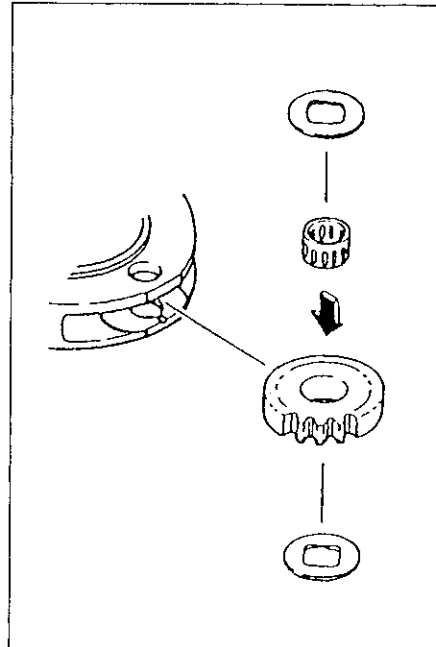

Fit the gear assemblies (3 off) to the holder 1-1 and fit the gear shafts 1-4. Take care to align the pin hole in the gear shaft 1-4 with the holes in the holder 1-1.

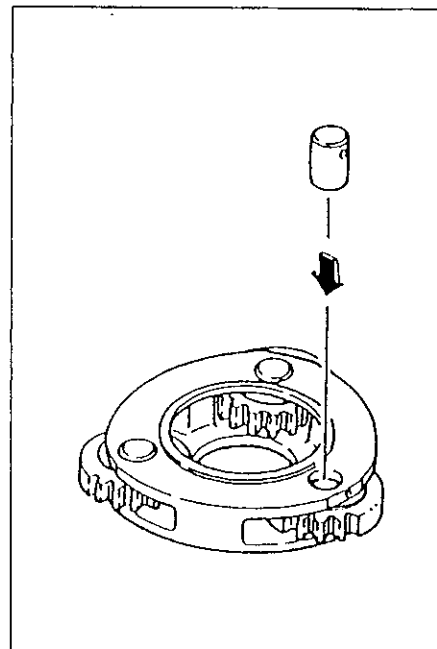

Assembly - Reduction Gearbox - JS 200 (to Serial No 704597)/300LC (continued)

- 24 Wrap the second plug 27 with sealing tape and fit to housing 13. Torque tighten to 9.8 - 14.8 Nm (7 - 11 lbf ft, 1 - 1.5 kgf m).

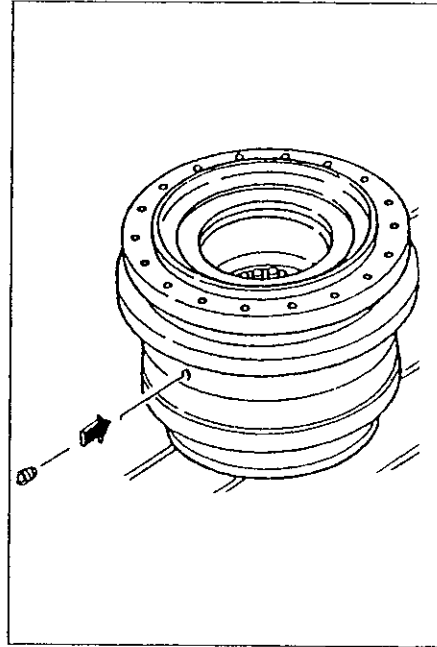

- 25 Fill with Lubricant (see Table of Lubricants).
Capacity JS 200/300LC - 8.5 litres (2.244 gals).

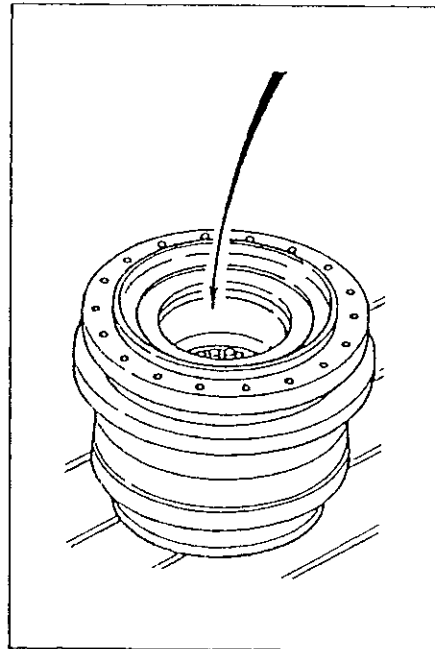

Dismantling - JS 240LC (continued)

- 29 Turn the gearbox through 90° and drain out any remaining oil.

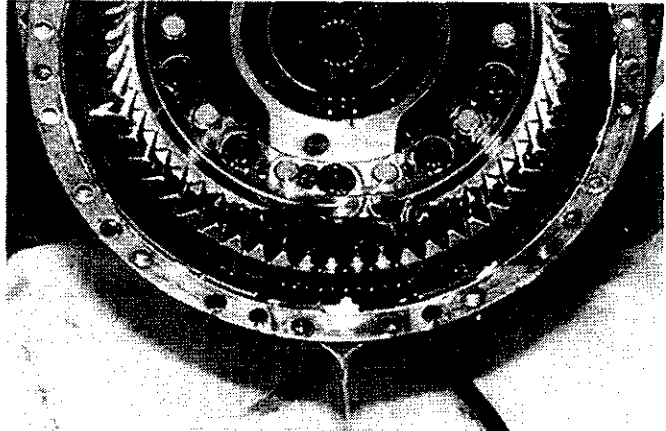

- 30 Scribe a match-mark across ring gear 86 and hub 71. Withdraw the ring gear using a pry-bar.

Remove ten pins 72 from the hub.

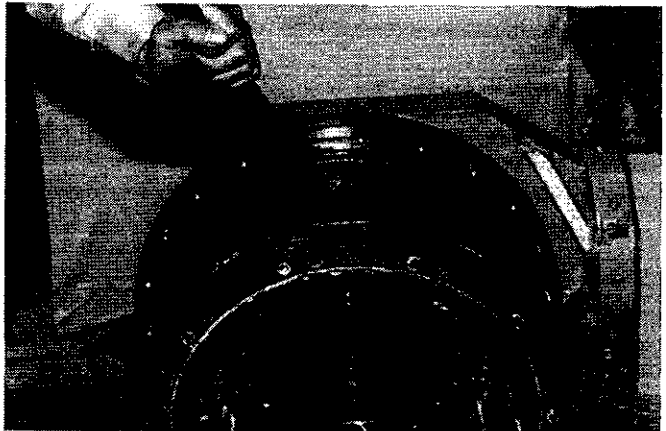

- 31 Scribe a match-mark across coupling gear 77 and housing 66. Remove ten bolts 78.

Note: Considerable torque will be needed to slacken these bolts as they are coated with locking fluid and tightened to a high torque load on assembly.



- 32 Install an eye-bolt into the M12 hole in hub 71 and suspend hub 71 to separate the hub from housing 66. This action will also separate bearings 70 and 73, seal ring 68, 'O' ring 69, coupling gear 77, ring gear 79 and distance piece 74.

Note: If suspending hub 71 will not separate these parts, turn the unit over so that the housing points upwards and hammer on the face of the hub as shown. In this case, parts will drop from the assembly, therefore a rubber mat or similar protective material should be placed on the floor to protect the parts from damage.

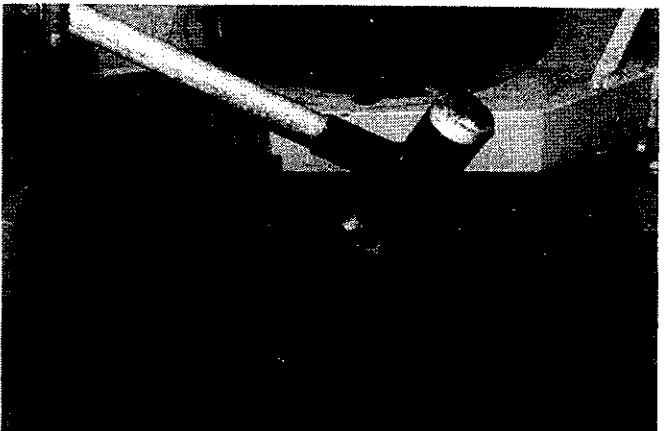

Assembly - JS 240LC (continued)

- 29 Lower the rear flange 1-1 onto housing 66, ensuring that dowel holes are aligned with dowels 15.

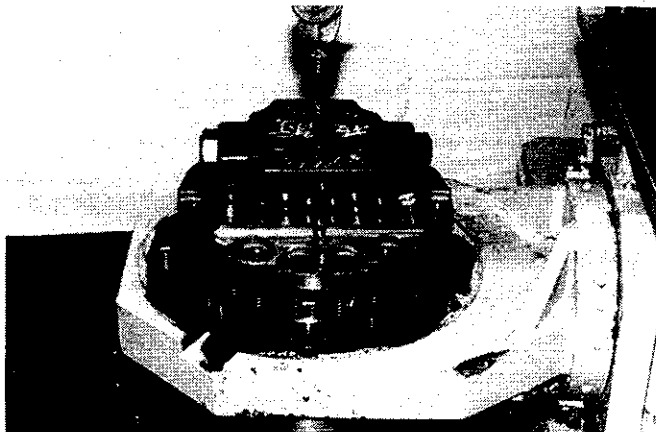

- 30 To make sure that the rear flange 1-1 is seated correctly, screw in four equally spaced bolts 18 and tighten them evenly in a diagonal sequence. Then fit the remaining bolts and tighten all the bolts to 215-290 Nm (160-215 lbf ft).



- 31 Fit a new 'O' ring 8 to each plug 9. Grease the springs 7 and valves 6. Install valves, springs and plugs into rear flange 1-1. Tighten plugs to 215-295 Nm (160-215 lbf ft).



- 32 Lightly grease 'O' rings 10 and 11 and position them on the rear flange 1-1.

Fit valve assembly 12 and tighten bolts 12-21 to 25-35 Nm (18-25 lbf ft).

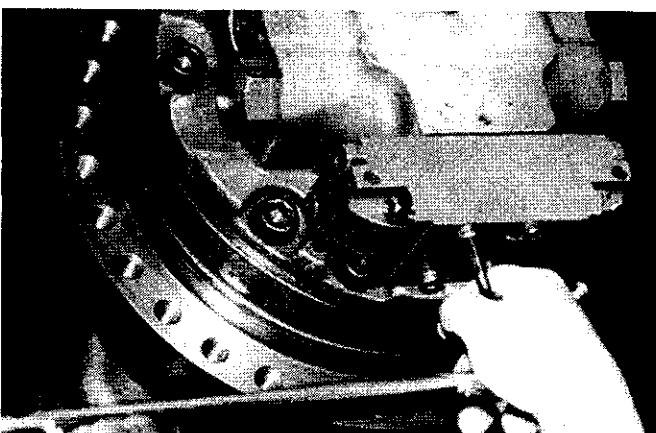

Assembly - Reduction Gearbox - JS 450LC (continued)

- 7 Knock in the spindle retaining pins until the ends are flush with the edge of the carrier plate.

Using a centre punch both sides of the pins, burr over the carrier plate surface to prevent the pins coming out.



- 8 Fit a new Teflon thrust washer with the oil grooves uppermost.

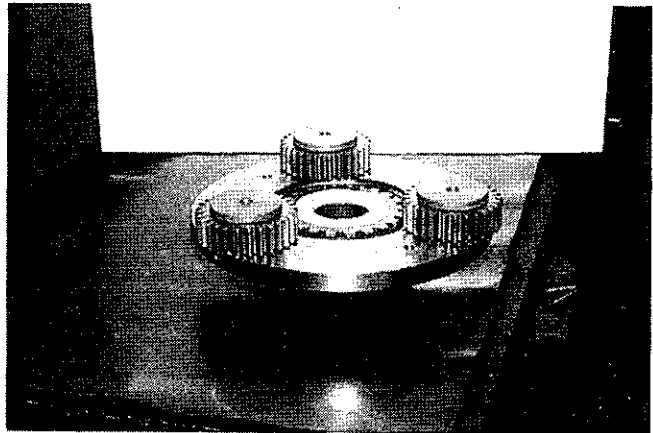

- 9 Coat the floating seal with a film of grease and install on the ring gear, pressing down with the finger tips.

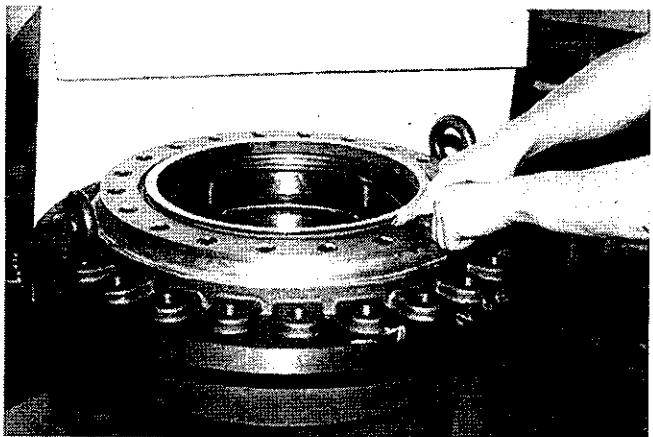

Assembly - Reduction Gearbox - JS 450LC (continued)

- 37 Install the hub cover and firmly tighten the mounting screws evenly and progressively.

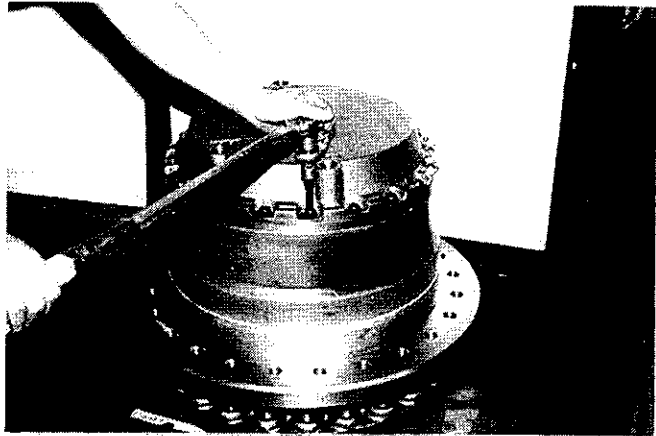

Dismantling - JS 300LC

Note: Do not stand the unit on the drive shaft as it would be unstable. Use a support which has a hole through which the shaft can protrude, thus allowing the unit to stand on its mounting flange. Before starting dismantling, drain the oil (see Section 3) and remove the Swing Motor (see Section E).

The numbers printed in bold type (e. g. 17) refer to the items on the illustration on page 24-1.

- 1 Remove No. 1 sun gear 17.

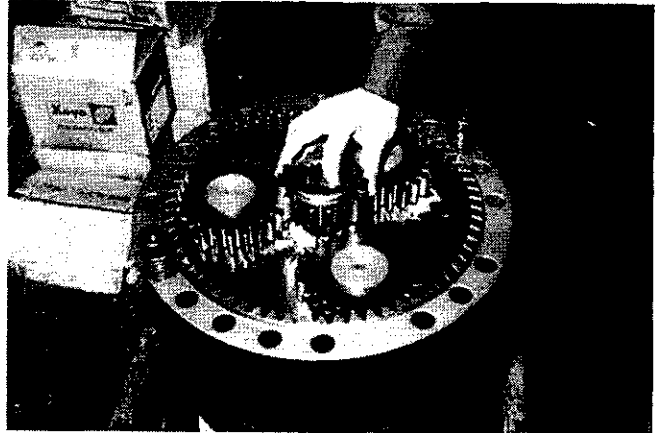

- 2 Screw two M12 eye-bolts into the tapped holes and remove No. 1 planet carrier 24 complete with gears.

Note: Do not remove the planet pins 19 unless necessary for renewal. To allow pin removal, carefully drill out the roll pins 23.

Press out planet pins 19 and remove washers 20, needle bearings 21 and gears 22.

Mark each planet gear and its pivot pin. Keep them in sets to assist assembly in their original positions.

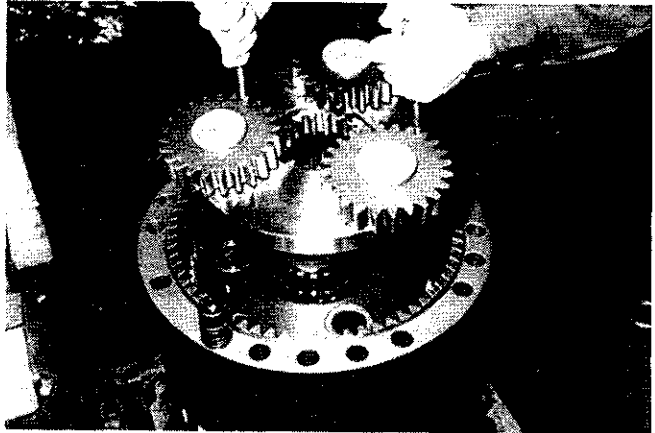

- 3 Remove No. 2 sun gear 14.

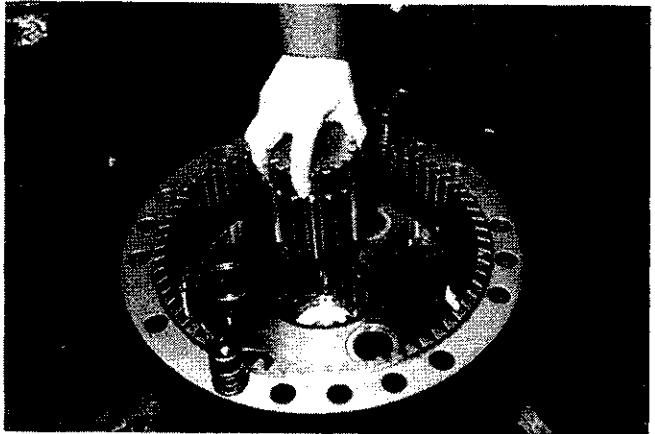

- 4 Remove upper thrust plate 12.

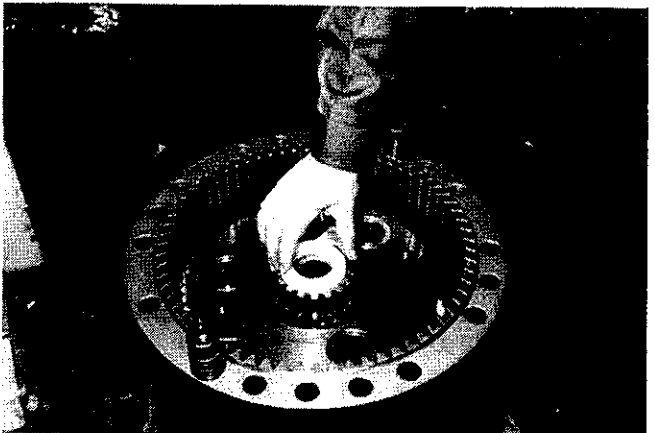

Assembly - JS 300LC (continued)

24 Fit planet gears 22.

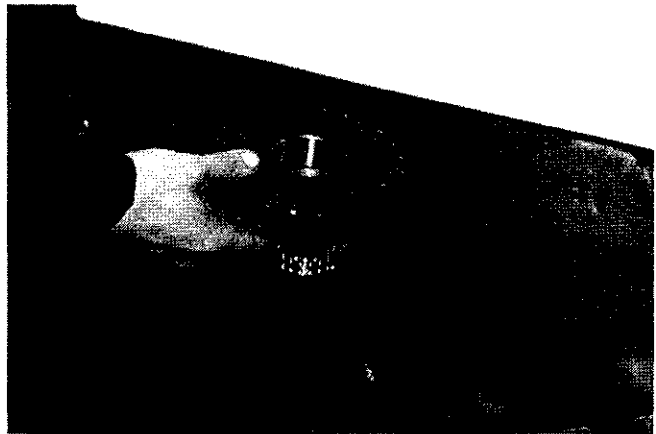

25 Fit lower washers 20.

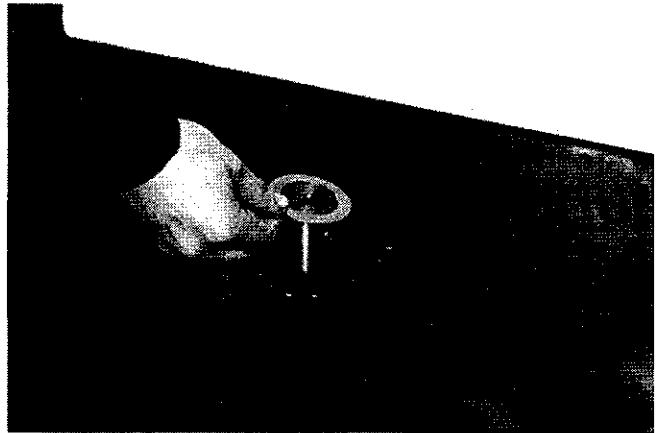

26 Press in planet pins 19 ensuring that the oil hole is facing outwards and the holes for the roll pin 23 are accurately aligned. Check that the planet gears turn smoothly.

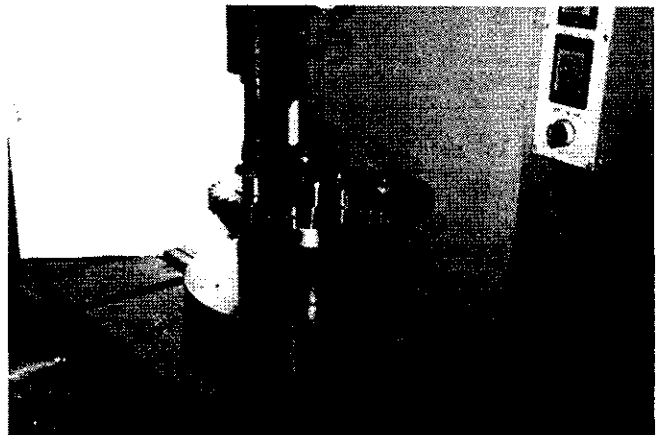

27 Drive in each roll pin 23 with the split in the pin facing towards the gear.

Note: The drilling for the roll pin is much longer than the pin. Drive in the pin just far enough to engage half its length in the planet pin and the other half in the planet carrier.

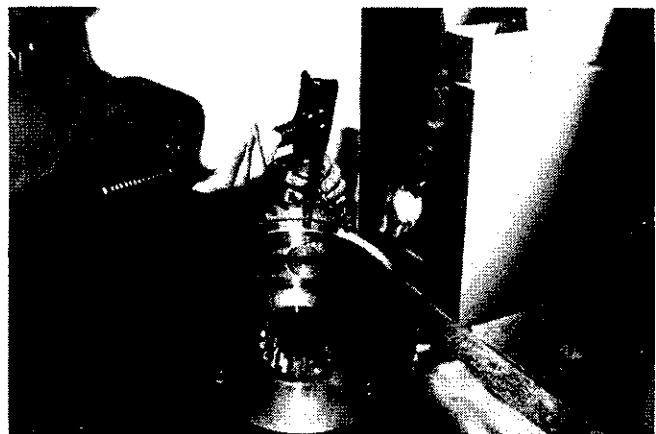

Assembly - JS 450LC

Before assembly all parts should be thoroughly cleaned using a suitable solvent. Remove all traces of gasket and thread locking compounds.

- 1 On the upper planet gear carrier, position the gears in the locations from which they were removed. Position the planet gear spindles so that their retaining pin holes align with the holes in the carrier plate and then use a press of 5 - 7 tonnes capacity to install them.

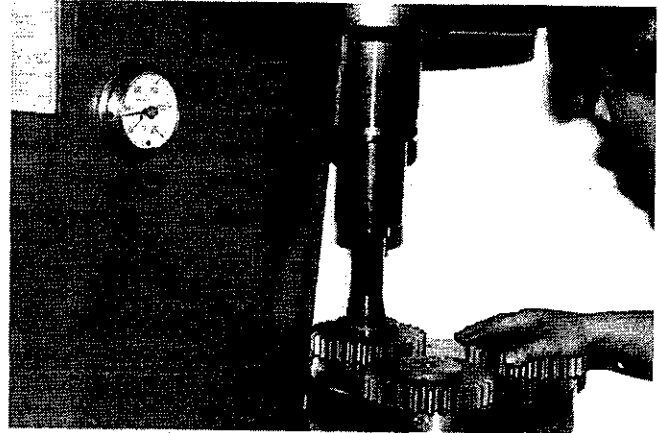

- 2 Knock in new spindle retaining pins. To prevent the pins coming out use a centre punch to burr over the metal either side of the pin aperture as shown below (arrowed).

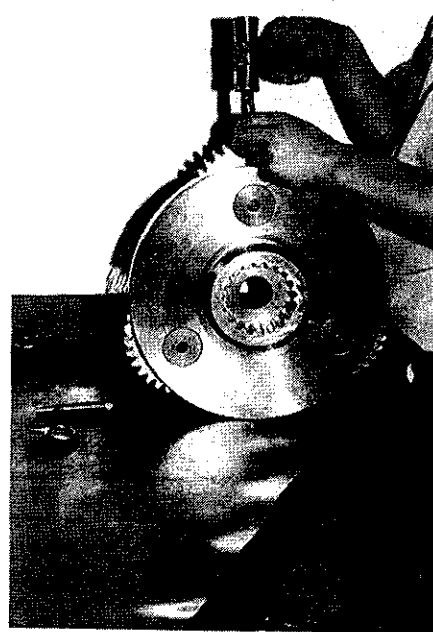
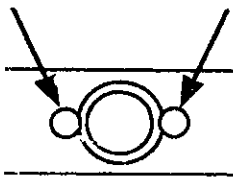

Contents	Page No.
Idler Wheel and Recoil Unit	
Removal	2 - 1
Replacement	2 - 2
Idler Wheel	
Dismantling	3 - 1
Assembly	3 - 2
Wear Limits	4 - 1
Grease Cylinder	
Removal	5 - 1
Replacement	5 - 2
Dismantling	6 - 1
Assembly	6 - 1
Drive Sprocket	
Removal	7 - 1
Replacement	7 - 2
Wear Limits	8 - 1
Top Roller	
Removal	9 - 1
Replacement	9 - 2
Dismantling	10 - 1
Assembly	10 - 2
Wear Limits	11 - 1
Bottom Roller	
Removal	15 - 1
Replacement	15 - 2
Dismantling	16 - 1
Assembly	16 - 2
Wear Limits	
- JS200LC & JS300LC	17 - 1
- JS240LC & JS450LC	17 - 2

Removal (continued)

- 5 Remove the bottom roller (third from front).

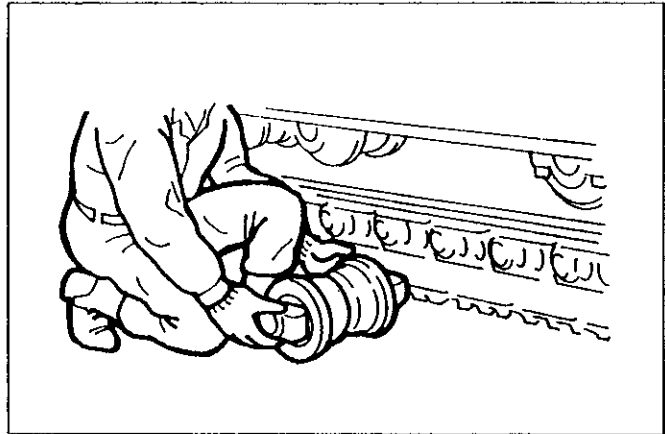

- 6 Remove the bolts, then take out the grease cylinder from the track frame.

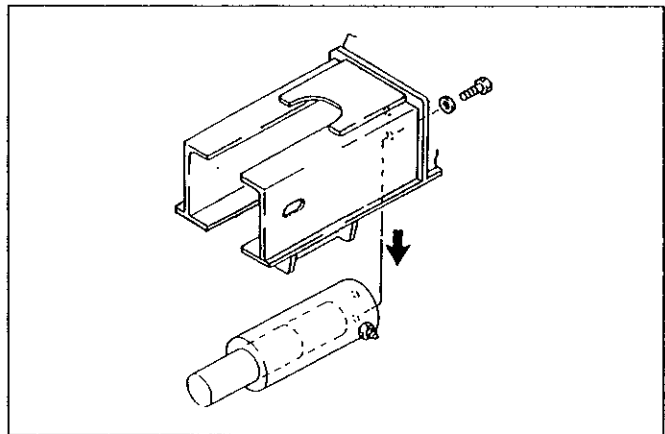
**Replacement**

- 1 With the undercarriage lifted and supported as shown under **Removal**, install the grease cylinder into the track frame.

Fit the mounting bolts and tighten to 264-303 Nm (195-224 lbf ft).

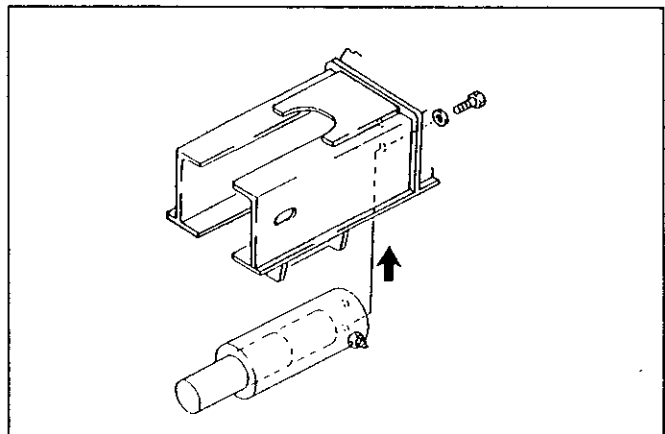

- 2 Position the roller on the track link as shown.

Align the holes in the brackets with the tapped holes in the undercarriage.

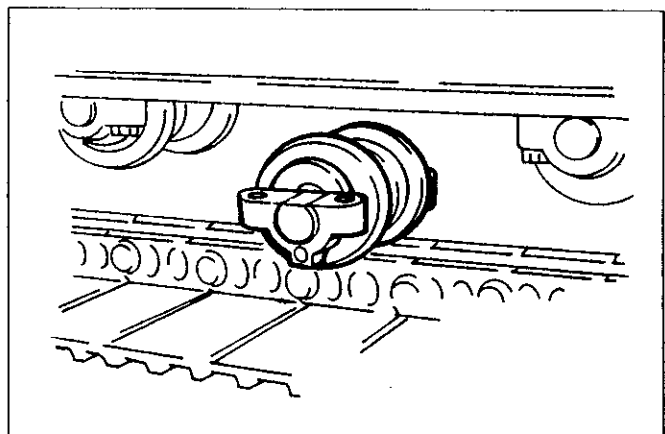

Dismantling (continued)

5 Remove seal 4 from roller 1 using a pry bar.

Note: Some rollers are fitted with two roll pins Z.

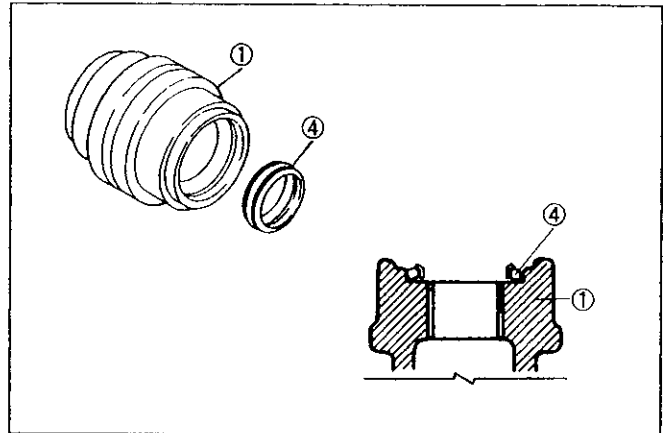
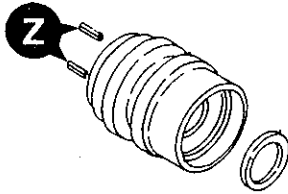

6 If badly worn or damaged, remove the bushes 3 from roller 1 using a press or puller.

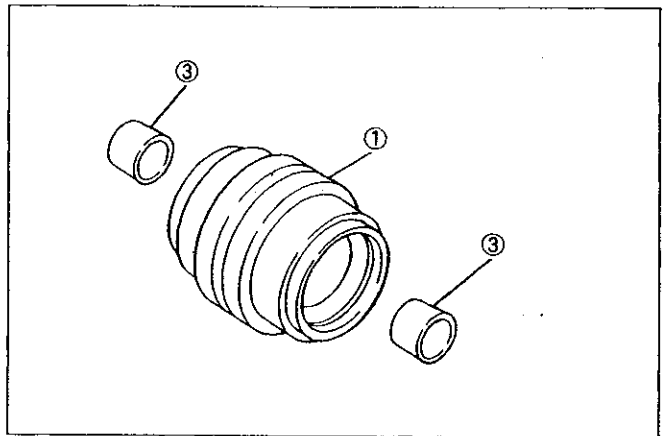

7 Remove seal 4 from bracket 5 using a pry bar.

Protect parts from moisture and dust if left dismantled for some time.

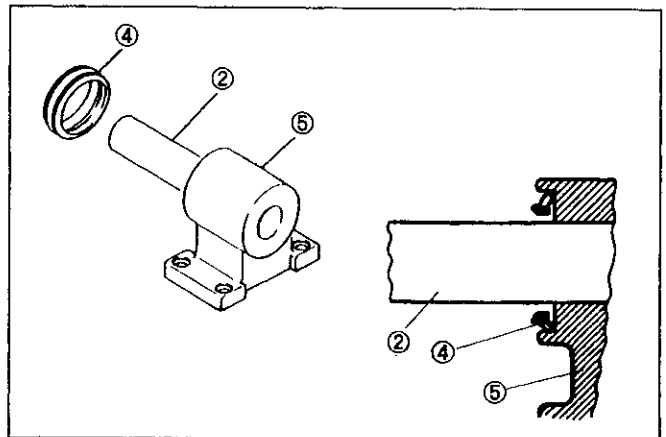
**Assembly**

1 Clean all parts thoroughly in a suitable solvent. Dry shaft and bore of roller using compressed air in a place free of dust and moisture.

Check components for wear as detailed under **Wear Limits**. Polish out scratches and roughness using an oil stone. Then apply a coat of engine oil to all parts.

If a new shaft or bracket are required, press-fit shaft 2 into bracket 5, taking care to protect the threads of the tapped holes in the end of the shaft.

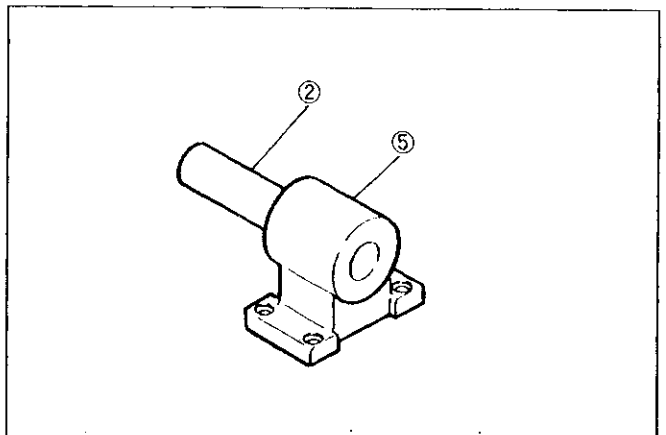

CLICK HERE TO **DOWNLOAD** THE COMPLETE MANUAL

- Thank you very much for reading the preview of the manual.
- You can download the complete manual from: www.heydownloads.com by clicking the link below



- Please note: If there is no response to CLICKING the link, please download this PDF first and then click on it.

CLICK HERE TO **DOWNLOAD** THE COMPLETE MANUAL