

SUMMARY

GENERALITIES	SECT. 0
ENGINE	SECT. 1
TRANSMISSION	SECT. 2
FINAL DRIVES	SECT. 3
STEERING CLUTCHES - BRAKES	SECT. 4
UNDERCARRIAGE	SECT. 5
DOZER EQUIPMENT	SECT. 6
HYDRAULIC SYSTEM	
ELECTRICAL SYSTEM	SECT. 7

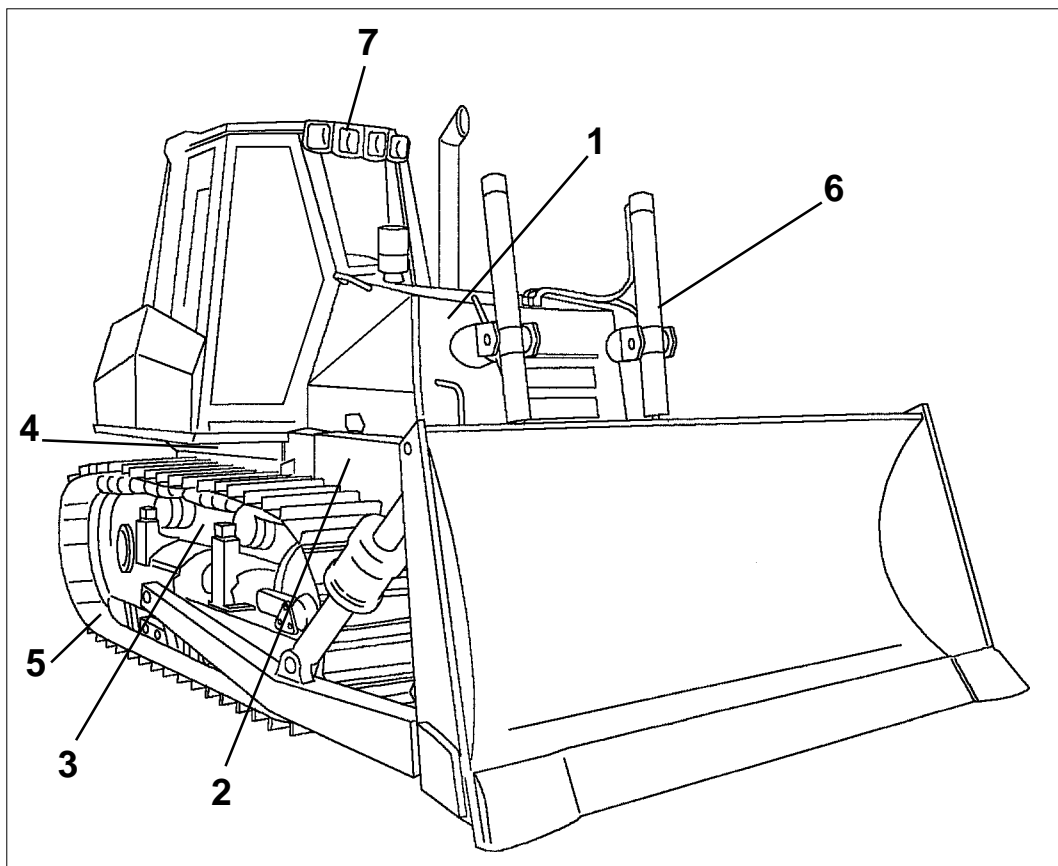

CLICK HERE TO **DOWNLOAD** THE COMPLETE MANUAL

- Thank you very much for reading the preview of the manual.
- You can download the complete manual from: www.heydownloads.com by clicking the link below



- Please note: If there is no response to CLICKING the link, please download this PDF first and then click on it.

CLICK HERE TO **DOWNLOAD** THE COMPLETE MANUAL

D180

DOZER

TECHNICAL DATA TABLES

TIMES OF EQUIPMENT MANOEUVRES

		TIME (sec.) MIN SPEED	TIME (sec.) MAX SPEED
	BLADE RAISING		
1	From ground level to max. height	6.7	3.2
2	From max. depth to max. height	10.5	4.6
	BLADE LOWERING		
3	From max. height to ground level in power down	1.5	1.6
4	From max. height to max. depth in power down	2.3	2.4
5	From max. height to ground level in float	1.6	1.7
6	From max. height to max. depth in float	2.3	2.3
7	Delay for lifting of machine with blade	3.2	0.8
	TILT		
8	R.h. of blade from min. to max. height	2.8	2.7
9	R.h. of blade from max. to min. height	2.1	2.0
	RAISING OF RIPPER		
12	From ground level to max. height	3.8	1.7
13	From max. depth to max. height	6.9	3.1
	LOWERING OF RIPPER		
14	From max. height to ground level	1.8	1.1
15	From max. height to max. depth	2.9	2.2
16	Delay for lifting of machine with ripper	0.8	0

Index no. of material (f)	Class of strength and type of material					
	FIAT	UNI	DIN	SAE	BSI	BNA
0	R 40	D - 4S - 4A		1	A	42
1	R 50	5S - 6S		3	P	56
2	R 80	8G		5	T	80
3	R 100	100	10K	8	V	100
4	Ottone	Ottone	Messing	Brass	Brass	Laiton
5	Alluminio	Alluminio	Aluminium	Aluminium	Aluminium	Aluminium
6	Rame	Rame	Kupfer	Copper	Copper	Cuivre
7	Free from other metal materials					

NOTICES

- Lubricate with engine oil the fixtures up to diameter 24, with tallow for larger diameters.
- The tolerance on tightening torques is $\pm 5\%$.
- The strength classes R80, R100, R120, must be intended as follows:

10.9 supersedes R 100
 12.9 " R 120

} for screws

10 supersedes R 80
 12 supersedes R 100

} for nuts

CDT=cadmium plated;FOSF=phosphatised;ZNT=zinc plated.

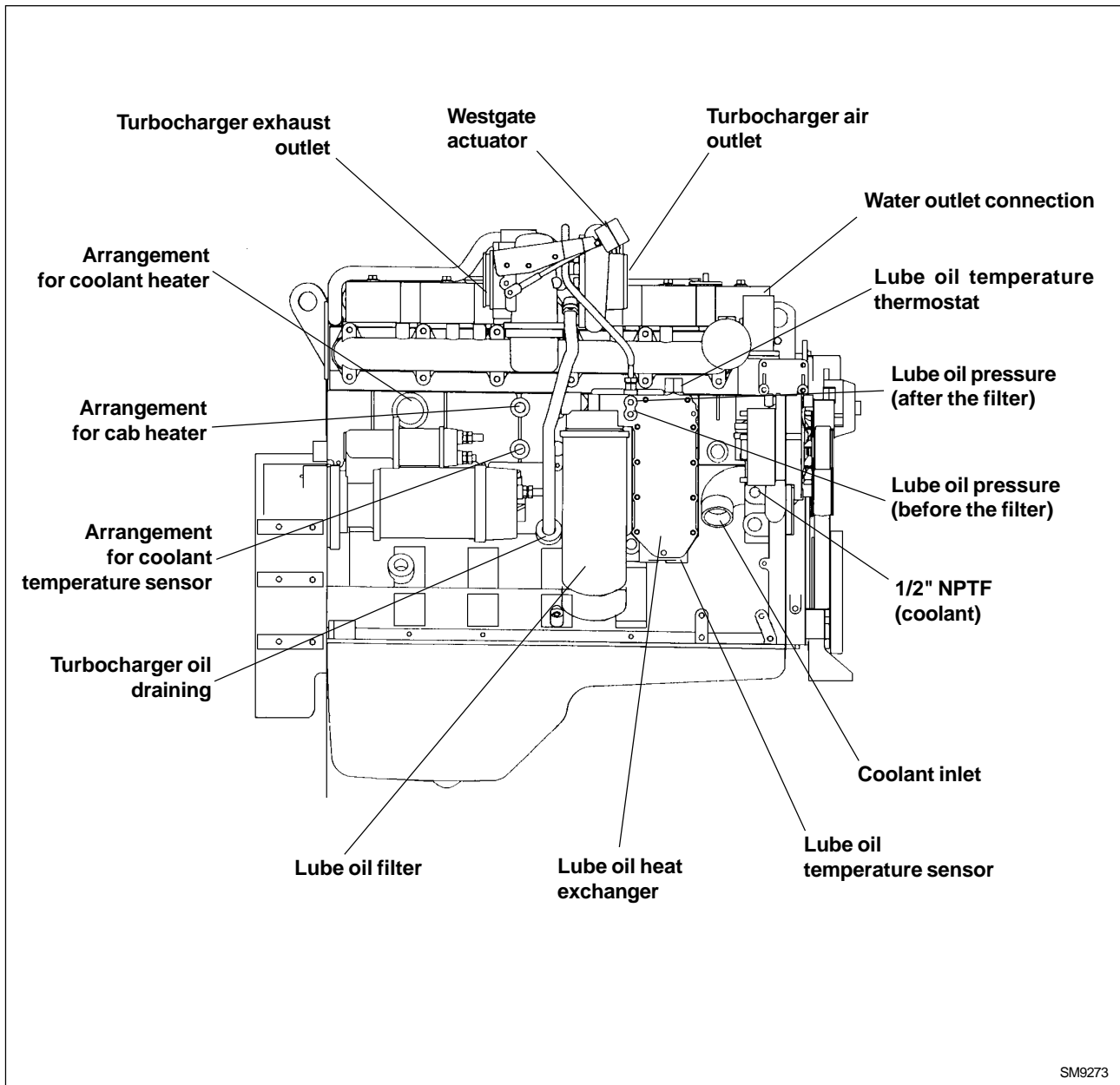

Fig. 1-11 View from turbocharger side

2.3 TESTS

2.3.1 Torque converter stall test

The stall test must be performed when the power group (engine and transmission) do not operate satisfactorily. The scope of the test is to determine if the transmission is defective. It is performed with the engine running at maximum speed and the transmission output stalled. Perform the torque converter stall test proceeding as follows:



WARNING

Do not run the engine of this machine in closed areas without proper ventilation to remove deadly exhaust gases.

Be sure exposed personnel in the area of operation are clear of the machine before moving it or its attachments. **WALK COMPLETELY AROUND** the machine before mounting. Sound horn. Obey flag man, safety signals and signs.

Comply with all procedures for the starting and stopping of the machine and the "NOTICES" listed in the Operation and Maintenance Manual.

1. Connect a precision revolution counter to the engine and bring the transmission housing to the operating temperature: **DO NOT PERFORM** this test with cold oil. Record the engine speed (rpm).

NOTE - The stall conditions must not be kept for over 30 seconds, in any case, to avoid excessive temperatures.

2. Block the transmission output shaft, keeping the brake pedal pressed, then engage the forward high speed range checking that the engine is at full speed. Record the engine speed. **DO NOT** let the temperature on the outlet of the torque converter exceed 120 °C (250 °F).

NOTE - Let the transmission operate in neutral for an interval of about 2 minutes between the various stall tests, to avoid overheating. During these two minutes do not let the engine speed drop, except when shifting through the neutral.

3. Engage the other speeds and check that the engine speeds drops the same value, independently from the speed being engaged. In the event the engine speed does not drop with a given speed engaged, it is probable that the relevant clutch slips. In the event the engine speed does not drop with all speeds, as indicated, this could be due to:
 - the transmission, if the shaft between torque converter and transmission is operating, or
 - the torque converter, if said shaft is inoperative

RESULT: Under stall test conditions, a comparison between the effective engine speed and the normal one prescribed for such conditions, indicates that the trouble is in the engine or in the transmission.

NOTE - Ambient conditions, such as ambient temperature, elevation, variations in the loss of engine accessories, influence the power transferred to the torque converter: These conditions can cause variations in the stall speed of 50 rpm, with respect to the normal value. When the difference can be assigned to such causes, the effective speed can be accepted as normal.

2.3.2 Delivery pressure test procedure

Prior to measuring the pressures and the oil flow of the torque converter and transmission, it is necessary to proceed with the following preliminary check.

Check the oil level of the transmission, with the oil at normal operating temperature: **DO NOT** perform this test with cold oil: To bring the oil temperature to the prescribed value, it is necessary to operate the machine or stall the converter.



WARNING

Keeping the stall speed too long, overheats the torque converter.

Do not run the engine of this machine in closed areas without proper ventilation to remove deadly exhaust gases.

Prior to starting the engine, warn all persons nearby the machine.

NEVER LEAVE THE MACHINE UNATTENDED with the engine running.

Check the temperature and pressure gauges on the instrument panel. If the main pressure stays within the limits (or in case the trouble persists after interventions to correct the main pressure) measure and record all pressures for a comparison.

The pressure gauge pick-up points of the pressures of the entire system are located on the control valve illustrated at page 2-12. All connections can be made simultaneously. The pressure gauge connected to each point must have a capacity sufficient to measure the pressure involved; however it must not be so high to make the reading of the correct pressure difficult.

Remove the bearing circlip from the equipment pump drive, and pull-out the spacer and the bearing from the shaft.

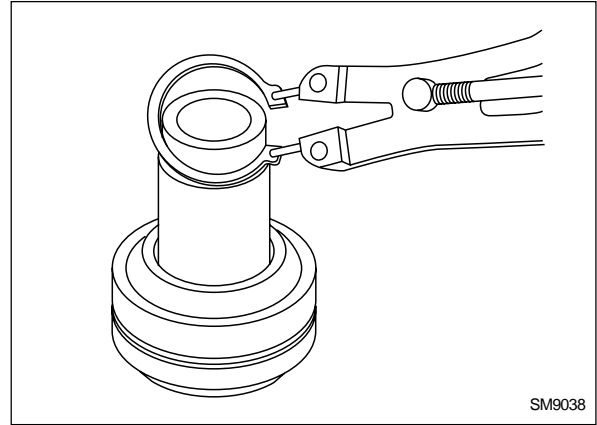

Place the equipment pump drive shaft on a vertical press of appropriate capacity to remove the inner race of the bearing from the shaft.

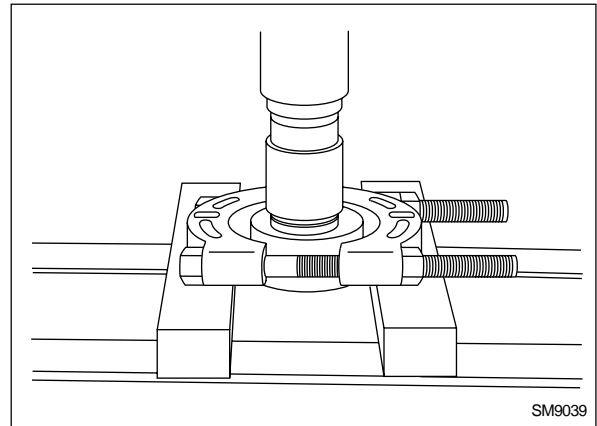

Place the torque converter assembly on an appropriate work bench.

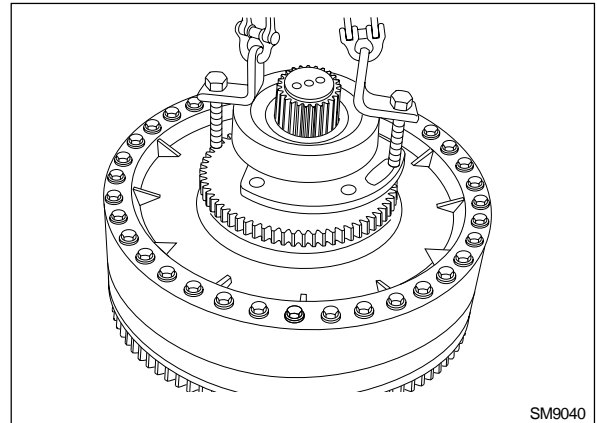

Remove the front bearing retaining plate.

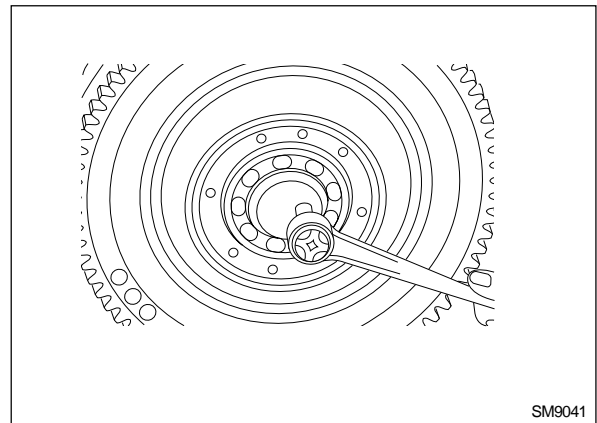

Remove the low and high range clutches distribution spools and pull them out from the shafts.

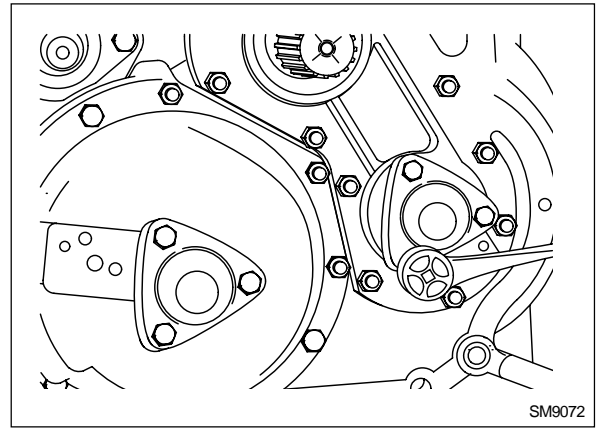

Remove the low range clutch housing cover.

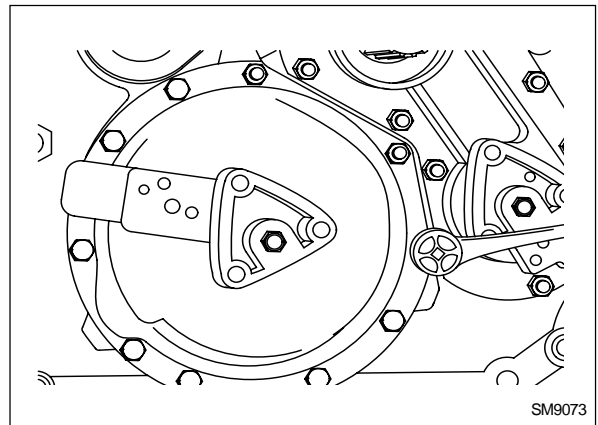

Remove the rear cover.

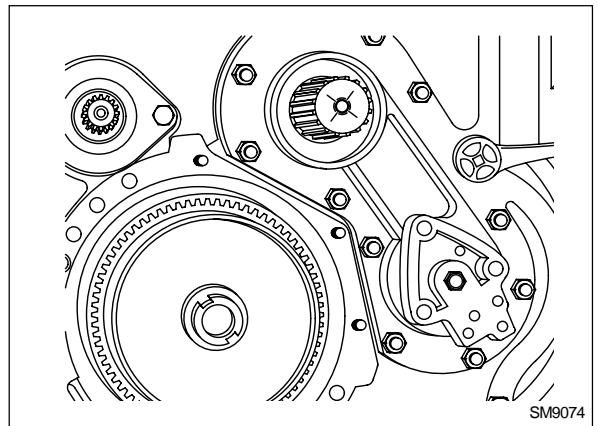

Remove the reverse clutch pipe holder.

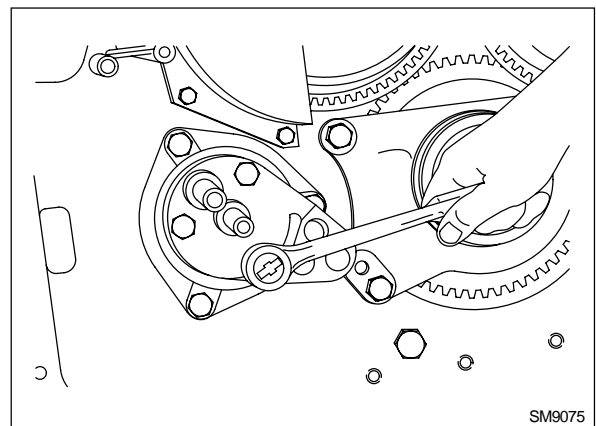

Install two clamps (P/N 75291531) on the reverse clutch.

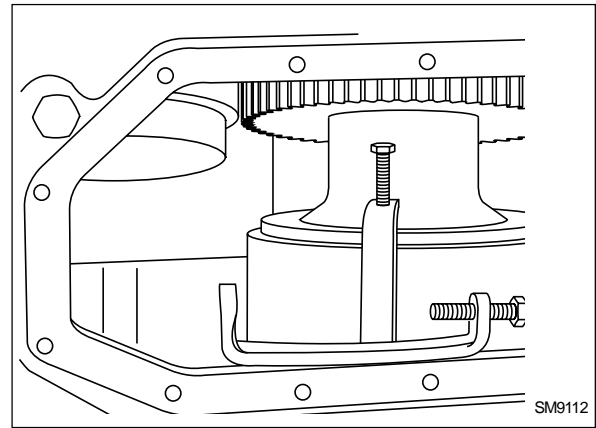

Loosen and remove the reverse clutch shaft locking nut.



WARNING

It is dangerous hitting hardened steel parts with tools different from hammers made of mild steel or non ferrous metals. When these components are remove or installed, always wear safety glasses with side shields, heavy gloves etc., to reduce the chances of injuries.

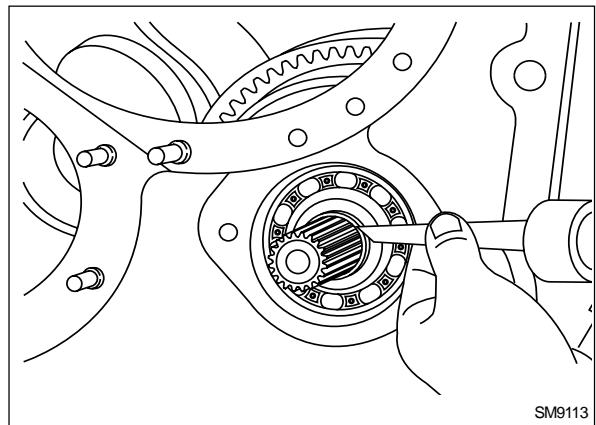

Pull-out the reverse shaft/PTO shaft through the clutch and the housing.

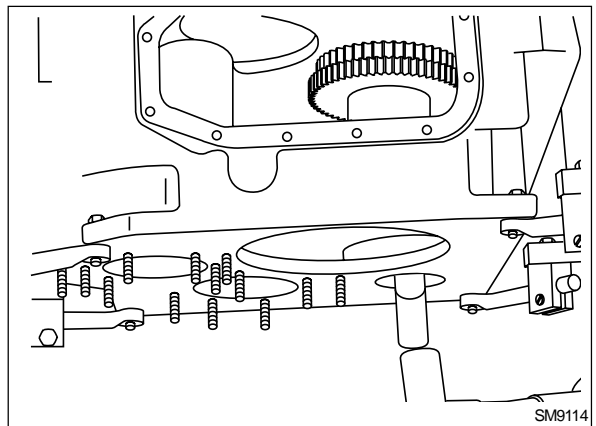

Remove the input gear and the reverse spacer.

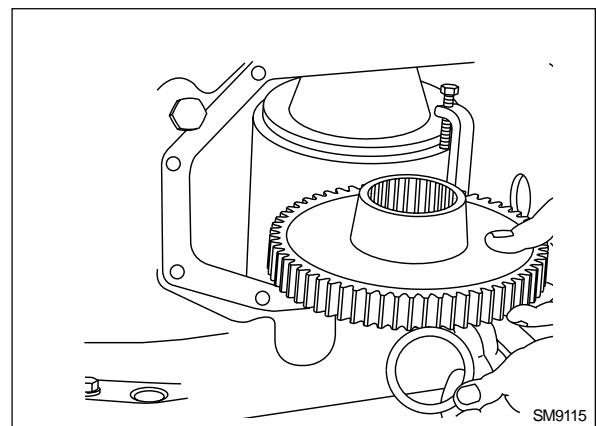

Pull-out the spring stop and the return spring from the hub; check that the spring complies with the prescribed requirements.

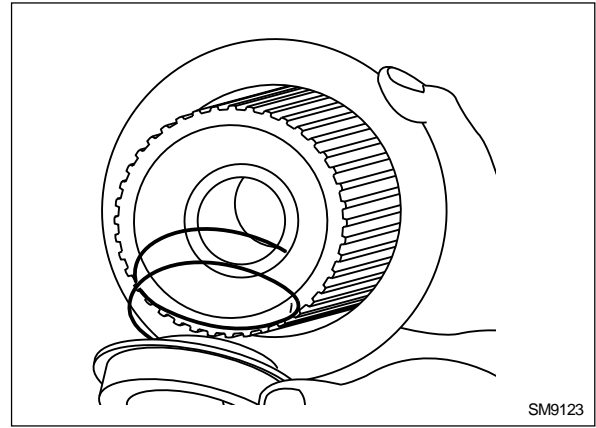

Insert the return spring and the relevant stop in the hub; press the stop and install the circlip.

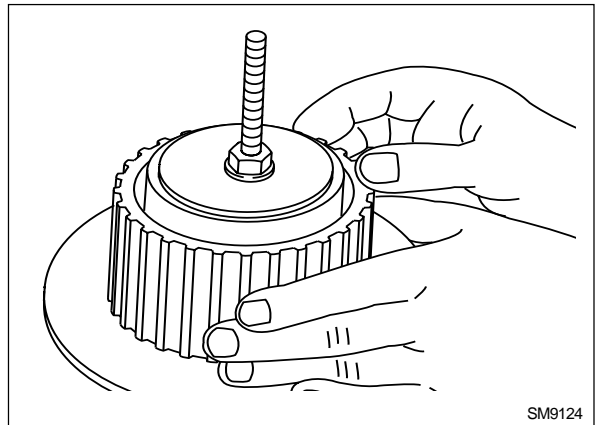

Install the friction discs, the spacer springs and the steel discs, alternatively, on the hub.

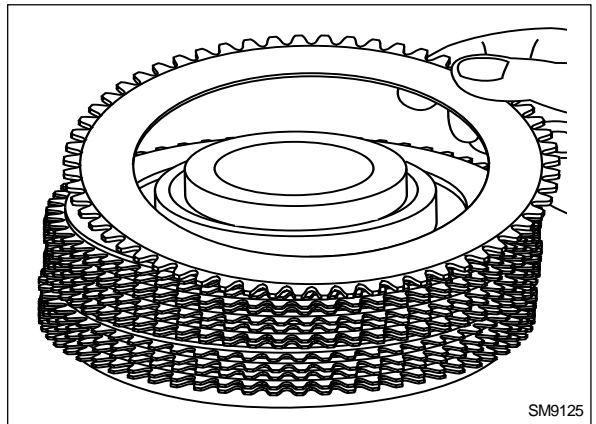

To measure the height of the clutch pack, place the clutch assembly on a press and load it at 197 daNm (1450 lbs), measuring as illustrated.

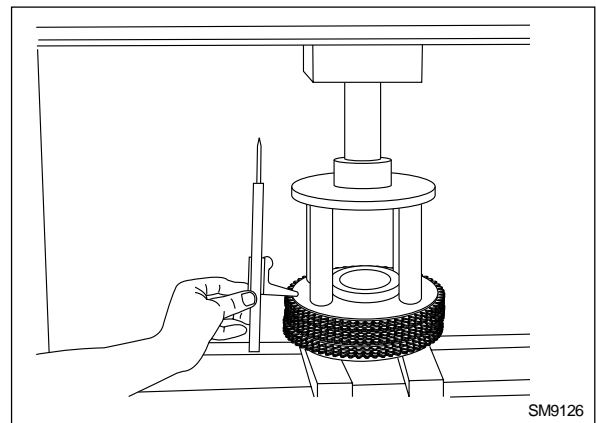

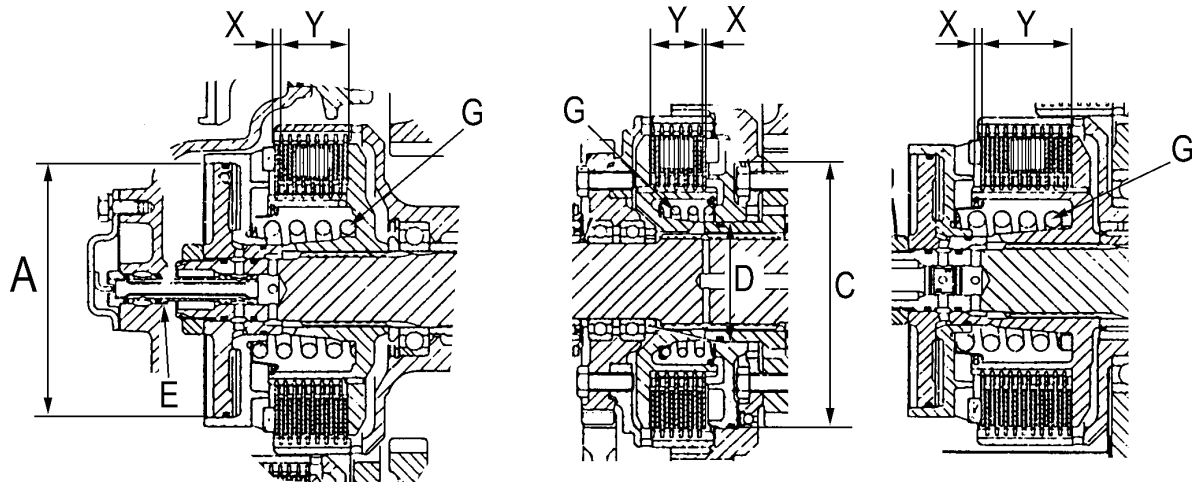

Fig. 10 Section 1st Speed
2nd Speed
REVERSE

Section 3rd Speed

Section FORWARD

SM9163

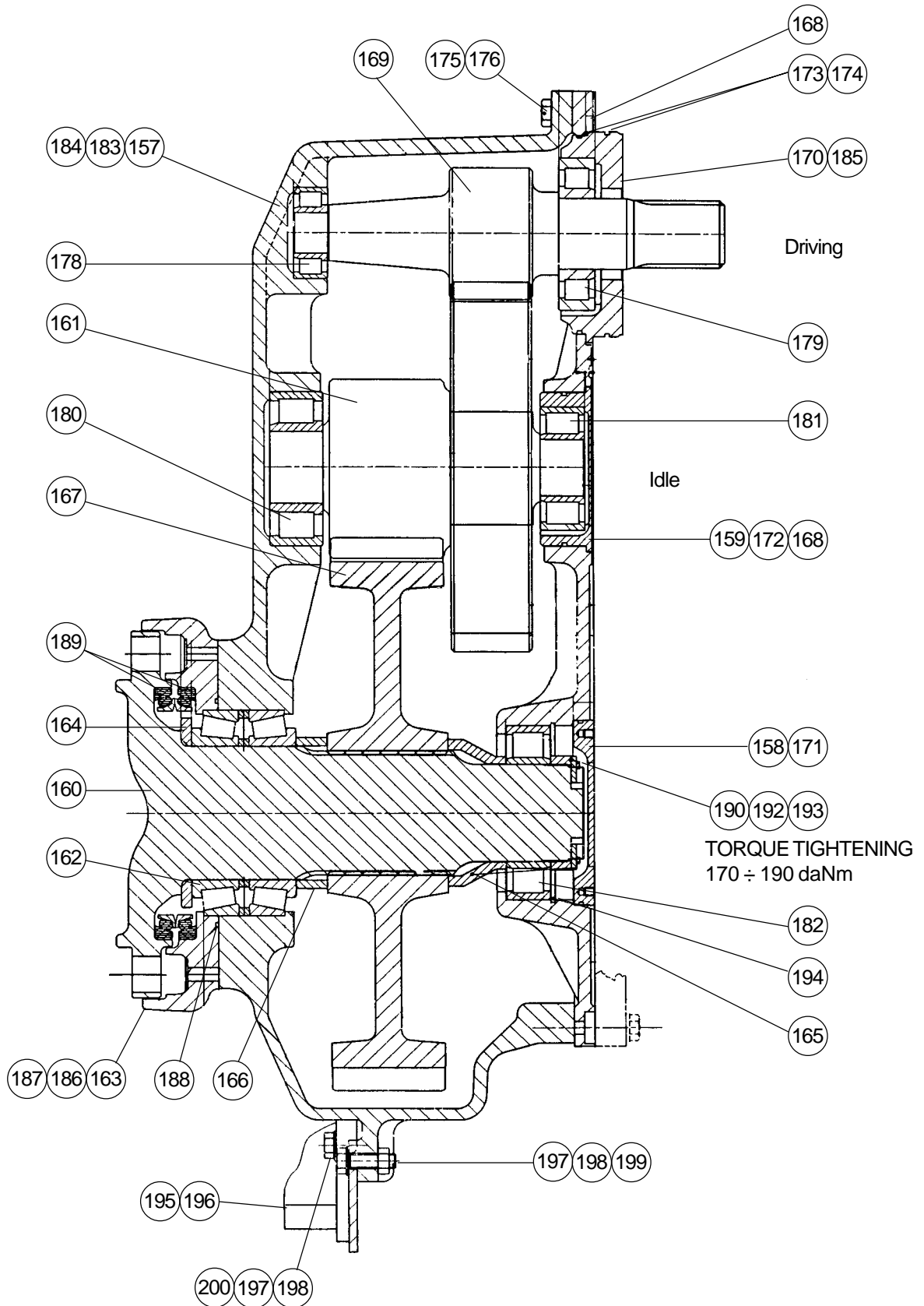

Fig. 3 - Final drive sectional view
(For the components, refer to fig. 2).

SM9000

CLICK HERE TO **DOWNLOAD** THE COMPLETE MANUAL

- Thank you very much for reading the preview of the manual.
- You can download the complete manual from: www.heydownloads.com by clicking the link below



- Please note: If there is no response to CLICKING the link, please download this PDF first and then click on it.

CLICK HERE TO **DOWNLOAD** THE COMPLETE MANUAL

Prepare bearing housing (159) of idle shaft (161) and install bearing (181) using a press.

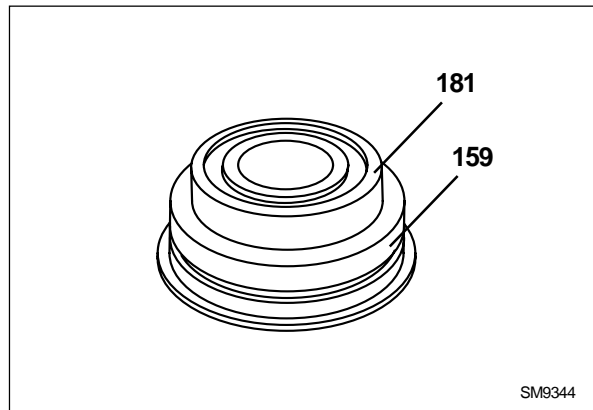

Fig. 35

Warm-up inner races (P) of bearings (179) of driving gear (169) at about $110 \div 120 \text{ }^\circ\text{C}$ ($230 \div 248 \text{ }^\circ\text{F}$).

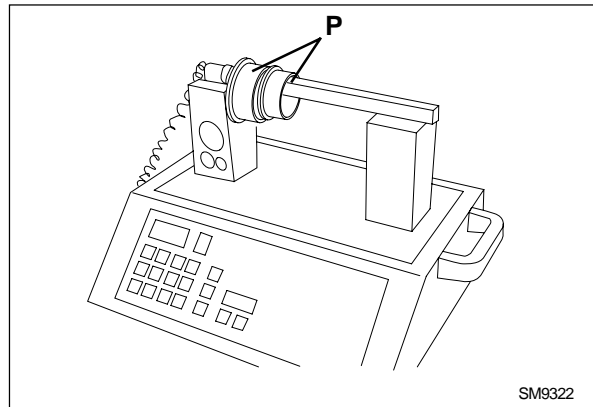

Fig. 36

Install races (P) onto the relevant seats on both sides of the shaft.

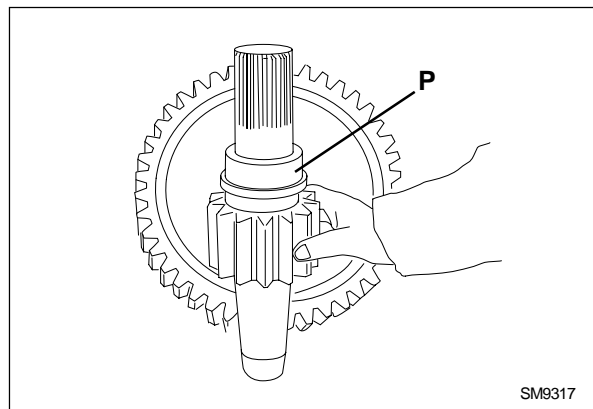

Fig. 37

Hold the shaft and idle gear (161) assembly and install it inside bearing housing (159) inside the final drive.

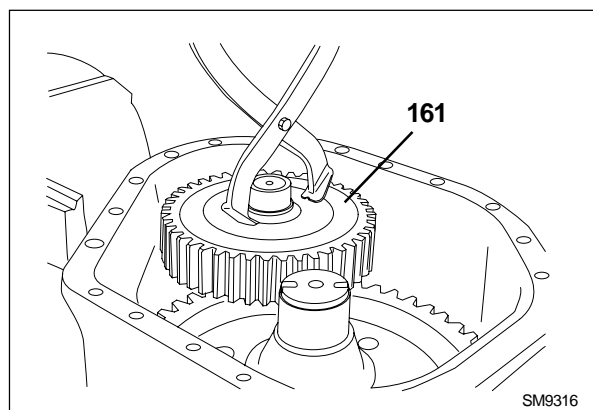
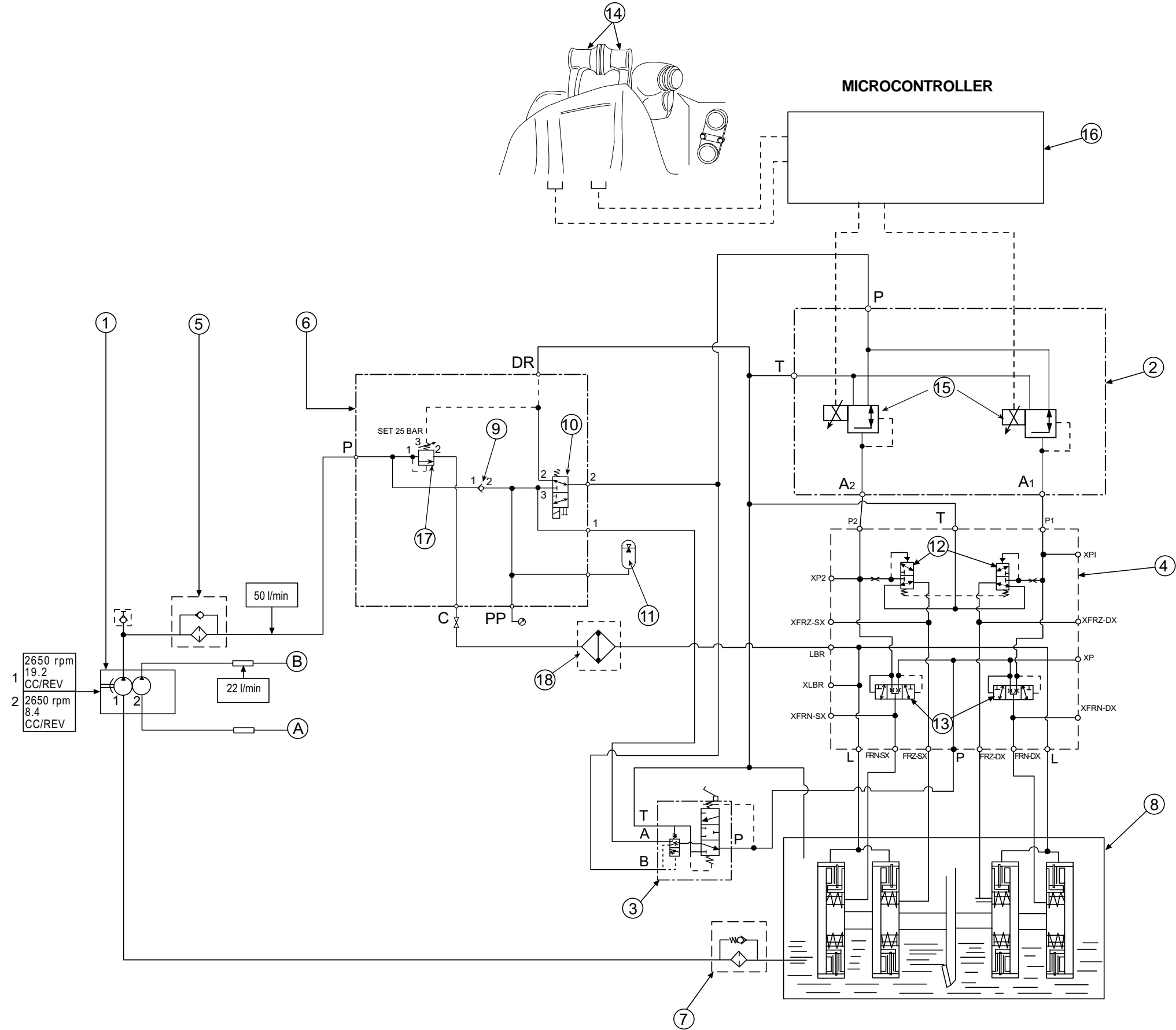

Fig. 38

BRAKES AND STEERING CLUTCHES SYSTEM HYDRAULIC DIAGRAM

1. Brakes and steering clutches feeding pump
 2. Proportional solenoid valves block
 3. Brake pedal valve block
 4. Brakes and steering clutches control valve
 5. Brakes and clutches delivery filter
 6. Feeding valve block
 7. Brakes and clutches suction filter
 8. Transmission housing
 9. Check valve
 10. Directional solenoid valve
 11. Accumulator
 12. Decompression valve
 13. Exchange valves
 14. Brakes and steering levers
 15. Proportional solenoid valves
 16. Microcontroller
 17. Pressure relief valve
 18. Housing oil radiator (air/oil)
- A. From torque converter
B. To transmission housing
- LBR-SX :** Left brake/clutch lubrication
FRN-SX : Left brake control
FRZ-SX : Left clutch control
LBR-DX : Right brake/clutch lubrication
FRN-DX : Right brake control
FRZ-DX : Right clutch control



REAR TRANSMISSION (transmission side section)

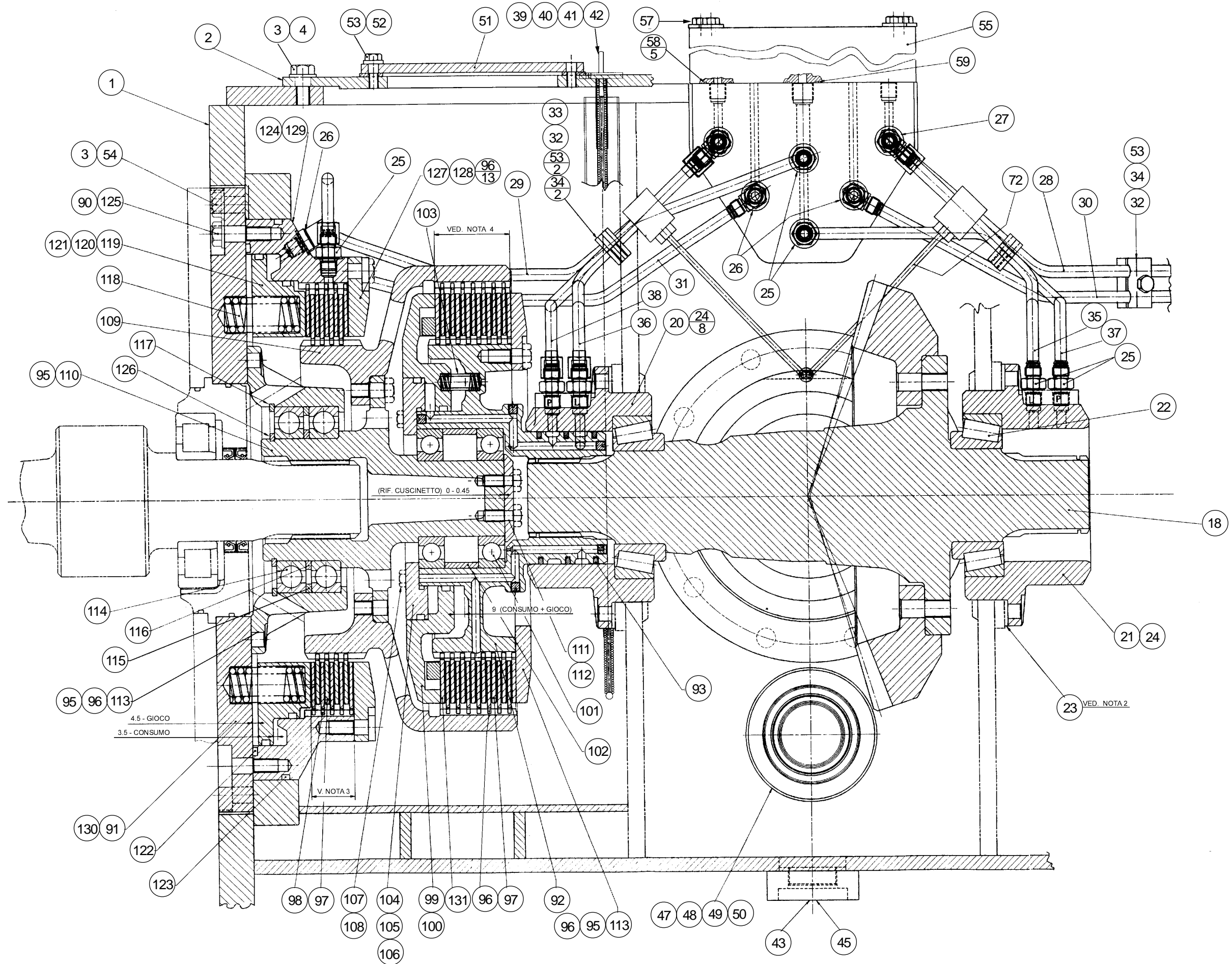

Position the starter switch in “ON” (second click of the key) and “_ _ _ _” appears on the display.

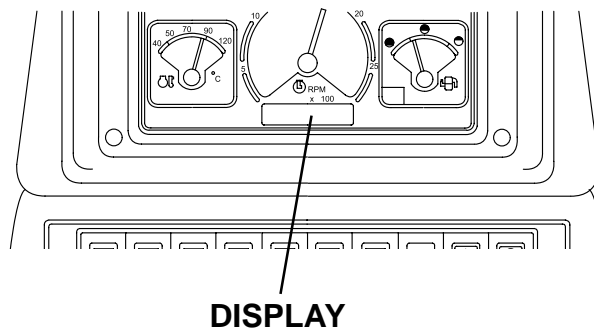
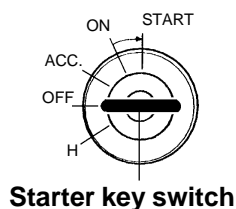

- Press neutral button “N” on the armrest (with this function, the control unit recognises the zero of the levers).
- “CAL1” appears on the display.
- Actuate, at the same time, both levers indicated to dull stroke. Staying in this position, the wording “E000” could appear on the display for a few seconds, then “_ _ _ _” appears.
 - With levers actuated to full stroke, press neutral button “N”.
 - The display shows “0”.
 - Release the levers into rest position.
- Reposition the starter key into “OFF”, remove cable (4) from connector (3).
 - Reinstall cap (2) on the connector and reinstall the plate on the cab post.

The calibration of the brakes/steering levers of the machine is completed.

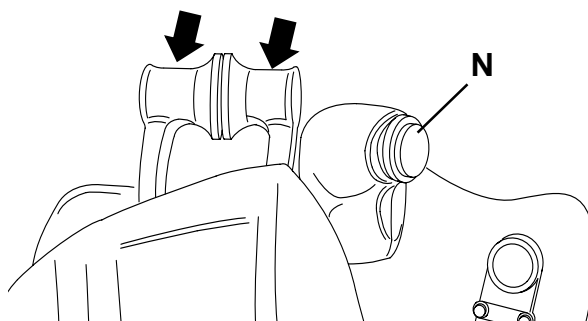

Install a puller to remove the bearing housing from the bevel crown shaft, until it gets out the taper spline together with its seat.
Repeat the operation on the opposite side of the housing.

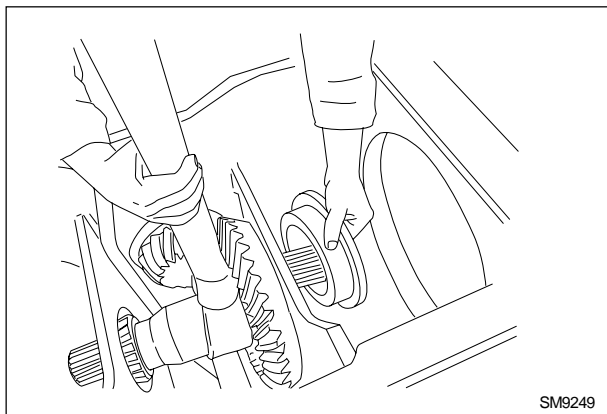

SM9249

Remove the shaft complete with crown gear, lifting it as shown in the figure.

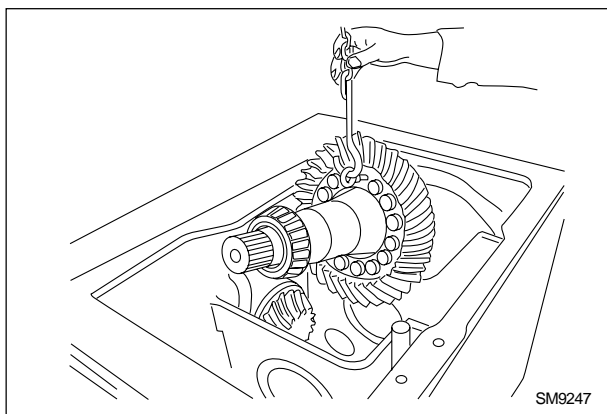

SM9247

Disassembly of the pinion

Secure the pinion into the appropriate bracket and place it in a vice.
Remove the cover using a screwdriver and remove the O-Ring.
Remove the pinion securing ring nut, using a socket, a torque wrench and a torque multiplier.
Install a bearing puller and remove the pinion from the bearings.

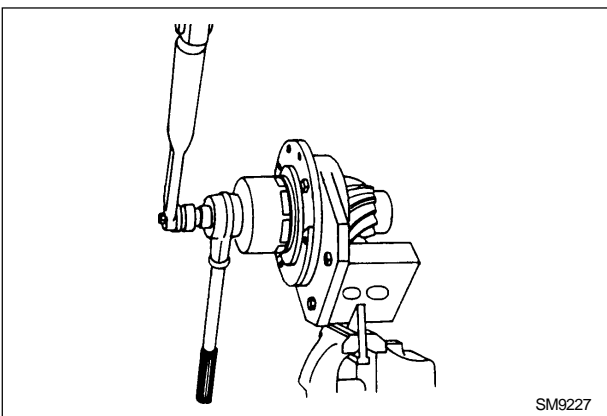

SM9227

- 5. Bevel gear set
- 6. Bearing
- 7. Bearing
- 8. Spacer
- 9. Bearing setting shim
- 10. Bearing housing
- 11. O-Ring
- 12. Bevel pinion ring nut
- 13. O-ring
- 14. O-Ring
- 15. Pinion cover
- 16. Half shims
- 17. Securing screw M16 x 1.5
- 18. Bevel gear shaft
- 19. Bevel gear securing screw M16 x 1.5

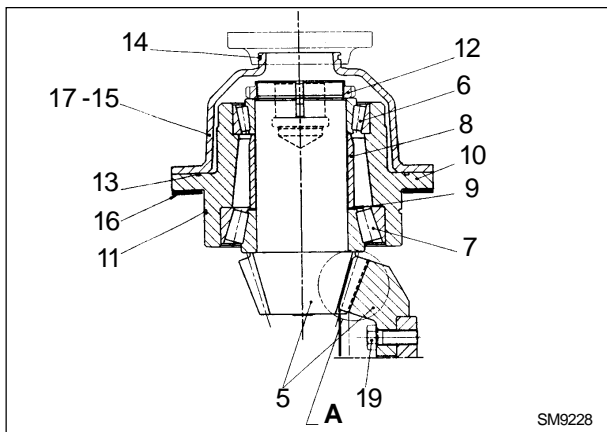

SM9228

4.5 SPECIFICATIONS AND DATA

4.5.1 BEVEL GEAR REDUCTION UNIT (General data / dimensions)

General data		Ref.
Type of gears	helical teeth	5
Reduction ratio (13/40)	1:3.076	5
Backlash between the face of the teeth	0.25 ÷ 0.33 mm (0.0098 to 0.0130 in) average 0.3 mm (0.0118 in)	5

Dimensions	mm	inches	Ref.
A Inner diameter of bevel gear shaft bearing cage	139.948 ÷ 139.988	5.5097 to 5.5113	21
Outer diameter of bearing	139.980 ÷ 140.000	5.5110 to 5.5118	22
* B Inner diameter of bearing	79.850 ÷ 80.000	3.1437 to 3.1496	22
Outer diameter of bevel gear shaft	80.020 ÷ 80.033	3.1503 to 3.1509	18
C Outer diameter of bevel gear shaft hub	239.948 ÷ 240.000	9.4467 to 9.4488	18
Inner diameter of bevel gear	240.000 ÷ 240.052	9.4488 to 9.4508	5
E Inner diameter of pinion housing	179.932 ÷ 179.972	7.0839 to 7.0855	10
Outer diameter of pinion bearing	179.975 ÷ 180.00	7.0856 to 7.0866	7
D Inner diameter of pinion support	149.932 ÷ 149.972	5.9028 to 5.9044	10
Outer diameter of bearing	149.980 ÷ 150.00	5.9047 to 5.9055	6

* NOTE: The dimensions are identical on both sides.

Pins and bushes are the components of the track chain most subject to wear. The symptoms characterising the wear of pins and bushes are wear of the sides of the links, fast wear of the sprocket teeth and excessive sagging of the track chains.

Shoes are single ribbed. The ribbing, besides providing traction, contribute to reinforcing the shoe. Worn shoes, besides facilitating the slipping of the track chains, are more easily deformed.

The track chain is permanently lubricated and the wear between pin and bush is greatly reduced. In fact, each pin (1) see fig. 2, has an axial hole (2) and two radial holes (3) perpendicular to the first one, providing a constant and continuous lubrication. The movement between pin and bush, ensures the distribution of lubricant over all the contact surfaces.

Fig.2 - Permanent lubrication (SALT) track chains

1. Pin with lube oil reserve drilling
2. Rubber plug
3. Radial lube drillings
4. Seal
5. Thrust ring
6. Bush
7. Link
8. Pin

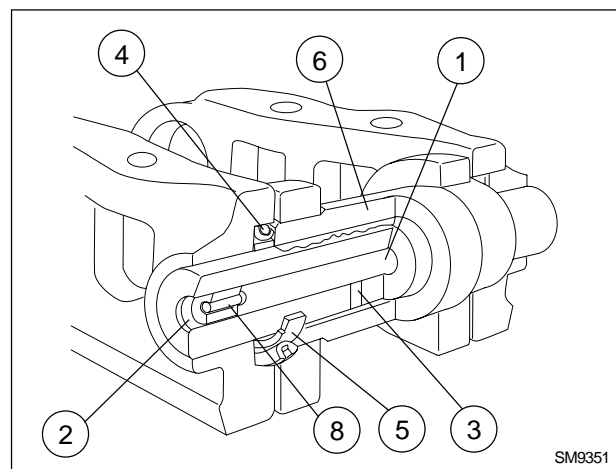

Seals (4) provide the sealing, avoiding the entry of foreign materials and keeping the lubricant. Rubber plug (2) allows the filling with oil and provides sealing.

NOTE - On lubricated track chain, it is recommended to turn pins and bushes, as well.

7. Toothed segment idler

The idler transfers, directly, to the track chain the rotation received from the final drive. The sprocket is mounted on the final drive output shaft. There are nine toothed segment bolted to the hub, thus they are individually replaceable. The profile of the teeth is of a self-cleaning type. The toothed segments can be replaced without removing the chains.

4. Remove the front seals (9 fig. 24) and keep the matching to avoid mixing them, when reassembling. Remove O-Rings (10).

Remove screws (11 fig. 26) securing the bush housings. Remove bush housings (2 fig. 27) assemblies forcing the idler shaft end (3) with a hydraulic press.

5. In case of replacement, press-out the bushes from the relevant housings, using an adequate punch.

6. Reassemble the components in the same manner as described in paragraph 5.4.5 **BOTTOM ROLLERS - Overhaul.**

7. Check the axial play of the idler, using dial gauge (A) as illustrated in fig. 28. The reading value to be obtained is listed in paragraph 5.5.1 **SPECIFICATIONS AND DATA - Idler.**

Reinstall the front seals, making sure that the metal ring faces are free from dents, scratches or traces of wear.

DEGREASE AND CLEAN THE FRONT SEAL SEATS. ELIMINATE ALL TRACES OF DUST OR IMPRINTS FROM THE SURFACES THEN COVER THEM WITH A THIN FILM OF OIL, MAKING SURE THAT THE OTHER SURFACES REMAIN DRY.



WARNING

Never use gasoline, solvents or other flammable fluids to clean components. Use approved non-toxic and non-flammable commercial solvents.

Reinstall idler supports (8 fig. 25) and block the idler shaft with screw (7) making sure, before tightening to torque, that item (9) is properly seated.

Reinstall the idler on the machine (see **Installation**).



WARNING

Handle all parts with extreme care. Never place hands and fingers between one piece and another. Wear approved personal protection equipment such as glasses, gloves and safety shoes.

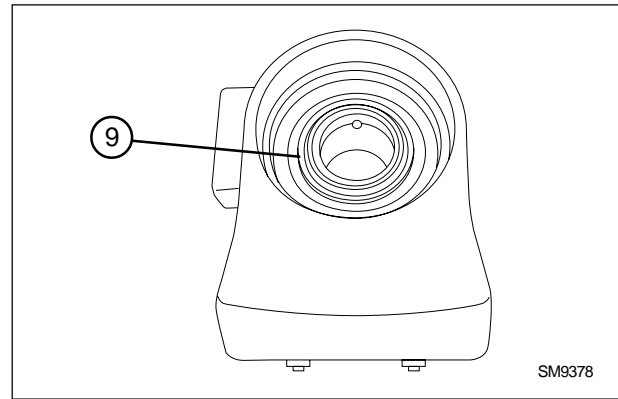

Fig. 24

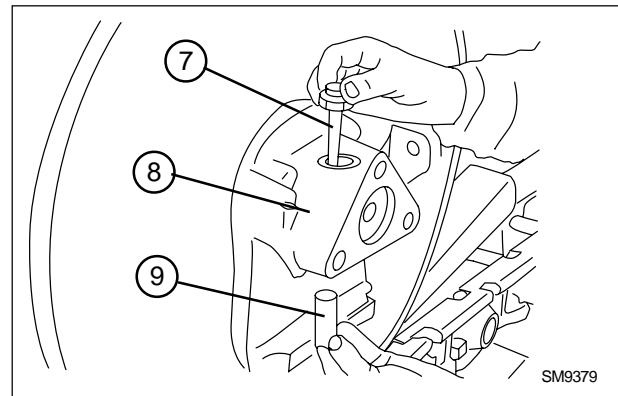

Fig.25

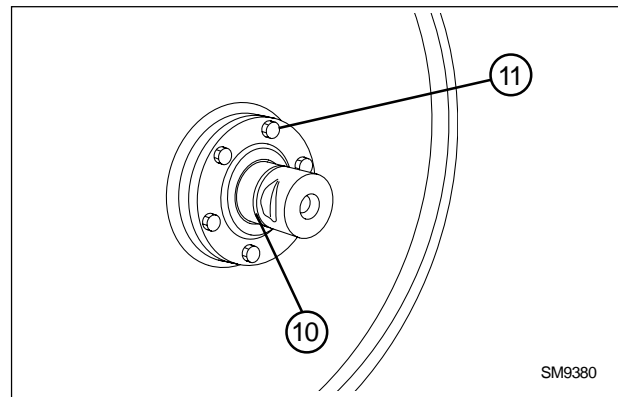

Fig.26

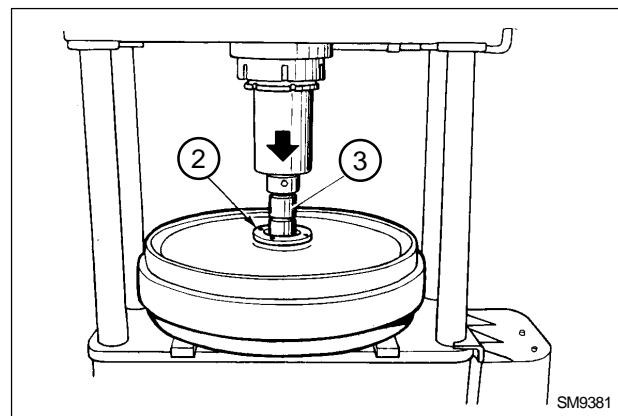

Fig.27

5.5 SPECIFICATIONS AND DATA

5.5.4 SUPPORT ROLLERS

Type permanently lubricated, equipped with metal (long-life) front seals.

- Quantity of rollers per track chain 2
- weight of roller assembly kg 32.57 (71.5 lbs)
- diameter of race 187.5 mm (7.38 in)
- diameter of outer flange 216 mm (8.50 in)
- quantity of oil (SAE 30/40) kg 0.370 (13 oz)
- diameter of shaft 57 mm (2.24 in)
- specs of material of support roller body according to standard PDQB 4000
- material of body 35 MB4 - 2

Tightening torque

Self-locking screws (C₁) securing the bush housings M10x1.25 (4.5 daNm)(33.19 ft lbs)

Self-locking screws(C₂) securing thrust washer M12x1.25 (6.5 daNm)(47.94 ft lbs)(*)

Plug (C₃) 19 daNm (140.12 ft lbs)

(*) Apply LOCTITE No. 243

Note - Before assembling, degrease and clean the front seal seats. Eliminate all traces of dust or imprints from the surfaces then cover them with a thin film of oil, making sure that the other surfaces remain dry.

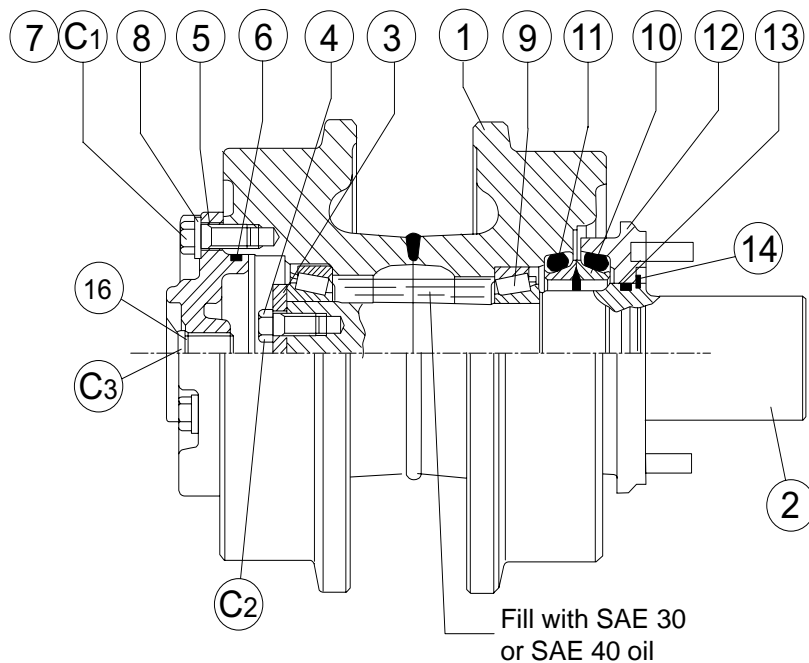

SM9404

Fig. 48 - Support roller

- 1. Support roller body; 2. Shaft; 3. Thrust washer; 4. Shaft lock screw; 5. Cover; 6. Cover seal; 7. Cover securing screw; 8. Flat washer; 9. Bearing assembly; 10. Sealing ring; 11. Elastic ring; 12. Collar with dowels; 13. Shaft seal; 14. Circlip; 15. Plug; 16. Plug seal.

BLADE HYDRAULIC TILT

The Tilt control is obtained by a sideways movement of the lever. The rightward movement of the lever causes the rightward tilting of the blade (clockwise rotation); in the same manner, the leftward movement of the lever causes the leftward tilting of the blade (anticlockwise rotation).

The Tilt control circuit is equipped with a flow reduction (7) limiting the flow of oil to the cylinder, facilitating the control of the blade. When the pump flow is reduced, oil operates lifting the valve plunger.

BLADE CONTROL LEVER POSITIONS

The lever controls the lifting, lowering and tilting of the blade.

To lift or lower the blade, move the lever respectively backward into position **D** or forward into position **H**.

The holding of the blade into a desired position occurs, in both instances, by releasing the lever, which returns automatically into neutral **N**.

To make the blade floating, bearing on the ground just under the effect of its weight, push the lever full stroke forward, into position **F**, where it is held by an appropriate detent.

The floating condition ends when returning the lever into neutral position **N**.

Moving the lever leftward into position **A**, or rightward into position **B**, the tilting of the blade is obtained. The lever must be held until the blade reaches the desired position.

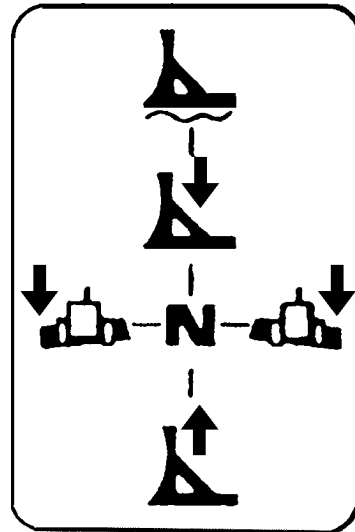

SM9474

Blade control lever positions decal

RIPPER CONTROL LEVER POSITIONS (upon request)

- With lever forward in **P** = ripper lowering.
- With lever backward in **R** = ripper lifting.
- Lever in **N** = neutral.

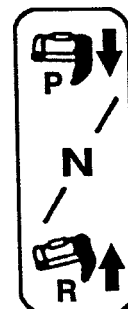

SM9475

Ripper control lever positions decal

6.4 REPAIR PROCEDURES

6.4.1 HYDRAULIC OIL RESERVOIR (Removal / installation)

Removal

Turn the main switch into "OFF" to cut-off the electrical system and apply a signal "DO NOT OPERATE" on the switch as illustrated.



WARNING

To minimise the risk of fires or explosions, prior to performing any welding operation on the fuel reservoir, it is recommended that the reservoir is fully drained, all pipes are disconnected, protecting their ends, and the inside of the reservoir is steam cleaned. Also all traces of fuel must be removed before starting welding.

Flood the reservoir with carbon dioxide (CO₂) before and during the welding operation.

While welding, all caps and covers must be removed and all then other openings kept open to provide ventilation.

Then, proceed as follows:

- lift the machine;
- drain the hydraulic oil from the reservoir using a container of at least 70 Lt (18 USGal) capacity, loosening the appropriate plug (T) located under the reservoir and magnetic rod (Z).
- disconnect the oil delivery and return pipes to the equipment control valve;
- disconnect the oil filter clogging indicator sensor connector (5 fig. 9) of the equipment hydraulic circuit.

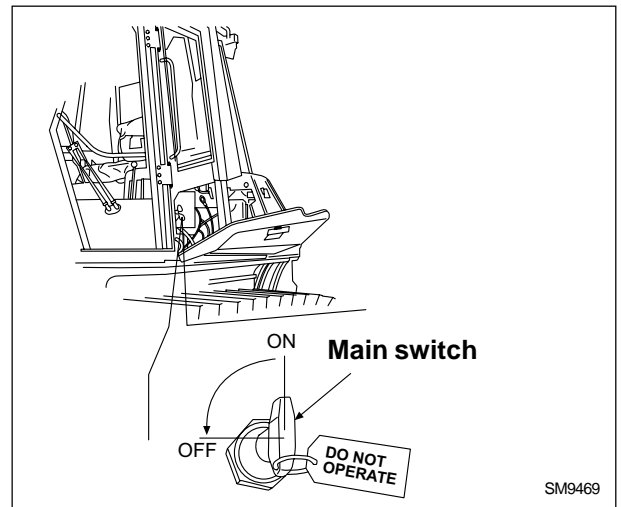

Fig. 7. Electrical system main switch

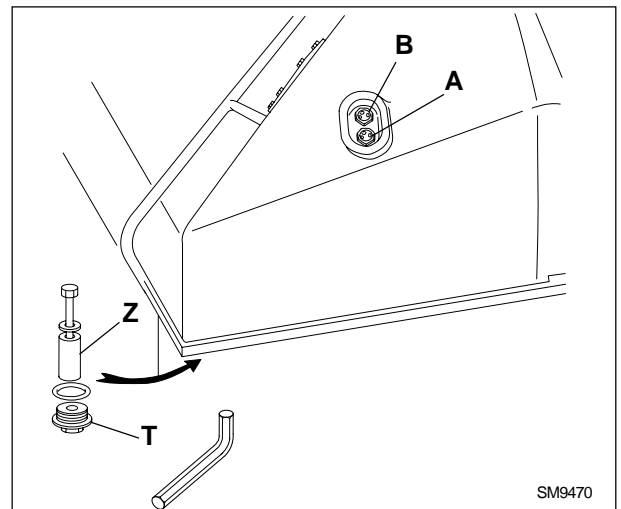
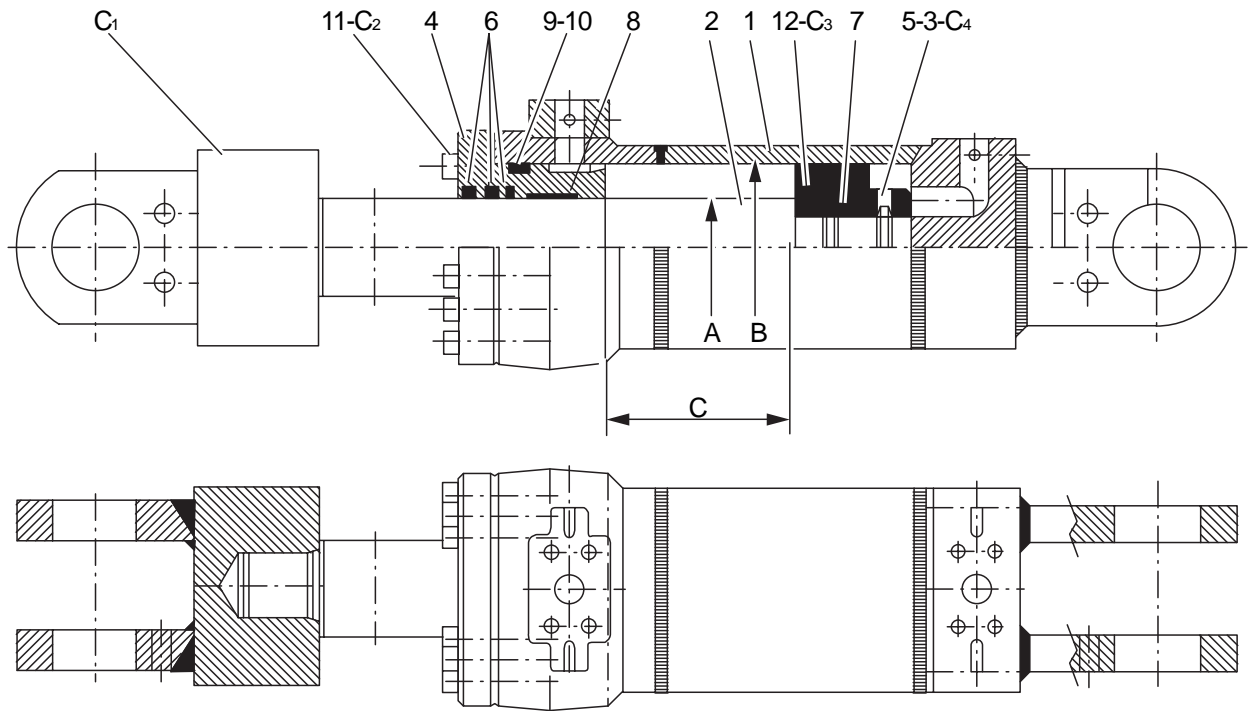

Fig. 8. Hydraulic oil reservoir

6.5 SPECIFICATIONS AND DATA

6.5.6 Blade tilt control cylinder
(Angledozer version)



SM9458

Fig. 22. Section of blade tilt cylinde

- A. Nominal diameter of rod 70 mm
- B. Nominal diameter of piston 110 mm
- C. Stroke of cylinder rod 124 mm
- C₁. Tightening torque 210 daNm
- C₂. Tightening torque of sleeve securing screw 8 daNm
- C₃. Tightening torque of piston M45x2 210 daNm
- C₄. Tightening torque of piston blocking screw M8x1.25 ... 1.6 daNm

1.	Sleeve ass.ly
2.	Rod ass.ly
3.	Steel ball
4.	Front sleeve
5.	Screw
6.	Seal ass.ly kit
7.	Seal
8.	Guide ring
9.	O-Ring
10.	Retaining ring
11.	Screw TCE M10 x 40
12.	Piston

FUSES

They protect the electrical system from damages caused by overloaded circuits. Replace the fuse when burnt-out. In the event a fuse of a determined circuit burns frequently, check the circuit and repair it, as required.

WARNING

Always replace fuses with parts of the same type and capacity. Otherwise the electrical system could be damaged.

WARNING

In the event it is necessary to replace frequently fuses, an electrical problem could exist.

Contact a FIAT-HITACHI Dealer.

Remove the pressure fitted covers on fuse boxes **A** and **B** in the cab.

The fuses protect:

FUSE BOX A (top mounted)

- 1 = Machine services solenoid/cab services - 5 Amp
- 2 = Cut-off (hold) - Operator safety levers - 5 Amp
- 3 = Start safety - 5 Amp
- 4 = Buzzer - Monitor - Optional - 5 Amp
- 5 = Operator safety relay - 5 Amp
- 6 = Horn - 5 Amp
- 7 = Micro Controller - 7.5 Amp
- 8 = Transmission control buttons - 5 Amp
- 9 = Cab ceiling lights - Cigarette lighter - Voltage reduction - 7.5 Amp
- 10 = Front work lights - 5 Amp
- 11 = Rear work lights - 5 Amp

FUSE BOX B

- 1 = Front lights - Symbol lighting - 7.5 Amp
- 2 = Heater electric fan - 20 Amp
- 3 = R.H. door wiper
- 4 = L.H. door wiper - Door washer pump - 7.5 Amp
- 5 = Rear wipers - 7.5 Amp
- 6 = Front wipers - Front and rear washers - 7.5 Amp
- 7 = Condenser fan - 20 Amp
- 8 = Pre-heater relay - Pre-heater ind. light - 5 Amp
- 9 = Socket and EPROM - 5 Amp
- 10 = Optional
- 11 = Not used



WARNING

Always disconnect the ground cable of the battery prior to cleaning, repairing, connecting or disconnecting any wire of the electrical system, to prevent personal injuries.

Always keep all lights equipping the machine efficient. Replace burnt-out bulbs at once.

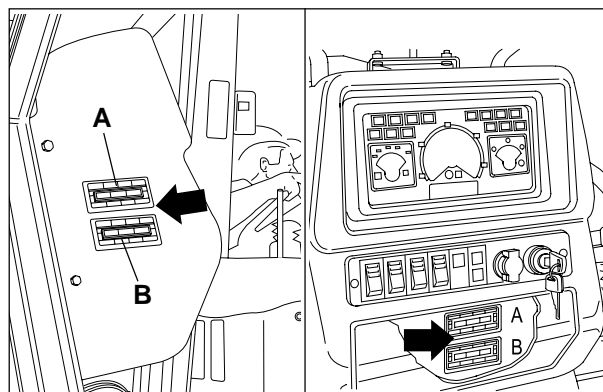

on CABINE

on ROPS

SM9501

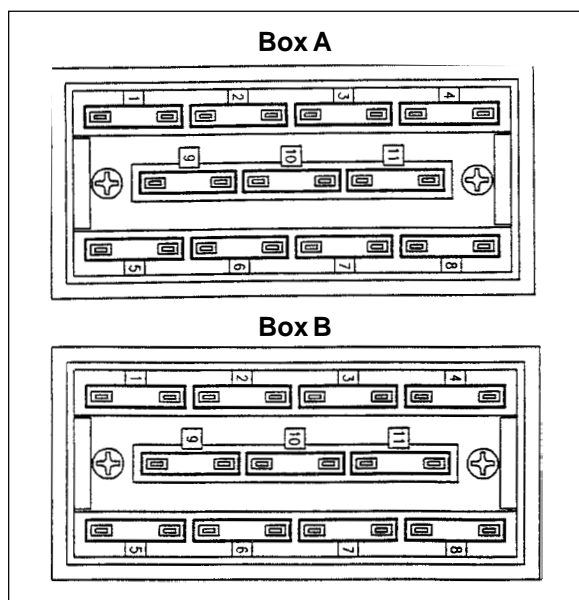

SM9502

CLICK HERE TO **DOWNLOAD** THE COMPLETE MANUAL

- Thank you very much for reading the preview of the manual.
- You can download the complete manual from: www.heydownloads.com by clicking the link below



- Please note: If there is no response to CLICKING the link, please download this PDF first and then click on it.

CLICK HERE TO **DOWNLOAD** THE COMPLETE MANUAL