

**CX15B
CX18B
Series 2**
Mini Excavator

SERVICE MANUAL

Part number 84533370B

English

May 2014

Copyright © 2014 CNH Industrial Italia S.p.A. All Rights Reserved.

CASE
CONSTRUCTION

CLICK HERE TO **DOWNLOAD** THE COMPLETE MANUAL

- Thank you very much for reading the preview of the manual.
- You can download the complete manual from: www.heydownloads.com by clicking the link below



- Please note: If there is no response to CLICKING the link, please download this PDF first and then click on it.

CLICK HERE TO **DOWNLOAD** THE COMPLETE MANUAL

INTRODUCTION

15. Repairs which require welding should be performed only with the benefit of the appropriate reference information and by personnel adequately trained and skilled in welding procedures. Determine the type of metal being welded and select the correct welding procedure and electrodes, rods or wires to provide a metal weld strength at least equivalent to that of the parent metal. Make sure to disconnect the battery before any welding operation is performed.
16. Do not damage wiring during removal operations. Reinstall the wiring so it is not damaged nor will be damaged in operation of the machine by contacting sharp corners, or by rubbing against some object or hot surface. Do not connect wiring to a line containing fluid.
17. Be sure all protective devices, including guards and shields, are properly installed and functioning correctly before starting a repair. If a guard or shield must be removed to perform the repair work, use extra caution and replace the guard or shield after repair is complete.
18. Performing maintenance and repair operations while the bucket is lifted is dangerous, because there is the possibility of a device falling. Do not fail to lower such device and place the bucket to the ground before starting the operation.
19. Loose or dirty fuel, lubrication and hydraulic systems, pipes and hoses may cause fires. Do not bend or strike high-pressure lines, do not install bent or damaged lines. Inspect lines, tubes and hoses carefully. Do not check for leaks with your hands. Very small (pinhole) leaks can result in a high velocity oil jet that will be invisible close to the hose.
This oil can penetrate the skin and cause personal injury. Use card-board or paper to locate pinhole leaks.
20. Tighten connections to the correct torque. Make sure that all protections against burns, the clamps and the operator's protective devices are correctly installed in order to prevent excessive heat, vibrations or rubbing against other parts during operation. Shields that protect against oil spray onto hot exhaust components in event of a line, tube or seal failure must be installed correctly.
21. Do not operate a machine if any rotating part is damaged or contacts any other part during operation. Any high speed rotating component that has been damaged or altered should be checked for balance before reusing.
22. Be careful when servicing or separating the tracks. Chips can fly when removing or installing a track pin. Wear safety glasses and long sleeve protective clothing. Tracks can unroll very quickly when separated. Keep away from front and rear of machine. The machine can move unexpectedly when both tracks (crawlers) are disengaged from the sprockets. Block the machine to prevent it from moving.

Torque specifications for sleeve type tube fitting

Sleeve type tube fittings

Tube size Outside diameter x thickness	Wrench size	Tightening torque
10 mm (0.4 in) x 1.5 mm (0.1 in)	19 mm	44 N·m (32.5 lb ft) ± 4.9 N·m (3.6 lb ft)
15 mm (0.6 in) x 2.0 mm (0.1 in)	27 mm	147 N·m (108.4 lb ft) ± 20 N·m (14.8 lb ft)
18 mm (0.7 in) x 2.5 mm (0.1 in)	32 mm	177 N·m (130.5 lb ft) ± 20 N·m (14.8 lb ft)
22 mm (0.9 in) x 3.0 mm (0.1 in)	36 mm	216 N·m (159.3 lb ft) ± 20 N·m (14.8 lb ft)
28 mm (1.1 in) x 4.0 mm (0.2 in)	41 mm	275 N·m (202.8 lb ft) ± 29 N·m (21.4 lb ft)
35 mm (1.4 in) x 5.0 mm (0.2 in)	55 mm	441 N·m (325.3 lb ft) ± 44 N·m (32.5 lb ft)

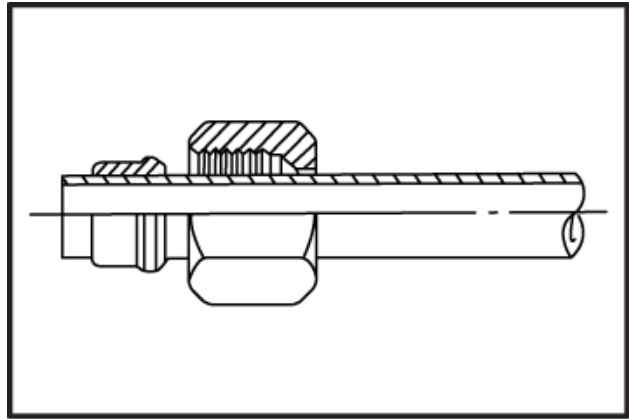

SMIL13MEX0050XA 6

Product identification - Machine orientation

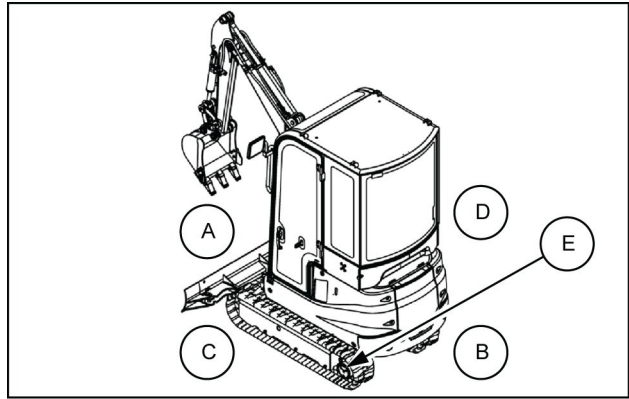

The terms right-hand, left-hand, front, and rear are used in this manual to indicate the sides as they are seen from the operator seat when the travel motors are positioned at the rear and the operator is facing the direction in which the machine advances (forward).

- A Front of machine
- B Rear of machine
- C Left side of machine
- D Right side of machine
- E Travel motor

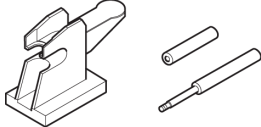
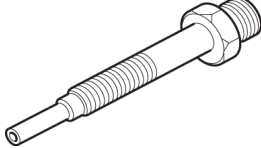
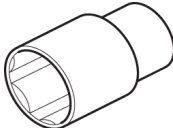

SMIL13MEX0315AB 1

Engine - Special tools

Name	Shape	Function
Piston pin setting tool.		For pulling out and press fitting piston pins.
Compression gauge adapter.		For measuring compression.
Oil pressure switch key (26) .		For removing and installing oil pressure switch.
Piston ring pliers.		Range applicable for removing and installing piston rings: 60 - 95 mm (2.36 - 3.74 in)

Engine serial number

The engine serial number (No.) is stamped on the injection pump mount (upper side of tie rod cover) of the cylinder block.

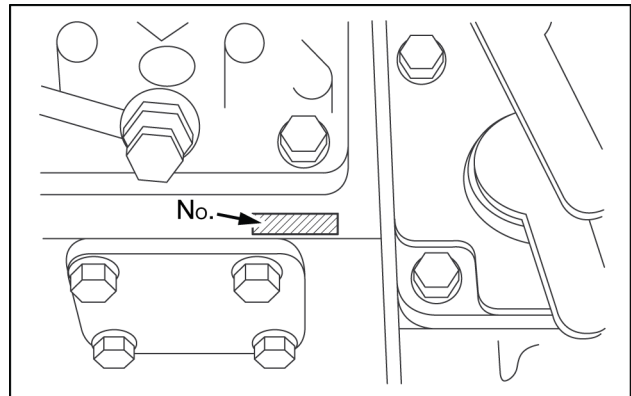

TULI12EXN3145AB 2

Engine model and total displacement

The engine type and displacement are stamped on the side of the injection pump mount of the cylinder block.

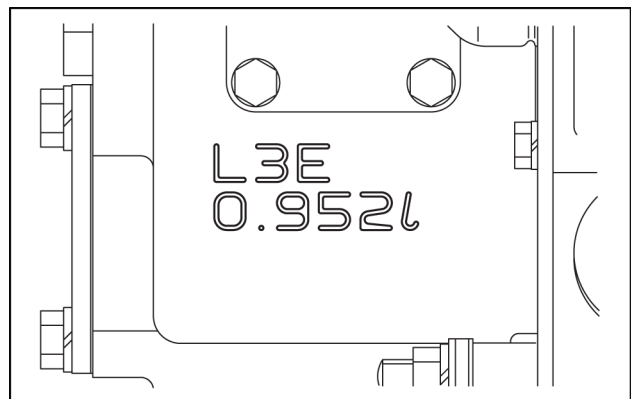

TULI12EXN3146AA 3

Bleeding fuel system

NOTICE: Completely wipe off any spilled fuel from air vent screws with a cloth or the like, as spilled fuel can cause a fire.

Bleeding of the fuel system must be carried out closest to the fuel tank: bleed the fuel filter first, then the injection pump.

Air bleeding from fuel filter

1. Deliver fuel by solenoid pump.
2. Place the cock of the fuel filter in the "OPEN" position (O).
3. Press (P) and hold the button until the filter body cup (1) is filled with fuel.
4. Stop the fuel supply.

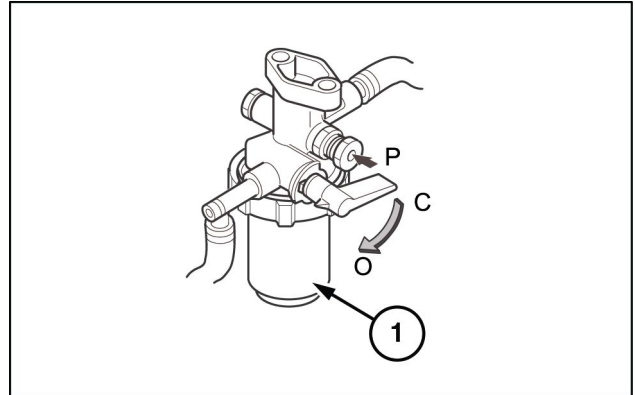

TULI12EXN3519AB 9

Air bleeding from water separator

1. Loosen the water separator's bleed plug for fuel supply (1).
2. Deliver fuel by solenoid pump.
3. Tighten air bleed plug for fuel inlet when the fuel flow from the air bleed plug becomes free of bubbles.
4. Loosen air bleed plug for fuel outlet (2).
5. Tighten air bleed plug for fuel outlet when the fuel flow from the air bleed plug becomes free of bubbles.
6. Stop the fuel supply.

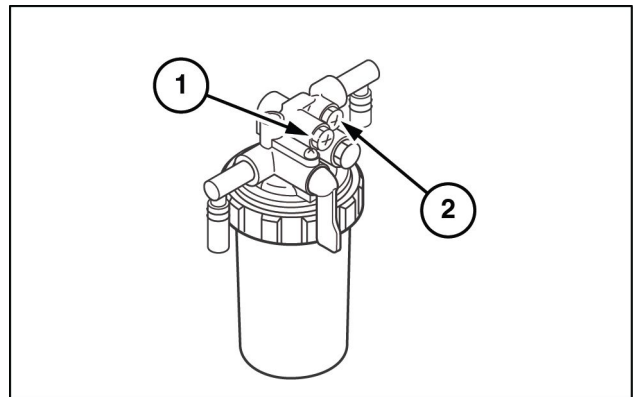

TULI12EXN3520AB 10

Overheating

Check items before troubleshooting

Quantity and leakage of coolant

Loosening of fan belt

Clogging of radiator fins

Concentration of LLC

Clogging of muffler

Quantity and degradation of engine oil

Swirling of cooling air

Thermostat malfunction

Problem: Overheating

Overheating is caused by a disalignment of engine load during engine setting.

If the engine itself is normal and overheat occurs, measure the ambient and coolant temperatures in the loaded condition (thermostat full open).

If the temperature difference is greater than **60 °C (140 °F)**, the investigation into other components as well as the engine is suggested.

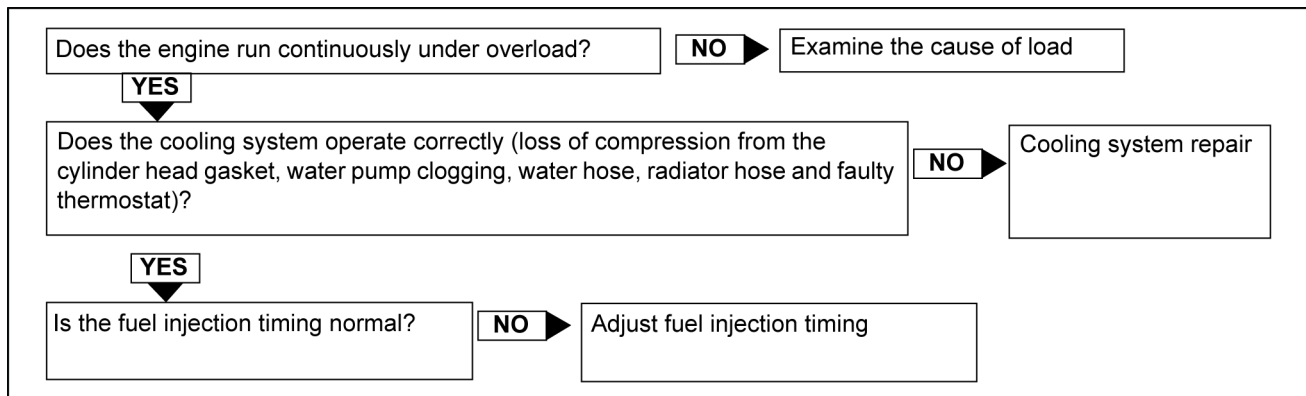

TULI12EXN3498EA 3

Engine oil pan - Assemble

Installation of oil filter

1. Turn the engine upside down to face up the oil pan mounting surface.
2. Install the oil filter so that the tip of the screen does not contact the oil pan.

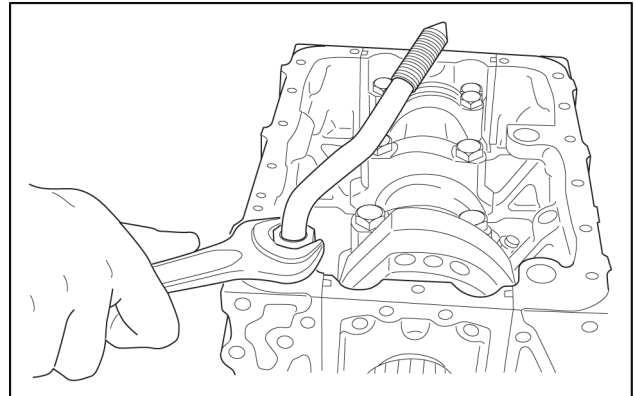

TULI12EXN3355AA 1

Installation of oil pan

1. Install new oil pan gasket.
2. Tighten oil pan bolts evenly and diagonally.

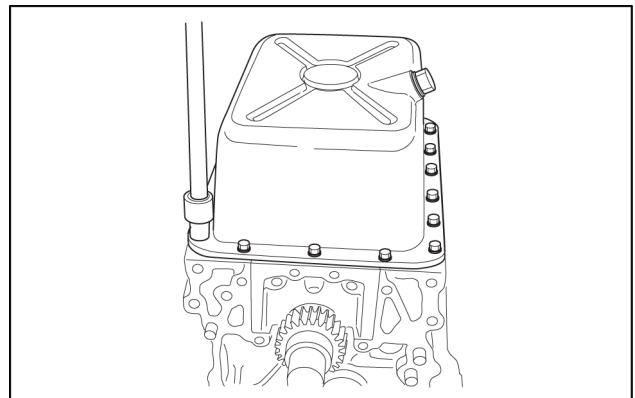

TULI12EXN3356AA 2

Camshaft - Disassemble

Disassembly of idler gear

1. Remove the snap ring (36).
2. Remove the idler gear (19).

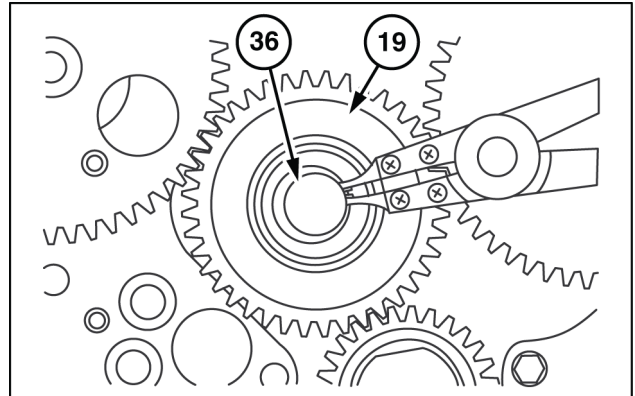

TULI12EXN3176AB 1

Disassembly of camshaft

NOTICE: When pulling out the camshaft, be careful not to cause damage to the cam lobe of the camshaft and the camshaft hole of the cylinder block.

1. Remove the stop screws of the camshaft (37).
2. Extract the camshaft (21) with the gear (20) and the bearings (21).

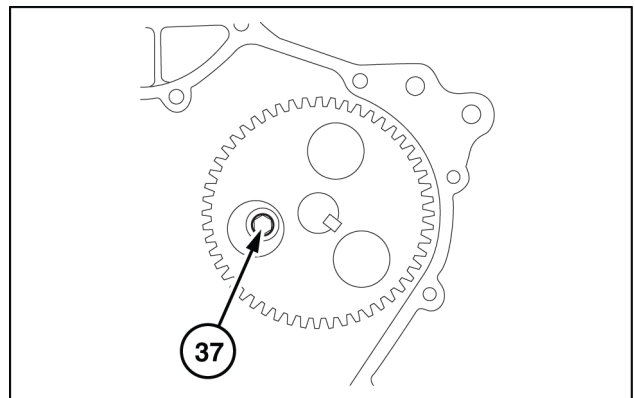

TULI12EXN3177AB 2

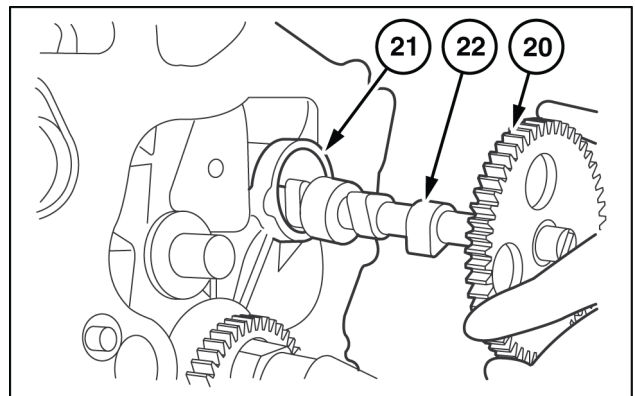

TULI12EXN3178AB 3

Camshaft gear - Disassemble

1. Loosen and remove the screws **(33)** and a stud **(32)**.
2. Screw in a screw in the threaded hole of the stud and remove the flange **(3)** from the gear pump.

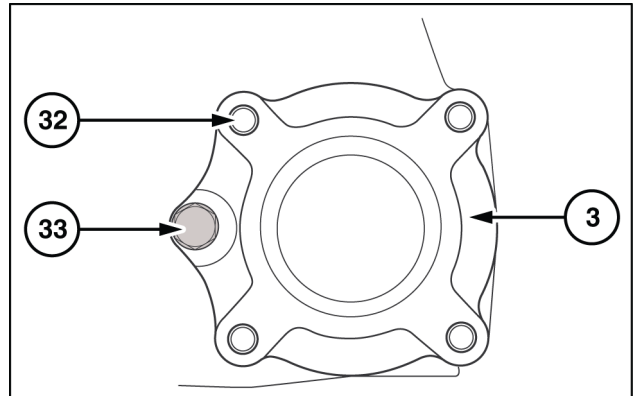

TULI12EXN3169AB 1

Retouching valve face

1. Grind remarkably worn valve faces with a valve rectifier.

NOTE: Grind the valve face with a rectifier (1) at the specified angle.

Secure the valve margin width equal to or greater than the limit. Replace valves with new ones if their dimensions after refacing do not meet the standard.

2. (A) Set the valve face angle at the specified angle.

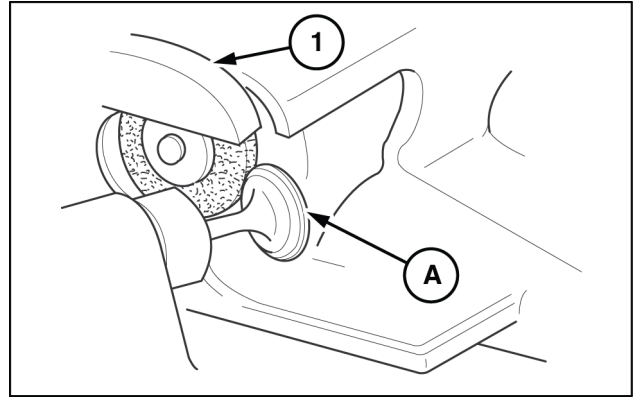

TULI12EXN3200AB 8

Measuring perpendicularity and free length of valve spring

Measure the perpendicularity and free length of the valve spring. Replace the valve spring if the limit is exceeded.

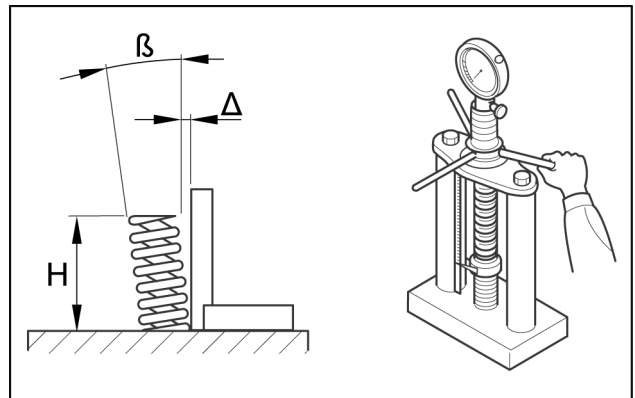

TULI12EXN3301AA 9

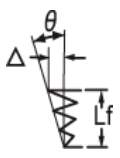
Item	Standard	Allowable limit
Free length H	40 mm (1.575 in)	38.5 mm (1.516 in)
Perpendicularity	 <p> $\theta = 2.0^\circ$ or less D (gap) = 1.4 mm (0.055 in) or less Lf = 40 mm (1.575 in) </p>	total length 2 mm (0.079 in)
Setting length/load	35.5 mm (1.398 in)/ 64.1 - 71.0 N (14.4 - 16.0 lb) 28 mm (1.102 in)/ 170.1 - 189.4 N (38.2 - 42.6 lb)	-0.15%

Measurement of clearance between connecting rod bearing and pin

NOTICE: When grinding crank pins, be sure to grind all the pins to the same size.

Finish the fillet radius to the specified dimension.

1. Reassemble the bearing into the big end of the connecting rod.
2. Tighten the connecting rod cap bolts to the specified torque.
3. Measure the inner diameter of the connecting rod bearing.
4. Measure the outer diameter of the crank pin.

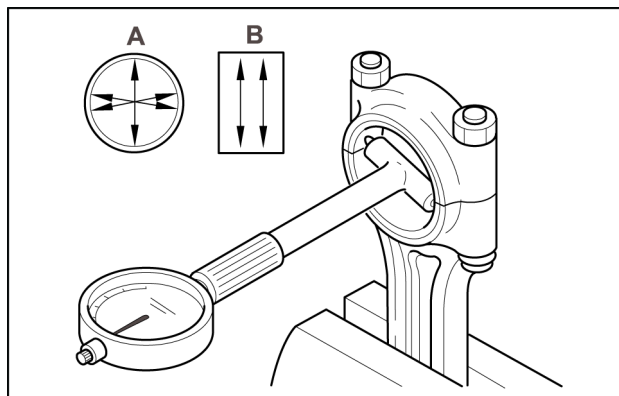

TULI12EXN3326AA 10

5. Calculate the clearance between the inner diameter of the connecting rod bearing and the outer diameter of the crank journal.
6. Replace the connecting rod bearing if the clearance exceeds the limit.
7. Measure the clearance between the connecting rod bearing and the crank pin again. Use the undersize bearing if the limit is exceeded.
8. If an undersize bearing is used, grind the crank pin to the specified undersize.

A. Measuring directions

B. Measuring points

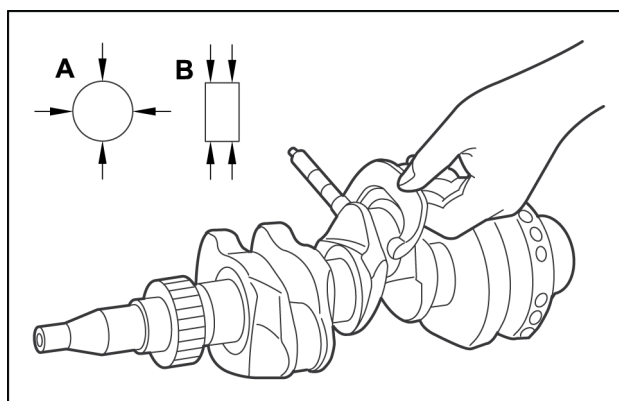

TULI12EXN3327AA 11

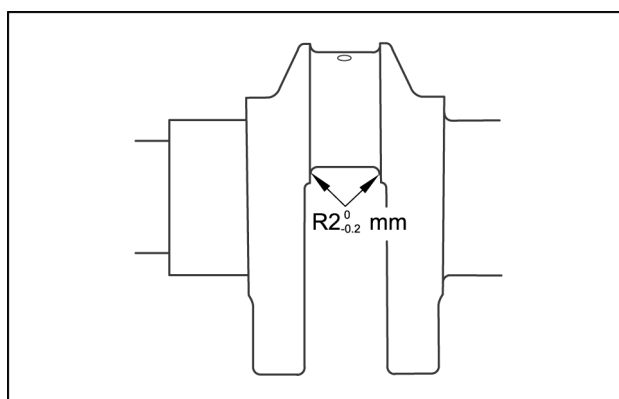

TULI12EXN3328AA 12

Item	Nominal	Standard	Allowable limit
Pin outer diameter (STD)	ø40 mm (1.575 in)	39.965 - 39.98 mm (1.573 - 1.574 in)	-0.7 mm (-0.028 in)
Clearance between connecting rod pin and bearing	-	0.028 - 0.071 mm (0.001 - 0.003 in)	0.15 mm (0.006 in)

Item	Undersize	Finish dimension
Pin undersize	0.25 mm (0.010 in)	ø39.715 - 39.73 mm (1.564 - 1.564 in)
	0.50 mm (0.020 in)	ø39.465 - 39.48 mm (1.554 - 1.554 in)

Disassembly of valves and valve springs

NOTICE: Be careful not to cut your hands with the ring gear when pulling out the flywheel.
Pay attention not to drop or hit the flywheel while removing it.

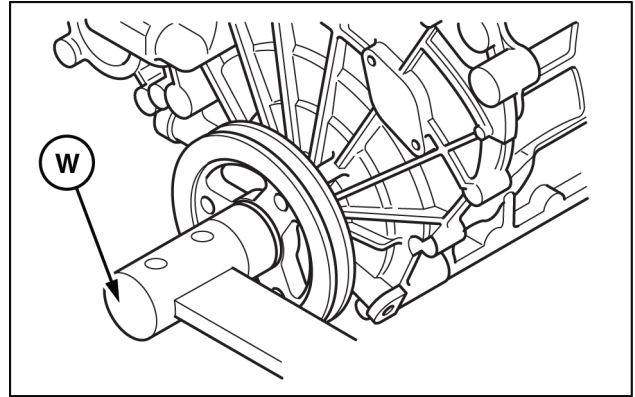

TULI12EXN3163AB 2

1. Firmly hold the pulley with a wrench (**W**) to prevent the flywheel from turning.
2. Loosen and remove one screw from the flywheel.
3. Screw in a guide screw (**G**) in the threaded hole of the removed screw.
4. Loosen and remove the remaining screws from the flywheel (**1**).
5. Hold the flywheel (**1**) firmly with both hands and, by moving it back and forth, pull it out straight.

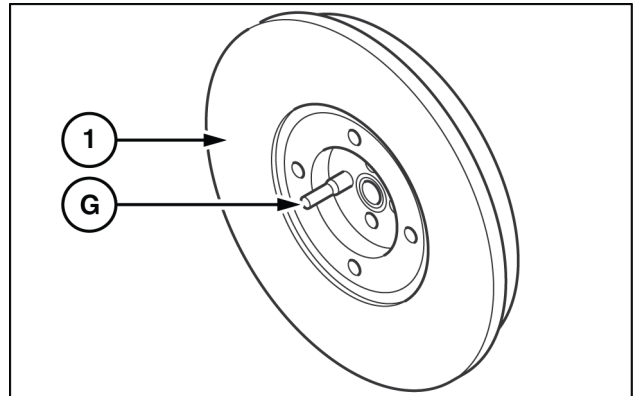

TULI12EXN3164AB 3

NOTE: The ring gear is shrink fitted to the flywheel. Do not remove it unless defective.

Disassembly of rear plate

Loosen and remove the screw of the rear plate. Remove the rear plate (**2**).

NOTE: When removing the rear plate (**2**), firmly hold it with both hands and pull the rear plate straight out by moving it back and forth, as the rear plate is located near the bushing.

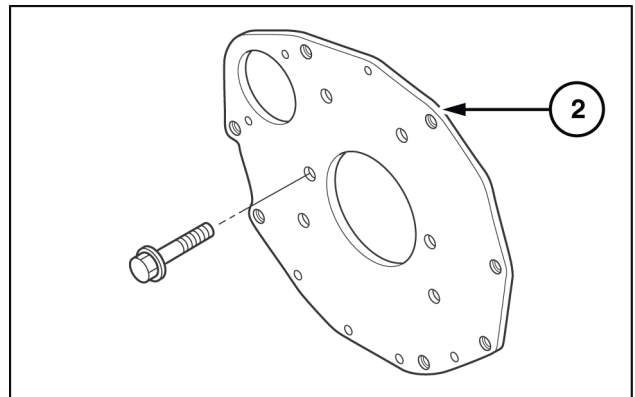

TULI12EXN3165AB 4

Measurement of the distortion of the cylinder block top surface

NOTE: Limit the depth of surface grinding of cylinder block to a necessary minimum. If the surface of cylinder block is ground more than specified, it may result in defects such as defective combustion and stamping (contact between piston and valve).

1. Apply a straight edge to the top surface of the cylinder block and measure its distortion with a feeler gauge.
2. If the distortion exceeds the limit, grind the cylinder block with a surface grinder.

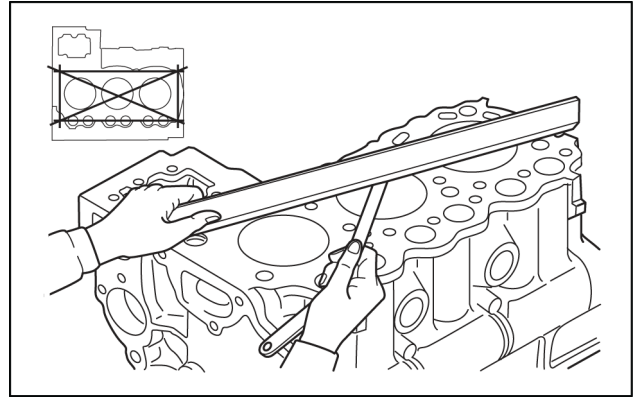

TULI12EXN3334AA 6

Item	Standard	Allowable limit
Distortion of cylinder block top surface	0.05 mm (0.002 in) or less	0.1 mm (0.004 in)

Injection pump - Remove

NOTE: Check thickness of the fuel injection timing adjusting shim.

- (1) Screw
- (2) Fuel pump
- (3) Gasket

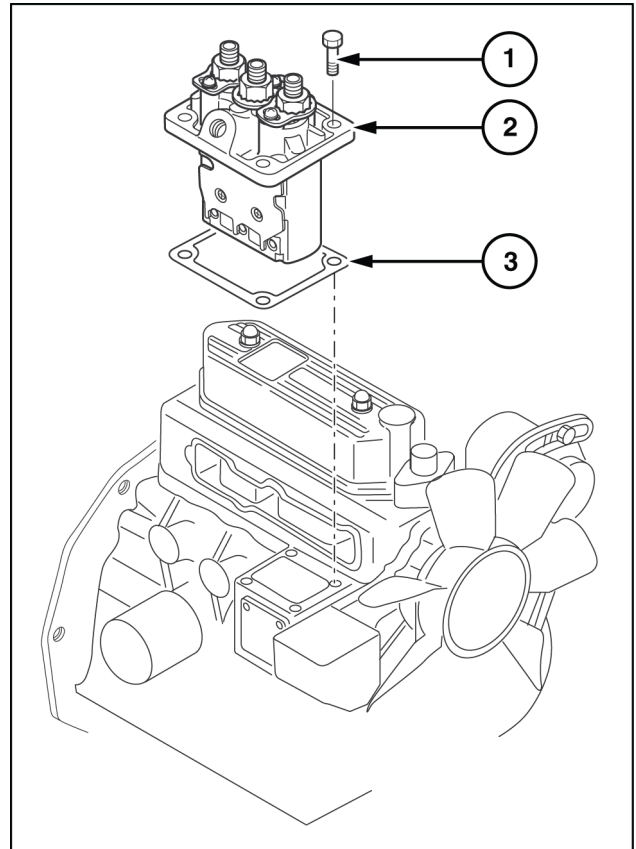

TULI12EXN3401BB 1

- Place the stamped side of the piston (**8**) to the opposite side of the protrusion of the sleeve (**11**) (opposite side to the crosspiece side). Assemble the spring lower seat on the piston and insert it into the control sleeve.

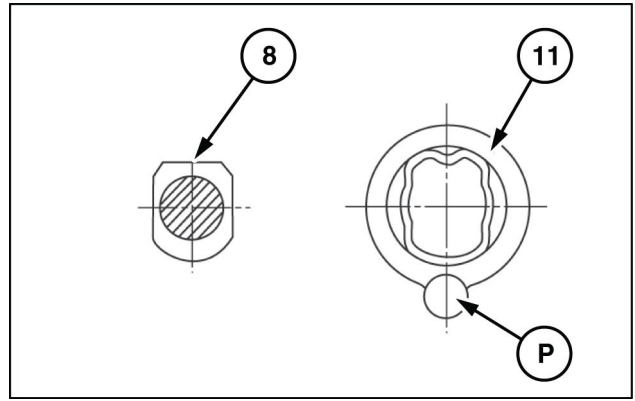

TULI12EXN3422AB 6

Pusher installation

- Install the shim (**6**).
- Install the pusher (**5**) so that its groove is oriented towards the pin hole (**4**).

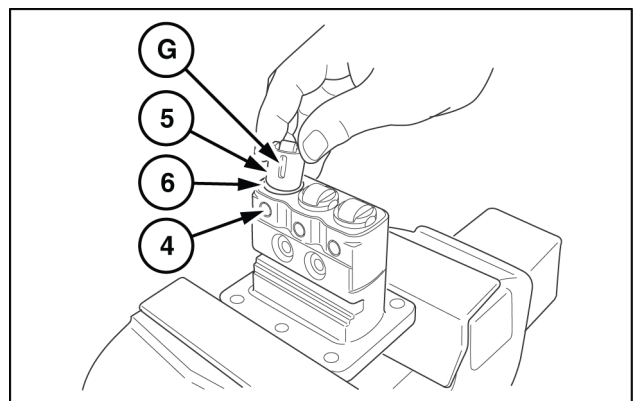

TULI12EXN3423AB 7

- Push down the pusher (**5**) and install the pin (**4**).

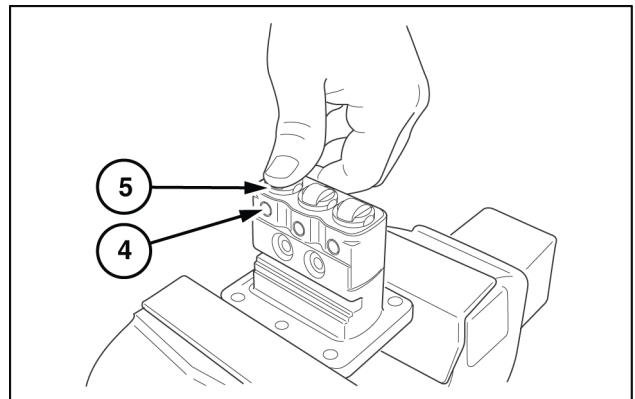

TULI12EXN3424AB 8

Crosspiece assembly

- Align the sleeve (**11**) so that the protrusion (**P**) of the control sleeve matches the fork (**F**) of the control crosspiece (**3**).
- Install the control crosspiece (**3**).
- Install the stop wire bracket.
- Tighten the screws to the specified torque.

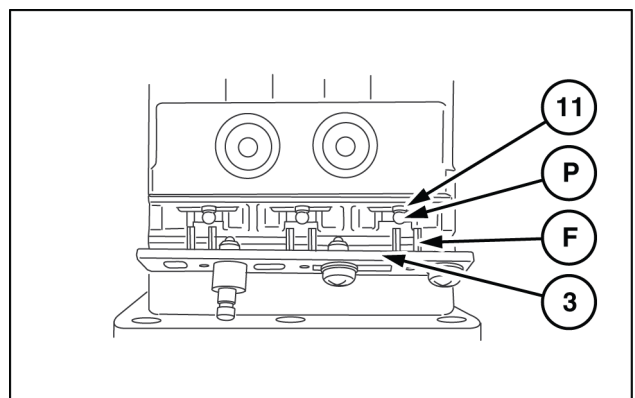

TULI12EXN3425AB 9

Contents

Engine - 10

Air cleaners and lines - 202

SERVICE

Air cleaner	
Remove	3
Install	4

Intake and exhaust manifolds and muffler - Inspect

1. Suction pipe
2. Inlet cover
3. Exhaust manifold

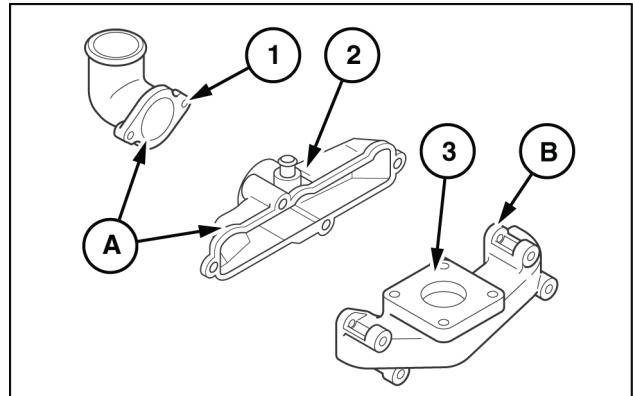

TULI12EXN3470AB 1

Checks

- A. Cracks, damage, contamination, dirt, corrosion
- B. Cracks, damage, corrosion

Measurement of deformation of inlet cover and exhaust manifold

Using a level (1) and a thickness gauge (2), measure the deformation on the cylinder head mounting sur-faces of the inlet cover and exhaust manifold. If the measured deformation exceeds the limit, grind or re-place the part.

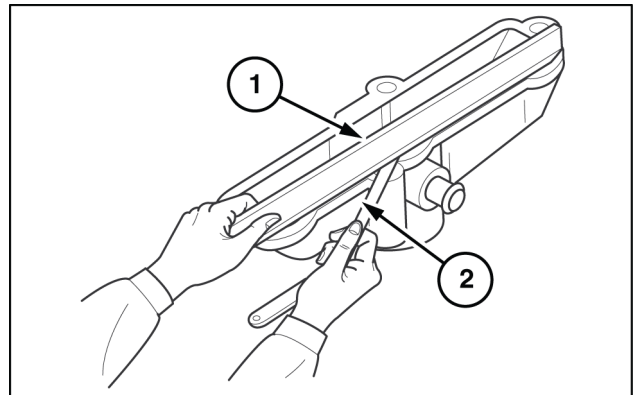

TULI12EXN3471AB 2

Item	Allowable limit
Distortion on mounting surfaces of inlet cover and exhaust manifold	0.15 mm (0.006 in)

Engine cooling system - Install

Installation of pulley, belt, thermostat, switch and water pump

1. Fan
2. Spacer
3. Pulley
4. Belt
5. Thermostat body
6. Switch
7. Pipe
8. Water pump

For switch assembly (6), tighten it to the prescribed tightening torque of **19.6 - 29.4 N·m (14.5 - 21.7 lb ft)**.

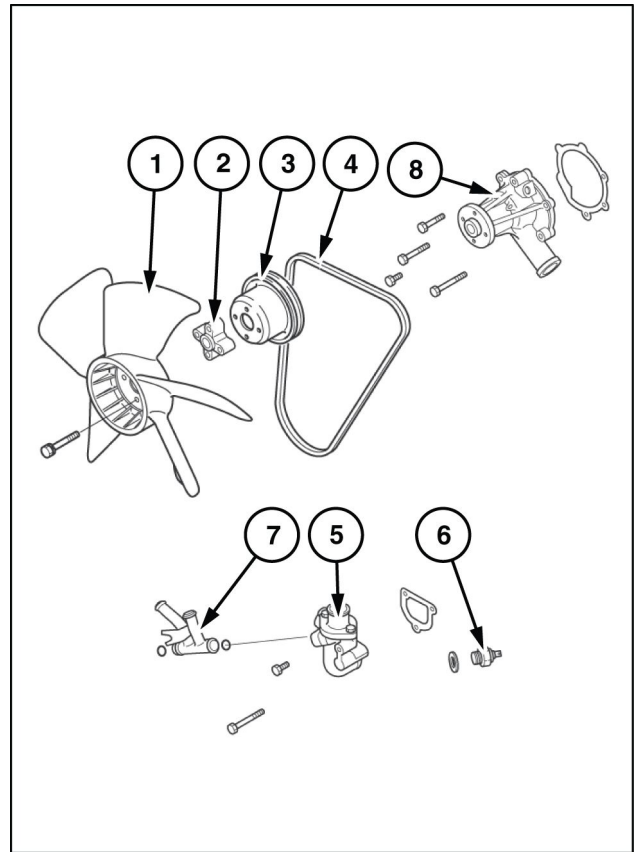

TULI12EXN3463BB 1

Contents

Engine - 10

Engine lubrication system - 304

TECHNICAL DATA

Engine lubrication system	
Torque	3
Service limits	3

FUNCTIONAL DATA

Engine lubrication system	
Component identification	4

SERVICE

Engine lubrication system	
Remove	5
Inspect	8
Install	10

Installation of relief valve

Insert the piston and the spring into the gear case and tighten the plug (2) to the specified tightening torque of **39.2 - 28.9 N·m (28.9 - 21.3 lb ft)**.

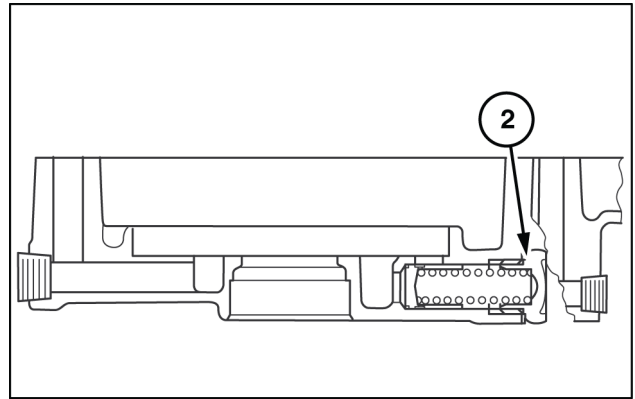

TULI12EXN3460AB 5

Oil filter installation

1. Apply a light coating of engine oil to the filter gasket.
2. Tighten the filter (1) by hand. When the filter gasket contacts the support surface, tighten the filter.

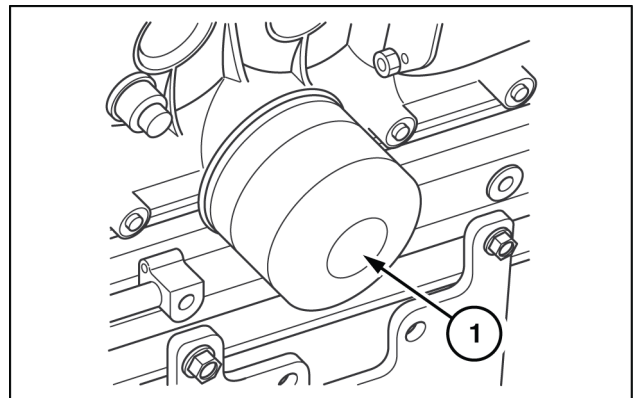

TULI12EXN3461AB 6

(A) Apply engine oil.

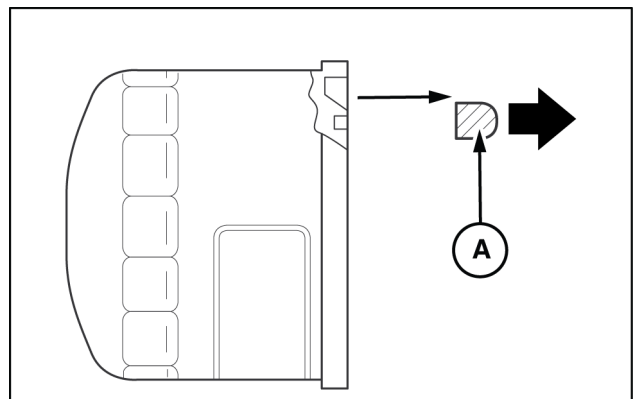

TULI12EXN3462AB 7

1. Pump
2. Control valve
3. Slewing motor
- 4/A. Right travel motor
- 4/B. Left travel motor
5. Boom cylinder
6. Arm cylinder
7. Bucket cylinder
8. Swing cylinder
9. Dozer cylinder
10. Swivel joint
- 11/A. Right control lever valve
- 11/B. Left control lever valve
12. Travel pedals valves
13. Solenoid valve
14. Return filter
15. Suction filter
16. Check valve
17. Oil tank

BOOM OPERATION

Hydraulic pilot system allows to operate, through the right control lever, the boom.

Boom raising

Pilot circuit

- Boom control spool
When the right control lever is put at boom raising position, the pilot valve **(11/A)** controls the pressurized oil entering into the **Pb8** port on control valve **(2)** and allows the activation of boom control spool.

Main circuit

- Boom cylinder **(5)** circuit, head side
Oil flow coming from **P1** port of pump **(1)** enters to **P1** port of control valve **(2)** and, through the boom control spool, reaches the **B8** port. Oil flow coming from port **B8** flows to head side of boom cylinder **(5)** to activate the boom raising function.

Boom lowering

Pilot circuit

- Boom control spool
When the right control lever is put at boom lowering position, the pilot valve **(11/A)** control the pressurized oil entering into the **Pa8** port on control valve **(2)** and allows the activation of boom control spool.

Main circuit

- Boom cylinder **(5)** circuit, bottom side and return oil circuit
Oil flow coming from **P1** port of pump **(1)** flows to the boom control spool of control valve **(2)** and supplies bottom side of boom cylinder **(5)** to lower the boom. Boom cylinder **(5)** head side return flow enters into **B8** port of control valve **(2)**, passes through boom control spool and reaches the discharge port of control valve. To avoid a non-controlled boom lowering, the lowering control of boom spool is provided with a flow cocking of cylinder bottom side delivery flow and an adjusted restriction on cylinder head side return circuit.

NIBBLER / BREAKER OPERATION (OPTIONAL)

Operation is controlled by pedal which drives the cable to operate the valve. This function is activated regardless to the safety lock lever.

NIBBLER (CLOSE) OPERATING CIRCUIT

Put the nibbler/breaker selector valve to nibbler position.

Nibbler operation

Pressing the left side of the control pedal, the cable is pulled and consequently the nibbler valve spool of control valve **(2)** is activated.

Main circuit

Supply circuit for nibbler cylinder: Oil flows coming from **P1** and **P2** ports of variable pump flow into **P1** and **P2** port of control valve **(2)**, pass through independent travel valve and join together upwards of nibbler/breaker section, supplying the head side of nibbler cylinder (closing of nibbler).

Return: Return flow coming from nibbler cylinder enters into **A1** port of control valve **(2)**, flows through the nibbler/breaker spool and reaches the discharge port of control valve.

HYDRAULIC BREAKER ACTIVATION

Put the nibbler/breaker selector valve to breaker position.

Breaker operation

Pressing the right side of the control pedal, the cable is pushed and it activates the nibbler/breaker section of control valve **(2)**.

Main circuit

Supply circuit for breaker: Operation is similar to nibbler operation.

Return: Breaker return oil flow directly reaches the valve **(18)** and, then, the hydraulic oil tank but it does not flow through the control valve **(2)**.

BUCKET OPERATION

Hydraulic pilot system allows to operate, through the right control lever, the bucket.

Bucket digging operation circuit

Pilot circuit

- Bucket control spool
When the right control lever is put at bucket digging position, the pilot valve **(12/A)** controls the pressurized oil entering into the **Pa9** port of control valve **(2)** and allows the activation of bucket control spool.

Main circuit

- Bucket cylinder **(7)** circuit, head side
Oil flow coming from **P1** port of pump **(1)** enters into **P1** port of control valve **(2)** and, through the bucket control spool, reaches the **A9** port. Oil flow coming from port **A9** flows to head side of bucket cylinder **(7)** to activate the digging function. The return oil flow coming from bottom side of bucket cylinder **(7)** flows through the bucket spool and reaches the discharge port of control valve.

Bucket dumping operation

Pilot circuit

- Bucket control spool
When the right control lever is put at bucket dumping position, the pilot valve **(12/A)** controls the pressurized oil entering into the **Pb9** port of control valve **(2)** and allows the activation of bucket control spool.
Bucket spool shifting.

Main circuit

- Bucket cylinder **(7)** circuit, bottom side
Oil flow coming from **P1** port of pump **(1)** enters into **P1** port of control valve **(2)** and, through the bucket control spool, reaches the **B9** port. Oil flow coming from **B9** port flows to the bottom side of bucket cylinder **(7)** to activate the dumping function. The return oil flow coming from head side of bucket cylinder **(7)**, flows through the bucket spool and reaches the discharge port of control valve.

TRAVEL / DOZER COMBINED OPERATION

When travel/dozer combined function is activated, straight travel is not activated.

Travel/dozer lowering operation

Pilot circuit

Travel is controlled by the pilot hydraulic system and the dozer is controlled by operating cable.

Main circuit

The flows coming from **P1** and **P2** ports of the variable pump enter into **P1** and **P2** ports on the control valve **(2)** and reach the travel motors **(4/A)** and **(4/B)** through the travel motor spool and through the swivel joint **(11)**. Flow coming from **P3** port of fixed pump enters into **P3** port of control valve **(2)** and reaches the dozer cylinder **(9)** through the dozer spool and the swivel joint **(11)**.

Dozer is operated by the pressurized oil supplied by the third pump: in this way, there is no flow adjustment on (right and left) travel motors and the independent travel and flow conflux valve is not activated.

MEASURING TRAVEL PERFORMANCE

Test procedures

Make 3 test measurements.

Use average resulting values for the evaluation.

Machine travel

Travel speed (5 complete revolutions)

Engine: High idle.

Hydraulic oil temperature: **50 - 60 °C (122 - 140 °F)**.

Measuring position: The machine body is lifted using both the hoe attachment and the dozer.

Start the crawlers. After one complete revolution, measure the time necessary for 5 complete revolutions. (Measure speed only after it has stabilized).

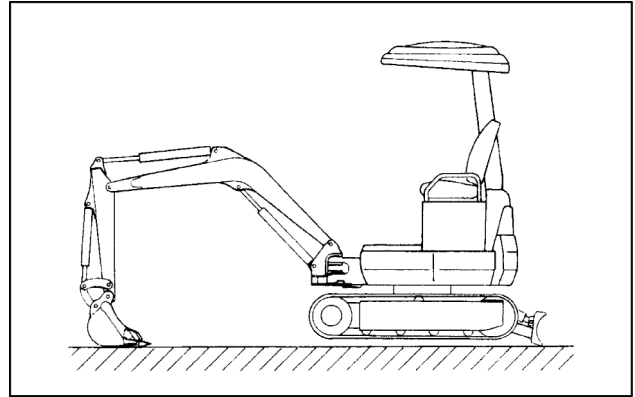

TULI12EXN2619AA 9

Travel speed (10 m (33 ft))

Engine: Nominal RPM.

Hydraulic oil temperature: **50 - 60 °C (122 - 140 °F)**.

Measuring position: Travel position.

Start the machine. After travelling for **5 m (16 ft)**, measure the time necessary for travelling **10 m (33 ft)**. Perform this operation on a level and firm ground.

Travel position: Fully extend the arm and the arm cylinders and place the hoe attachment so that its lower part is even with the machine's minimum ground clearance. The hoe attachment must be empty and the dozer must not touch the ground.

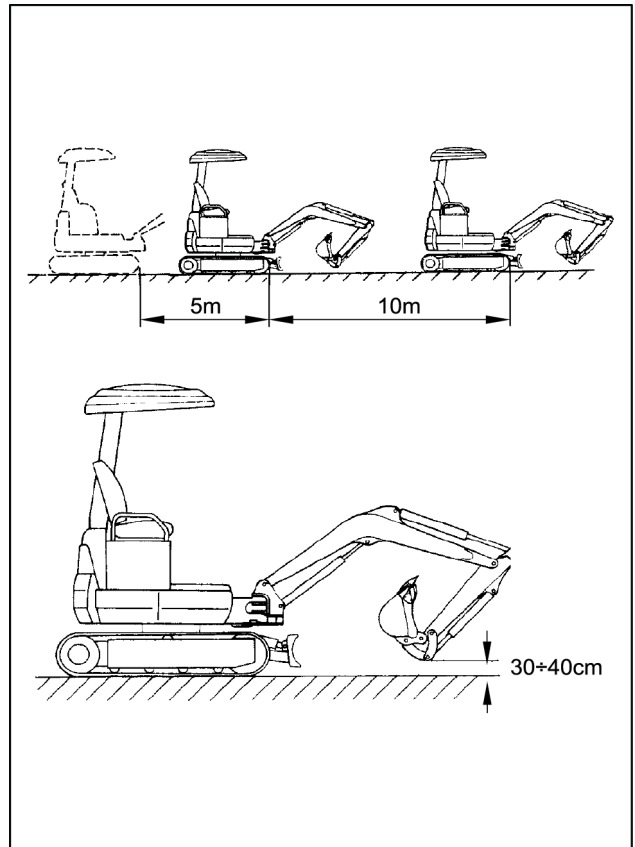

TULI12EXN2620BA 10

Hydraulic systems - Service instruction – Troubleshooting

General precautions

Troubleshooting provides the procedure to investigate the cause of trouble when a problem occurs. This manual describes how to systematically solve a specific problem as quickly as possible. For the troubleshooting concerning the inside of equipment, refer to the troubleshooting for each manual of the equipment.

Confirm actual troubled conditions at site

Get to the site as quickly as possible.
Check the machine model, serial number, fault condition and position, and inform the user of the arrival time of the possible spare parts.

Check the possible causes of the trouble occurred

Model name and serial number.

Type of attachment.

Check that the combination of attachments was proper and that the operating manner was not unreasonable.

Operating time on the hour meter.

Record of troubles. First trouble or repeated trouble.

History of the trouble and additional modifications.

Recurrence of the same trouble in the past or trouble due to additional modification.



TULI12EXN3135AA 1

How to diagnose trouble

Check the defective part.

Reproduce the fault conditions.

If the defective part cannot be checked, make systematical assumptions as regards the various possible causes.

Check the assumed cause.

Report the repairing method, the procedures used and the repairing modes to the user.



TULI12EXN3136AA 2

Slewing speed is low (CX18B)

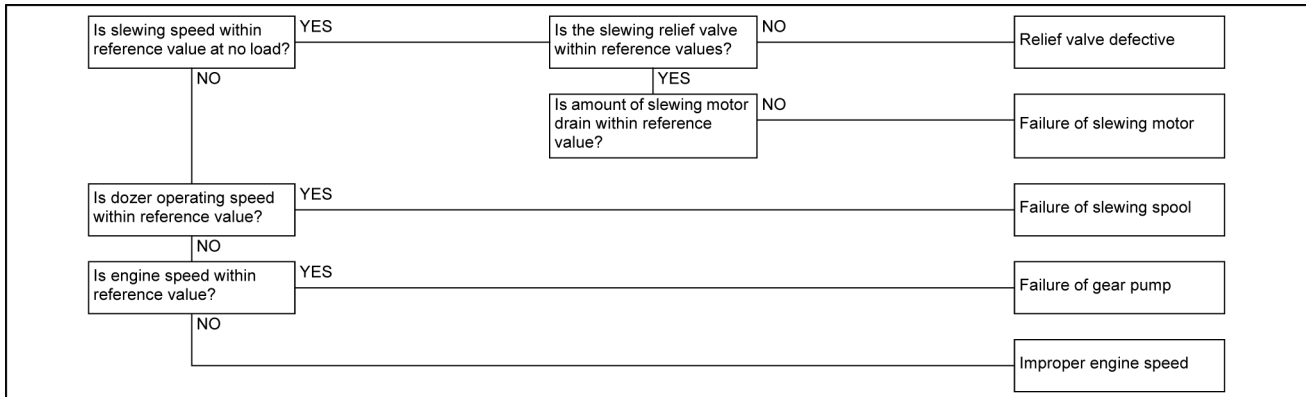

TULI12EXN3484EA 14

Slewing force is low

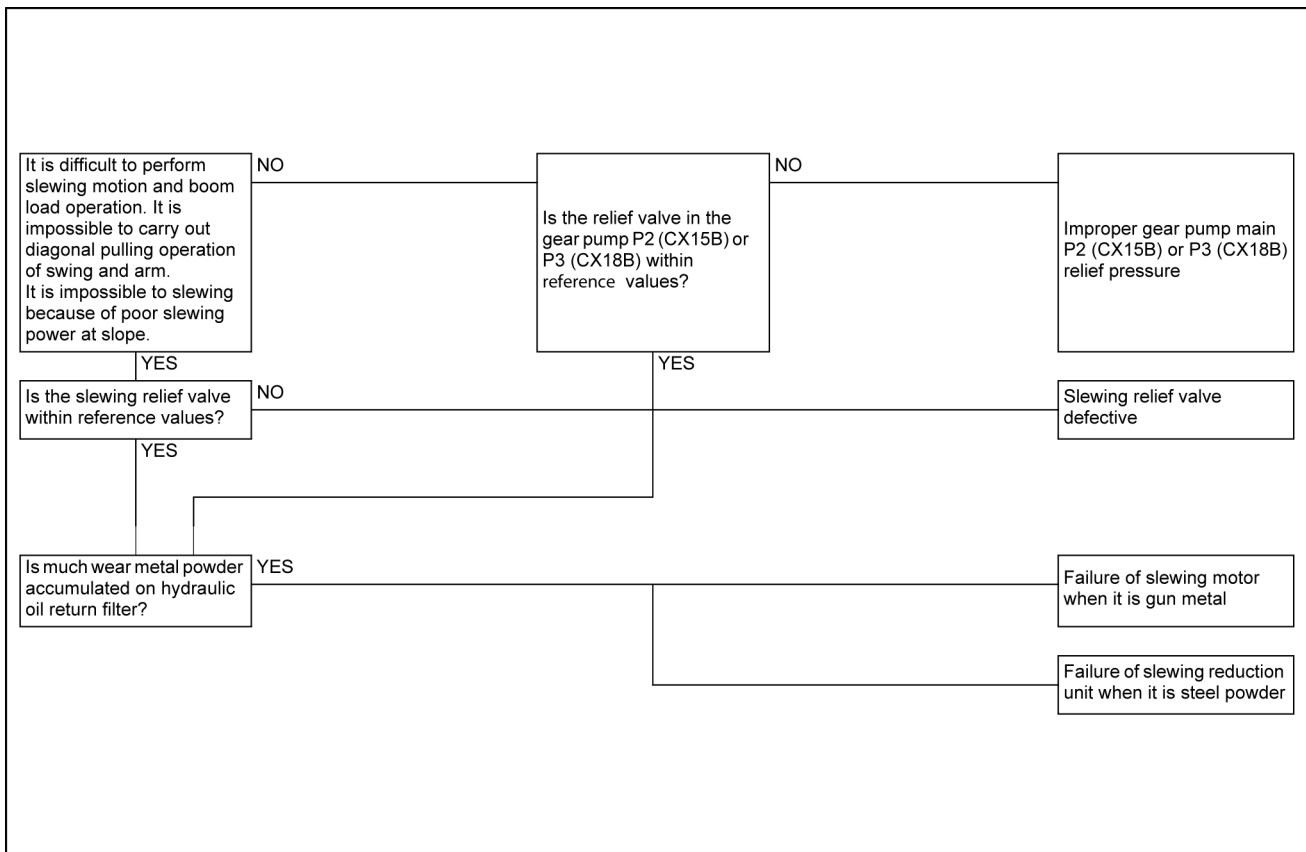

SMIL13MEX0374FA 15

Contents

Hydraulic systems - 35

Variable displacement pump - 106

TECHNICAL DATA

Pump

General specification - CX15B	3
General specification - CX18B	4

FUNCTIONAL DATA

Pump

Dynamic description - CX15B	5
Dynamic description - CX18B	7
Component identification - CX15B	9
Component identification - CX18B	10

SERVICE

Variable displacement pump

Remove	11
Install	13

Pump

Disassemble - CX15B	14
Disassemble - CX18B	18
Service instruction	22
Assemble - CX15B	23
Assemble - CX18B	27

DIAGNOSTIC

Pump

Troubleshooting	33
-----------------------	----

5. Disconnect the hydraulic lines (**CX18B**).

- Disconnect the hoses (**1**), (**2**) and (**3**) connecting the **P1**, **P2** and **P3** control valve ports.
- Loosen and remove the screws (**5**) with the relevant washers (**6**) to disconnect the tank connection hose (**4**).
- Plug all openings to prevent the penetration of dust or dirt.

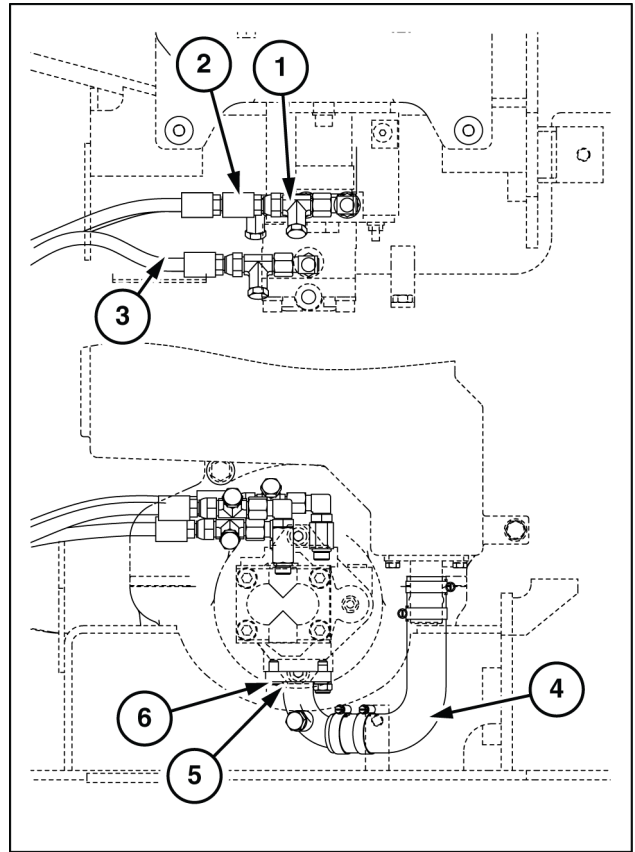

TULI12EXN2566BB 2

6. Loosen and remove the screws (**8**) with the relevant washers (**9**).

7. Remove the pump (**7**).

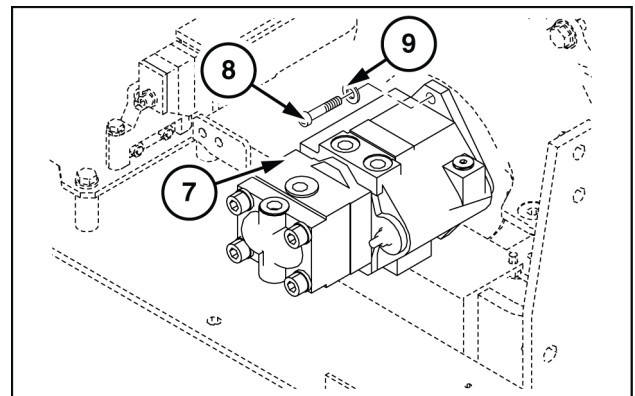

TULI12EXN2567AB 3

Pump - Service instruction

Maintenance standard

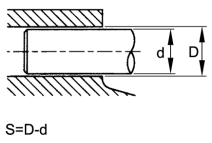
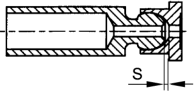
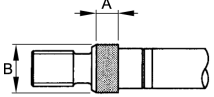
Part	Replacement criterion	Remedy
Piston and cylinder 	0.05 mm (0.002 in) or more tolerance "S" between piston and cylinder Defects, scratches and abnormal wear on sliding portion	Replace Replace
Clearance between piston and bottom 	0.2 mm (0.008 in) or more tolerance "S" between piston and seat	Replace
Oil seal installation area on the rod 	0.025 mm (0.001 in) or more wear on shaft at oil seal installation side	Replace

23. Place the O-rings (69), (71) & (72) on the installation side of the body H.

NOTE: Use new O-rings for assembling.

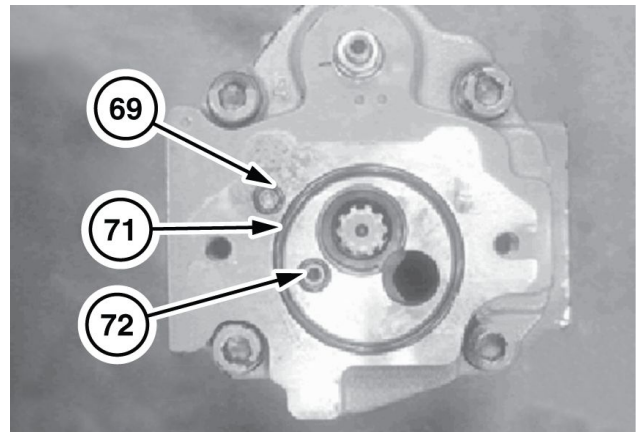

TUPH12EXN2849AB 21

24. Insert bushing (67) and sleeve (66).

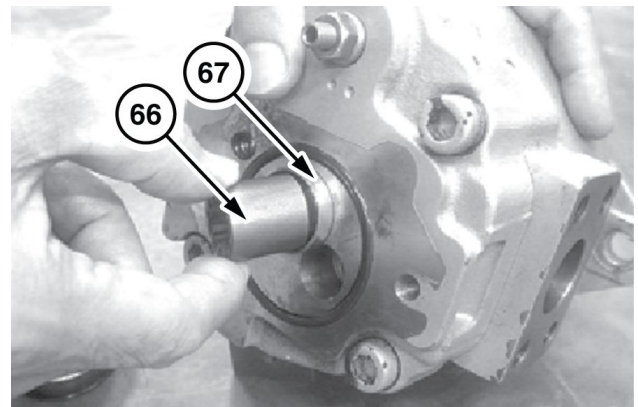

TUPH12EXN2850AB 22

25. Install the gear pump (65) and fix it by two screws (68) and the washers (70).
26. Tighten the screws to tightening torque of **19.6 - 23.5 N·m (14.5 - 17.3 lb ft)**.

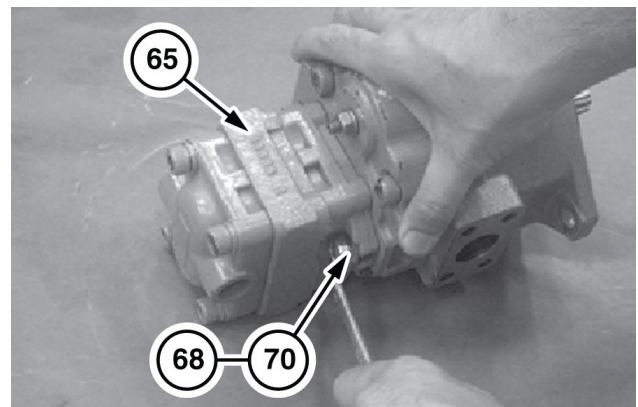

TUPH12EXN2851AB 23

27. After completed the assembling of pump, make sure that pump shaft rotates smoothly by hand.

Straight travel section

No.	Name	Qty.
1.	Body	1
2.	Spool	1
3.	Ball	1
4.	Plug	1
5.	Plug	2
6.	O-ring	2
7.	Spring	2
8.	Load check valve	2
9.	Filter housing	1
10.	O-ring	1
11.	Filter	2
12.	Ring stopper	1
13.	Spring	1
14.	Spring guide	1
15.	O-ring	2
16.	Cover	1
17.	Cover	1
18.	Screw	4
20.	Relief valve	2

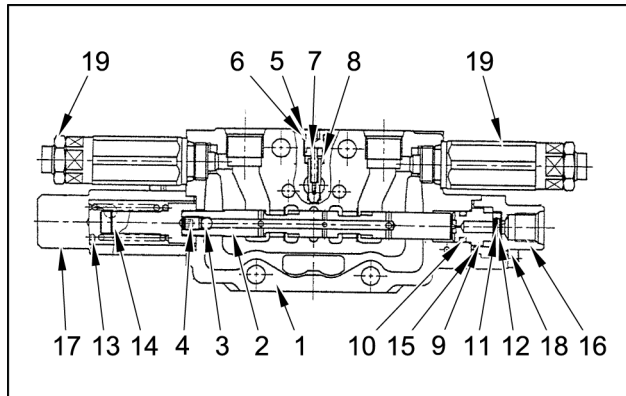

TUL12EXN2730AA 6

Dozer section

No.	Name	Qty.
1.	Body	1
2.	Spool	1
3.	O-ring	2
4.	Wiper ring	2
5.	Plate	2
6.	Spring seat	2
7.	Spring	1
8.	Spool terminal	1
9.	Needle	1
10.	Spring	1
11.	O-ring	1
12.	Spool	1
13.	Load check valve	1
14.	Spring	1
15.	O-ring	1
16.	Plug	1
17.	Screw	2
18.	Plug	1
19.	Screw	2
20.	Relief valve	1

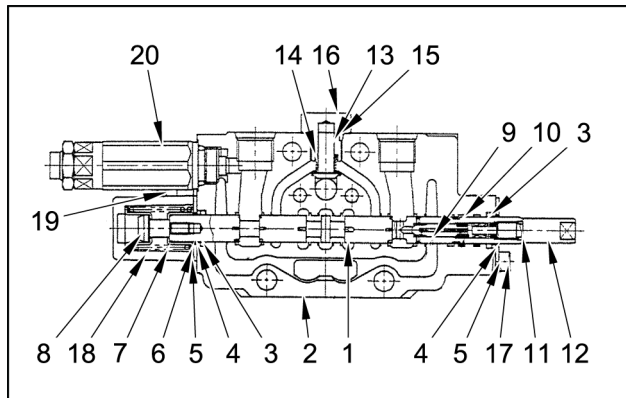

TUL12EXN2731AA 7

Stacked control valves - Hydraulic schema - CX18B

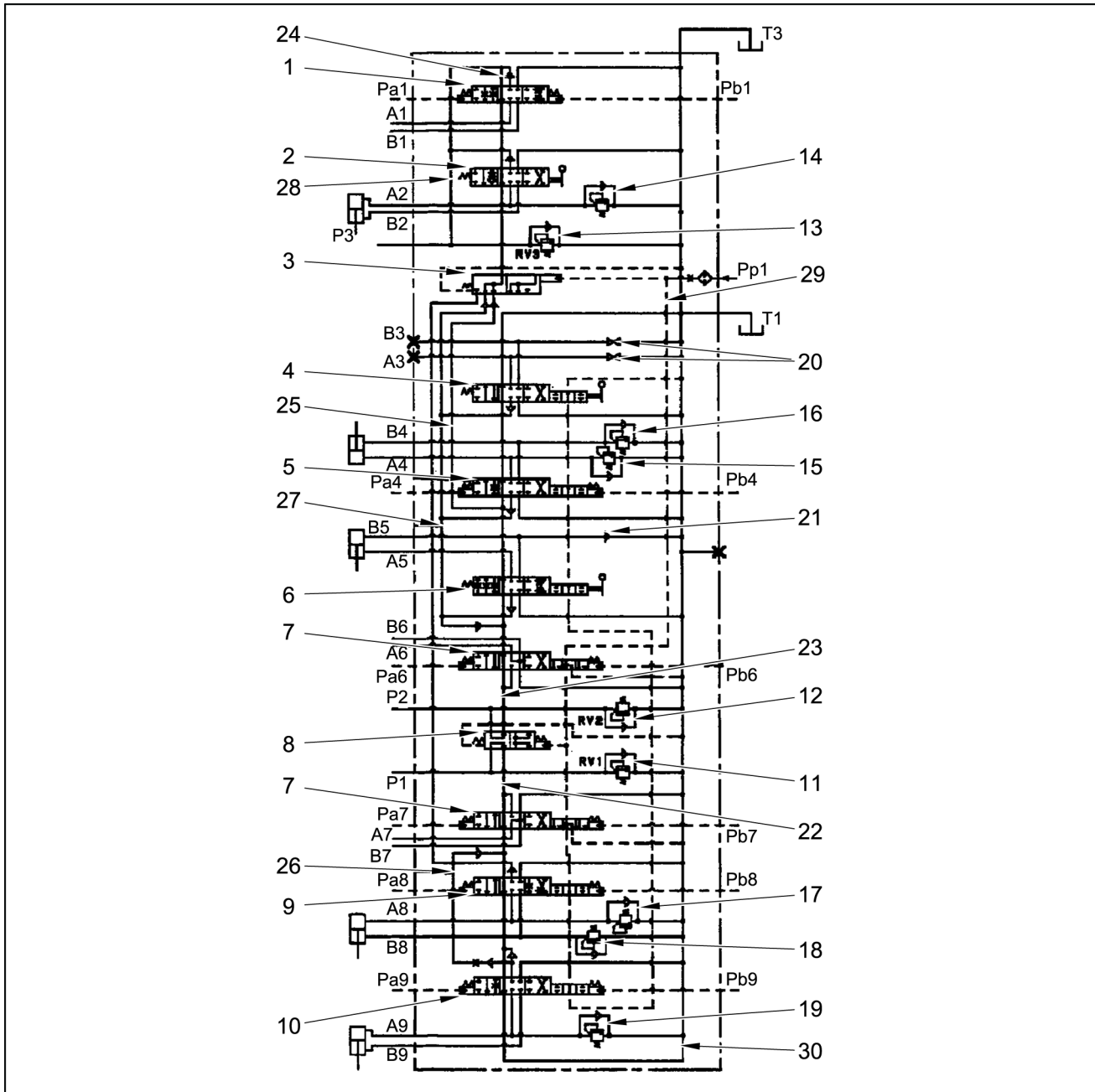

TULI12EXN2754GA 1

Relief valve operation

Operation with released pressure

The pressurized oil passes inside the piston (1) located in the setting device (2) and flows into the chamber (A) through the passage (B), thus enabling a correct positioning of the shutter (3) in its seat (4).

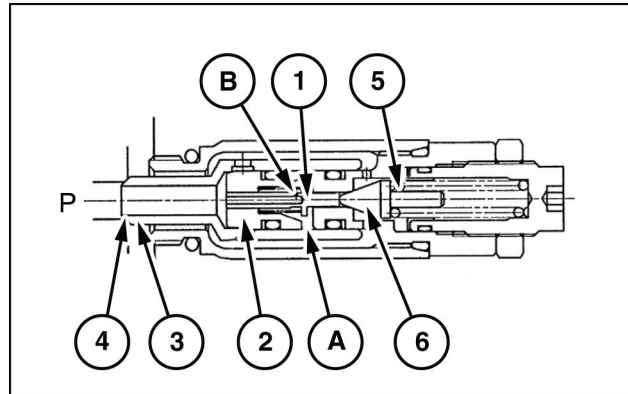

TULI12EXN2743AB 5

When the oil pressure in port (P) reaches the set pressure of the spring (5), the pressurized oil acts on the needle (6) in the piston (1) and opens it. Then, the pressurized oil flows inside the piston, in this order: passage (B), chamber (A), ring passage, passage (D), and flows out towards the tank around the shutter (3).

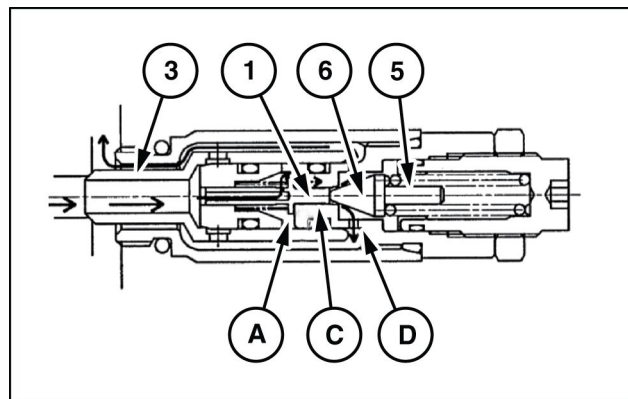

TULI12EXN2744AB 6

The pressure in chamber (A) drops because the needle (6) is open; consequently, the pressurized oil in port (P) flows out to the tank through passage (E).

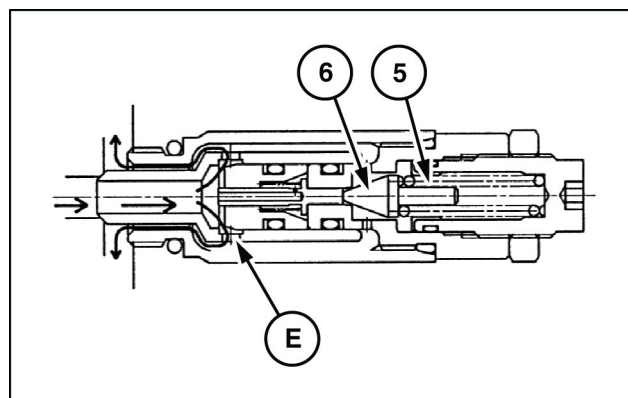

TULI12EXN2745AB 7

When the pressure in port (P) drops below the pressure set by the spring (5) in the needle (6), the needle is pushed against the seat by the spring force (5) and the pressure in chamber (A) becomes equal to the pressure in port (P); consequently, the needle (6) is also pushed against its seat and returns to the former condition.

Independent travel operation

When any one of the bucket, the swing, the arm and the service is switched with both left and right travels switched, the oil having entered the independent travel passage through the orifice from the **Pp1** port allows the signal passage pressure to be equal to the **Pp1** port supply pressure because the independent travel passage and the tank passage are blocked from each other.

Consequently, the independent travel spool receives the **Pp1** port supply pressure to move against the spring force until it comes in contact with the pilot lid.

In response to the shift of the independent travel spool, the oil supplied from the **P3** port passes through the parallel passages and by-pass passages in the slewing and dozer switching sections, then through the spool in the **P3** supply section and the land portion in the main body, and finally flows into the **P1** and **P2** side parallel passages.

These switching actions allow pressurized oil supplied to the **P1** and **P2** ports to actuate the left and right travels respectively, and that supplied to the **P3** port to actuate the other attachments.

Thus, you can simultaneously operate left and right travels and the other attachments.

Moreover, in any of the independent travel conditions mentioned above (switching any one of left and right travels and switching of boom, bucket, swing, arm, and service), the communication valve spools for the **P1** and **P2** supply ports are shifted simultaneously.

Therefore, **P1** and **P2** communicate with each other to ensure straight travelling even in an operating condition with, for example, any one of travel lever half shift and switching of boom, bucket, swing, arm, and service switched.

CLICK HERE TO **DOWNLOAD** THE COMPLETE MANUAL

- Thank you very much for reading the preview of the manual.
- You can download the complete manual from: www.heydownloads.com by clicking the link below



- Please note: If there is no response to CLICKING the link, please download this PDF first and then click on it.

CLICK HERE TO **DOWNLOAD** THE COMPLETE MANUAL

Removal of the straight travel section spool

1. Firstly, loosen and remove the screws (15).
2. Remove the cover (13).
3. Remove the spring (11) and the spring seat (18). And draw out and take out the spool (2) slightly and horizontally (parallel to the spool hole) from the body (1) by holding the end of the spool (2).
4. At this time, ensure that the O-ring (12) in the bottom of the flange installing the cover on the main body side is in place without coming off.
5. Further loosen opposite side the screws (15) and remove cover and the filter case (A) assembly.
6. At this time, ensure that the O-ring (12) in the bottom of the flange installing the cover on the main body side is in place without coming off.

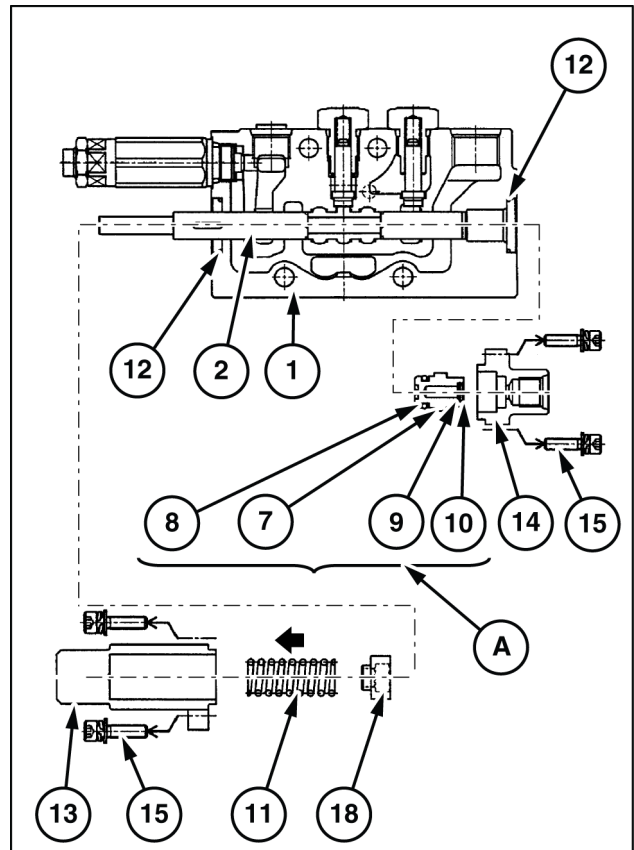

TULI12EXN2859BB 3

Valve disassembly

Pressure relief valves

1. First of all, place the control valve on a workbench and make sure that it is properly blocked. Then remove the valve by applying the wrench on the valve body. The valve should not be removed by applying the wrench to the adjusting nuts. The calibration of each valve differs according to its use, therefore mark all valves and their relevant mounting places. Handle disassembled valves with care so as not to damage their mating faces.
2. The pressure relief valves are vital for the performance and the safety of the machine, we advice you not to disassemble them, but if a fault is found, replace the valve assy.
3. If nevertheless a valve has to be disassembled, observe following procedure.
4. Lock the valve into a vice by clamping the hexagonal section of the body (5). Loosen and remove the nut (8) with the adjusting screw (7).
5. Take out spring (9), poppet (6) and spring guide (16).
6. Loosen and remove the plug (4) and extract the piston (3), the spring (10), the pressure regulator (3) and the shutter (1).

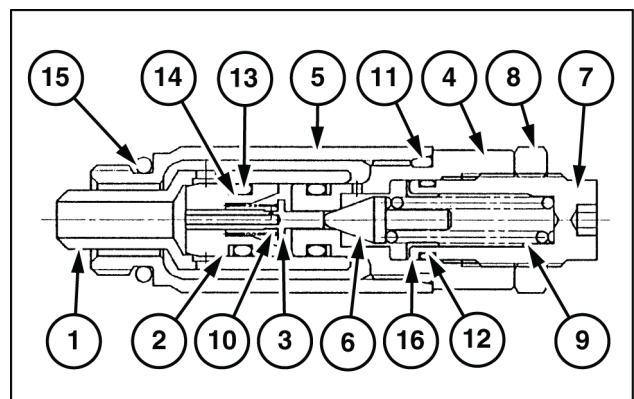

TULI12EXN2860AB 4

Hand control - Component identification

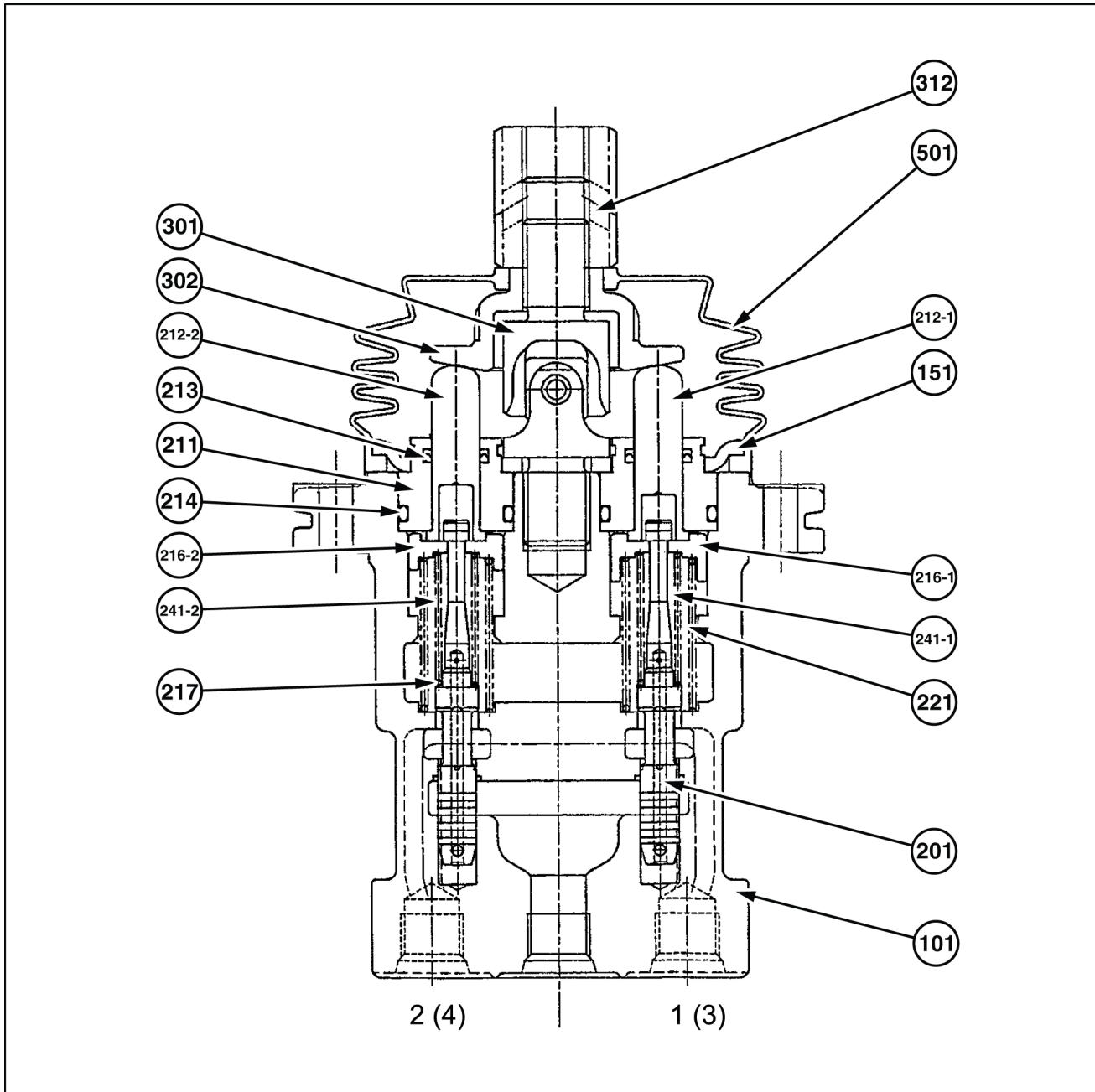

TULI12EXN2712GB 1

No.	Name	Qty.	No.	Name	Qty.
101.	Body	1	217.	Washer	4
151.	Plate	1	221.	Spring	4
201.	Spool	4	241-1.	Spring	2
212-1.	Pusher	2	241-2.	Spring	2
212-2.	Pusher	2	301.	Joint	1
213.	Gasket	4	302.	Disc	1
214.	O-ring	4	312.	Nut	1
216-1.	Spring seat	2	501.	Boot	1
216-2.	Spring seat	2			

11. If spring return is too strong, install four plugs simultaneously using the plate (151) and temporarily fasten them with the joint (301).

NOTICE: Be careful to popping up of the plug assembly and plate (151).

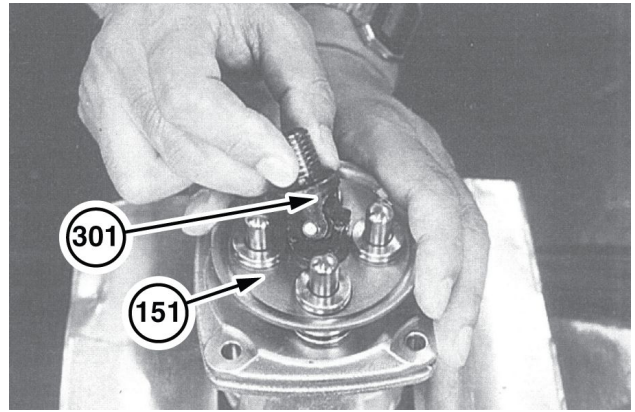

TUPH12EXN2879AB 8

12. Install the plate (151).
13. Install the joint into the valve body (101).

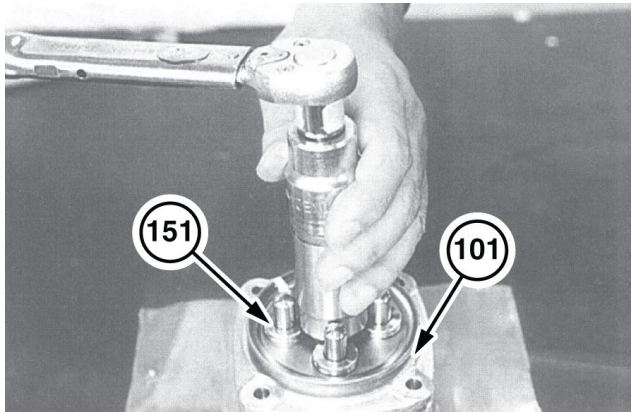

TUPH12EXN2880AB 9

14. Install the disc (302). Screw and tighten the nut (312) by holding the disc (302) with a wrench. Do not change the position of the disc (302) during tightening.

NOTICE: Screw in until the disc contacts with four push rods equally.

Carefully adjust the screwing position of the disc (302) because excessive screwing may result in secondary pressure generation at the neutral position of the lever, leading to malfunction of the actual machine.

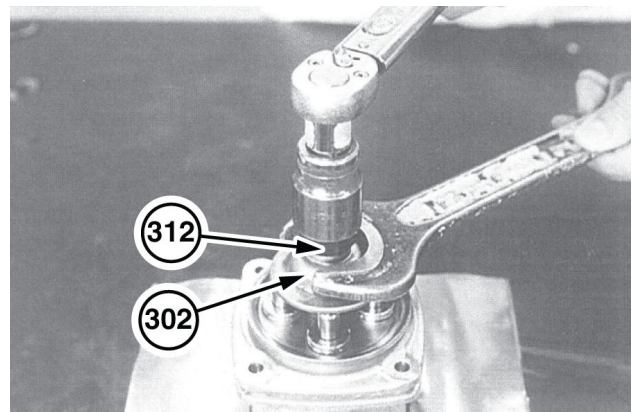

TUPH12EXN2881AB 10

15. Apply grease to the rotating section of the joint (301) and of the push rod (212).

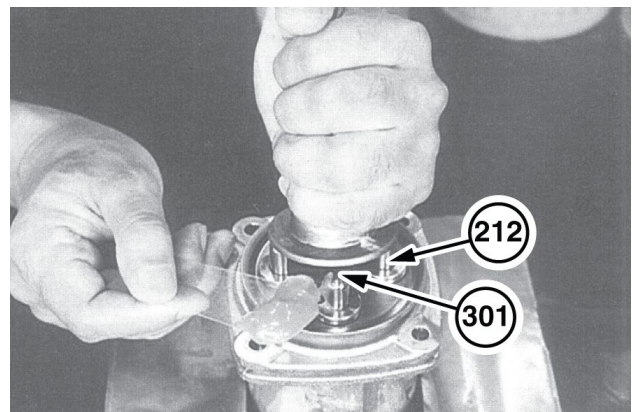

TUPH12EXN2882AB 11

Lever in tilted position

By rotating the cam (420) clockwise, the pusher (214) on port 1 side is pushed downwards, and consequently the spool also moves towards the spring seat (311), the spring (324) to adjust the secondary pressure, the shim (217) and the washer (313) and consequently port P is connected to port 1 and the oil delivered by the pilot pump flows into port 1 and generates pressure.

When pressure at port 1 increases up to a value equal to that of the pressure of the spring for the adjustment of the secondary pressure, set by the angle of the control section, the hydraulic pressure applied to the spool balances the spring force and keeps port 1 to a constant delivery pressure.

The spool of the port 2 side remains in neutral position, and the return oil from the control valve is discharged through port T.

- A. Neutral position
- B. Full stroke

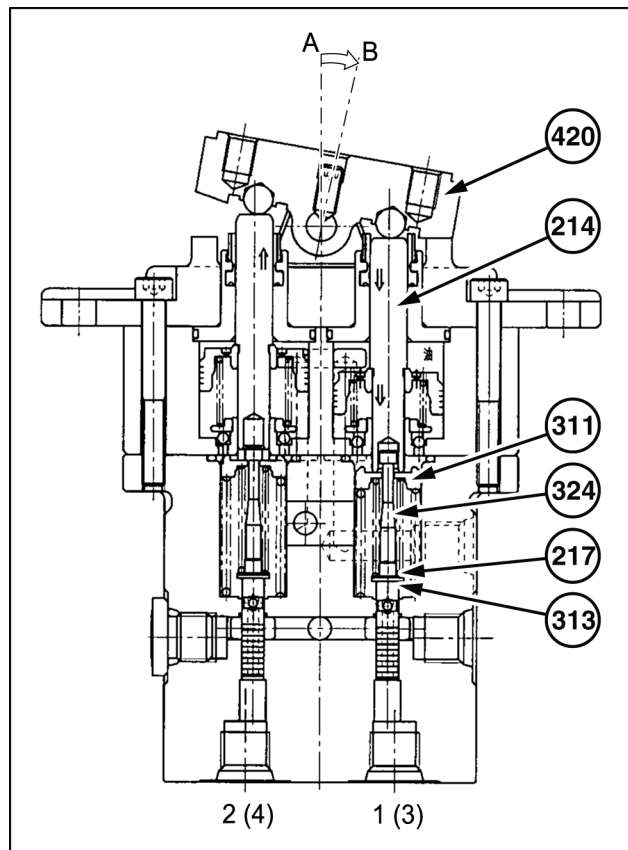

Damping mechanism

In neutral position, the tappet rod (214) is pushed by the spring (336) through the piston (224) and blocks in the position shown in the Fig. 3.

When the control section is tilted with respect to the neutral position, by rotating the cam clockwise, the tappet rod on the side of port 1 is pushed downwards, as well as the piston.

Then, the oil in the piston chamber is drained through the opening, and the pressure generated in this moment produces a damping force.

On the other side, the pusher on the port 2 side moves upwards, releasing the spring through the piston.

Then, oil is sucked from the tank into the piston chamber through three ball check valves. The oil outside the piston chamber flows through the passage leading to port T on the upper side.

- A. When moving from the neutral position towards the direction P, the oil in the piston chamber on the right (left) side is drained through passage (C), and the pressure generated at the same time produces the damping force.

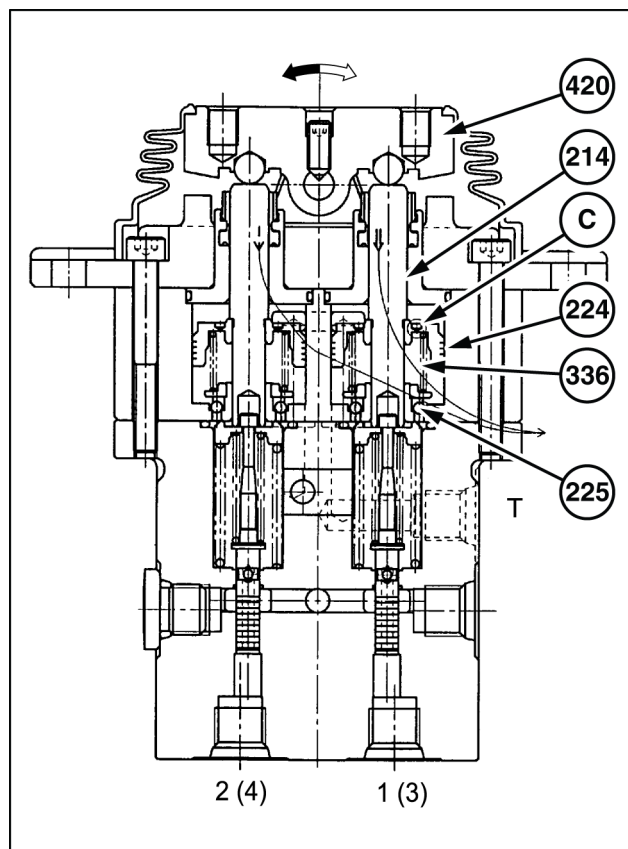

Contents

Hydraulic systems - 35

Hydraulic swing system - 352

TECHNICAL DATA

Hydraulic swing system	
General specification	3

FUNCTIONAL DATA

Hydraulic swing system	
Component identification	4
Dynamic description	6

SERVICE

Hydraulic swing system	
Remove	9
Install	10
Disassemble	11
Pre-assemble	16
Assemble	17
Service instruction	25

11. Take out the pins (214) and (225) from the body (202).

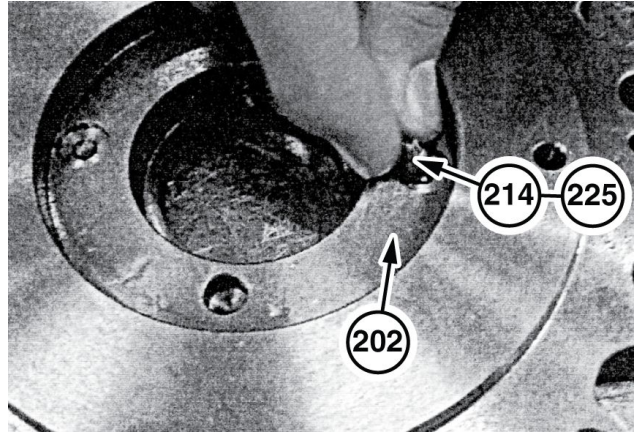

TUPH12EXN2890AB 4

12. Take out the O-ring (218) and the cylinder (204) assy. from the body H (201).

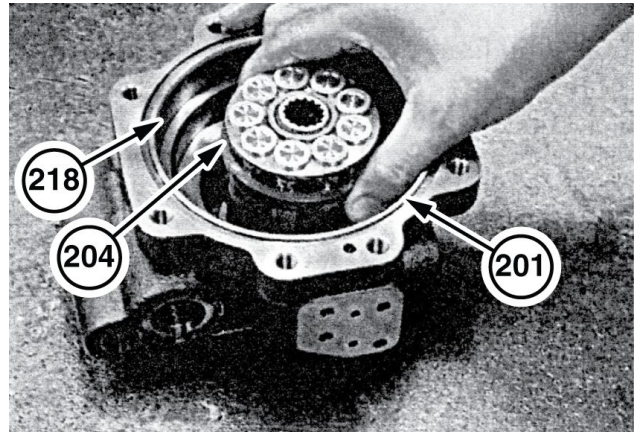

TUPH12EXN2891AB 5

13. Remove the pistons (206) with their seats (207), the piston disc (208), the link (209) and the pin (213) from the cylinder (204).

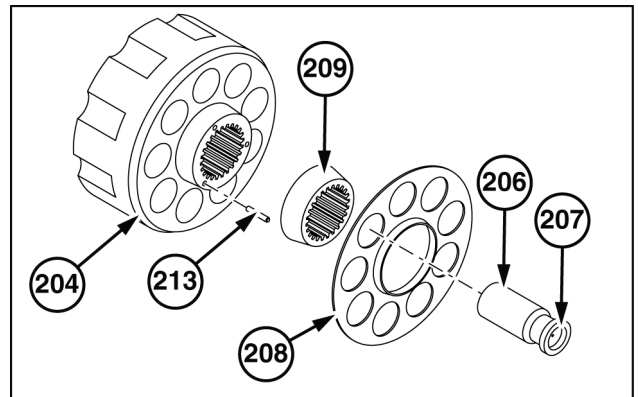

TULI12EXN2892AB 6

8. Turn over the body (101), then press-fit the bearing (102).

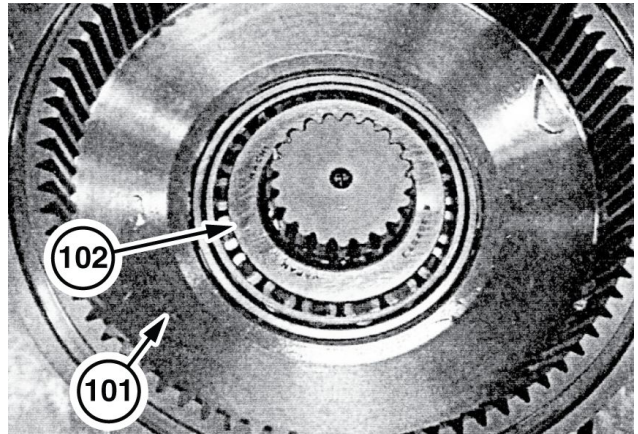

TUPH12EXN3225AB 19

9. Insert the spacer (119).

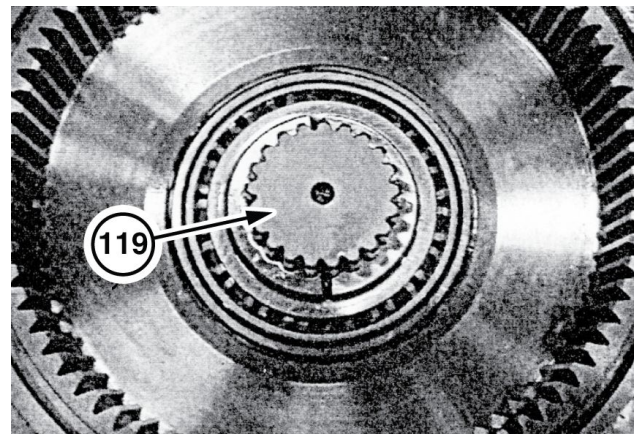

TUPH12EXN3226AB 20

NOTE: Thickness of spacer must be adjusted for the below "L" dimension.
Standard 0 - 0.05 mm (0 - 0.002 in).

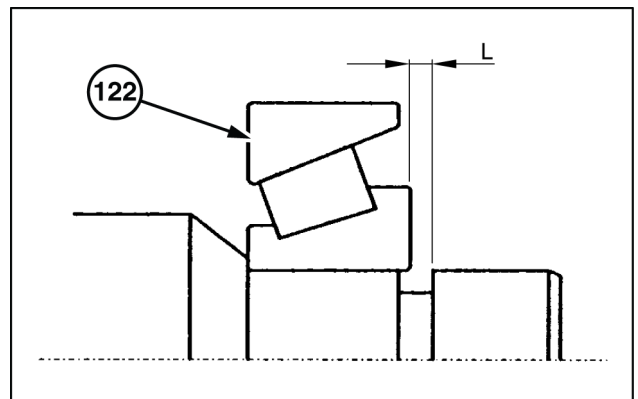

TULI12EXN3227AB 21

10. Install the ring (128).

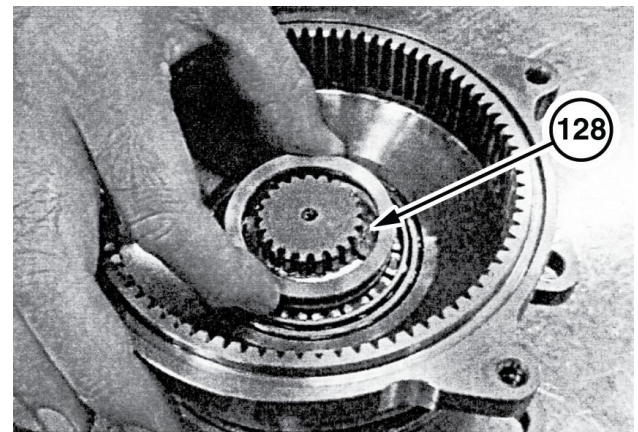

TUPH12EXN3228AB 22

Hydraulic travel system - Component identification - One speed models

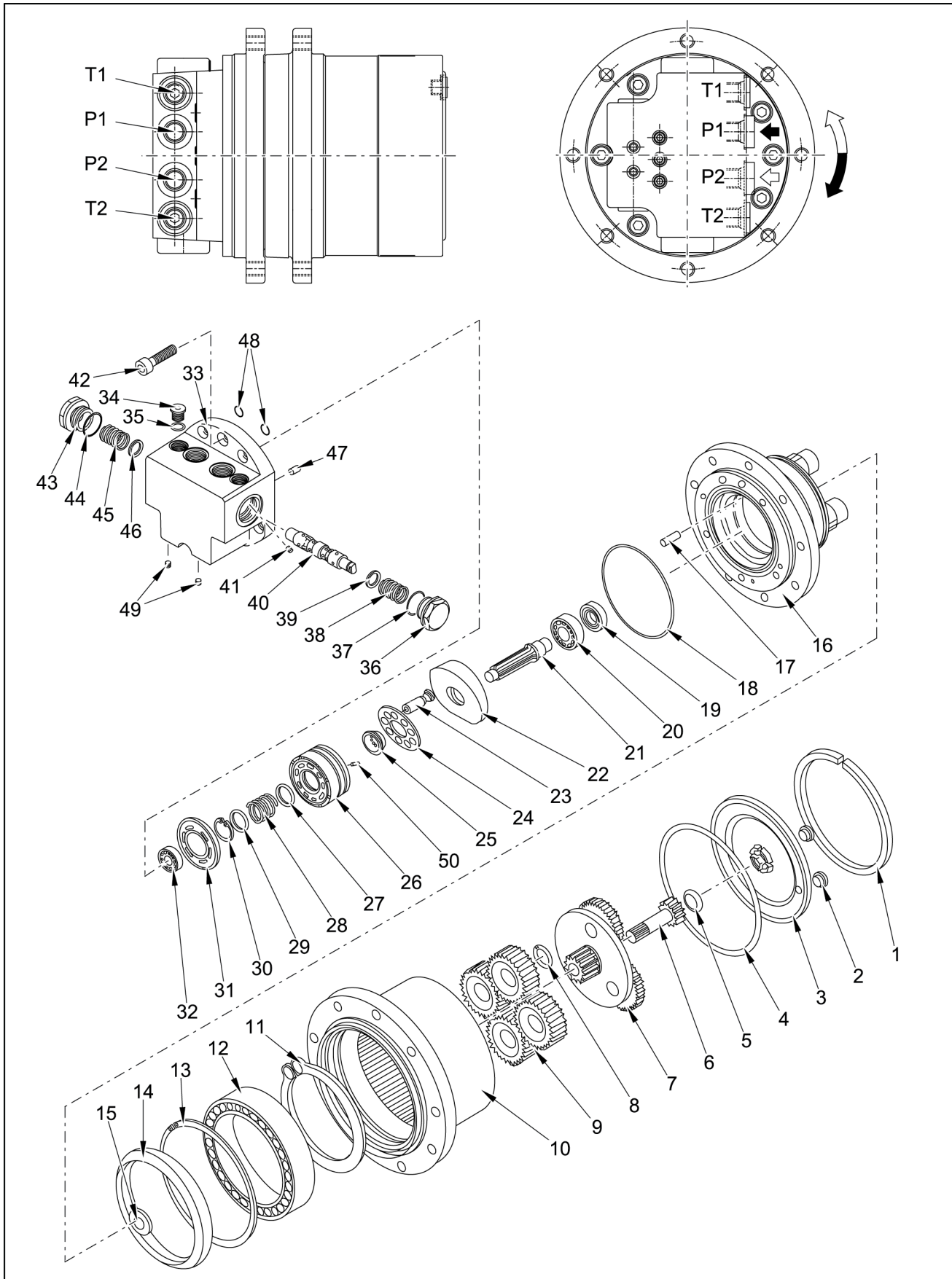

TULI12EXN3001HA 1

Hydraulic travel system - Disassemble

1. Loosen and remove the plugs (2) from the cover (3) and completely drain the oil.

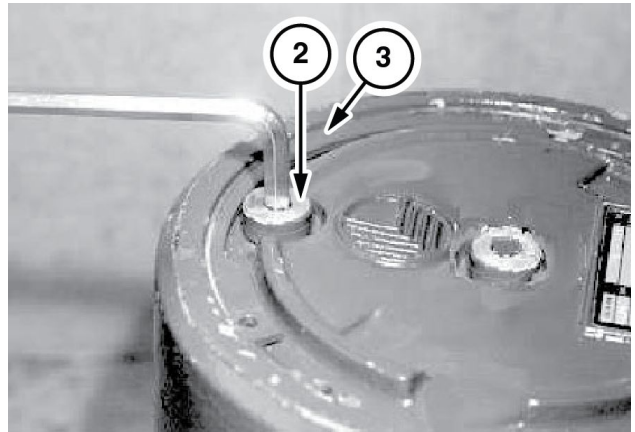

TUPH12EXN3003AB 1

2. Remove the snap ring (1) using pliers.

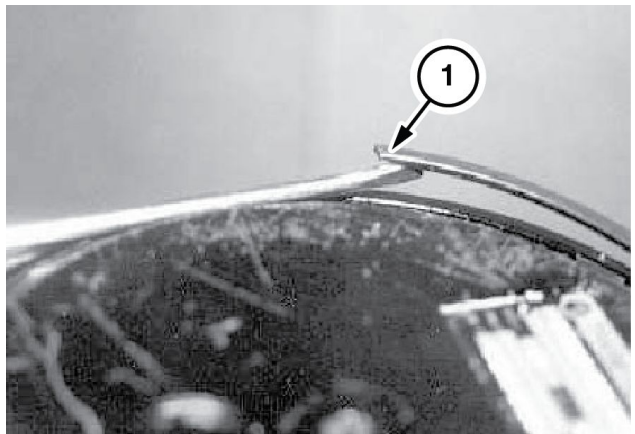

TUPH12EXN3004AB 2

3. Position the wrench in the plug seat (2), lift and remove the cover (3).



TUPH12EXN3005AB 3

36. Extract the spool of the braking valve (53) from the opposite side to extract the second ring too.

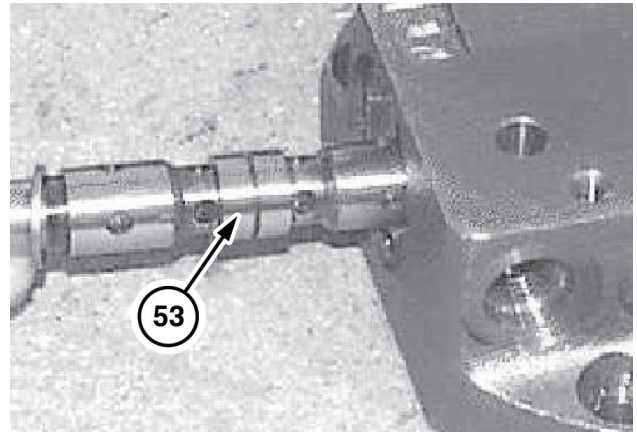

TUPH12EXN3040AB 38

37. Extract the ring (43) from the spool of the braking valve (53).

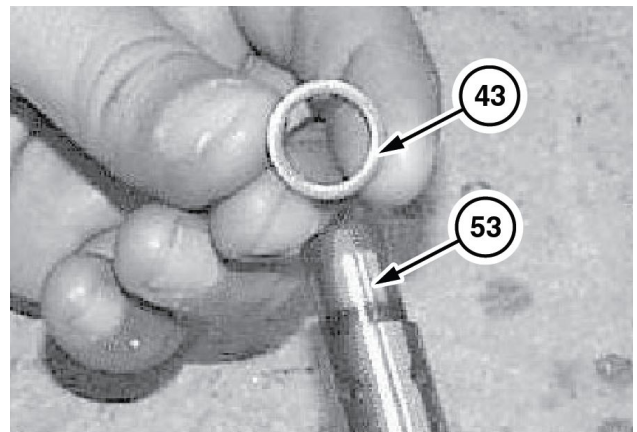

TUPH12EXN3041AB 39

38. Loosen and remove the restrictors (62).

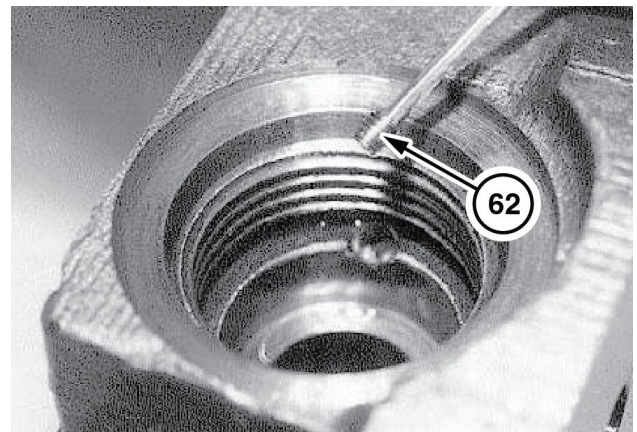

TUPH12EXN3042AB 40

39. Remove the O-ring (21).



TUPH12EXN3043AB 41

17. Fit the O-ring (21).

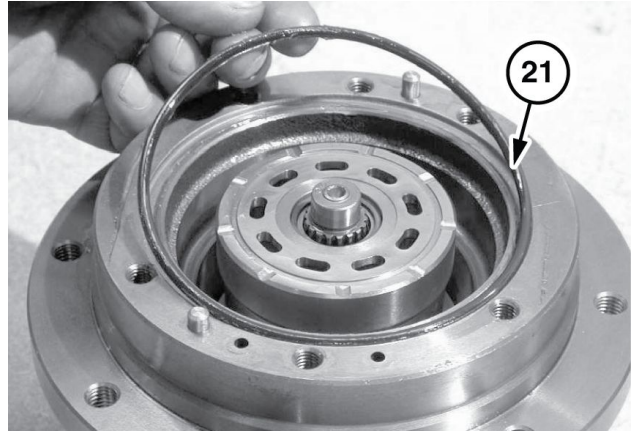

TUPH12EXN3260AB 19

18. Insert the 2 restrictors (62) into the engine head and tighten to a torque of 1 - 2 N·m (0.74 - 1.48 lb ft). Caulk the thread with a punch.

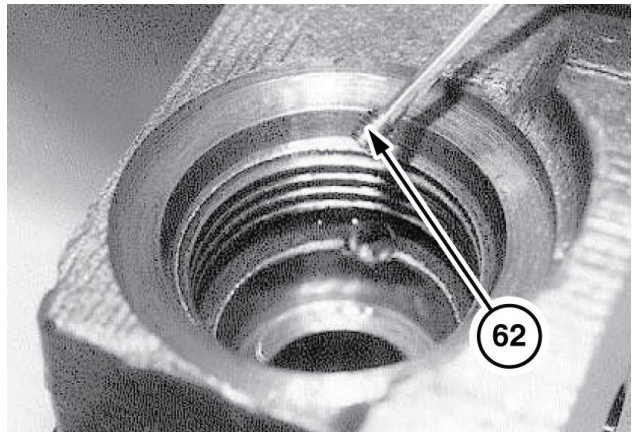

TUPH12EXN3261AB 20

19. Insert the first ring (43) onto the spool of the braking valve (53).

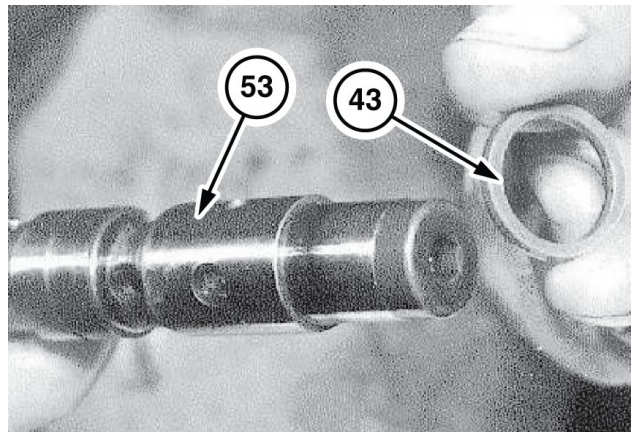

TUPH12EXN3262AB 21

20. Insert the braking valve spool (43).

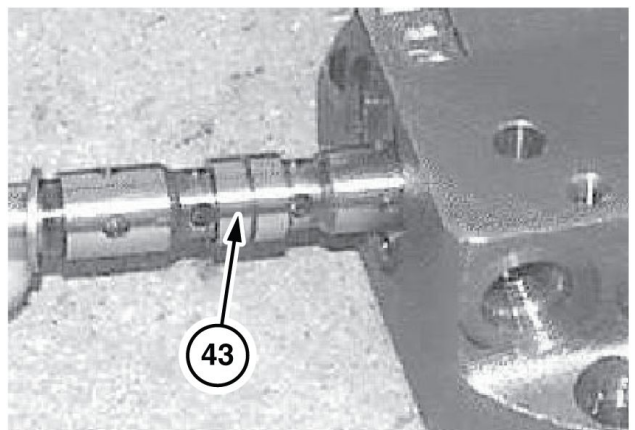

TUPH12EXN3263AB 22

55. Assemble the elastic ring (11).

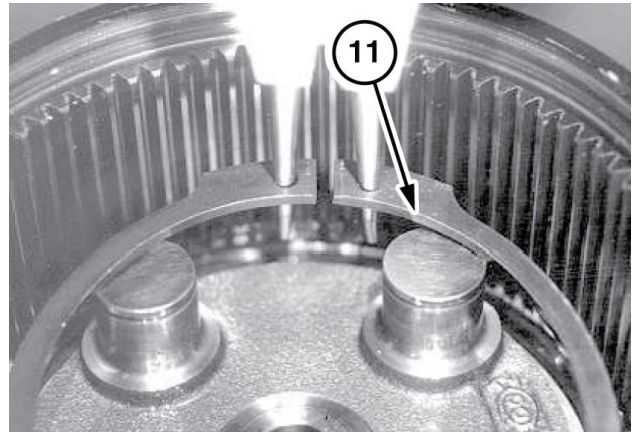

TUPH12EXN3299AB 58

56. Correctly position the planetary gears (9).

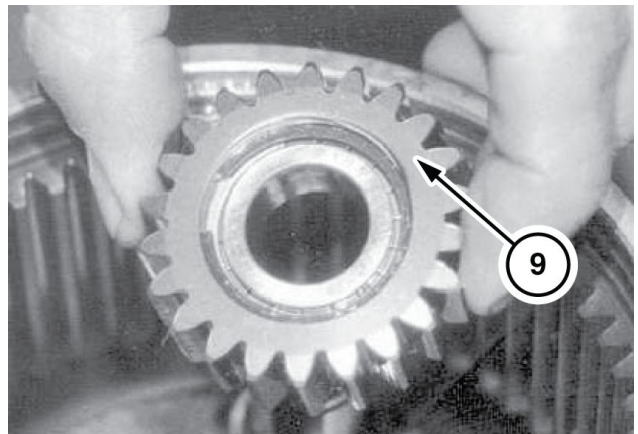

TUPH12EXN3300AB 59

57. Using a press and a pad, completely push in the planetary gears on the pins.

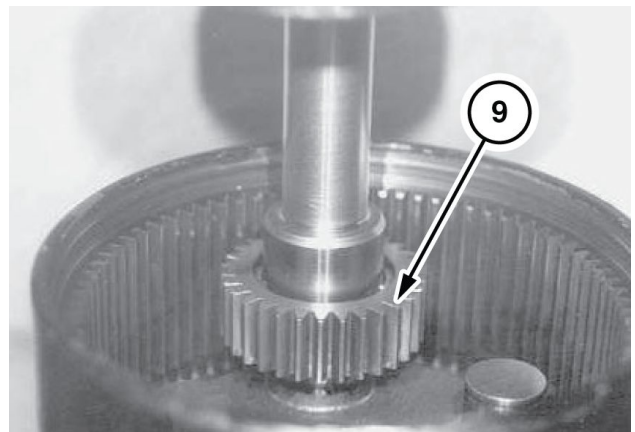

TUPH12EXN3530AB 60

58. Assemble the elastic rings (8).

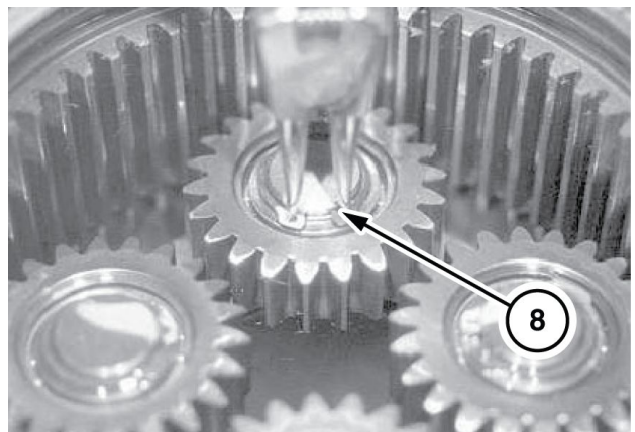

TUPH12EXN3531AB 61

Hydraulic swivel - Component identification - CX18B

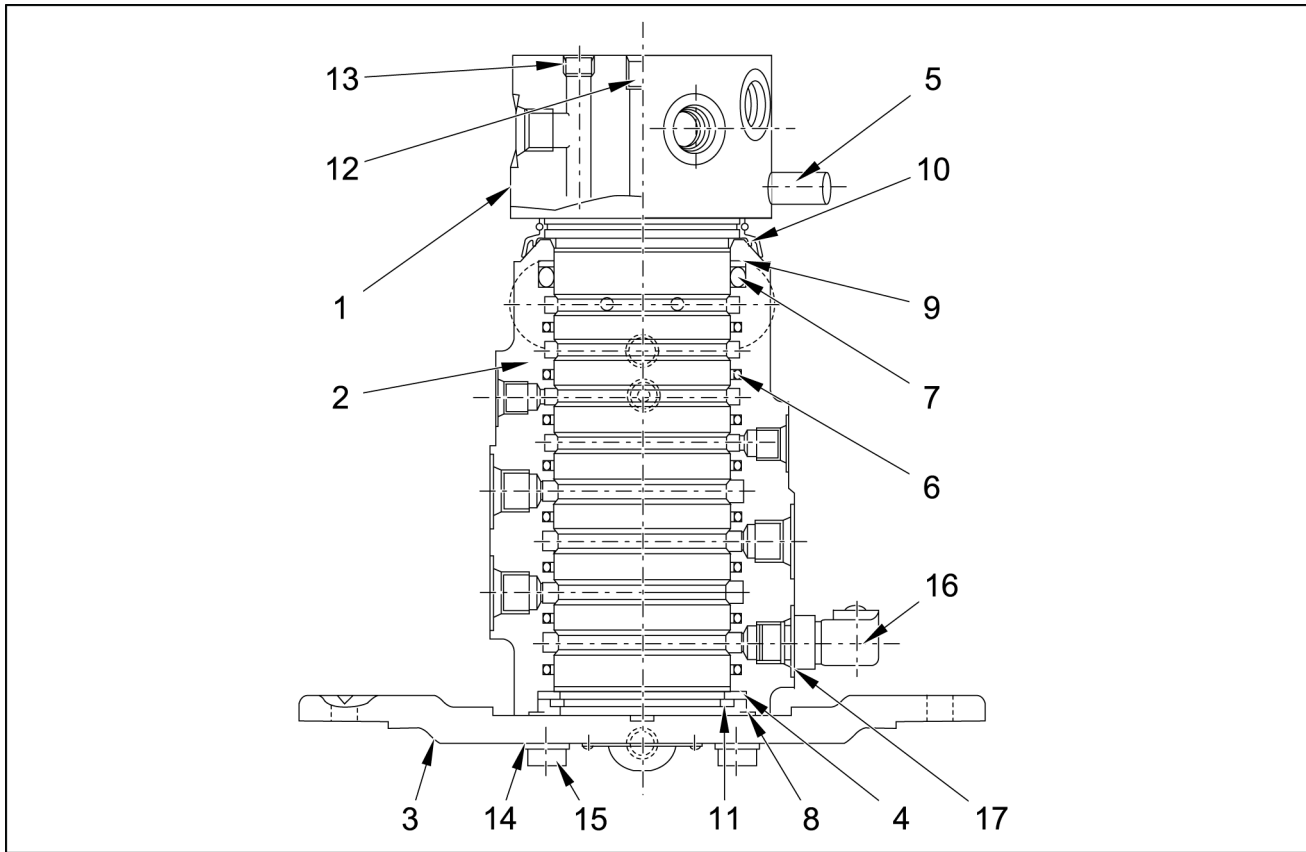

TULI12EXN2787FA 1

No.	Name	Qty.	No.	Name	Qty.
1.	Shaft	1	10.	External gasket	1
2.	Body	1	11.	Elastic ring	1
3.	Flange	1	12.	Plug	2
4.	Ring	1	13.	Plug	4
5.	Pin	1	14.	Screw	4
6.	Gasket	7	15.	Washer	4
7.	O-ring	1	16.	Fitting	1
8.	O-ring	1	17.	O-ring	1
9.	Back-up ring	1			

Hydraulic swivel - Inspect

After assembly is completed, check each circuit for leakage of oil, using the equipment shown below.

- Connect a pipe (3) between the hydraulic pump (4) and the shaft (1) side port.
- Connect a pressure gauge (5) to the body (2).
- Increase the pressure gradually to **210 Kg/cm² (2987 psi)** adjusting the relief valve (6), then perform **1 min** leak test.
- Open the neighboring ports on both sides of the body and visually check for leaks from the ports.
- Check for external leaks through a colour check.

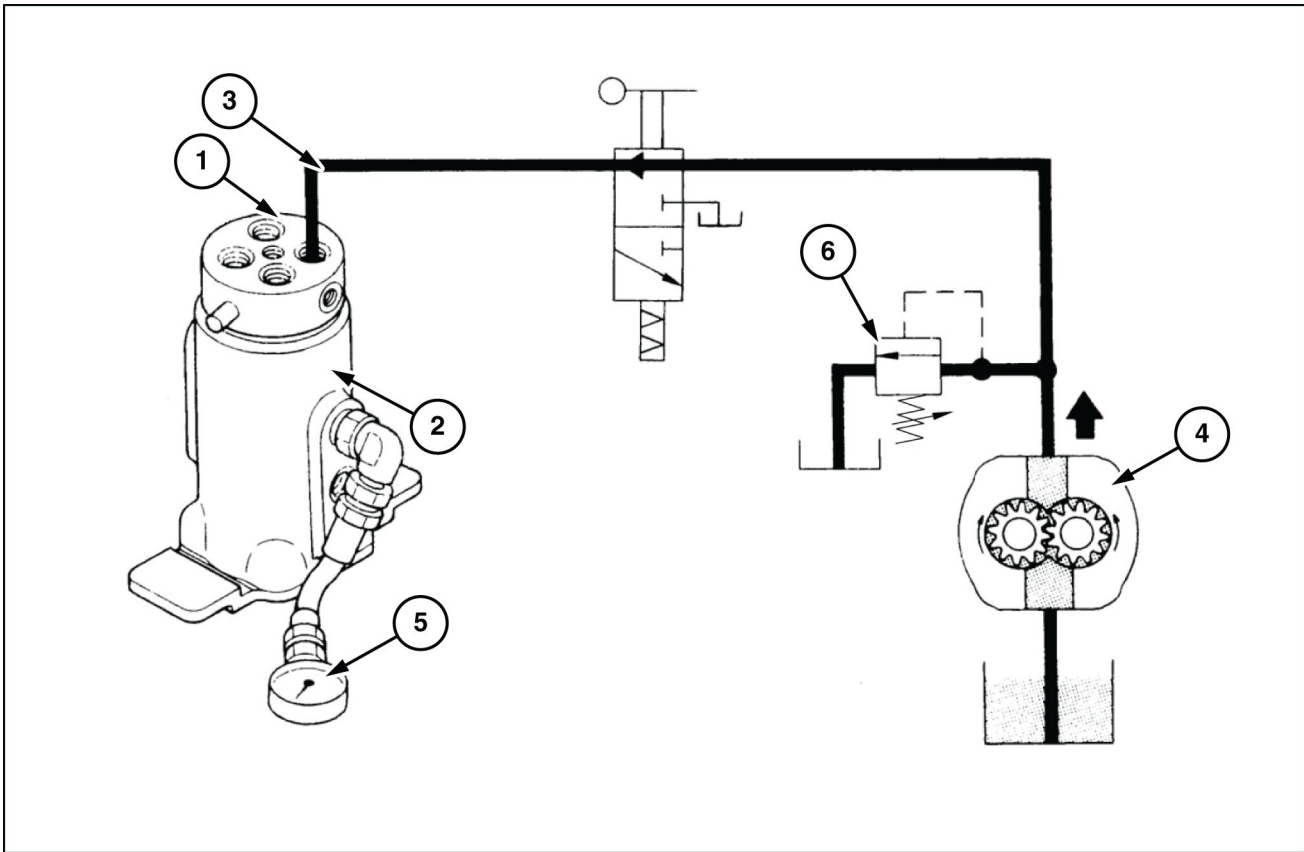

TULI12EXN3237FB 1

- | | |
|----------|-------------------|
| 1. Shaft | 4. Hydraulic pump |
| 2. Body | 5. Pressure gauge |
| 3. Hose | 6. Relief valve |

Track frame widening system - Dynamic description - Selector valve on CX18B model

By operation of the selector valve, shifting for operation of dozer blade cylinder and crawler frame width cylinder is done.

When spool (2) of the selector valve (1) is on the left side, port P of the selector valve (1) is connected to port E of the swivel joint. Owing to the above, oil from the control valve flow to the dozer blade cylinder.

When the spool (2) of the selector valve (1) shifts to right side, port P of the selector valve (1) is connected to port G of the swivel joint. Owing to the above oil from the control valve flow to the crawler frame width cylinder.

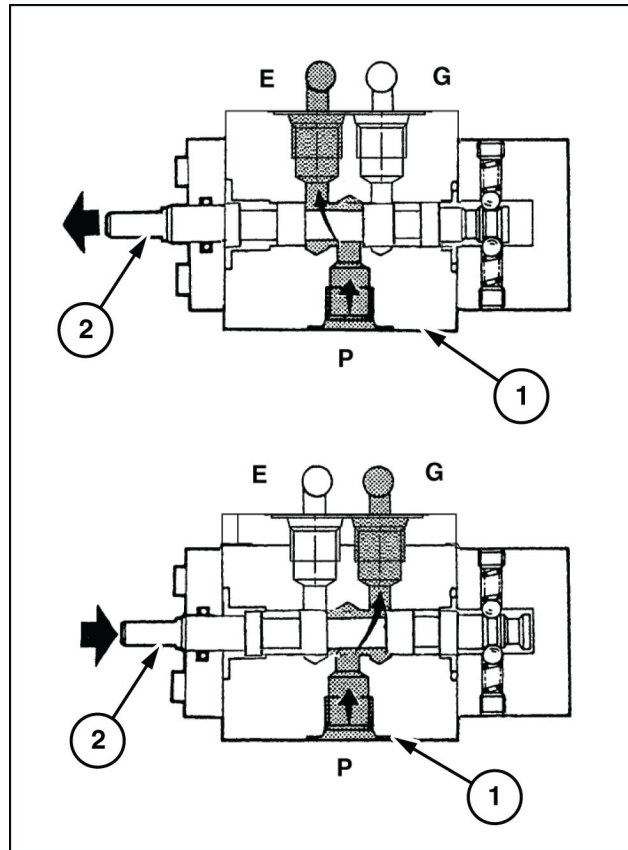

TULI12EXN2789BB 1

Boom cylinder - Component identification

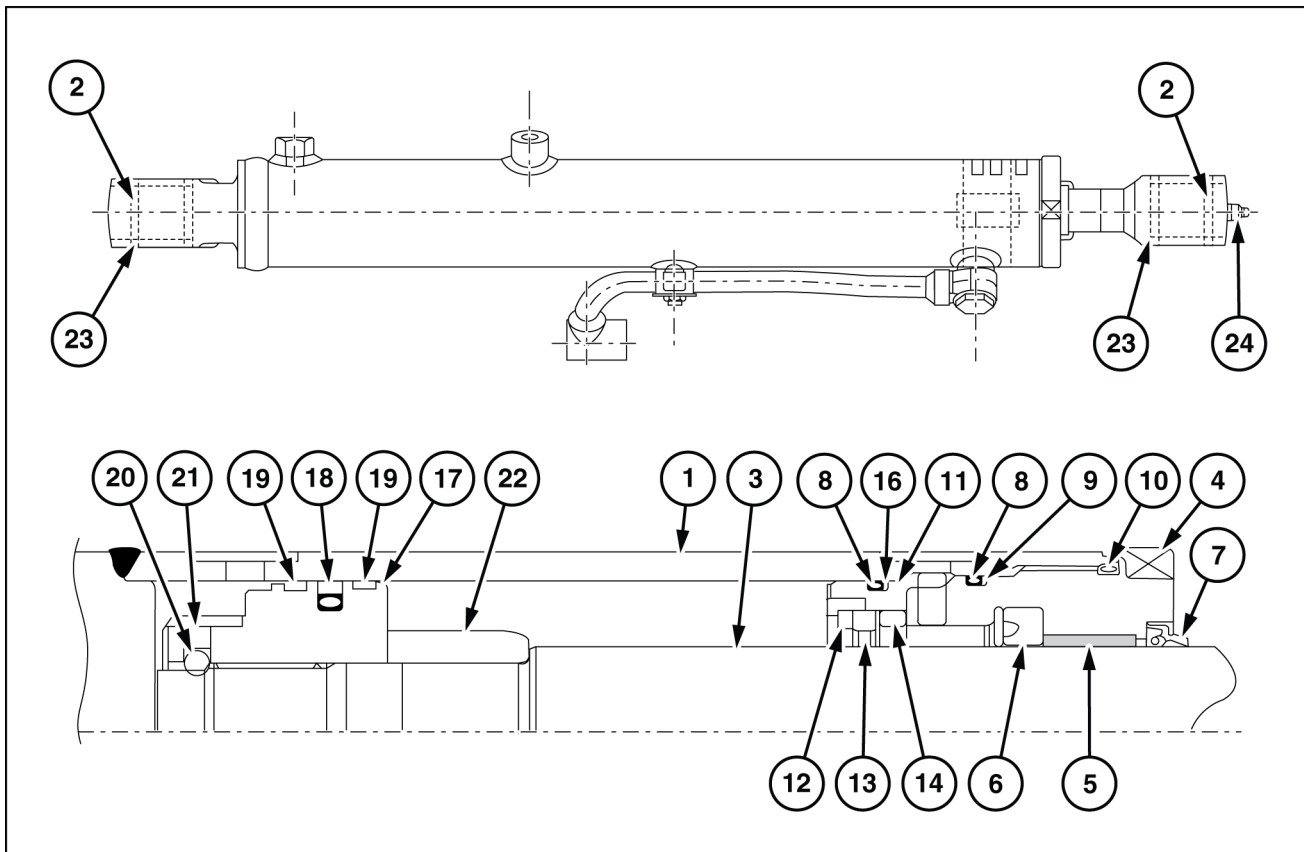

TULI12EXN2792FB 1

No.	Name	Qty.	No.	Name	Qty.
1.	Cylinder liner	1	13.	Seal ring	1
2.	Bushing	2	14.	Collar	1
3.	Rod	1	16.	Back-up ring	1
4.	Cylinder head	1	17.	Piston	1
5.	Guide bushing	1	18.	Piston gasket	1
6.	Seal ring	1	19.	Piston guide ring	2
7.	Wiper ring	1	20.	Dowel	1
8.	O-ring	2	21.	Ball	1
9.	Back-up ring	1	22.	Bushing	1
10.	O-ring	1	23.	Dust wiper ring	4
11.	Bracket	1	24.	Grease cup	2
12.	Spacer	1			

11. Insert the piston assembly (17) into the cylinder rod (3). Tighten to the prescribed torque and lock it by inserting the ball (21) and the dowel (20). (For the boom cylinder, before inserting the piston into the rod, assemble the bushing (22)).

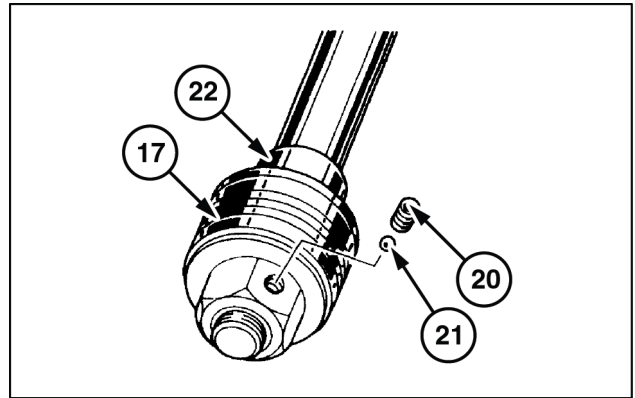

TULI12EXN2914AB 13

12. Insert the cylinder rod (3) complete with piston and head into the cylinder liner (1). Take care to insert the rod in a linear way and not to damage the gaskets.

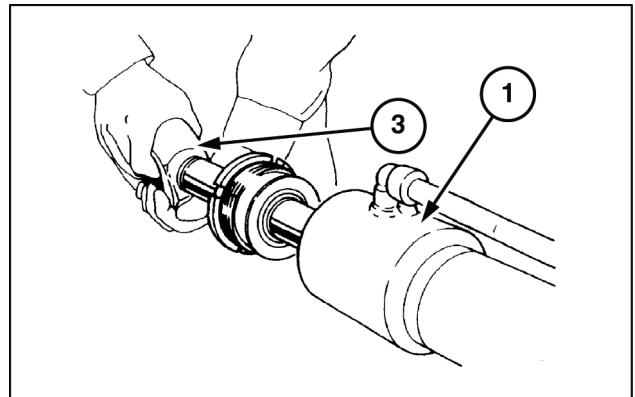

TULI12EXN2915AB 14

13. Tighten the cylinder head (4) to the prescribed torque.

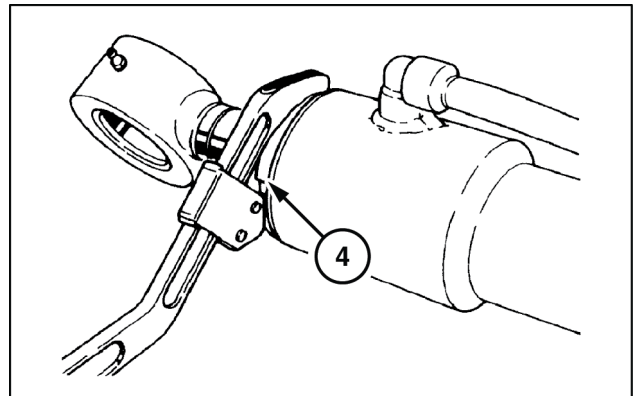

TULI12EXN2916AB 15

14. Fold the lock fin onto the cylinder liner (7) and lock the cylinder head (4).

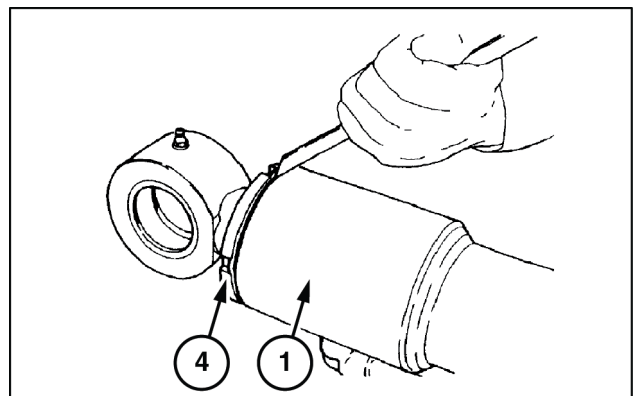

TULI12EXN2917AB 16

Dipper cylinder - Component identification

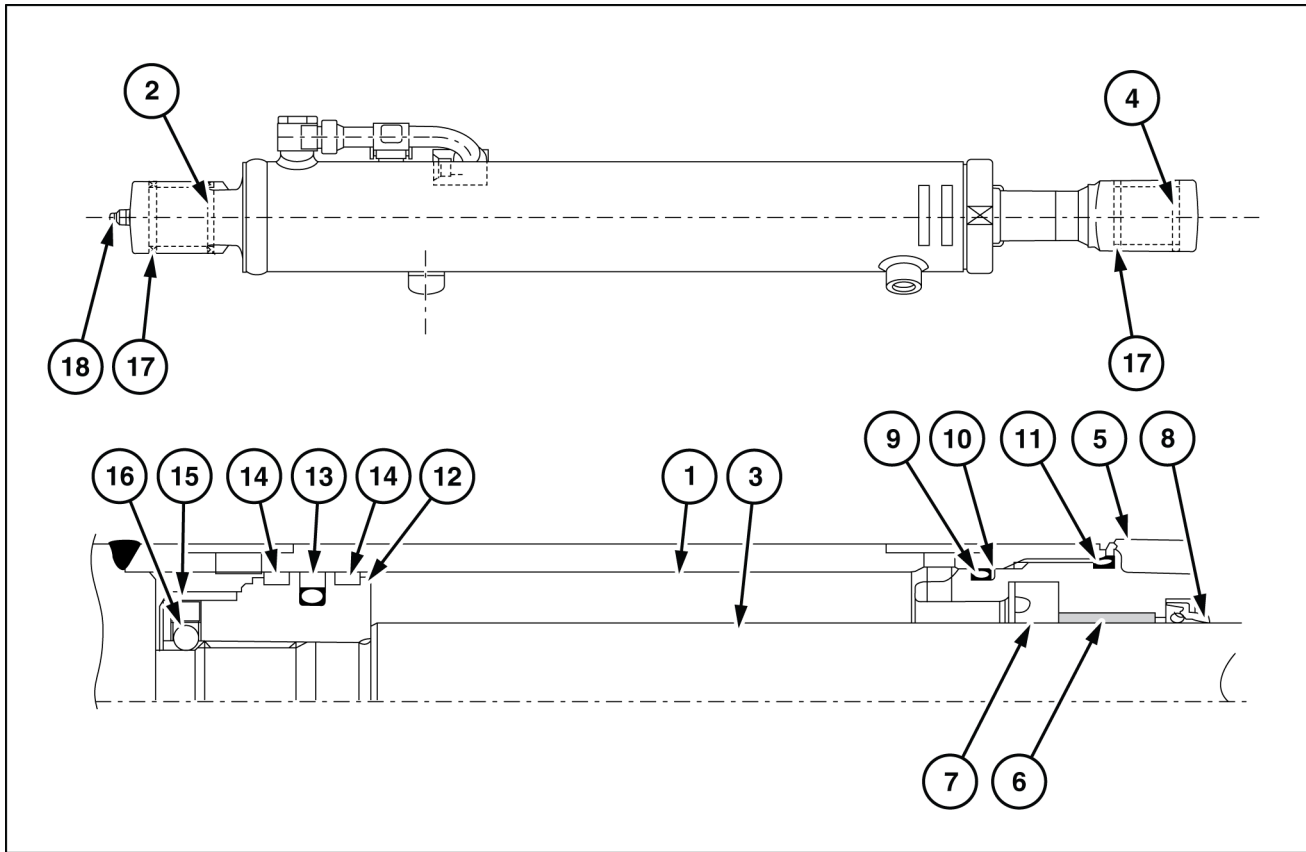

TULI12EXN2793FB 1

No.	Name	Qty.	No.	Name	Qty.
1.	Cylinder liner	1	10.	Back-up ring	1
2.	Bushing	1	11.	O-ring	1
3.	Rod	1	12.	Piston	1
4.	Bushing	1	13.	Piston gasket	1
5.	Cylinder head	1	14.	Piston guide ring	2
6.	Guide bushing	1	15.	Dowel	1
7.	Seal ring	1	16.	Ball	1
8.	Wiper ring	1	17.	Dust wiper ring	4
9.	O-ring	1	18.	Grease cup	2

Contents

Hydraulic systems - 35

Swing arm hydraulic system - 739

TECHNICAL DATA

Swing cylinder	
General specification	3
Torque	3

FUNCTIONAL DATA

Swing cylinder	
Component identification	4

SERVICE

Swing cylinder	
Prepare	5
Remove	6
Install	7

Blade lifting cylinder - Component identification

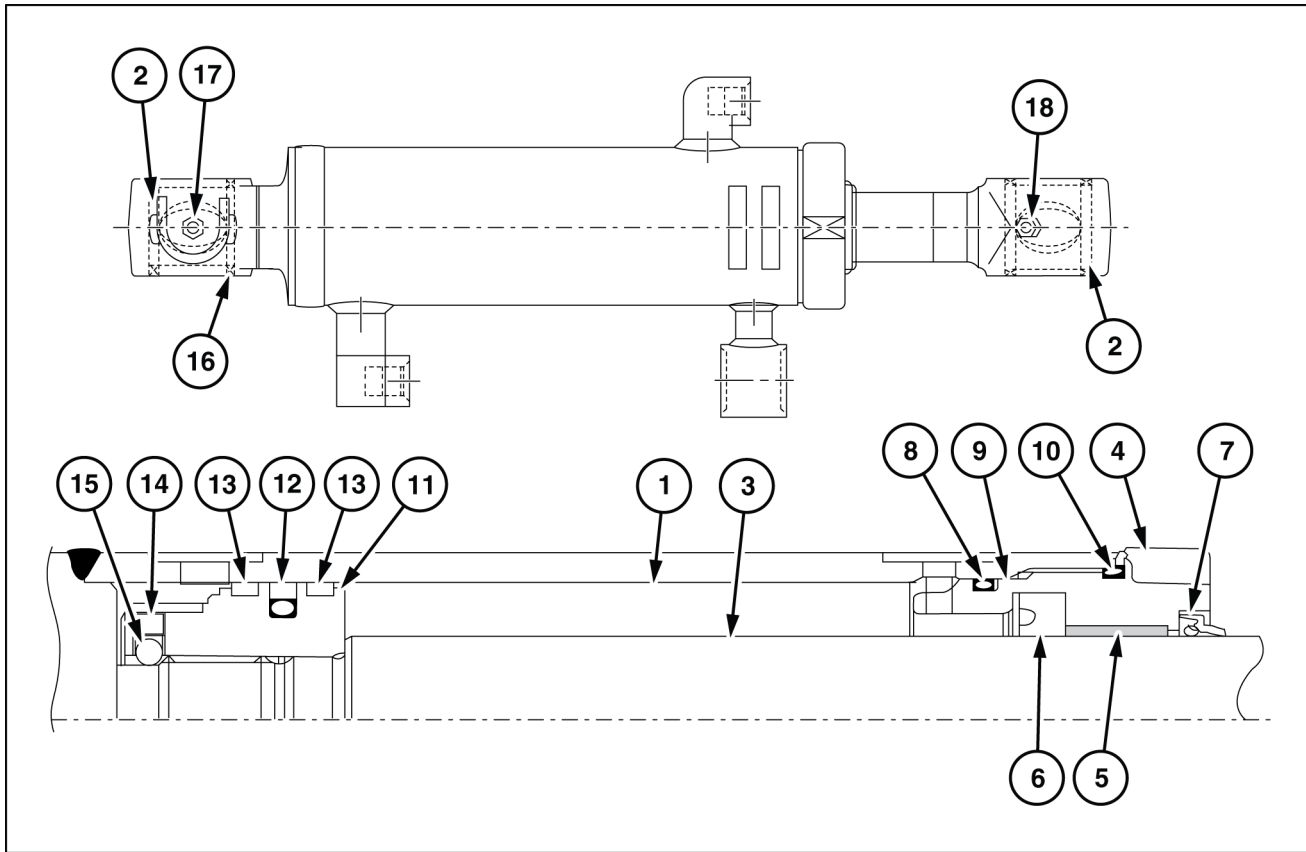

TULI12EXN2796FB 1

No.	Name	Qty.	No.	Name	Qty.
1.	Cylinder liner	1	10.	O-ring	1
2.	Bushing	1	11.	Piston	1
3.	Rod	1	12.	Piston gasket	1
4.	Cylinder head	1	13.	Piston guide ring	2
5.	Bushing	1	14.	Dowel	1
6.	Seal ring	1	15.	Ball	1
7.	Wiper ring	1	16.	Dust wiper ring	4
8.	O-ring	1	17.	Grease nipple	1
9.	Back-up ring	1	18.	Grease nipple	1

Index

Frames and ballasting - 39

Upper frame - 101

Upper frame - Install	5
Upper frame - Prepare	3
Upper frame - Remove	4

Contents

Frames and ballasting - 39

Ballasts and supports - 140

SERVICE

Counterweight

Remove	3
Install	4

Track frame - Remove - Track width enlargement device

The track width enlargement device is only applicable to **CX18B** model.

1. Lift the machine by approximately **30 cm (11.81 in)** to guarantee safety in the working area under the machine and place a stable support on the four sides of the machine, to the left and to the right, to the front and to the rear of the crawlers.
2. Release any possible pressure from the hydraulic oil tank.

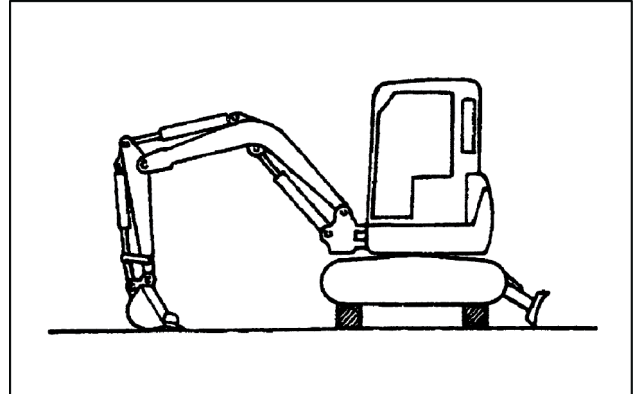

TULI12EXN2933AA 1

3. Loosen and remove the screws **(1)** with the relevant washers **(2)** and **(3)**. Disassemble the cover **(4)**.

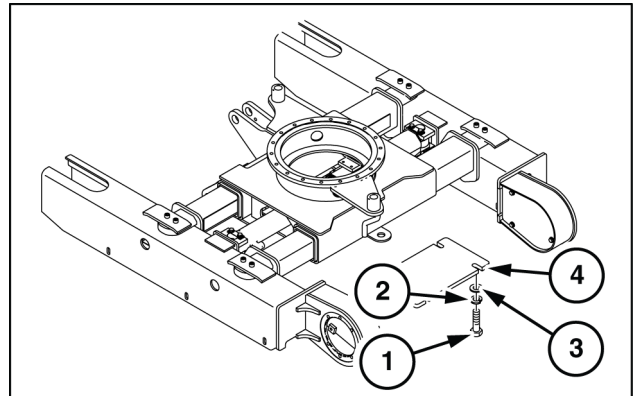

TULI12EXN2934AB 2

Contents

Tracks and track suspension - 48

Tracks - 100

TECHNICAL DATA

Tracks	
General specification	3

SERVICE

Rubber track	
Remove	4
Install	5
Check	6

Idler wheel - Disassemble

1. Remove the supports (4) by extracting them from the shaft (3).
2. Remove the plug (8) and drain oil: **60 cm³ (3.66 in³)**

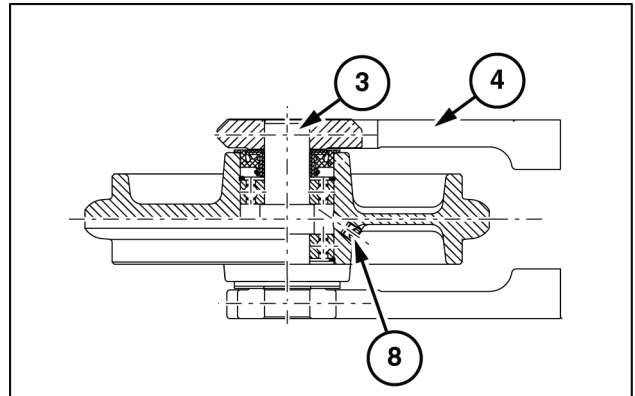

TULI12EXN2967AB 1

3. Remove the seal ring (7) and the elastic ring (6) from one side of the wheel.

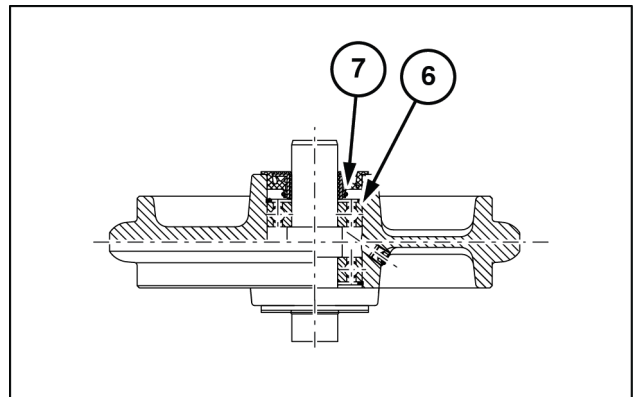

TULI12EXN2968AB 2

4. Turn the wheel (2) upside down and place it onto an appropriate support (S).
5. Using a tool and a press, remove the shaft (3) along with the bearing (5).
6. If bearing (5) replacement is not necessary, do not remove it from the shaft (3).

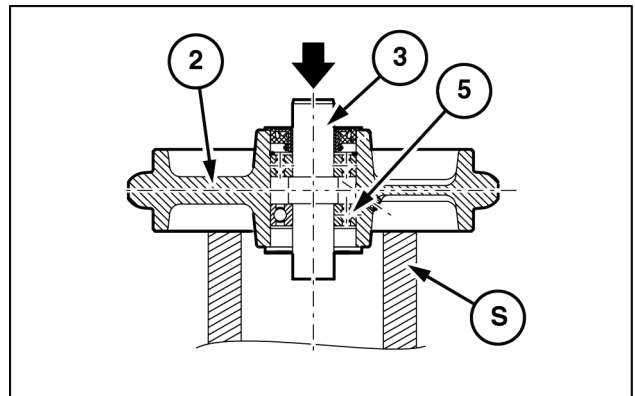

TULI12EXN2969AB 3

Index

Tracks and track suspension - 48

Track rollers - 138

Track frame roller - Assemble	7
Track frame roller - Component identification	3
Track frame roller - Disassemble	6
Track frame roller - Install	5
Track frame roller - Remove	4

Name: **E-6**
 Abbreviation: Gauge cluster (only on models with two speed travel motors)
 Nominal voltage: **12 V**

1.	Lighting (+)
2.	Glow plugs (-)
3.	Charge (-)
4.	Engine oil pressure (-)
5.	Power supply (+) (engine oil pressure water temperature)
6.	2 nd speed selection
7.	2 nd speed selection
8.	Power supply (glow plug charge)
9.	Air filter (-)
10.	
11.	
12.	
13.	Starting
14.	
15.	Fuel ignition from ground
16.	
17.	Grounding
18.	
19.	
20.	Fuel unit

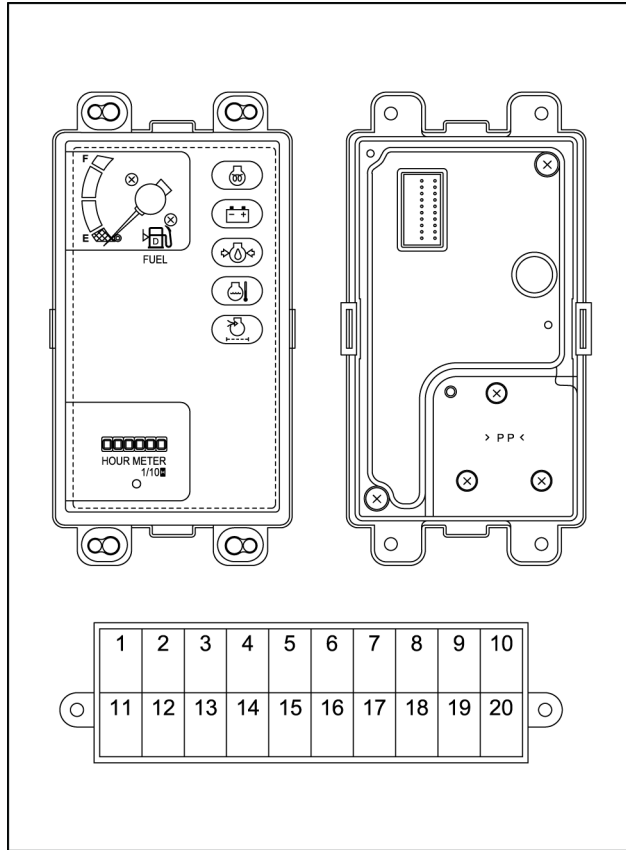

TUL12EXN3106BA 8

Name: **E-7**
 Abbreviation: Power socket
 Nominal voltage: **12 V**

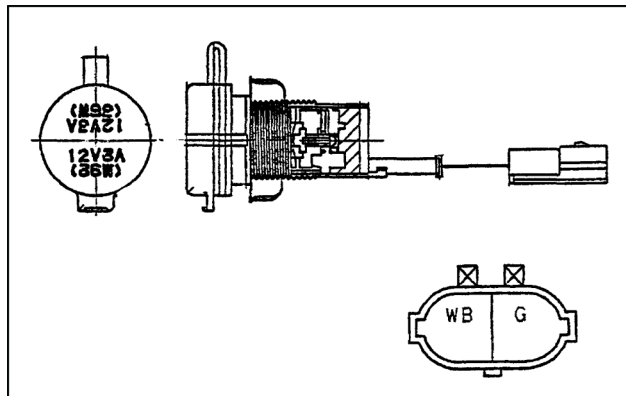

TUL12EXN3107AA 9

Name: **E-8**
 Abbreviation: Glow plug
 Nominal voltage: **11 VDC**
 Nominal current: **9.5 A**

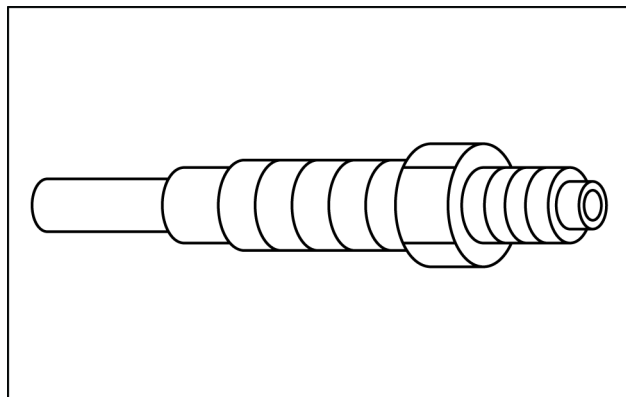

TUL12EXN3108AA 10

Contents

Electrical systems - 55

Harnesses and connectors - 100

FUNCTIONAL DATA

Harnesses and connectors

Overview 3

Wiring schema - Upper frame wiring harness 5

Fuse and relay box

Component localisation 14

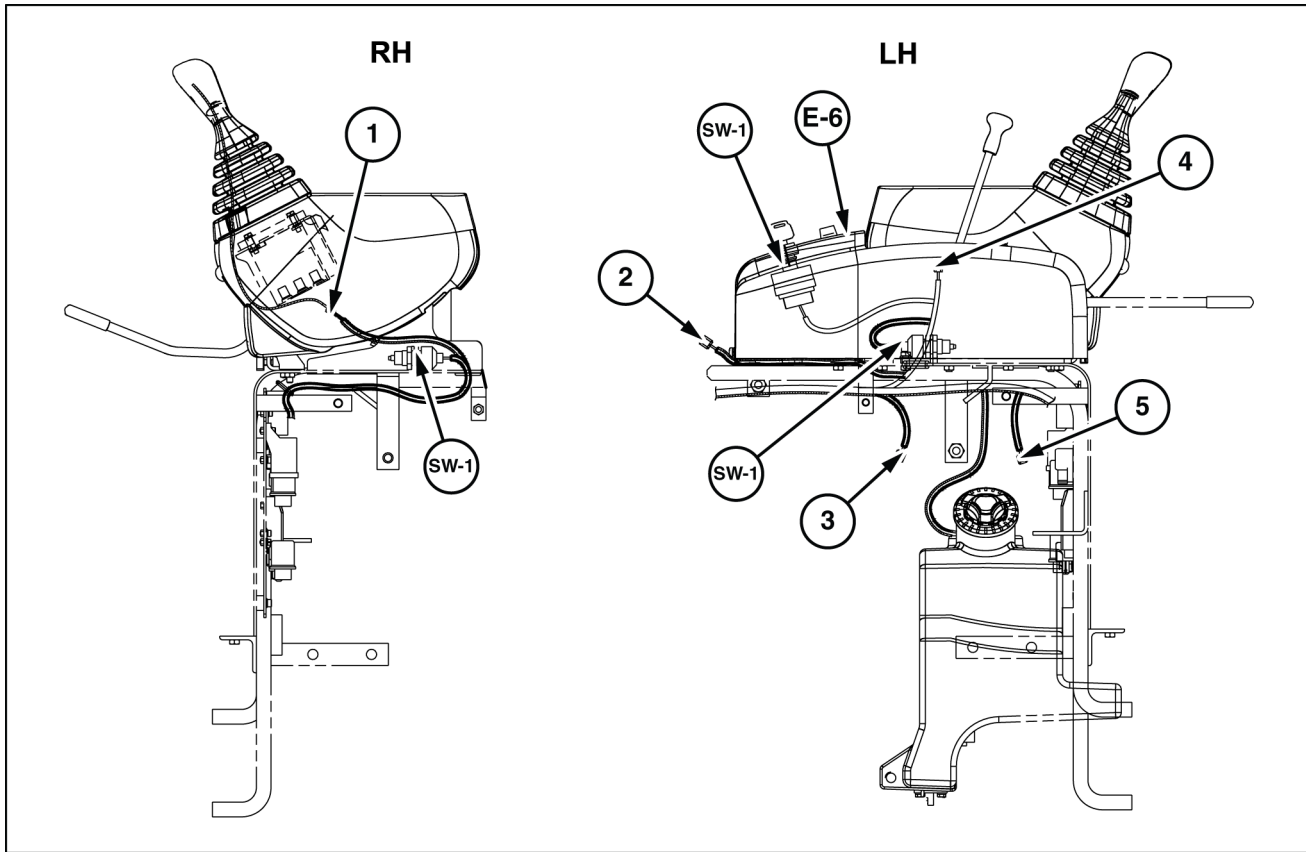

TULI12EXN2546FB 8

- | | |
|-----------------------------|-----------------------|
| 1. To horn | E-6. Instrument panel |
| 2. To cab wiring harness | SW-1. Starter switch |
| 3. To power reserve | |
| 4. To instrument panel | |
| 5. To heater wiring harness | |

Engine stop solenoid - Component identification

1. Nut
2. Stop solenoid

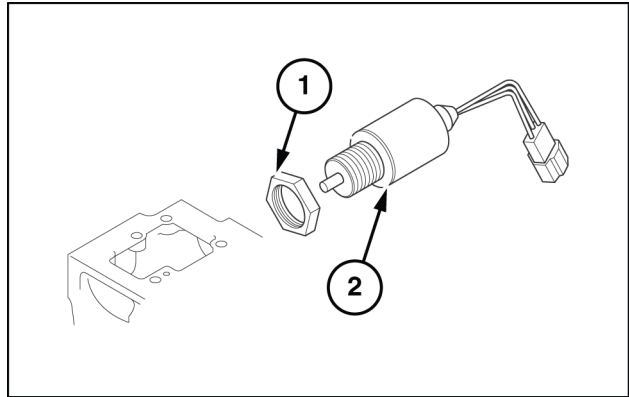

TUL112EXN3083AB 1

Coil check

Inspect the armature coil using a growler (**G**).
Place an iron bar against the armature core. If the iron bar (**I**) vibrates, replace the armature with a new one.

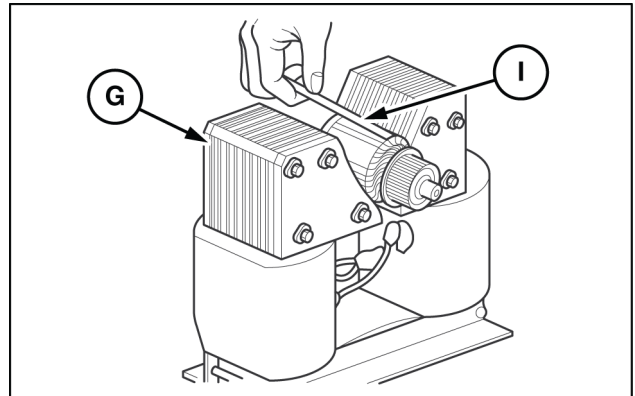

TULI12EXN3555AB 7

Check that there is no continuity between the commutator and the shaft (core).
If any continuity is observed, replace the armature with a new one.

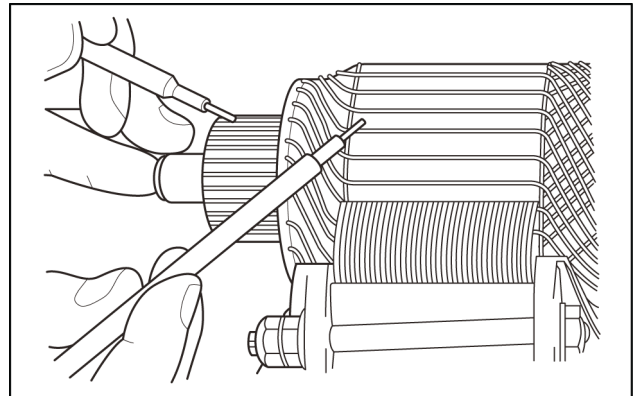

TULI12EXN3556AA 8

Check that there is continuity between segments in various combinations.
If poor or no continuity is observed, replace the armature with a new one.

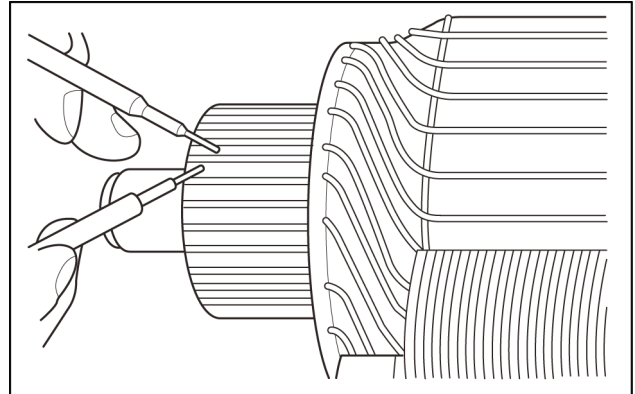

TULI12EXN3557AA 9

Inspection of piston covers

Replace the rear cover if a bearing is worn.

Contents

Electrical systems - 55

Cold start aid - 202

FUNCTIONAL DATA

Glow plug system	
Component identification	3

SERVICE

Glow plug system	
Inspect	4
Install	5

Adjusted voltage check (type of CI regulator)

1. Disconnect (+) battery (6) terminal and connect an ammeter (1) across the line.
2. Connect a voltmeter (5) between terminal L and ground.
3. The indication of the voltmeter must be 0 when the starter switch (4) is Off.
4. The indication of the voltmeter must be considerably lower than the battery (6) voltage when the starter switch is On (engine Off).
5. Start the engine with the ammeter (1) terminals disconnected.
6. Read the voltmeter (adjusted voltage) when the ammeter reading is 5 A or lower, at 2500 RPM and when the lamp (3) turns Off.

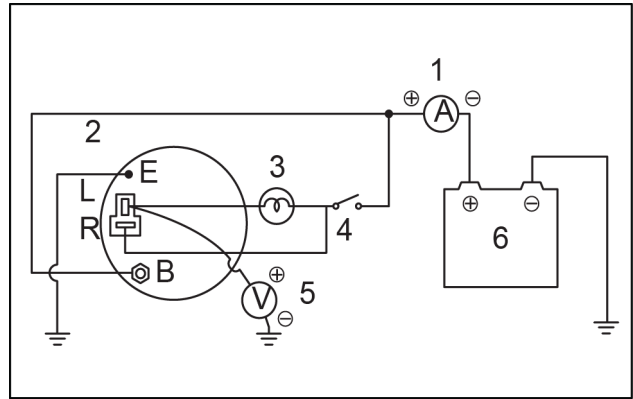

TULI12EXN3080AA 1

Item	Standard	V - A
Adjusted voltage 20 °C (68 °F)	A007TA0171B	14.4 - 15.0 V 12 V - 40 A

Output check

1. Disconnect the battery (6) ground cable.
2. Connect B terminal of the alternator (2) to the ammeter (1), then connect the voltmeter (5) between B terminal and ground.
3. Connect the battery (6) ground cable.
4. Start engine.
5. Immediately apply all loads such as lamps.
6. Increase the engine speed and measure the maximum output current at the specified alternator (2) rotation speed with the voltmeter (5) indicated the specified value.
7. If the measured value meets the standard, the output is normal.

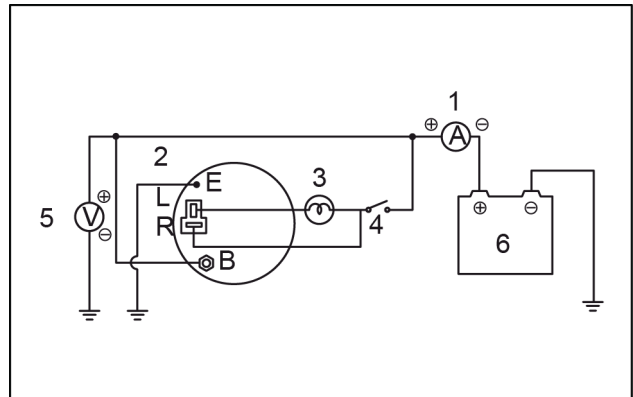

TULI12EXN3081AA 2

Item	Standard	Standard	
		Terminal voltage/current	Alternator rotation speed
Output characteristics (when hot)	A007TA0171B	13.5 V / 21 A	2500 RPM
		13.5 V / 37 A	5000 RPM

Install the front bracket **(8)**, the stator **(9)** and the rear bracket **(12)** and secure them with the screws **(1)**.

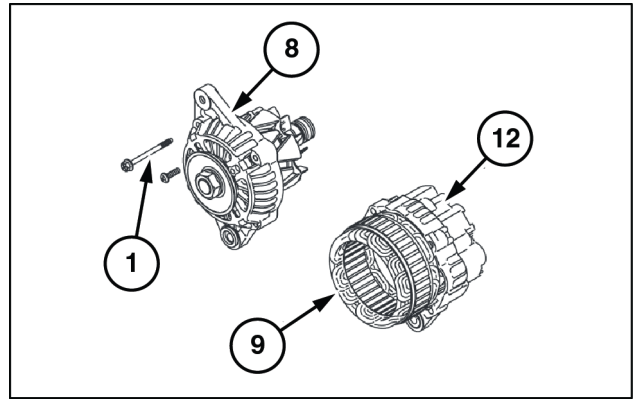

TULI12EXN3507AB 7

Contents

Booms, dippers, and buckets - 84

[84.114] Boom pivoting support	84.1
[84.910] Boom	84.2
[84.912] Dipper arm	84.3
[84.100] Bucket.....	84.4

Boom - Service limits

Tolerances between pins and bushing

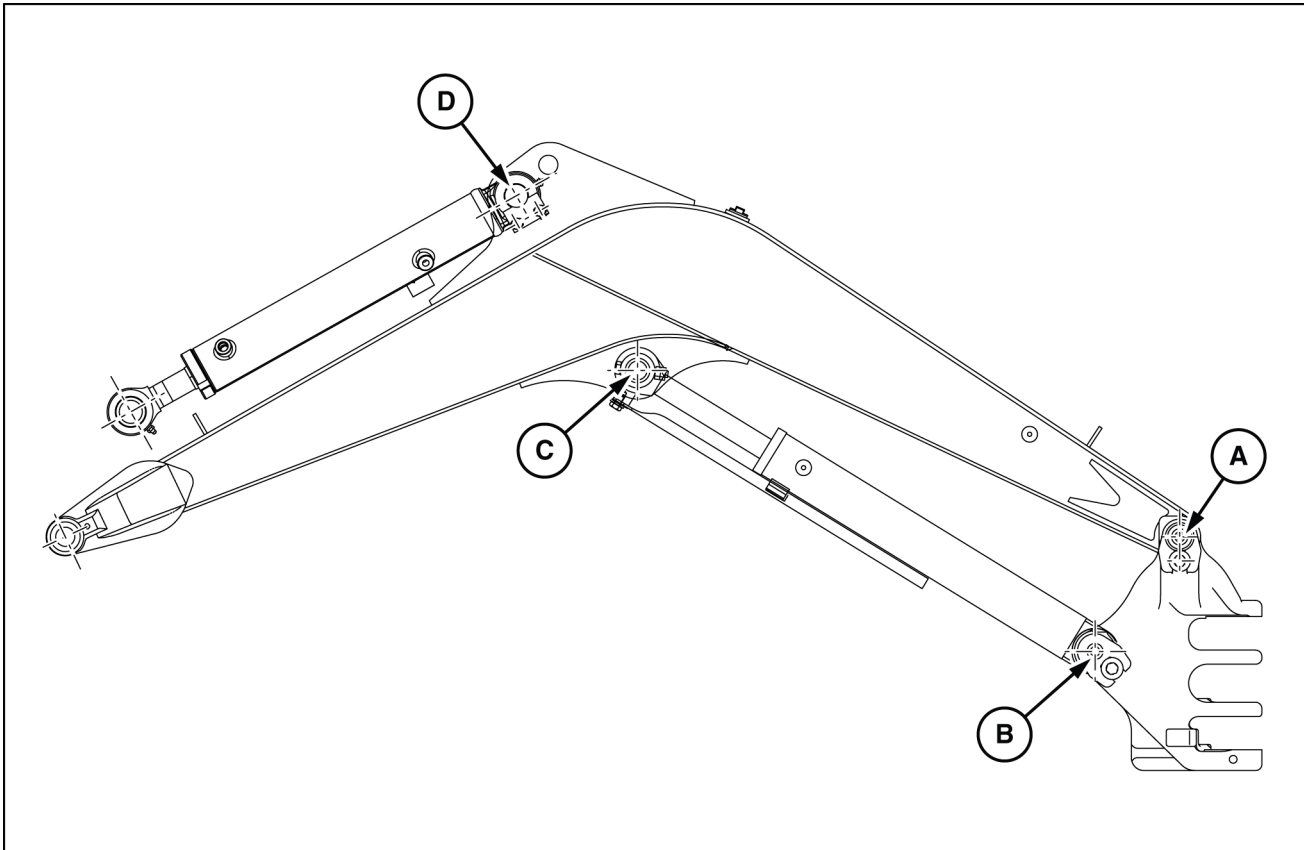

TULI12EXN2523FB 1

Location	Part	Standard dimensions			Play	Remedy
		Pin diameter	Tolerance on pin diameter	Tolerance on bushing bore diameter	Standard value	
A.	Boom	ø30 mm (1.18 in)	-0.02 - -0.05 mm (-0.001 - -0.002 in)	0.1 - 0.075 mm (0.004 - 0.003 in)	0.095 - 0.15 mm (0.004 - 0.006 in)	Replace bushing or pin
B.	Boom cylinder (bottom side)	ø30 mm (1.18 in)	-0.02 - -0.08 mm (-0.001 - -0.003 in)	0.18 - 0.05 mm (0.007 - 0.002 in)	0.07 - 0.26 mm (0.003 - 0.010 in)	
C.	Boom cylinder (rod side)	ø30 mm (1.18 in)	-0.03 - -0.08 mm (-0.001 - -0.003 in)	0.18 - 0.05 mm (0.007 - 0.002 in)	0.08 - 0.26 mm (0.003 - 0.010 in)	
D.	Arm cylinder (bottom side)	ø35 mm (1.38 in)	-0.03 - -0.08 mm (-0.001 - -0.003 in)	0.18 - 0.05 mm (0.007 - 0.002 in)	0.08 - 0.26 mm (0.003 - 0.010 in)	

Booms, dippers, and buckets - Dipper arm

No.	Name	Short	Long
A	Length	1020 mm (40.16 in)	1220 mm (48.03 in)
B	Distance between pins	R220 mm (8.66 in)	
C	Distance between pins	R753 mm (29.65 in)	
D	Distance between pins	R110 mm (4.33 in)	
E	Distance between pins	192 mm (7.56 in)	
F	Distance between pins	117.5 mm (4.63 in)	
G	Distance between pins	7 mm (0.28 in)	
H	Width of bucket fastening hub	100 mm (3.94 in)	
H1	Width of lever fastening hub	110 mm (4.33 in)	
J	Width of arm fastening hub	103 mm (4.06 in)	
K	Inner width of bucket cylinder mounting plates	41 mm (1.61 in)	
L	Inner width of arm cylinder mounting plate (rod side)	51 mm (2.01 in)	
M	Dimensions of bucket levers	195 mm (7.68 in)	
N	Dimensions of bucket connecting rod	195 mm (7.68 in)	
D1	Bushing outer diameter	ø40 mm (1.57 in)	
D2	Bushing outer diameter	ø40 mm (1.57 in)	
D3	Bushing outer diameter	ø40 mm (1.57 in)	
d1	Pin diameter	ø30 mm (1.18 in)	
d2	Pin diameter	ø30 mm (1.18 in)	
d3	Pin diameter	ø30 mm (1.18 in)	
d4	Pin diameter	ø30 mm (1.18 in)	
d5	Pin diameter	ø35 mm (1.38 in)	

Contents

Booms, dippers, and buckets - 84

Bucket - 100

TECHNICAL DATA

Bucket	
General specification	3
Dimension	3

SERVICE

Bucket	
Remove	4
Install	5

Contents

Dozer blade and arm - 86

Dozer blade - 110

TECHNICAL DATA

Dozer blade	
Dimension	3

FUNCTIONAL DATA

Dozer blade	
Overview	4
Exploded view	6

SERVICE

Dozer blade	
Remove	7
Install	8

Contents

Platform, cab, bodywork, and decals - 90

[90.150] Cab.....	90.1
[90.114] Operator protections	90.2
[90.120] Mechanically-adjusted operator seat.....	90.3
[90.105] Machine shields and guards	90.4
[90.116] Fenders and guards.....	90.5

Contents

Platform, cab, bodywork, and decals - 90

Operator protections - 114

SERVICE

Roll Over Protective Structure (ROPS) frame canopy	
Remove	3
Install	4
Disassemble	5
Assemble	6

Operator seat - Install

1. Use 4 screws **M8 x 20 (2)** and relevant washers **(3)** to install the operator seat **(1)**.

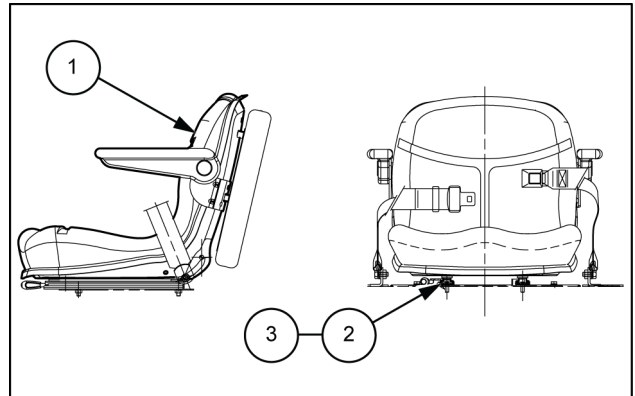

SMIL13MEX0372AB 1

CLICK HERE TO **DOWNLOAD** THE COMPLETE MANUAL

- Thank you very much for reading the preview of the manual.
- You can download the complete manual from: www.heydownloads.com by clicking the link below



- Please note: If there is no response to CLICKING the link, please download this PDF first and then click on it.

CLICK HERE TO **DOWNLOAD** THE COMPLETE MANUAL