

# 1816, 1816B, AND 1816C UNI-LOADERS

## TABLE OF CONTENTS

DIVISION/SECTION	SECTION NO.	FORM NO.
<b>1 GENERAL</b>		
Safety Rules, Service Manual Introduction, and Torque Specifications .....	1001	8-41040
Maintenance and Lubrication .....	1002	8-41040
Engine Specifications - 1816C .....	1003	8-41040
<b>2 ENGINES</b>		
Troubleshooting a Hard Starting Engine and D61880 Starter (Square Housing) - 1816 and 1816B .....	2001	8-41040
Engine Troubleshooting .....	2002	8-41040
Engine Removal and Installation - 1816 and 1816B and Drive Belts - 1816 .....	2003	8-41040
Engine Removal Installation, 1816C .....	2004	8-41040
Tecumseh Engines Mechanic's Handbook - 1816 and 1816B .....		691462A
Onan Engine - 1816C .....	2006	8-41040
Engine Accessories .....	2007	8-41040
<b>3 FUEL SYSTEM</b>		
Engine Controls, Fuel Lines, Fuel Filter, Electric Fuel Pump .....	3001	8-41040
Carburetor - 1816C .....	3002	8-41040
<b>4 ELECTRICAL</b>		
Electrical System Troubleshooting .....	4002	8-41040
Wiring Diagrams .....	4003	8-41040
Gauges .....	4004	8-41040
Battery .....	4005	8-41040
Starter .....	4006	8-41040
<b>NOTE:</b> Also see the following sections:		
Starter - 1816 and 1816B .....	Sections 2001 and 2005	
Alternator - 1816, 1816B .....	Sections 2001 and 2005	
Alternator - 1816C .....	Sections 2006 and 4002	
Spark Ignition System - 1816, 1816B .....	Sections 2001 and 2005	
Spark Ignition System - 1816C .....	Sections 2006 and 4002	
<b>6 POWER TRAIN</b>		
Hydrostatic Troubleshooting, Testing, and Adjustment for Machines with Vickers Piston Pumps .....	6001	8-41040
Hydrostatic Troubleshooting, Testing, and Adjustment for Machines with Sundstrand Piston Pumps .....	6002	8-41040
Hydrostatic System Diagrams and Operation for Machines with Vickers Piston Pumps .....	6003	8-41040
Hydrostatic System Diagrams and Operation for Machines with Sundstrand Piston Pumps .....	6004	8-41040
Vickers Piston Pump .....	6005	8-41040
Sundstrand Piston Pump .....	6006	8-41040
Hydrostatic Motor .....	6007	8-41040

Reprinted

CLICK HERE TO **DOWNLOAD** THE COMPLETE MANUAL

- Thank you very much for reading the preview of the manual.
- You can download the complete manual from: [www.heydownloads.com](http://www.heydownloads.com) by clicking the link below



- Please note: If there is no response to CLICKING the link, please download this PDF first and then click on it.

CLICK HERE TO **DOWNLOAD** THE COMPLETE MANUAL

# Section 1002

## MAINTENANCE AND LUBRICATION

Written In *Clear  
And  
Simple  
English*

## Crankshaft

Type .....	balanced
Material .....	ductile iron, induction hardened main bearing journals
Main Bearing Journal (Standard Size) .....	1.999 - 2.000 inches (50.78 - 50.80 mm)
Connecting Rod Journal (Standard Size) .....	1.625 - 1.626 inch (41.28 - 41.30 mm)
Crankshaft to Main Bearing Clearance .....	.002 - .004 inch (0.05 - 0.10 mm)
Crankshaft End Play .....	.006 - .012 inch (0.15 - 0.30 mm)
Crankshaft Gear to Camshaft Gear Backlash .....	.002 - .003 inch (0.05 - 0.08 mm)

## Main Bearing

Type .....	replaceable precision with thrust washer
Material .....	steel back aluminum
Length .....	one inch (25.4 mm)
Diameter (Standard Size) .....	2.001 - 2.004 inches (50.83 - 50.90 mm)

## Camshaft

Material .....	cast iron alloy
Camshaft Lift .....	.300 inch (7.62 mm)
Camshaft End Play (Minimum) .....	.003 inch (0.08 mm)
Camshaft Journal Diameter .....	1.374 inch (34.90 mm)
Camshaft to Camshaft Bearing Clearance .....	.001 - .003 inch (0.04 - 0.08 mm)
Length of Center Pin Extension From Camshaft Gear .....	.25/32 inch (19.8 mm)
Governor Cup Travel on Center Pin .....	.7/32 inch (5.6 mm)

## Camshaft Bearing

Number .....	two
Type .....	replaceable precision
Material .....	lead babbitt
Diameter .....	1.376 - 1.377 inch (34.95 - 34.98 mm)

POSSIBLE CAUSE	CORRECTION
Loss of compression.	Check compression. Correct compression is approximately 100 psi (689 kPa). Both cylinders must be approximately the same.
Not enough oil.	Fill crankcase to the correct level.
Restriction in air cleaner.	Service air cleaner.
Leakage by valves.	Grind valves.
Valve timing is not correct.	Check timing marks on camshaft gear and crankshaft gear.
Carburetor dirty or damaged.	Clean and repair carburetor. See Section 3002.
Ignition system malfunction.	Check and repair ignition system. See Section 4002.

### ENGINE IS RUNNING TOO HOT

POSSIBLE CAUSE	CORRECTION
Ignition timing is not correct.	Check contact points and ignition timing.
Carburetor adjustment is not correct (lean mixture).	Adjust carburetor. See Section 3002.
Obstruction in air flow around engine.	Remove any obstructions from air passages in engine shrouds and screen.
Too much load on engine.	Check operation of driven equipment. Decrease load.
Carbon in combustion chamber.	Remove cylinder head and clean carbon from cylinder head and piston.
Not enough oil.	Fill crankcase to correct level.

### ENGINE DOES NOT RUN EVENLY (ERRATIC SPEED)

POSSIBLE CAUSE	CORRECTION
Obstruction in vent in fuel filler cap.	Clean vent in fuel filler cap.
Governor parts not operating freely.	Clean or repair governor parts.

# Section 2004

## ENGINE REMOVAL AND ENGINE INSTALLATION - 1816C

Written In *Clear  
And  
Simple  
English*

# Tecumseh Engines Mechanic's Handbook

8 - 18 h.p.  
(CAST IRON ENGINES)

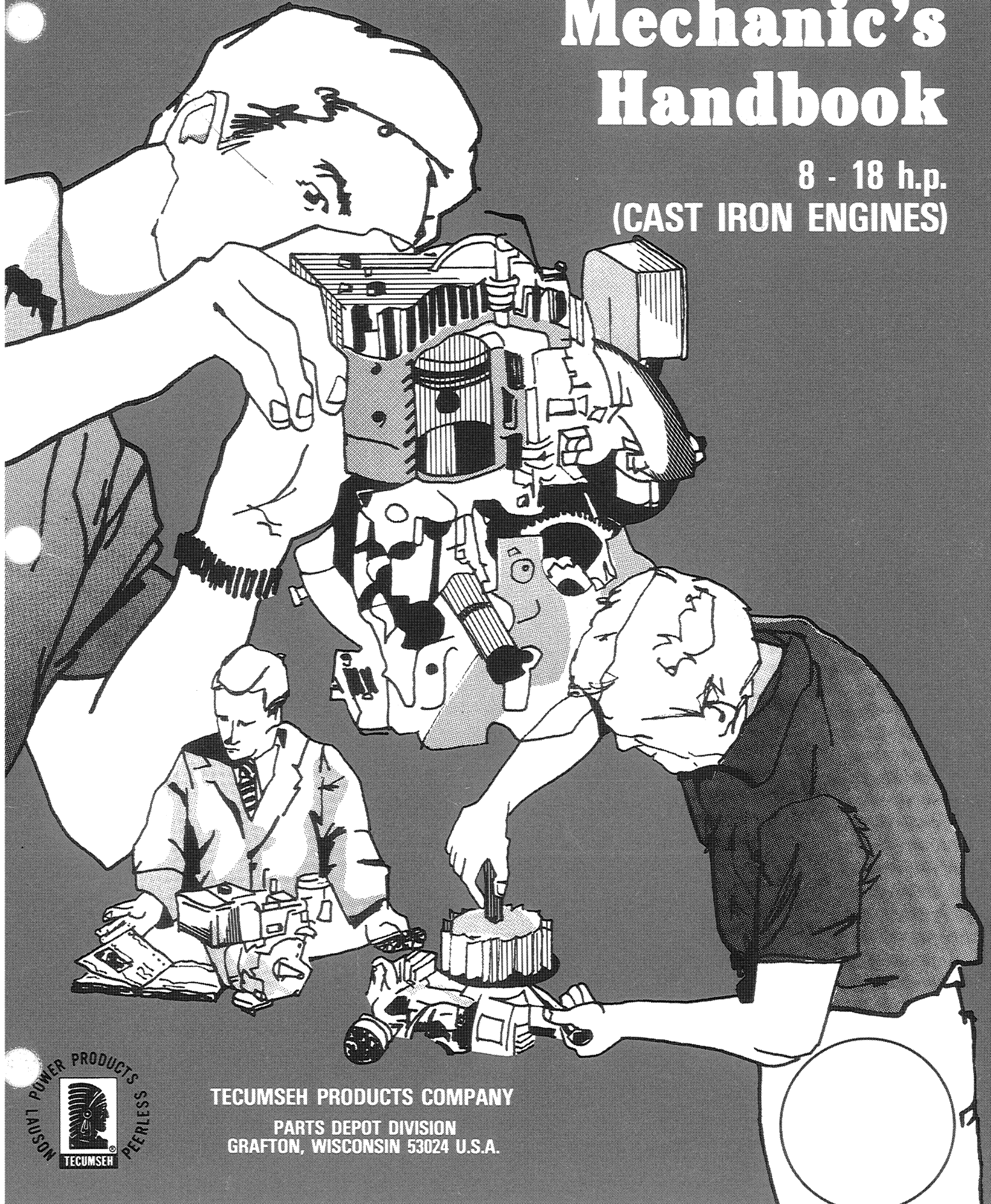

TECUMSEH PRODUCTS COMPANY

PARTS DEPOT DIVISION  
GRAFTON, WISCONSIN 53024 U.S.A.

Insert the seat with the grooved side into the cup. Press the viton seat squarely into the base.

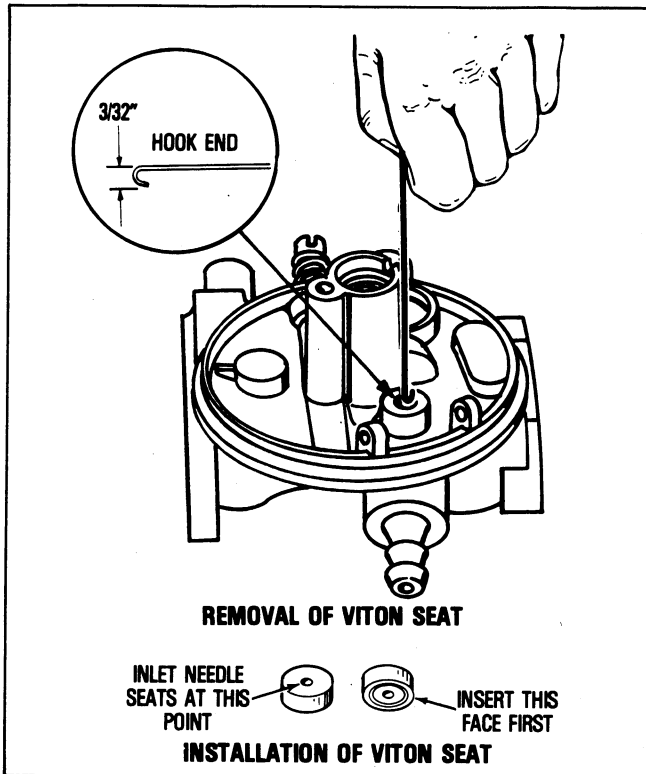

**FUEL INLET FITTING.** If necessary this fitting can be removed by pulling and twisting. Be sure to install in the same position as the original. When installing fitting, insert tip into the carburetor body, then coat the exposed portion of the shank with Loctite grade A; then press it in, until the shoulder contacts the carburetor body.

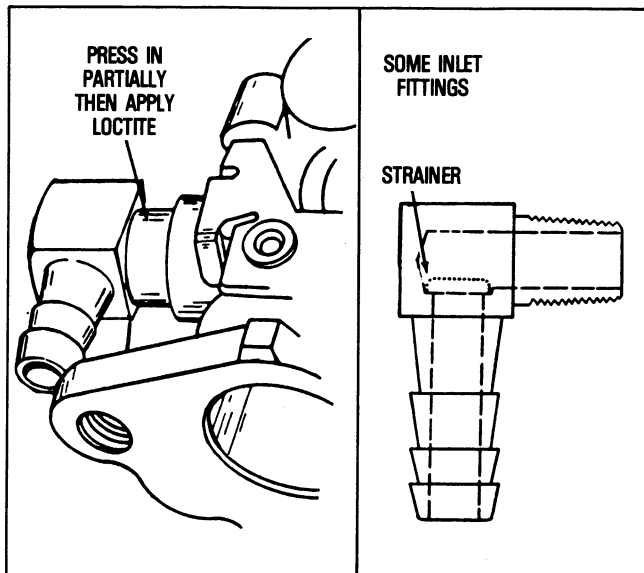

**CARBURETOR BODY.** When removing choke and throttle shafts, check shafts and bearings in carburetor body for wear. Any looseness in these areas can cause dirt to enter the engine and cause premature wear. If dust seals are present, these should be positioned next to the carburetor body.

Welch plugs should be removed for proper cleaning of carburetor. When all accessories and shafts have been removed, soak the carburetor in carburetor cleaner for a maximum of 30 minutes. Blow out all passages with compressed air in the opposite direction of normal fuel flow or use a soft tag wire.

Clean all metallic parts with solvent.

To do a proper cleaning job welch plugs should be removed to expose drilled passages. To remove welch plug, sharpen a small chisel to a sharp wedge point. Drive the chisel into the welch plug, push down on chisel and pry plug out of position.

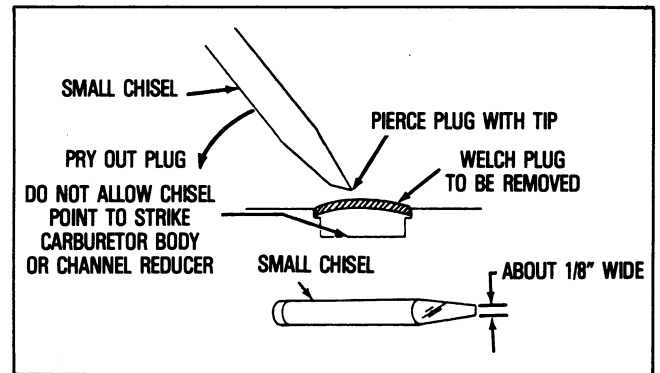

To install a new welch plug after cleaning, place welch plug into receptacle with raised portion up. With a punch equal, or greater than the size of the plug, merely flatten the plug. Do not dent or drive the center of the plug below the top surface of the carburetor.

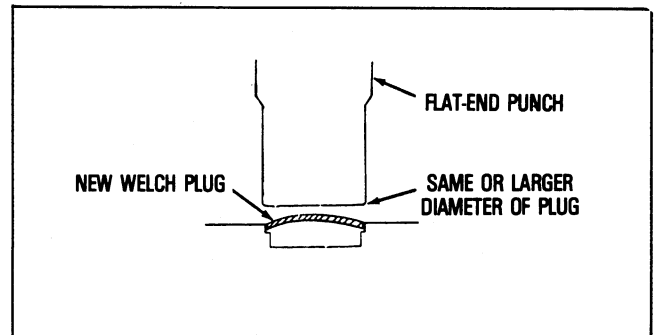

**SETTING THE FLOAT** With the float setting tool part No. 670253 check position of float as shown for all Tecumseh carburetors. The tab edge of the measurement tool must rest without force or a gap on the float. If the float is too high or too low adjust the height by removing the float and bend the tab accordingly.

If the required adjustment is minor the tab adjustment may be made without removing float and carefully inserting a small bladed screwdriver to bend the tab. Be careful not to affect other parts.

**NOTE:** On carburetors equipped with a fiber washer between the bowl and casting, use the fiber washer with the float setting tool as pictured.

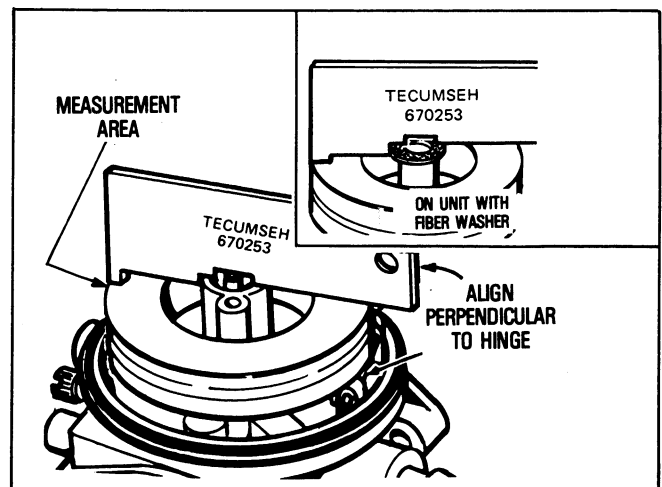

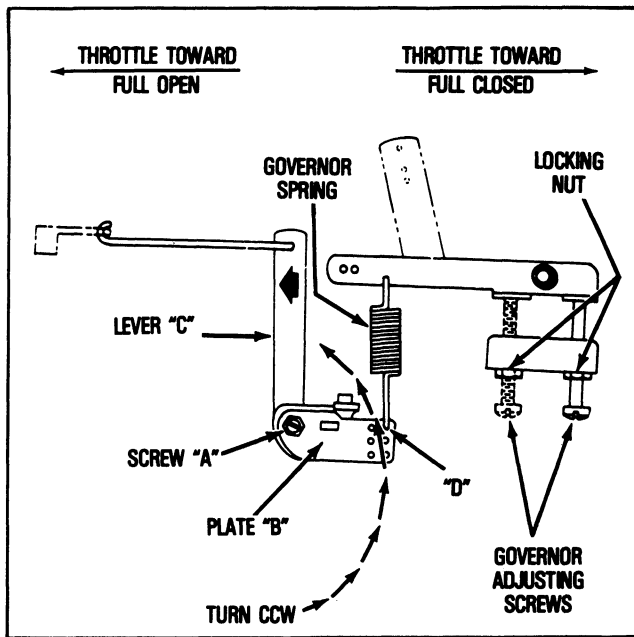

**VARIABLE SPEED ADJUSTMENT.** Before attaching the remote speed control (bowden wire) set the engine for maximum R.P.M. Use a good tachometer.

Move lever "A" clockwise until lower end strikes the adjusting screw "1".

Loosen lock nut on adjusting screw "1" and turn in (clockwise) to decrease R.P.M. and out counterclockwise to increase R.P.M.

**ADJUSTING FIXED SPEED.** The fixed speed adjusting screw is the optional position "2". Adjust it merely by starting the engine and after loosening the lock nut turn screw in (clockwise) to increase spring tension and hold engine at higher R.P.M. and out (counterclockwise) to decrease tension on spring and allow speed to be decreased more easily.

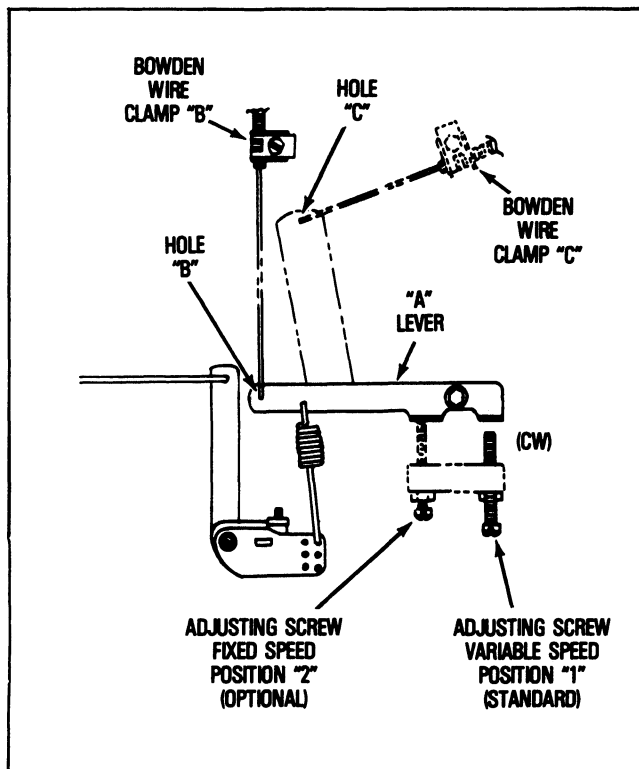

The wiring diagram shows a manually actuated starting switch. It also shows how the optional battery ignition system is connected into the electrical circuit. For units with magneto ignition, just eliminate the second load lead wire as shown by the dotted lines.

**WIRING DIAGRAM FOR KEY SWITCH AND SOLENOID.** The key switch in the figure supplies the current to activate the solenoid when turned to start position. It also allows the current to flow to the battery ignition coil if present.

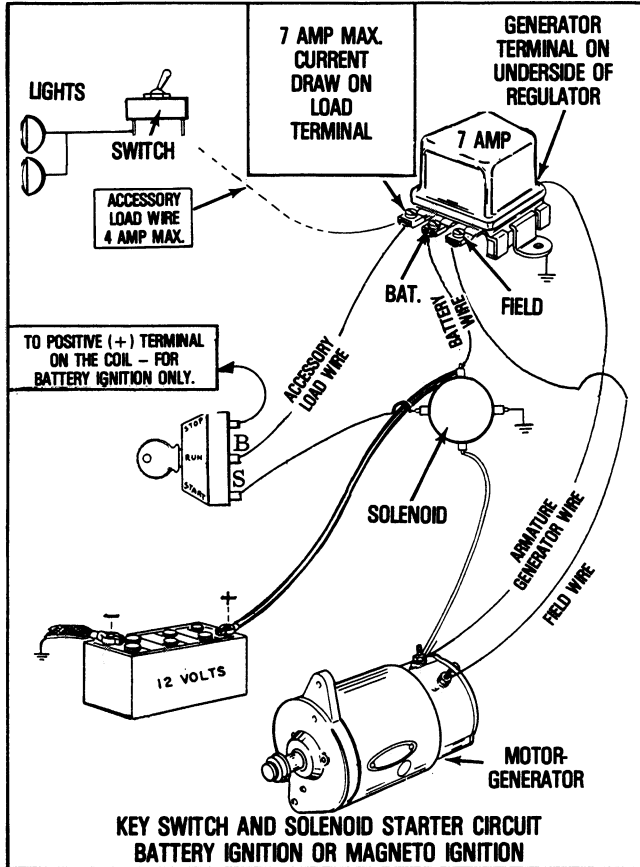

**MANUAL STARTER SWITCH.** Wiring diagram for larger capacity regulator. This regulator is a larger size and has only three connecting terminals. There are no terminals on the back side of the unit. It is more rectangular in shape than the square lower capacity unit.

A maximum current draw of 14 Amps can be connected to the battery terminal of this regulator. The battery ignition coil draws about 3 Amps. Only 11 Amps can be used for accessories on battery ignition models.

The starter switch can be either a heavy duty key switch or a push button type. The key switch may have a third terminal which would control current flow to the magneto or battery ignition coils.

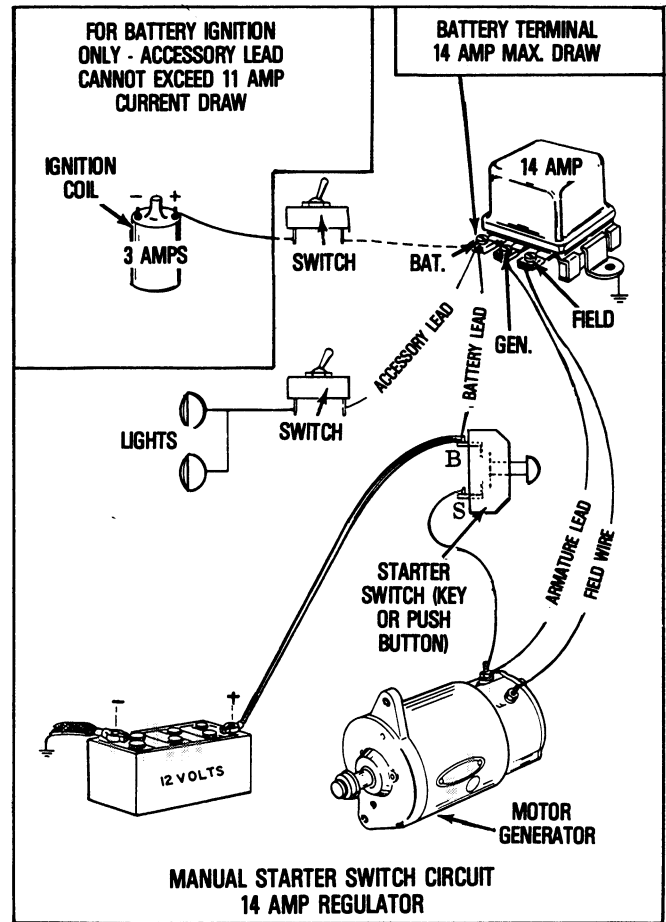

**SOLENOID AND KEY SWITCH DIAGRAM – THE SOLENOID.** There are two types of electric switches or solenoids.

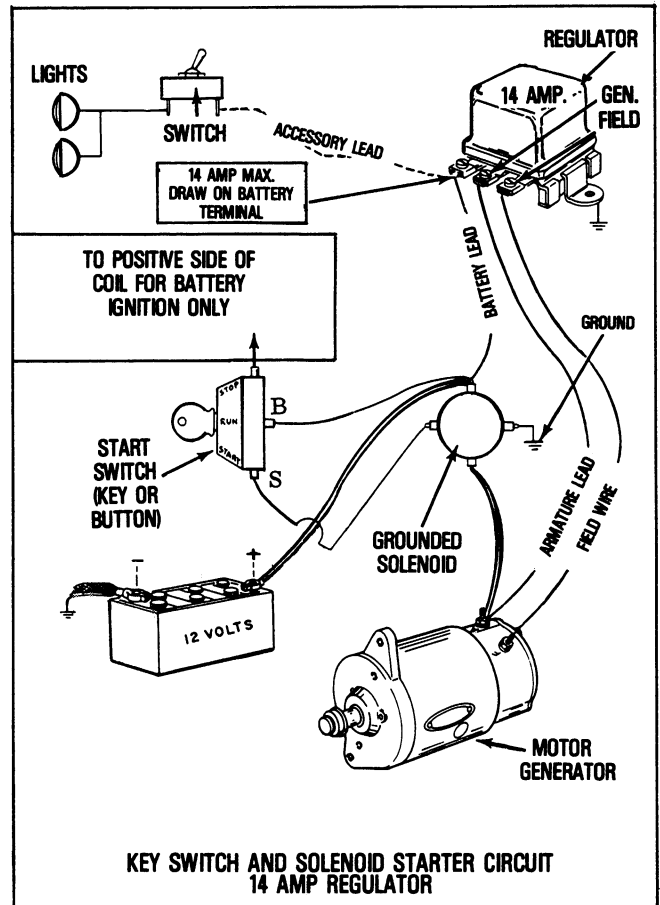

## SECTION 2. CONNECTING RODS

When reinstalling a used connecting rod ALWAYS use new nuts on the bolts. These are locking nuts and it is inexpensive insurance that the torque will be retained when the connecting rod is replaced.

This connecting rod must be installed with the match mark facing out of the cylinder, toward the P.T.O. end of the crankshaft. This will assure the correct positioning of the oil dipper. Install as illustrated.

The heads of the through bolts must be seated tight against the machined shoulder on the connecting rod. Failure to check this may result in a false torque reading and premature failure.

**IMPORTANT** - Torque to correct specifications. 110 inch pounds.

**NOTE** - Before installing, clean the connecting rod bearing surfaces with a clean cloth. Rods are coated with lead which will slightly oxidize in storage and this oxidation must be removed.

FOR ENGINE MODELS HH80, HH100 and HH120 and VALVE-IN-HEAD ENGINES.

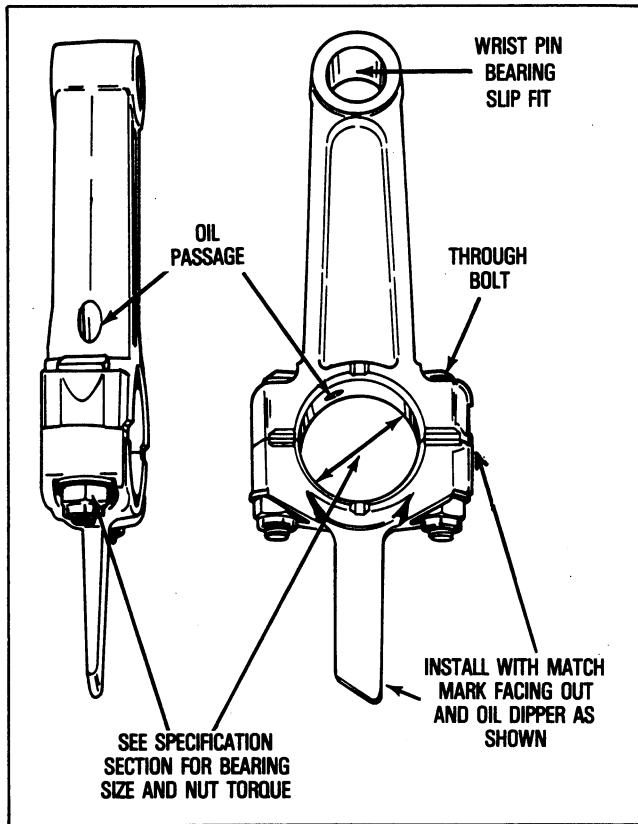

The vertical crankshaft 8 and 10 H.P. engines have a connecting rod with two lube holes. This rod is not interchangeable with the horizontal connecting rod. The above requirements listed for a horizontal crankshaft rod also apply to the vertical crankshaft engines connecting rod.

FOR ENGINE MODELS VH80 and VH100

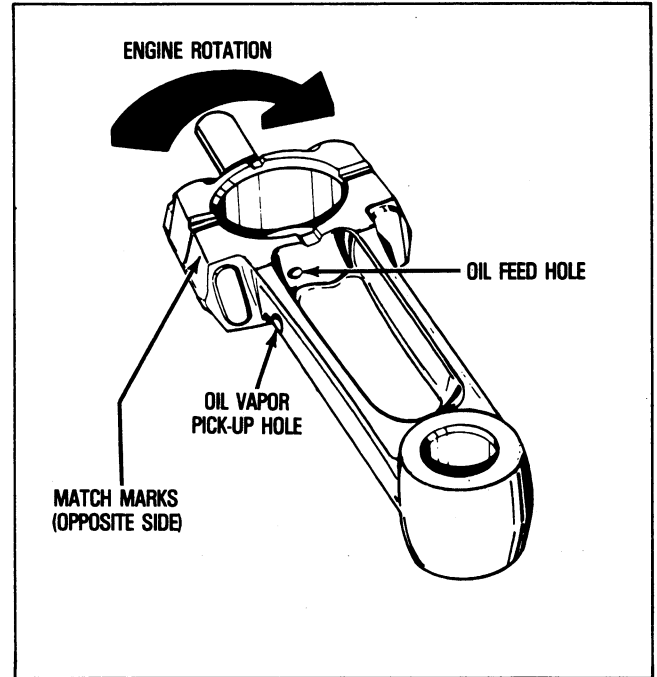

Torque to correct specifications – 110-inch pounds. After initial torque use a drift and a hammer (13 oz.) and strike the rod bearing cap above each lock nut. This will seat the cap releasing some torque on the lock nuts. Retorque lock nuts to specifications.

# CHAPTER 8. IGNITION SYSTEMS, CHARGING SYSTEMS BATTERY SERVICE and ELECTRICAL CONTROL PANELS

## SECTION 1. IGNITION SYSTEMS

### SOLID STATE SYSTEM IGNITION SERVICE.

a. General. The following checks and explanations are all that this system has. If nothing else is apparent, the ignition unit must be replaced. The parts of the system are:

1. Ignition coil.
2. Flywheel.
3. Ignition unit.
4. High tension lead.
5. Spark plug.

b. Spark Plug Check. Test ignition by using a test plug or hold the high tension lead terminal 1/8-in. from the spark plug. Crank the engine over rapidly. If a good blue spark jumps the gap, the ignition system is functional.

If no spark is present, make the following checks: c through f.

- c. Check high tension lead for a ground out or disconnect in the ignition unit.
- d. Check coil lead and connection to ignition unit terminal.

**CAUTION:** If the engine won't run, after previous acceptable performance, check the equipment ignition switch.

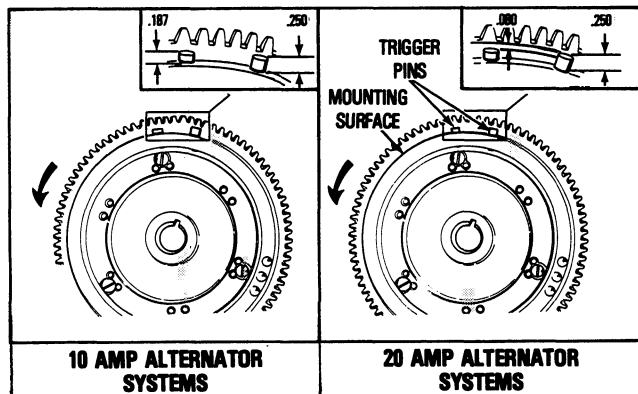
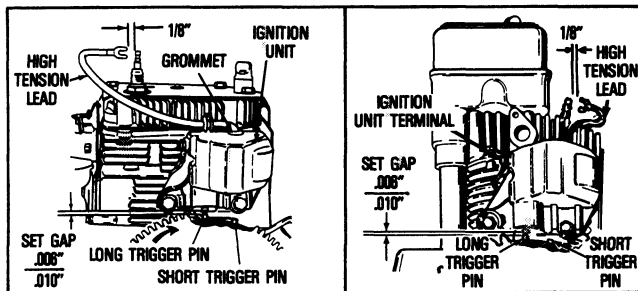

e. Air Gap Checks. Adjust the system so that a .006/.010" clearance exists between the ignition unit and the long trigger pin in the flywheel.

To adjust, loosen the retaining screw and move the unit to find proper gap.

f. Trigger Pins ...The long trigger pin on both the 10 and 20 amp system flywheels should extend .250" from the mounting surface.

The short pin on the 10 amp system should extend .187" from the mounting surface.

The short pin on the 20 amp system should measure .080" less than the longer pin.

If pins are to be replaced:

### TO INSTALL FLYWHEEL TRIGGER PINS, PART NO. 730201

#### Removal of Damaged Pins.

**CAUTION:** Pins must not be reused. Use care not to damage flywheel. Never hammer on a flywheel as permanent damage to the magnets could result.

Use vise-grip pliers to remove pins. If pins are very tight, hammer lightly on the pliers at the same time pulling on the pins. Do not twist. If a vise is used to secure the flywheel, use care not to damage.

#### INSTALLATION OF NEW TRIGGER PINS.

1. Position the flywheel with the fins on a flat surface. Holes toward you - See Figure.
  2. Coat shaft of pins with Locktite.
- CAUTION:** Do not use a hammer to drive in pins.

3. Use masking tape to cover wide-mouth pliers (channel lock type) and press fit the short pin into hole on right. Fit the long pin on the left.
4. Pins must be pressed up to pin shoulder. Wipe away any excess Locktite.

g. Coil Lead on 10 Amp Alternator Systems. Remove the coil lead from the ignition unit terminal - Attach leads from a standard ohmmeter to the lead eyelet terminal and to ground to check series resistance of the ignition generator coil.

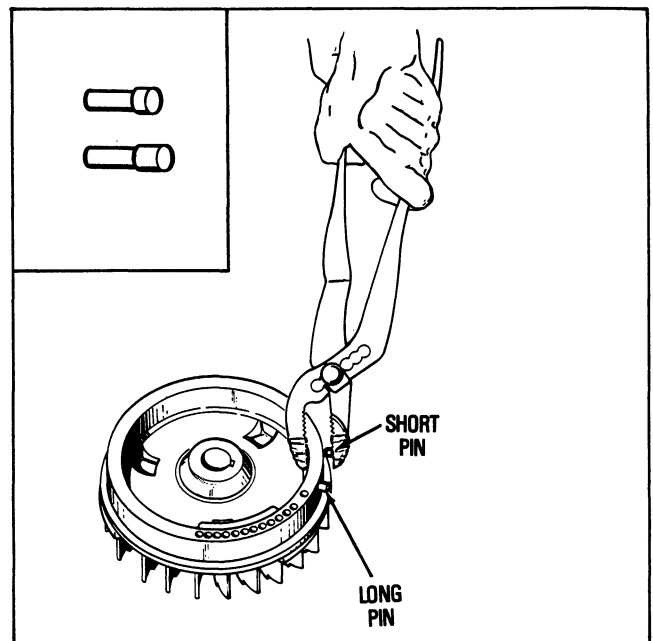

## SECTION 4. ELECTRICAL CONTROL PANELS

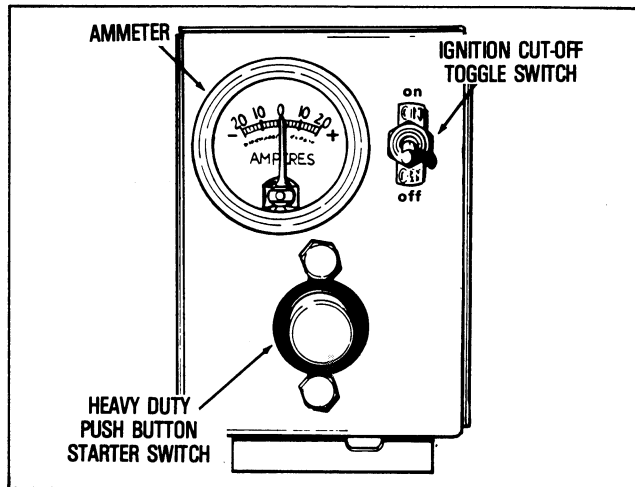

**ELECTRICAL CONTROL PANEL SERVICE PART NO. 730155.** The test procedures explained below will deal only with the control panel.

Before attempting to locate an apparent defect in the control panel switches or ammeter, insure all connections between control panel, starter and battery are secure and free from corrosion and wire or insulation breaks. Battery should be fully charged or be at a minimum of 75% charge. Engine ignition spark should be checked for an intense spark.

Remove side plates from control panel. Remove engine alternator connector plug from panel connector. Use a volt-ohm-millimeter or battery powered test light for the following tests. **CAUTION** - Remove (+) lead from battery before attempting any of the following tests.

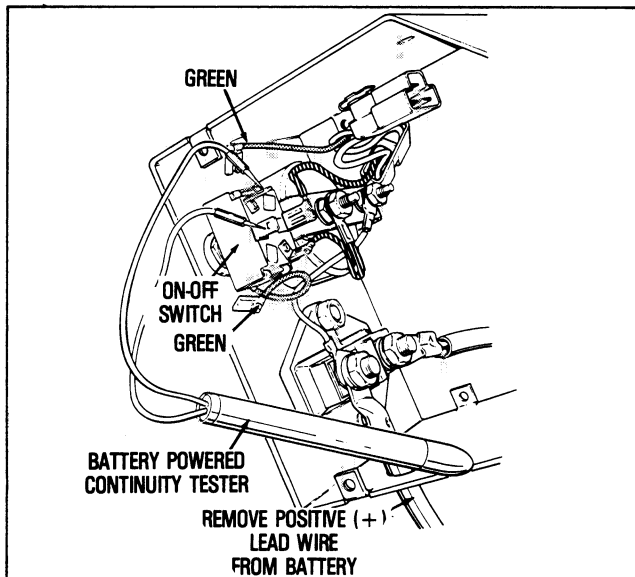

**ON-OFF SWITCH - IGNITION GROUND CIRCUIT.** Remove both the green wires from switch terminals. Attach test leads of tester (Battery type test light or ohmmeter) to switch terminals. Move toggle switch to the "ON" position. No continuity (light should not light) should exist. Leave test leads attached to switch and move switch to "OFF" position. Continuity should exist (light should light). If switch fails to either test, switch must be replaced.

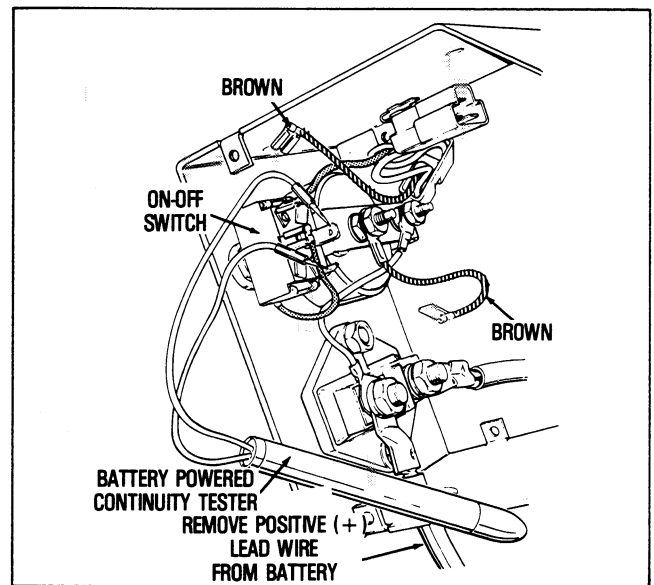

**ON-OFF SWITCH - DC RELAY CIRCUIT.** Remove both brown wires from switch terminal. Attach test leads to switch terminal. Place switch to the "ON" position. Continuity (test light should light) should exist. Leave test leads attached and move switch to the "OFF" position. Continuity should not exist (test light should not light). If switch fails either of these tests, switch must be replaced.

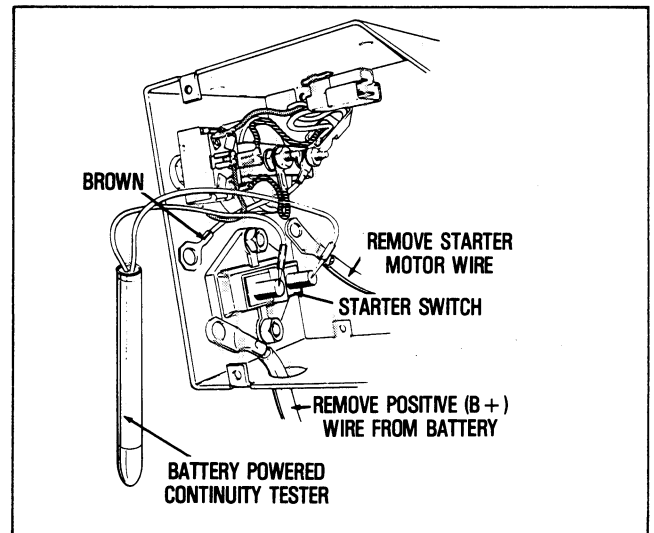

**STARTER SWITCH.** Remove wires from starter switch. Place test leads on to switch terminals. No continuity should exist (Test light should not light). Leave test leads attached depress starter button. Continuity should exist (Test light should light). If starter switch fails either of these tests, replace switch.

**AMMETER. CAUTION** - The ammeter will not show a charge if the battery is at full charge. The rate of charge will depend on the amount of charge in the battery. The lower the charge in the battery, the higher the reading on the ammeter. If ammeter does not show a charge or discharge, start and stop engine (use electric starter) several times to lower charge of the battery. Observe ammeter and if there is not deflection, proceed with the following test.

7. Examine fuel line and pick-up for sealing at fittings.
8. Check and clean atmospheric vent holes.
9. Examine throttle and choke shafts for binding or excessive play – remove all dirt or paint, replace shaft.
10. Examine throttle and choke return springs for operation.
11. Examine idle and main mixture adjustment screws and “O” rings for cracks or damage.
12. Adjust main mixture adjustment screw. Check to see that it is the correct screw.
13. Examine main nozzle and replace with service nozzle.
14. Adjust idle mixture adjustment screw. Check to see that it is the correct screw.
15. Adjust idle speed screw.
16. Check position of choke and throttle plates.
17. Adjust control cable or linkage to assure full choke and carburetor control.
18. Clean carburetor after removing all non-metallic parts that are serviceable. Trace all passages.
19. Check inlet needle and seat for condition and proper installation.
20. Check sealing of welch plugs, cups, plugs and gaskets.
21. Check fuel pump operation – pulse pump, clean the pulse line after removing it from the pump & engine fittings.
22. Adjust governor linkage.
23. Adjust float setting.
24. Check float shaft for wear and float for leaks or dents.
25. Check seal for fuel drain or bowl gasket.
26. Is carburetor operating at excessive angle – 31° or more ?

# CHAPTER 11. SPECIAL TOOLS

No. 670195B - TOOL KIT. Contains 20 special tools commonly used in servicing 2 and 4-cycle engines.

Items preceded by a dagger (†) are part of this kit. All tools in kit are not displayed here.

## OIL SEAL DRIVER

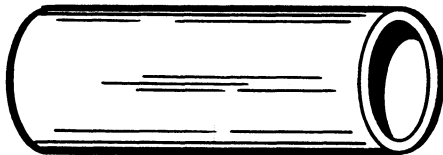

†No. 670272 - OIL SEAL DRIVER. Used with all oil seal protector-drivers to drive the seal into position.

## OIL SEAL DRIVER - PROTECTOR

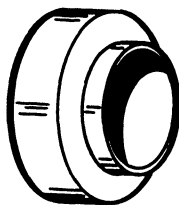

†No. 670260. Used on magneto and P.T.O. end of HH80-120, VH80-120 and OH120-180.

## FLYWHEEL PULLER

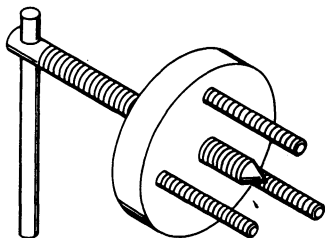

†No. 670218 Flywheel puller. Used on 8 H.P. and larger Lauson vertical and horizontal with flywheels that have drilled and tapped holes.

## FLYWHEEL TOOL



†No. 670217 Flywheel tool. Used on all Lauson vertical and horizontal engines.

## TAPER GAP GAUGE

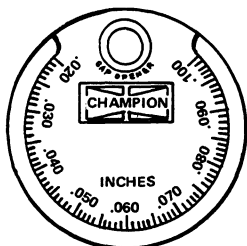

No. 670256 - Taper Gap Gauge

## 1/32" OVERSIZE GUIDE REAMER

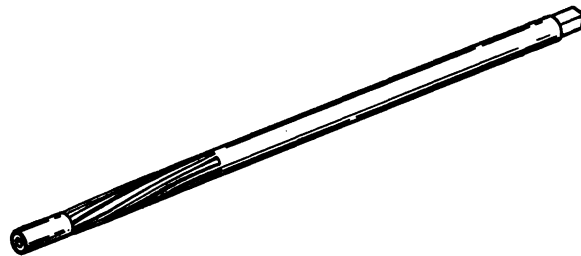

No. 670284. HH & VH80-120 and OH120-180

## VALVE SPRING COMPRESSOR FOR VALVE-IN-HEAD ENGINES

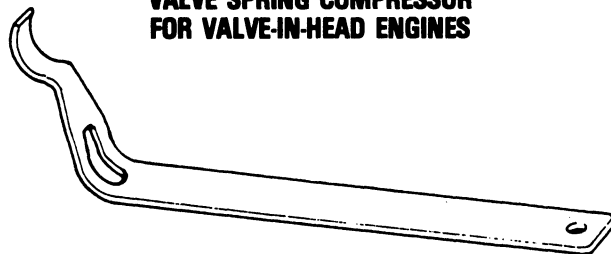

†No. 670237A Valve spring compressor for OH120-180.

## VIBRATION TACHOMETER

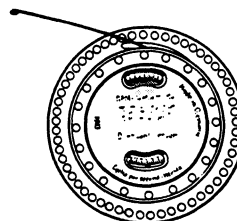

No. 670156 - Vibration Tachometer

## AIR GAP GAUGE

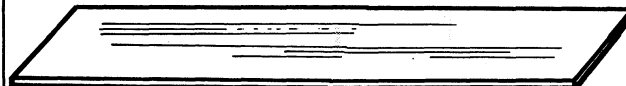

\*No. 670216 - Air gap gauge .0075 shim stock for setting air gap.

## VALVE LAPPING TOOL

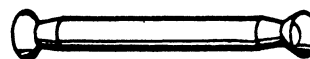

No. 670154 - Valve lapping tool

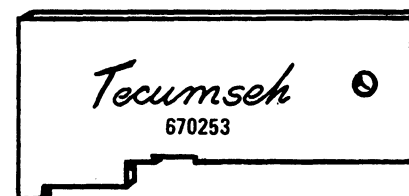

†No. 670253 - Carburetor Float Measuring Tool

25. Remove the throttle rod from the governor shaft.

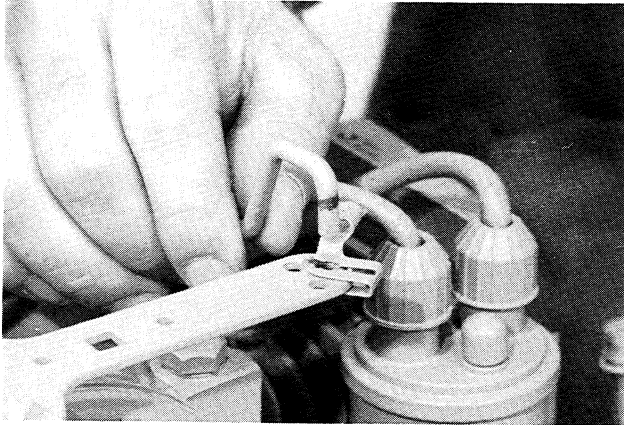
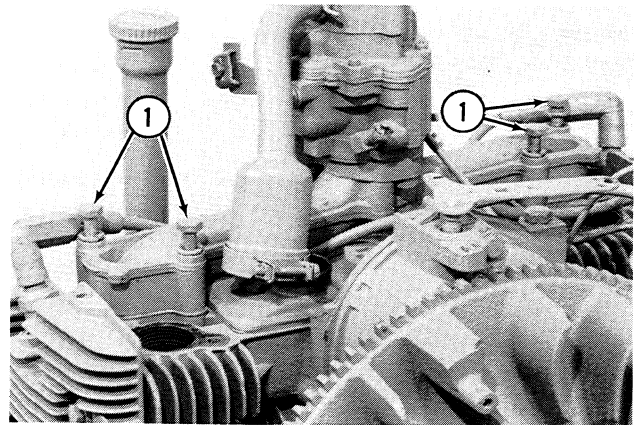

Figure 34

28. Remove the four cap screws and lock washers which fasten the intake manifold to the engine.



1. Cap Screw

Figure 37

26. Loosen the clamp which fastens the breather tube to the LH valve cover.

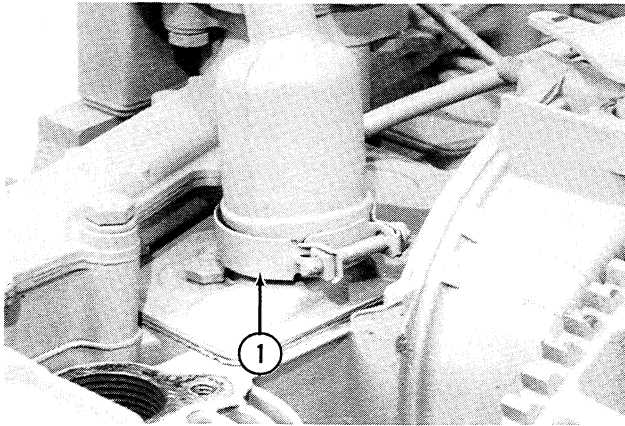

1. Clamp

Figure 35

29. Remove the carburetor and the intake manifold as an assembly.

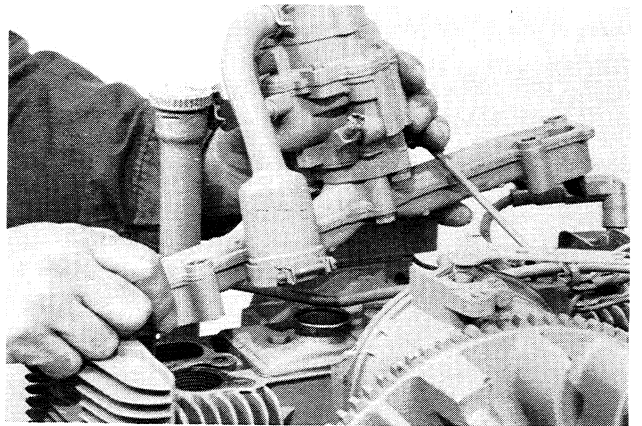
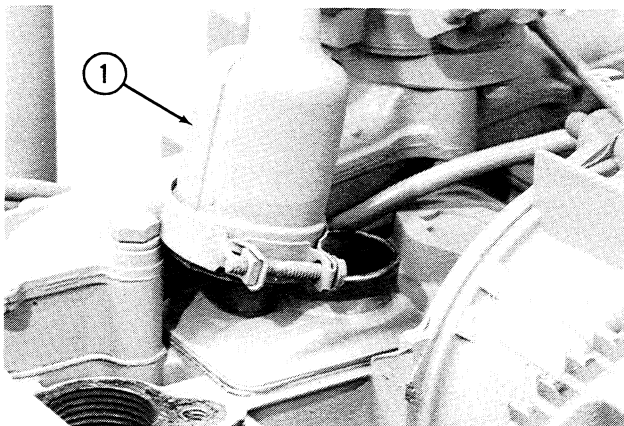

Figure 38

27. Remove the breather tube from the LH valve cover.



1. Breather Tube

Figure 36

30. Remove the intake manifold gaskets from the intake ports.

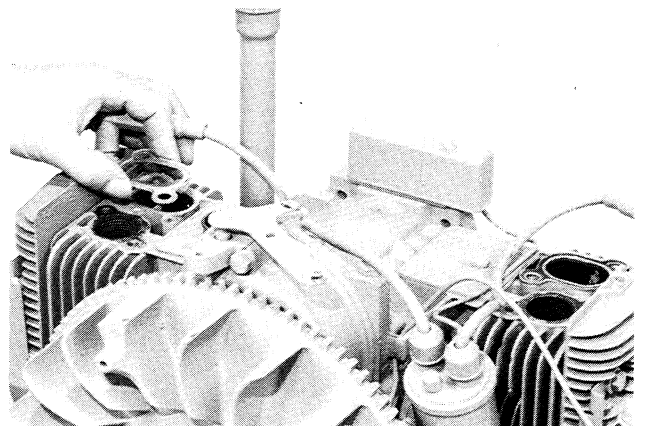
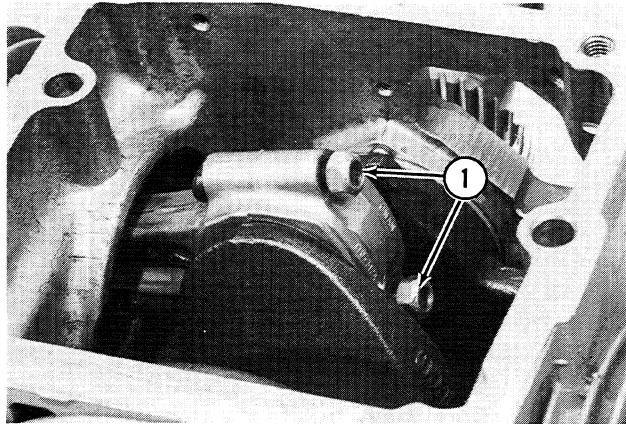

Figure 39

86. Turn the engine block upside down on the bench. Turn the crankshaft as necessary to put number one connecting rod in the position shown in Figure 94. (Number one cylinder is the cylinder closest to the flywheel end of the engine.) Remove the self-locking nuts from the connecting rod bolts.



1. Self-Locking Nut

Figure 94

87. Remove the cap from the connecting rod.

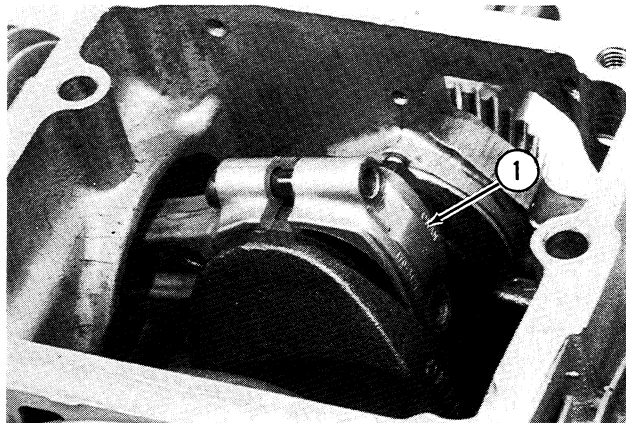

1. Cap

Figure 95

88. See Figure 96. Turn the crankshaft so that the crankshaft journal is away from the connecting rod. Use an acceptable tool, such as a hammer handle, to push the piston and connecting rod out of the cylinder. Be careful so that you do not damage the parts.

**NOTE:** If the pistons and connecting rods are to be used again, be sure to keep the parts of each assembly together and install identification tags so that the parts can be installed in the same locations during assembly.

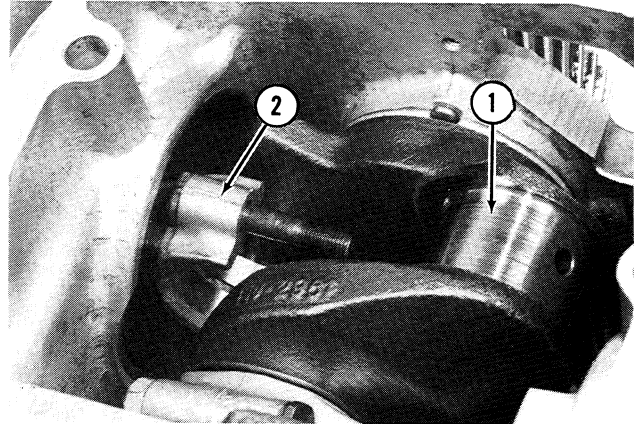

1. Crankshaft Journal  
2. Connecting Rod

Figure 96

89. Turn the crankshaft as necessary to put number two connecting rod in the position shown in Figure 97. Remove the self-locking nuts from the connecting rod bolts.

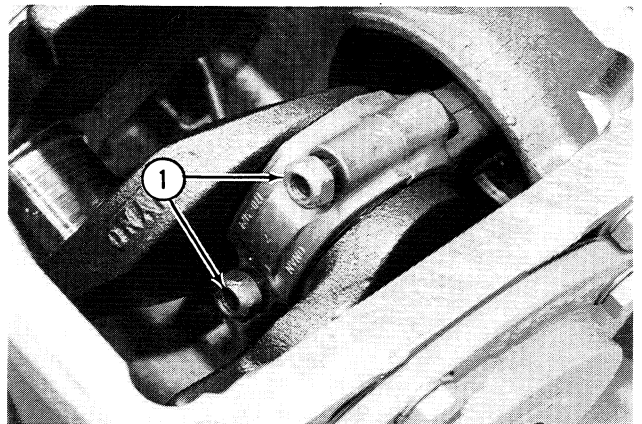

1. Self-Locking Nut

Figure 97

90. Remove the cap from the connecting rod.

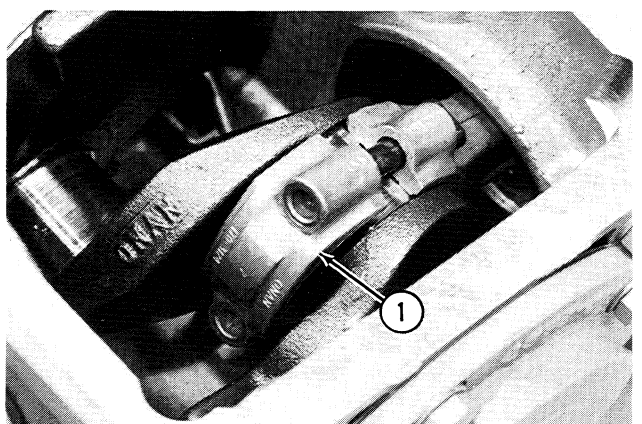

1. Cap

Figure 98

## Engine Block

Check the engine block for cracks. Very small cracks can be found by applying a mixture of 25% kerosene and 75% light motor oil. Wipe the area dry and immediately apply a solution of zinc oxide (white lead) in wood alcohol. If there are cracks, the cracks will cause a change of color in the damaged area.

Check the cylinder bores for scoring.

Check the expansion plug at the front camshaft bearing to make sure that the expansion plug fits tightly.

Check for cracks or breaks in the cooling fins.

Measure each cylinder bore for wear, taper, and run-out. Measure each cylinder bore at four places, two measurements at 90 degree angles at the top of piston ring travel and two measurements at 90 degree angles at the bottom of piston ring travel.

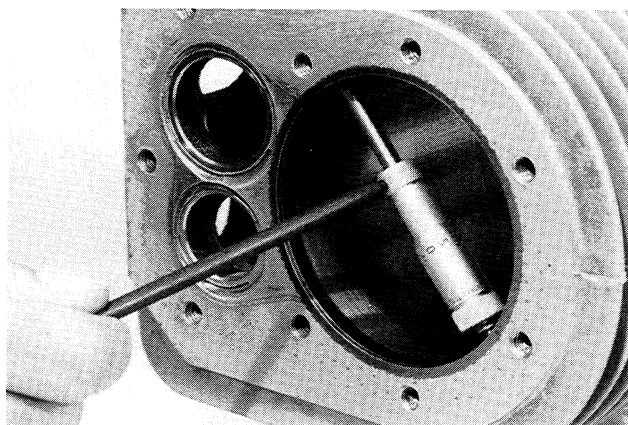

Figure 137

Compare the top measurements with the bottom measurements to find the amount of taper. Maximum permitted taper is .005 inch (0.13 mm). If measured taper is larger, the diameter of the cylinder bore must be increased and the next oversize piston installed.

Compare each pair of measurements at the same height to find the amount of run-out. Maximum permitted run-out is .002 inch (0.05 mm). If measured run-out is larger, the diameter of the cylinder bore must be increased and the next oversize piston installed.

Piston clearance is measured .10 inch (2.5 mm) below the oil control ring, 90 degrees from the piston pin. Piston clearance must be .004 to .006 inch (0.10 to 0.15 mm).

See Section 1003 for standard piston and cylinder bore sizes. See the Parts Catalog for available oversize pistons.

## Crankshaft

Use solvent to clean the crankshaft. Use compressed air to remove the solvent from the oil passages. Make sure that all obstructions are removed from the oil passages. Check for ridges and scoring on the crankshaft journals. If there is scoring, grind the crankshaft.

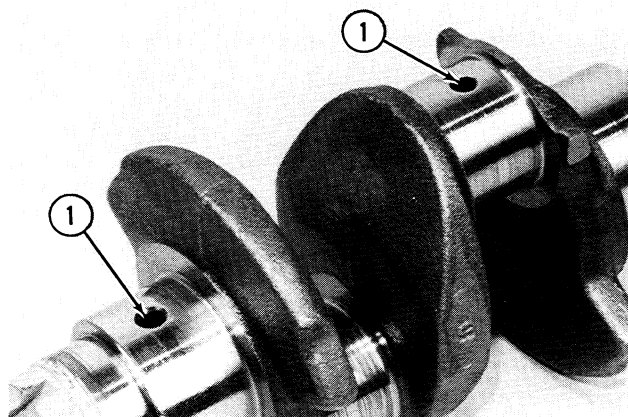

1. Oil Passage

Figure 138

Check the keys and keyways for wear, peening, looseness, and other damage. It is recommended that new keys be installed during assembly.

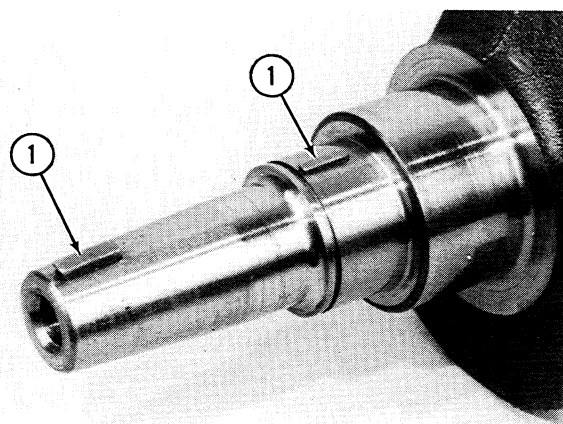

1. Key

Figure 139

Measure each crankshaft journal in at least four places to find the amount of wear, run-out, and taper. If the wear is more than .002 inch (0.05 mm) beyond the specifications in Section 1003, grind the crankshaft. If taper is more than .001 inch (0.03 mm) or run-out is more than .005 inch (0.13 mm), grind the crankshaft. See the Parts Catalog for available undersize bearings and connecting rods.

14. Put clean oil on the new rear crankshaft seal. Put the rear crankshaft seal in place as shown in Figure 183.

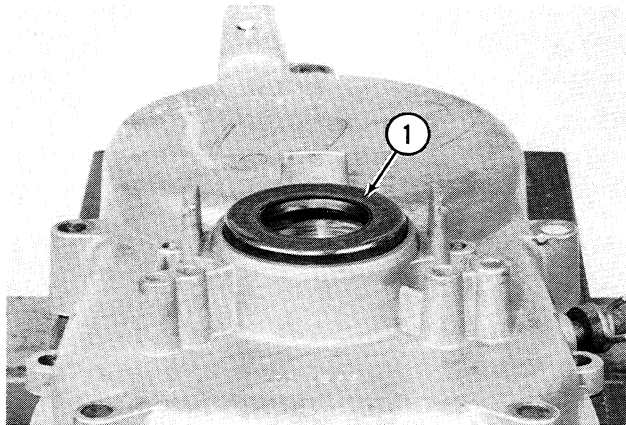

1 Rear Crankshaft Seal

Figure 183

15. Use the special tools shown in Figure 6 and Figure 9 between the press and the rear crankshaft seal. Press the rear crankshaft seal until the special tool touches the gear cover.

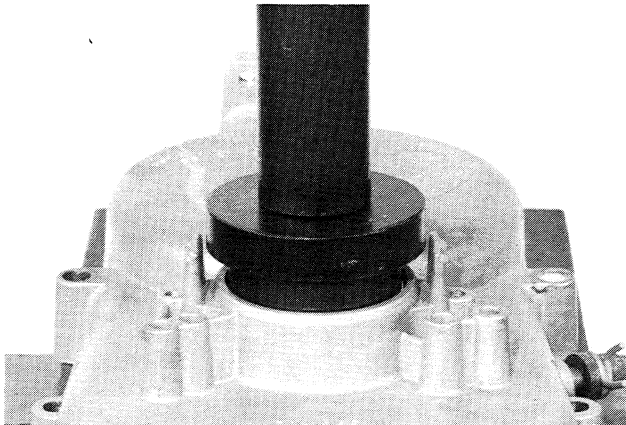
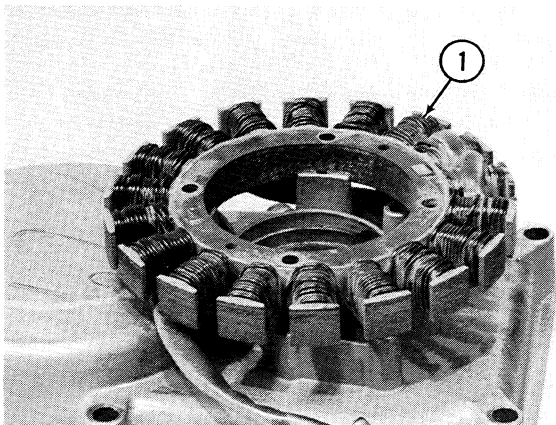

Figure 184

16. Put the stator in place on the gear cover.



1. Stator

Figure 185

17. Use the three screws and lock washers to fasten the stator to the gear cover.

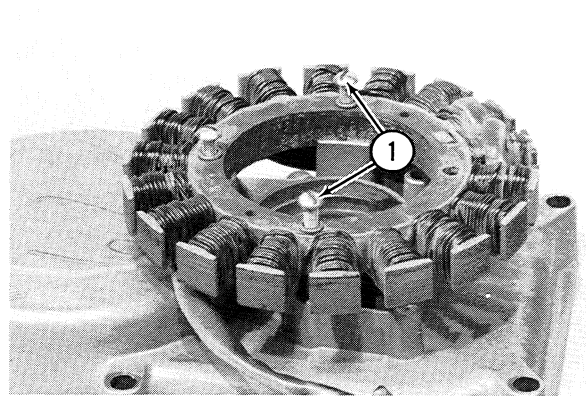

1. Screw

Figure 186

18. Install the steel ball in the bore for the governor shaft.

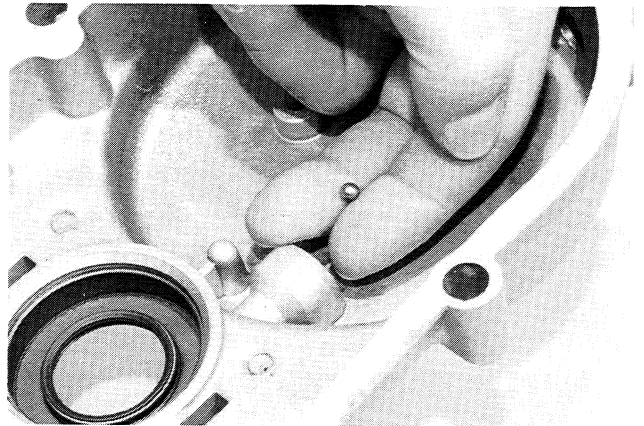

Figure 187

19. Put clean oil on the governor shaft. Install the governor shaft in the gear cover.

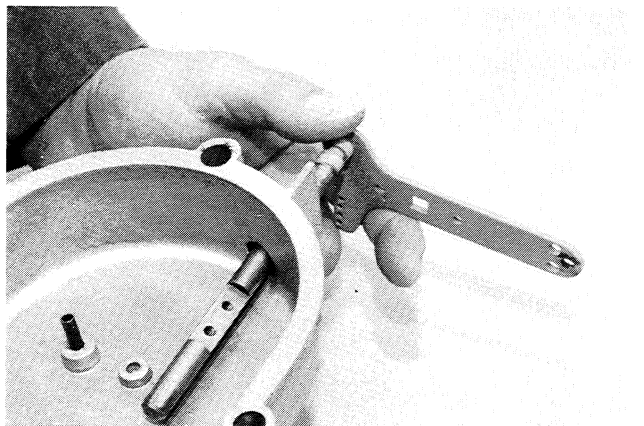

Figure 188

78. Install the snap ring which holds the gear retaining washer on the crankshaft.

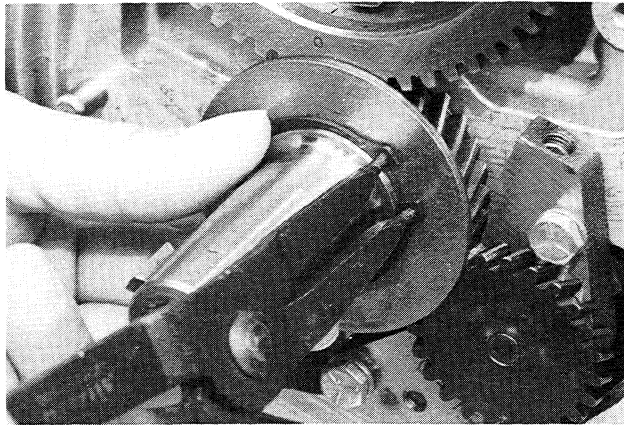

Figure 236

81. Install the hub and the governor cup on the camshaft center pin.

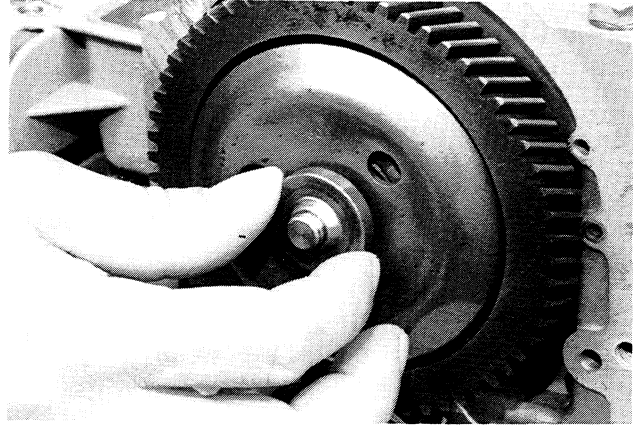
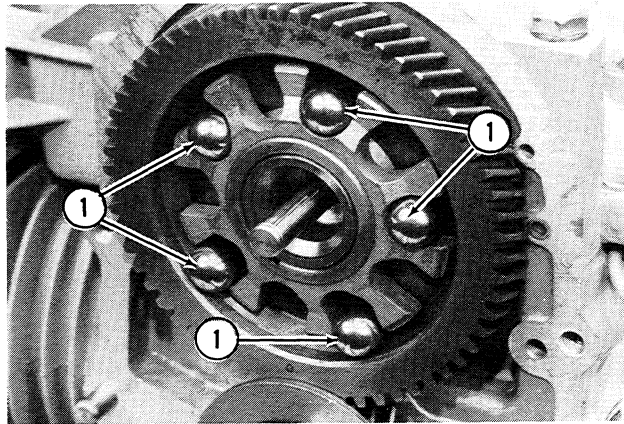

Figure 239

79. Install the five steel balls in the ball spacer. Install the steel balls in every other hole.



1. Steel Ball

Figure 237

82. Install the retaining ring in the groove in the camshaft center pin.

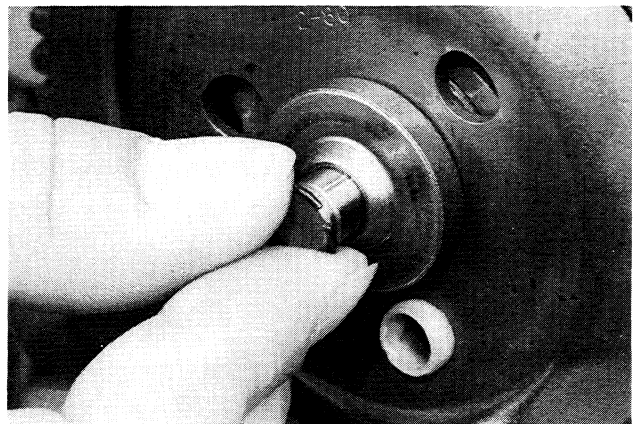

Figure 240

80. Install the hub in the governor cup.

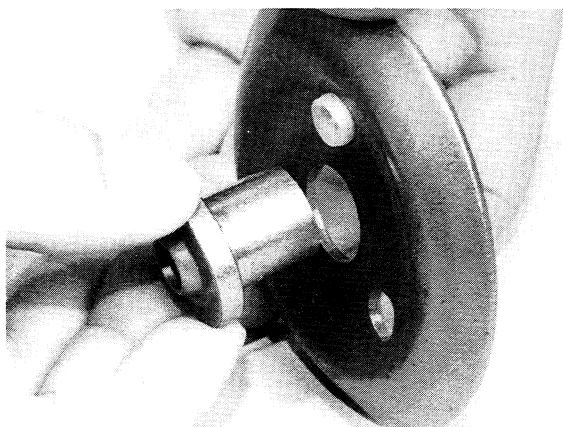

Figure 238

83. Install a new breaker box gasket on the engine.

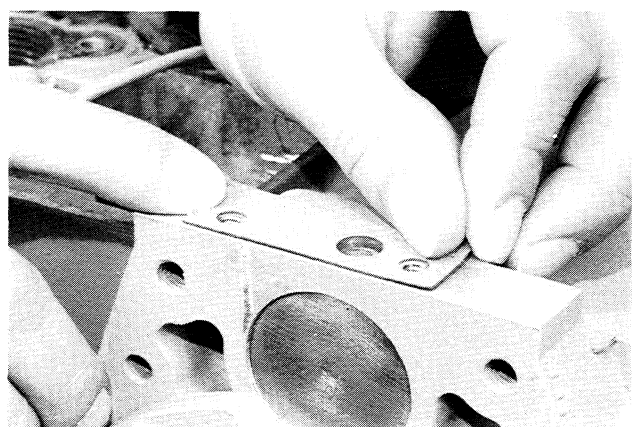
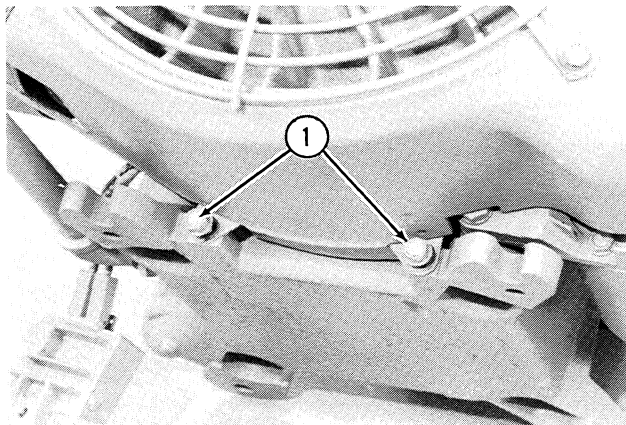

Figure 241

136. Install the two cap screws which fasten the bottom of the flywheel housing to the oil pan. Install the cap screw which fastens the top of the flywheel housing to the gear cover.

**NOTE:** The cap screws for the flywheel housing can be either 7/16 inch or 1/2 inch (11 mm or 13 mm) in length. There are no flat washers used with these cap screws. The cap screws for the LH and RH air housings are 5/8 inch (16 mm) in length and are used with flat washers. Make sure that you do not use the longer air housing cap screws when you install the flywheel housing. Using a longer cap screw in the top of the flywheel housing can cause engine damage.



1. Cap Screw

Figure 290

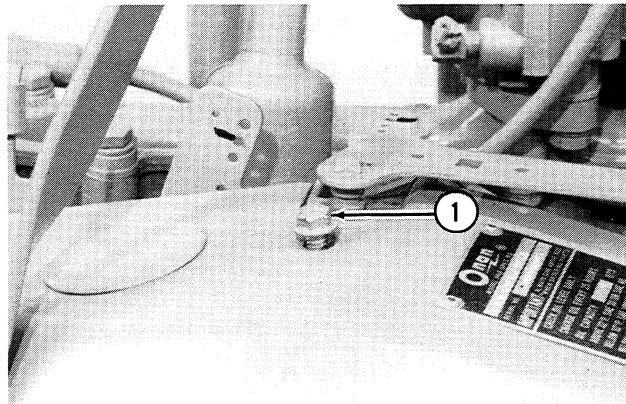

1. Cap Screw

Figure 291

137. Put the voltage regulator in place in the flywheel housing.

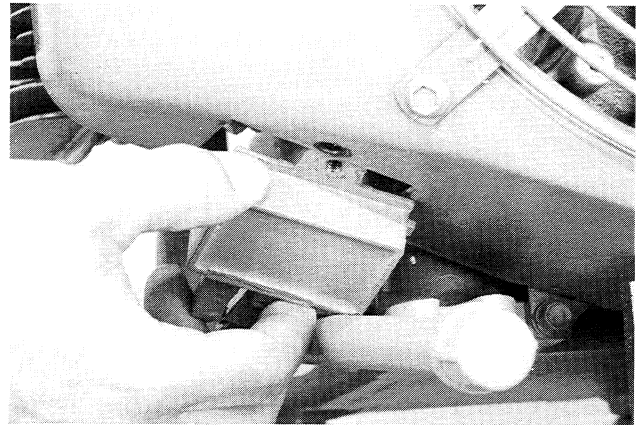
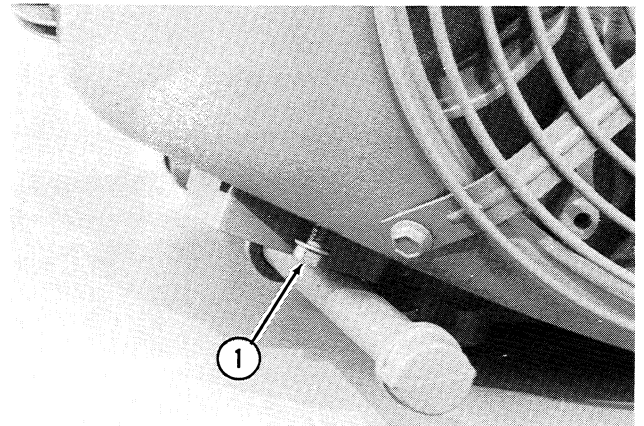

Figure 292

138. Install the cap screw to fasten the voltage regulator to the flywheel housing.



1. Cap Screw

Figure 293

139. Connect the spring to the governor arm and the governor shaft.

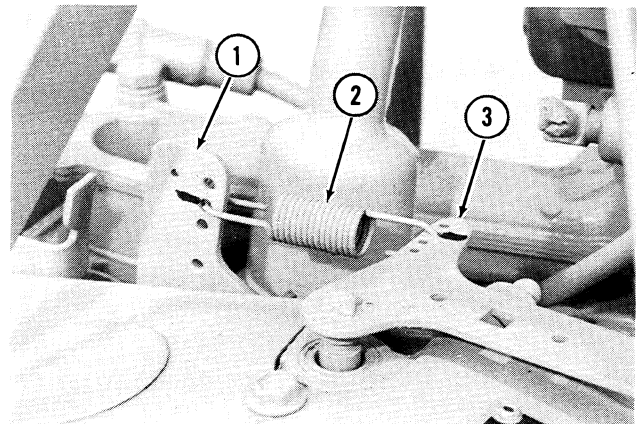

1. Governor Arm
2. Spring
3. Governor Shaft

Figure 294

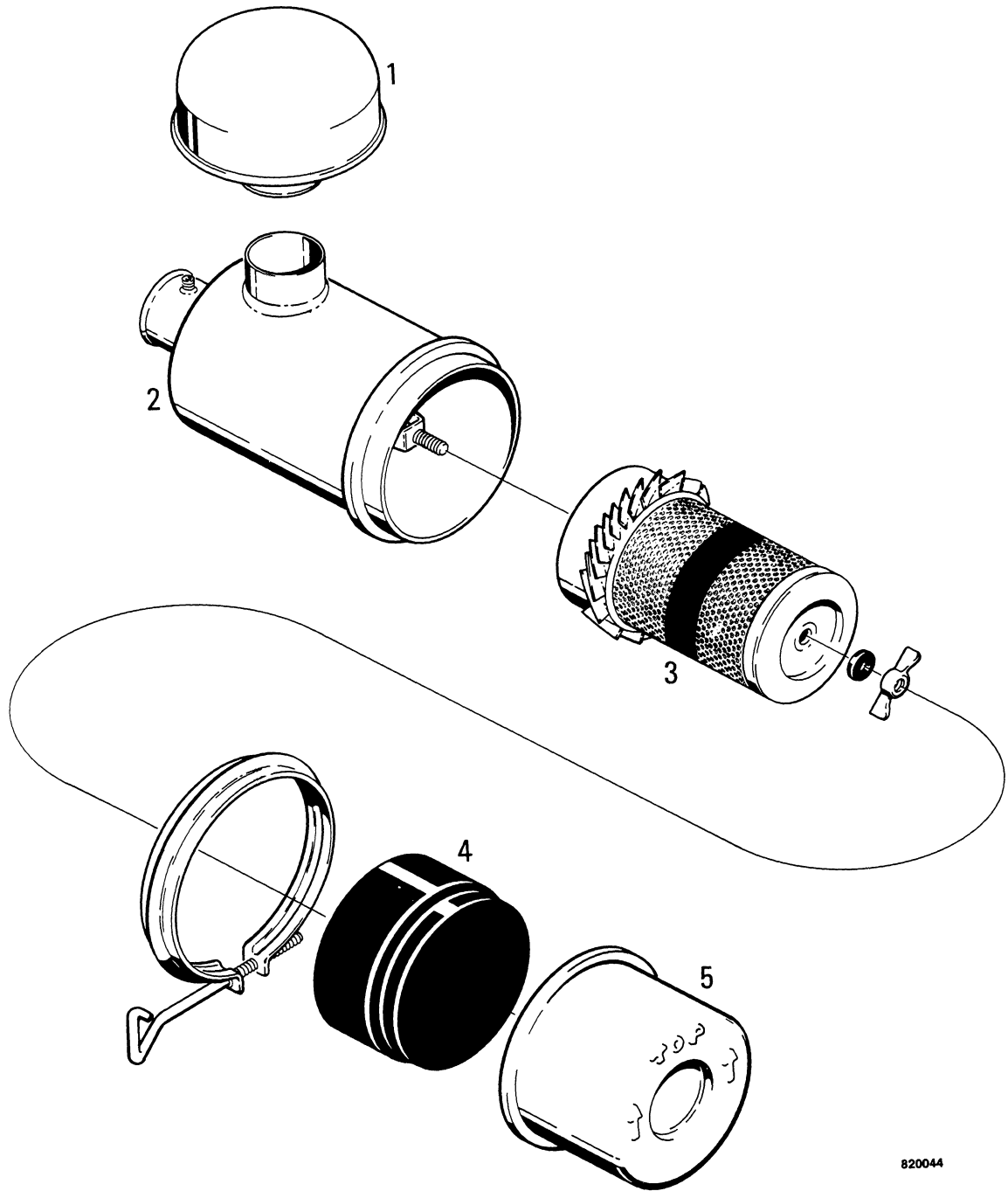

- 1. Air Cleaner Cap
- 2. Body
- 3. Filter

- 4. Baffle
- 5. Dust Cup

820044

Figure 1 - Optional Air Cleaner - 1816B

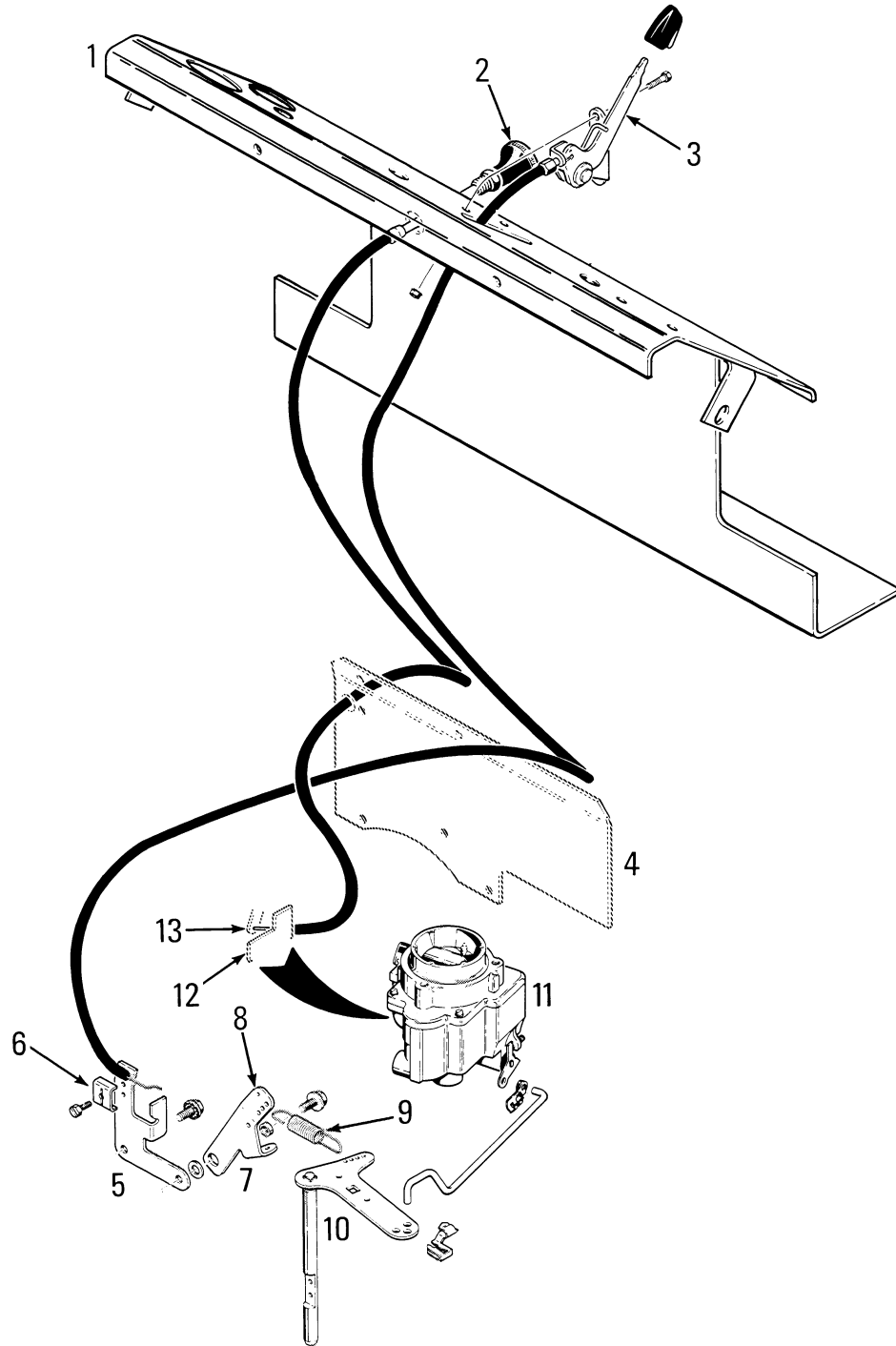

811332

- |  |                                      |
|--|--------------------------------------|
| 1. Instrument Panel                    | 8. Connect Throttle Cable Here       |
| 2. Choke Control                       | 9. Spring                            |
| 3. Throttle Control                    | 10. Governor Shaft and Arm           |
| 4. Heat Shield                         | 11. Carburetor                       |
| 5. Mounting Bracket for Throttle Cable | 12. Mounting Bracket for Choke Cable |
| 6. Clamp for Throttle Cable            | 13. Arm on Choke Shaft               |
| 7. Governor Control Arm                |                                      |

Figure 2 - Choke, Throttle, and Governor Linkage - 1816C

5. Remove the throttle rod from the arm on the throttle shaft.

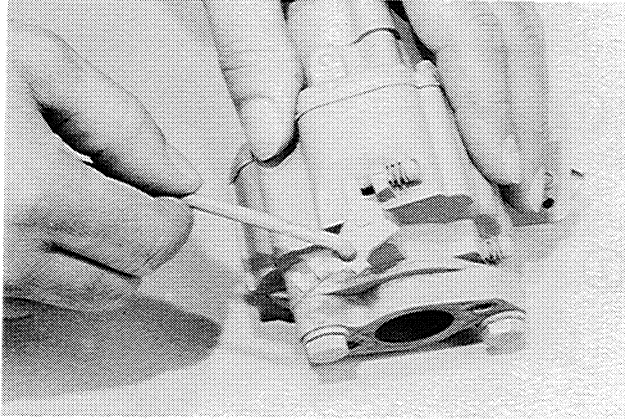

Figure 21

8. Remove the adapter plate from the carburetor body.

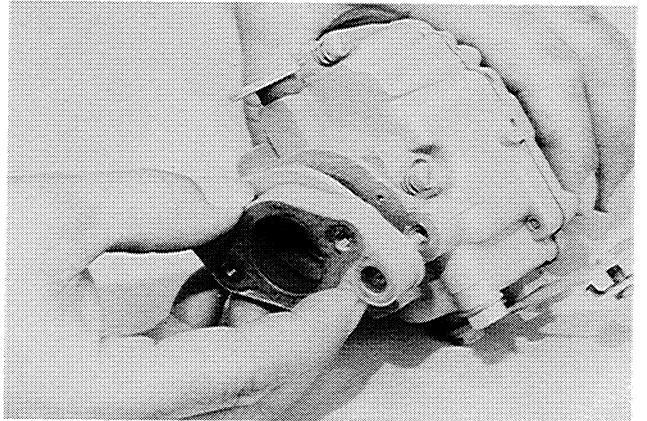

Figure 24

6. Remove the clip from the arm on the throttle shaft.

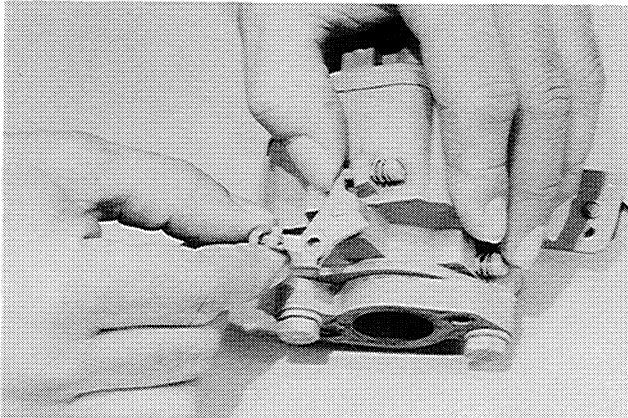

Figure 22

9. Remove the gasket from the adapter plate.

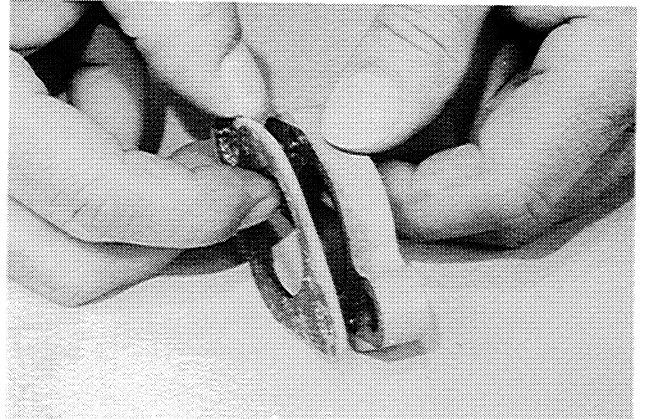
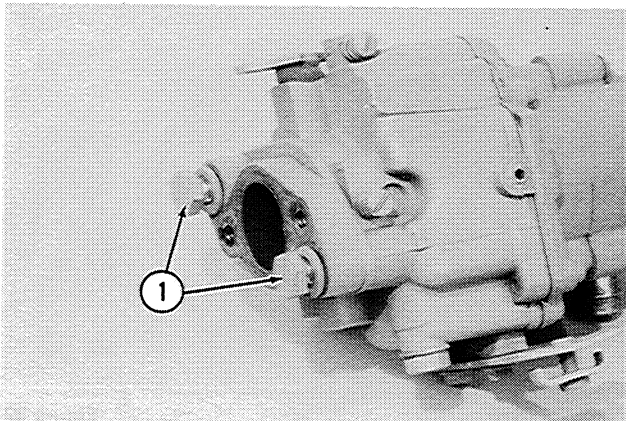

Figure 25

7. Remove the two cap screws and lock washers which fasten the adapter plate to the carburetor body.



1. Cap Screw

Figure 23

10. Remove the three screws and lock washers which fasten the adapter to the air intake housing.

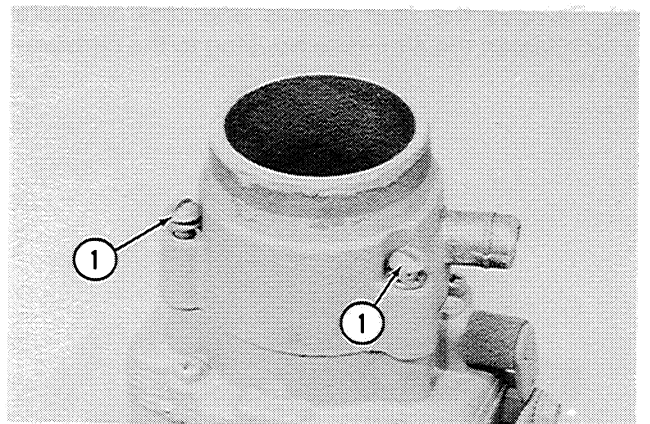

1. Screw

Figure 26

27. Put the adapter in place on the air intake housing.

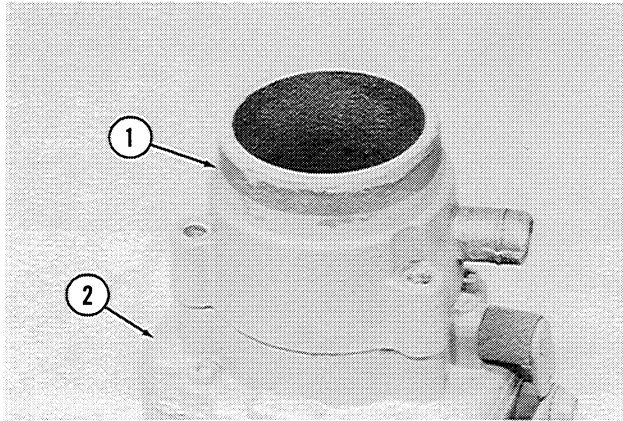

- 1. Adapter
- 2. Air Intake Housing

Figure 76

28. Install the three screws and lock washers which fasten the adapter to the air intake housing.

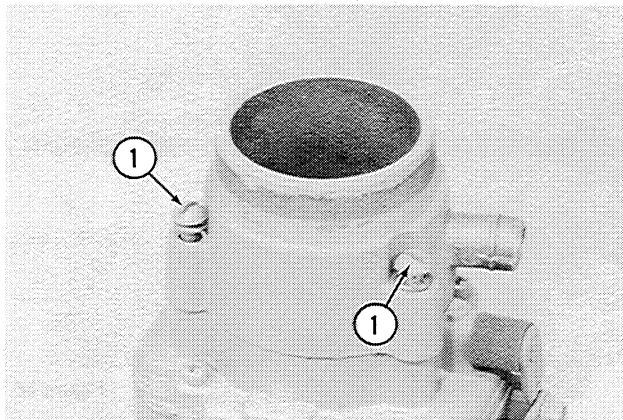

- 1. Screw

Figure 77

29. Install the gasket on the adapter plate.



Figure 78

30. Put the adapter plate and the gasket in place on the carburetor body.

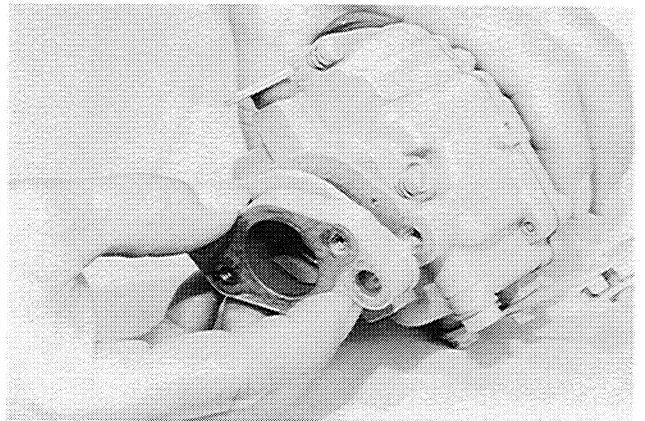
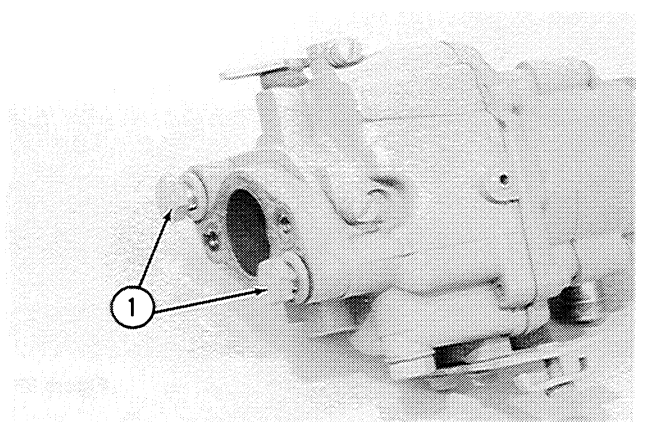

Figure 79

31. Install the two cap screws and lock washers which fasten the adapter plate to the carburetor body. Tighten the cap screws to a torque of 5 - 7 pound-feet (7 - 9 N m).



- 1. Cap Screw

Figure 80

32. Install the clip on the arm on the throttle shaft.

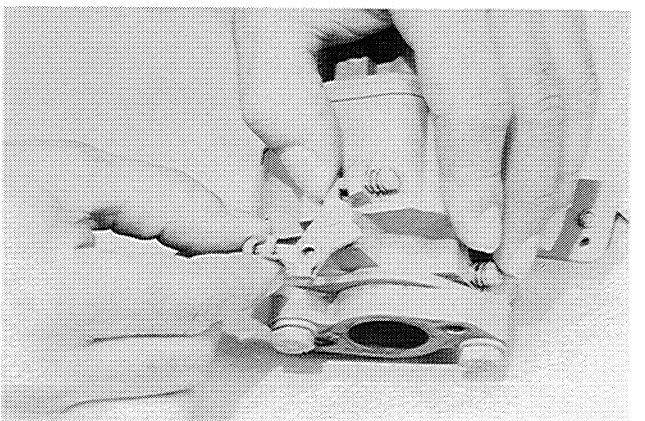

Figure 81

## ELECTRICAL SYSTEM SPECIFICATIONS

Type of system .....	12 volt, negative ground
Battery .....	One 12 volt battery
Alternator .....	12 volt, 20 ampere
Voltage regulator .....	12 volt, solid state construction, not adjustable
Starter .....	12 volt
Fuse for complete system .....	30 ampere
Fuse for backup alarm .....	14 ampere

19. If the voltage indication is more than .4 volt, install a new positive battery cable between the solenoid and the starter.

#### **Test No. 4 - Voltage Loss in the Negative Battery Cable**

1. Put the belt clutch control in the Off position and stop the engine.

2. Disconnect the wire from the rear terminal on the ignition coil. Put electrical tape over the end of the wire so that the wire does not make a ground to the machine.

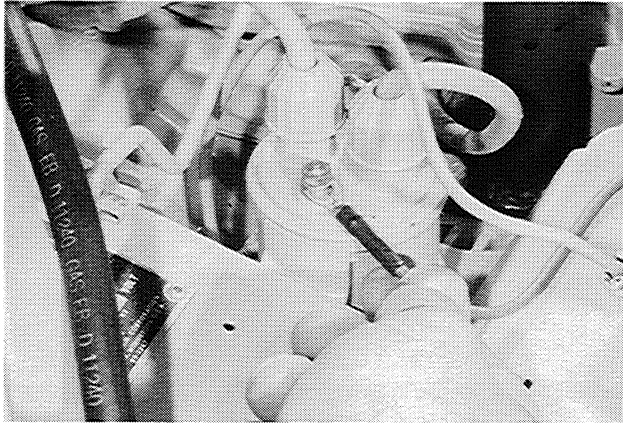

Figure 12

3. Select the lowest range on the voltmeter.

4. Connect the negative voltmeter lead to the connection for the negative battery cable at the battery.

5. Connect the positive voltmeter lead to the connection at the opposite end of the negative battery cable. (The connection is at the front RH engine mounting bolt.)

6. Hold the key switch in the ST position while you check the voltmeter indication. After you check the voltmeter indication, turn the key switch to the Off position.

7. If the voltmeter indication was more than .4 volt, replace the negative battery cable.

# Section 4003

## WIRING DIAGRAMS

Written In *Clear  
And  
Simple  
English*

# Section 4004

## GAUGES

Written In *Clear  
And  
Simple  
English*

## SPECIFICATIONS

Number and size .....	One 12 volt battery, negative ground, group size U1 with type "L" terminals
Capacity - 20 hour rate .....	32 ampere hours
Cold cranking rating .....	200 amperes at 0° F (-18° C) 150 amperes at -20° F (-29° C)
Reserve capacity .....	32 minutes
Capacity (load) test current .....	100 amperes
Full charge specific gravity .....	1.265 ±.005
Plates per cell .....	nine
Charging specifications .....	See page 4005-9
Weight with electrolyte .....	22 pounds (10 kg)

 **CAUTION:** *Disconnect the ground cable first when the battery cables are disconnected from the battery.*

*Connect the ground cable last when the battery cables are connected to the battery.* 47-55

 **CAUTION:** *Never cause sparks to occur or smoke near batteries that are charging or have been recently charged.* 13-8

 **CAUTION:** *Never wear rings or metal watch bands that may ground a live circuit.* 13-9

 **WARNING:** *Never use booster batteries to start the engine if the electrolyte in the battery on the machine is frozen.* 47-82-A

**POISON/DANGER:** *Battery acid causes severe burns. Batteries contain sulfuric acid. Avoid contact with skin, eyes, or clothing. Antidote: EXTERNAL-Flush with water. INTERNAL-Drink large quantities of water or milk. Follow with milk of magnesia, beaten egg, or vegetable oil. Call physician immediately. Eyes: Flush with water for 15 minutes and get prompt medical attention.*

*Batteries produce explosive gases. Keep sparks, flame, and cigarettes away. Ventilate when charging or using in enclosed area. Always shield eyes when working near batteries.*

*Keep out of reach of children.* D-47-53

 **WARNING:** *Never try to charge the battery if the electrolyte in the battery is frozen.* 47-83

CLICK HERE TO **DOWNLOAD** THE COMPLETE MANUAL

- Thank you very much for reading the preview of the manual.
- You can download the complete manual from: [www.heydownloads.com](http://www.heydownloads.com) by clicking the link below



- Please note: If there is no response to CLICKING the link, please download this PDF first and then click on it.

CLICK HERE TO **DOWNLOAD** THE COMPLETE MANUAL

# Section 4006

## STARTER - 1816C

Starter - 1816 and 1816B .....	See Sections 2001 and 2005
Alternator - 1816 and 1816B .....	See Sections 2001 and 2005
Alternator - 1816C .....	See Sections 2006 and 4002
Spark Ignition System - 1816 and 1816B .....	See Sections 2001 and 2005
Spark Ignition System - 1816C .....	See Sections 2006 and 4002

Written In *Clear  
And  
Simple  
English*

## INSPECTION

Clean the parts by wiping with a clean cloth or using compressed air. The bearings in the commutator end cap and the drive end cap can be cleaned using a brush and clean engine oil. DO NOT use solvent to clean the bearings, the armature, or the starter drive. If solvent is used to clean other parts, make sure that all solvent is removed before assembly.

### Bearings

There are bearings in the drive end cap and the commutator end cap. Inspect the bearings for wear, rough surfaces, or other damage. If a bearing is damaged, it is necessary to replace the complete end cap.

### Brushes and Brush Springs

1. If any brush is worn to a length shorter than 1/4 inch (6.4 mm), replace all the brushes.
2. Check to make sure that the brushes move smoothly in the brush holder.
3. Check the brush springs for distortion and for color changes because of too much heat. Replace any brush springs which are damaged.
4. Check to make sure that the brush springs have enough tension to hold the brushes against the commutator.

### Armature

1. To test the armature for grounds, connect one ohmmeter lead to the armature shaft and the other ohmmeter lead to the end of each commutator bar in sequence. Any low ohmmeter reading is an indication of a ground in the armature.

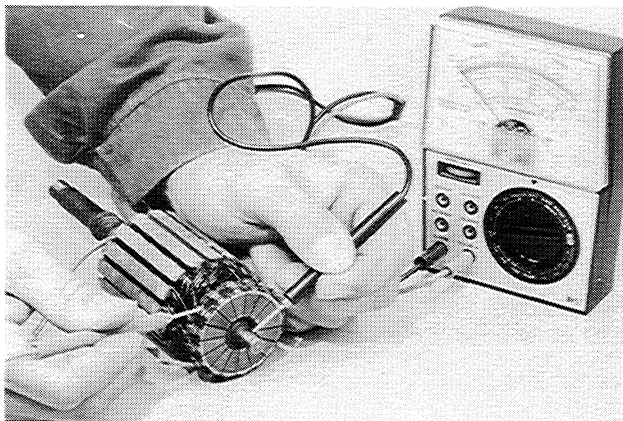

Figure 30

2. Use an armature tester to test the armature for short circuits. Use the instructions included with the armature tester.

3. Inspect the commutator for worn or burned areas. Inspect for rough or burned areas on the commutator bars. If these areas are found, use a lathe to remove material from the commutator bars until the commutator bars are clean and smooth. Clean any foreign material from the grooves between the commutator bars. Use 00 sandpaper to remove any rough edges from the commutator bars. DO NOT use emery cloth. Check for loose connections between the commutator bars and the armature.

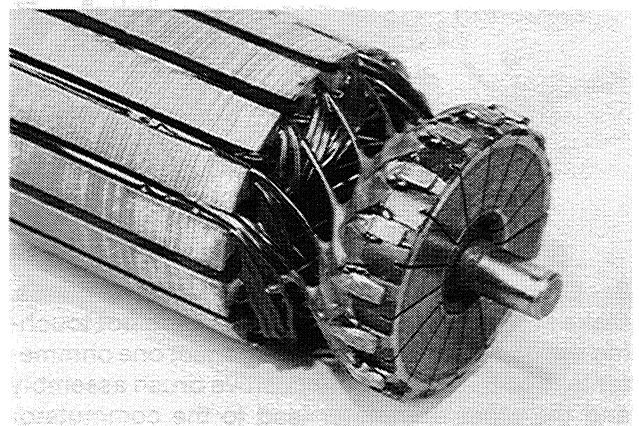

Figure 31

4. Inspect the armature shaft for rough bearing surfaces and rough or damaged splines.

### Starter Drive

Use a clean, dry cloth to clean the starter drive. Do not use cleaning solvent. Inspect the splines in the starter drive for wear or damage. Check to make sure that the starter drive moves freely on the splines of the armature shaft.

SYMPTOM	POSSIBLE CAUSE	REMEDY
Malfunction occurs in both directions of travel (cont'd)	Defect in pump rotating group. Defect in motor.	Refer to remedy no. 6. Remove motor, disassemble and check for cause.
Malfunction is intermittent	Defect in soft-ride valve.	Refer to remedy no. 5.
Malfunction occurs under light load	Tow valve stem pushed in or defective parts. Leaking high pressure check valve. Defect in soft-ride valve. Charge pump check valve not seating.	Refer to remedy no. 1. Refer to remedy no. 3. Refer to remedy no. 5. Remove check valve(s) and check for cause. It may be necessary to disconnect some hoses to gain easy access to check valve plugs.
Malfunction occurs regardless of load	Tow valve stem pushed in or defective parts. Low charge pressure. Defective or improperly adjusted high pressure relief valve. Defect in soft-ride valve. Defect in pump rotating group. Defect in motor.	Refer to remedy no. 1. Refer to remedy no. 2. Refer to remedy no. 4. Refer to remedy no. 5. Refer to remedy no. 6. Remove motor, disassemble and check for cause.
Malfunction occurs at maximum vehicle speed	Low charge pressure. Defect in motor.	Refer to remedy no. 2. Remove, disassemble and check for cause.
Malfunction occurs at minimum vehicle speed	Low charge pressure. Defect in pump rotating group. Defect in motor.	Refer to remedy no. 2. Refer to remedy no. 6. Remove motor, disassemble and check for cause.
Malfunction occurs regardless of vehicle speed	Tow valve stem pushed in or defective valve parts. Low charge pressure.	Refer to remedy no. 1. Refer to remedy no. 2.

## Problems in a Single Hydrostatic Circuit

PROBLEM	POSSIBLE CAUSE	CORRECTION
Machine moves forward or backward when control lever is in Neutral.	Control linkage not adjusted correctly.	Adjust control linkage according to the instructions in Section 6008 or Section 6009.
Machine moves in one direction only.	Problem in check valve for closed loop circuit.	If problem is in Forward, remove left hand plug, spring, and ball from front of pump end cap and check for damaged parts. Remove right hand plug if problem is in Reverse.
Loss of power or failure to move in either direction	<p>Disconnected control linkage.</p> <p>Defect in piston pump or hydrostatic motor.</p>	<p>Remove seat and heat shield assembly and check for missing clevis pins or ball joint retaining nuts.</p> <p>Check charge pressure according to the instructions in this section.</p> <p>If the charge pressure is correct, the two most probable causes of the problem are damage to the hydrostatic motor or broken motor sprocket splines. Before you remove the hydrostatic motor, move the control lever in both directions and check to make sure that both swash plate trunnions move. If the outside swash plate trunnion does not move, the roll pins which fasten the inside swash plate trunnion to the swash plate are broken. Remove the piston pump and repair as necessary. If the outside swash plate trunnion moves when you move the control lever, the piston pump is good.</p> <p>If the charge pressure is not correct, the problem is in the charge pump, the charge pump relief valve, or the rotating group. Before you remove the piston pump, remove the parts of the charge pump relief valve and check for defects. If there is no problem in the charge pump relief valve, remove the piston pump and repair or replace as necessary.</p>

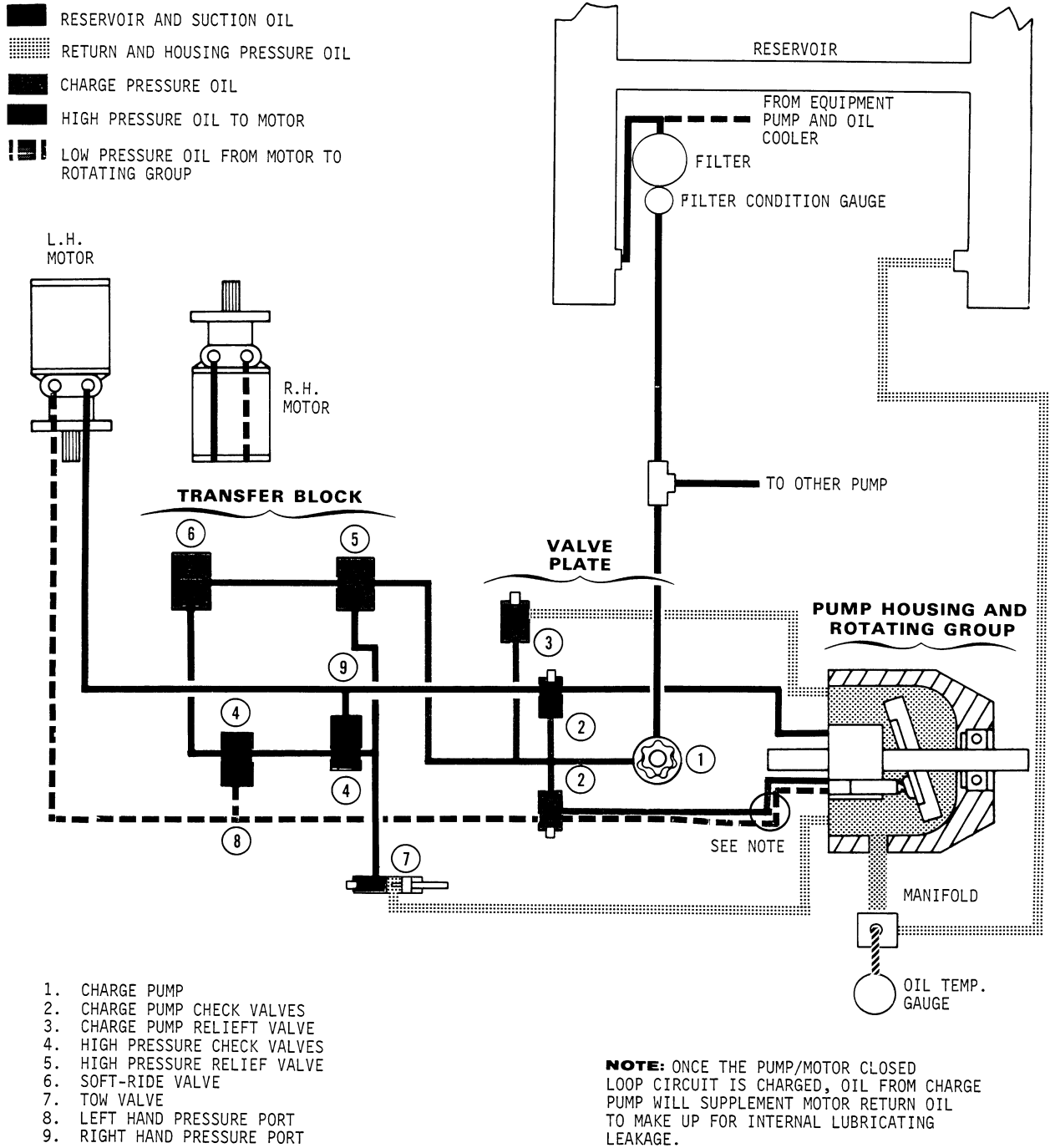

810412

Figure 2 - Oil Flow, Right Side Forward or Left Side Reverse

## OPERATION

### General Information

The hydrostatic system on this machine includes two closed loop circuits: (1), the drive circuit for the right hand wheels and (2), the drive circuit for the left hand wheels. The closed loop circuits are shown in Figure 1 and Figure 2.

Each closed loop circuit includes a piston pump, a hydrostatic motor, and the necessary hydraulic lines. The hydrostatic system and the equipment hydraulic system use a common hydraulic reservoir. There is a charge pump in each piston pump. The charge pump is between the housing and the mounting flange of the piston pump.

During normal machine operations, the engine is run at full throttle. Speed and power of the machine are then controlled by the piston pumps. When the steering control levers are moved forward or rearward, the piston pumps start to work. Maximum movement of the steering control levers causes maximum travel speed and minimum power. A smaller movement of the steering control levers causes more power but less travel speed.

### Piston Pump

Each piston pump has a rotating group which includes the piston block and the pistons. The rotating group is turned by the pump shaft. The amount of oil moved by the piston pumps is controlled by the angle of the swash plate, which is connected by linkage to the steering control levers.

Each piston pump has a charge pump between the housing and the mounting flange of the piston pump. The rotating group is charged with oil by the charge pump. The relief valve for the charge pump controls the pressure of the oil sent to the rotating group.

The lubricating and return oil comes from passages in the pistons and from leakage between parts of the rotating group. Oil which leaves the closed loop circuit in this way is replaced by the charge pump.

### Oil Flow During Operation

See Figure 2. Oil from the charge pump is sent to the low pressure side of the rotating group through one of the two check valves in the end cap. The other check valve is held closed by oil from the high pressure side of the rotating group.

Oil flow between the piston pump and the hydrostatic motor is a closed loop circuit. Lubricating and return oil leaving the closed loop circuit is replaced as required by the charge pump. The quantity of oil flow is controlled by the pump shaft speed and the angle of the swash plate. The direction of the oil flow is controlled by the direction in which the swash plate is moved forward or rearward from neutral.

### Hydrostatic Motor

See Figure 5. The main parts of the hydrostatic motor are the housing; the gerotor, which turns the drive link and the coupling shaft; the manifold plate, which sends oil to the gerotor; the manifold; and the commutator, which controls the direction of pressure and return oil.

The gerotor includes the stator, the rotor, and seven rollers. The rotor has six lobes, one less than the number of rollers, in order to make the pockets necessary for the hydrostatic motor to work.

### How Oil from the Piston Pump Turns the Hydrostatic Motor

1. In this example the oil from the piston pump enters the front port of the left hand hydrostatic motor.
2. The oil flows through drilled passages in the coupling shaft and along the drive link to the commutator.
3. Splines on one end of the drive link fit the splines in the rotor. Splines on the other end of the drive link fit the splines in the coupling shaft. The commutator fits over the end of the drive link and moves on the face of the manifold.

## Disassembly

1. Remove the transfer block/valve plate assembly by removing two Allen head screws, and then the two hex head screws, Figure 3.

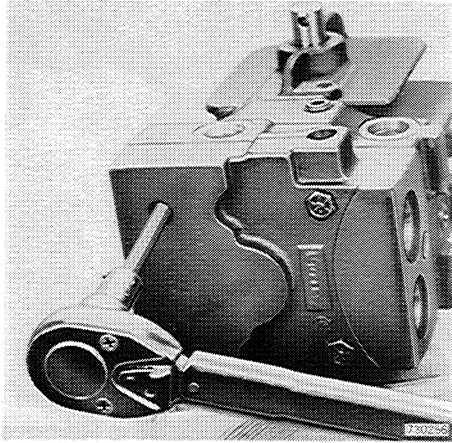

Figure 3

2. Pull the transfer block/valve plate assembly straight up from housing. If necessary, tap the valve plate with a soft hammer to break seal between parts and dislodge valve plate from locating pins.

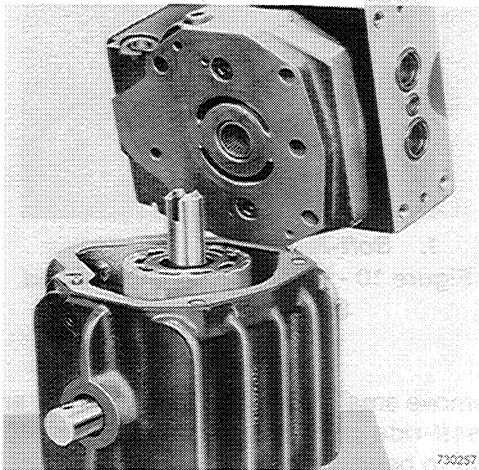

Figure 4 - Transfer Block/Valve Plate Removed

3. To remove valve plate from transfer block, remove two Allen head screws, Figure 5.

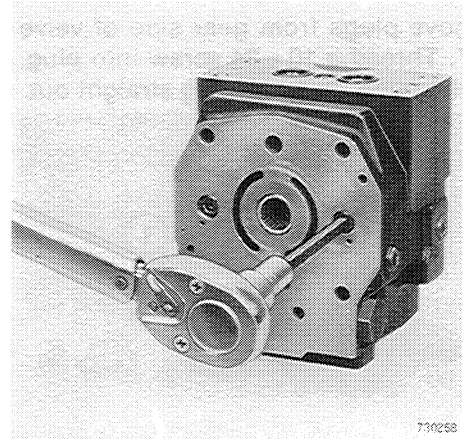

Figure 5

4. Separate valve plate from transfer block by tapping top and bottom of valve plate with a soft hammer, Figure 6. **DO NOT** pry apart as damage to machined surfaces could result.

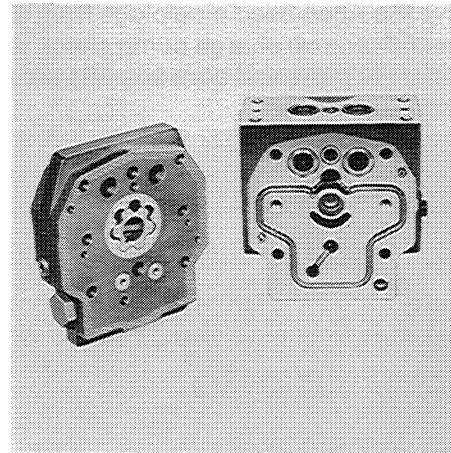

Figure 6 - Valve Plate and Transfer Block

5. Remove gear and gear ring from valve plate.

9. Connect hoses to right hand pump. Hose from right motor front port to long elbow and remaining hose to short elbow.
10. Connect inlet hose to pump. Then connect equipment pump outlet hose.
11. Route throttle cable through hole in pump mounting plate and connect to carburetor.
12. Fill hydraulic reservoirs with oil specified in Section 1002.
13. Fill pumps before starting engine. Remove spark plug wire and operate starter for 30 seconds, wait one minute and operate starter again for 30 seconds.
14. Raise all wheels off the floor and block machine in place.
15. Connect spark plug wire and start engine. With engine running at low idle, crack both lines at each motor to bleed air from lines.
16. With engine running at low idle, slowly move each control lever completely forward and rearward. Increase engine speed to full throttle and move control levers completely forward and rearward.
17. Stop engine, check for leaks and check reservoir oil level.
18. Install floorboard and seat/heat shield assembly.

#### **Method No. 2**

1. Make sure drain hose is installed on pump.
2. Install adapter plate on pump and torque capscrews to 25 - 35 pound-feet (34 - 47 N m). Slotted end of plate must be to the right viewing pump from drive end.
3. Install pump on mounting plate and tighten mounting bolts. Then install sheave on driveshaft with long end of hub away from pump. Position sheave on shaft until space between pump mounting plate and sheave measures .100 inch (2.54 mm); then tighten sheave set screws and install snap ring.
4. Install pump mounting plate in machine. As mounting plate is being positioned, have someone place hydrostatic belts on sheaves. Install mounting hardware and align plate with marks made during removal and tighten nuts. The pump mounting plate should be parallel to and about .100 inch (2.54 mm) from the clutch.
5. Check alignment of left hand pump sheave and drive sheave, and reposition pump sheave as required.
6. Adjust belts as instructed in Section 2003. Then install control rods.
7. Install adjustable elbows in left hand pump. Install short elbow with new O-ring in right hand port and the long elbow with new O-ring in the remaining port. Do not tighten elbow lock nuts until hoses have been connected.
8. Connect drain hoses to manifold and install control rods.
9. Install inlet tube and hose assembly.
10. Connect hose from left motor front port to long elbow. Position hose and tighten elbow lock nut. Connect hose from rear motor port to short elbow. Position hose and tighten elbow lock nut.
11. Connect hose from right motor front port to long elbow. Position hose and tighten elbow lock nut. Connect hose from rear motor port to short elbow. Position hose and tighten elbow locknut.
12. Connect hoses to equipment pump.
13. Connect lift cylinder hose to tees. Connect tubes to tees and control valve. The long tube is connected to the bottom tee and front control valve port. Secure hoses in place with clamps. Position hoses as instructed in Section 9001.
14. Route throttle and choke cables through hole in pump mounting plate and connect cables to carburetor.
15. Fill hydraulic reservoirs with oil specified in Section 1002.

25. See Figure 25. Put the housing on blocks so that the pump shaft is not in contact with the work bench.

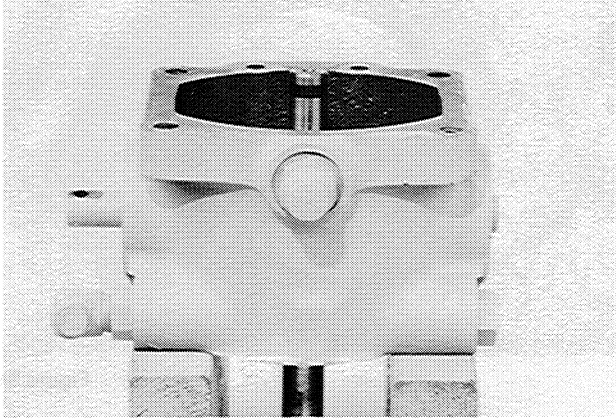

Figure 25

26. Use a 5/32 inch punch to drive the Spirol pins out of the swash plate and the trunnions. There are two Spirol pins in the side which has the long trunnion and one Spirol pin in the side which has the short trunnion. (See step 35.)

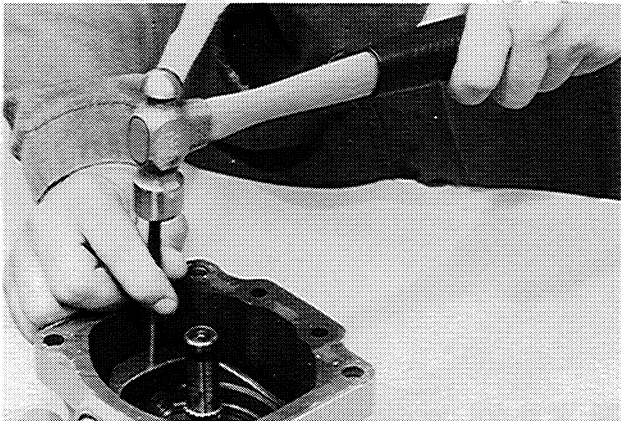

Figure 26

27. Use a prybar to remove the short trunnion from the swash plate and the housing.



Figure 27

28. Remove the special washer.

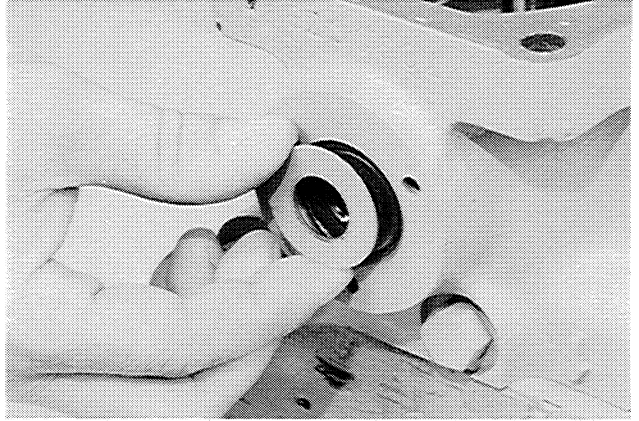

Figure 28

29. Use a prybar to remove the seal from the bore for the short trunnion.

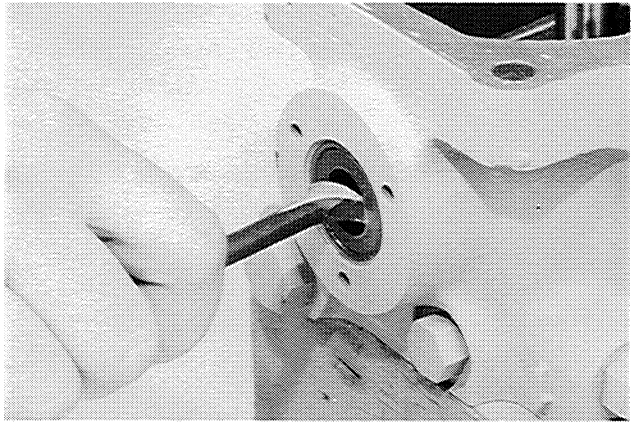

Figure 29

30. Use a prybar to remove the long trunnion from the swash plate and the housing.



Figure 30

2. Use an acceptable tool to support the ball bearing on blocks on the press table as shown in Figure 71. Make sure that the snap ring end of the pump shaft is up.

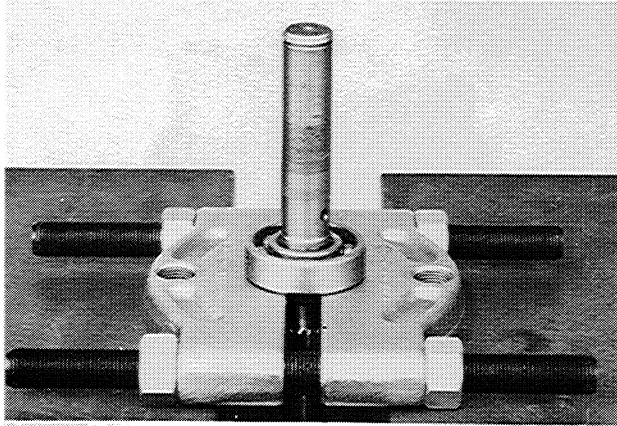

Figure 71

3. Press the pump shaft out of the ball bearing.

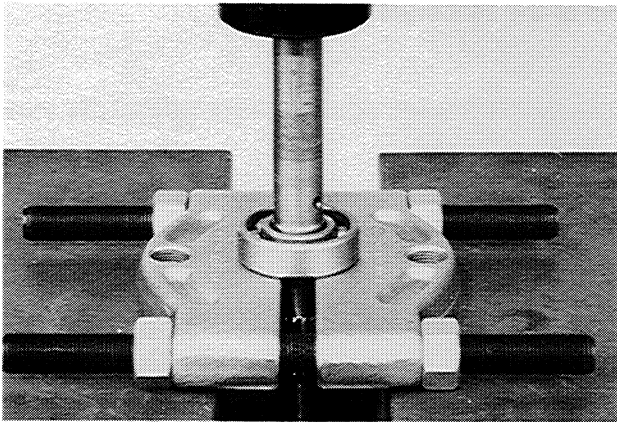

Figure 72

4. Put clean oil on the inner surface of the new ball bearing. Put the new ball bearing on the tool as shown in Figure 73. Make sure that the tool supports the inner race of the ball bearing.

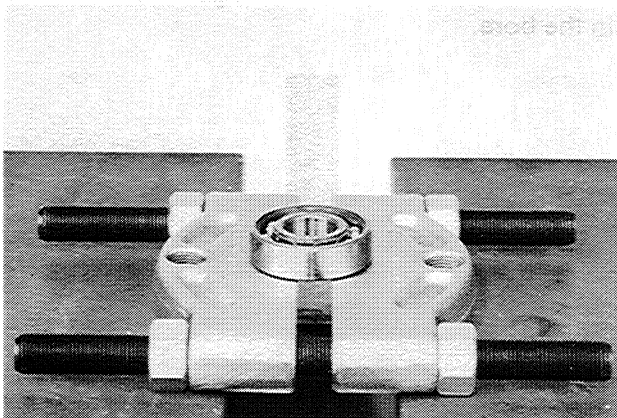

Figure 73

5. Put the pump shaft into the ball bearing so that the snap ring end of the pump shaft is down, as shown in Figure 74.

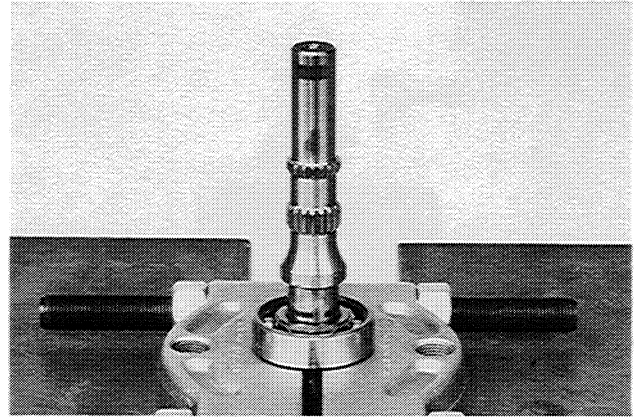

Figure 74

6. Press the pump shaft until the shoulder on the pump shaft makes contact with the inner race of the ball bearing.

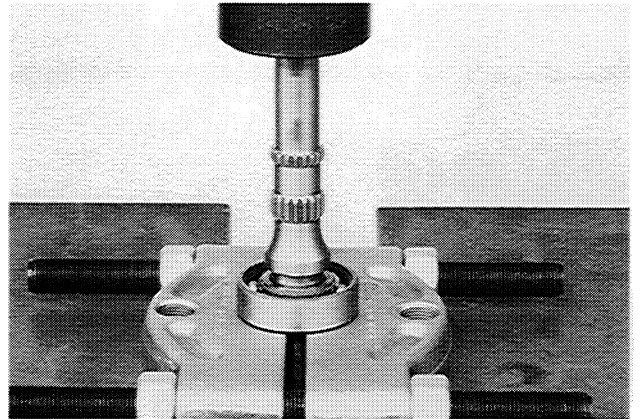

Figure 75

7. Install the snap ring in the groove in the pump shaft.

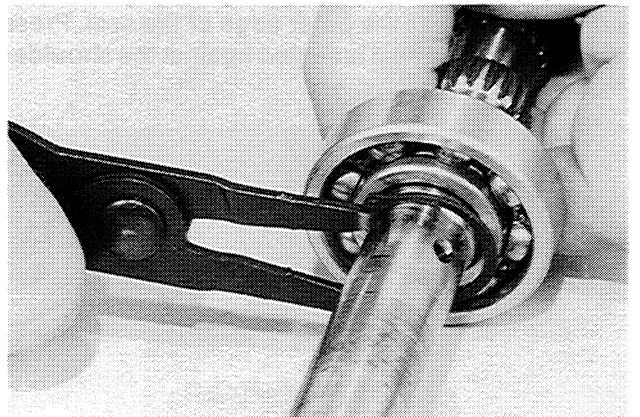

Figure 76

50. Install the springs and the slotted plugs.

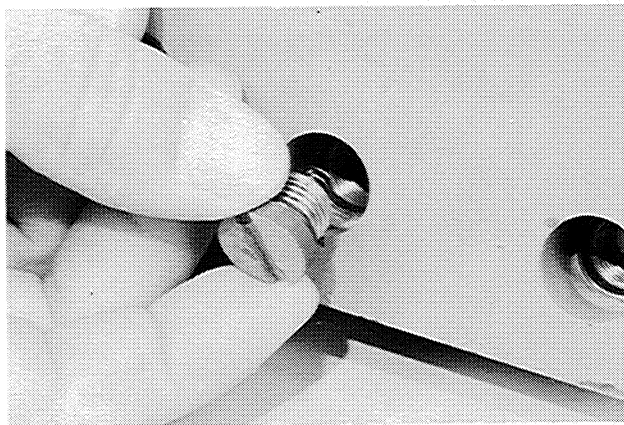

Figure 126

51. See Figure 127. Put the end cap on blocks so that the needle bearing and the pin in the inner face of the end cap are not in contact with the work bench.

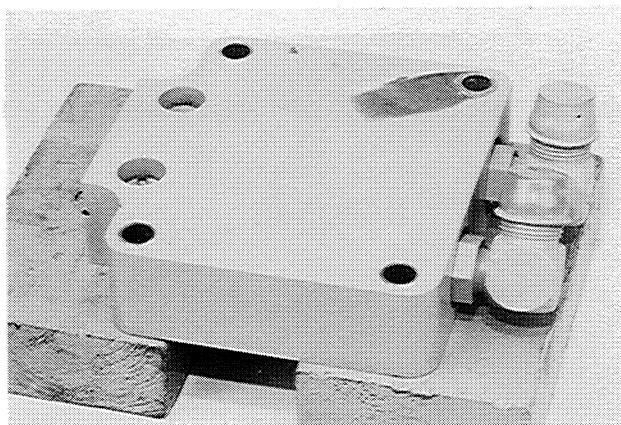

Figure 127

52. Use an acceptable tool, such as an impact driver, to tighten the slotted plugs.



Figure 128

53. Install new O-rings in the two holes in the inner face of the end cap. The two holes are opposite the slotted plugs. Put petroleum jelly on the O-rings to hold the O-rings in position.

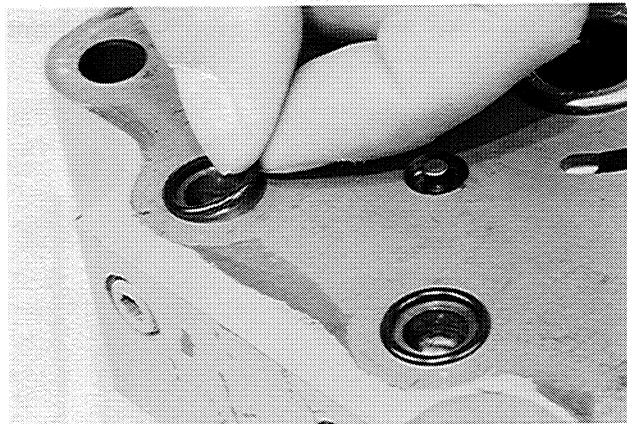

Figure 129

54. Install a new gasket on the housing. Use gasket sealant or petroleum jelly to hold the gasket in position.

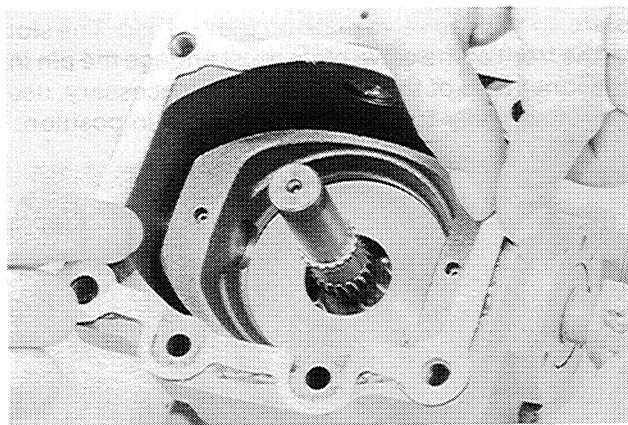

Figure 130

55. Use clean oil to lubricate the pistons. Install the piston guide and the pistons in the piston block.

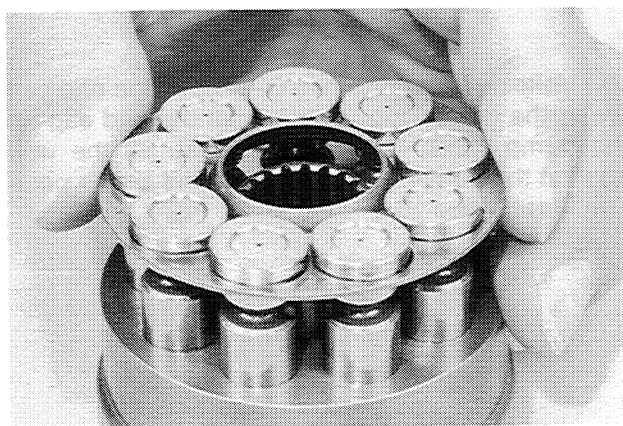

Figure 131

# Section 6007

## HYDROSTATIC MOTOR

Written In *Clear  
And  
Simple  
English*

17. Remove the drive link from the coupling shaft.



Figure 20

18. Remove the thrust bearing from the top of the coupling shaft.



Figure 21

19. Remove the coupling shaft from the housing.



Figure 22

20. Hit the sleeve with a soft hammer to remove the sleeve from the housing.



Figure 23

21. Use an acceptable tool to remove the seal ring from the housing. Discard the seal ring.

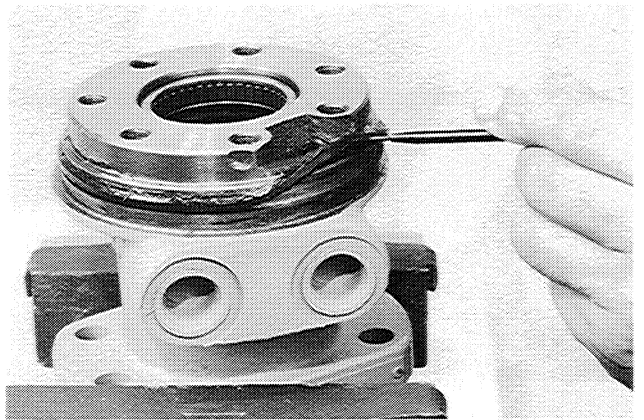

Figure 24

22. Remove the housing from the vise and fasten the housing in the vise again so that the opposite end is up. Use a screwdriver to remove the dirt seal from the end of the housing.



Figure 25

# **Section**

# **6008**

**HYDROSTATIC CONTROLS  
FOR MACHINES WITH  
VICKERS PISTON PUMPS**

# **Section 6010**

**CENTRIFUGAL CLUTCH - 1816**

## OPERATION

When the belt clutch control is in the OFF position, the hydrostatic pumps are pulled inward. When the hydrostatic pumps are pulled inward, the drive belts for the hydrostatic pumps are loosened so that the drive sheave is no longer turning the

driven sheaves for the hydrostatic pumps. Without the load of the hydrostatic pumps, the engine can be started more easily. The equipment hydraulic pump continues to turn any time the drive sheave is turning.

## SHEAVES

### Alignment of Drive Sheave and Driven Sheaves

The grooves on the driven sheaves for the equipment hydraulic pump and the hydrostatic pumps must be aligned with the correct grooves on the drive sheave to within .03 inch (0.8 mm).

### Installation of Split Tapered Bushing on Drive Sheave

Three cap screws are used to fasten the split tapered bushing to the drive sheave. See Figure 8

or 9. If you are installing a split tapered bushing on the drive sheave, use the following procedure to tighten the cap screws:

1. Tighten the three cap screws to a torque of 50 pound-inches (5.6 N m).
2. Tighten the three cap screws to a torque of 100 pound-inches (11.3 N m).
3. Tighten the three cap screws to a torque of 150 pound-inches (16.9 N m).
4. Tighten the three cap screws to a final torque of 180 - 200 pound-inches (20.3 - 22.6 N m).

## DRIVE BELTS

### Clearance for Drive Belts for Hydrostatic Pumps

With the belt clutch control in the Off position, the drive belts for the hydrostatic pumps must be loose enough so that the drive sheave is not turning the hydrostatic pumps. If the drive belts are not loose enough, do the following procedure:

1. Put the belt clutch controls in the OFF position.
2. See Figure 1. Loosen the nuts on the adjusting bolts.
3. Move the adjusting bolts and the wear plates inward until there is clearance between the drive belts and the sheaves.

4. Tighten the nuts on the adjusting bolts to a torque of 20 - 25 pound-feet (27 - 34 N m).

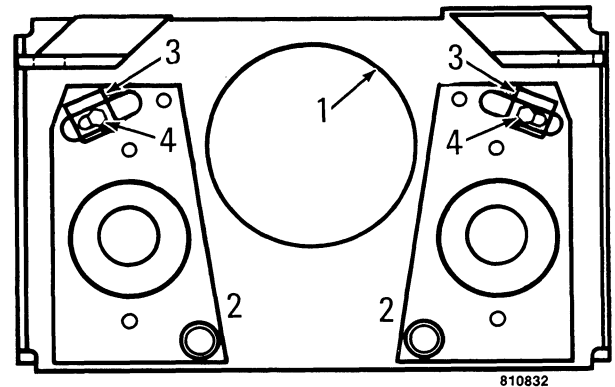

1. Pump and Engine Mounting Plate
2. Mounting Plate for Hydrostatic Pump
3. Wear Plate
4. Adjusting Bolt

Figure 1

## DRIVE CHAINS

### Drive Chain Service

If you are installing a drive chain which has been used before, do the following procedure before you install the drive chain:

1. Use a wire brush to remove all rust and other foreign material from the drive chain.
2. When the drive chain is clean, put the drive chain in 30 weight engine oil for a few minutes.
3. Put the drive chain in a dry place and let any extra oil drain from the drive chain before installing.

### Removal

1. Park the machine on a level surface.
2. Raise the loader frame and use the support strut to fasten the loader frame in place.
3. Stop the engine.
4. Put the belt clutch control (if equipped) in the Off position.
5. Use acceptable lifting equipment to raise the machine until the wheels are off the floor. Put blocks under the machine frame to hold the machine in place.
6. Remove the RH floor plate from the machine.
7. If you are removing the LH front drive chain or one of the rear drive chains, remove the LH floor plate.
8. If you are removing a rear drive chain, do the following procedure:
  - a. Remove the side screen from the side of the machine from which the drive chain is to be removed.
  - b. Remove the seat from the machine.
  - c. Loosen the clamp which fastens the air inlet hose to the tube in the heat shield. Disconnect the air inlet hose from the tube. Put the air inlet hose out of the way.
  - d. Remove the heat shield from the machine.
  - e. Remove the two cap screws, lock washers, and flat washers which fasten the bottom of the instrument panel to the machine frame.
  - f. Remove the cap screw, the lock washer, and the flat washer which fasten the chain compartment cover to the machine frame.
  - g. Slide the chain compartment cover forward to get access to the chain compartment.
9. Remove the wheel nuts and the wheel from the drive axle from which the drive chain is to be removed.
10. Loosen the four flange nuts for the hub.
11. Loosen the lock nut on the chain adjuster.
12. Loosen the chain adjuster.
13. Use a soft hammer to move the hub as far as possible toward the motor sprocket.
14. Find the master link for the drive chain which is to be removed. Remove the two cotter pins from the master link.
15. Remove the side bar from the master link.
16. Remove the master link from the drive chain.

**NOTE:** *If you are removing a rear drive chain, it is recommended that you fasten a piece of wire or cord to the end of the drive chain so that the wire or cord will be carried around the drive axle when the drive chain is removed. The wire or cord can be left in position and used later to install the drive chain.*

17. Remove the drive chain from the machine.

### Installation

1. Install the drive chain on the sprockets. If you are installing a rear drive chain, and you left the wire or cord in place during Removal, use the wire or cord to pull the drive chain into place. When the drive chain is in place, rotate the drive axle to pull the ends of the drive chain together.
2. Install the master link. If you are installing a rear drive chain, install the master link so that the pins are to the outside of the machine. If you are installing a front drive chain, install the master link so that the pins are to the inside of the machine.
3. Install the side bar on the master link.
4. Install new cotter pins in the master link.
5. Use a soft hammer to move the hub to the original location. Tighten the four flange nuts just enough to hold the hub in place.

18. Use a hollow tool which will fit over the drive axle. The hollow tool must have an O.D. approximately the same as the O.D. of the seal. Press the seal into the hub until the top of the seal is even with the edge of the bore.

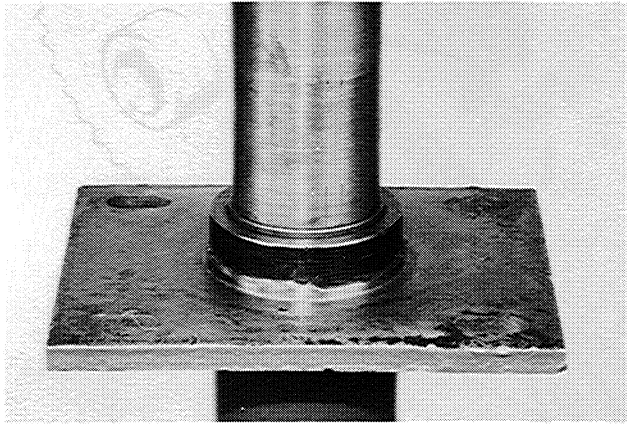

Figure 29

20. Use a hollow tool which will fit over the drive axle. The hollow tool must make contact with the edge of the spacer. Press the spacer into the hub until the spacer makes contact with the bearing cone.

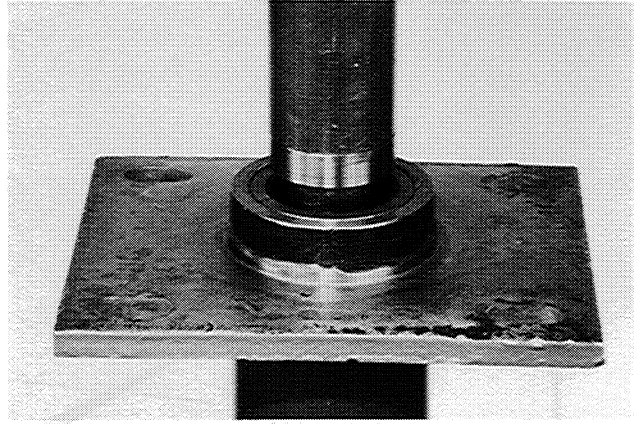

Figure 31

19. Put the spacer over the drive axle so that the beveled edge of the spacer is up.



Figure 30

## Replacement of Wheel Bolts

If a press is available, press the wheel bolts into the flange end of the drive axle until the bolt head is against the flange.

If a press is not available, use a wheel nut and an acceptable spacer to pull the wheel bolts into the flange. The spacer is necessary to pull the bolt heads completely against the flange. Use the flat surface of the wheel nut against the spacer.

## SPECIFICATIONS

<b>Equipment pump output</b> .....	8.0 U.S. gpm at 3600 rpm at 1100 psi (30.3 L/min at 3500 r/min at 7584 kPa)
<b>Main relief valve</b> .....	1100 - 1200 psi at 3600 rpm (7584 - 8274 kPa at 3600 r/min)
<b>Hydraulic oil capacity</b>	
Total system .....	7 U.S. gallons (26.5 litres)
Reservoir with filter change .....	15 U.S. quarts (14.2 litres)
Reservoir without filter change .....	14 U.S. quarts (13.2 litres)
<b>Hydraulic oil</b> .....	SE or SD classification SAE 10W-40 engine oil
<b>Oil change interval</b> .....	Every 1000 hours of operation or once yearly
<b>Filter change interval</b> .....	As required. See page 8002-5

## SPECIAL TOOLS

The tools shown in Figures 1 and 2 are available from Service Tools in the U.S. and from Job-born Manufacturing Co. in Canada. See Special Tools in the Service Manual Introduction for the correct address.

The flowmeter shown in Figure 1 is a 75 U.S. gpm (284 L/min) flowmeter. The flowmeter is used to check for leakage in the hydraulic circuits. The part number is CAS-10280.

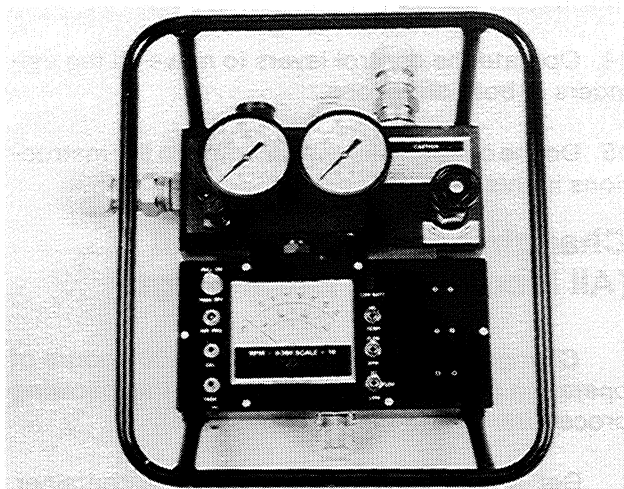

Figure 1

The fitting kit shown in Figure 2 is used to connect the flowmeter into the circuits. The part number of the fitting kit is CAS-10106.



Figure 2

PROBLEM	POSSIBLE CAUSE	CORRECTION
Piston packing wears rapidly	Dirty oil.  Pressure setting for main relief valve is too high.	Clean the complete hydraulic system according to the instructions in Section 8003.  Adjust main relief valve according to the instructions on page 8002-26.
Bent piston rod	Pivot pins are not receiving the correct amount of lubrication.  Pressure setting for main relief valve is too high.	See Section 1002 for correct lubrication intervals and correct grease.  Adjust main relief valve according to the instructions on page 8002-26.

### Hoses and Fittings

PROBLEM	POSSIBLE CAUSE	CORRECTION
Hose cover is separated from the wire	Hose is twisted.	Connect the hose at the swivel fitting last. Make sure that the hose does not turn as the swivel fitting is tightened.
Fitting is pulled from hose or there is a hole in hose	Hose is twisted.  Pressure setting for main relief valve is too high.	Connect hose at the swivel fitting last. Make sure that the hose does not turn as the swivel fitting is tightened.  Adjust main relief valve according to the instructions on page 8002-26.
Damaged threads	Connections too tight.	Tighten all connections to specifications in Section 1001.

5. Increase the engine speed to full throttle. Move the bucket control lever to roll back the grapple.

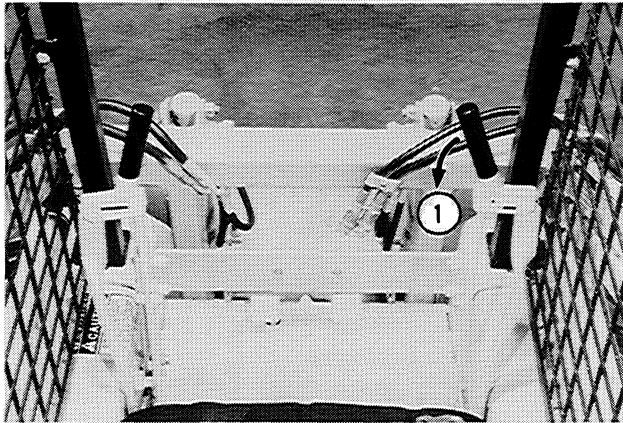

1. Rollback

Figure 41

6. After the grapple stops moving, continue to hold the bucket control lever in the Rollback position.

7. Look at the flow gauge on the flowmeter. Slowly close the pressure valve on the flowmeter. The flow gauge indication will decrease slowly as you close the pressure valve.

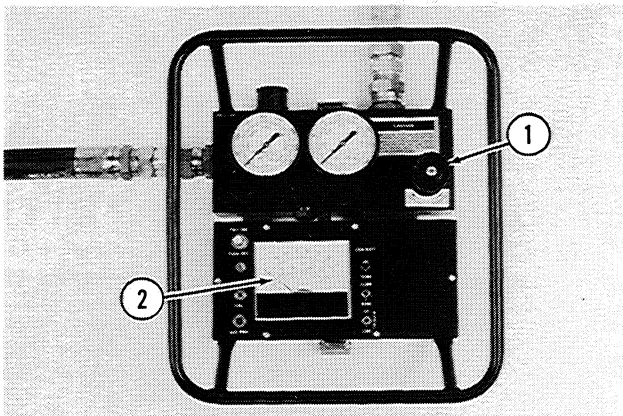

1. Pressure Valve  
2. Flow Gauge

Figure 42

8. When the main relief valve starts to open, the flow gauge will indicate a rapid decrease in volume. Stop turning the pressure valve, read the indication on the pressure gauge, and write the indication on the check sheet. This pressure is the pressure at which the main relief valve begins to open.

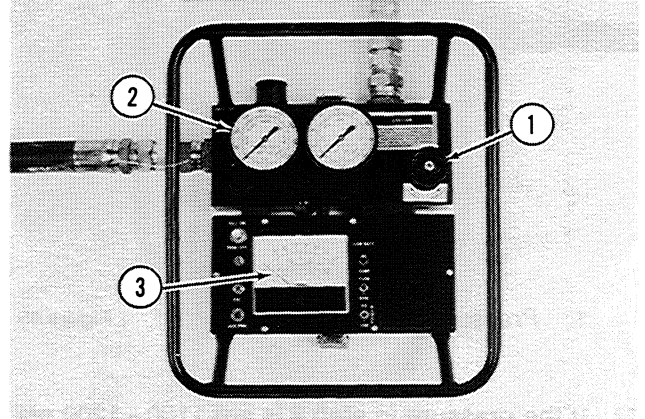

1. Pressure Valve  
2. Pressure Gauge  
3. Flow Gauge

Figure 43

9. Continue to close the pressure valve on the flowmeter. When the indication on the flow gauge is zero or very nearly zero, read the indication on the pressure gauge and write this indication on the check sheet. This pressure is the pressure at which the main relief valve is completely open.

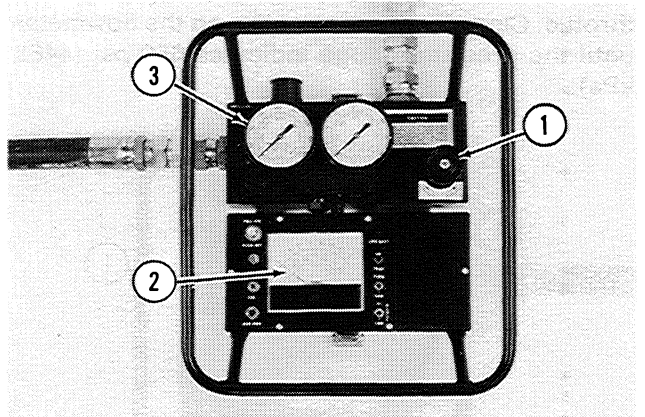

1. Pressure Valve  
2. Flow Gauge  
3. Pressure Gauge

Figure 44

11. Use the fitting kit shown in Figure 2 to connect the valve to both drain plug holes. Make sure that the valve is closed.

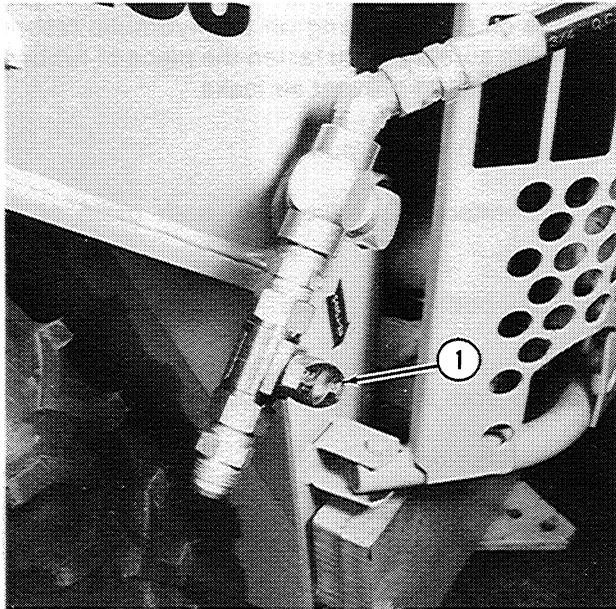

1. Valve Closed

Figure 5

12. Stop the vacuum pump.

13. Connect the inlet hose for the portable filter to the valve that is connected to the drain plug holes.

14. Remove the clamp and piece of rubber from the oil filler opening.

15. See the fitting kit shown in Figure 2. Connect the outlet hose for the portable filter to the long tube in the fitting kit. Put the long tube in the hydraulic reservoir.

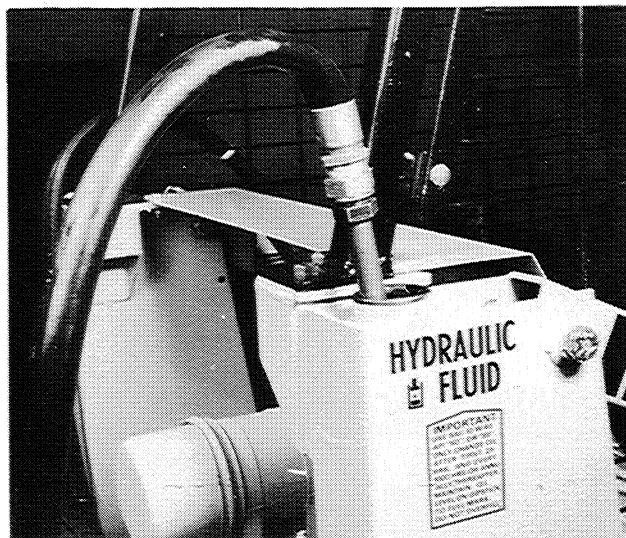
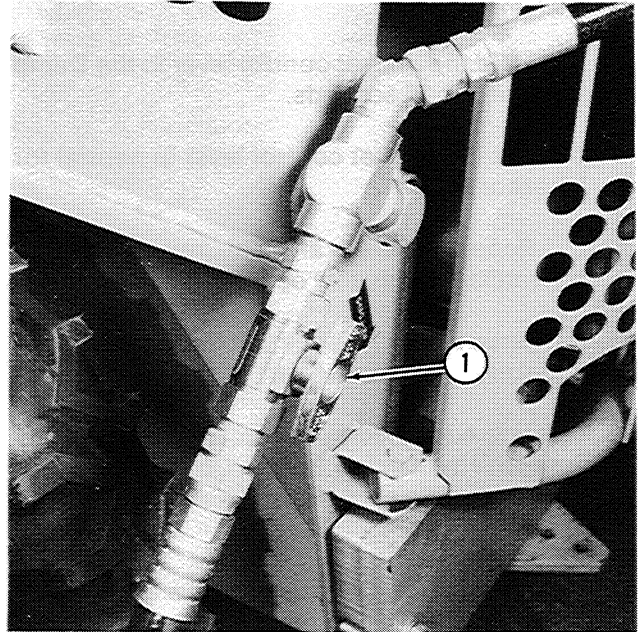

Figure 6

16. Open the valve that is connected to the drain plug holes.



1. Valve Open

Figure 7

17. Put the switch for the portable filter in the On position. Start and run the engine at half throttle.

18. Run the portable filter for 10 minutes. During this 10 minute period, use the long tube on the outlet hose to mix the oil in the hydraulic reservoir.

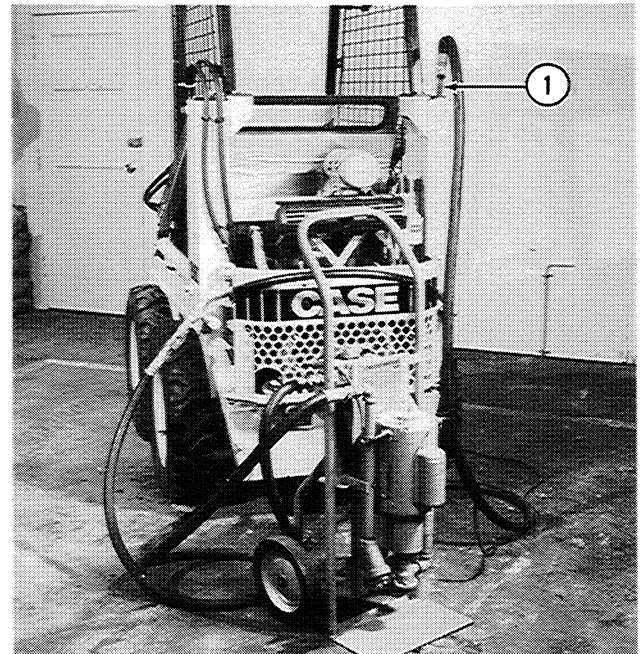

1. Long Tube

Figure 8

19. Continue to run the portable filter.

5. Remove the O-ring from the body.

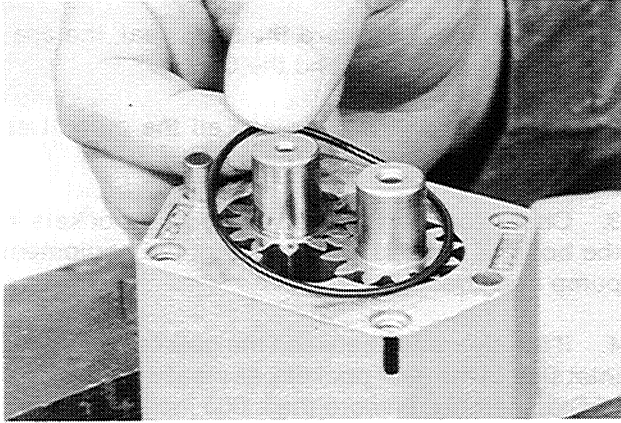

Figure 9

8. Remove the drive gear from the body.

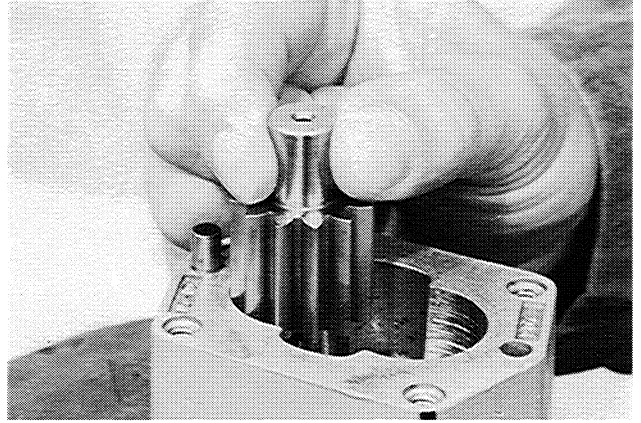

Figure 12

6. See Figure 10. Use a feeler gauge to measure the clearance between the gear teeth and the inlet side of the gear pockets. If the clearance is more than .005 inch (0.13 mm), the equipment pump must be replaced.

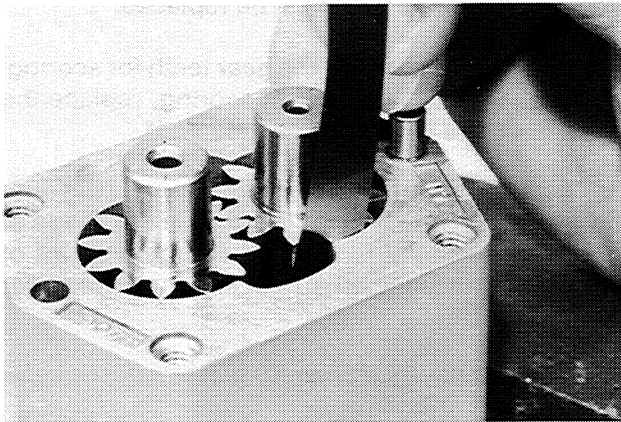

Figure 10

9. Remove the wear plate, the pressure seal, and the spacer from the body as an assembly.

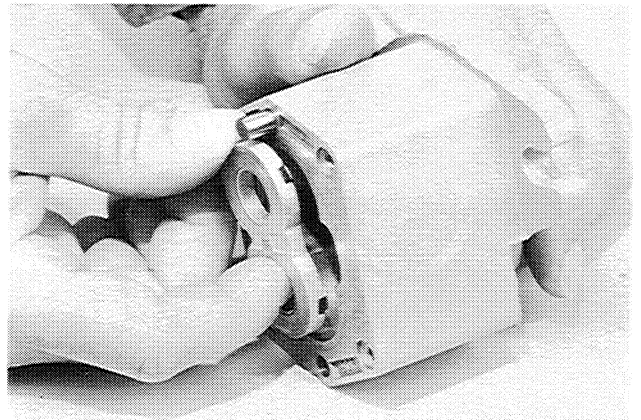

Figure 13

7. Remove the driven gear from the body.

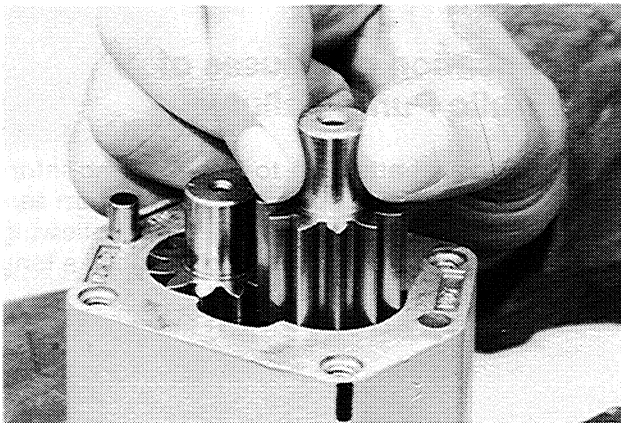

Figure 11

10. Remove the spacer, if equipped, from the wear plate.



Figure 14

## OPERATION

### Oil Flow, Lift Spool Actuated

See Figure 2. The lift spool is moved into the equipment control valve. The following conditions occur:

- The open center passage is closed.
- With the open center passage closed, oil from the equipment pump flows to the A port of the lift spool. From the A port, oil flows to the rod ends of the lift cylinders, causing the loader frame to lower.
- At the same time, the B port of the lift spool is open to the return passage. Oil which is pushed from the closed ends of the lift cylinders returns to the hydraulic reservoir.

When the lift spool is returned to the Neutral position, oil is held between the equipment control valve and the lift cylinders, preventing movement of the loader frame.

To raise the loader frame, the lift spool is moved out of the equipment control valve, and the oil flow is the reverse of the description given above.

### Main Relief Valve

The main relief valve is at the inlet of the equipment control valve. The passage in the poppet seat connects the main relief valve to the open center passage.

When the cylinders are extended to the end of their travel or are prevented from moving for any reason when the spool is in a power position, the main relief valve opens to protect the hydraulic system from damage. When the main relief valve is open, oil from the equipment pump flows to the hydraulic reservoir.

- See Figure 2. In this example the loader frame is completely lowered, and the spool is held in the power position.
- With the open center passage closed and the cylinders prevented from moving, pressure in the open center passage increases immediately to the setting of the main relief valve.

- This pressure in the open center passage pushes the poppet off the poppet seat.
- Oil from the equipment pump then flows through the return passage and back to the hydraulic reservoir.
- The main relief valve stays open until the spool is returned to the Neutral position.

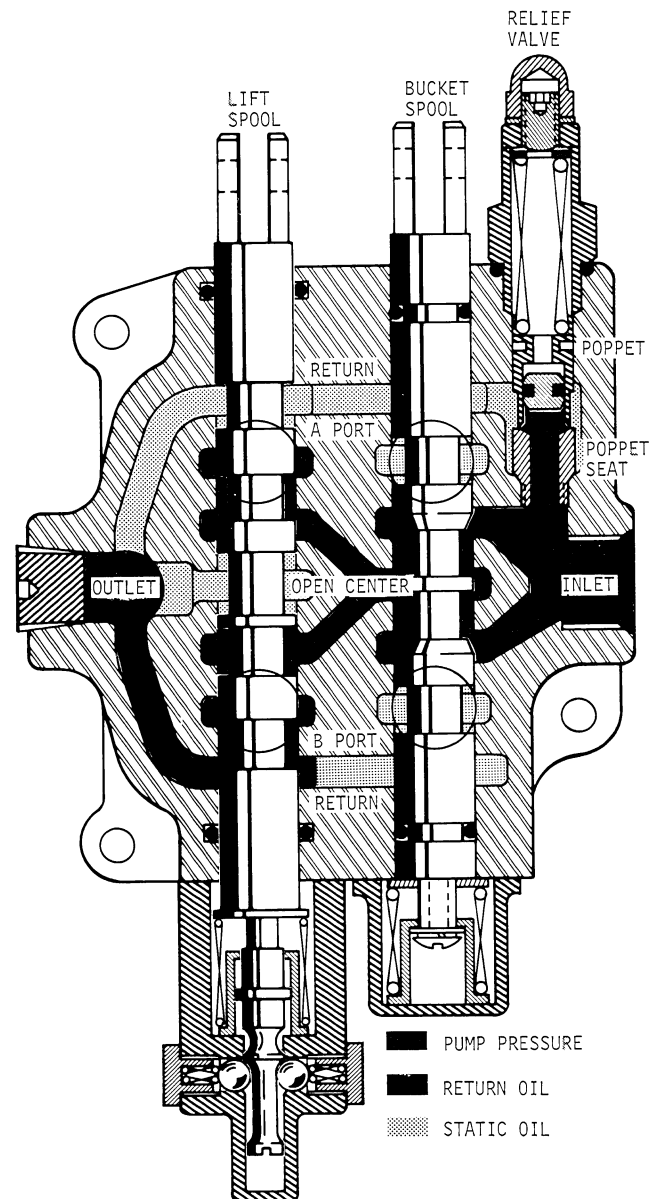

811461

Figure 2 - Oil Flow, Lift Spool Actuated

32. Put the body of the equipment control valve in the vise so that the bore for the relief valve is up.

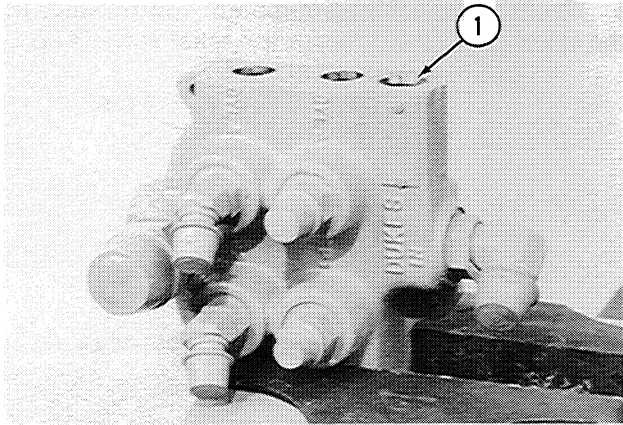

1. Bore for Relief Valve

Figure 33

33. The poppet seat is installed with Loctite and can be difficult to remove. Use an Allen wrench to remove the poppet seat from the body.

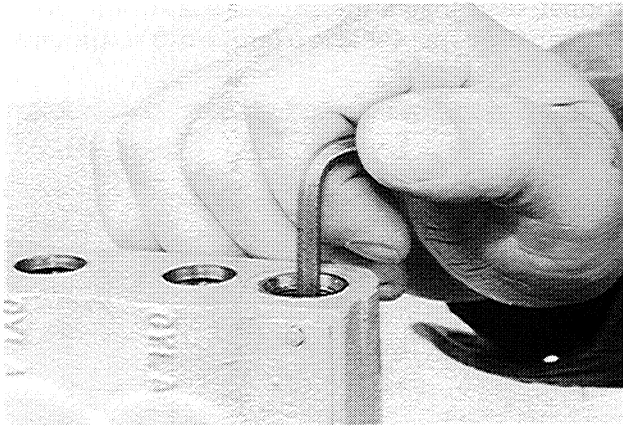

Figure 34

34. Remove and discard the O-ring from the relief valve head.

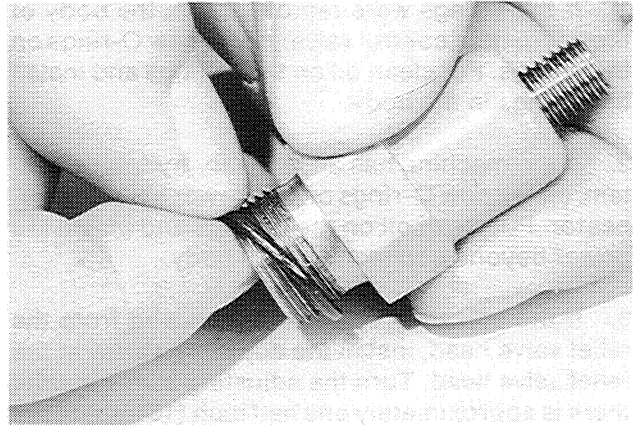

Figure 35

35. It is not necessary to remove the adjusting screw from the relief valve head unless there is an indication of damage to either the adjusting screw or the relief valve head.

36. If the machine has an auxiliary hydraulic system, remove the power beyond connector from the body. Remove and discard the O-rings from the power beyond connector.

37. Do not remove the remainder of the fittings from the body unless there is an indication that the fittings or the O-rings are damaged.

## INSPECTION

1. Discard all O-rings.
2. Clean all parts in cleaning solvent.
3. Check the spools and spool bores for damage and wear. If a spool has damage or wear, the complete equipment control valve must be replaced.
4. Inspect the poppet and the poppet seat for defects that can cause leakage. Replace parts as necessary.
5. Check all springs for distortion or other damage. If it is possible, compare the spring tension of the old springs with the spring tension of a new spring. Replace any springs which have defects.

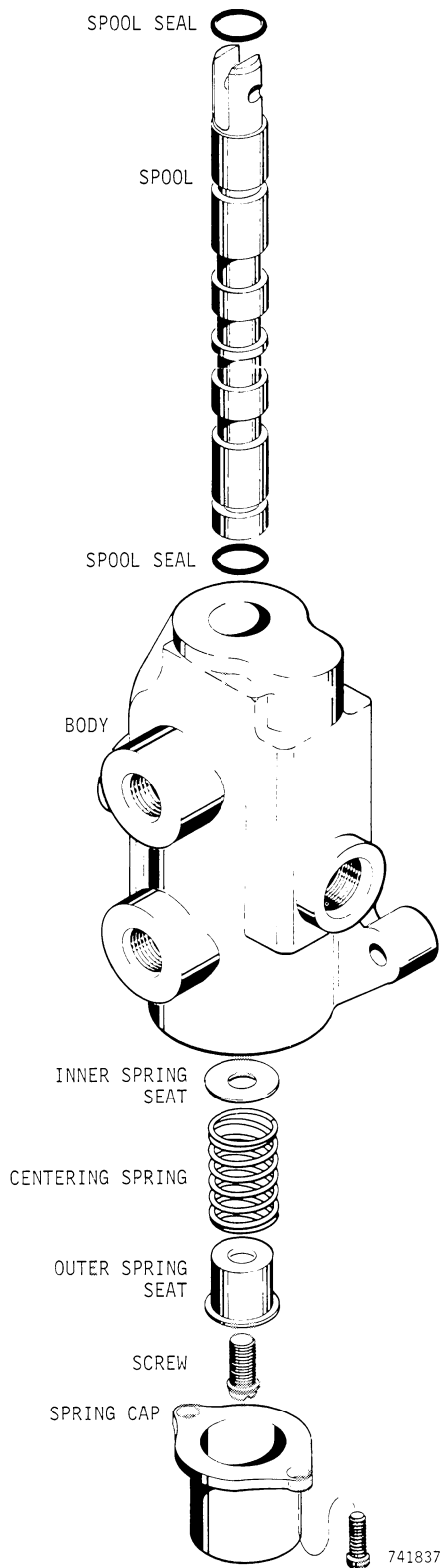

## Assembly

1. Install new spool seal in groove at eye end of the spool. Lubricate spool and spool bore with clean hydraulic oil.
2. Install spool, spring end first, in top of spool bore. Push spool into valve until seal groove at bottom of spool is exposed. Then install seal in groove.
3. Push spool into valve from spring end until large O.D. is flush with valve body. Place inner spring seat on spool. Then install centering spring and outer spring seat and secure in place with screw. Make sure screw is tight.
4. Position spring cap on valve body and secure in place with screws.

## Installation

1. Place control valve on mounting bolts and secure in place with lock washers and nuts.
2. Connect pedal linkage to valve spool.
3. Connect hoses to control valve. Refer to exploded view in Section 9001 for proper connections if hoses and connecting points were not identified as instructed.
4. Install floor plate. Fill hydraulic reservoir to the proper level with oil specified in Section 1002.
5. Start engine and actuate auxiliary cylinder through several cycles to bleed air from the system. Stop engine and check for leaks. Check reservoir oil level and add oil as required.

Figure 1 - Auxiliary Control Valve

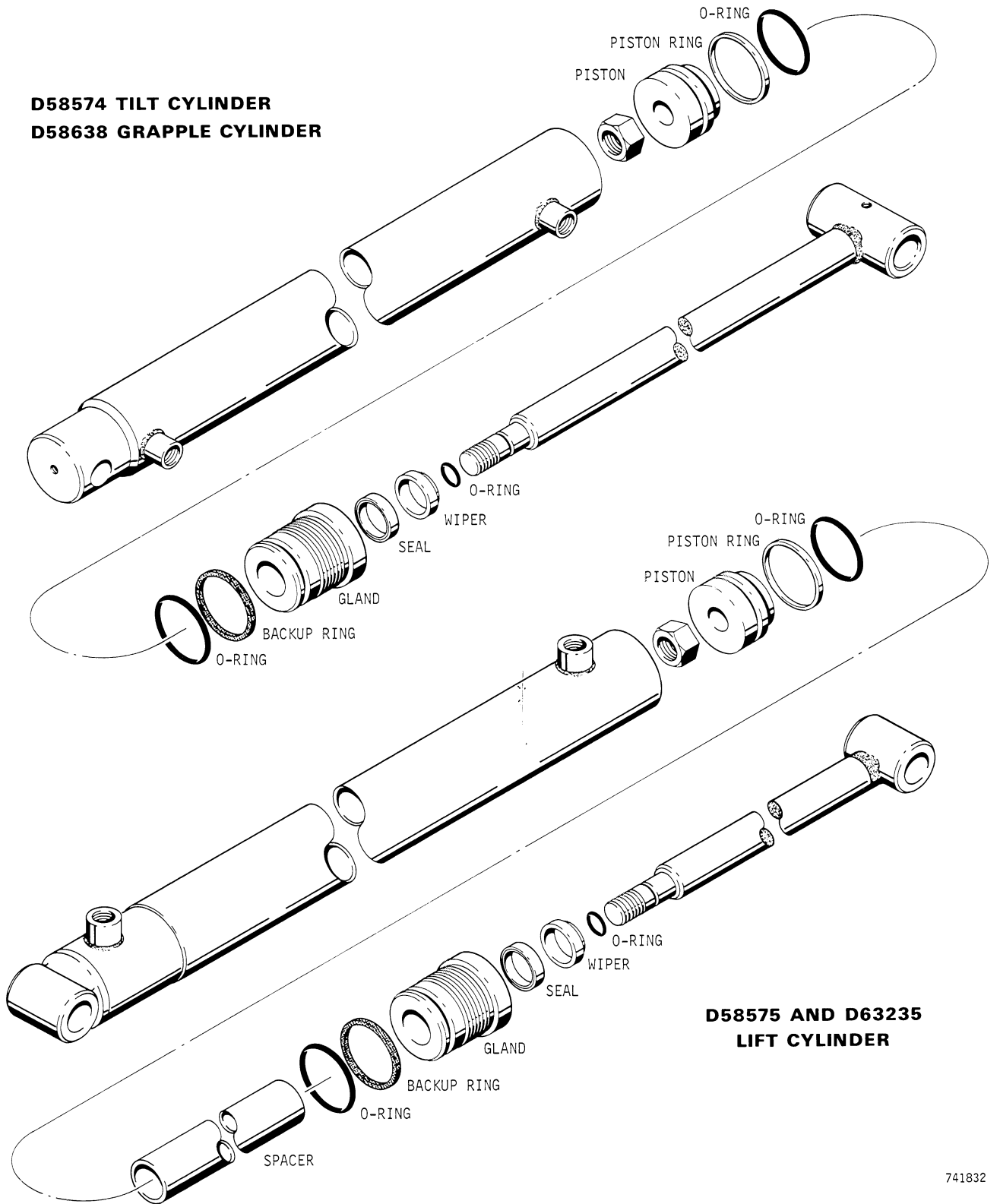
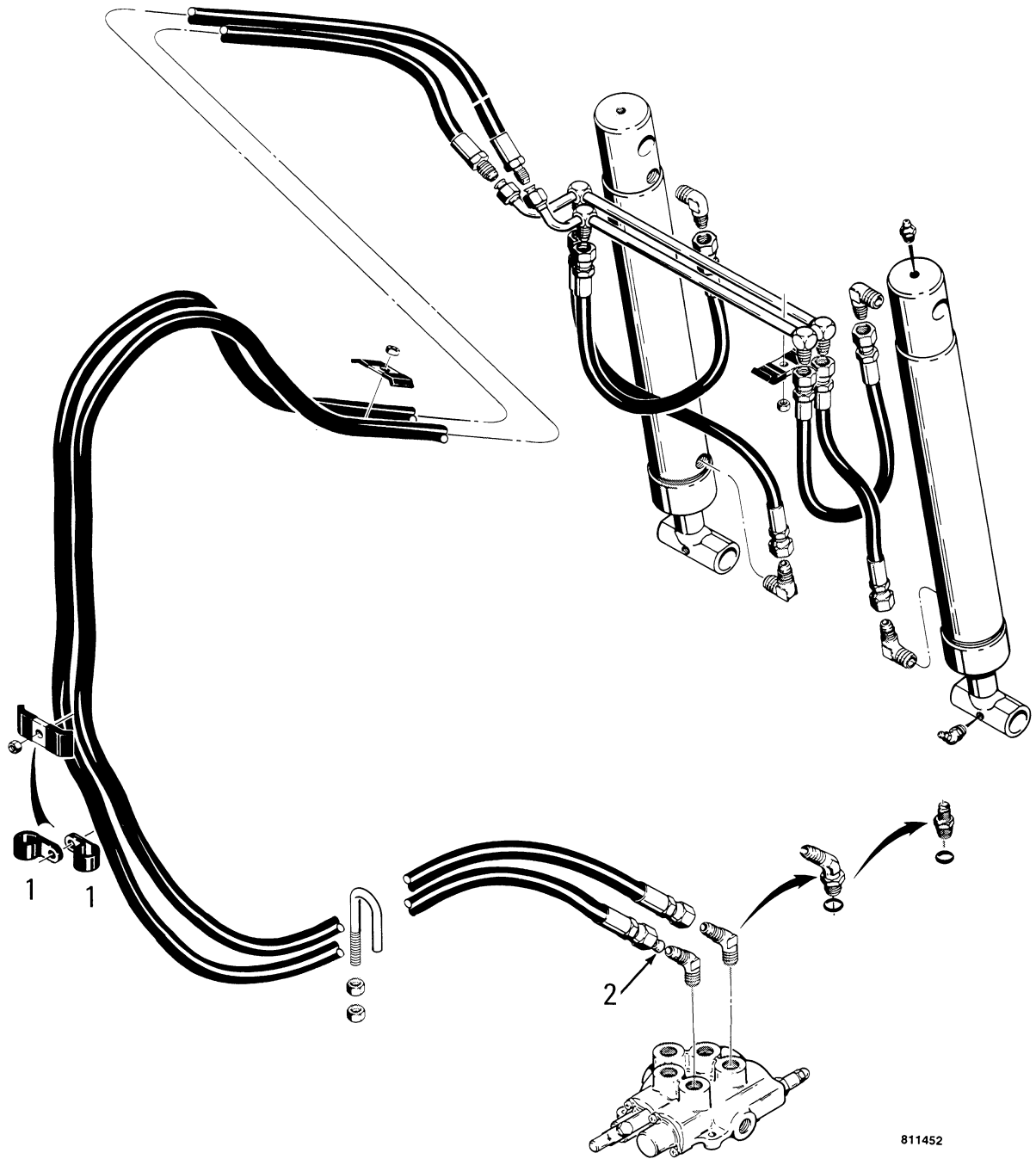

Figure 4 - D58575 and D63235 Lift Cylinder, D58574 Tilt Cylinder and D58638 Grapple Cylinder



811452

- 1. Clamp (Late Production)
- 2. Restrictor (Must Be Installed Here)

Figure 14 - Bucket Cylinder Hydraulic Installation

# Section 9002

## PALLET FORK, MANURE FORK, AND GRAPPLE

Written In *Clear  
And  
Simple  
English*

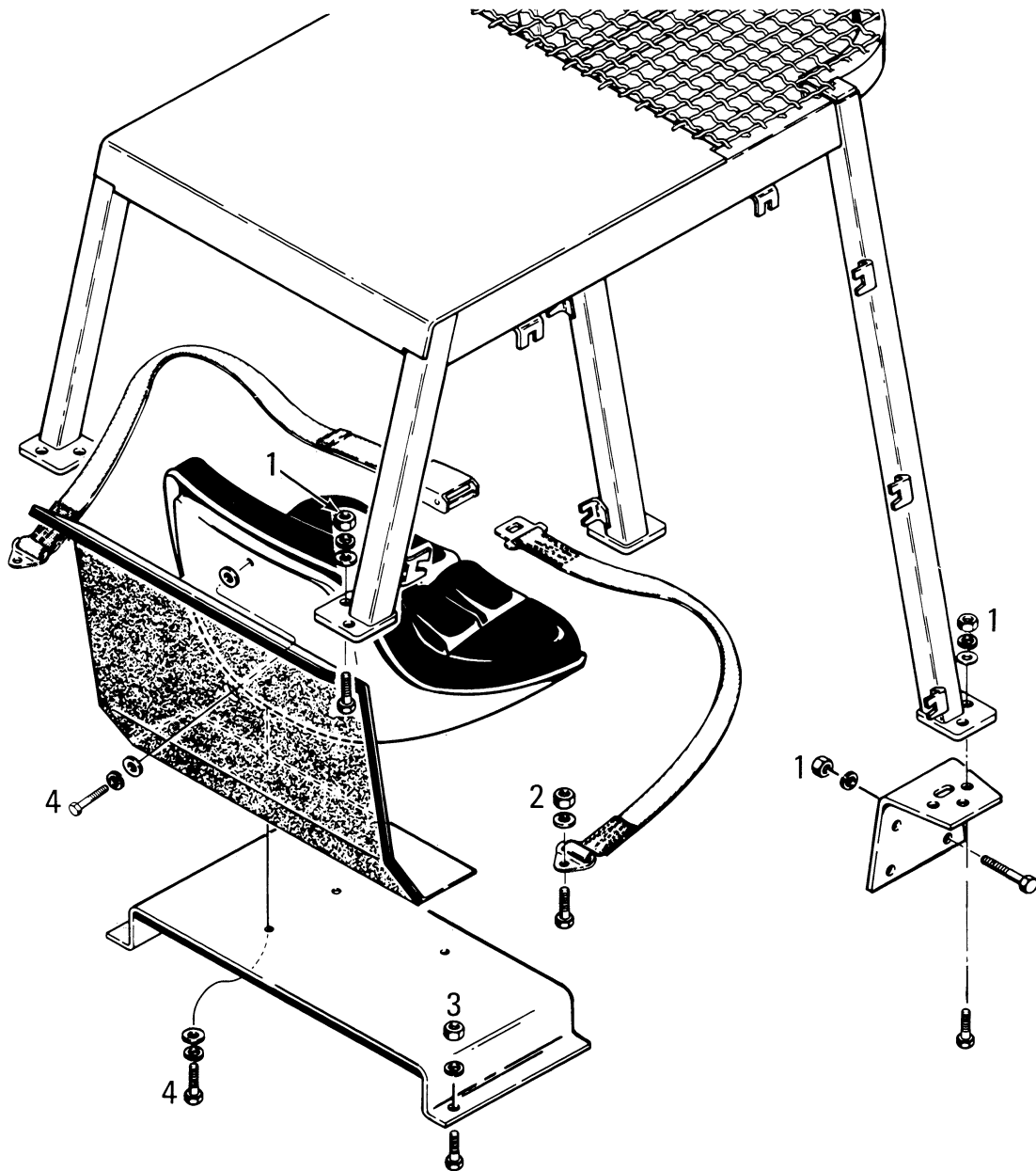

1. Tighten to a Torque of 53 - 60 Pound-Feet (72 - 81 N m)
2. Tighten to a Torque of 45 - 55 Pound-Feet (61 - 75 N m)

3. Tighten to a Torque of 16 - 24 Pound-Feet (22 - 33 N m)
4. Tighten to a Torque of 25 - 35 Pound-Feet (34 - 47 N m)

810831

Figure 2 - ROPS and Seat Installation - Late Production

CLICK HERE TO **DOWNLOAD** THE COMPLETE MANUAL

- Thank you very much for reading the preview of the manual.
- You can download the complete manual from: [www.heydownloads.com](http://www.heydownloads.com) by clicking the link below



- Please note: If there is no response to CLICKING the link, please download this PDF first and then click on it.

CLICK HERE TO **DOWNLOAD** THE COMPLETE MANUAL