

550E Crawler
Service Manual

Table of Contents

| Description | Section No. | Form No. |
|---|--------------|----------|
| General | Tab 1 | |
| Section Index - General | | 8-13600 |
| Standard Torque Specifications | 1001 | 8-71601 |
| Fluids and Lubricants | 1002 | 7-44000 |
| Loctite Product Chart | | 8-98900 |
| Engine | Tab 2 | |
| Section Index - Engine | | 8-14440 |
| Engine Stall Tests | 2000 | 7-44010 |
| Engine Removal and Installation and Radiator Removal and Installation | 2001 | 7-44040 |
| Specification Details | 2402 | 8-24163 |
| Cylinder Head and Valve Train | 2415 | 8-24173 |
| Cylinder Block | 2425 | 8-24183 |
| Lubrication System | 2445 | 8-24193 |
| Cooling System | 2455 | 8-24203 |
| Turbocharger | 2465 | 8-25550 |
| Turbocharger Failure Analysis | 2565 | 9-78235 |
| Fuel System | Tab 3 | |
| Section Index - Fuel System | | 8-18990 |
| Fuel System and Filters | 3410 | 8-24212 |
| Fuel Injectors | 3413 | 8-24233 |
| CAV Injection Pump (4-390) | 3414 | 7-37131 |
| Bosch Injection Pump (4T-390) | 3415 | 7-37141 |
| Electrical | Tab 4 | |
| Section Index - Electrical | | 8-19000 |
| Removal and Installation of Electrical Components | 4001 | 8-13650 |
| Electrical Specifications, Troubleshooting and Schematic | 4002 | 8-19010 |
| Batteries | 4003 | 8-11361 |
| Instrument Panel and Gauges | 4004 | 7-44050 |
| Starter and Starter Solenoid 4006 | | 8-72280 |
| Alternator | 4007 | 8-15670 |
| Track | Tab 5 | |
| Section Index - Track | | 8-14520 |
| Uundercarriage Fundamentals | 5001 | 8-99830 |
| Inspection of Track System Components | 5501 | 7-44140 |
| Case Lubricated Track | 5504 | 8-99720 |
| Sealed Track and Track Frame | 5506 | 8-13703 |
| RubberTrack | 5507 | 7-44060 |
| Idler, Track Adjuster and Recoil Housing | 5508 | 8-13710 |
| Sprocket | 5509 | 7-44070 |
| Carrier Roller | 5510 | 8-13730 |
| Track Roller | 5511 | 8-13740 |

Reprinted

CLICK HERE TO **DOWNLOAD** THE COMPLETE MANUAL

- Thank you very much for reading the preview of the manual.
- You can download the complete manual from: www.heydownloads.com by clicking the link below



- Please note: If there is no response to CLICKING the link, please download this PDF first and then click on it.

CLICK HERE TO **DOWNLOAD** THE COMPLETE MANUAL

CAPACITIES AND LUBRICANTS

Engine Oil

Capacity with Filter Change 11 U.S. quarts (10.4 litres)

Type of oil..... See Engine Oil Recommendations on page 3.

Engine Cooling System

Capacity..... 16.5 U.S. quarts (15.6 litres)

Type of coolant..... Ethylene glycol and water mixed for lowest ambient temperature
At least 50/50 mixture

Fuel Tank

Capacity..... 30.5 U.S. gallons (115.5 litres)

Type of fuel..... No. 1 Diesel fuel

Hydraulic System

Hydraulic reservoir refill capacity 10.3 U.S. gallons (39 litres)

Type of oil..... Case TCH Fluid

Transmission

Capacity..... 8 U.S. gallons (30.3 litres)

Type of oil..... Case TCH Fluid

Final Drives

Refill capacity (each side) 6 U.S. quarts (5.7 litres)

Type of oil..... Case IH 135-H EP gear lube

PROCEDURE TO HEAT THE OIL

Torque Converter

1. Do the following steps to check the brakes:
 - a. Apply the center brake pedal.
 - b. Put the range control lever in LO.
 - c. Start and run the engine at low idle.
 - d. Put the track speed control levers in HI.
 - e. Put the direction control lever in F.
 - f. Slowly increase the engine speed to full throttle. If the brakes do not keep the machine from moving, stop the engine.
 - g. See Section 9000 and adjust the brakes.
 - h. Repeat steps 1a through 1g until the center brake pedal keeps the machine from moving with the engine running at full throttle.
2. Run the engine at low idle. Apply the center brake pedal.
3. Put the range control lever in HI.
4. Put both track speed control levers in HI.
5. Put the direction control lever in F.

6. Run the engine at full throttle with the direction control lever in F for two minutes. Then reduce engine speed to low idle and put the direction control lever in NEUTRAL.

7. Run the engine at full throttle with the direction control lever in NEUTRAL for one minute. Then reduce engine speed to low idle and put the direction control lever in F.

8. Repeat steps 6 and 7 until the needle in the temperature gauge is in the green zone.

Hydraulic System

1. Put the transmission control levers in NEUTRAL.
2. Start and run the engine at full throttle.
3. Put the blade control lever in TILT position.
4. Hold the blade control lever in the TILT position for 15 seconds. Then put the blade control lever in NEUTRAL for 30 seconds.
5. Repeat steps 3 and 4 until the temperature of the hydraulic oil is between 125 and 175°F (52 to 79°C). If a thermometer is not available, feel the tube connected to the inlet of the equipment control valve. The tube must be very warm.

STEP 27

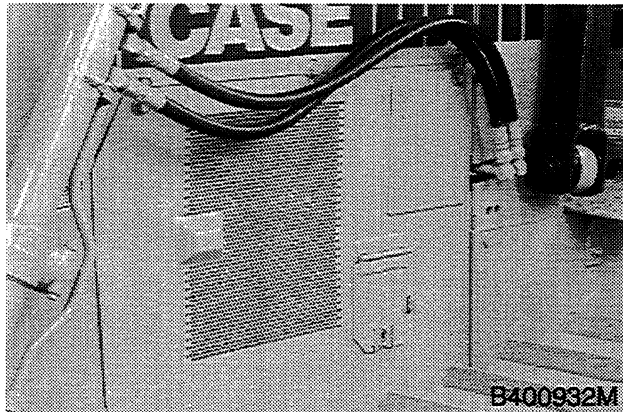

Remove the engine side panels.

STEP 28



Remove the precleaner or cap from the air cleaner tube.

STEP 29



Remove the rubber seal from the air cleaner tube.

STEP 30

If the machine has brush guards, remove the brush guards.

STEP 31

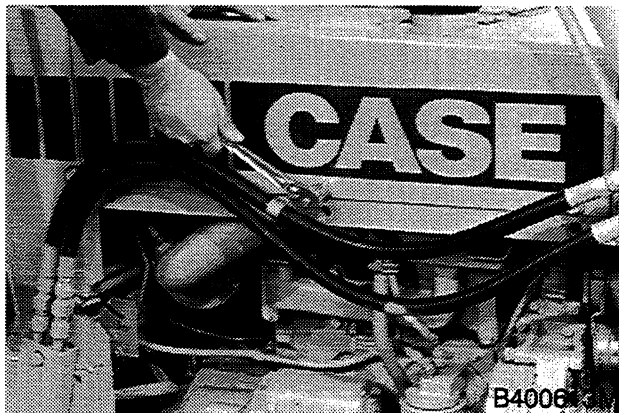

Remove the cap screws, bolts, and nuts that fasten the hood in place.

STEP 32



Remove the hood.

STEP 33

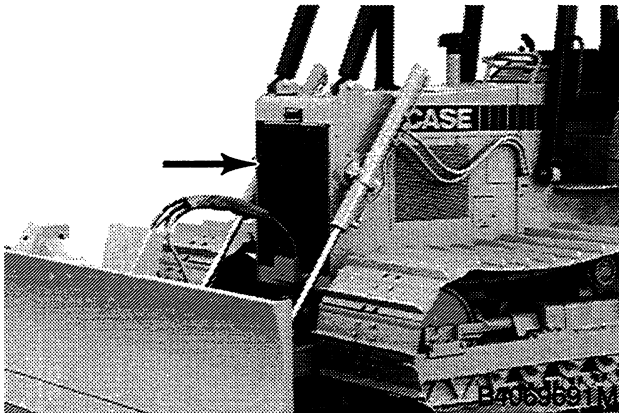

Remove the grille.

11. Loosen completely the nut that holds the temperature sensor in the tee at the bottom of the torque converter housing.

12. Remove the temperature sensor and put the temperature sensor out of the way.

13. Remove the cap screws that hold the floor plate. Remove the floor plate from the machine.

14. Remove the cap screws that hold the torque converter housing.

15. Have another person help with the removal of the torque converter housing.

16. Move the torque converter housing to the rear until the output shaft is free of the torque converter.

17. Carefully lower the torque converter housing to the floor and remove the torque converter housing from under the machine.

18. Remove the cap screws that hold the torque converter. Remove the torque converter from the housing.

Piston Rings

| | |
|---------------------------------|--------------------------------|
| No. 1 Compression 4T-390 Engine | Key Stone Type (Barrel Face) |
| End Gap in 102.02 ID | 0.4 to 0.70 mm |
| No. 1 Compression 4-390 Engine | Rectangular Type (Barrel Face) |
| End Gap in 102.02 ID | 0.25 to 0.55 mm |
| Maximum Service Limit | 0.806 mm |
| Side Clearance | 0.075 to 0.120 mm |
| Maximum Service Limit | 0.15 mm |
| No. 2 Compression | Rectangular Type (Tapper Face) |
| End Gap in 102.02 ID | 0.25 to 0.55 mm |
| Maximum Service Limit | 0.806 mm |
| Side Clearance | 0.075 to 0.120 mm |
| Maximum Service Limit | 0.15 mm |
| No. 3 Oil Control Rings | Two Piece |
| End Gap in 102.02 ID | 0.25 to 0.55 mm |
| Maximum Service Limit | 0.806 mm |
| Side Clearance | 0.130 mm |

Cylinder Head

| | |
|---|----------------------|
| Warpage (Maximum) | 0.20 mm |
| Maximum Material Removal | 1.00 mm |
| Minimum Head Height | 93.75 mm |
| Engines Manufactured in U.S.A.: | |
| Prior to Engine Serial Number 45511034 | Injector Nozzle 9 mm |
| Engine Serial Number 45511034 and After | Injector Nozzle 7 mm |
| Engines Manufactured in Darlington England: | |
| Prior to Engine Serial Number 21092870 | Injector Nozzle 9 mm |
| Engine Serial Number 21092870 and After | Injector Nozzle 7 mm |
| Engines Manufactured in Neuss Germany: | |
| Prior to Engine Serial Number 52107489 | Injector Nozzle 9 mm |
| Engine Serial Number 52107489 and After | Injector Nozzle 7 mm |

Lifters

| | |
|------------------------|---------------------|
| Material | Hardened Iron |
| OD of Lifter | 15.961 to 15.977 mm |
| Minimum Service Limit | 15.960 mm |
| Bore Diameter in Block | 16.000 to 16.030 mm |
| Maximum Service Limit | 16.055 mm |

TABLE OF CONTENTS

| | |
|--|-------|
| IDENTIFICATION MARKS | 2 |
| SPECIFICATIONS..... | 3 |
| SPECIAL TORQUES..... | 4 |
| SPECIAL TOOLS | 5 |
| CYLINDER HEAD REMOVAL | 6-10 |
| CYLINDER HEAD DISASSEMBLY..... | 11 |
| CHECKING AND RESURFACING THE CYLINDER HEAD | 12,13 |
| VALVE GUIDE REPLACEMENT | |
| 14 mm Replacement Valve Guides | 14 |
| 11 mm Replacement Valve Guides | 15 |
| INSPECTION OF THE VALVES AND VALVE SEATS..... | 16-18 |
| VALVE SEAT INSTALLATION | 19 |
| REFACING INTAKE AND EXHAUST VALVES AND VALVE SEATS | 20-26 |
| CYLINDER HEAD ASSEMBLY | 27,28 |
| ROCKER ARM DISASSEMBLY | 28,29 |
| ROCKER ARM ASSEMBLY..... | 29 |
| CYLINDER HEAD INSTALLATION | 30-34 |
| LOCATING TOP CENTER..... | 35 |
| ADJUSTING THE ROCKER ARM TO VALVE CLEARANCE..... | 35-39 |
| THERMOSTAT SERVICE..... | 39-40 |

IDENTIFICATION MARKS

Letter G = Thermostat passage in cylinder did not need to be machined.

Letter M = Thermostat passage in cylinder head was machined.

Letter V = Valve seats have been machined.

Letter X = The cylinders in the cylinder block have been bored oversize. Use a head gasket with oversize cylinder holes (one notch).

Letter XX = The cylinder block has been refaced and up to 0.25 mm has been removed. Use a thicker head gasket (two notches).

Letter XXX = The cylinder block has been refaced and up to 0.50 mm has been removed. Use a thicker head gasket (three notches).

Numbers = RH rear corner of cylinder head indicates the amount of material removed from the cylinder head.

CHECKING AND RESURFACING THE CYLINDER HEAD

STEP 36

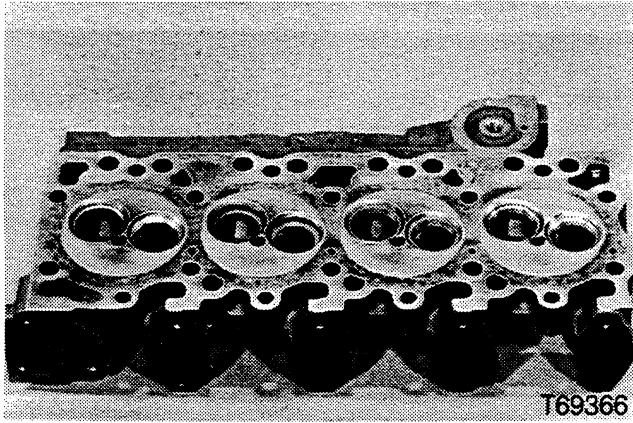

Clean the cylinder head completely. Remove carbon and other deposits. Check for cracks and any other damage to the head.

STEP 37

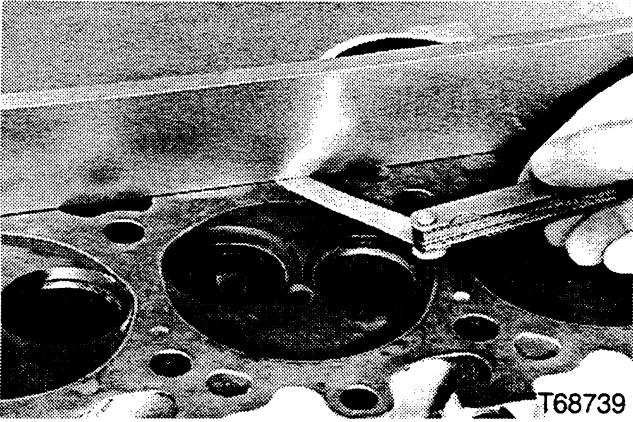

Check the cylinder head surface with a straight edge and feeler gauge. Resurface the cylinder head if warpage or erosion is more than 0.010 mm in any 50 mm diameter area or if there is more than 0.075 mm overall end to end or side to side.

STEP 38

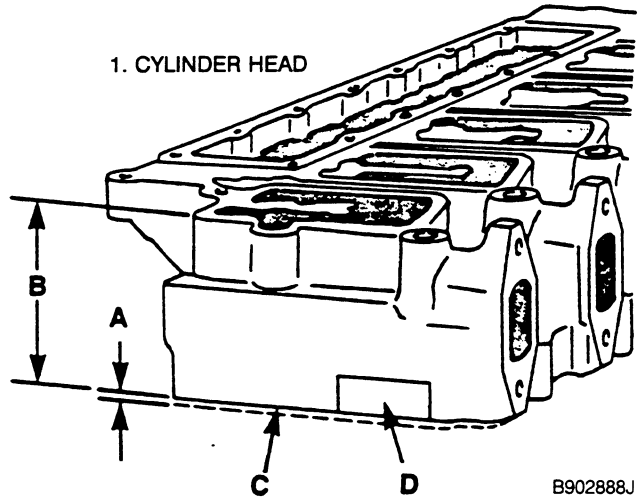

Resurface the cylinder head in increments necessary to straighten the surface and maintain surface finish according to the following specifications:

A = 1.0 mm total amount of material removed.

B = 93.75 mm minimum total height of the cylinder head.

C = Surface finish 1.5 to 3.2 micrometers.

D = Use this area to stamp the total thickness of cylinder head material removed in mm.

DIAGNOSIS OF DIFFERENT DYE PATTERNS 45 Degree Exhaust valves

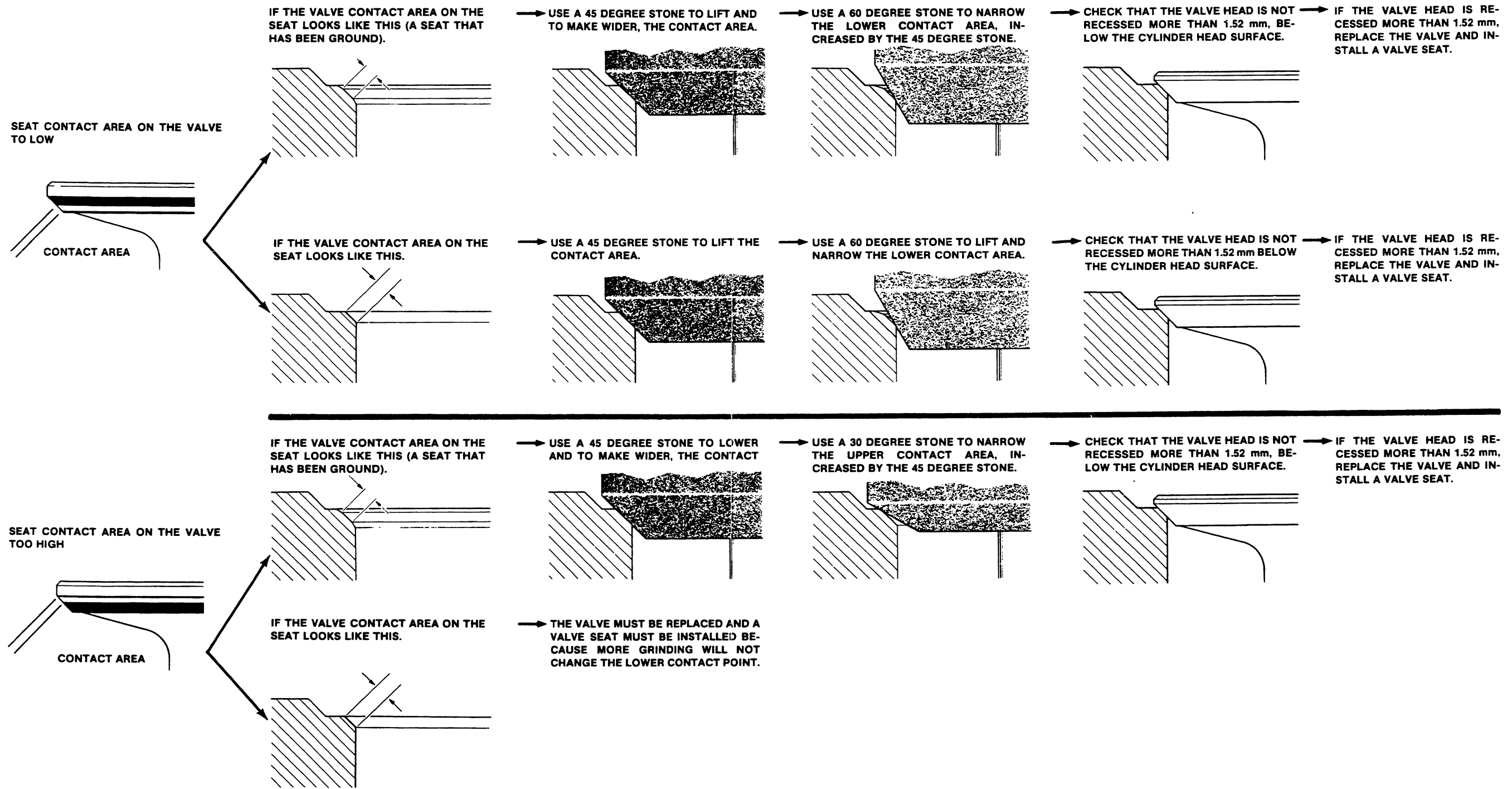

STEP 81

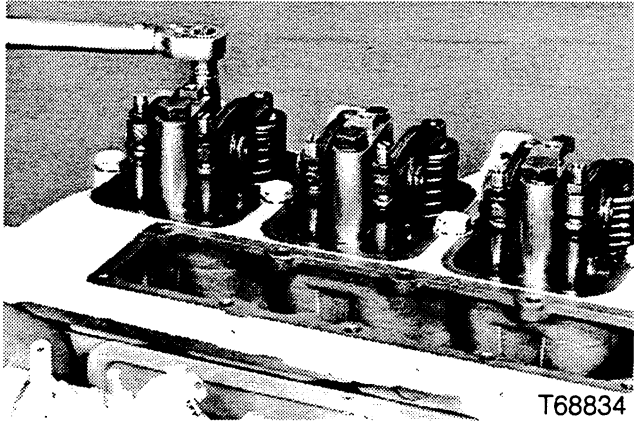

Tighten the rocker shaft bracket bolt to a torque of 21 to 27 Nm.

STEP 82

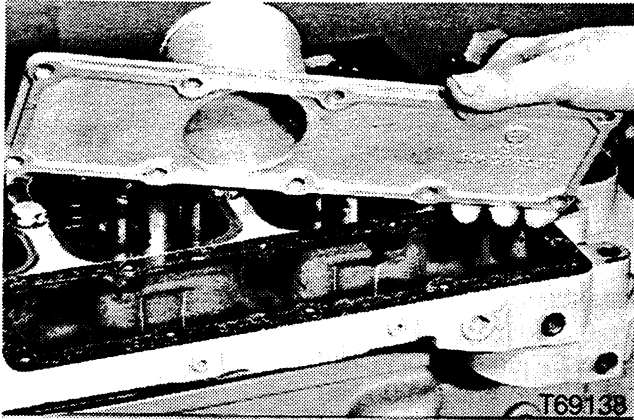

Install the intake manifold gasket and the intake manifold.

STEP 83

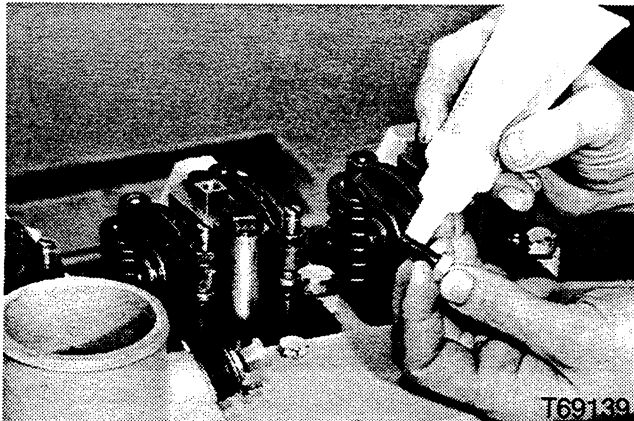

Put Loctite liquid teflon on the intake manifold bolts.

STEP 84

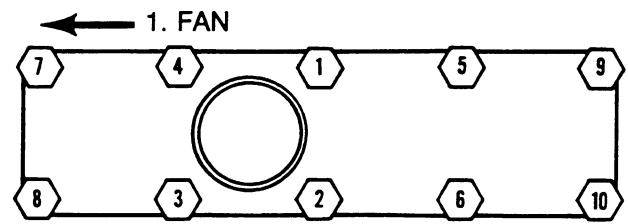

B902916J

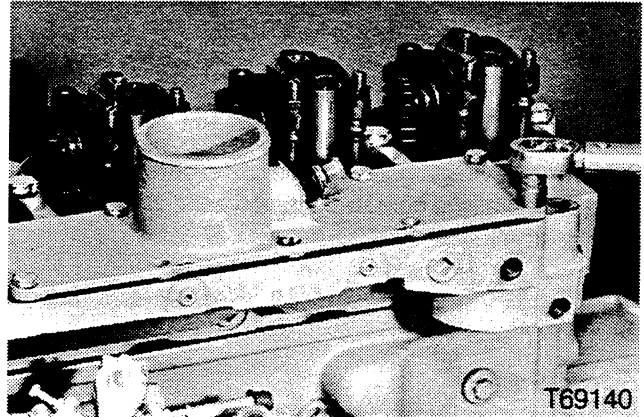

Install the intake manifold bolts and tighten to a torque of 21 to 27 Nm, following the torque sequence shown above.

STEP 85

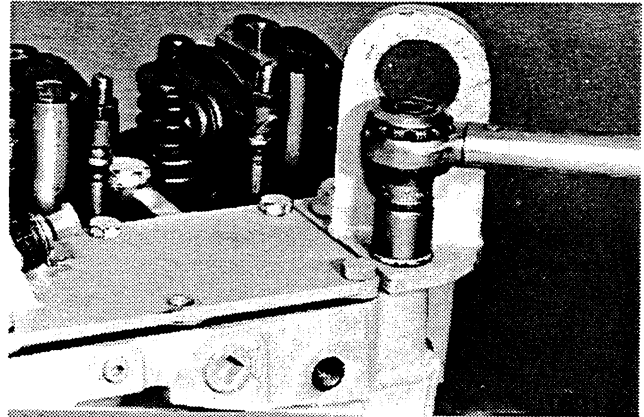

Install the rear lift bracket and tighten the bolts to a torque of 71 to 83 Nm.

TABLE OF CONTENTS

| | |
|---|-------|
| SPECIFICATIONS..... | 4-6 |
| Special Torques..... | 6 |
| SPECIAL TOOLS..... | 7-8 |
| FRONT OIL SEAL REPLACEMENT..... | 9-11 |
| REAR OIL SEAL REPLACEMENT..... | 12-15 |
| FRONT OIL SEAL AND WEAR SLEEVE INSTALLATION..... | 15-17 |
| REAR OIL SEAL AND WEAR SLEEVE INSTALLATION..... | 18-21 |
| REMOVAL OF PISTONS AND RODS..... | 21-22 |
| CYLINDER WALL INSPECTION..... | 23-26 |
| RECONDITIONING THE ENGINE CYLINDER BLOCK | |
| Checking and Resurfacing the Cylinder Block..... | 27 |
| Reconditioning the Cylinder Block for Oversize Pistons..... | 28 |
| Reconditioning the Cylinder Block for Sleeves..... | 29-30 |
| PISTON AND CONNECTING ROD DISASSEMBLY AND INSPECTION..... | 31-33 |
| PISTON AND CONNECTING ROD ASSEMBLY AND INSTALLATION..... | 33-38 |
| REPLACEMENT OF THE MAIN BEARINGS WITHOUT REMOVING THE CRANKSHAFT..... | 38-41 |
| CRANKSHAFT AND MAIN BEARINGS..... | 41-45 |
| CRANKSHAFT GEAR REMOVAL..... | 46 |
| CRANKSHAFT INSPECTION..... | 46 |
| CRANKSHAFT RECONDITIONING | |
| Grinding a Crankshaft..... | 47 |
| Crankshaft Rehardening..... | 47 |
| CRANKSHAFT GEAR INSTALLATION..... | 48 |
| CRANKSHAFT INSTALLATION..... | 48-57 |

REAR OIL SEAL REPLACEMENT

STEP 19

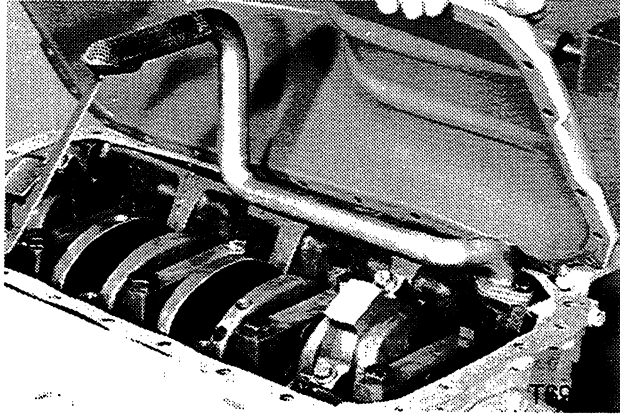

Remove the engine oil pan. See Section 2445 for oil pan removal.

STEP 22

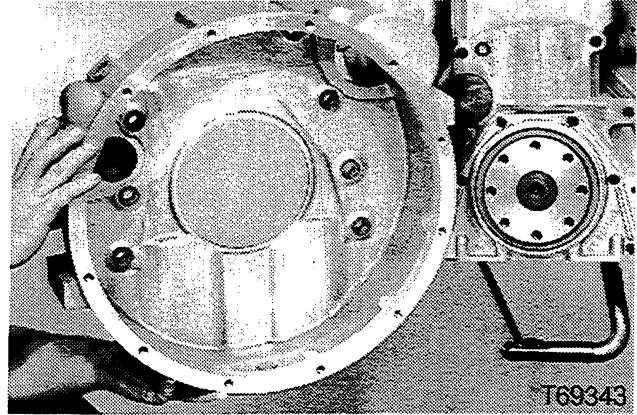

Remove the bolts and the flywheel housing from the engine block.

STEP 20

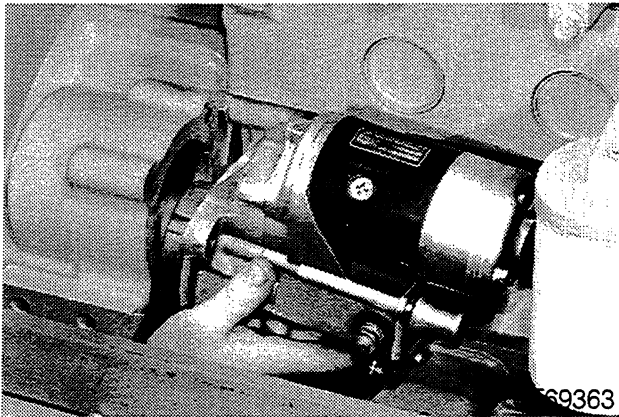

Remove the bolts and the starter from the flywheel housing.

STEP 23

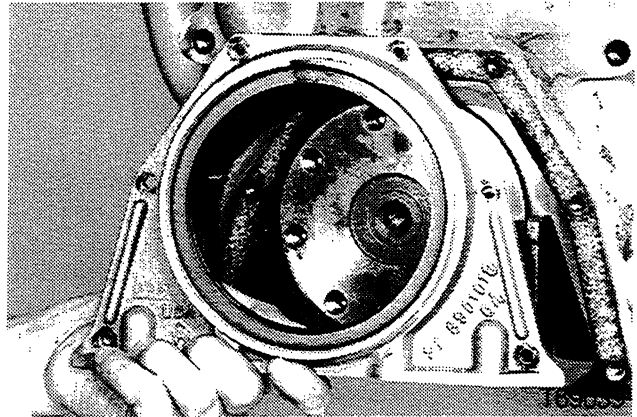

Remove the seal carrier from the crankshaft.

STEP 21

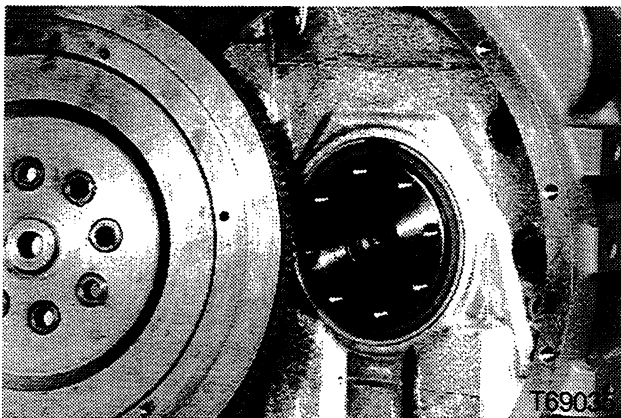

Remove the bolts and the flywheel from the flywheel housing.

STEP 24

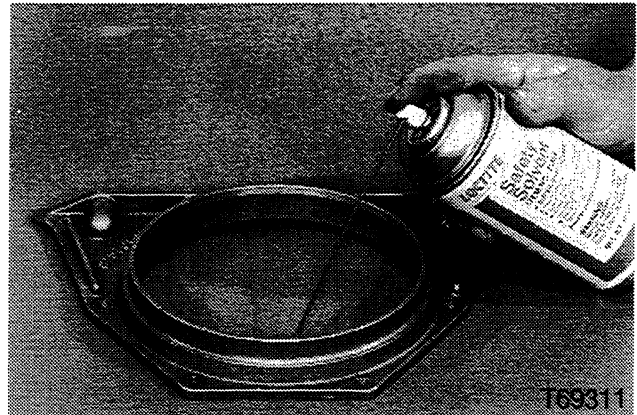

Remove the seal and clean the seal surface with Loctite safety solvent.

STEP 80

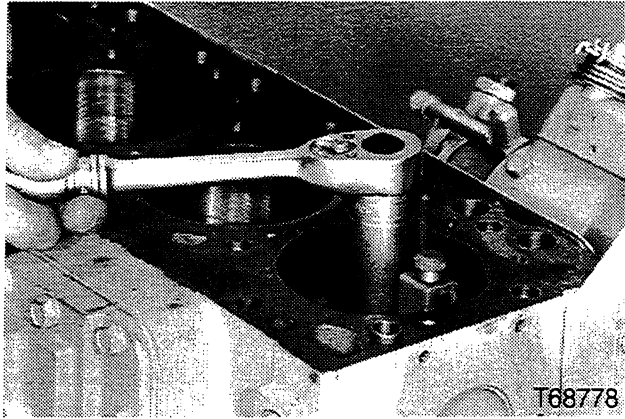

Install a ridge reamer and remove the ridge from the cylinder walls.

STEP 81

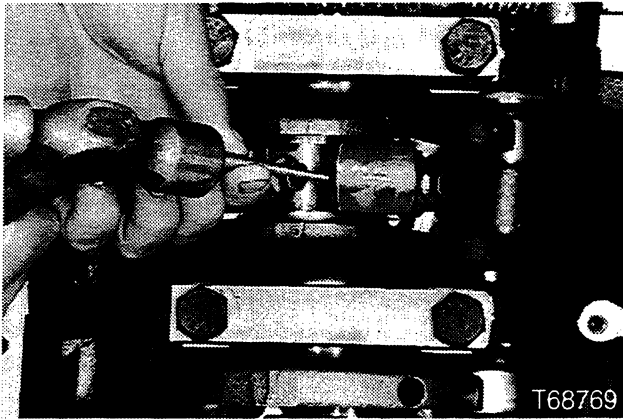

Put a mark on each rod cap for cylinder identification.

STEP 82

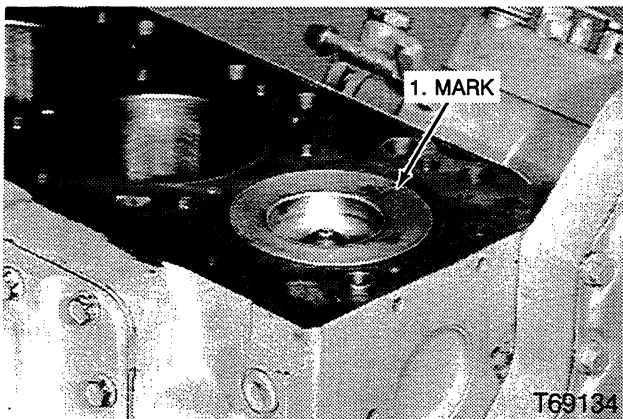

Put an identification mark on each piston for assembly.

STEP 83

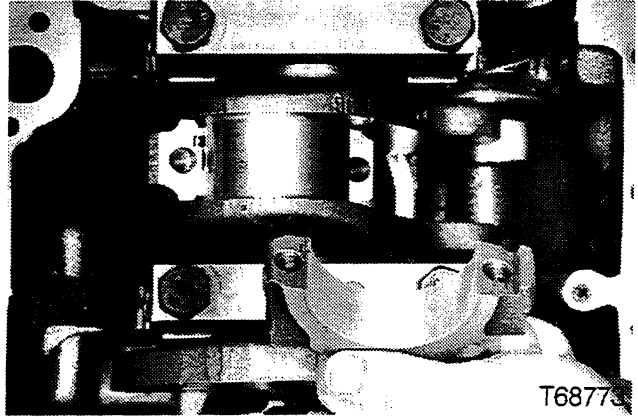

Remove the rod cap.

STEP 84

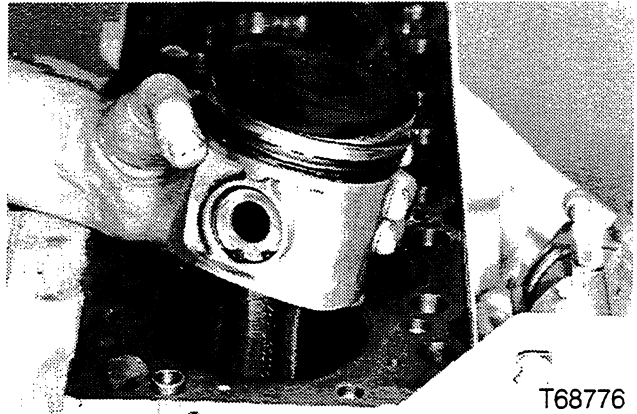

Remove the pistons from the top of the engine block.

STEP 108

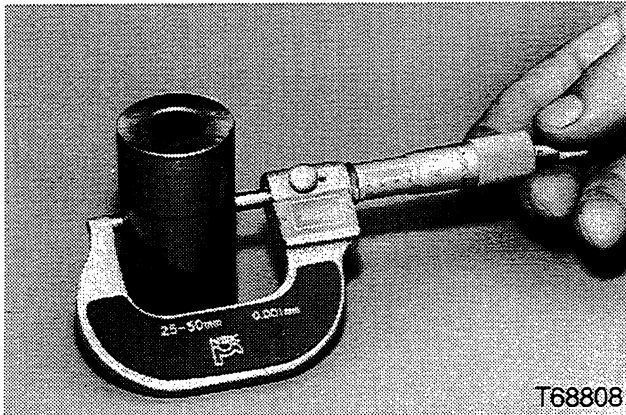

Measure the diameter of the piston pin. If the diameter is less than 39.990 mm the piston pin must be replaced.

STEP 109

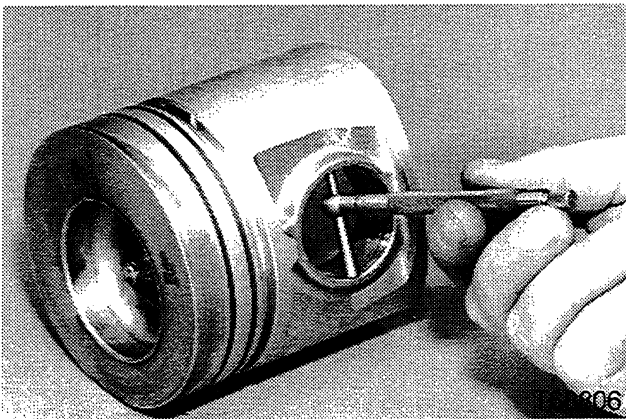

Measure the piston pin bore. If the piston pin bore is more than 40.025 mm the piston must be replaced.

STEP 110

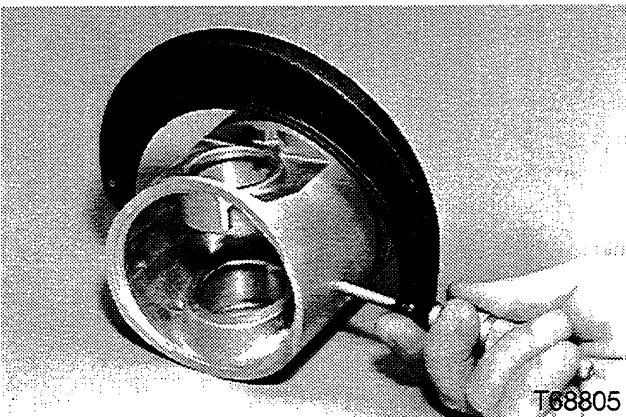

Measure the diameter of the piston across the thrust face 12 mm from the bottom of the piston at right angles to the piston pin holes. Replace the piston if the diameter is less than 101.823 mm.

STEP 111



Break an old piston ring in half and use the broken ring half to clean the piston ring grooves. Too much deposit in the ring grooves can force the rings out and will cause scoring.

STEP 112

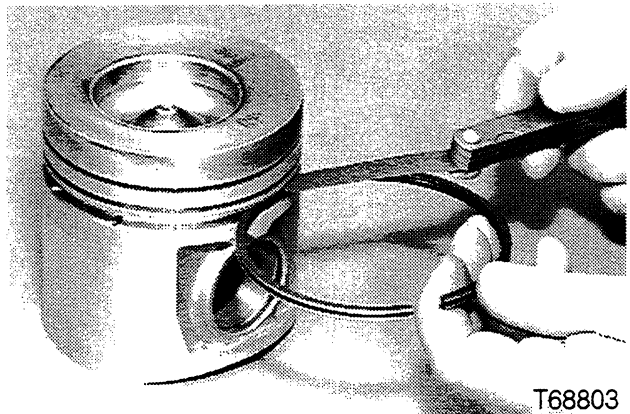

Check the side clearance of the oil ring in the piston. Insert a feeler gauge between the upper surface of a new ring and the piston lands to check the clearance. Replace the piston if side clearance is more than 0.13 mm.

STEP 113

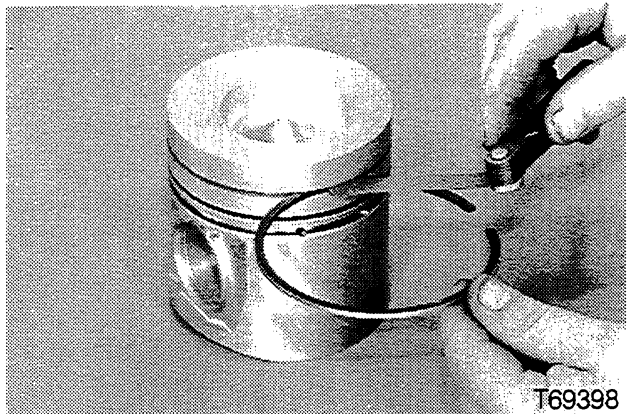

Check the side clearance of the first and second compression rings. Replace the piston if the side clearance is more than 0.15 mm.

STEP 162

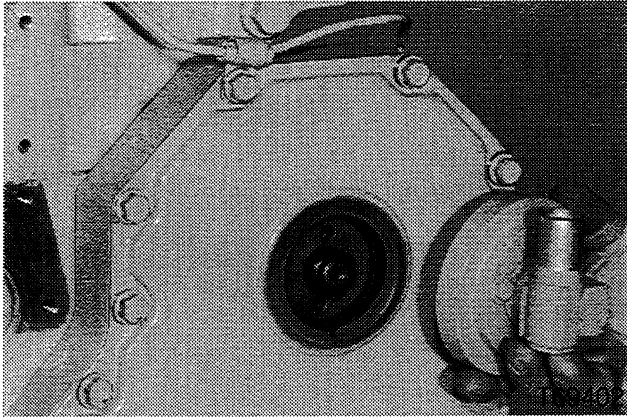

Remove the tachometer, if equipped.

STEP 163

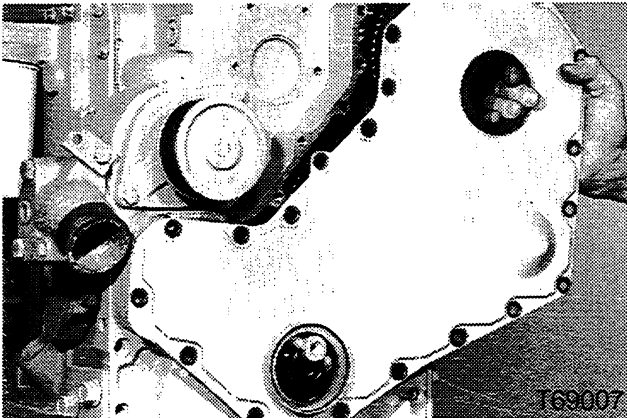

Remove the bolts and the front cover.

STEP 164

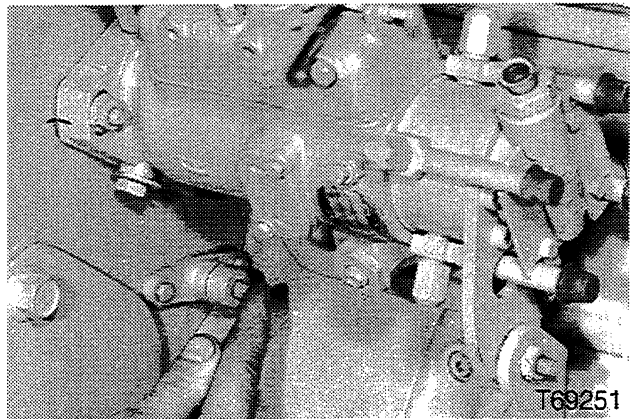
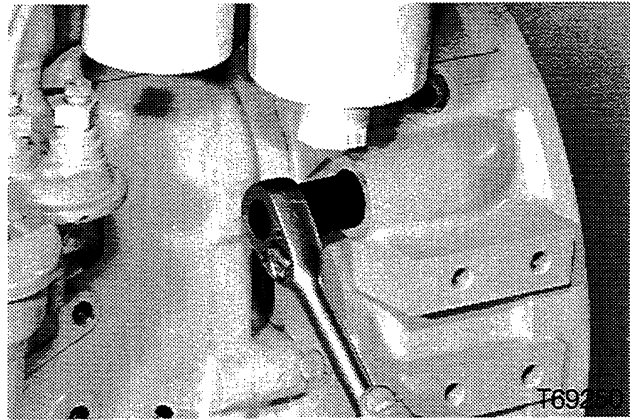

Turn the engine over with a engine rotating tool and push the lock into the camshaft gear.

STEP 165 BOSCH INJECTION PUMP

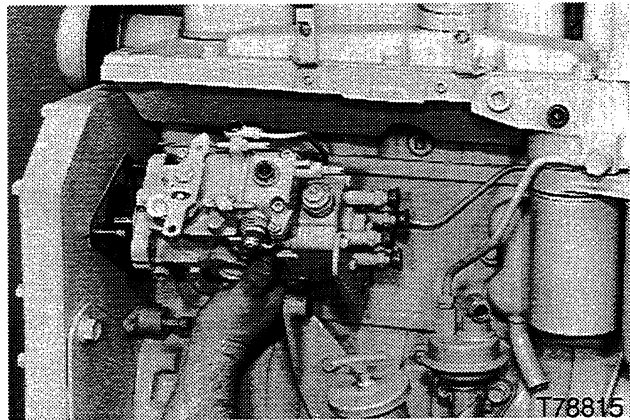

Remove the injection pump and primer pump. See Section 3415 in the service manual.

STEP 212

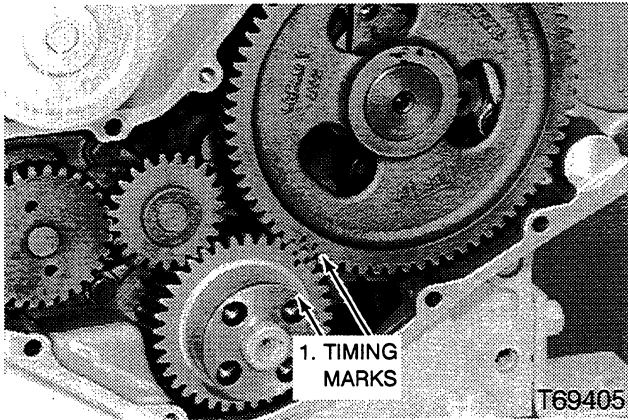

Make sure the timing marks on the crankshaft and camshaft are aligned.

STEP 213

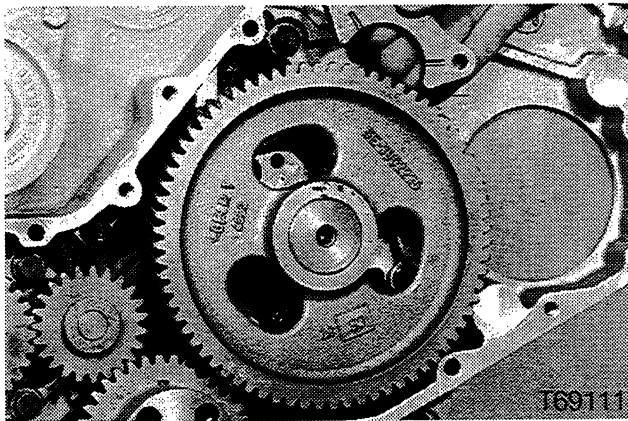

Install the camshaft thrust plate behind the camshaft gear.

STEP 214

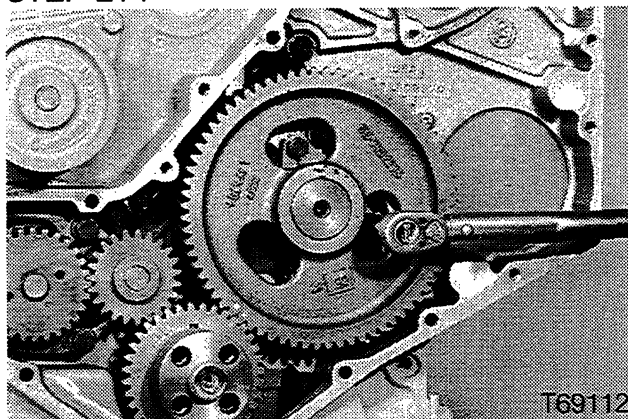

Install the thrust plate bolts and tighten to a torque of 21 to 27 Nm.

STEP 215

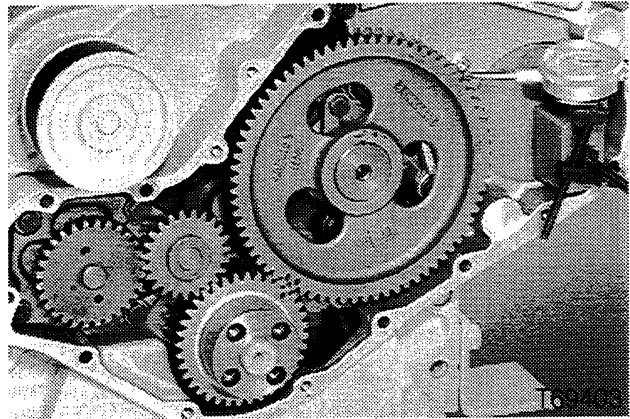

Put a dial indicator on the camshaft gear. Check the backlash between the camshaft gear and the crankshaft gear. Backlash must be 0.08 to 0.33 mm. If backlash is more than 0.45 mm the gears must be replaced.

NOTE: Too much backlash can also be caused by worn camshaft bushings.

STEP 216

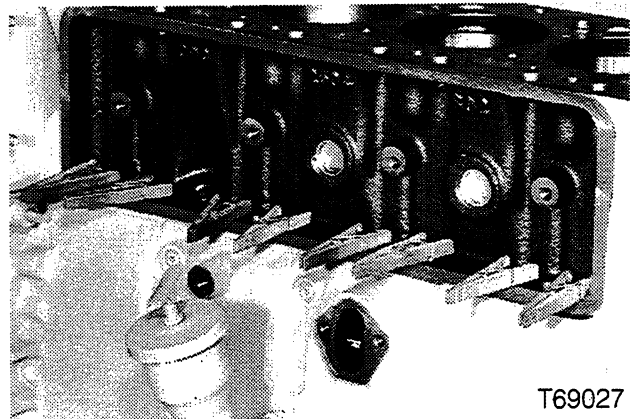

Remove the pins from the lifters.

STEP 217

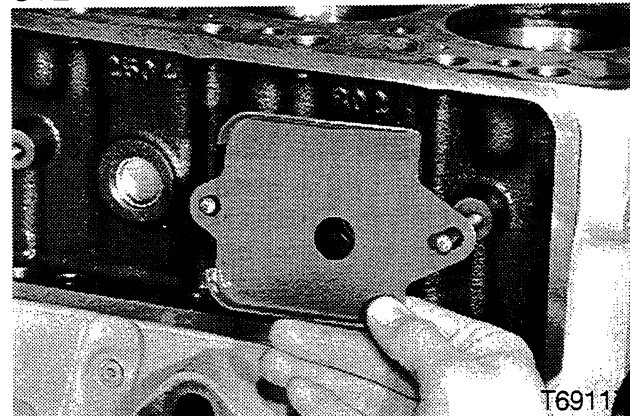

Install the breather cover.

Camshaft Disassembly and Inspection

STEP 267

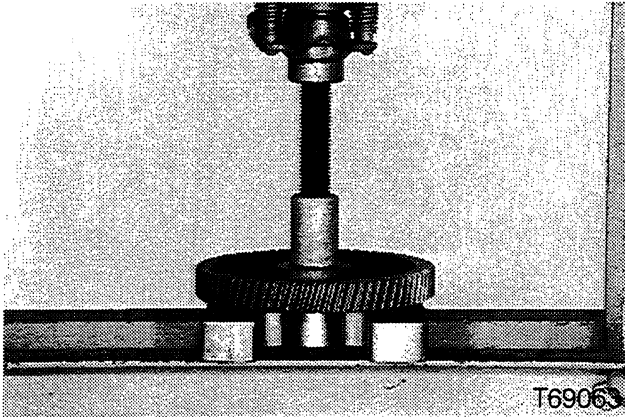

Press the gear off the camshaft.

STEP 268

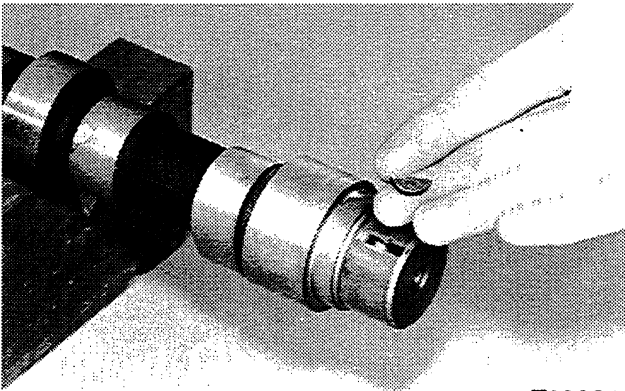

Remove the shaft key.

STEP 269

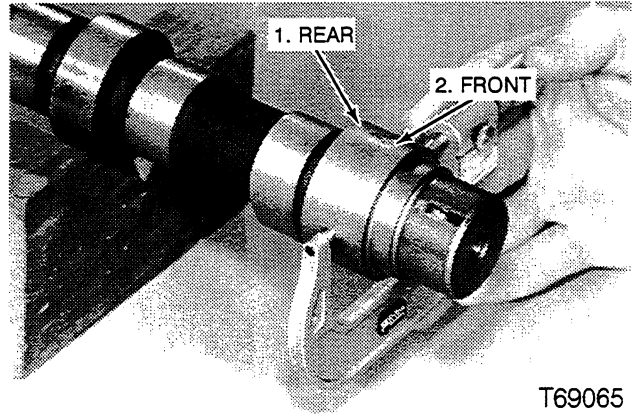

Measure the front and rear of each bearing surface on the camshaft. Use a micrometer.

STEP 270

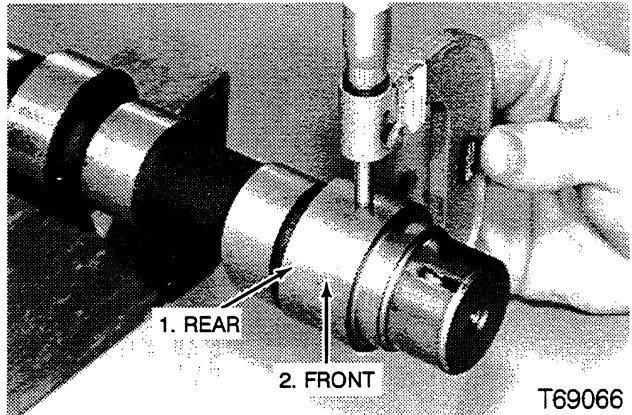

Each bearing surface must be measured in four positions. Measure the front and rear bearing surfaces again, 90 degrees from the first measurement.

NOTE: *Replace the camshaft if the outside diameter of any bearing surface is less than 53.962 mm.*

22.5 mm Expansion Plug

STEP 311



Remove the expansion plug from the cylinder block.

STEP 314

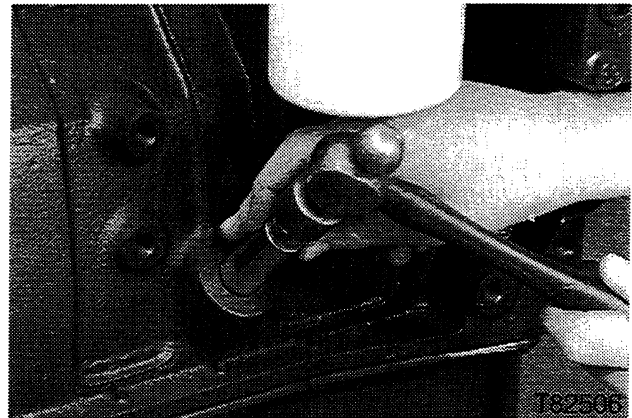
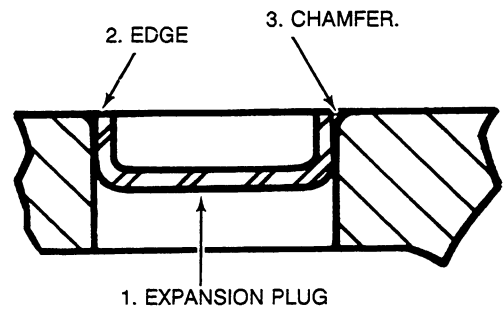

Install the expansion plug into the bore, until the top edge of the expansion plug is even with the bottom edge of the chamfer.

STEP 312



Clean the expansion plug bore of all foreign material, use Loctite safety solvent.

STEP 313



Apply Loctite 277 to the sealing surface of the expansion plug.

OIL PUMP Removal

STEP 1

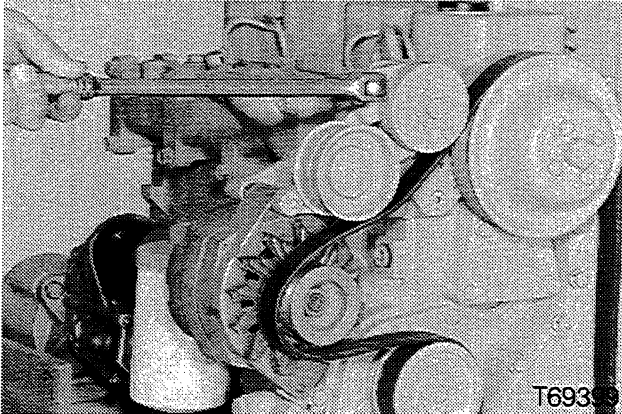

Lift the belt tensioner pulley and remove the fan belt.

STEP 4

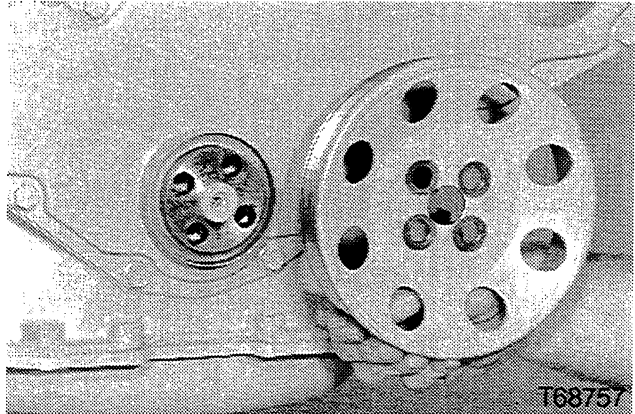

Remove the crankshaft pulley bolts and the pulley.

STEP 2

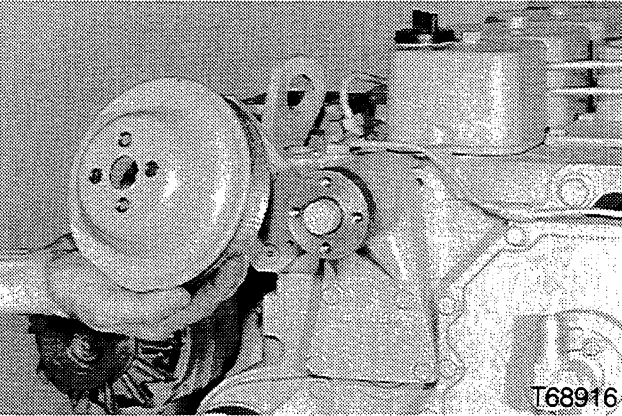

Remove the retaining bolts and fan belt pulley.

STEP 5

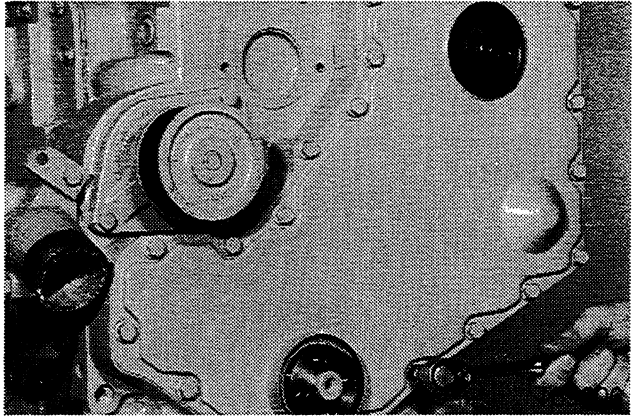

Remove the front cover retaining bolts and remove the front cover.

STEP 3

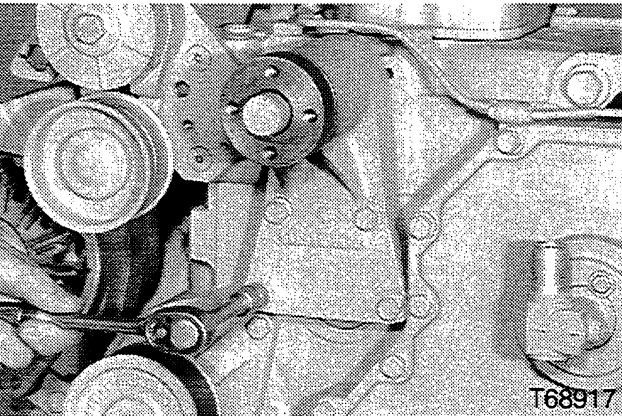

Remove the fan pulley bracket retaining bolts and fan pulley bracket.

STEP 6

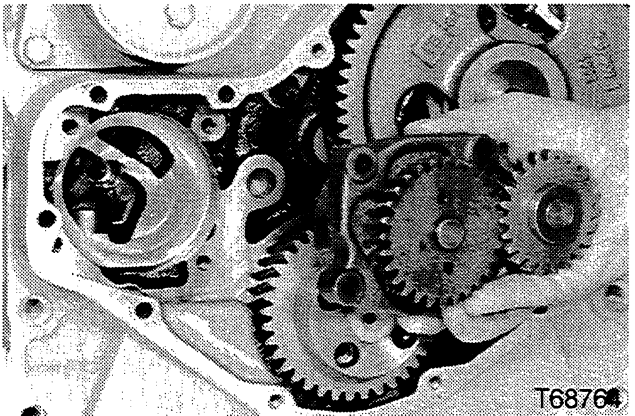

Remove the oil pump bolts and the oil pump.

WATER PUMP Removal

STEP 1

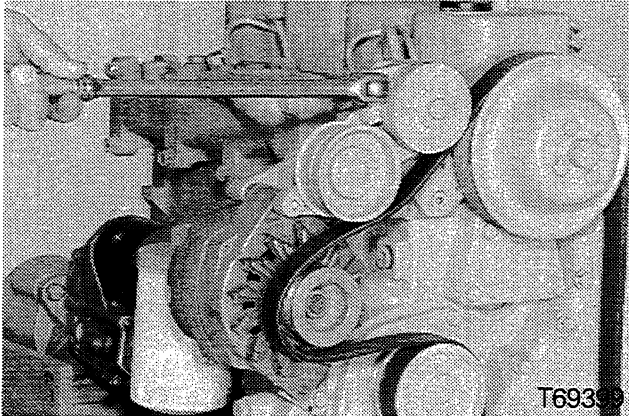

Lift the belt tensioner pulley and remove the fan belt.

STEP 2

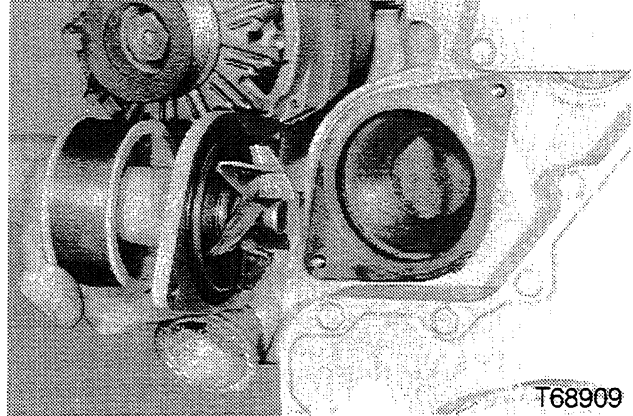

Remove the water pump bolts and the water pump.

Installation

STEP 3

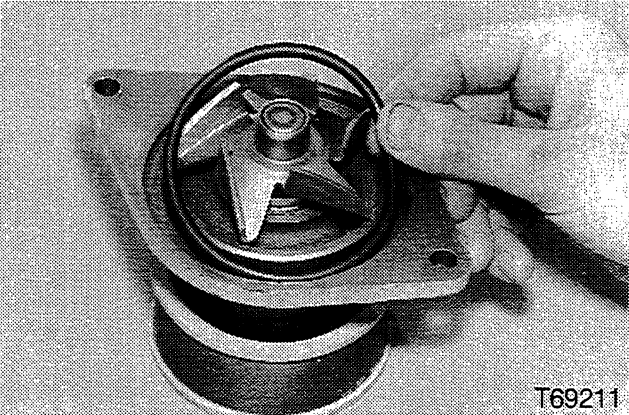

Install a new o-ring into the water pump housing.

STEP 5

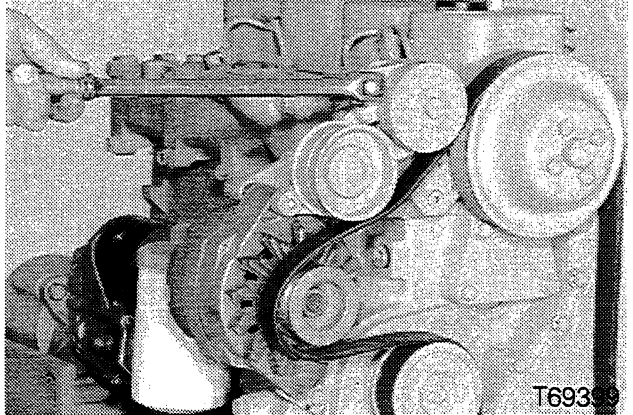

Lift the belt tensioner pulley and install the fan belt.

STEP 4

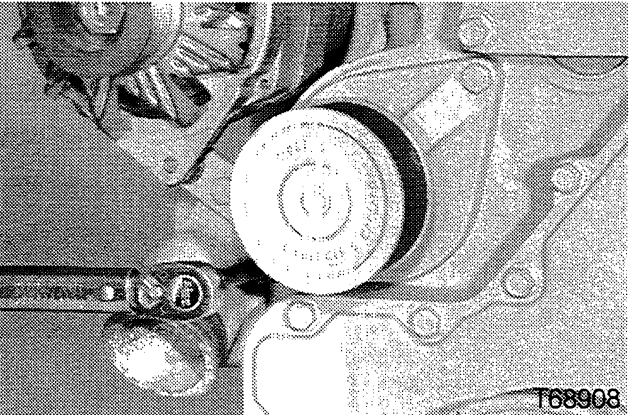

Install the water pump and tighten the water pump retaining bolts to a torque of 21 to 27 Nm.

THERMOSTAT SERVICE

STEP 44

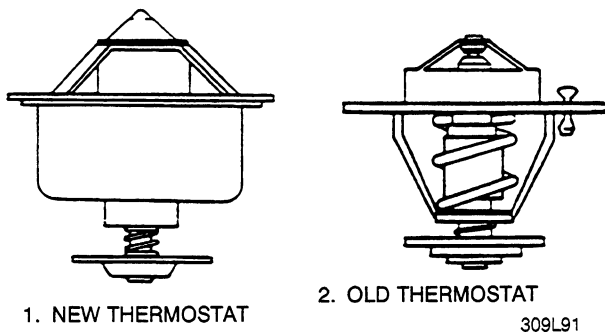

1. NEW THERMOSTAT

2. OLD THERMOSTAT

309L91

A new thermostat has been released for use in your engine. If you removed an old thermostat from your engine, do the following steps to install a new thermostat.

STEP 45

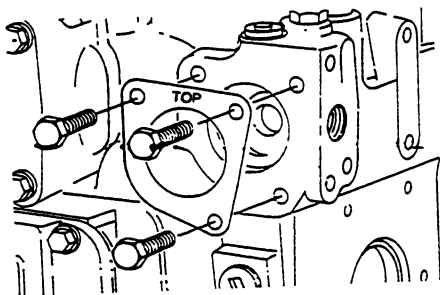

311L91

Install the template that comes with the new thermostat kit.

STEP 46

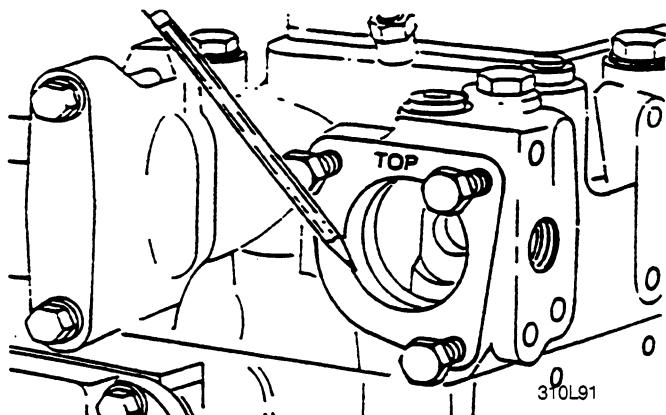

310L91

If the cylinder head coolant passage is smaller than the ID of the template, the coolant passage will have to be made larger. Mark the ID of the template on the cylinder head.

STEP 47

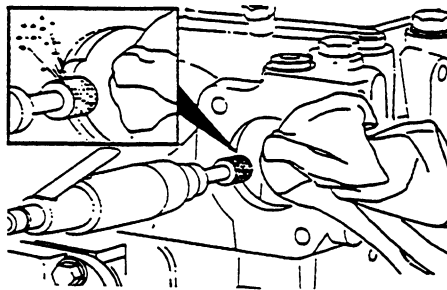

312L91

Remove the template. Use a shop cloth in the coolant passage to keep foreign material out of the engine. Use a rotary grinder to remove the material.

STEP 48

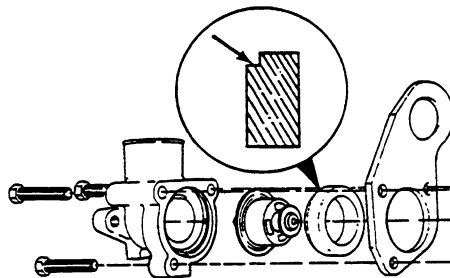

31391

Remove all foreign material from the cylinder head. Install the seal and new thermostat. Tighten the bolts to a torque of 21 to 27 Nm.

STEP 49

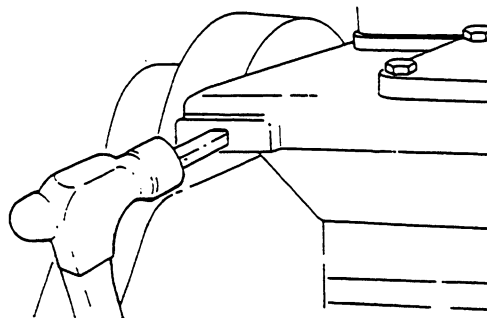

314L91

Mark the cylinder head on the intake side next to the serial number as follows:

Stamp the letter "G" for cylinder heads that were inspected and did not need to be machined.

Stamp the letter "M" for cylinder heads that were machined.

STEP 31



Make the tabs straight on the lock plate.

STEP 32

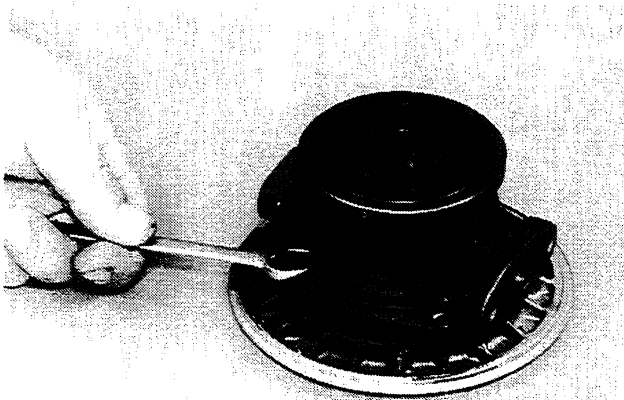

Remove the retaining bolts from the center housing.

STEP 33



Remove the lock plates from the center housing.

STEP 34

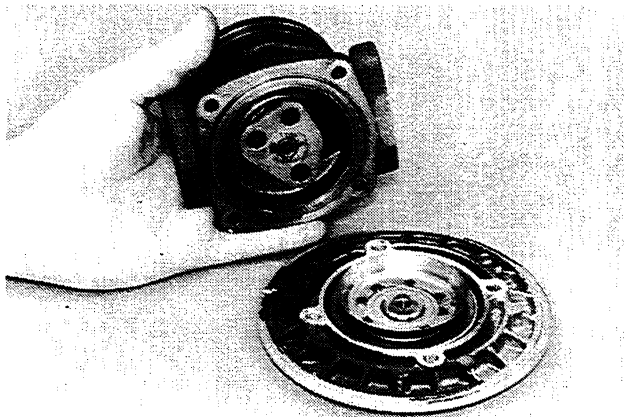

Remove the center housing from the back plate.

STEP 35

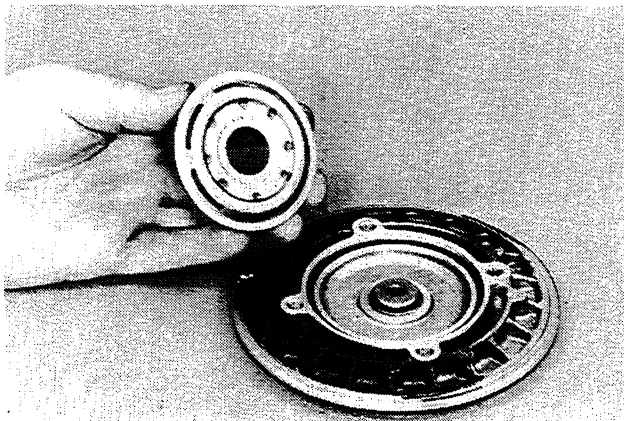

Remove the oil baffle from the back plate.

STEP 36

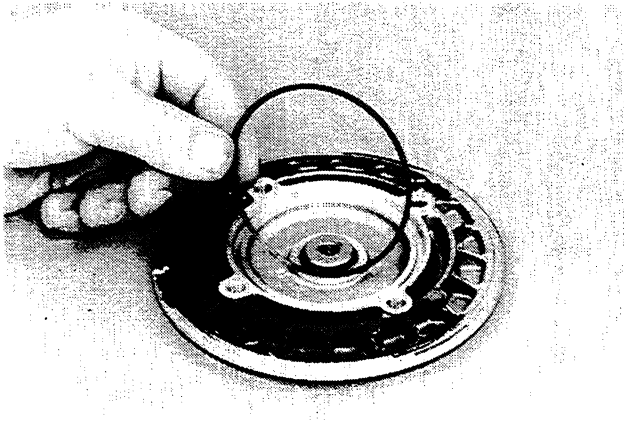

Remove the seal from the back plate.

STEP 82

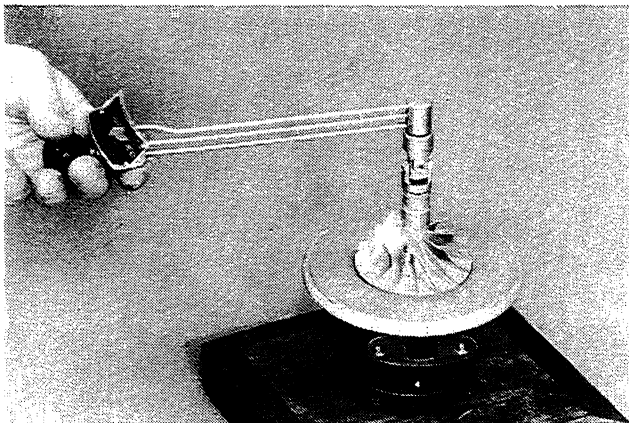

Tighten the lock nut to a torque of 120 lb inch (14 Nm)(1.4 kgm).

STEP 83



Remove the center housing assembly from the fixture.

STEP 84



Carefully install the center housing on the turbine housing. Make sure the mark on the turbine housing is in align with the mark on the center housing.

STEP 85



Install the clamp plates and the new lock plates.

Compressor Blade Erosion

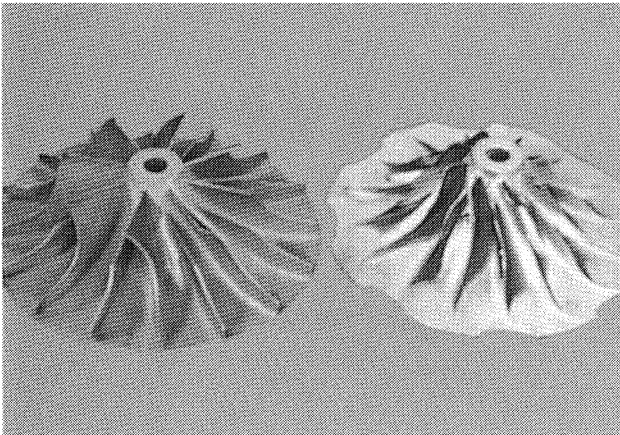

Erosion of compressor blades from ingestion of dust. Blades on one wheel are thinned while the other wheel is almost completely worn away. Fine erosion of the inlet edges of the compressor wheel suggests sand or other fine abrasive in the inlet system, entering through a damaged air cleaner element or a leak in inlet piping. There will generally be no damage to the turbine wheel or bearings unless the problem was so severe that the rotating unit became unbalanced.

Turbine Wheel Damage

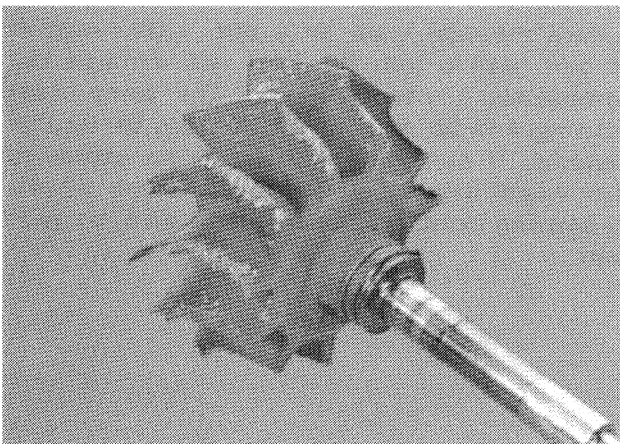

Foreign material in the exhaust system will cause chipped or broken turbine wheel blades. Foreign material is usually something left by accident in the exhaust manifold, or debris from an engine component such as a valve which failed. If damage is extreme, the turbine wheel balance will be destroyed and further damage will occur. If you find this problem checkout the engine.

Turbine Shaft Discoloration

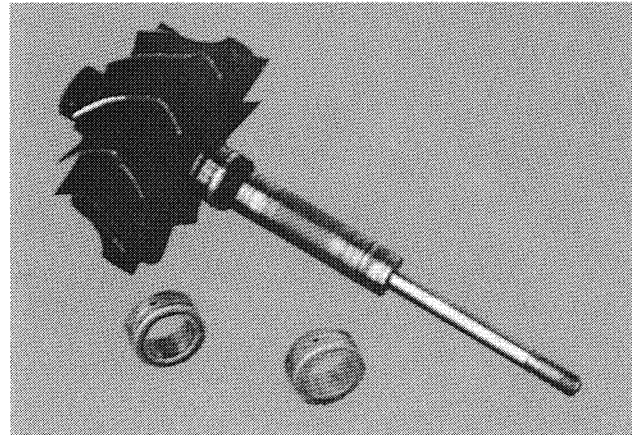

Discoloration of the turbine shaft is due to overheating caused by oil starvation. Lack of lubrication generally is a matter of improper start-up or shut-down practices.

Backing Plate Wheel Rub

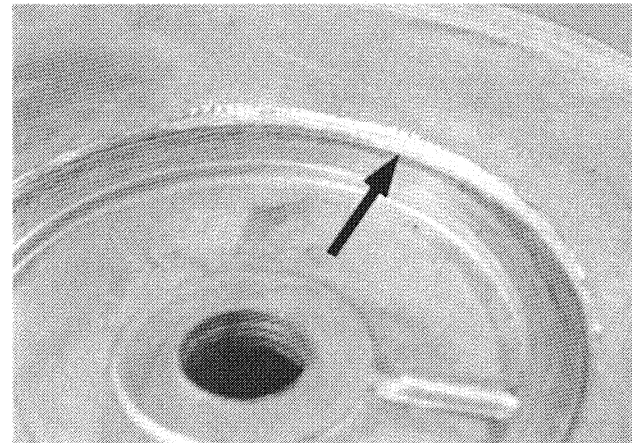

Wheel rub against the backing plate can be caused by a bent shaft or improper assembly.

Cleaning and Inspection

1. All parts must be put in a solvent to loosen the carbon deposits.
2. Use the Nozzle Cleaning Kit, OEM 1068, to clean the injectors. A brass wire brush must be used to clean the outside of the tip body. Use cleaning wires to remove the carbon from the spray orifices. Use cleaning wires that are 0.0127 to 0.0254 mm smaller in diameter than the spray orifice. Put the cleaning wire in a pin vise, the end of the wire must extend 0.79 mm past the tip of the pin vise. A longer length of pin will hit the opposite side of the sac hole and will break.

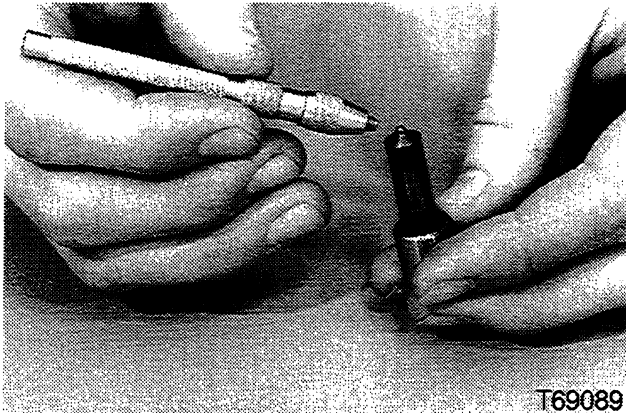

T69089

3. Use a stone to remove sharp edges from the end of the wire. A small flat on one side of the wire will make it easier to cut the carbon from the orifice. Put the cleaning wire in the spray orifice and turn the wire until the wire is free. Wash the body with clean solvent and look at the tip. The nozzle tip must be replaced if the orifice in the tip shows damage at the edges. Damage to the orifice will change the spray pattern.

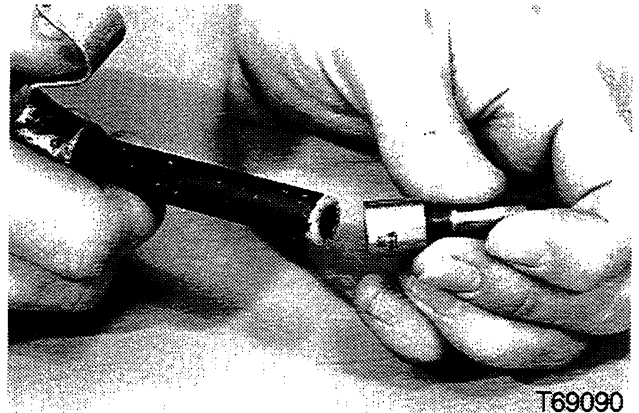

T69090

4. Clean all channels with compressed air. Direct the air through both ends of the nozzle tip assembly. All Carbon deposits must be removed.



T69088

5. Make sure that the nozzle valve slides freely in the nozzle body.
6. Carefully clean the nozzle valve and the inside diameter of the body to remove all dirt, varnish and other foreign deposits.
7. The injector valve must be cleaned with a brush to remove deposits from the seat location. Varnish must be removed with a solvent and a cleaning pad made of felt. Do not put the valve in a motor driven lathe to clean the valve. This method can remove too much material from the valve which can change valve lift. Look at the valve for pitting or damage which can cause leakage.
8. Replace all parts that show damage.

STEP 6

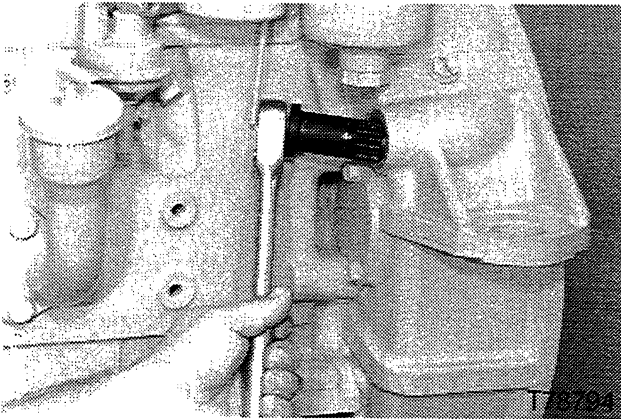
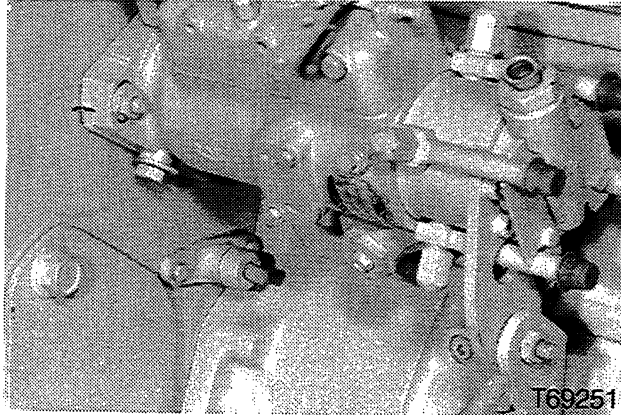

Install the engine turn over tool, CAS 1690, and push in on the lock pin. Turn the engine over until the lock pin engages in the camshaft gear.

STEP 7

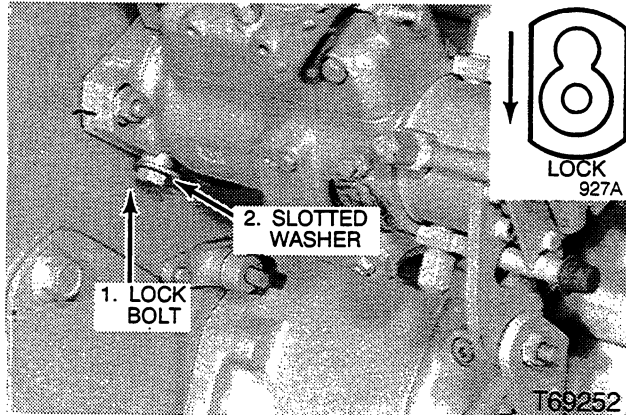

Loosen the pump shaft lock bolt and move the slotted washer off the lock bolt shoulder. Tighten the lock bolt to a torque of 7 Nm.

NOTE: The slotted washer must be loose after the lock bolt had been tightened.

STEP 8

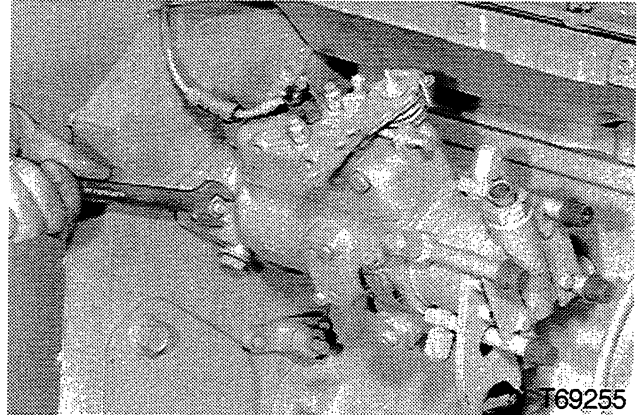

Loosen the injection pump retaining nuts and bracket bolts.

STEP 9

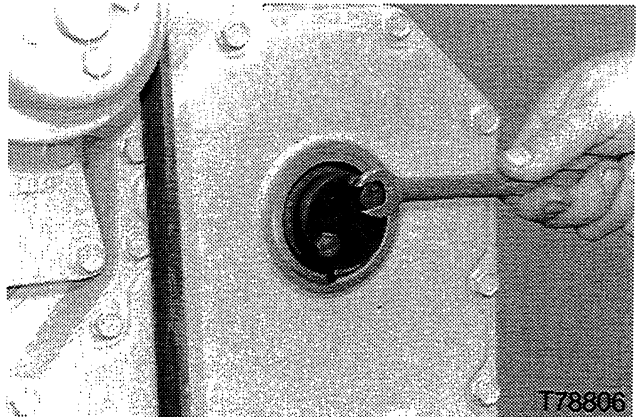

Install the gear puller, CAS 1691, and tighten the bolts until the gear is loose on the pump shaft.

STEP 10

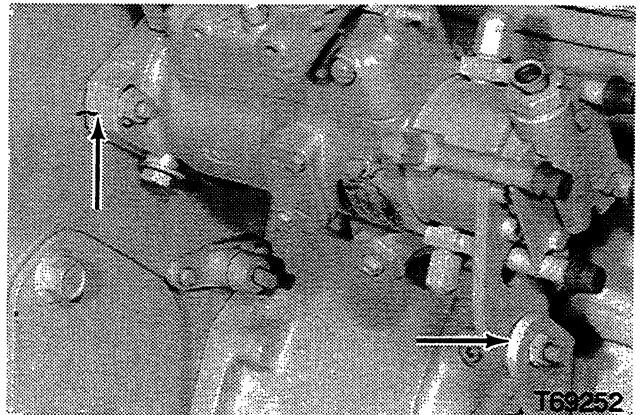

Remove the retaining nuts and bracket bolts. Remove the injection pump and discard the gasket.

NOTE: Care must be taken when removing the pump from the gear not to lose the key from the pump shaft. If the key is not on the shaft, it is necessary to remove the timing cover.

PRIMER PUMP Removal

STEP 55

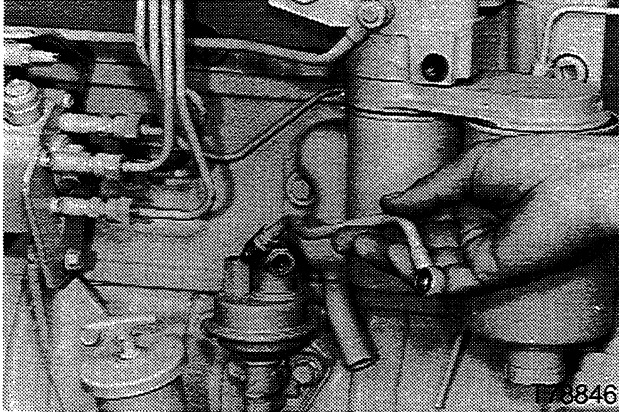

Disconnect and remove the fuel inlet line.

STEP 56

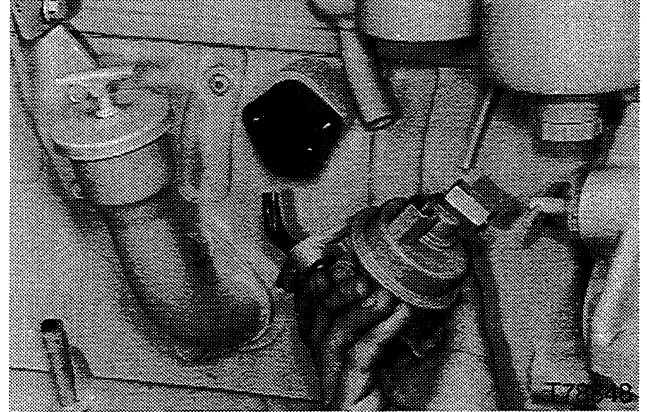

Remove the primer pump bolts and the primer pump from the cylinder block.

Installation

STEP 57

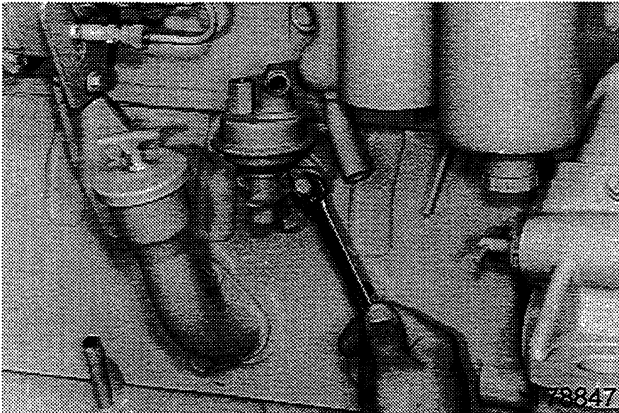

Install the primer pump and tighten the bolts that hold the primer pump to the cylinder block.

STEP 59

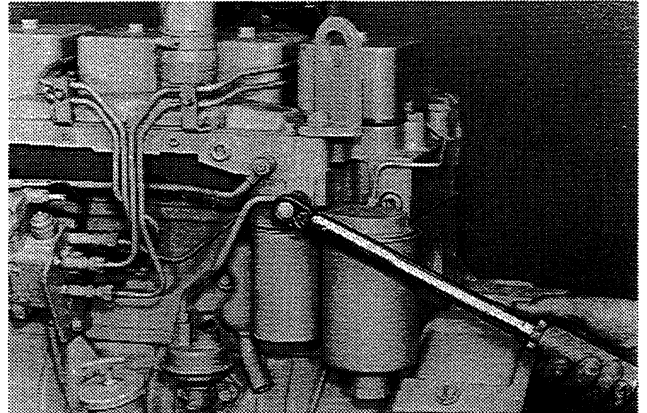

Tighten the inlet fitting to a torque of 22 to 28Nm.

STEP 58

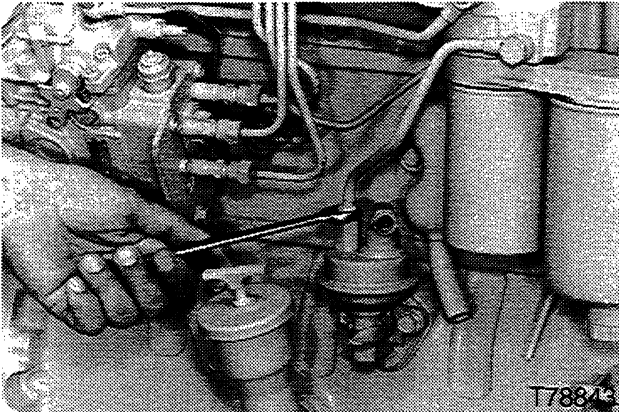

Connect and tighten the fuel inlet line to the primer pump.

STEP 25

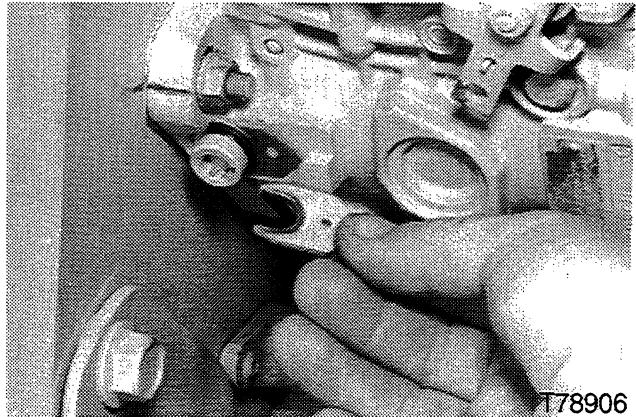
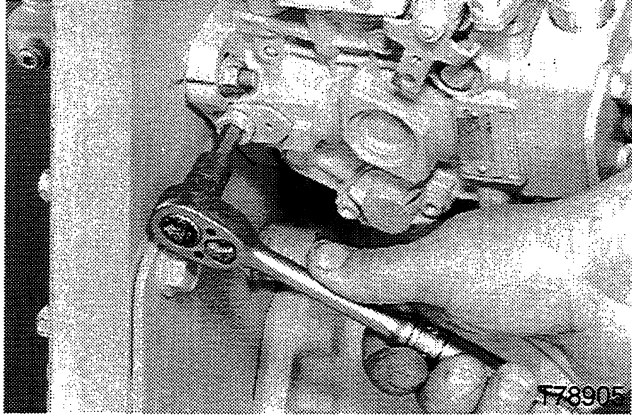

Loosen the lock bolt and remove the slotted tab.

STEP 26

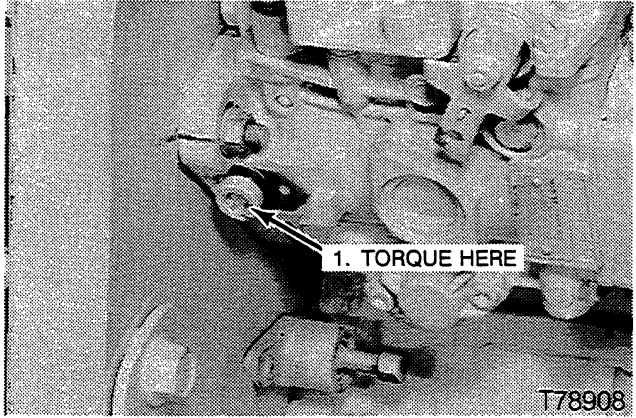

Tighten the lock bolt to a torque of 27 to 33 Nm.

STEP 27

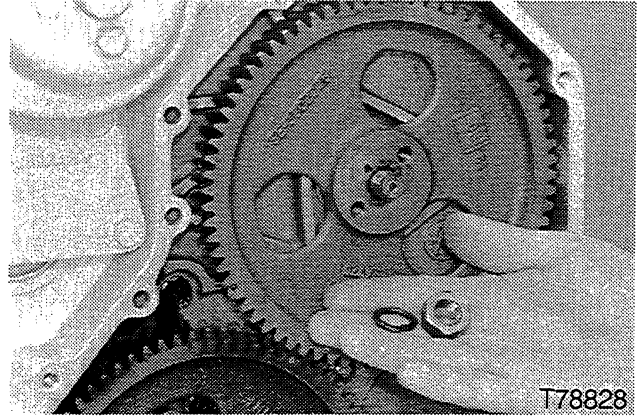

Remove the nut and washer from the injection pump shaft.

STEP 28

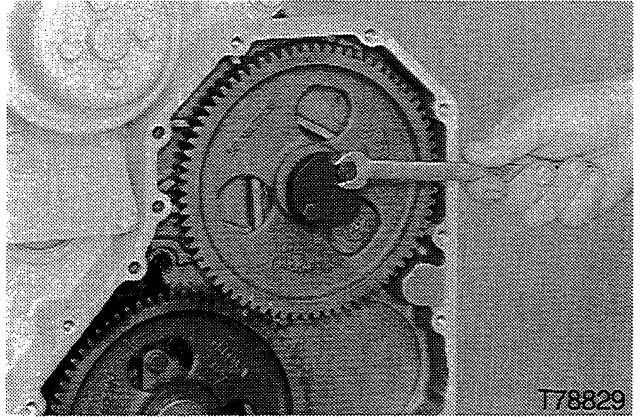

Install the gear puller and tighten the bolts until the gear is loose on the injection pump.

Installation

STEP 71

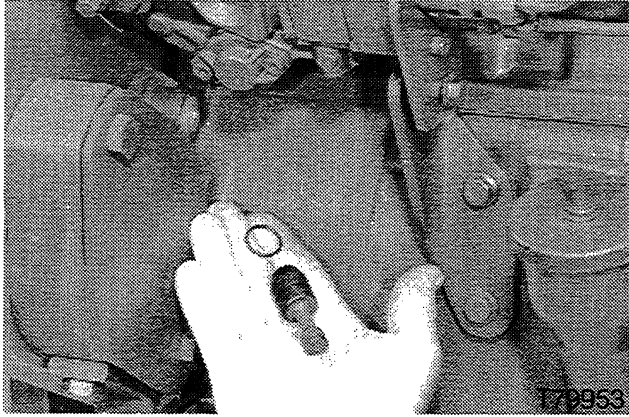

Install a new o-ring onto the locking pin.

STEP 72

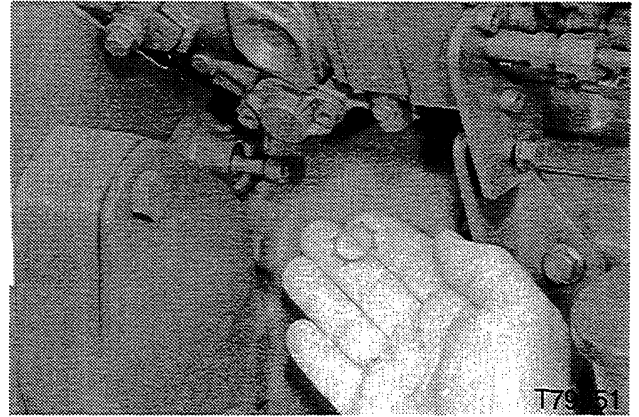

Install the lock pin. Install the retaining ring into the locking pin housing.

TABLE OF CONTENTS

| | |
|---|----|
| SPECIFICATIONS | 3 |
| ELECTRICAL CIRCUIT CHECKS | 4 |
| Master Disconnect Switch | 4 |
| Battery | 4 |
| Starter and Starter Solenoid..... | 4 |
| Alternator Indicator Lamp | 5 |
| Alternator | 5 |
| Engine Oil Pressure Switch..... | 5 |
| Hourmeter | 6 |
| Fuse Block | 6 |
| Starter Relay..... | 7 |
| Normally Open Brake Relay | 7 |
| Normally Closed Brake Relay | 8 |
| Brake Solenoid..... | 8 |
| Key Switch..... | 9 |
| Ether Injection Switch..... | 9 |
| Ether Injection Temperature Switch | 10 |
| Ether Injection Solenoid | 10 |
| Transmission Filter Warning Lamp | 11 |
| Engine Run Switch..... | 11 |
| Fuel Shutoff Solenoid..... | 11 |
| Lamp Switch..... | 12 |
| Instrument Panel Lamps | 12 |
| Horns | 12 |
| Horn Button | 12 |
| Neutral Start Switch..... | 13 |
| Transmission Filter Switch | 13 |
| Backup Alarm Pressure Switch..... | 13 |
| Backup Alarm..... | 14 |
| LH Front Work Lamp..... | 14 |
| RH Front Work Lamp | 14 |
| RH Rear Lamp | 14 |
| LH Rear Lamp..... | 14 |
| ELECTRICAL SCHEMATIC..... | 15 |
| USING BOOSTER BATTERIES TO START THE ENGINE | 16 |

(20) Lamp Switch

NOTE: Put the master disconnect switch in the ON position.

| <u>Check Points</u> | <u>Reading</u> | <u>Possible Cause of Bad Reading</u> |
|----------------------------------|----------------|---|
| Terminal for wire 19A to ground. | 12 volts | Check the circuit from the lamp switch through the fuse block to the positive post of the battery |

NOTE: Put the lamp switch in the ON position.

| | | |
|---------------------------------|----------|-----------------|
| Terminal for wire 42F to ground | 12 volts | Bad lamp switch |
|---------------------------------|----------|-----------------|

(21) Instrument Panel Lamps

| <u>Check Points</u> | <u>Reading</u> | <u>Possible Cause of Bad Reading</u> |
|--|----------------|--|
| Bulb. | Good | Bad bulb |
| Check between the housing of the instrument panel lamp and the instrument panel. | Continuity | Bad ground connection between the instrument panel lamp and the instrument panel |

NOTE: Do the checks for the lamp switch (20). If the lamp switch (20) is good, replace the instrument panel lamp.

(22) Horns

| <u>Check Points</u> | <u>Reading</u> | <u>Possible Cause of Bad Reading</u> |
|-------------------------------------|----------------|--------------------------------------|
| Terminal for ground wire to ground. | Continuity | Bad ground circuit. |

NOTE: Put the master disconnect switch in the ON position. Have another person hold down the horn button.

| | | |
|--------------------------------|----------|---|
| Terminal for wire 64 to ground | 12 volts | Check the wire between the horn and the horn button (23) Also check the horn button (23). |
|--------------------------------|----------|---|

(23) Horn Button

NOTE: Put the master disconnect switch in the ON position.

| <u>Check Points</u> | <u>Reading</u> | <u>Possible Cause of Bad Reading</u> |
|----------------------------------|----------------|--|
| Terminal for wire 19B to ground. | 12 volts | Check the circuit from the horn button through the fuse block to the positive post of the battery. |

NOTE: Have another person hold down the horn button.

| | | |
|---------------------------------|----------|------------------|
| Terminal for wire 64 to ground. | 12 volts | Bad horn button. |
|---------------------------------|----------|------------------|

CHARGING A BATTERY

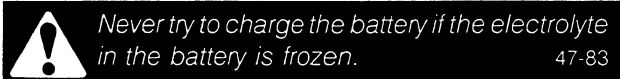

Before you charge the battery, check the level of the electrolyte.

It is difficult to give an exact charging rate because of the following variable conditions: (1) temperature of the electrolyte, (2) level of charge, and (3) condition of the battery. Use the charging guide for the correct charging rate and time.

See Specifications in Section 4002 for the reserve capacity of the battery in this machine.

The charging rate must be decreased if:

1. Too much gas causes the electrolyte to flow from the cells.
2. The temperature of the electrolyte rises above 125°F (52°C).

NOTE: *For the best charge, use the slow charging rates.*

The battery is fully charged when, over a three hour period at a low charging rate, no cell is giving too much gas, and the specific gravity does not change.

| CHARGING GUIDE FOR MAINTENANCE FREE BATTERIES | | |
|--|--|---|
| Recommended Rate* and Time for Fully Discharged Battery | | |
| Battery Capacity - See Reserve Capacity under Specifications, Section 4002 | Slow Charge | Fast Charge |
| 80 Minutes or Less | 10 Hours at 5 Amperes 5 Hours at 10 Amperes | 2.5 Hours at 20 Amperes 1.5 Hours at 30 Amperes |
| Above 80 to 125 Minutes | 15 Hours at 5 Amperes 7.5 Hours at 10 Amperes | 3.75 Hours at 20 Amperes 1.5 Hours at 50 Amperes |
| Above 125 to 170 Minutes | 20 Hours at 5 Amperes 10 Hours at 10 Amperes | 5 Hours at 20 Amperes 2 Hours at 50 Amperes |
| Above 170 to 250 Minutes | 30 Hours at 5 Amperes 15 Hours at 10 Amperes | 7.5 Hours at 20 Amperes 3 Hours at 50 Amperes |
| *Initial rate for standard taper charger. | | |

NOTE: *A maintenance free battery will have the words Maintenance Free on the decal on the top of the battery. If the center part of the decal has been removed to get*

access to the battery caps, it is possible the words Maintenance Free will have been removed from the decal.

Continued on next page

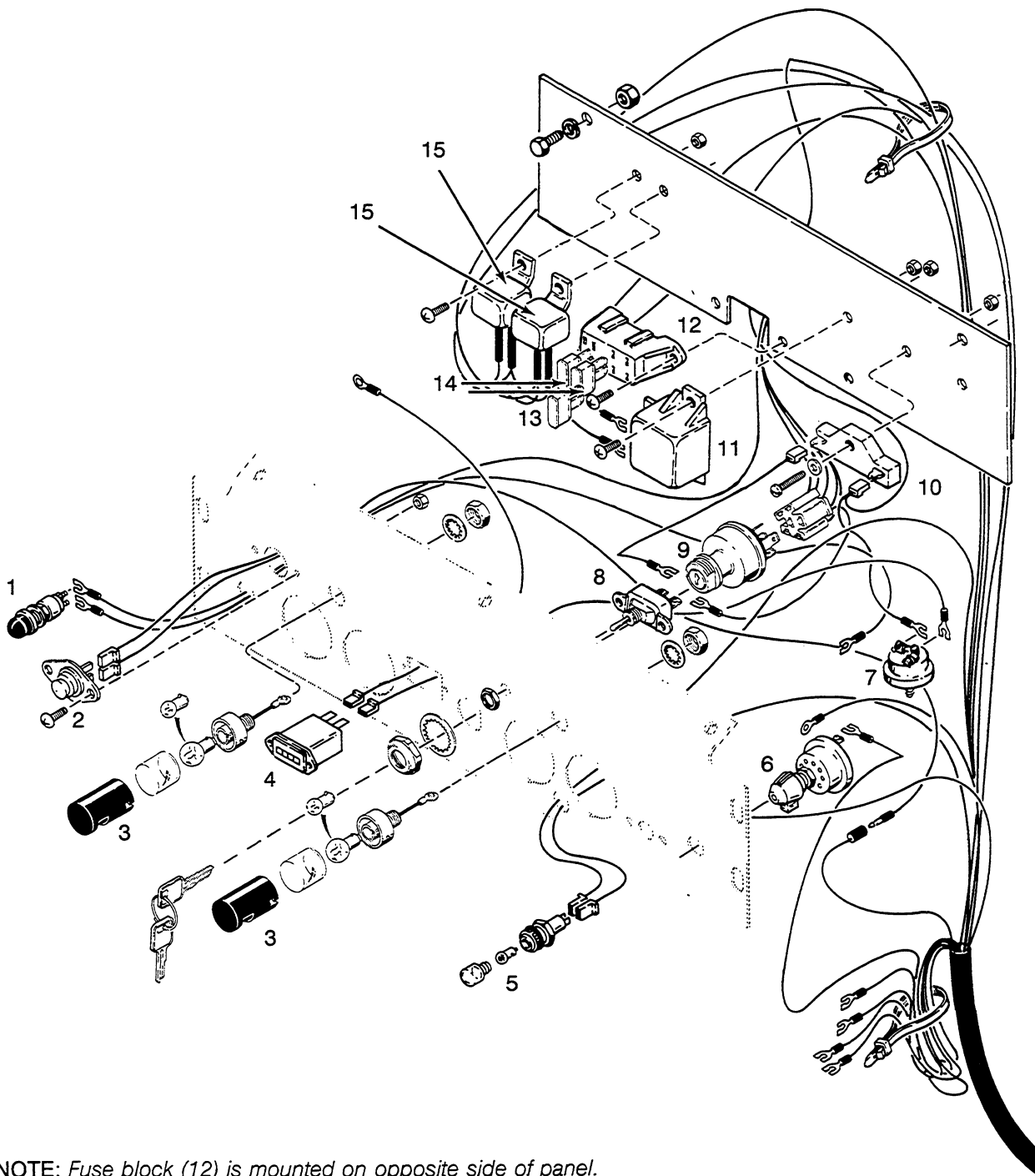

NOTE: Fuse block (12) is mounted on opposite side of panel.

- 1. Alternator Indicator Lamp
- 2. Cold Start Switch
- 3. Panel Lamp
- 4. Hourmeter
- 5. Filter Indicator Lamp

- 6. Lamp Switch
- 7. Engine Oil Pressure Switch
- 8. Toggle Switch
- 9. Key Switch
- 10. 75 Ohm Resistor

- 11. 75 Amp Relay Switch
- 12. Fuse Block
- 13. 30 Amp Fuse
- 14. 10 Amp Fuse
- 15. Brake Relay

B911209J

Indicators and Gauges, Electrical

19. If necessary, use a hammer to loosen the cover.

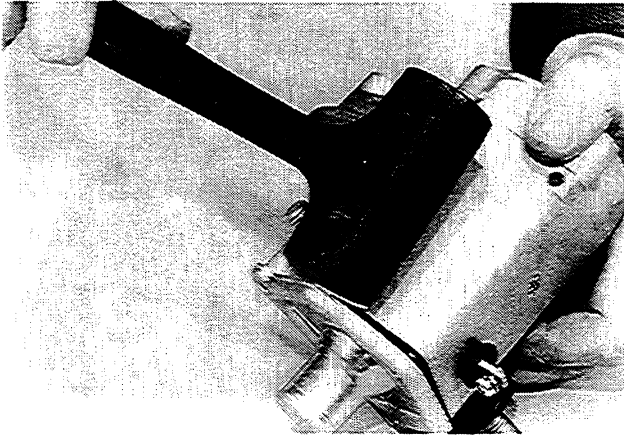

330707

21. Remove the plunger.

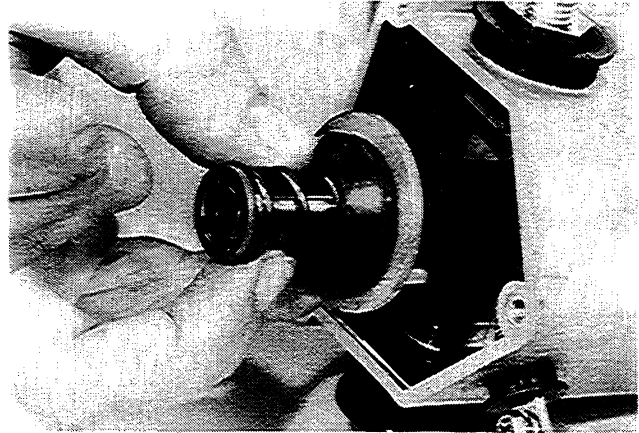

330709

20. Remove the cover.

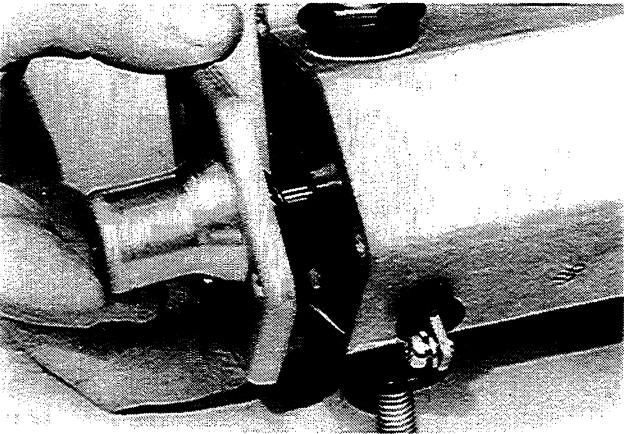

330708

22. If necessary, remove the gasket from the cover.

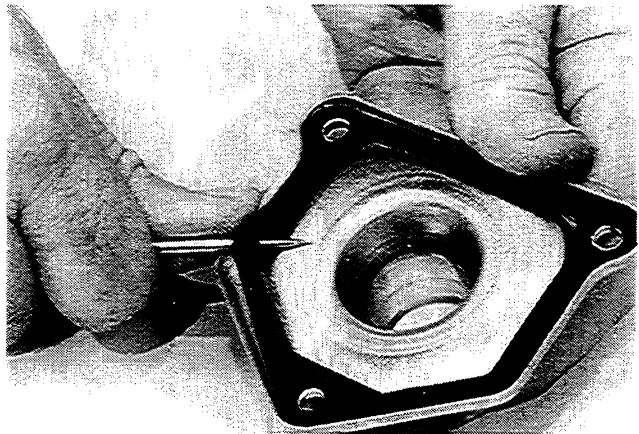

330710

STARTER SOLENOID TEST

This test will check the condition of the pull-in winding and the hold-in winding in the starter solenoid.

The jumper cable connected to the starter mounting flange and the motor terminal must have a common connection at the negative battery post.

Starter Solenoid Test Procedure

1. Remove the rubber boot from the motor terminal. Remove the nut and lock washer from the motor terminal. Then remove the wire from the motor terminal.
2. Connect a jumper cable to the positive battery post of a fully charged 12 volt battery. Connect the other end of the jumper cable to the battery terminal in the starter solenoid housing.

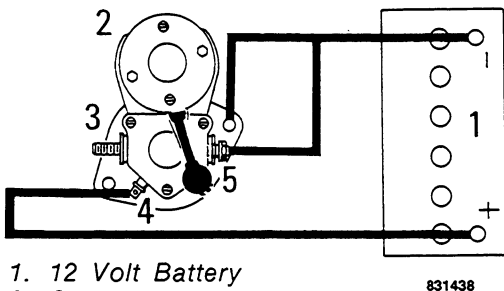

1. 12 Volt Battery
2. Starter
3. Battery Terminal
4. Switch Terminal
5. Motor Terminal

3. Connect a jumper wire to the battery terminal and the switch terminal in the starter solenoid housing. The jumper wire must be made from No. 10 or larger wire.

4. Connect the jumper cable with the common connection to the starter mounting flange and the motor terminal in the starter solenoid housing.

NOTE: Steps 5 and 7 must be done in a maximum of 5 seconds to prevent damage to the pull-in winding and the hold-in winding.

5. Connect the jumper cable with the common connection to the negative battery post. The pinion gear on the starter drive must come all the way out rapidly and with force.

6. If the pinion gear did not come out rapidly and with force, the pull-in winding is damaged. The complete starter solenoid housing assembly must be replaced.

7. Disconnect the jumper cable from the motor terminal in the starter solenoid housing. The pinion gear on the starter drive must not move toward the starter drive housing.

8. If the pinion gear started to move toward the starter drive housing, the hold-in winding is damaged. The complete starter solenoid housing assembly must be replaced.

INSPECTION AND TESTING OF STATOR

STEP 38

Look for burned insulation on the coils of the stator. This is an indication of a short circuit. Install a new stator.

STEP 39

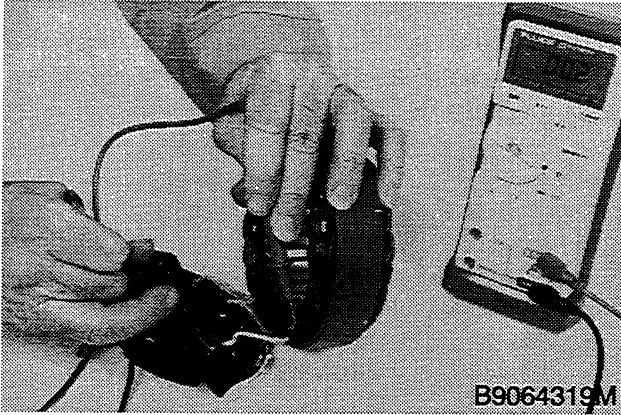

Touch the leads of the ohmmeter to each lead from the stator and the common connection. The readings must be 0.09 to 0.11 ohm. If the readings are not as specified, a new stator must be installed.

STEP 40



Touch the leads of the ohmmeter to each lead from the stator and the frame. If a reading shows continuity, a new stator must be installed.

STEP 41

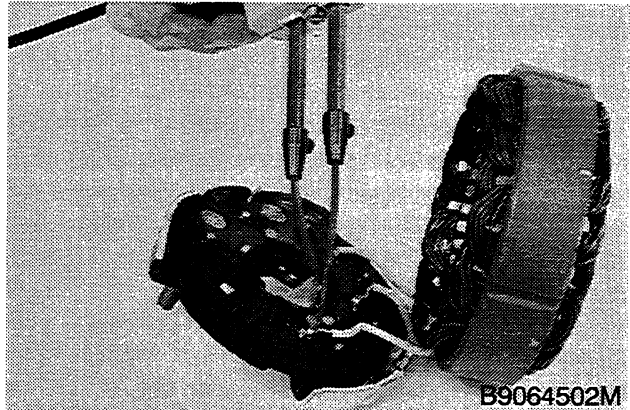

Use a high watt soldering iron and rosin core solder to solder the leads of the stator to the rectifier bridge.

Section 5001

UNDERCARRIAGE FUNDAMENTALS

REVERSE DRIVE SIDE WEAR OF THE SPROCKET AND BUSHINGS

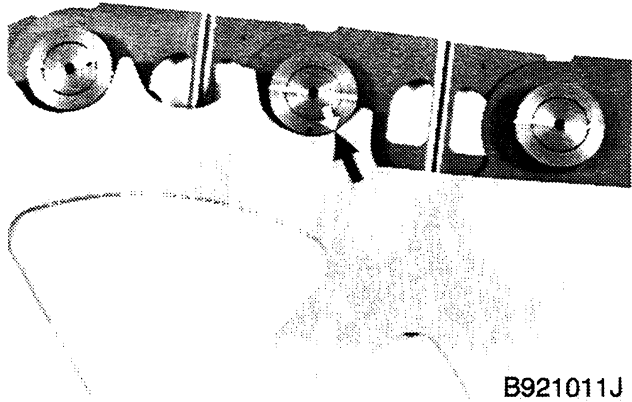

B921011J

- This is the most severe of all bushing and sprocket wear. The sprocket teeth make contact with the bushings at 12 o'clock. Most of the torque required to move the machine is transferred at this point.
- The track chain bushing becomes the hinge point in reverse drive operation.
- Reverse drive must be kept to a minimum. If reverse drive is required, reduce the speed.

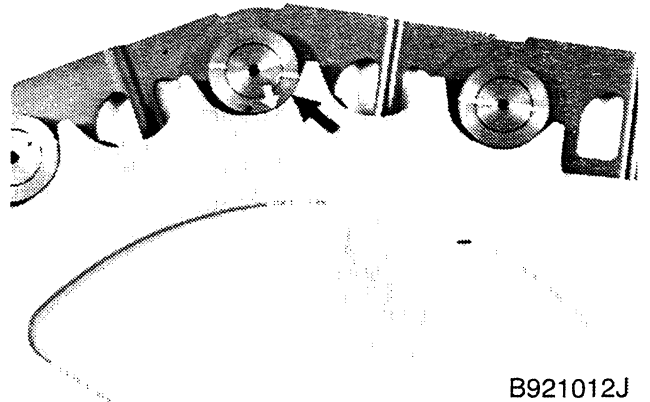

B921012J

- There are three wear/movement points in the REVERSE direction as opposed to one in FORWARD.
 - a. Sprocket scuffing from the bushing
 - b. Bushing scuffing and rotation
 - c. Internal pin and bushing wear

VERTICAL WEAR OF THE BUSHINGS AND SPROCKETS

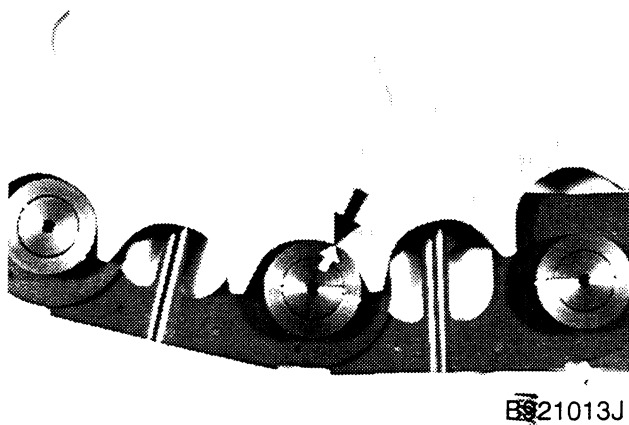

B921013J

- This wear results when the bushing slides back and forth in the sprocket.

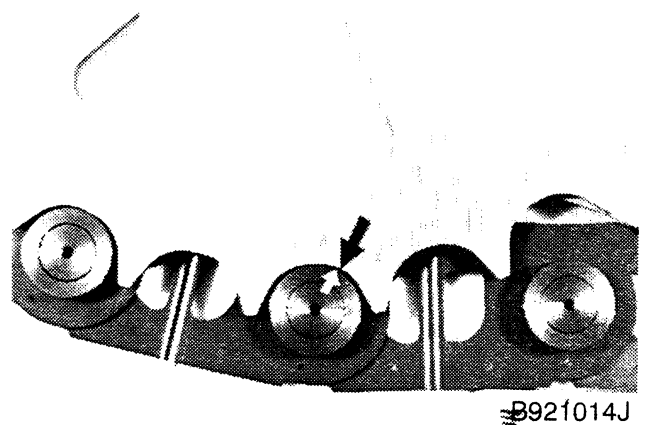

B921014J

- Frequent forward and reverse shifting accelerates this wear.

FACTORS CONTROLLING UNDERCARRIAGE WEAR

INTERMITTENT PACKING - Packing can also occur between some of the sprocket teeth. When this happens, the track is tightened and released rapidly causing the recoil spring to compress and release. A loud "banging" noise will result.

EXTREME REVERSE LOADING - During this operation (loader machine with full loader bucket) the machine is backing up a hill and the top of both track chains are tight compressing the recoil springs. You suddenly drive the machine forward. The loud "banging" noise that you hear can be from one or both recoil springs releasing.

WEAR FACTORS YOU CAN CONTROL

Good operating techniques and a good maintenance program will help you to get the longest life from your undercarriage.

Track Tension

Check the track tension frequently when you operate. When working in mud, snow, and some sandy conditions, check the track tension more often. Material will pack on the undercarriage parts and cause the tracks to become too tight. Always maintain the correct track tension and always clean the undercarriage when you are done for the day. See page 35 for complete information on track tension and track adjustment.



B4036891P

Track Shoes

The shoes must provide adequate traction and flotation but must be no wider than absolutely necessary. Flotation is the ability to stay on the surface of soft ground or mud. Correct flotation occurs when the grousers penetrate fully into the ground without letting the track shoes go below the surface.

Track shoes that are too wide can have a damaging effect on many of the undercarriage components. Because the middle of the track shoe is fastened to the track links, the links act as a fulcrum and must absorb or transmit any leverage or twisting forces that occur as the machine moves over uneven or rocky terrain. All of the other components (sprockets, track rollers, and idlers) resist and restrict the twisting forces of the links. As a result, most of the wear and damage caused by this twisting action affects the links, pins, bushings and track plate mounting hardware. Listed below are some of the effects of wide track shoes.

- Resistance to turning - results in wear on the shoe corners and twists the track chain.
- Bending, cracking or breaking the track shoes, shoe hardware, and links.
- Constant problems with loose shoe hardware that makes the bolt holes larger.
- Increased wear on links, roller flanges, and idler flanges caused by a constant twisting of the track chain.
- Decreased pin and bushing life, or decreased link life due to elongated pin and bushing bores. This is a result of the twisted links.
- Possible loss of lubricant in the Case Lubricated Track pins. This will result in early pin and bushing wear.

Sprocket Wear on the Inside of the Links

The following illustration shows wear caused by the tips of the sprocket teeth on the inside of the link. This occurs due to misalignment between the sprocket and rear roller. Other causes can be a chain that has worn pins and bushings, side hill operation or track shoes that are too wide.

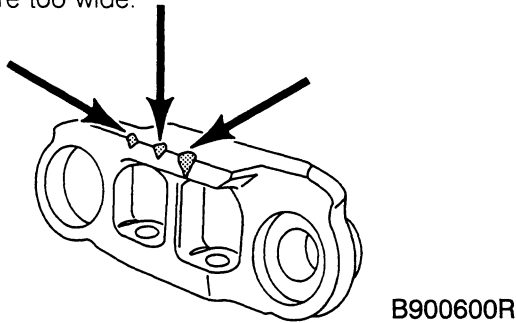

Link Rail Spalling

This condition occurs with repeated high impact loading with the track rollers. Machine speed, weight, tracks that are too tight, or track shoes that are too wide can also cause the problem. If the area of damage is over 25 to 30%, wear life and rebuildability may be reduced.

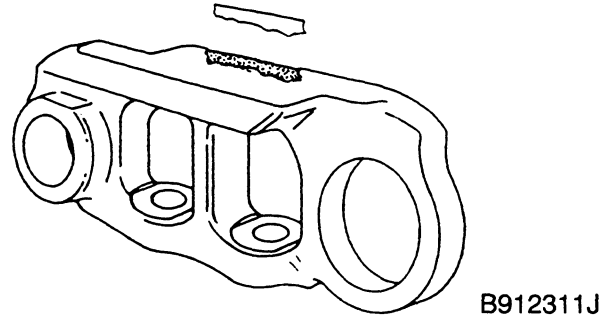

Wear in the Counterbore (Non-Lubricated Track)

This wear is caused by the same condition as was stated under Wear on the Inside Surface of the Link - wear caused by rotating contact with the next link when seal failure occurs. Bushing end wear and lack of link separation occurs. Other kinds of causes can be side hill operation, turning and high impact.

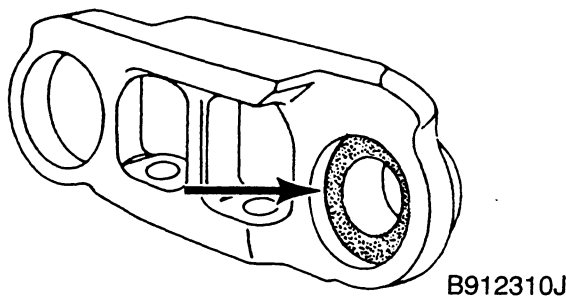

Pin Boss End Wear of the Link

Wear of the pin boss is caused by sliding contact with the track guides/rock guards. This condition is caused by side hill operation or track shoes that are too wide.

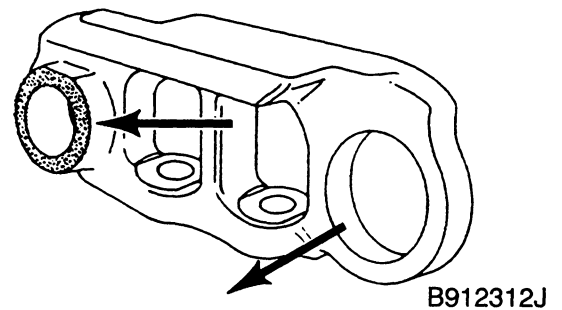

CLICK HERE TO **DOWNLOAD** THE COMPLETE MANUAL

- Thank you very much for reading the preview of the manual.
- You can download the complete manual from: www.heydownloads.com by clicking the link below



- Please note: If there is no response to CLICKING the link, please download this PDF first and then click on it.

CLICK HERE TO **DOWNLOAD** THE COMPLETE MANUAL

Track Link Height

The only wear that can be measured is wear of the rail on the track links. To measure the height of the track links, assemble the rulers in the kit to make a depth gauge. Make sure the areas to be measured are clean. Make the measurement in the area shown in the following illustration. Make sure you hold the ruler 90° to the track shoe. Measure 3 track links 3 to 4 feet (0.9 to 1.2 m) apart. Record the smallest measurement on the Track Component Appraisal Form.

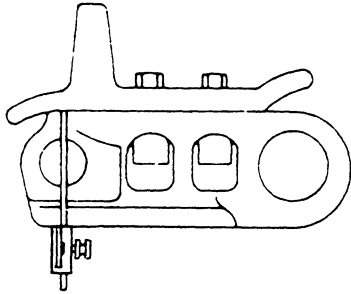

B900596J

Pins and Bushings (Pitch Extension)

To measure the internal bushing and pin wear, measure the track pitch in three places on each track. This measurement is the distance between five track pins. Make sure the measurement is taken at least four track links away from the master pin (non-lubricated track). The master pin has a hole in each end. Tighten the track to remove all slack and measure from the front of one pin to the front of the 5th pin. See the following illustration. Make a record of the measurements on the Track Component Appraisal Form.

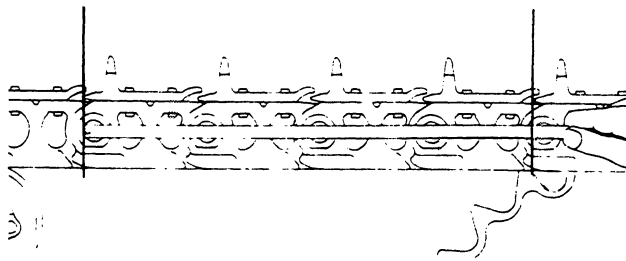

B800707J

IMPORTANT: *The Case lubricated track will have little pitch wear unless the seals are damaged and the lubricant lost in individual joints. The dry joint will feel hot after operation.*

Track Rollers and Carrier Rollers

The only wear that can be measured on these rollers is the treads. Use the large caliper from the kit and measure both treads of each roller. If required, remove the rock guards/track guides. When installing the rock guards/track guides, use Loctite 242 on the threads of the mounting bolts. When the middle track rollers are 40% worn, it is recommended that the track rollers be rotated. Make a record of the roller measurements on the Track Component Appraisal Form.

Make sure that you hold the caliper in the center of the treads as this is the area of most wear. Care must be taken to find the smallest worn diameter. Measure both treads of each roller.

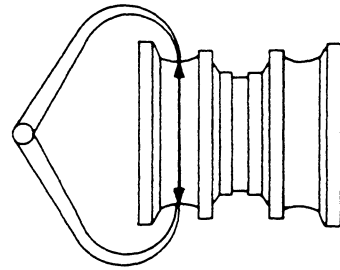

B900602J

Idlers

The only wear that can be measured on the idlers is the treads. Assemble the rulers in the kit to make a depth gauge. See the following illustration. Make sure the treads are clean. Measure the center of the treads as this is the area of greatest wear. Measure both sides of the idler. Make a record of the idler measurements on the Track Component Appraisal Form.

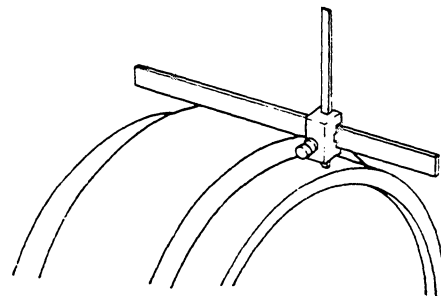

B900608J

SPECIAL TOOL



B4007091S

CAS-1950A Measuring Tool Kit.

WEAR CHART FOR FORWARD AND REVERSE BUSHING WEAR FOR SEALED TRACK WITH 6.29 IN (159.7 mm) PITCH

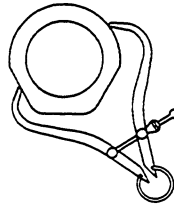

B900594S

| Inch | Percent worn for high impact conditions | Percent worn for low impact conditions | (mm) |
|------|--|---|-------|
| 2.00 | 0 | 0 | 50.80 |
| 1.99 | 10 | 8 | 50.55 |
| 1.98 | 20 | 16 | 50.29 |
| 1.97 | 30 | 24 | 50.04 |
| 1.96 | 40 | 32 | 49.78 |
| 1.95 | 50 | 40 | 49.53 |
| 1.94 | 60 | 48 | 49.28 |
| 1.93 | 70 | 56 | 49.02 |
| 1.92 | 79 | 64 | 48.77 |
| 1.91 | 84 | 72 | 48.51 |
| 1.90 | 89 | 76 | 48.26 |
| 1.89 | 93 | 80 | 48.01 |
| 1.88 | 97 | 83 | 47.75 |
| 1.87 | 100* | 86 | 47.50 |
| 1.86 | 103 | 89 | 47.24 |
| 1.85 | 106 | 92 | 46.99 |
| 1.84 | 108 | 94 | 46.74 |
| 1.83 | 110 | 96 | 46.48 |
| 1.82 | 112 | 98 | 46.23 |
| 1.81 | 114 | 100* | 45.97 |
| 1.80 | 116 | 102 | 45.72 |
| 1.79 | 118 | 104 | 45.47 |
| 1.78 | 120 | 106 | 45.21 |
| 1.77 | 122 | 107 | 44.96 |
| 1.76 | 124 | 108 | 44.70 |

*Turn pins and bushings before this point.
It is recommended pins and bushings be
replaced if wear is beyond this point.

TRACK COMPONENT APPRAISAL FORM

REPORTED BY _____ DATE _____

DEALER _____

OWNER _____

OWNER ADDRESS _____

LOCATION OF UNIT _____

UNIT MODEL _____ S/N _____ DATE MACHINE DELIVERED _____

HOURMETER _____ ACTUAL UNIT HOURS _____ TRACK COMPONENT HOURS _____

MOUNTED EQUIPMENT: FRONT _____ REAR _____

TRACK SHOES: WIDTH _____ OPEN CLOSED 1 BAR HVY. DUTY 2 BAR 3 BAR

CAST SELF-CLEANING OTHER _____

DOES UNIT HAVE FRONT AND REAR TRACK GUIDES _____ CENTER ROCKGUARDS _____

TRACK CHAIN: SEALED TRACK CASE LUBRICATED TRACK DOES UNIT HAVE OTHER THAN CASE TRACK

COMPONENTS _____ ITEMS _____

TRACK DEFLECTION _____ LH SIDE _____ RH SIDE _____

MEASUREMENTS RECORDED IN U.S. STANDARD METRIC

| | NEW DIMENSION | PRESENT DIMENSION | | RECOM- MENDED WEAR LIMIT | % WEAR REMAINING | |
|-----------------------|---------------|-------------------|-------|--------------------------|------------------|-------|
| | | LEFT | RIGHT | | LEFT | RIGHT |
| GROUSERS HGT. | | | | | | |
| LINK HEIGHT | | | | | | |
| IDLER FLG. HEIGHT | | | | | | |
| TRACK ROLLER | | | | | | |
| RAIL DIA. | FRONT | | | | | |
| | REAR | | | | | |
| CARRIER ROLLER | | | | | | |
| RAIL DIA. | FRONT | | | | | |
| | REAR | | | | | |

| | MATERIAL CONTENT | | | |
|---|--------------------------|--------------------------|--------------------------|--------------------------|
| | 25% | 50% | 75% | 100% |
| SAND | <input type="checkbox"/> | <input type="checkbox"/> | <input type="checkbox"/> | <input type="checkbox"/> |
| ROCK | <input type="checkbox"/> | <input type="checkbox"/> | <input type="checkbox"/> | <input type="checkbox"/> |
| CLAY | <input type="checkbox"/> | <input type="checkbox"/> | <input type="checkbox"/> | <input type="checkbox"/> |
| LOAM | <input type="checkbox"/> | <input type="checkbox"/> | <input type="checkbox"/> | <input type="checkbox"/> |
| | <input type="checkbox"/> | <input type="checkbox"/> | <input type="checkbox"/> | <input type="checkbox"/> |
| WET <input type="checkbox"/> DRY <input type="checkbox"/> | | | | |

| | APPLICATION TIME | | | |
|------|--------------------------|--------------------------|--------------------------|--------------------------|
| | 25% | 50% | 75% | 100% |
| DOZE | <input type="checkbox"/> | <input type="checkbox"/> | <input type="checkbox"/> | <input type="checkbox"/> |
| RIP | <input type="checkbox"/> | <input type="checkbox"/> | <input type="checkbox"/> | <input type="checkbox"/> |
| PUSH | <input type="checkbox"/> | <input type="checkbox"/> | <input type="checkbox"/> | <input type="checkbox"/> |
| DRAW | <input type="checkbox"/> | <input type="checkbox"/> | <input type="checkbox"/> | <input type="checkbox"/> |
| | <input type="checkbox"/> | <input type="checkbox"/> | <input type="checkbox"/> | <input type="checkbox"/> |

BUSHING O.D. WEAR

| | NEW DIMENSION | PRESENT DIMENSION | | | RECOMMENDED WEAR LIMIT | % REMAINING |
|---------------|---------------|-------------------|-------|------|------------------------|-------------|
| | | FWD | VERT. | REV. | | |
| LH BUSHING #1 | | | | | | |
| LH BUSHING #2 | | | | | | |
| LH BUSHING #3 | | | | | | |
| AVERAGE | | | | | | |
| RH BUSHING #1 | | | | | | |
| RH BUSHING #2 | | | | | | |
| RH BUSHING #3 | | | | | | |
| AVERAGE | | | | | | |

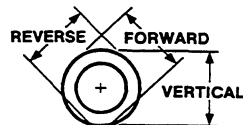
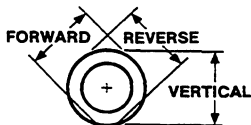

RECOMMENDATIONS _____

CHAIN PITCH ACROSS 5 PINS

| | | | |
|----------|--|----------|--|
| LH CHAIN | | RH CHAIN | |
| LH CHAIN | | RH CHAIN | |
| LH CHAIN | | RH CHAIN | |
| AVERAGE | | AVERAGE | |

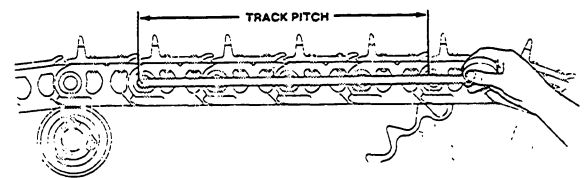

7. To loosen the track, use a socket wrench and loosen the large adapter two turns. Let the grease flow out of the large adapter until the track deflection is correct.

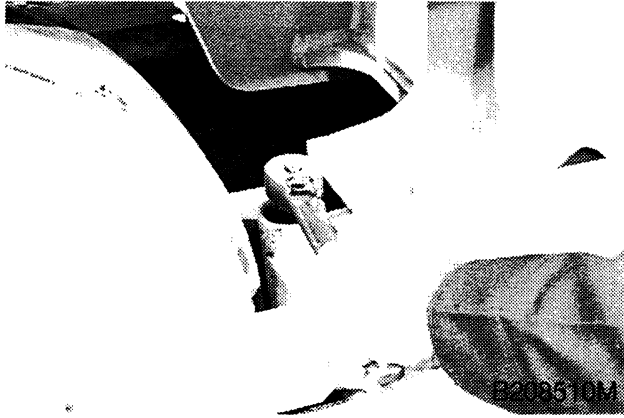

8. When the deflection is correct, tighten the valve to 45 to 55 pound-feet (61 to 74 Nm). Install the plug.

- 10 Actuate the other ram to press the pin and bushing out of the other link

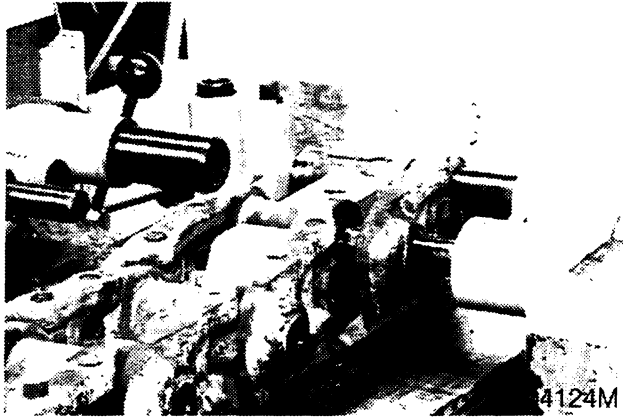

- 11 Retract the ram and remove the link from the driver and the pin from the bushing
- 12 Repeat steps 7 through 11 until the track chain is disassembled
- 13 Remove the spacers from the pins and seals
- 14 Remove the seals from the links
- 15 Clean all parts in cleaning solvent
- 16 Use a wire brush and clean the seal bore in each link
- 17 Use a wire brush and clean the reservoir in each pin
- 18 See Usage Guide for Pins and Bushings and Seals

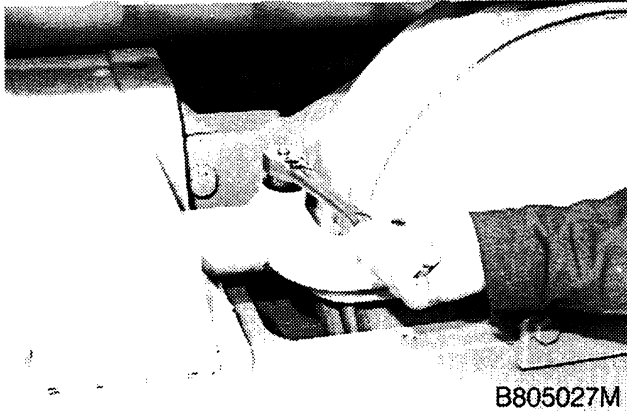
STEP 7

B805027M

Loosen the large adapter in the track adjuster two turns. Let the grease flow out of the track adjuster to release the tension on the track.

STEP 8

Prepare the portable hydraulic press according to the instructions of the manufacturer.

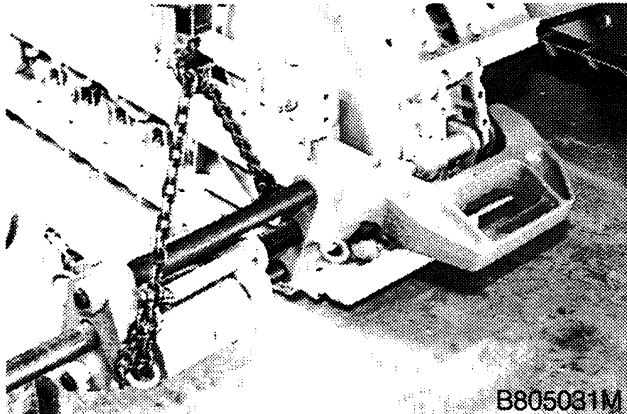
STEP 9

B805031M

Connect the portable hydraulic press to acceptable lifting equipment. Put the portable hydraulic press in position on the master pin. The master pin must be pushed to the inside of the track when the master pin is removed.

NOTE: When removing the master pin, push the pin out 2/3 of its length and check the pin for a groove caused by wear. If the pin does not have a groove, remove it all the way out of the track assembly. If the pin has a groove, remove the portable hydraulic press and cut the pin using a cutting torch. Hit the short end of the pin with a hammer until it is inside the bushing.

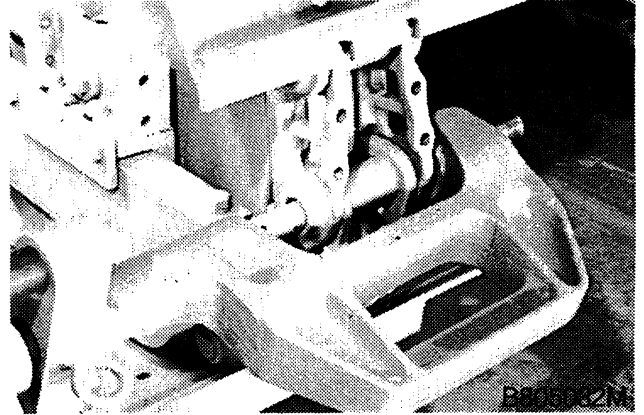
STEP 10

B805032M

Put the push pin in position on the master pin. Use the portable hydraulic press to push the master pin out of the chain. See the note on this page.

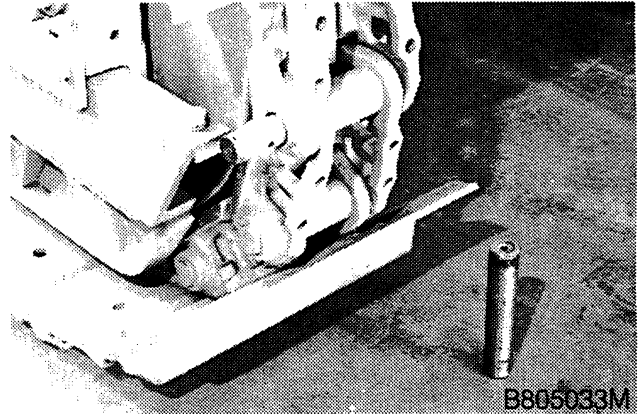
STEP 11

B805033M

Remove the portable hydraulic press from the track. Remove the push pin from the chain.

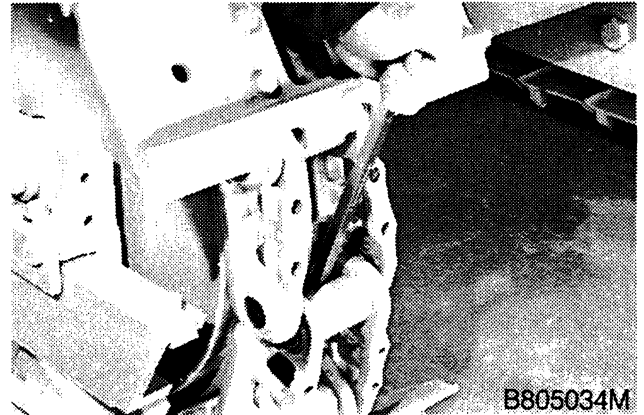
STEP 12

B805034M

Use a prybar to separate the chain links.

Section 5507

RUBBER TRACK

IDLER

Removal

1. See Section 5506. Do steps 1 through 16 under Track Removal.
2. Lift the front of the machine until the idler is clear of the track.
3. Put blocks under the machine to hold the machine in position.
4. Remove the cap screws and lock washers that hold the track adjuster yoke to the mounting brackets.
5. Remove any shims that are installed between the mounting brackets and track adjuster yoke. Keep the shims for installation.
6. Remove the cap screws at the front of the track frame.
7. Remove the cap screws, guide plates, and shims from each side of the mounting brackets.
8. Connect a chain hoist to the mounting brackets. Use the cap screws for the guide plates to hold the chain hoist to the mounting brackets.
9. Use the chain hoist to hold the weight of the idler during removal. Remove the idler from the track frame by sliding the idler to the front of the machine.

Installation

1. Check the wear plates on both sides of the track frame. If the wear plates are worn, install new wear plates.
2. Connect a chain hoist to the mounting brackets. Use the cap screws for the guide plates to hold the chain hoist to the idler mounting brackets.
3. Use the chain hoist to help install the idler. Slide the idler onto the track frame. Make sure the hole for putting oil in the idler is away from the machine.
4. Disconnect the chain hoist from the mounting brackets.
5. Install the cap screws for the wear plates at the front of the track frame.
6. Install the same number of shim(s) that were removed between the track adjuster yoke and the mounting brackets. Install the lock washers and cap screws.
7. See Parallel Alignment under Idler Adjustments in this section.
8. Check the clearance between the wear plates and the mounting brackets. The clearance is to be as little as possible. The clearance is adjusted by adding or removing shim(s). See Vertical Alignment under Idler Adjustments in this section.
9. Put the guide plates in position and install the shims and cap screws. See Center Alignment under Idler Adjustments in this section.
10. See Section 5506 for the installation of the track.

IDLER ADJUSTMENTS

To get maximum idler and track life the idler must be in the correct position in the track frame. There are three adjustments for the idler that must be done. The adjustments are: parallel alignment, vertical alignment and centering alignment. It is recommended that all three adjustments be done when it is necessary to do any single adjustment.

Parallel Alignment

1. Measure the distance from the center of the idler shaft to the center of the cap screws that hold the track frame to the front crossmember. Make a record of this measurement.
2. Repeat step 1 for the other side of the idler.
3. The two measurements must be equal within 1/16 inch (1.6 mm). See step 4 if adjustment is needed.

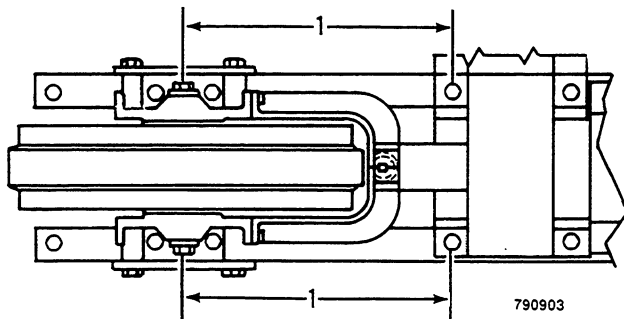

1. BOTH MEASUREMENTS MUST BE EQUAL OR HAVE NO MORE THAN 1/16 INCH (1.6 mm) DIFFERENCE.

4. Adjust the parallel alignment of the idler as follows:
 - a. Loosen the cap screws that hold the track adjuster yoke to the mounting brackets.
 - b. Use a prybar to move the idler away from the track adjuster yoke.

- c. Remove the cap screws from one side of the yoke. Be careful not to drop any shim(s) that may be between the track adjuster yoke and mounting bracket.

- d. Add or remove shims as required to put the idler in the correct position.

- e. Install the cap screws and shims. Do not tighten the cap screws.

- f. Repeat steps c, d, and e for the other side.

- g. Tighten the cap screws.

5. Repeat steps 1, 2, 3, and 4 as required.

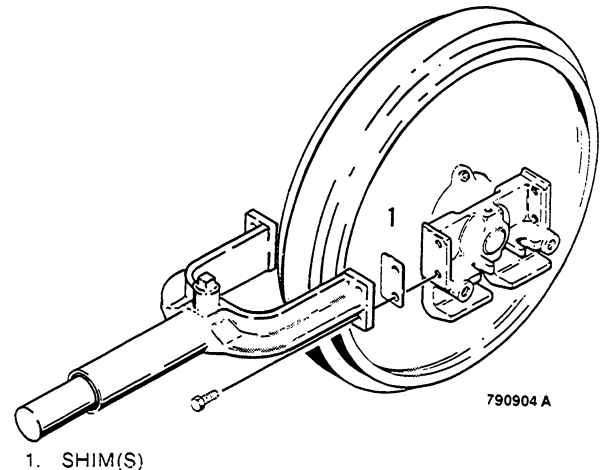

1. SHIM(S)

Vertical Alignment

1. Put a square on the track frame next to the idler.
2. Hold the square even with the inside edge of the track frame.
3. Measure the distance from the idler to the square. The measurement must be taken at the top of the square. Make a record of the measurement.
4. Repeat steps 1, 2, and 3 for the other side of the idler.

Section

5509

SPROCKET

DISASSEMBLY

STEP 1

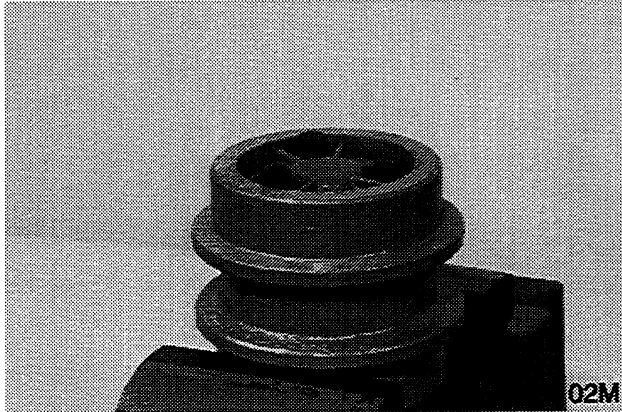

Loosen and remove the cap screws.

STEP 4

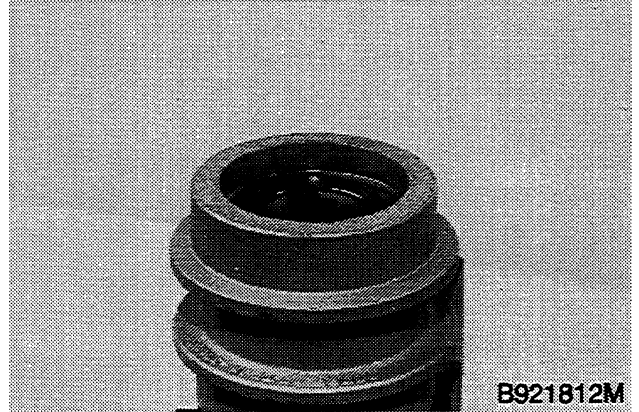

Loosen but do not remove the cap screws that hold the retainer.

STEP 2

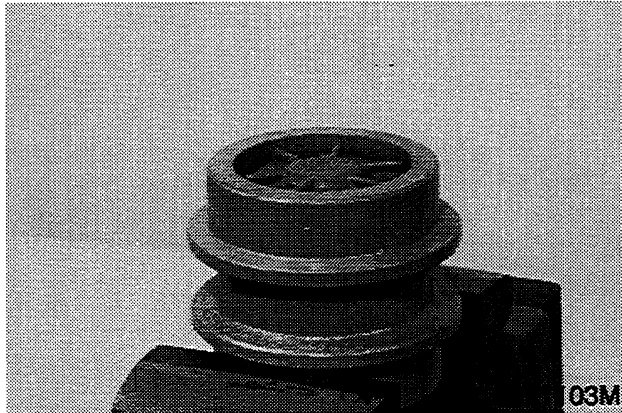

Remove the end cap.

STEP 5

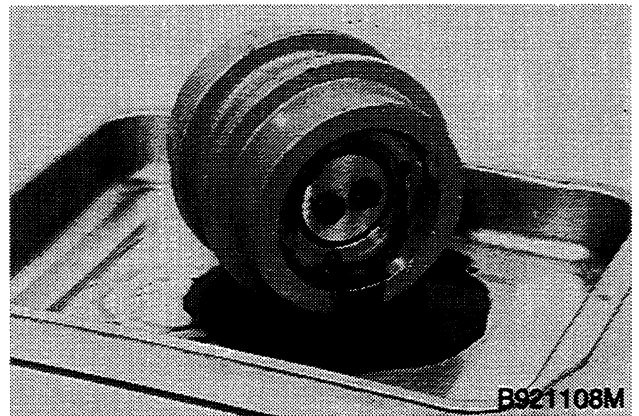

Drain the lubricant.

STEP 3

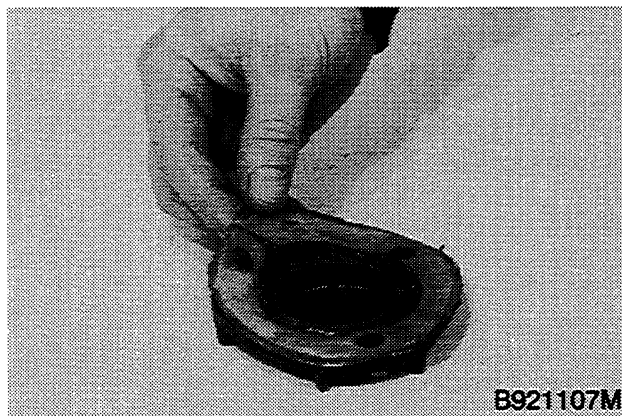

Remove the gasket.

STEP 6

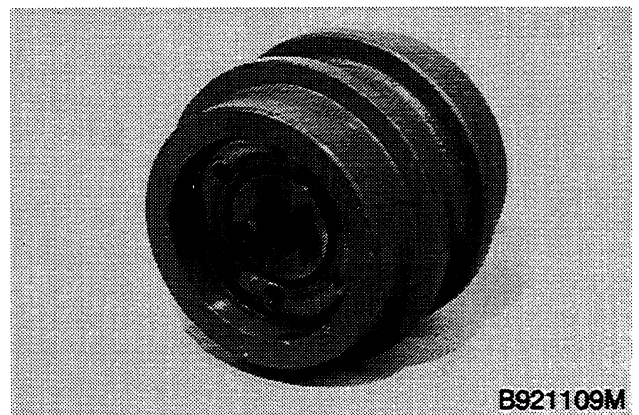

Remove the cap screws.

Section 5511

TRACK ROLLER

STEP 30

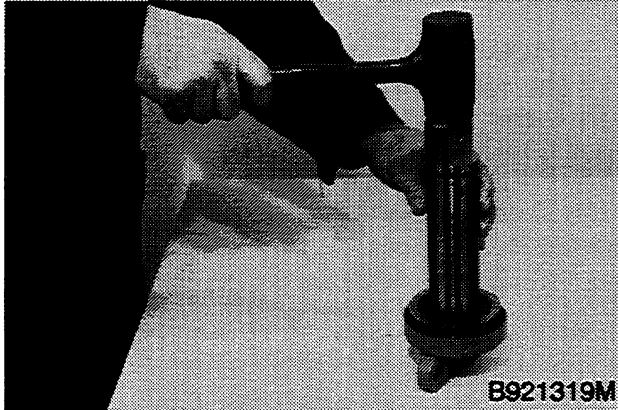

Align the end of the shaft with the O-ring with the end cap and drive the shaft into the end cap.

STEP 33

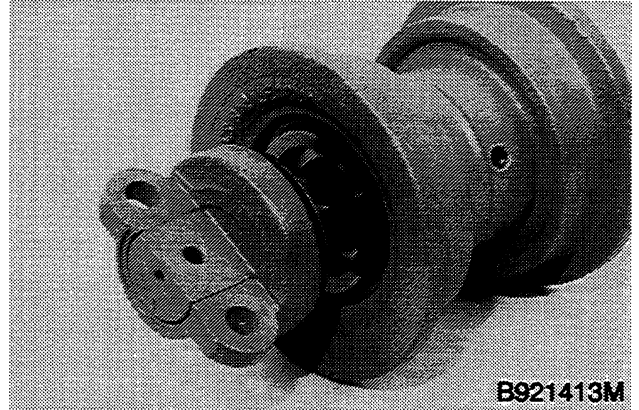

Install the shaft.

STEP 31

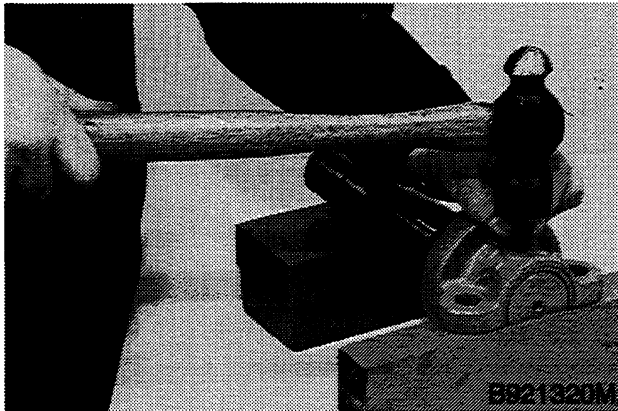

Drive a roll pin into the end cap and shaft.

STEP 34

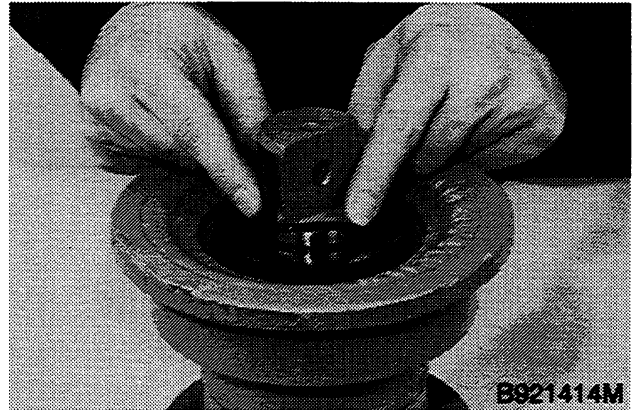

Install the other O-ring.

STEP 32

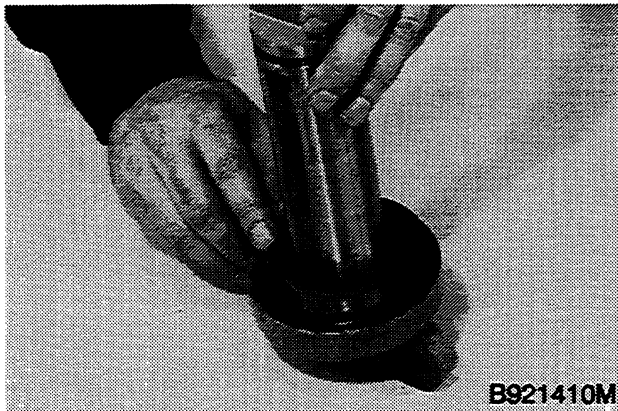

Apply a small amount of oil to the sealing face.

STEP 35



Lubricate the bore of the end cap and the O-ring with oil.

Problem: Loss of Power to One Track

Heat the oil to operating temperature and check the setting of the pressure regulator valve. This pressure must be known to learn the condition of the high or low clutch.

Check the pressure for the high or low clutch. Is the pressure as specified on page 3? NO →

Loss of pressure can be caused by bad seals in the clutch, bad sealing rings on the track speed shaft, a worn bore in the retainer at the front of the track speed shaft, leakage in the modulator valve, or leakage in the transmission control valve.



Check the parts in the modulator valve for wear and damage.



To find whether the problem is in the transmission or the transmission control valve, disconnect the tube for the high or low clutch at the transmission control valve. Install a steel cap on the fitting and check the pressure again. If the pressure is as specified on page 3, the problem is in the transmission. Repair as required.

YES



Check the clutch cutout linkage. See Section 9000 for adjustment procedure. Is there still a problem?

YES



Loss of power can also be caused by worn friction discs in the clutches. Disassemble the transmission and repair as necessary.

NO

→ Troubleshooting complete.

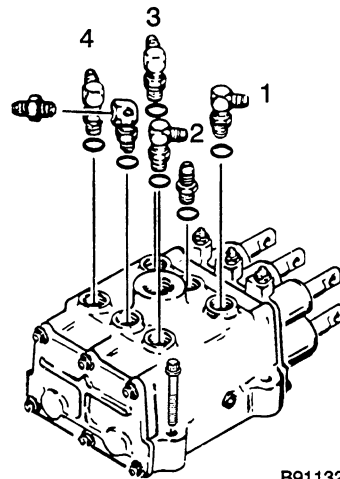

B911324J

1. Right High Clutch
2. Right Low Clutch

3. Left High Clutch
4. Left Low Clutch

THIS PAGE IS INTENTIONALLY LEFT BLANK

STEP 24

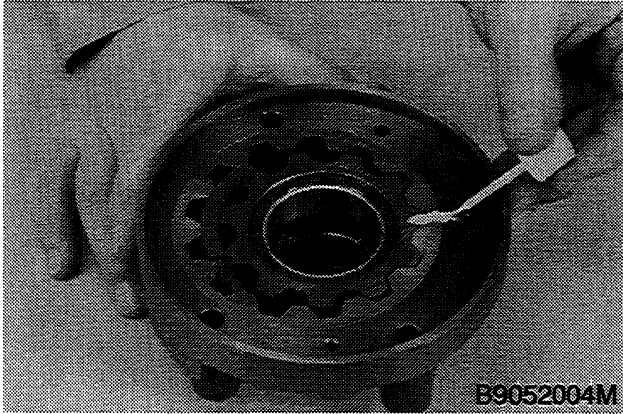

Make a mark on the drive gear, driven gear and body.

STEP 25

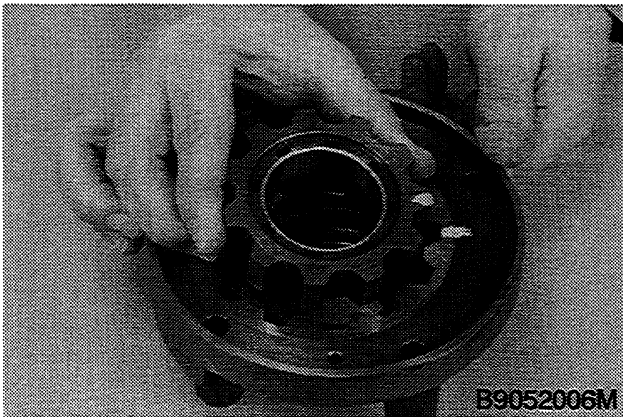

Remove the drive gear.

STEP 26

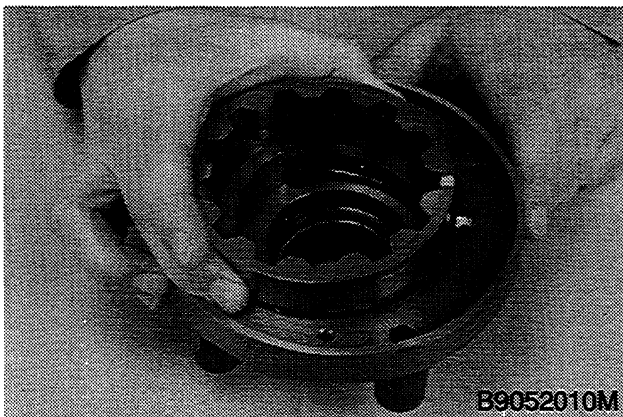

Remove the driven gear.

STEP 27



Remove and discard the seal from the body.

STEP 28

If necessary, remove the bushings from charging pump body.

Inspection

1. Clean all the parts in cleaning solvent. Use compressed air to dry the parts.
2. Only the seal and two bushings are available separately as service parts. If there is damage to any other part of the charging pump, you must install a new assembly.
3. Check the drive gear and the driven gear for wear and damage.
4. Check the body and stator support for pitting, scoring, cracks and wear.

NOTE: *There is only a small amount of clearance between the parts of the charging pump. It is possible for the parts to look good but still be worn enough for the charging pump to be replaced. If troubleshooting shows that there is not enough flow from the charging pump, install a new charging pump.*

TABLE OF CONTENTS

REMOVAL.....2
INSTALLATION.....2
DISASSEMBLY.....4
INSPECTION.....4
ASSEMBLY.....4

REMOVAL

1. Park the machine on a level surface and stop the engine.
2. Remove the seat and seat plate.
3. Put the master disconnect switch in the OFF position. Remove the batteries.
4. Remove the rear cover.
5. Disconnect the linkage from the spools in the transmission control valve.
6. Disconnect the tubes from the fittings in the transmission control valve.
7. Remove the Ferry head screws from the transmission control valve.
8. Remove the transmission control valve.

INSTALLATION

Install the transmission control valve by doing the reverse of removal. Clean the mounting surfaces of the transmission and transmission control valve. Install a new gasket. Tighten the Ferry head screws to 420 to 480 pound-inches (47 to 54 Nm).

After installation, move the transmission control levers to check the spring force on the spool detents. Loosen the lock nuts and turn the adjusting screws for the detents as necessary so that the transmission control levers move smoothly and stop in the detent positions.

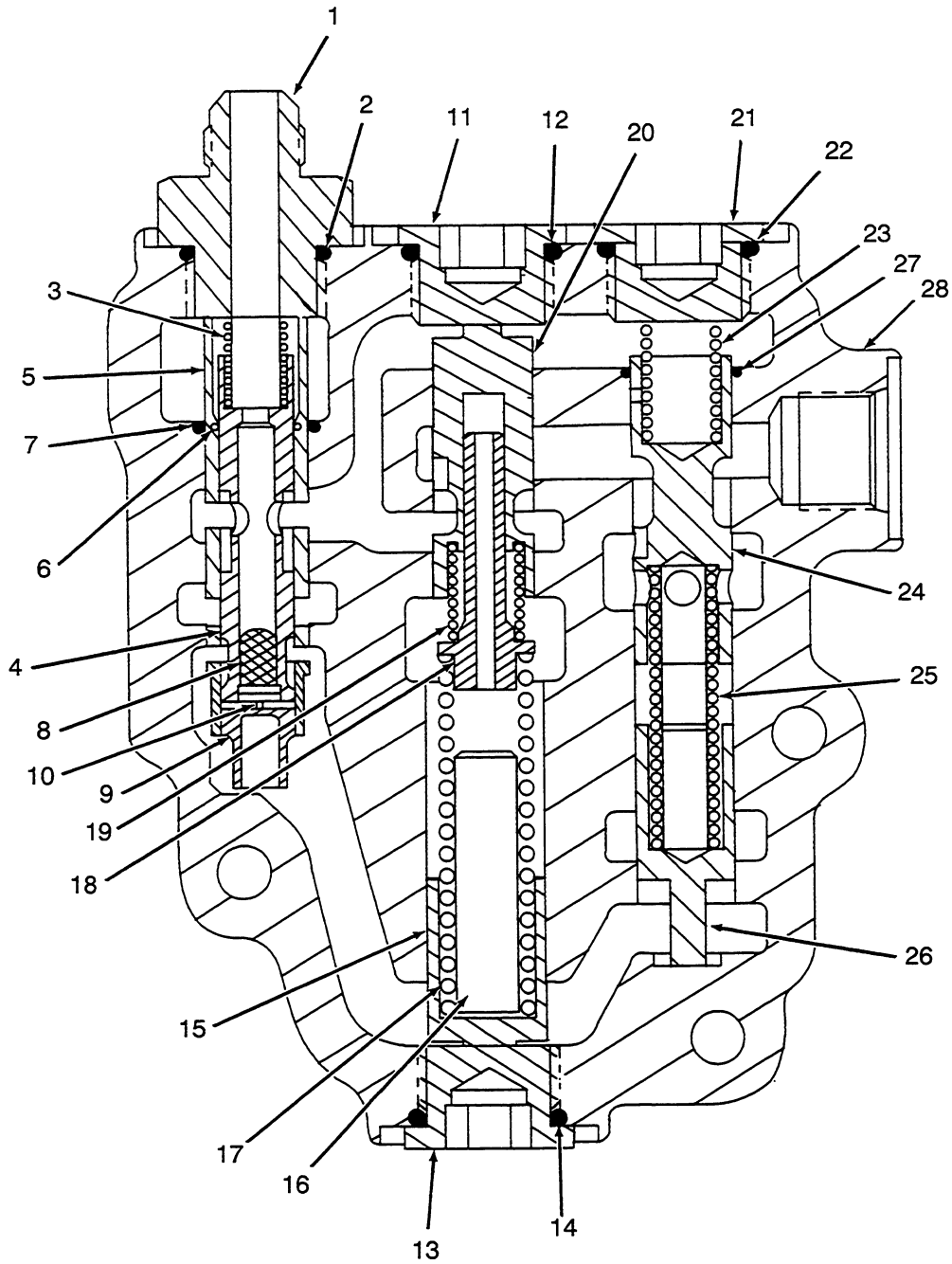

B911174J

- | | | | |
|----------------|--------------------------------|---------------------|-----------------|
| 1. Fitting | 8. Screen | 15. Piston | 22. O-ring |
| 2. O-ring | 9. Retainer | 16. Pin | 23. Spring |
| 3. Spring | 10. Orifice (Part of Retainer) | 17. Spring | 24. Track Spool |
| 4. Flow Spool | 11. Plug | 18. Spring Guide | 25. Spring |
| 5. Flow Sleeve | 12. O-ring | 19. Spring | 26. Poppet |
| 6. Snap Ring | 13. Plug | 20. Modulator Spool | 27. Snap Ring |
| 7. Snap Ring | 14. O-ring | 21. Plug | 28. Body |

STEP 13

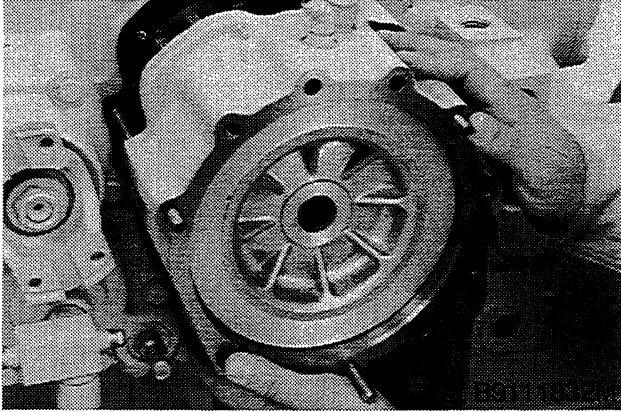

Remove the brake housing.

STEP 16

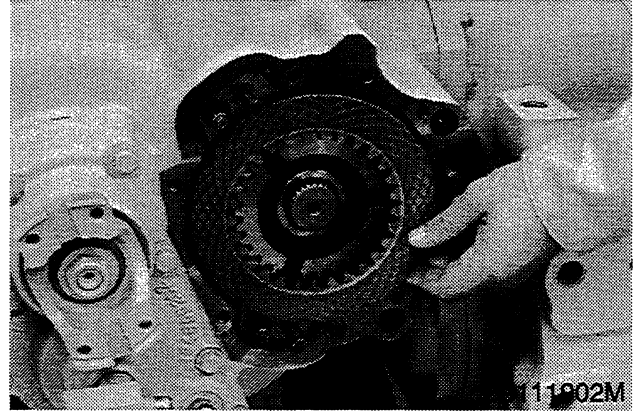

Remove the friction disc.

STEP 14

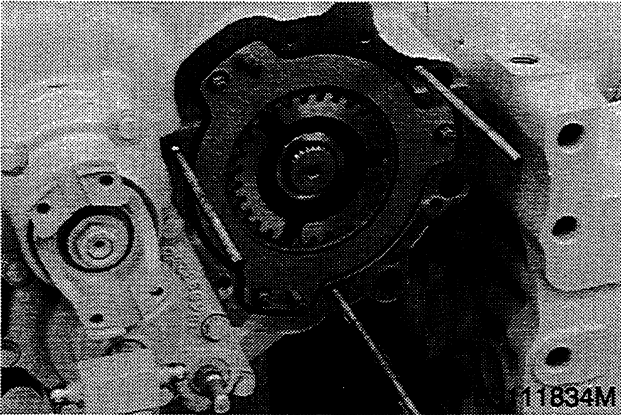

Remove the threaded rods.

STEP 17

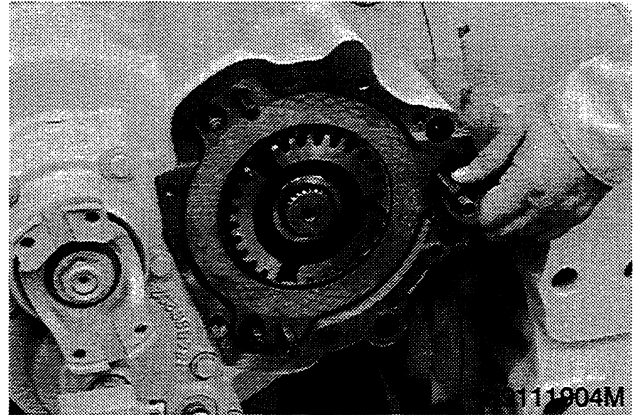

Remove the sleeve and snap rings from each pin.

STEP 15

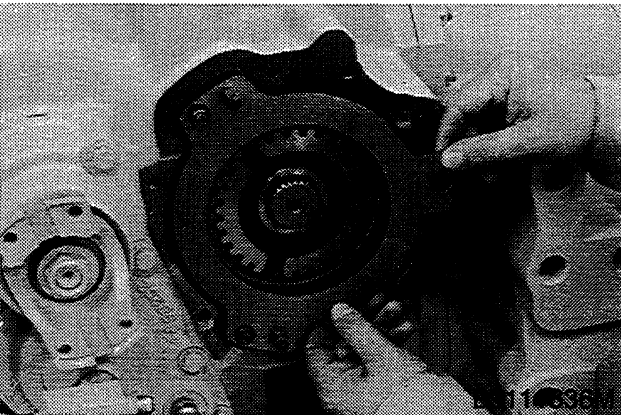

Remove the metal disc.

STEP 18

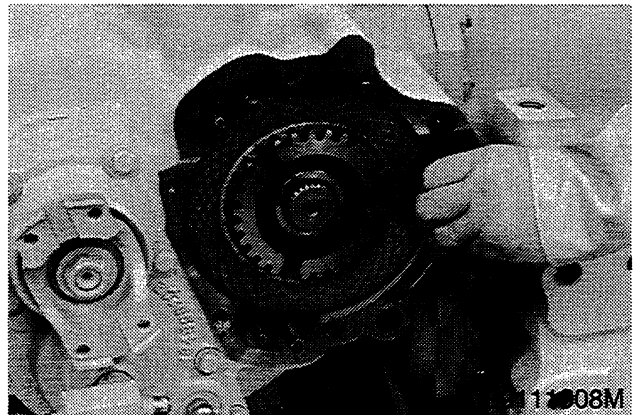

Remove the remainder of the metal and friction discs.

STEP 58

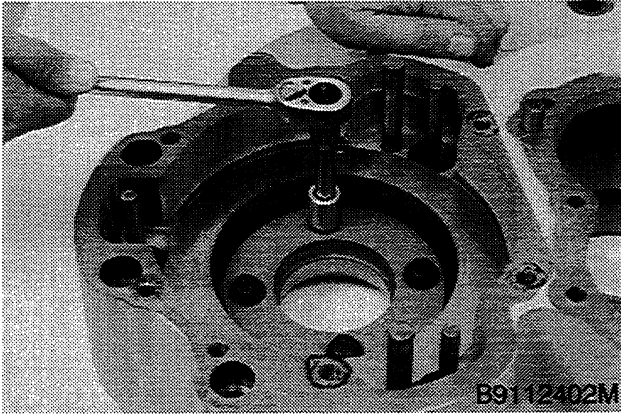

Remove the retainer from the front cover.

STEP 59

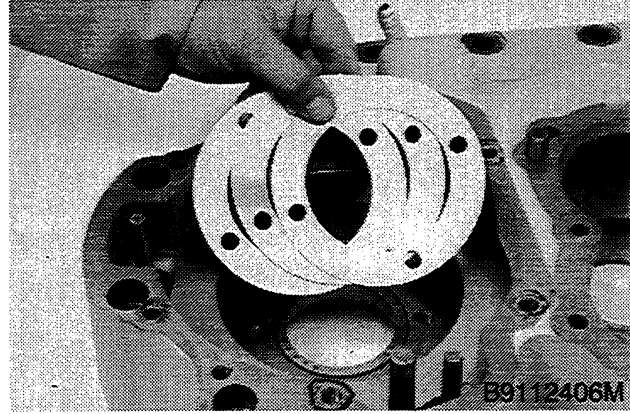

Remove the shims.

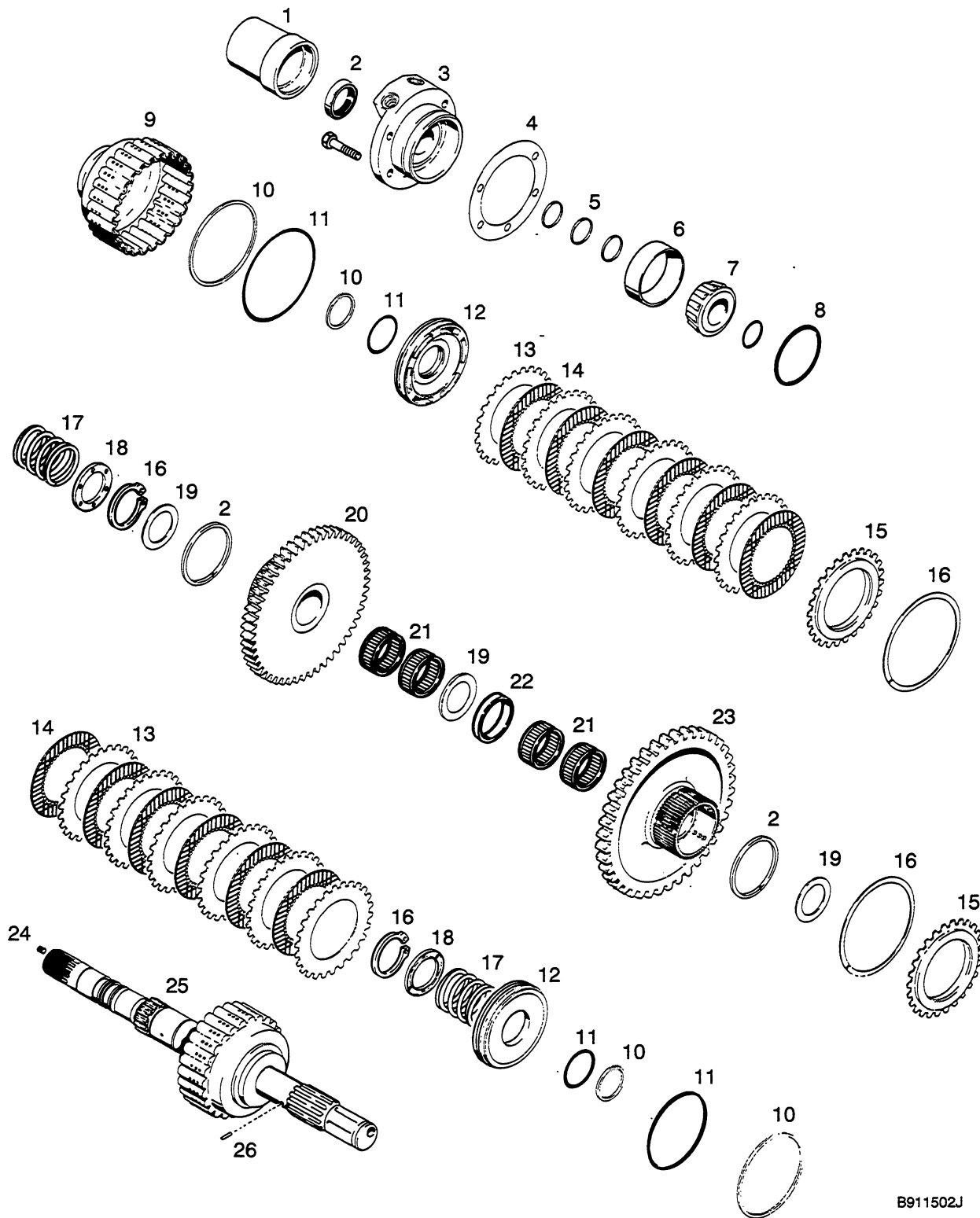

B911502J

- | | | | |
|----------------|-----------------------|--------------------|--------------------------|
| 1. Cover | 8. O-ring | 15. Pressure Plate | 21. Needle Bearings |
| 2. Seal | 9. Clutch Housing | 16. Snap Ring | 22. Thrust Bearing |
| 3. Retainer | 10. Piston Seal | 17. Spring | 23. Reverse Gear |
| 4. Shim | 11. Backup Ring | 18. Spring Seat | 24. Plug. Do not remove. |
| 5. Seal Ring | 12. Piston | 19. Thrust Washer | 25. Main Shaft |
| 6. Bearing Cup | 13. Metal Disc (6) | 20. Forward Gear | 26. Pin. Do Not Remove |
| 7. Bearing | 14. Friction Disc (6) | | |

Main Shaft

STEP 142

Repeat steps 138 through 141 for the other piston.

STEP 143

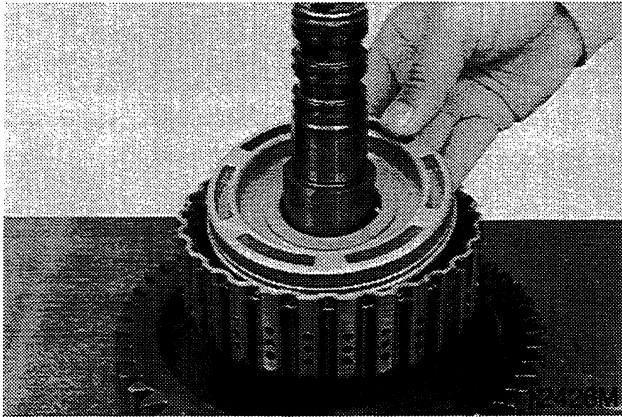

Lubricate the piston seals with lubriplate grease. Install the piston.

STEP 144

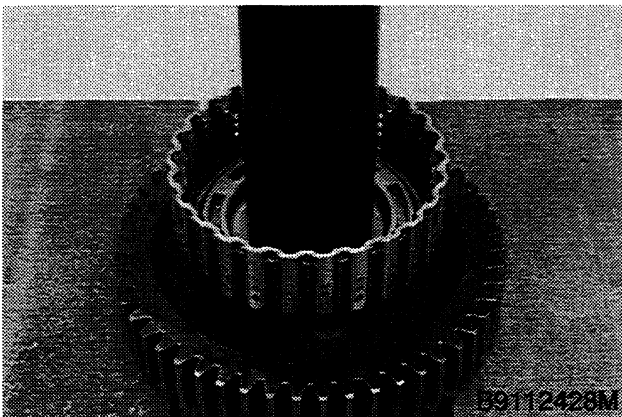

Press the piston into the clutch housing.

STEP 145

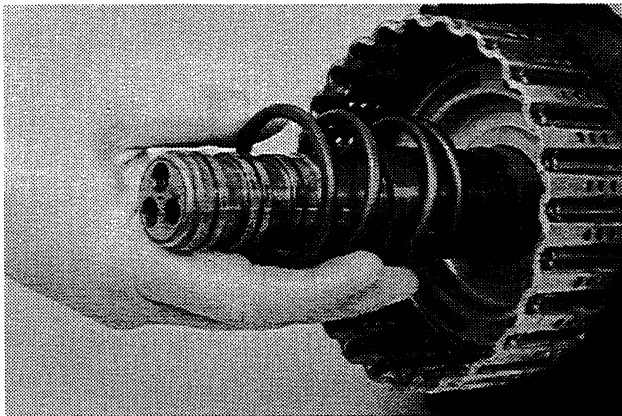

Install the spring.

STEP 146

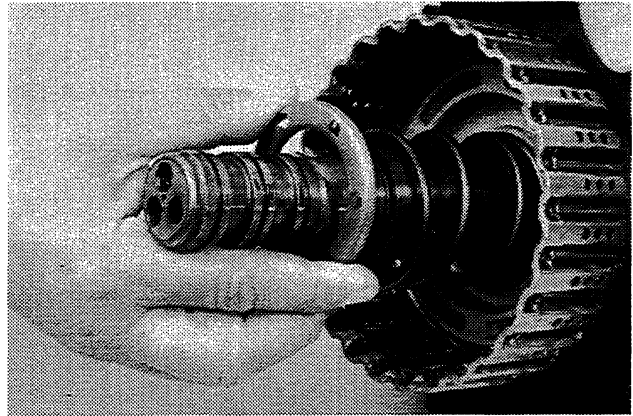

Install the spring seat.

STEP 147

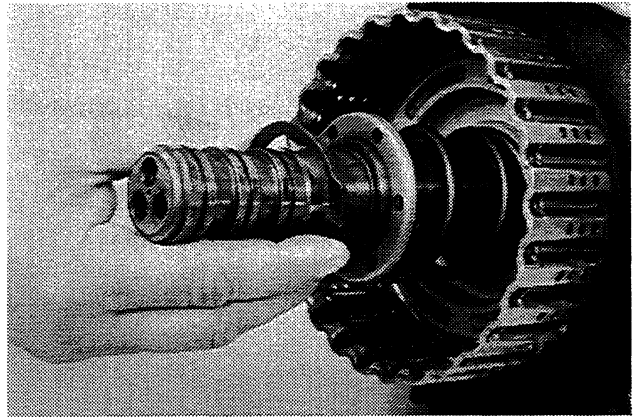

Put the snap ring on the shaft, the sharp edge of the snap ring must be toward the end of the shaft.

STEP 148

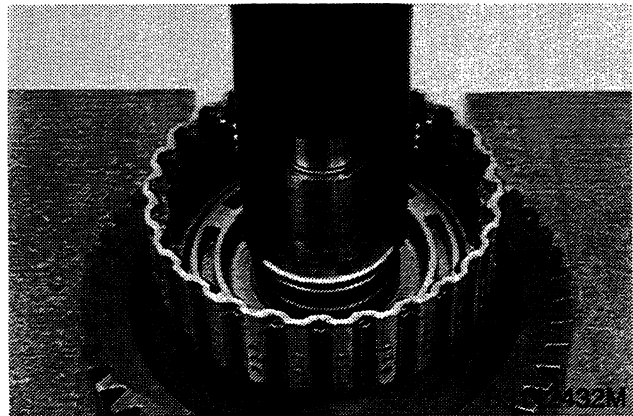

Use CAS-1992 to compress the spring. Install the snap ring in the groove.

STEP 198

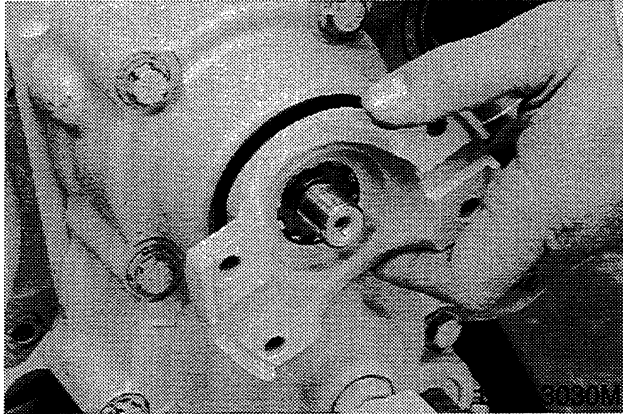

Install the yoke.

STEP 199

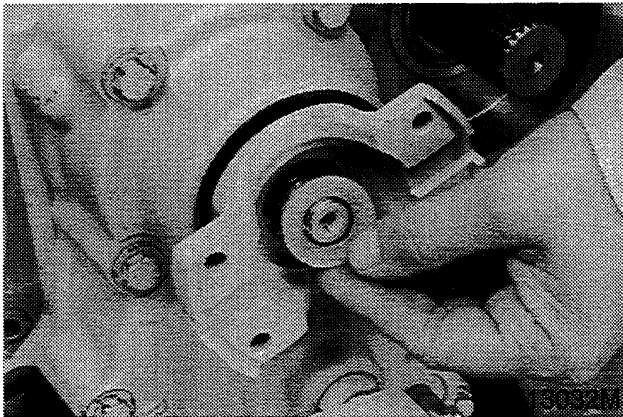

Install the seal washer.

STEP 200

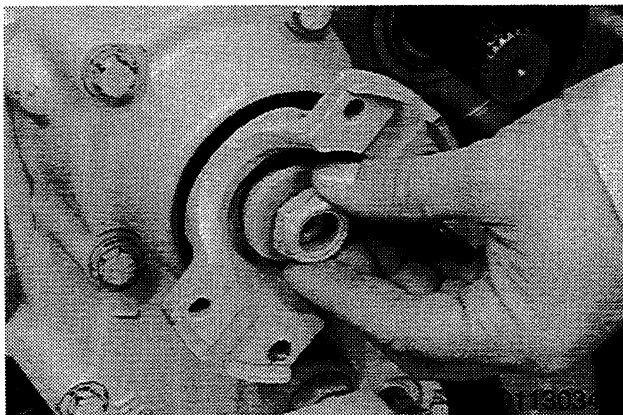

Install the washer and a new nut.

STEP 201

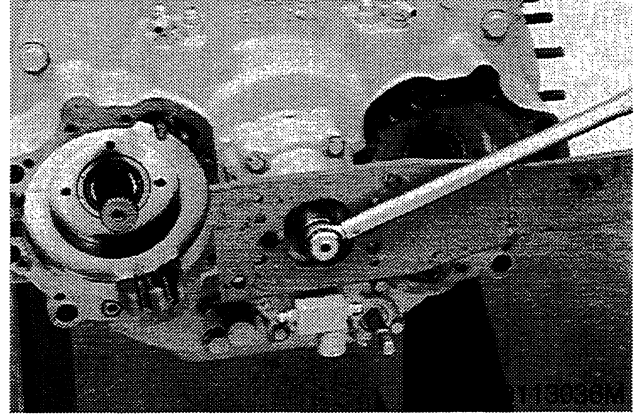

Tighten the nut to 150 to 165 pound-feet (203 to 224 Nm).

Adjusting End Play of the Shafts

STEP 202

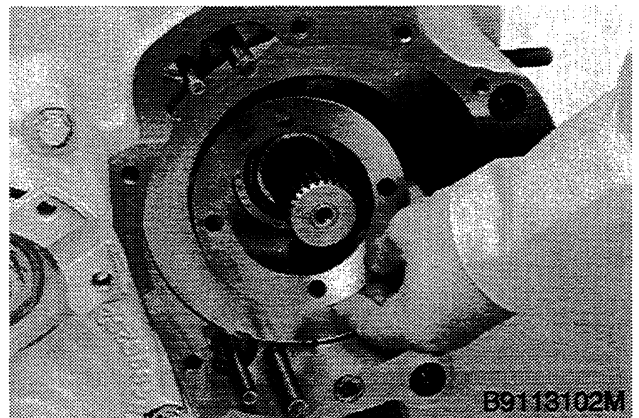

Install 0.040 inch (1 mm) of shims at the front of the pinion shafts.

STEP 203

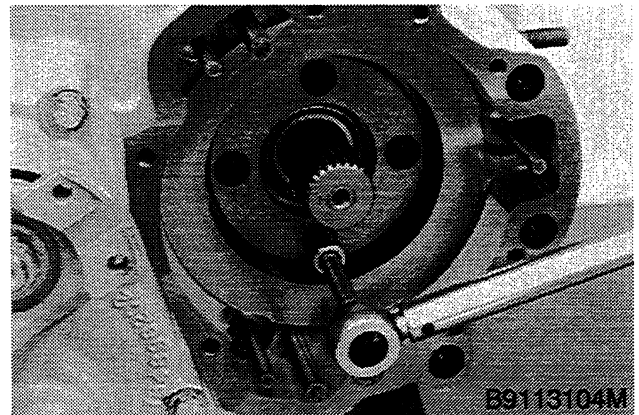

Install the retainer, bolts, and hardened washers. Tighten the bolts evenly to 360 to 480 pound-inches (40 to 54 Nm).

STEP 14

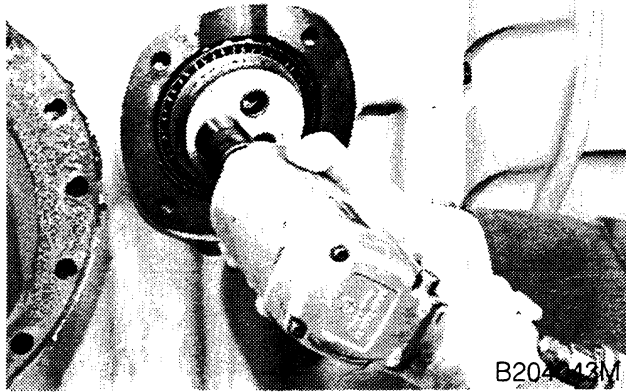

Loosen and remove the cap screws, retainer and shims.

Keep the retainer, it must be used as a tool during the assembly procedure, see step 44. Discard the cap screws, a new retainer and capscrews must be used for assembly.

STEP 15

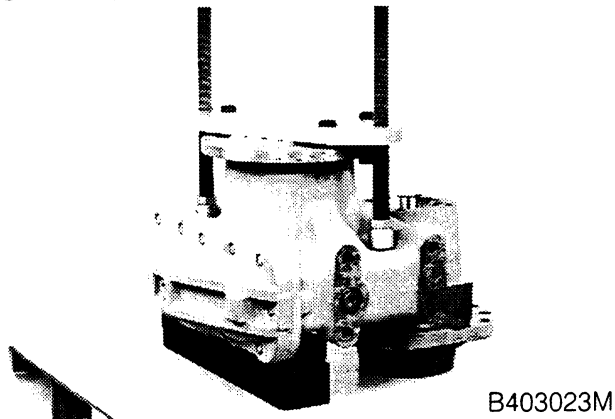

Fasten the CAS-1555 puller to the sprocket shaft.

STEP 16

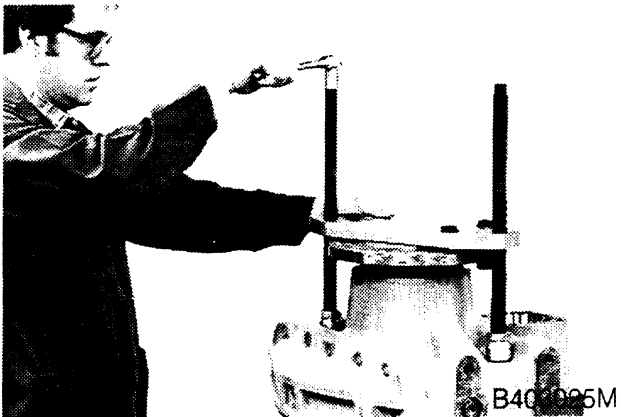

Tighten the studs evenly to remove the sprocket shaft from the inner bearing cone.

STEP 17

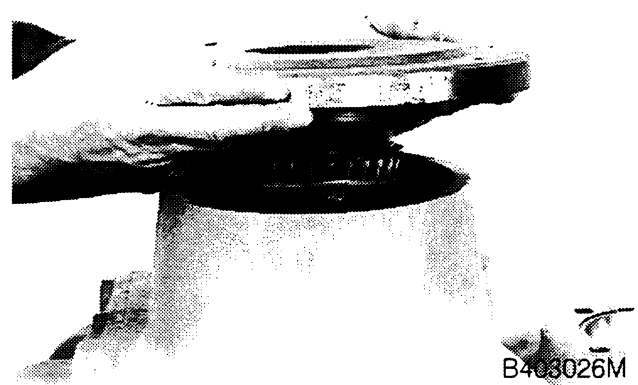

Remove the sprocket shaft.

STEP 18

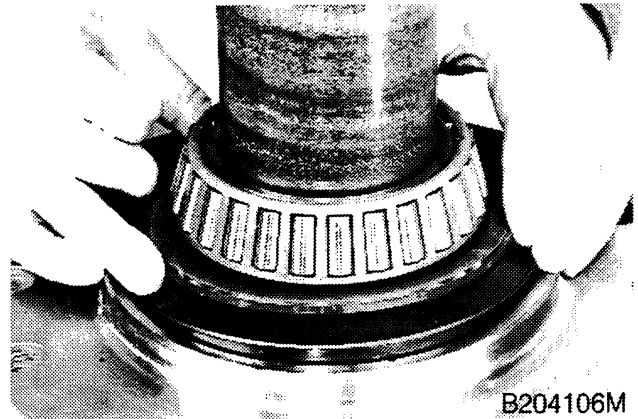

Remove the face seal from the sprocket shaft bore and housing.

NOTE: The face seal halves are a matched set. do not mix.

STEP 61

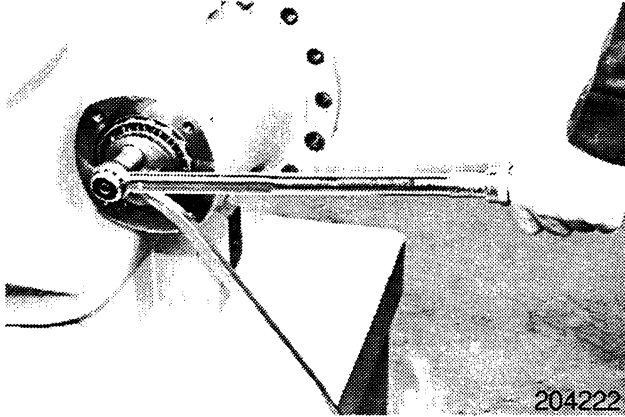

Prevent the input shaft from turning and tighten the cap screws 86 to 98 lb ft (116 to 132 Nm).

STEP 62



Put a new gasket on the cover. Install the cover and Ferry head screws.

STEP 63

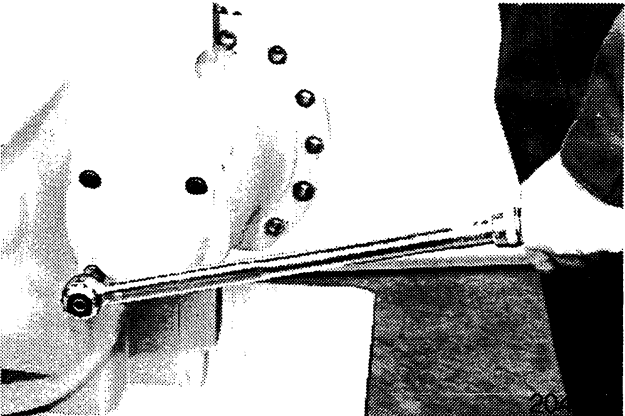

Tighten the Ferry head screws to 76 to 98 lb ft (102 to 132 Nm).

STEP 64

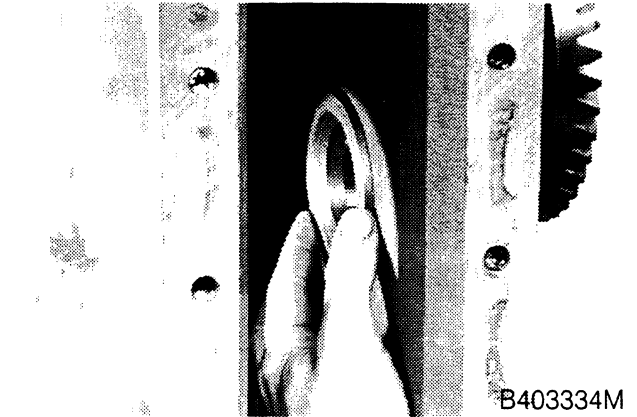

Install the spacer in the bore for the sprocket shaft so that the chamfer on the ID of the spacer is toward the inside.

STEP 65

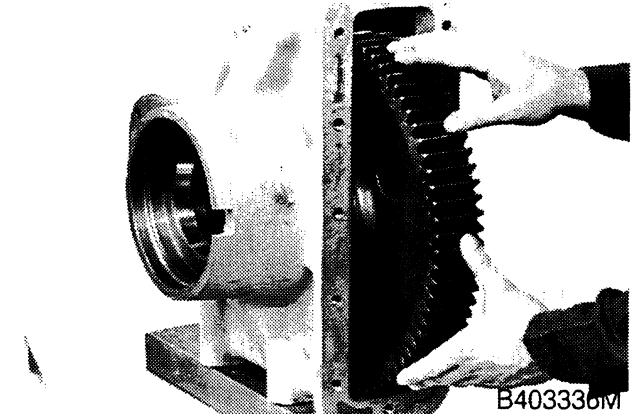

Install the bull gear.

STEP 66

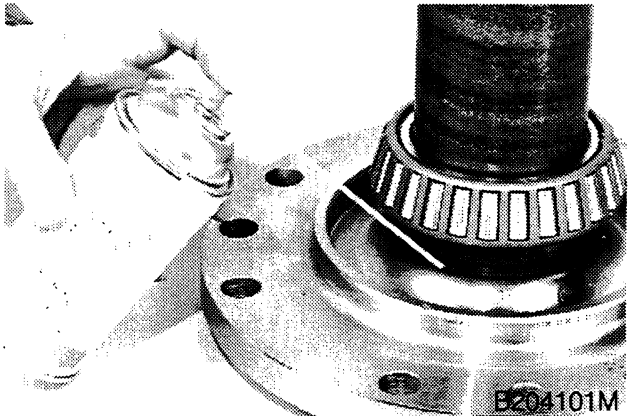

Remove any lubricant from the bore for the rubber ring in the sprocket shaft.

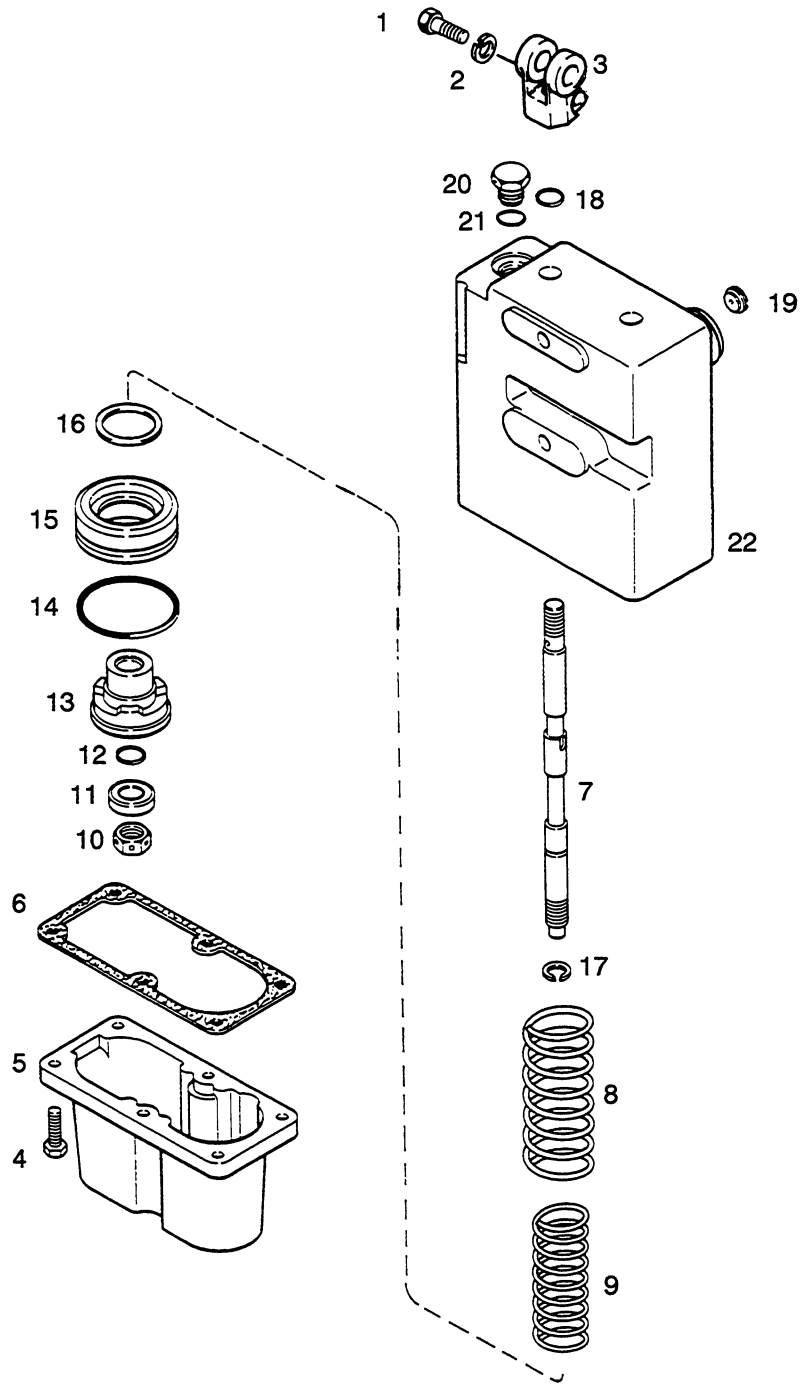

- 1. Cap Screw
- 2. Lock Washer
- 3. Yoke
- 4. Cap Screw
- 5. End Cover
- 6. Gasket

- 7. Spool
- 8. Outer Spring
- 9. Inner Spring
- 10. Lock Nut
- 11. Retainer
- 12. O-ring

- 13. Small Piston
- 14. Seal
- 15. Large Piston
- 16. Spring Seat
- 17. Snap Ring

- 18. O-ring
- 19. Restrictor
- 20. Plug
- 21. O-ring
- 22. Body

B911206J

STEP 25

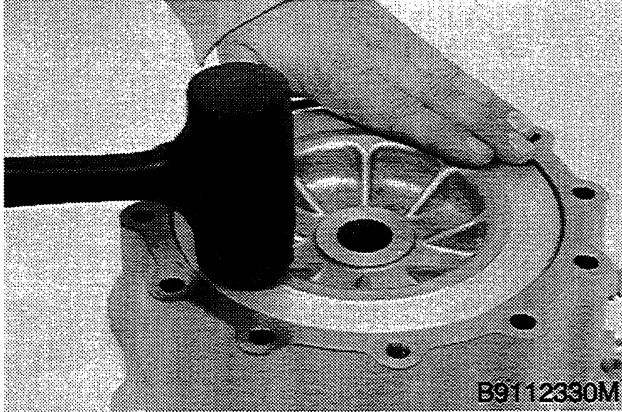

Install the other piston as shown in the photo.

STEP 26

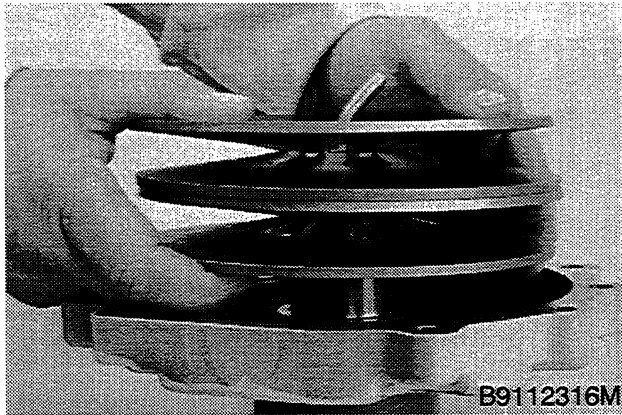

Install the four brake springs on the cover as shown in the photo.

STEP 27

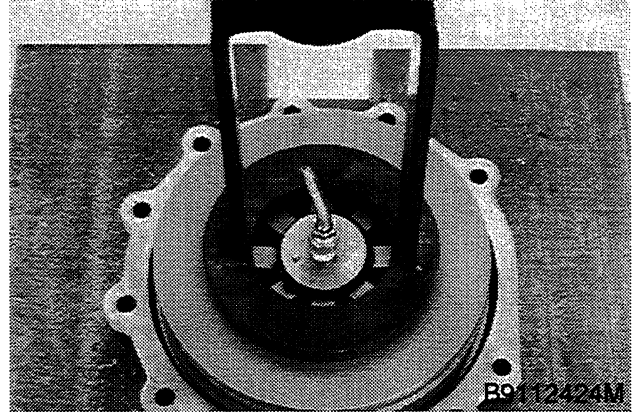

Put the cover in a press and use CAS-1460-1 pusher to compress the spring plates. Install the snap ring. Make sure the snap ring is seated in the groove. The sharp edge of the snap ring must be away from the springs.

NOTE: *Spring plates are under high tension. Use caution when installing the snap ring.*

SPECIAL TORQUE SPECIFICATIONS

- Mounting hardware for the equipment control valve.....204 to 252 pound-inches (23 to 28 Nm)
- Mounting hardware for equipment pump.....66 to 79 pound-feet (90 to 107 mm)

SPECIFICATIONS

Output of pump..... 17 U.S. gpm at 2000 psi at 2000 rpm (64 L/min at 13 790 kPa, 138 bar, at 2000 r/min)

Setting of main relief valve

Standard track machines..... 2450 to 2600 psi (16 892 to 17 927 kPa, 169 to 179 bar)

LGP machines..... 2150 to 2300 psi (14 824 to 15 858 kPa, 148 to 158 bar)

Hand pump setting for circuit relief valves (if equipped)

Auxiliary section, A and B port.....2700 to 2900 psi (18 617 to 19 995 kPa, 186 to 200 bar)

SPECIAL TOOLS

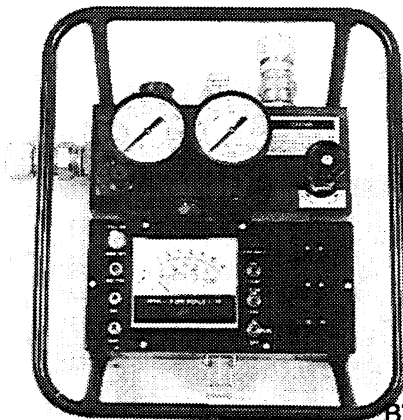

CAS-10280 Flowmeter

B785789M

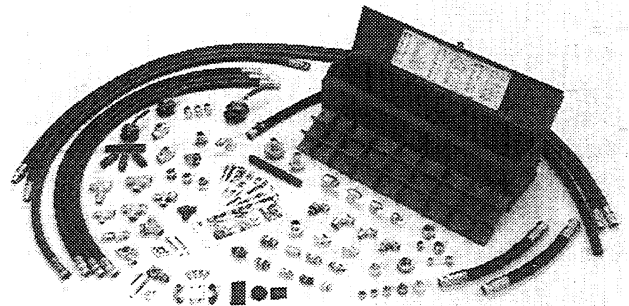

CAS-1808 or CAS-10106 Flowmeter Fitting Kit

B877168M

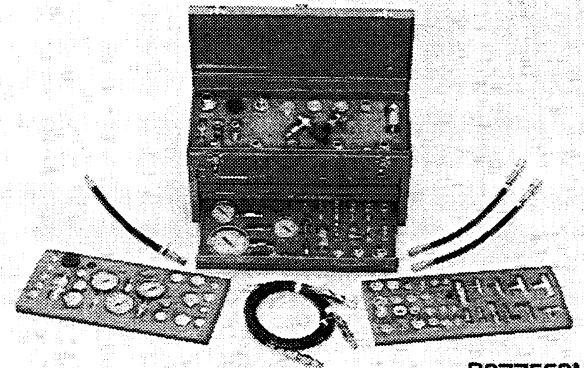

CAS-1804 or CAS-10111 Pressure Fitting Kit

B877558M

Section 8003

CLEANING THE HYDRAULIC SYSTEM

DISASSEMBLY

STEP 1

Clean the equipment pump.

STEP 2

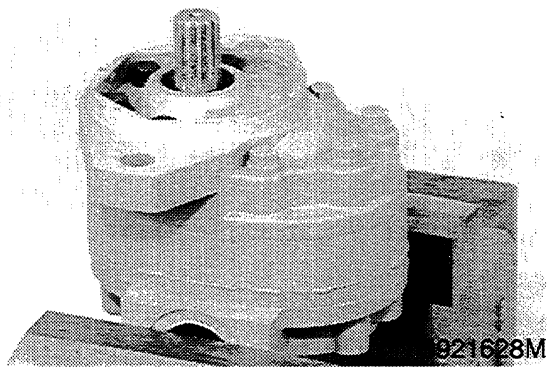

Put the pump in a vise with soft jaws.

STEP 3

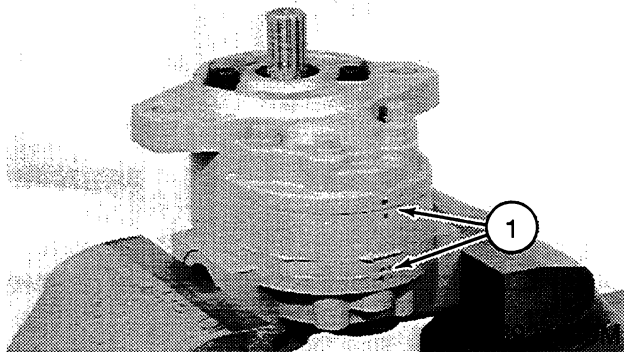

1. Alignment Marks

Make alignment marks on the parts of the pump.

STEP 4

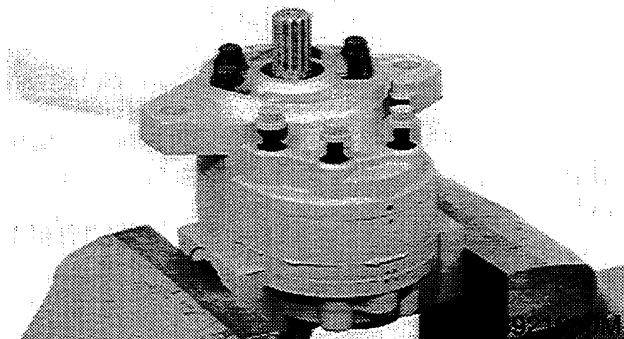

Remove the Ferry head screws.

STEP 5

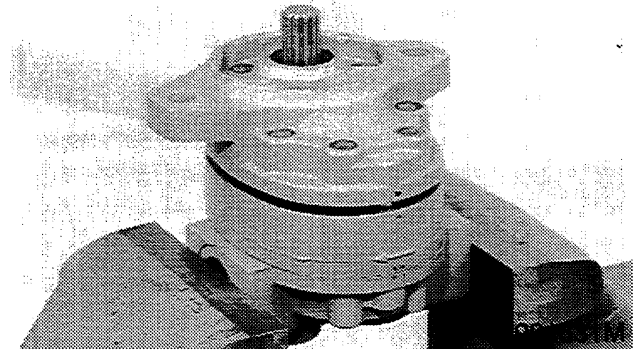

Remove the drive end cover. Do not lose the steel balls and springs under the drive end cover.

STEP 6

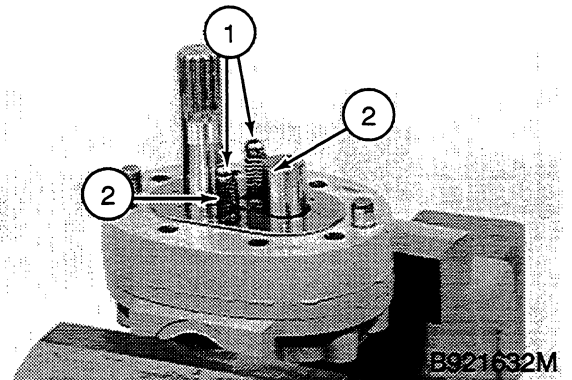

1. Steel Balls

2. Springs

Remove the steel balls and springs.

STEP 7

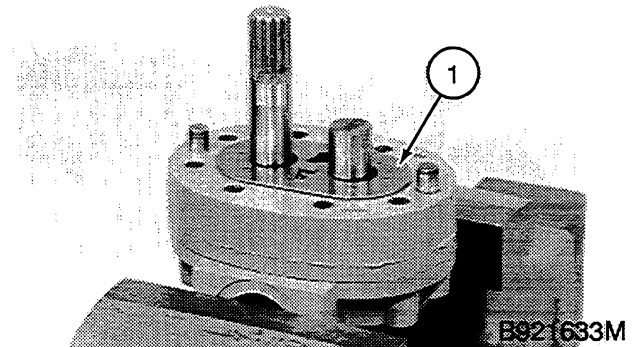

1. Diaphragm

Remove the diaphragm.

SPECIFICATIONS

ManufacturerGresen

Pressure Settings

Main relief valve and circuit relief valves See Section 8002 for specifications and instructions

Spool Travel

Neutral to pressure.....0.31 inch (7.9 mm)

Neutral to float.....0.53 inch (13.5 mm)

Special Torques

Bolts and nuts that fasten the sections together.....346 to 422 pound-inches (39 to 47 Nm)

Relief valves and load check valves216 to 264 pound-inches (24 to 30 Nm)

Allen head screws48 to 108 pound-inches (5 to 12 Nm)

SPECIAL TOOL

The following special tool is used to compress the centering springs on the spools.

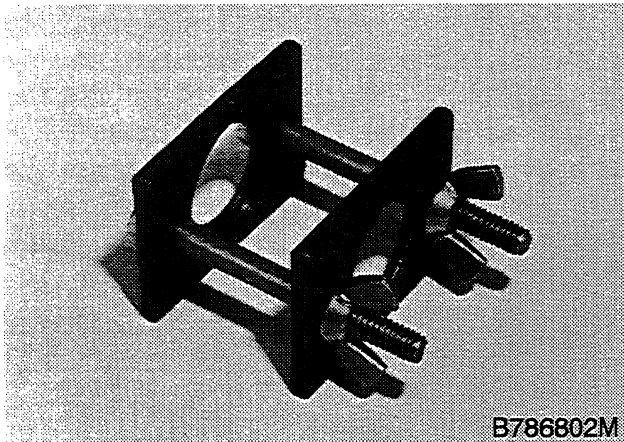

B786802M

CAS-1147-2 Spring Centering Tool. Shown in use on page 10

TILT, ANGLE, AND AUXILIARY SECTIONS

See the illustration on page 17. The auxiliary section has a circuit relief valve at each end of the section. The tilt and angle sections have a load check valve at each end of the section. The following photos show a tilt or angle section. Use a similar procedure to disassemble the other tilt or angle and auxiliary sections.

Disassembly

STEP 31

Fasten the section in a vise with soft jaws.

STEP 32

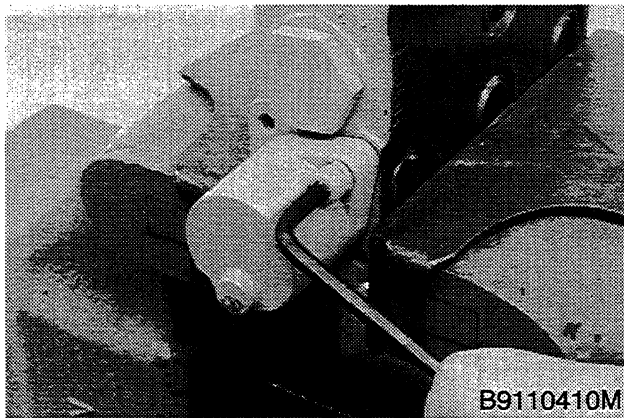

Loosen the Allen head screws that fasten the spring cap to the body.

NOTE: For assembly, tighten the Allen head screws 48 to 108 pound-inches (5 to 12 Nm).

STEP 33

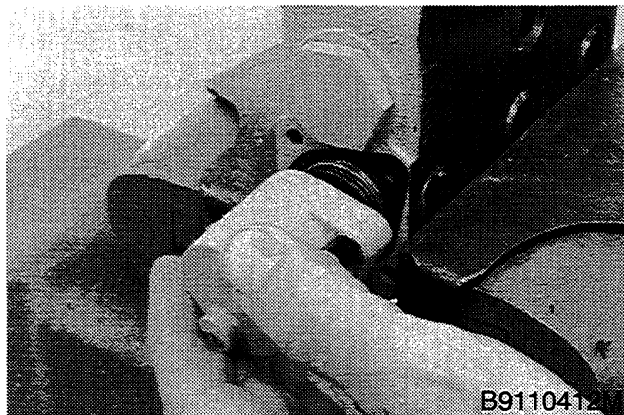

Remove the Allen head screws and spring cap.

STEP 34

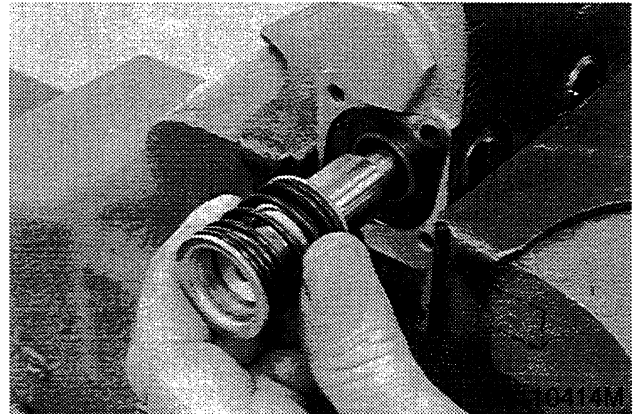

Pull the spool from the body.

STEP 35

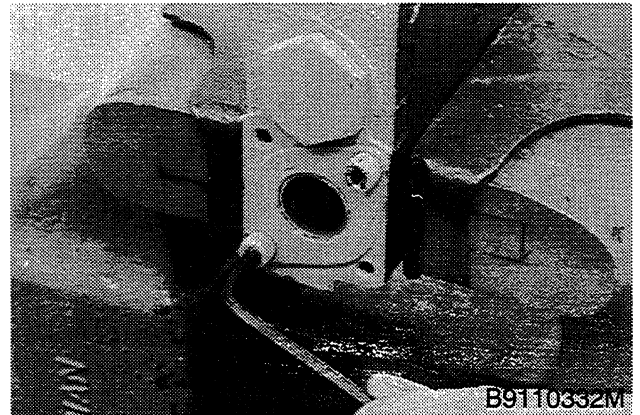

Remove the Allen head screws that fasten the plate to the body.

NOTE: For assembly, tighten the Allen head screws 48 to 108 pound-inches (5 to 12 Nm).

STEP 36

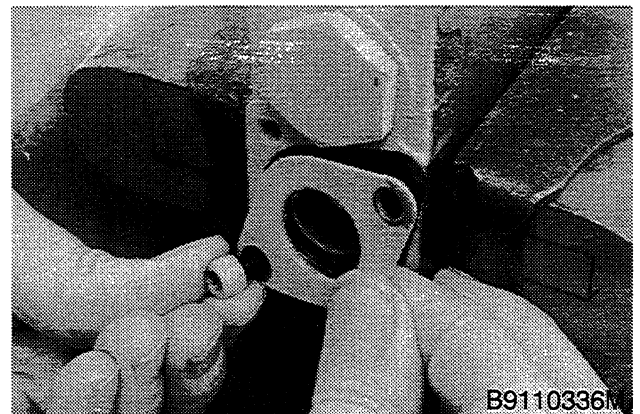

Remove the plate.

INSPECTION

1. Discard all O-rings, backup rings, wipers, and seals.
2. Clean all parts in cleaning solvent.
3. Check the seals for the load check valves inside the bodies of the sections.
4. Check the spools and spool bores for damage and wear.
5. Check the parts of the main relief valve and circuit relief valves. Use new parts as necessary.
6. Inspect the other parts of the dozer control valve. If any of the parts are damaged, install new parts.

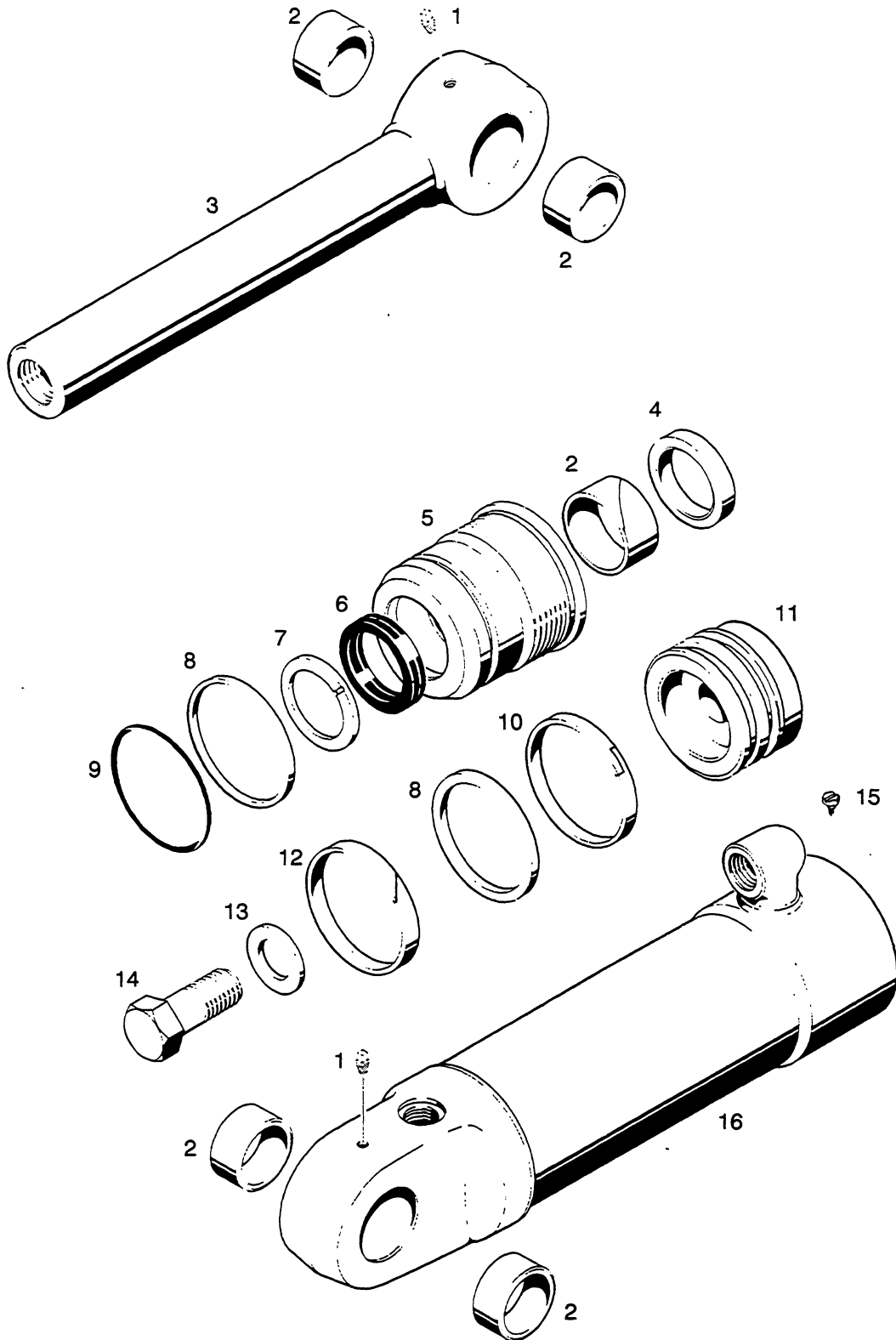

- 1. Plug
- 2. Bushing
- 3. Piston Rod
- 4. Wiper
- 5. Gland
- 6. Wide Seal

- 7. Narrow Seal
- 8. Backup Ring
- 9. O-ring
- 10. Wear Ring
- 11. Piston

- 12. Seal
- 13. Hardened Washer
- 14. Cap Screw
- 15. Self-Tapping Screw
- 16. Tube

Tilt Cylinder

B911496J

TABLE OF CONTENTS

| | |
|---|----|
| SPECIAL TOOLS | 2 |
| ADJUSTMENT OF THROTTLE LINKAGE | 3 |
| ADJUSTMENT OF BLADE CONTROL LEVERS | 5 |
| ADJUSTMENT OF CONTROL LEVERS FOR BACKHOE..... | 6 |
| ADJUSTMENT OF DIRECTION CONTROL LINKAGE..... | 7 |
| ADJUSTMENT OF NEUTRAL START SWITCH..... | 9 |
| ADJUSTMENT OF TRACK SPEED CONTROL LINKAGE | 10 |
| ADJUSTMENT OF RANGE CONTROL LINKAGE..... | 10 |
| ADJUSTMENT OF BRAKE PEDALS | 11 |
| ADJUSTMENT OF CLUTCH CUTOFF LINKAGE | 12 |

SPECIAL TOOLS



B875112M

CAS-10778 Tachometer and Sensor. Not Shown in Use.

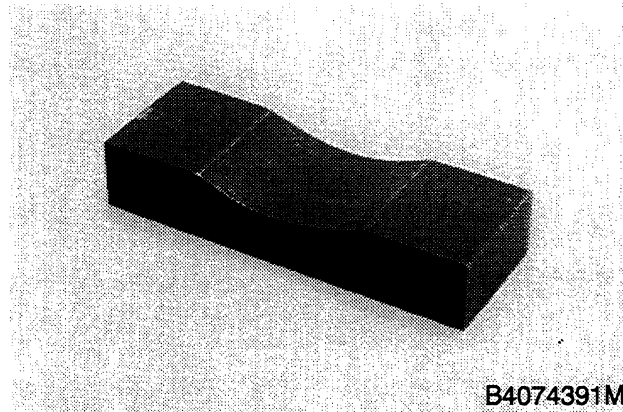

B4074391M

CAS-2224 F/R Gauge Block From Transmission Repair Kit CAS-40019. Not Shown in Use.

ADJUSTMENT OF CLUTCH CUTOUT LINKAGE

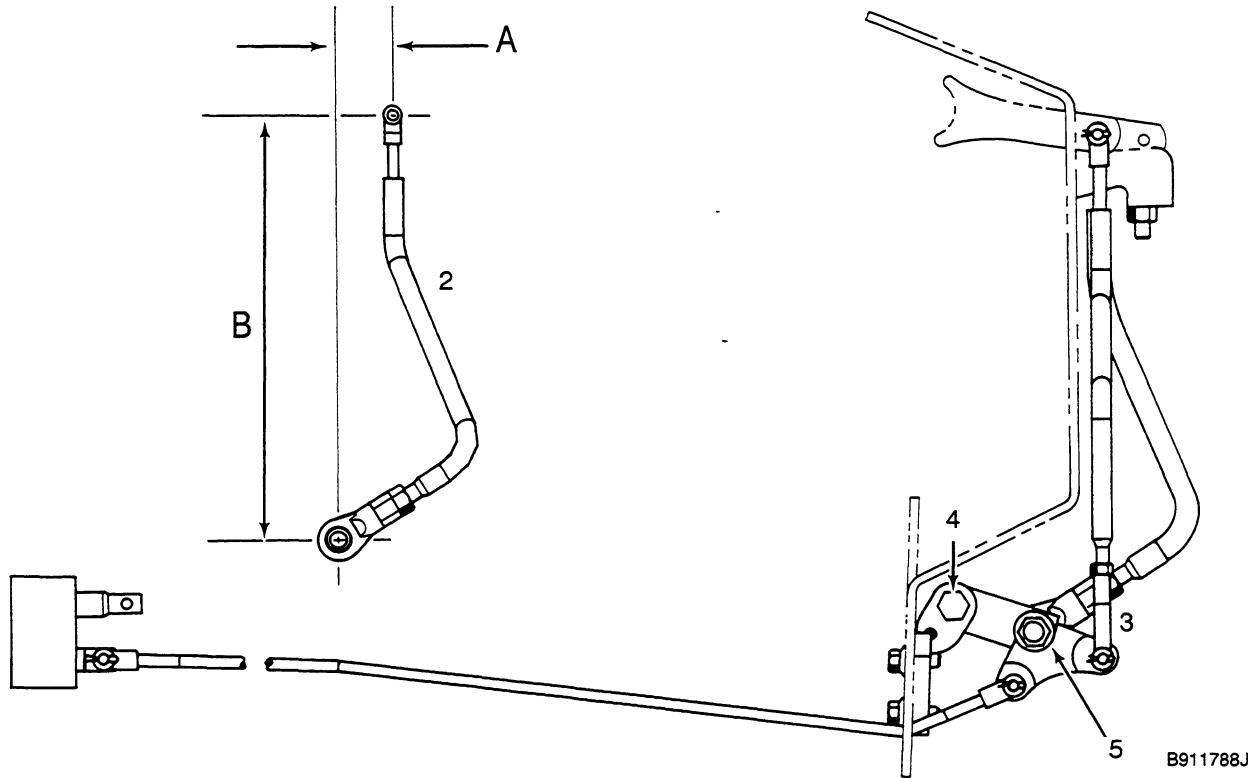

A. 1.8 Inch (46 mm)

B. 13.4 Inch (340 mm)

1. Do Brake Pedal Adjustment before doing this adjustment.

2. Adjust length of center control rod (2) as required. Adjustment is needed when a new control rod or ball joint is installed. Adjust center control rod to specified length as shown.

3. Adjust length of outer control rods (3) to remove all free travel from clutch cutout linkage.

4. Tighten self-locking nut on bolt (4) to remove all end play for pivot block yet lets pivot block move freely.

5. Tighten self-locking nut to remove all end play for the bellcranks (5) yet lets the bellcranks move freely.

6. Push down and release brake pedals 5 times to make sure brake pedals move freely and easily.

7. With engine running at low idle, push down left brake pedal and read transmission pressure gauge. The reading must be zero (0) pressure. Repeat this step for the right brake pedal.

8. With engine running at low idle, push down center brake pedal and read transmission pressure gauge. The reading must be 275 to 305 psi (1896 to 2103 kPa, 19 to 21 bar).

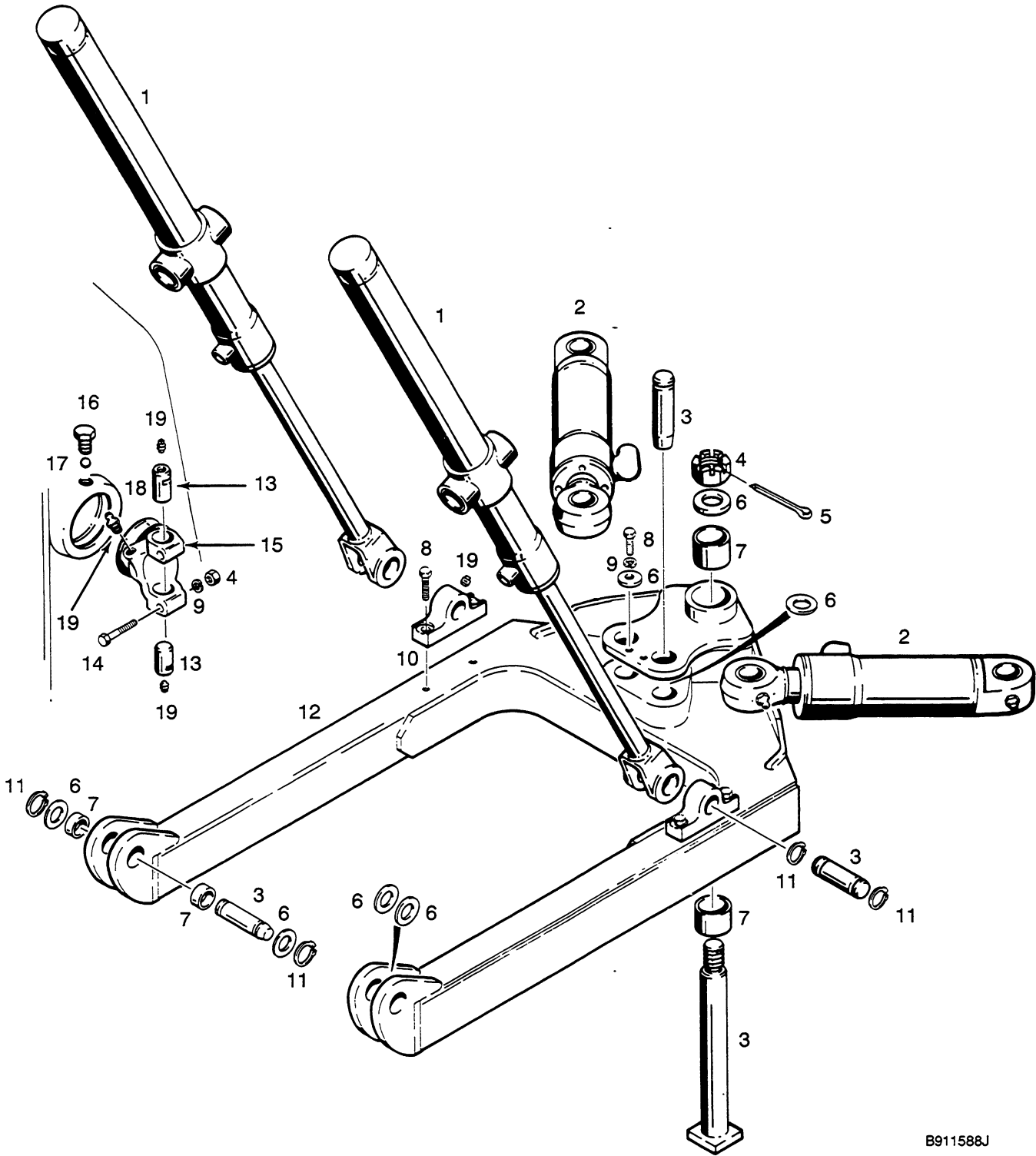

B911588J

- 1. Lift Cylinder
- 2. Angle Cylinder
- 3. Pivot Pin
- 4. Nut
- 5. Cotter Pin

- 6. Washer
- 7. Bushing
- 8. Cap Screw
- 9. Lock Washer
- 10. Mount

- 11. Snap Ring
- 12. C-frame
- 13. Trunnion Pin
- 14. Bolt
- 15. Trunnion Holder

- 16. Plug
- 17. Steel Ball
- 18. Race
- 19. Grease Fitting

CLICK HERE TO **DOWNLOAD** THE COMPLETE MANUAL

- Thank you very much for reading the preview of the manual.
- You can download the complete manual from: www.heydownloads.com by clicking the link below



- Please note: If there is no response to CLICKING the link, please download this PDF first and then click on it.

CLICK HERE TO **DOWNLOAD** THE COMPLETE MANUAL