

ZX 75

IR *Ingersoll Rand*
Utility Equipment

Service Manual

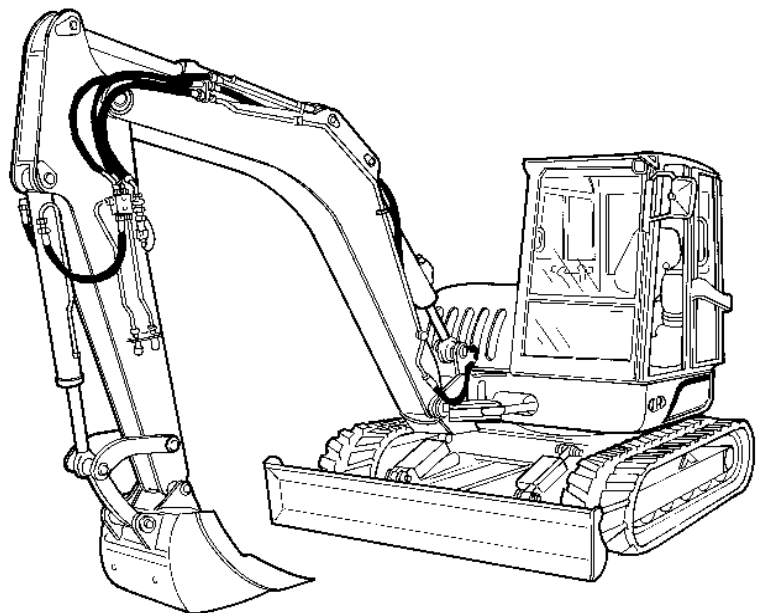

CLICK HERE TO **DOWNLOAD** THE COMPLETE MANUAL

- Thank you very much for reading the preview of the manual.
- You can download the complete manual from: www.heydownloads.com by clicking the link below



- Please note: If there is no response to **CLICKING** the link, please download this PDF first and then click on it.

CLICK HERE TO **DOWNLOAD** THE COMPLETE MANUAL

SERIAL NUMBER LOCATIONS

Always use the serial number of the excavator when requesting service information or when ordering parts. Early or later models (identification made by serial number) may use different parts, or it may be necessary to use a different procedure in doing a specific service operation.

Excavator Serial Number

Figure 1

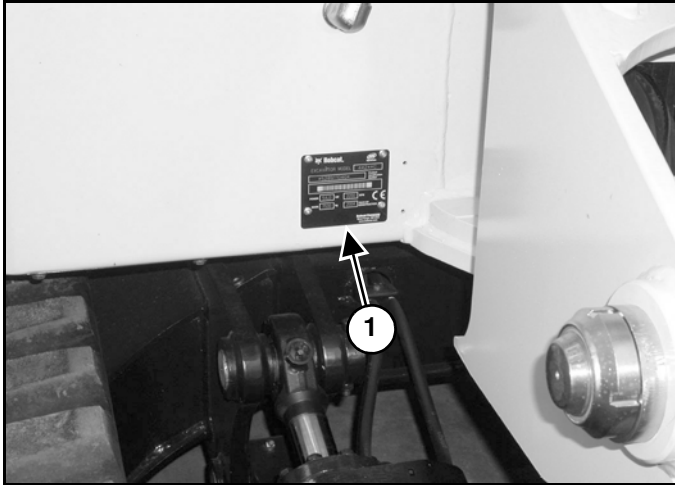

The excavator serial number plate (Item 1) is located on the frame of the machine in the location shown [Figure 1].

Explanation of Excavator Serial Number:

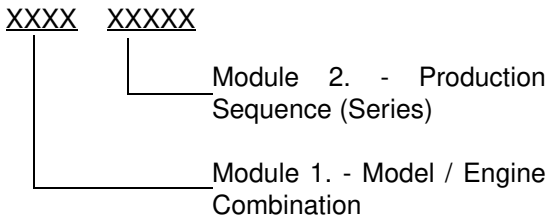

1. The four digit Model/Engine Combination Module number identifies the model number and engine combination.

2. The five digit Production Sequence Number identifies the order which the excavator is produced.

Engine Serial Number

Figure 2

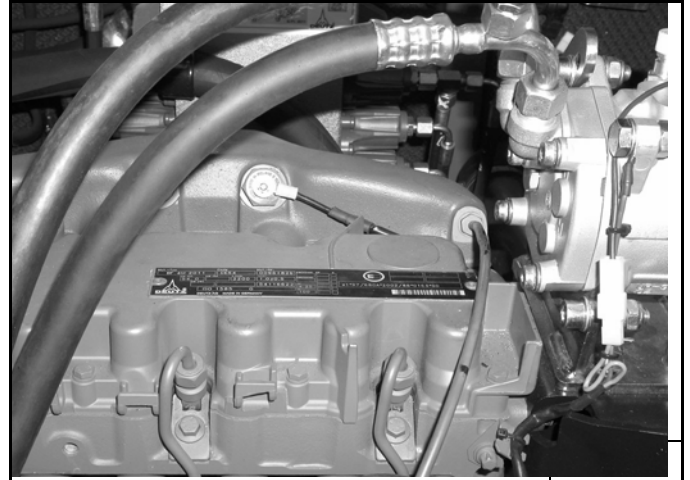

The engine serial number (Item 1) [] & [Figure 2] is located on the engine in the locations shown.

HYDRAULIC EXCAVATOR SPECIFICATIONS

Engine

Make	Deutz
Model	BF4M 2011
Fuel	Diesel/Liquid (Oil cooled)
Horsepower	73 HP (54 kW) @ 2200 RPM
Maximum Governed RPM (Full Load)	NA
Maximum Torque	NA
High Idle RPM	2200
Low Idle RPM	900
No. of Cylinders	Four
Displacement	190 cu.in. (3108 cm)
Bore x Stroke	3.7 (94 mm) X 4.4 (112 mm)
Lubrication	Pressure System W/Filter
Filter	Cartridge type - Full Flow
Air Cleaner	Dry replaceable paper cartridge, dual element

Electrical

Starter	12 Volt (2,0 kW) Reduction Drive
Alternator	14 Volt, 55 Amps, open, negative ground
Battery	12 Volt, 450 Cold Crank Amps. @ 0°F (-18°C)



Hydraulic System

Variable Displacement Piston Pump	37.5 GPM (142 L/min)
Gear Pumps (2 combined)	17.4 GPM (66 L/min)
System Relief Settings -Gear Pump	3335 PSI (230 bar)
-Piston Pump	4060 PSI (280 bar)
Swing Blade And Boom Swing Circuits	3335 PSI (230 bar)
Bucket, Arm, Boom and Travel Circuits	4060 PSI (280 bar)
Auxiliary Flow	26.42 GPM (100 LPM)
Control Valves	Three Spool Open Center Valve, Six Spool Closed Center
Drive Motors	2 Axial Piston
Swing Motor	Piston Motor

FUEL, COOLANT AND LUBRICANTS (CONT'D)

Chart

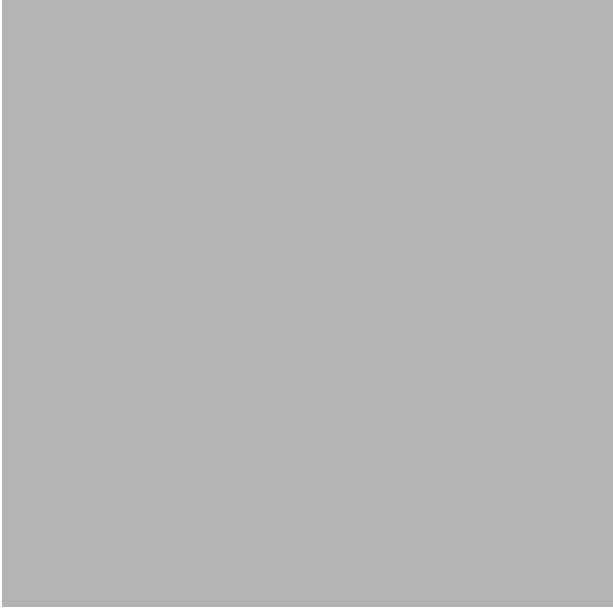
Use this chart for correct selection of Fuel, Coolant and Lubricants.

RESERVOIR	KIND OF FLUID	RECOMMENDED SAE VISCOSITY NUMBER (LUBRICATION OILS FOR DIESEL ENGINE CRANKCASE)			CAPACITY
					REFILL
Engine oil/ Engine coolant	*Use SAE Viscosity Number as Listed With API Classification CD or Better				14.8 qts. (14 L) System Capacity 10 qts (9.4 L) w/ filter oil change
Fuel	**Diesel Fuel	Temp. F° +15° (9°) Down to -20° (-29°) Below -20° (-29°)	No. 2 100% 50% 0%	No. 1 0% 50% 100%	34 gal. (130 L)
Hydraulic Tank	IR Fluid				Tank Cap. 29 gal. (110 L)
Drive Motors (each side)	Gear Lube	SAE - 80 W-90 LS			1.9 qts. (1,8 L)

OPERATOR CAB

Description

The excavator has an operator cab as standard equipment.



Never modify operator cab by welding, grinding, drilling holes or adding attachments unless instructed to do so by Bobcat.

Entering And Exiting The Excavator

Figure 10-20-1



Use the grab handles and track to enter and exit the excavator [Figure 10-20-1].

Raising And Lowering The Left Console

Raise the console before exiting the cab.

Figure 10-20-2



Pull up on the handle (Item 1) [Figure 10-20-2] The lift spring will assist in raising the console.

Lower the console before operating the excavator.

Push down on the handle (Item 1) [Figure 10-20-2] until the console is in the down position.

NOTE: When the console is raised, the hydraulic and traction systems are locked and will not operate.

AIR CLEANER

Daily Check

See the Service Schedule for the correct service interval. (See SERVICE SCHEDULE on Page 10-50-1.)

Figure 10-60-1

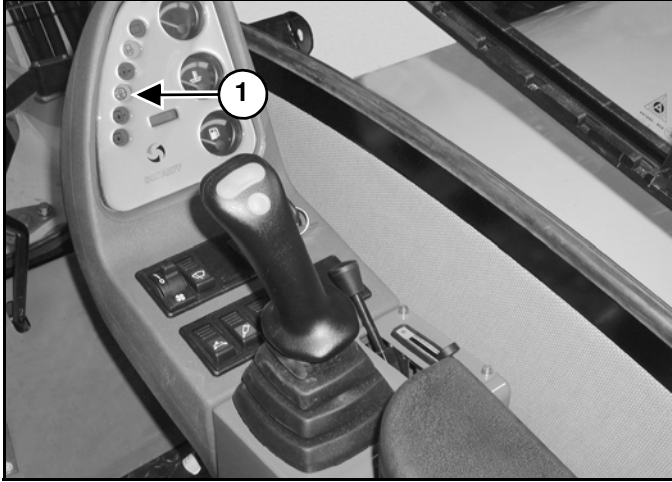

If the air filter condition indicator (Item 1) [Figure 10-60-1] is illuminated, the filter element needs to be replaced.

Open the right side cover. (See RIGHT SIDE COVER on Page 10-41-1.)

Figure 10-60-2

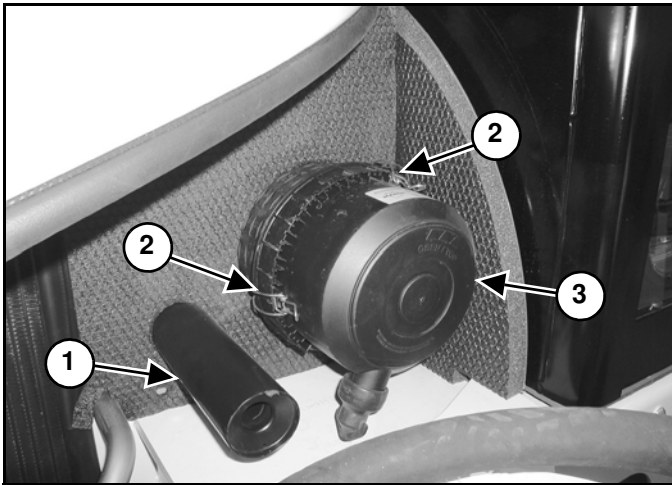

Inspect the air intake (Item 1) [Figure 10-60-2] for damage or restrictions.

Replacing The Filters

Outer Filter

Unlatch the air filter cover latches (Item 2) [Figure 10-60-2].

Remove the air filter cover (Item 3) [Figure 10-60-2].

Figure 10-60-3

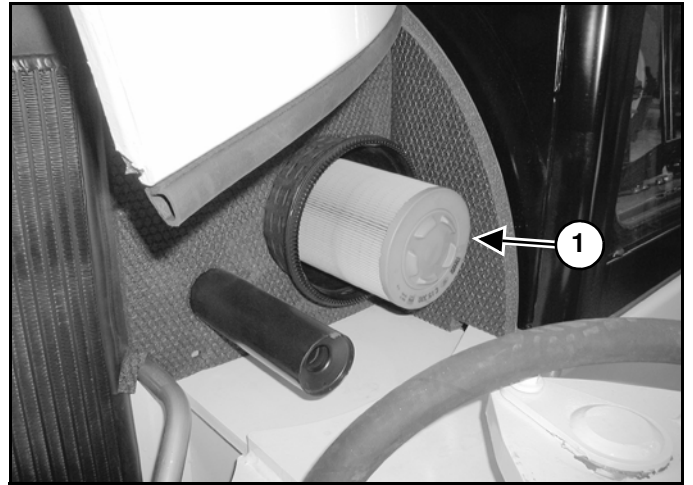

Remove the outer filter (Item 1) [Figure 10-60-3].

Check the housing for damage.

Clean the housing and seal surface. Do not use compressed air.

Install the outer filter.

Install the cover.

FUEL SYSTEM (CONT'D)

Fuel Filter Removal And Installation

See the Service Schedule for the service interval when to replace the fuel filter. (See SERVICE SCHEDULE on Page 10-50-1.)

Clean the area around the filter.

Figure 10-80-4

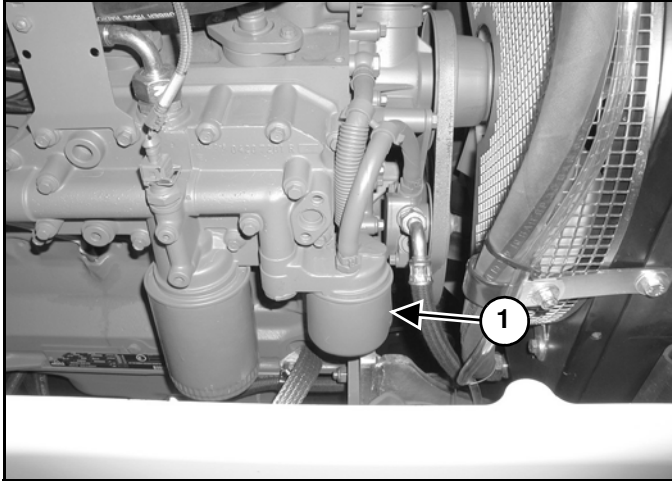
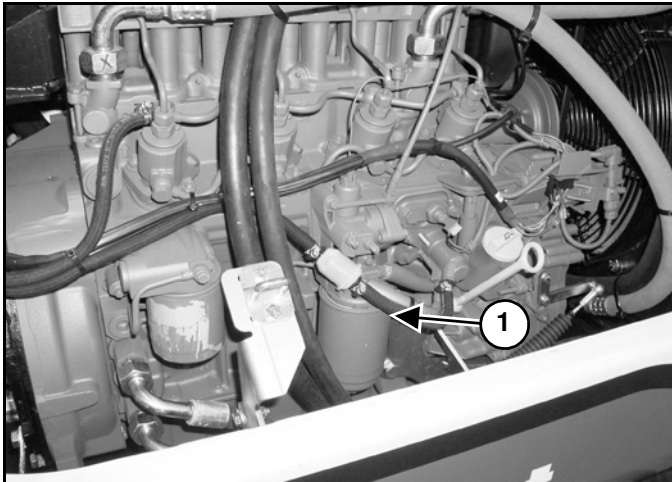

Figure 10-80-5



Remove the filter (Item 1) [Figure 10-80-4] & [Figure 10-80-5].

Put clean oil on the seal of the new filter.

Install the filter and hand tighten.

HYDRAULIC SYSTEM (CONT'D)

Hydraulic Filter Installation (Cont'd)

Figure 10-100-12

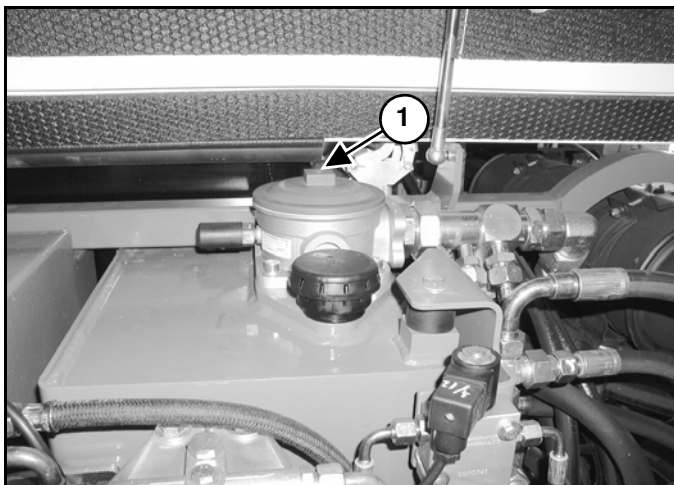

Install the spring and cover (Item 1) [Figure 10-100-12].

TRAVEL MOTOR

Checking Oil Level

Figure 10-120-1

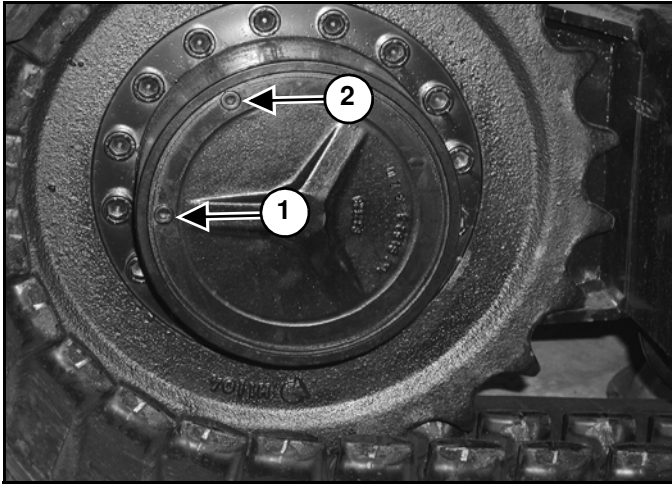

Put the machine on a level surface with the plugs positioned as shown (Items 1 & 2) **[Figure 10-120-1]**

Remove the plug (Item 1) **[Figure 10-120-1]**. The oil level should be at the bottom edge of the plug hole.

Remove the plug (Item 2) **[Figure 10-120-1]** and add gear lube through the hole if the oil level is below the hole (Item 1) **[Figure 10-120-1]**. (See FUEL, COOLANT AND LUBRICANTS (CONT'D) on Page Spec-70-1.)

Install both plugs.

Repeat the procedure for the other side.

Draining The Travel Motor

See the Service Schedule for the correct service interval. (See SERVICE SCHEDULE on Page 10-50-1.)

Figure 10-120-2

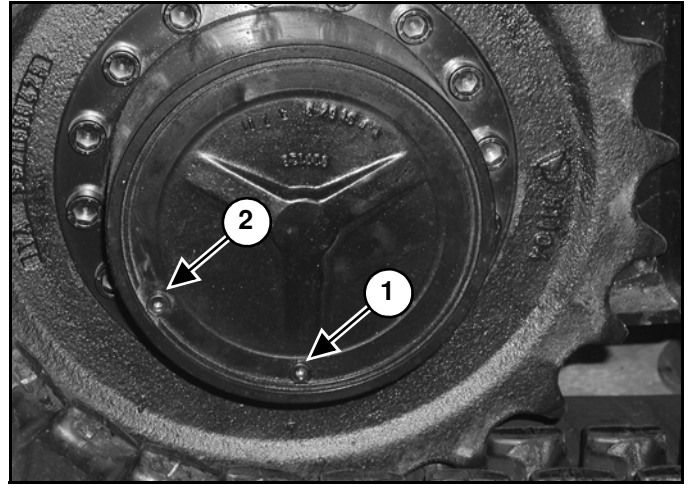

Put the machine on a level surface with the plugs positioned as shown (Items 1 & 2) **[Figure 10-120-2]**

Remove both plugs (Items 1 & 2) **[Figure 10-120-2]** and drain into a container. Recycle or dispose of the oil in an environmentally safe manner.

After all the gear lube is removed, rotate the travel motor to the position shown **[Figure 10-120-1]**

Add gear lube to the plug hole (Item 2) until the oil level is at the bottom edge of the plug hole (Item 1) **[Figure 10-120-1]**. Install and tighten the plugs.

Repeat the procedure for the other side.

CAB TILT PROCEDURE (CONT'D)

Tilting The Cab (Cont'd)

Figure 10-160-9

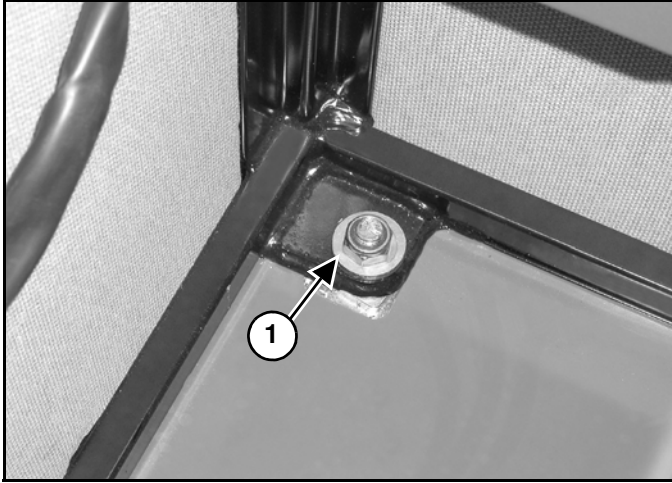
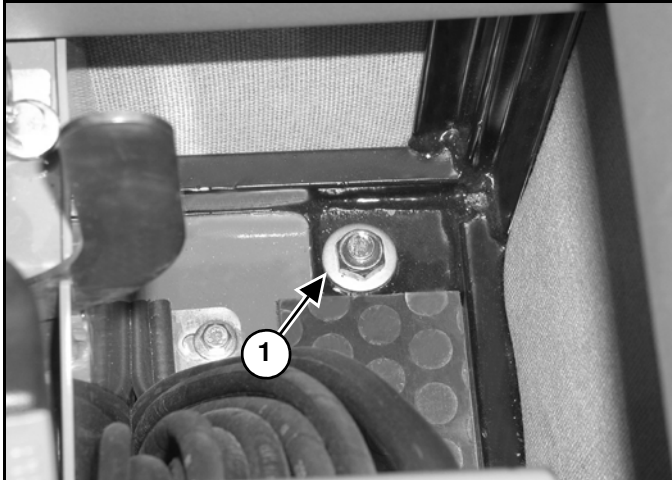

Figure 10-160-10



Remove the rear cab mount nuts (Item 1) [Figure 10-160-9] & [Figure 10-160-10] and washers.

Installation: Tighten the nuts to 81-92 ft.-lb. (110-125 N·m) torque.

Figure 10-160-11

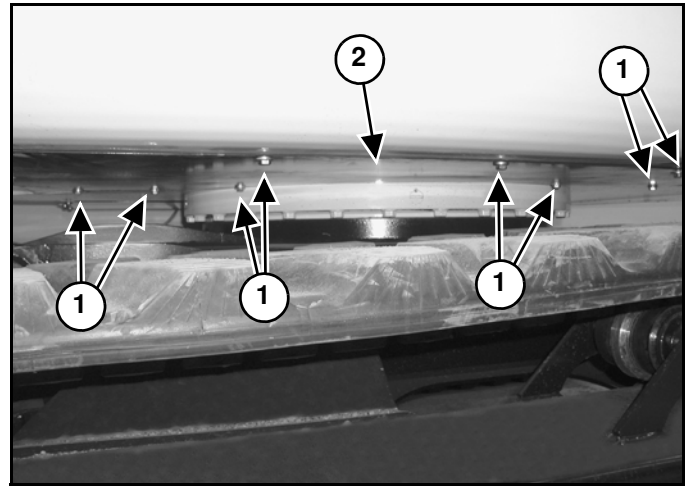

Remove the 11 bolts (Item 1) and washers. Remove the bottom cover (Item 2) [Figure 10-160-11]

Installation: Tighten the bolts to 18-19 ft.-lb. (110-125 N·m) torque.

HYDRAULIC SYSTEM (CONT'D)

RELIEF VALVES	20-30-1
Adjusting The Three Spool Control Valve Main Relief Valve	20-30-2
Description	20-30-1
Testing The Three Spool Control Valve Main Relief Valve	20-30-2
RIGHT CONTROL LEVER (JOYSTICK)	20-110-1
Disassembly And Assembly	20-110-6
Handle Removal And Installation	20-110-2
Parts Identification	20-110-5
Removal And Installation	20-110-3
Testing	20-110-1
SECONDARY FRONT AUXILIARY VALVE	20-150-1
Disassembly And Assembly	20-150-3
Parts Identification	20-150-2
Removal And Installation	20-150-1
SIX SPOOL HYDRAULIC CONTROL VALVE	20-40-1
Boom, Arm, Bucket And Auxiliary Valve Section Disassembly And Assembly	20-40-12
Control Valve Identification	20-40-5
Disassembly And Assembly	20-40-6
Inlet Valve Section Disassembly And Assembly	20-40-17
Left Travel And Right Travel Valve Section Disassembly And Assembly	20-40-9
Removal And Installation	20-40-1
SWING BRAKE RELEASE VALVE	20-93-1
Disassembly And Assembly	20-93-3
Parts Identification	20-93-2
Removal And Installation	20-93-1
SWING BRAKE VALVE	20-92-1
Disassembly And Assembly	20-92-3
Parts Identification	20-92-2
Removal And Installation	20-92-1
SWING MOTOR	20-90-1
Assembly	20-90-10
Disassembly	20-90-4
Parts Identification	20-90-3
Removal And Installation	20-90-1

Continued On Next Page

BOOM CYLINDER

Testing

Fully retract the bucket and arm cylinders.

Lower the boom to the ground.

With the engine off and the key in the run position, move the joysticks to relieve hydraulic pressure.

Figure 20-20-1

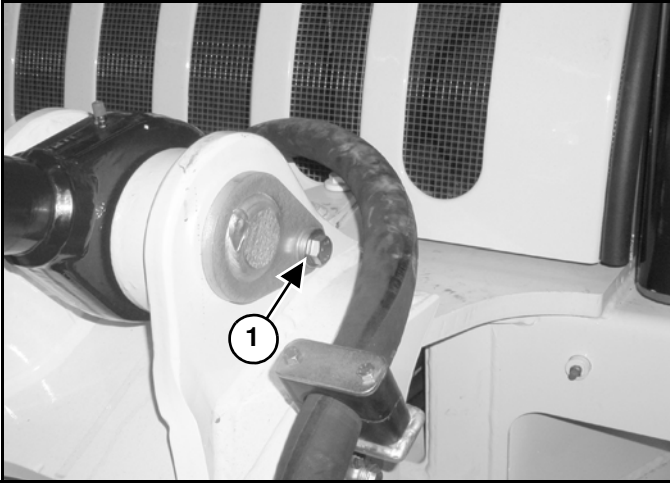

Remove the bolt (Item 1) [Figure 20-20-1] from the rod end retaining pin.

Figure 20-20-2

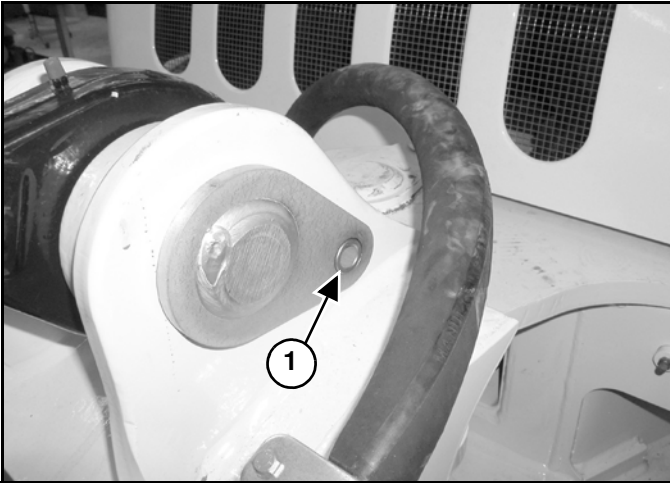

Remove the spacer (Item 1) [Figure 20-20-2].

Figure 20-20-3

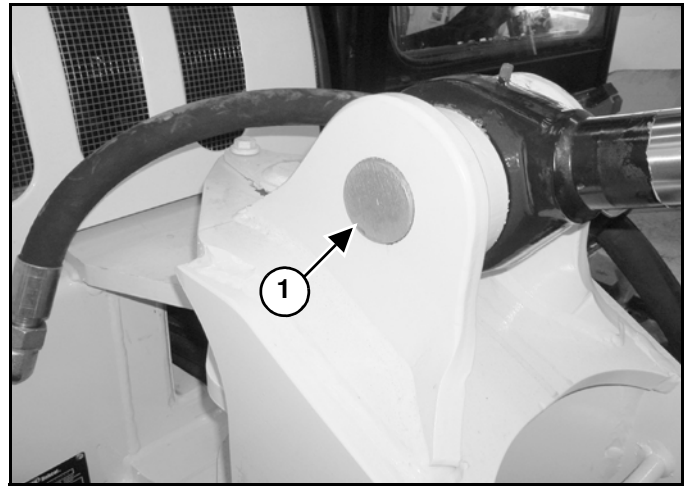

Remove the pin (Item 1) [Figure 20-20-3].

Figure 20-20-4

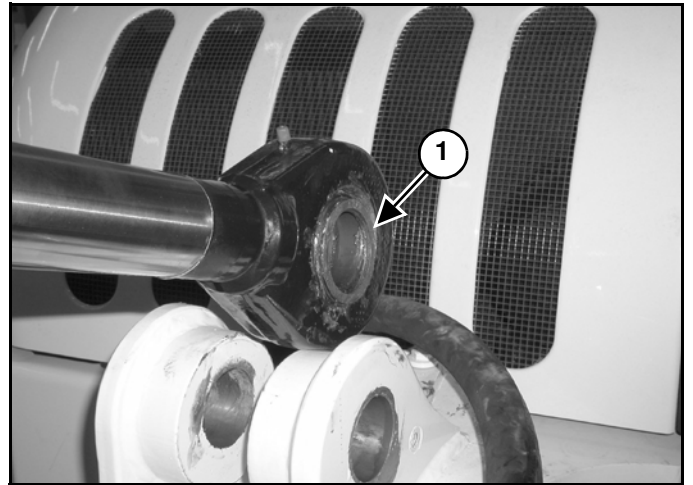

Raise the cylinder and remove the shims (Item 1) [Figure 20-20-4] from both sides of the rod end.

BOOM CYLINDER (CONT'D)

Disassembly (Cont'd)

Figure 20-20-34

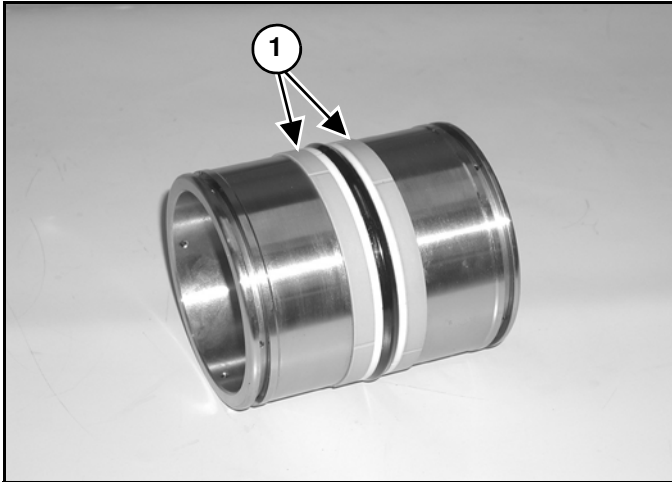

Remove the wear rings (Item 1) [Figure 20-20-34].

Figure 20-20-35

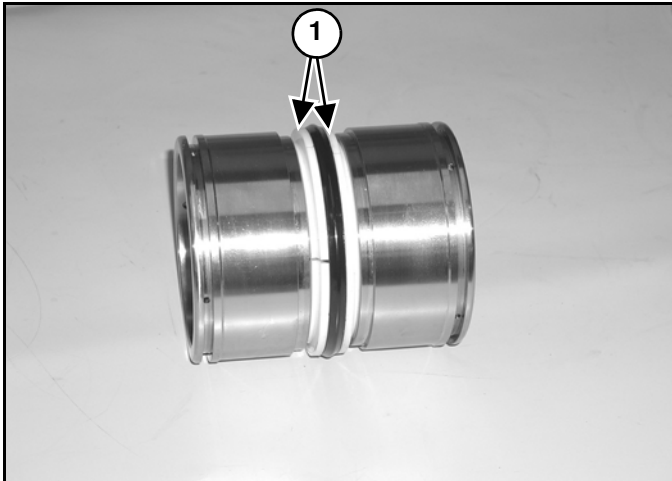

Remove the back-up rings (Item 1) [Figure 20-20-35].

Figure 20-20-36

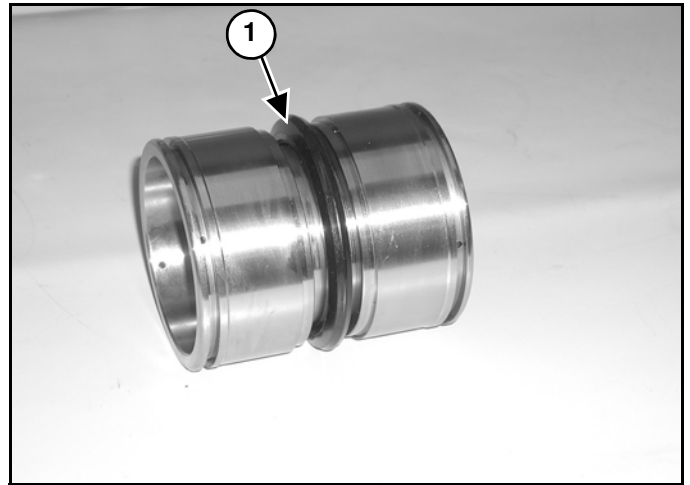

Remove the seal (Item 1) [Figure 20-20-36].

Figure 20-20-37

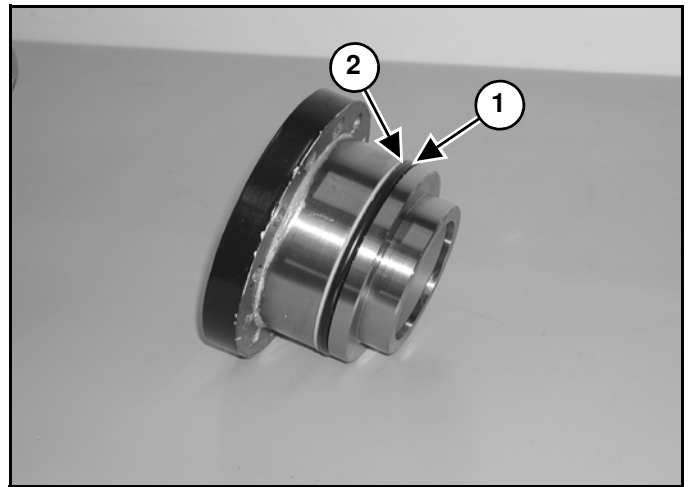

Remove the O-ring (Item 1) and back-up ring (Item 2) [Figure 20-20-37] from the head.

ARM CYLINDER (CONT'D)

Removal And Installation (Cont'd)

Figure 20-21-8

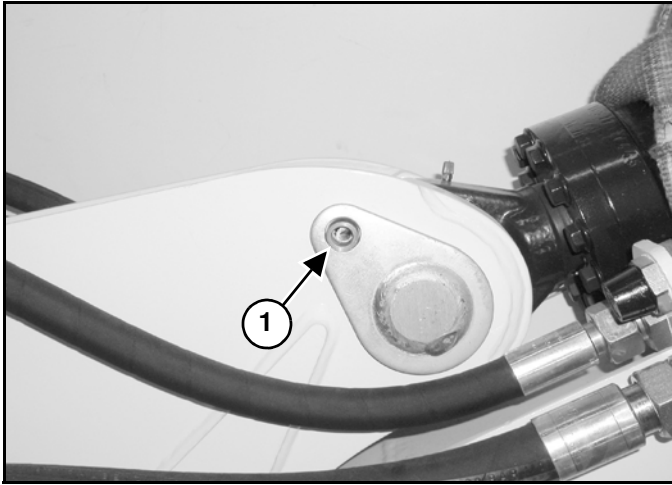

Remove the spacer (Item 1) [Figure 20-21-8].

Figure 20-21-9

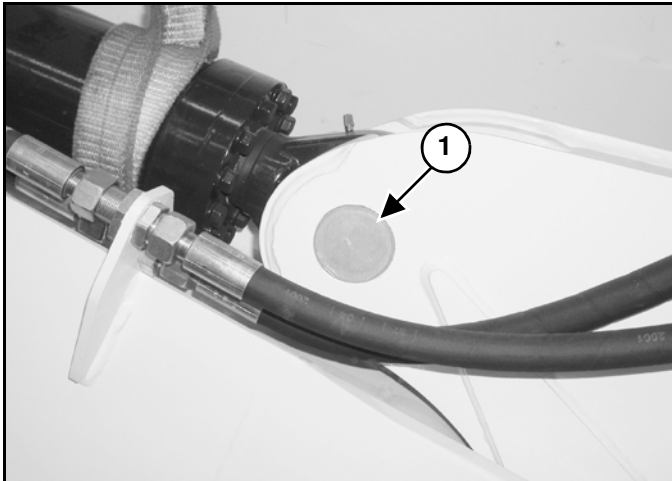

Raise the chain hoist attached to the boom and remove the pin (Item 1) [Figure 20-21-9].

Figure 20-21-10

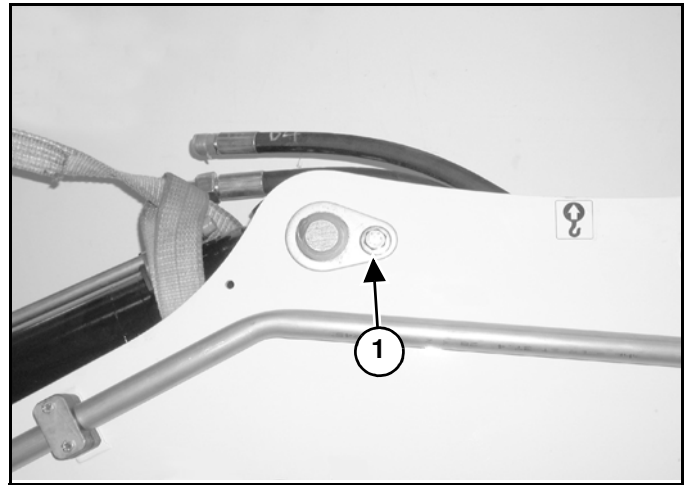

Remove the bolt (Item 1) [Figure 20-21-10] from the base end retaining pin.

Figure 20-21-11

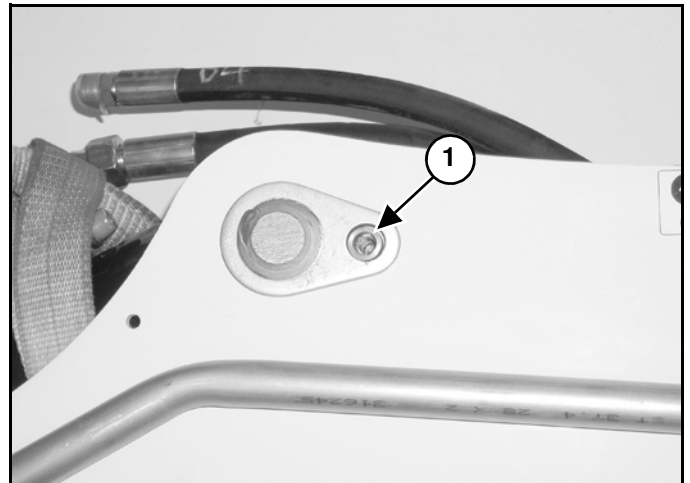

Remove the spacer (Item 1) [Figure 20-21-11].

ARM CYLINDER (CONT'D)

Assembly (Cont'd)

Figure 20-21-42

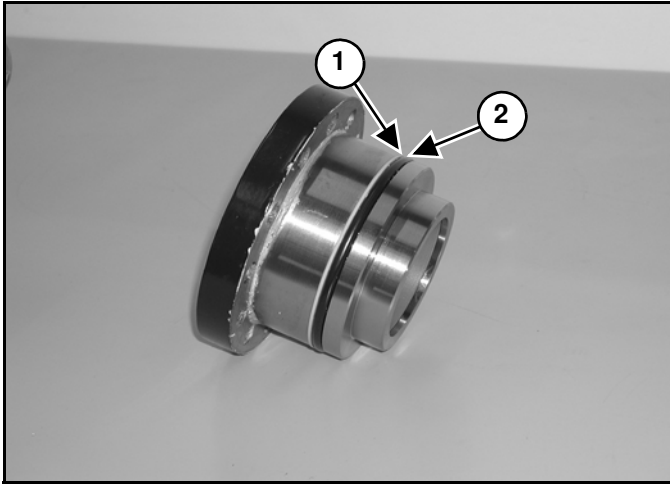

Install the back-up ring (Item 1) and O- ring (Item 2) [Figure 20-21-42] on the head.

Figure 20-21-43

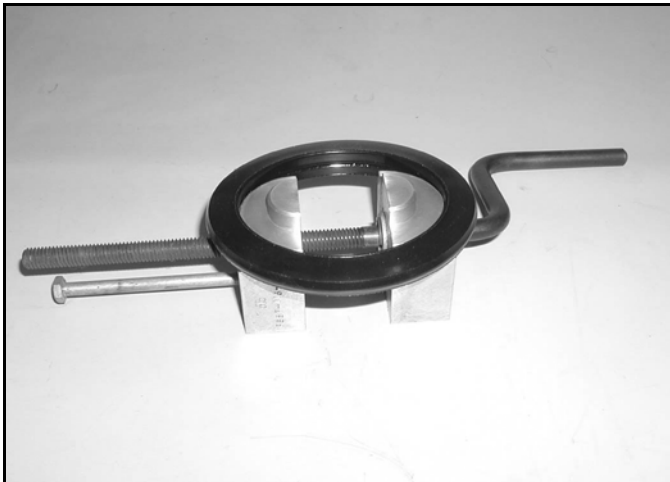

Install the new seal on the tool and slowly stretch it until it fits the piston [Figure 20-21-43].

Allow the seal to stretch for 30 seconds before installing it on the piston.

Figure 20-21-44

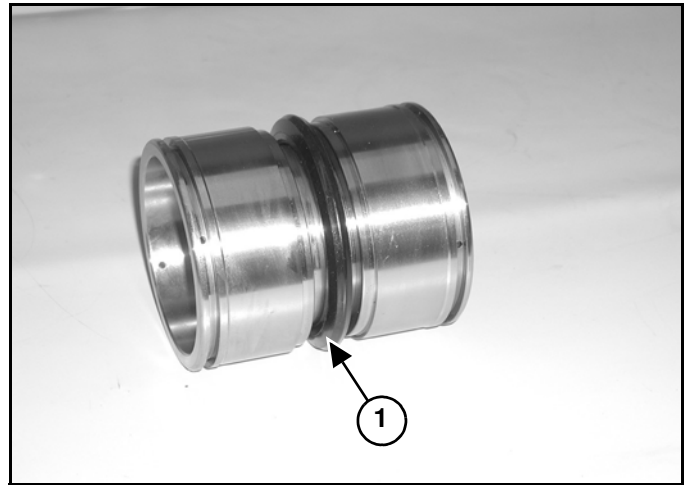

Install the seal (Item 1) [Figure 20-21-44] on the piston.

Figure 20-21-45

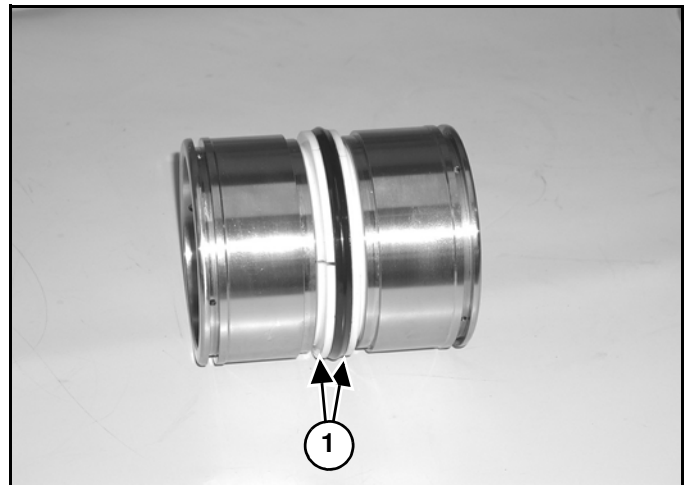

Install the back-up rings (Item 1) [Figure 20-21-45].

Figure 20-21-46

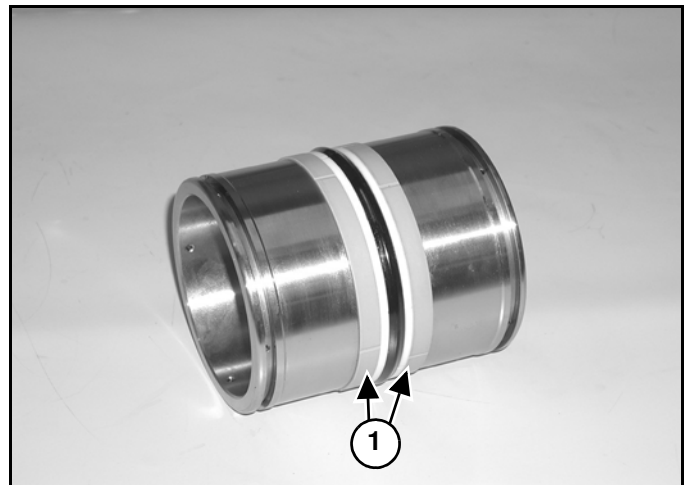

Install the wear rings (Item 1) [Figure 20-21-46].

BOOM OFFSET CYLINDER (CONT'D)

Removal And Installation (Contid)

Figure 20-22-22

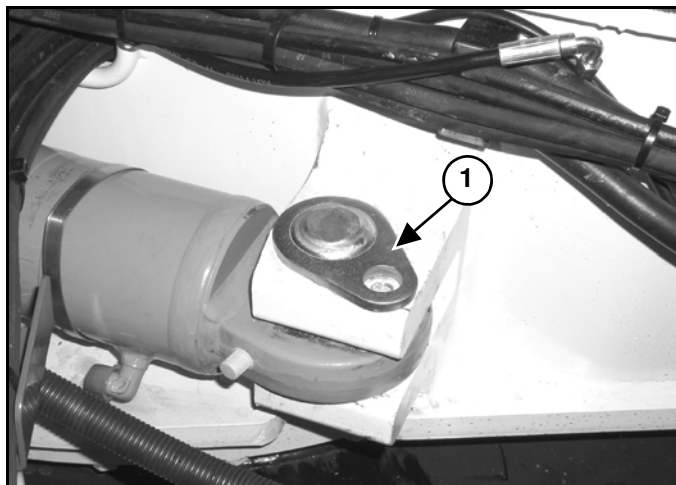

Remove the pin (item 1) [Figure 20-22-22].

Figure 20-22-23

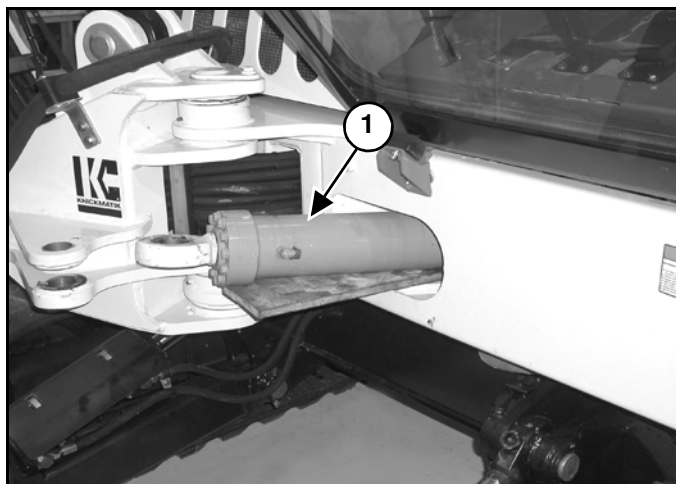

Slide the cylinder (Item 1) [Figure 20-22-23] out the front of the excavator.

BOOM OFFSET CYLINDER (CONT'D)

Assembly (Cont'd)

Figure 20-22-54

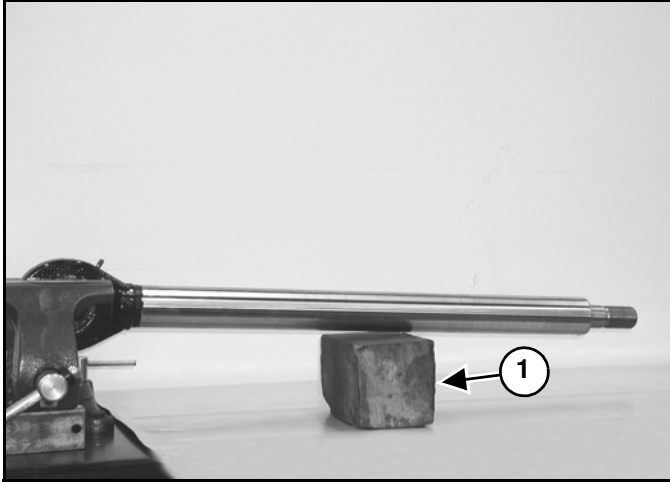

Clamp the rod end in a vise and support the end of the rod with a wood block (Item 1) [Figure 20-22-54]. Use care not to damage the rod.

Figure 20-22-55

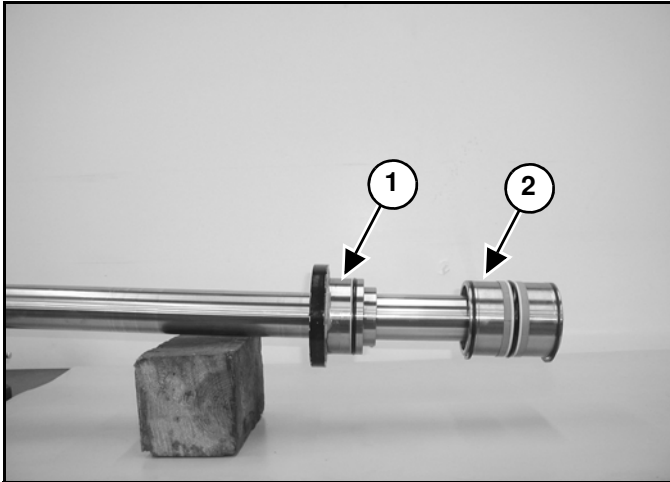

Install the head (Item 1) and piston (Item 2) [Figure 20-22-55].

Figure 20-22-56

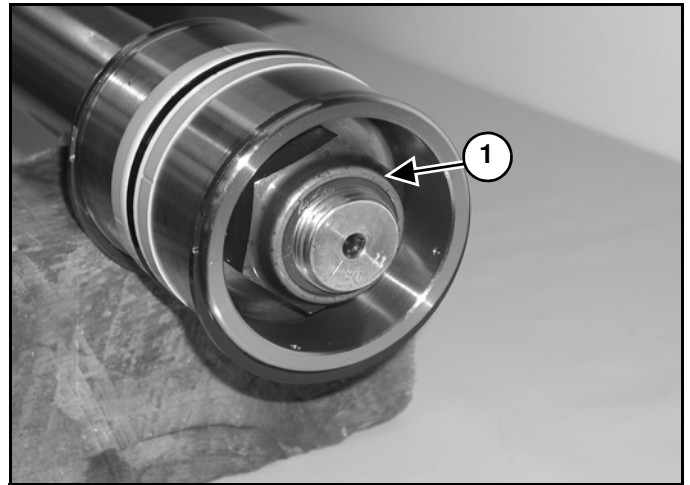

Apply thread lock adhesive (Loctite® 270) to the threads and install the nut (Item 1) [Figure 20-22-56].

Tighten the nut to 1143 ft.-lb. (1550 N·m) torque.

Figure 20-22-57

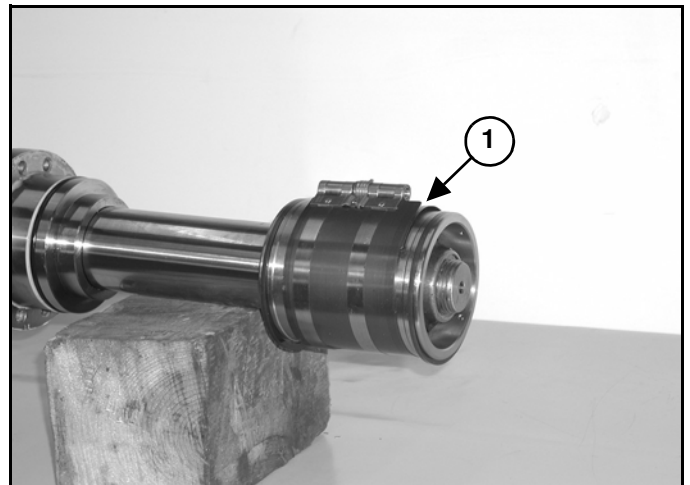

Install a ring compressor on the piston (Item 1) [Figure 20-22-57] and compress the seal to the correct size.

Leave the piston in the compressor for three minutes.

Remove the rod and head assembly from the vise.

BUCKET CYLINDER (CONT'D)

Disassembly (Cont'd)

Figure 20-23-80

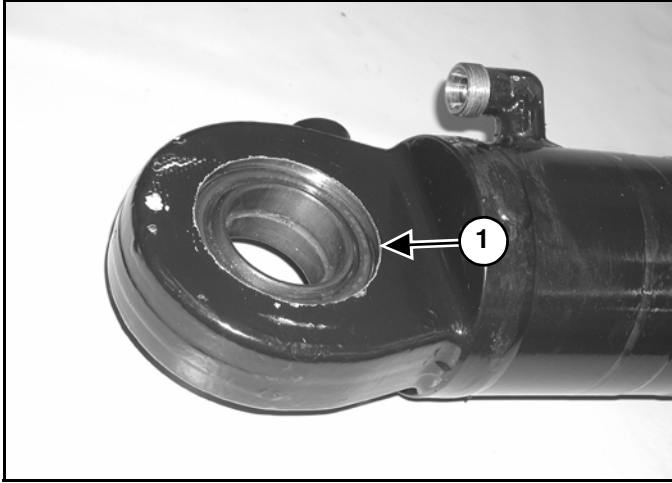

Remove the snap ring (Item 1) [Figure 20-23-80] from the base end of the cylinder.

Figure 20-23-81

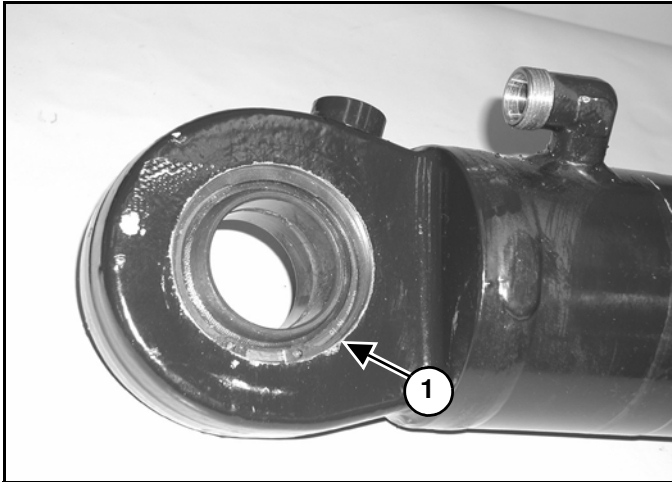

Remove the bearing (Item 1) [Figure 20-23-81].

NOTE: The bearing can only be removed through the snap ring side of the housing.

Figure 20-23-82

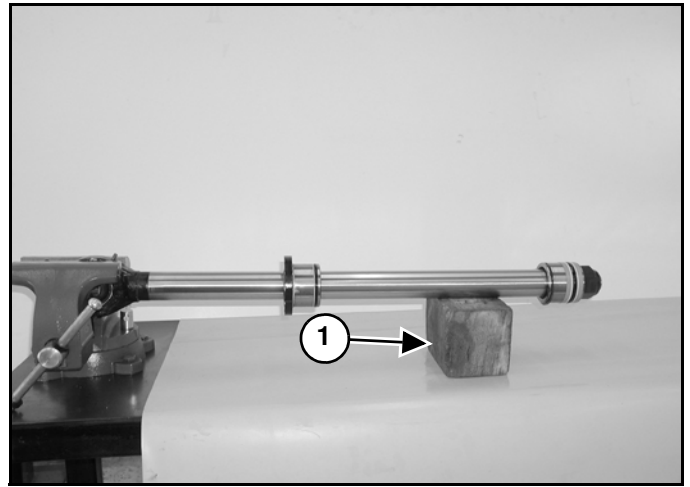

Clamp the rod end in a vise. Support the end of the rod with a wood block (Item 1) [Figure 20-23-82].

Use care not to damage the rod.

Figure 20-23-83

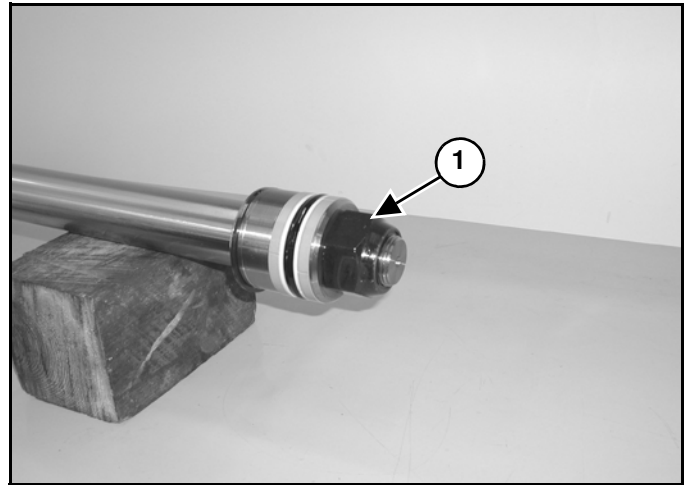

Apply moderate heat to the nut (Item 1) [Figure 20-23-83].

BLADE CYLINDER

Testing

Put the bucket on the ground.

Figure 20-24-1

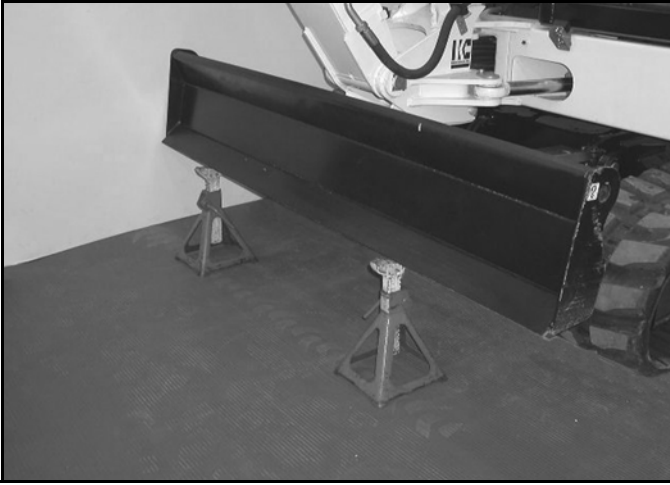

Raise the blade, and support with jack stands **[Figure 20-24-1]**.

Stop the engine.

With the engine off and the key in the run position, move the blade lever to relieve hydraulic pressure.

Figure 20-24-2

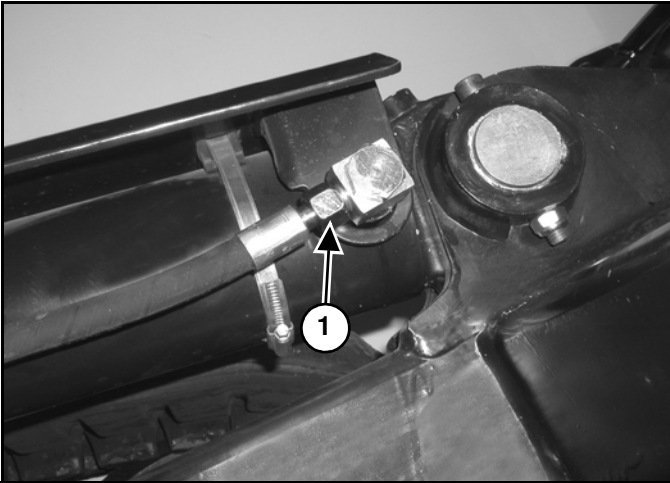

Remove the hydraulic hose (Item 1) **[Figure 20-24-2]** from the base end of the blade cylinders.

Figure 20-24-3

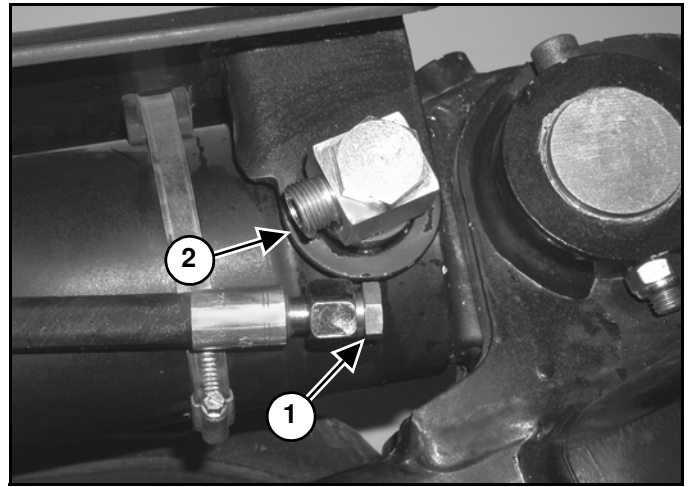

Install a plug (Item 1) **[Figure 20-24-3]** on the hose.

Start the engine and retract the blade cylinders.

If there is any oil leakage from the base end fitting (Item 2) **[Figure 20-24-3]** on the blade cylinders, remove the cylinders for repair or replacement.

BLADE CYLINDER (CONT'D)

Assembly (Cont'd)

Figure 20-24-32

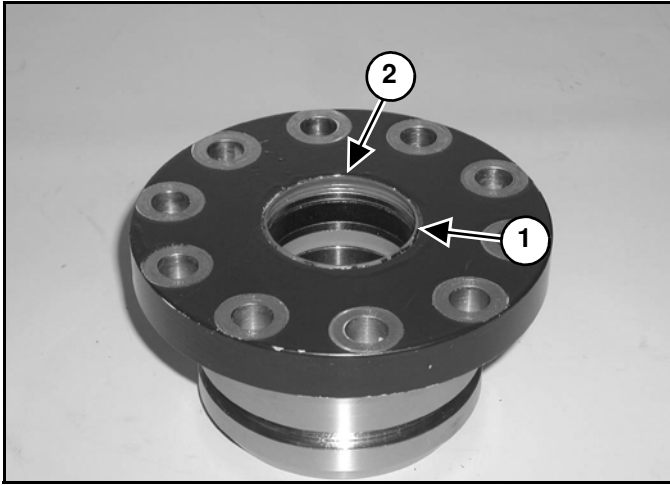

Install the wear ring (Item 1) and wiper (Item 2) [Figure 20-24-32].

Figure 20-24-33

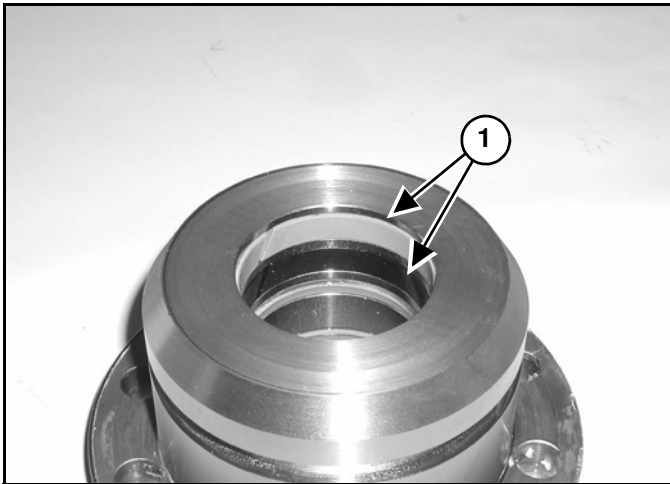

Install the wear rings (Item 1) [Figure 20-24-33].

Figure 20-24-34

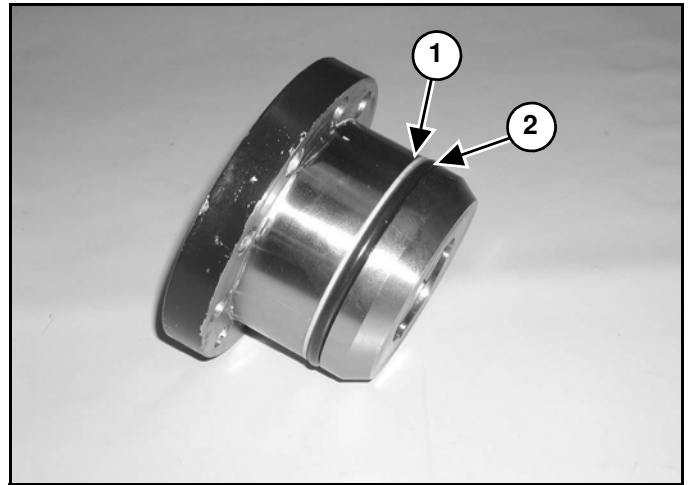

Install the back-up ring (Item 1) and O-ring (Item 2) [Figure 20-24-34].

Figure 20-24-35

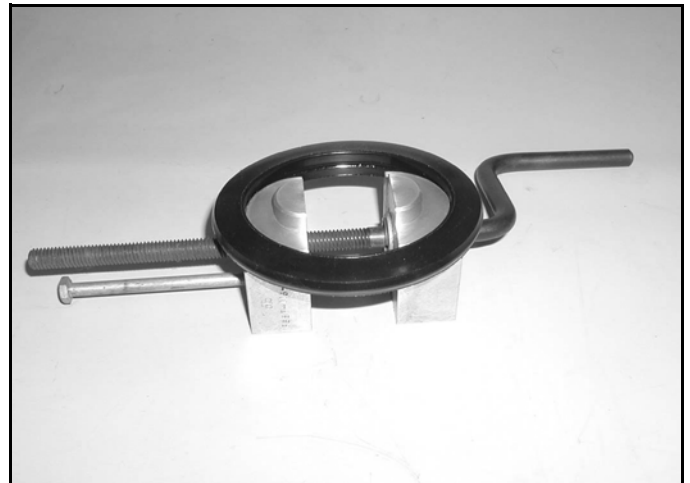

Install the new seal on the tool and slowly stretch it until it fits the piston [Figure 20-24-35].

Allow the seal to stretch for 30 seconds before installing it on the piston.

PRESSURE REDUCING VALVE

Description

The pressure reducing valve lowers system pressure to 508 PSI (35 bar) for joystick operation.

Testing

Open the rear cover.

Figure 20-33-1

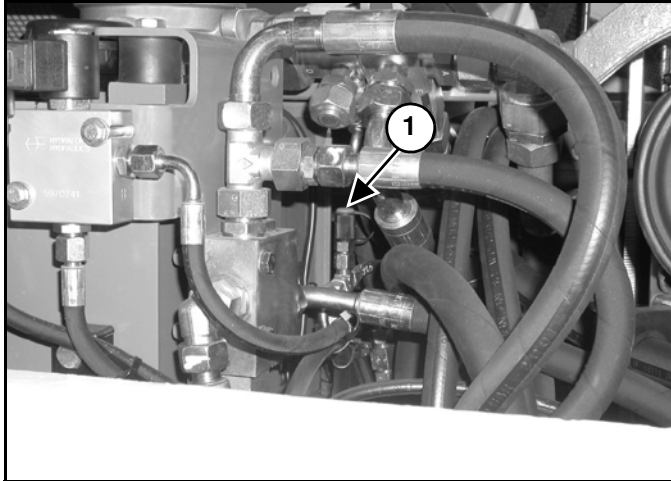

Install a 1000 PSI (69 bar) pressure gauge on the test coupler (Item 1) [Figure 20-33-1].

Start the engine.

Move the speed control lever to the high speed position.

Lower the left console.

Raise the boom and fully extend the bucket cylinder.

Record the pressure.

Figure 20-33-2

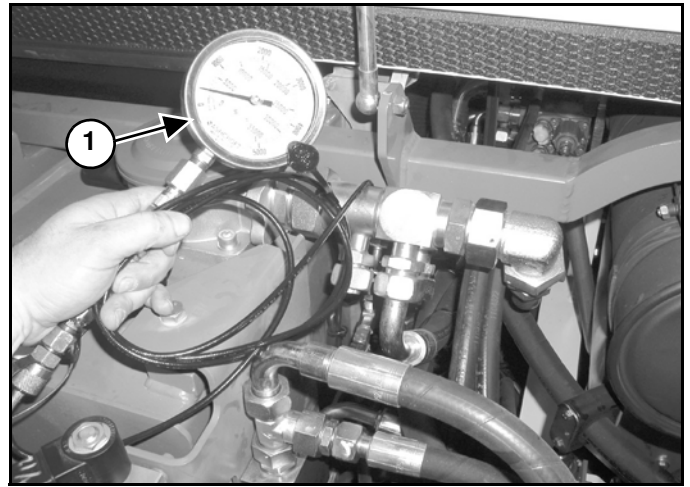

The pressure at the gauge (Item 1) [Figure 20-33-2] should be 508 PSI (35 bar).

SIX SPOOL HYDRAULIC CONTROL VALVE

Removal And Installation

Remove the right side cover. (See RIGHT SIDE COVER on Page 40-160-1.)

Drain the hydraulic reservoir. (See Replacing The Hydraulic Oil on Page 10-100-2.)

Figure 20-40-1

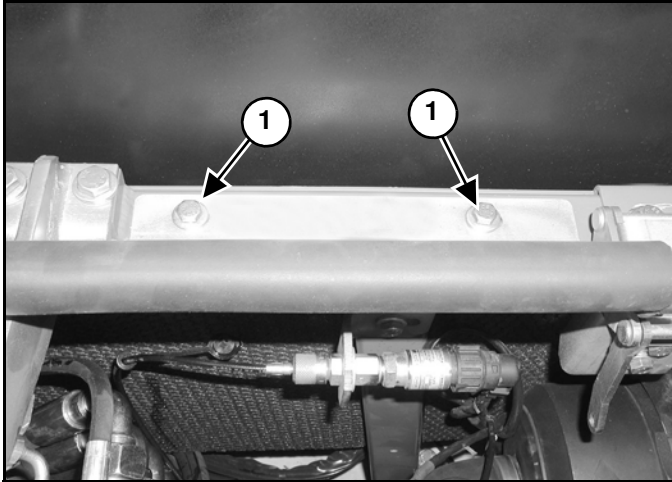
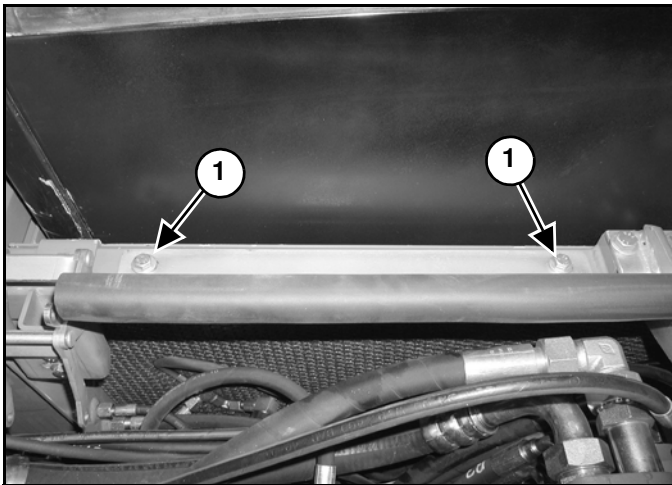
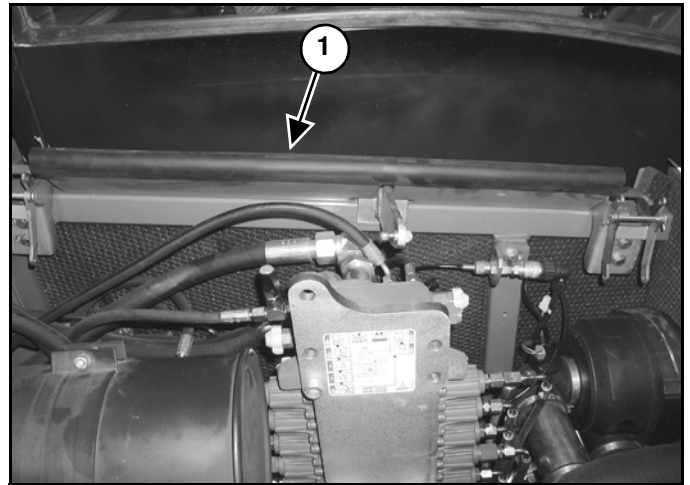

Figure 20-40-2



Remove the 4 bolts (Item 1) [Figure 20-40-1] & [Figure 20-40-2] from the shield.

Figure 20-40-3



Remove the shield (Item 1) [Figure 20-40-3].

Figure 20-40-4

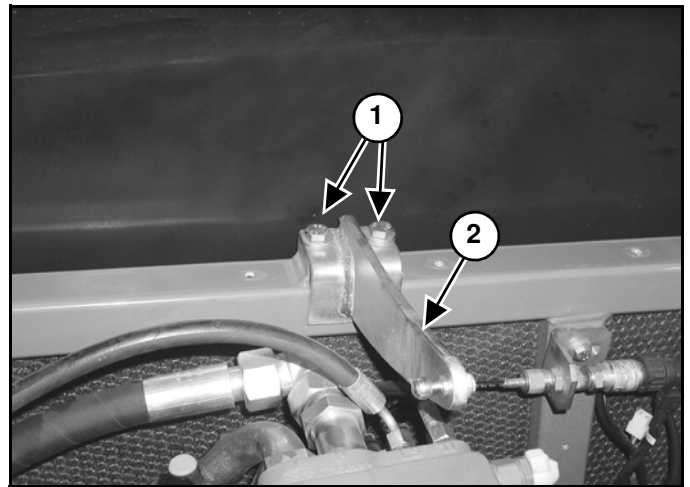

Remove the 2 bolts (Item 1) [Figure 20-40-4].

Remove the gas strut mount (Item 2) [Figure 20-40-4].

SIX SPOOL HYDRAULIC CONTROL VALVE (CONT'D)

Left Travel and Right Travel Valve Section Disassembly And Assembly (Cont'd)

Figure 20-40-34

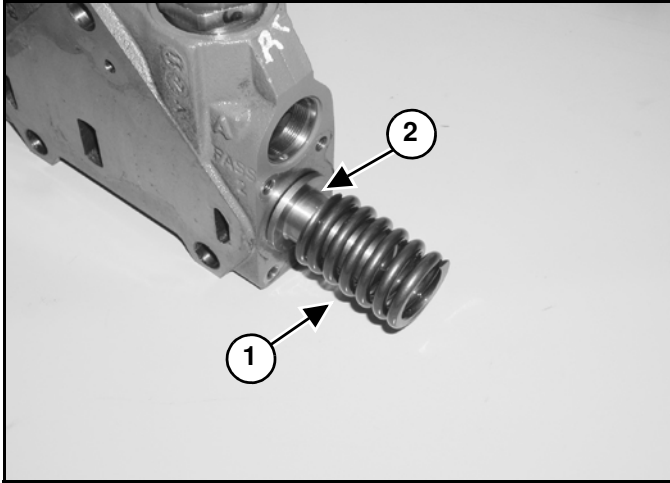

Remove the centering spring (Item 1) [Figure 20-40-34] from both ends.

Remove the spring seat (Item 2) [Figure 20-40-34] from both ends.

Figure 20-40-35

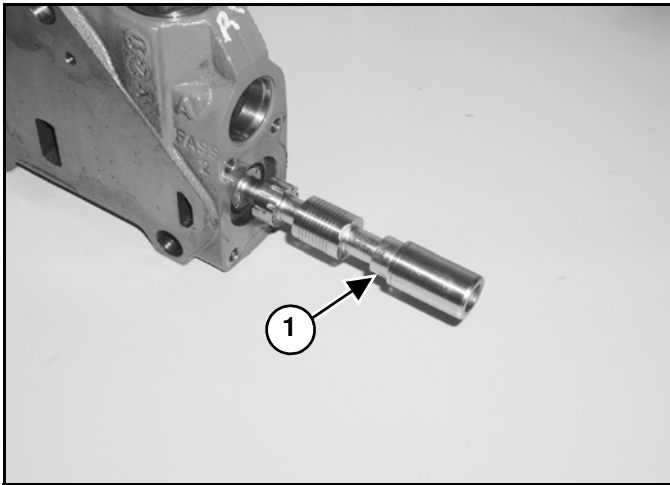

Remove the spool (Item 1) [Figure 20-40-35].

Figure 20-40-36

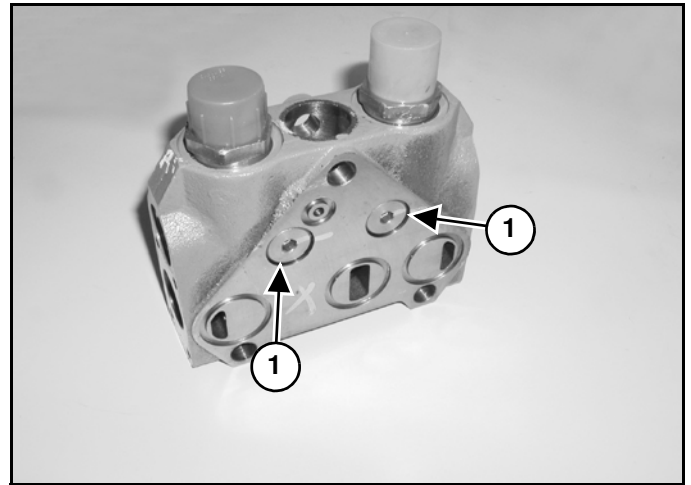

Remove the plugs (Item 1) [Figure 20-40-36].

Figure 20-40-37

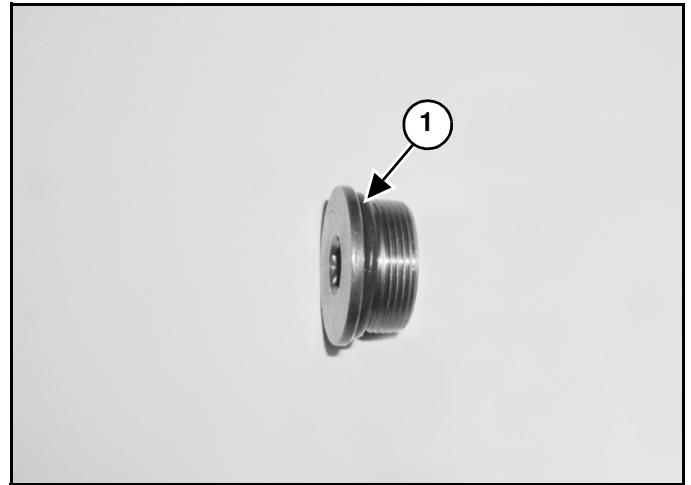

Remove the O-ring (Item 1) [Figure 20-40-37].

THREE SPOOL HYDRAULIC CONTROL VALVE (CONT'D)

Parts Identification

1. Swing/Inlet Section
2. Blade Section
3. Boom Offset Section
4. Outlet Section
5. Load Check Valve
6. Main Relief Valve

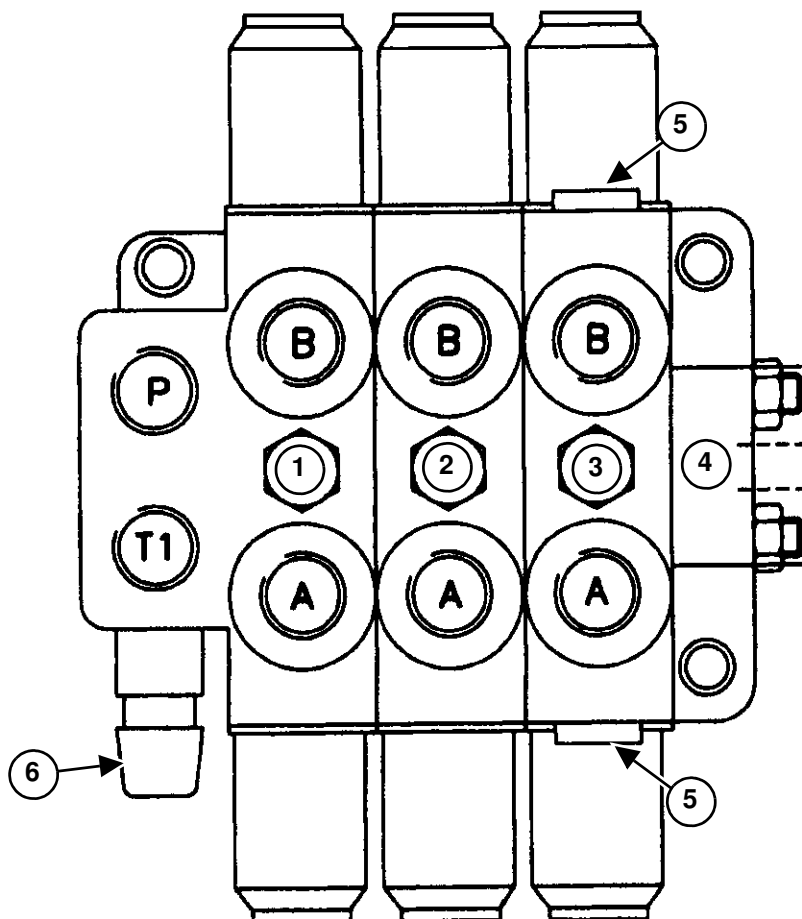

**THREE SPOOL HYDRAULIC CONTROL VALVE
(CONTÍD)**

**Inlet/Upperstructure Swing Valve Section
Disassembly And Assembly (Contíd)**

Figure 20-41-38

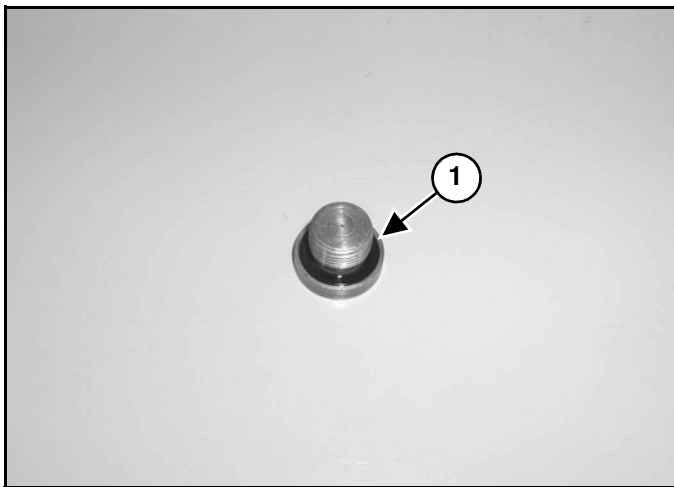

Remove the O-ring (Item 1) [Figure 20-41-38].

HYDRAULIC PISTON PUMP

Pump Testing (Contid)

Torque Limiter Adjustment

Figure 20-52-14

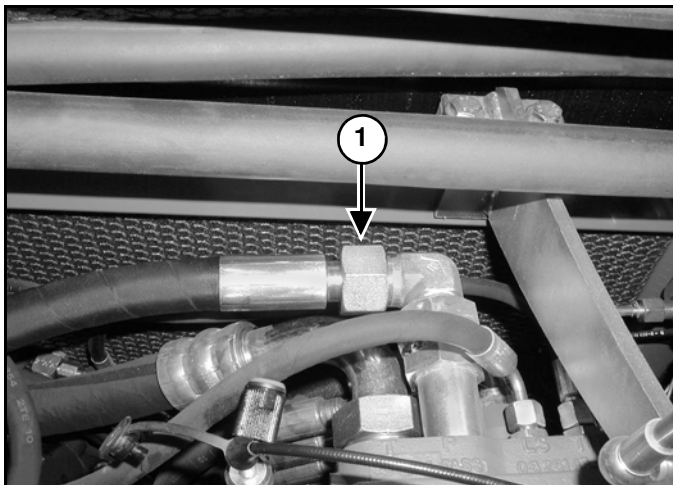

Remove the inlet hose (Item 1) [Figure 20-52-14] from the hydraulic control valve.

Figure 20-52-15

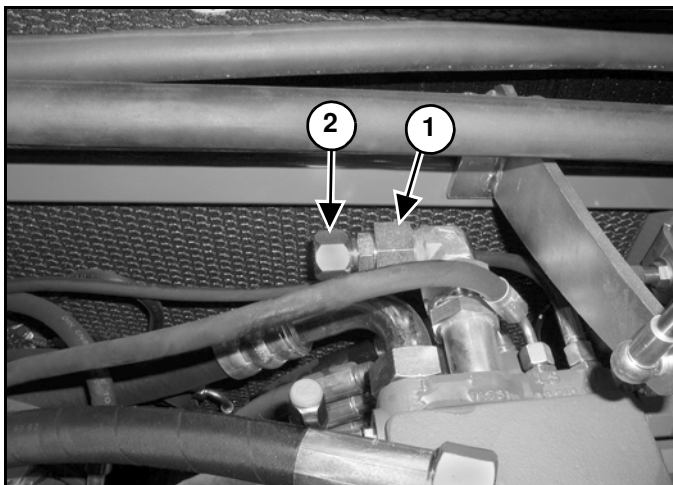

Install the adapter (Item 1) and cap (Item 2) [Figure 20-52-15].

Figure 20-52-16

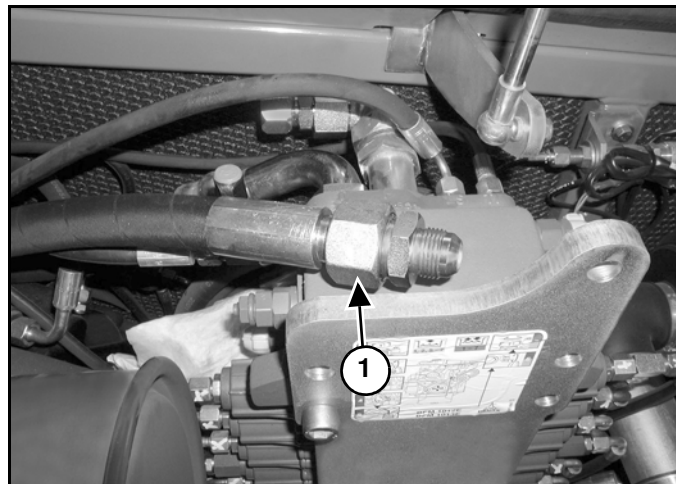

Install the adapter (Item 1) [Figure 20-52-16] on the inlet hose.

Figure 20-52-17

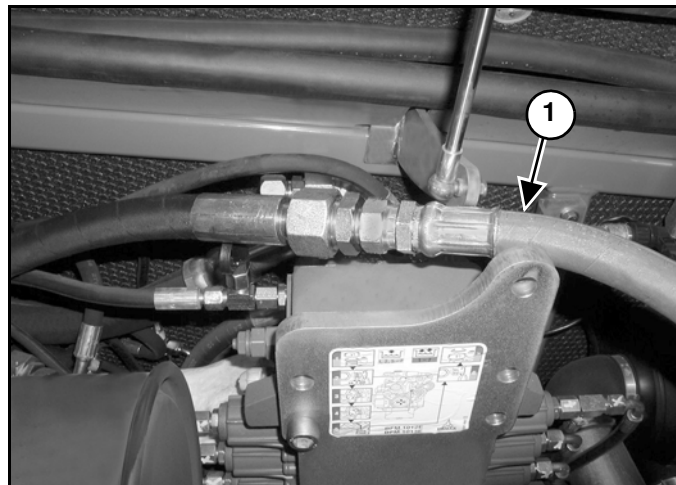

Connect the inlet hose to the **INLET** side of the hydraulic tester (Item 1) [Figure 20-52-17].

HYDRAULIC PISTON PUMP

Torque Limiter Valve Disassembly (Contid)

Figure 20-52-45

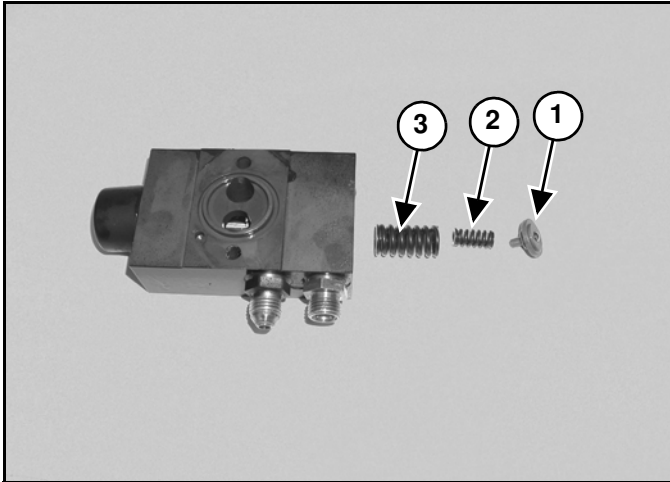

Remove the spring seat (Item 1). Remove the two springs (Item 2 & 3) [Figure 20-52-45].

Figure 20-52-46

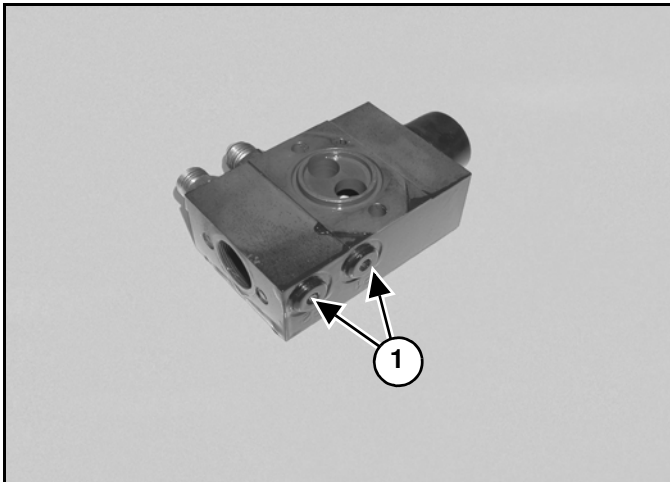

Remove the plugs (Items) [Figure 20-52-46].

Figure 20-52-47

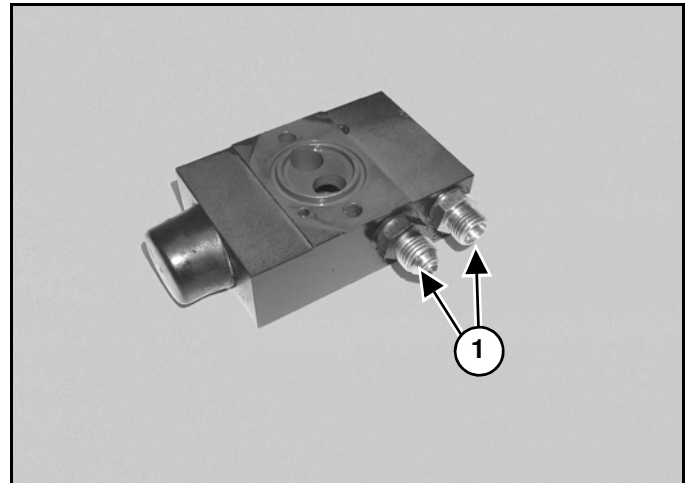

Remove the fittings (Item 1) [Figure 20-52-47].

Figure 20-52-48

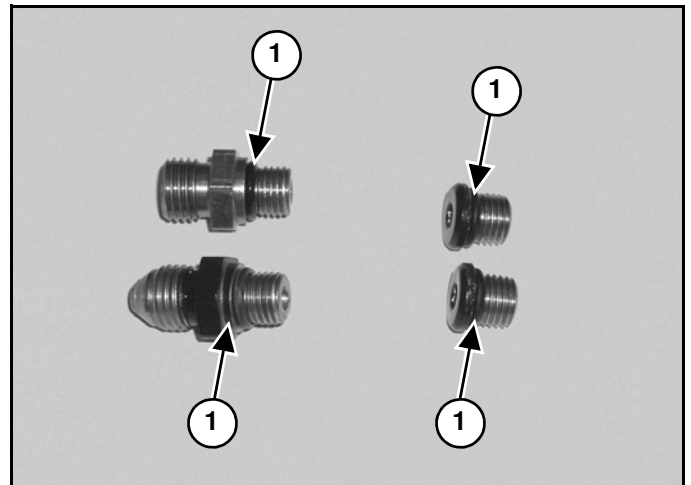

Remove the O-rings (Item 1) [Figure 20-52-48] from the fittings and plugs.

The following procedures are only used if the adjustment assembly is removed.

NOTE: If the adjustment assembly is removed and/or disassembled, the torque limiter must be tested and adjusted after the pump assembly is installed in the machine. See "Initial Torque Limiter Valve Setting" on page 26.)

HYDRAULIC PISTON PUMP

Pump Control Removal And Installation

Figure 20-52-72

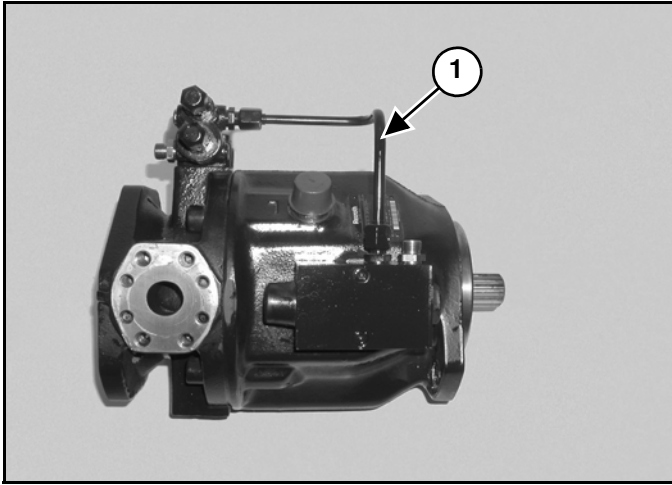

Mark the tubeline (Item 1) [Figure 20-52-72] for correct assembly.

Loosen and remove the tubeline (Item 1) [Figure 20-52-72] from the pump control and torque limiter valve.

Figure 20-52-73

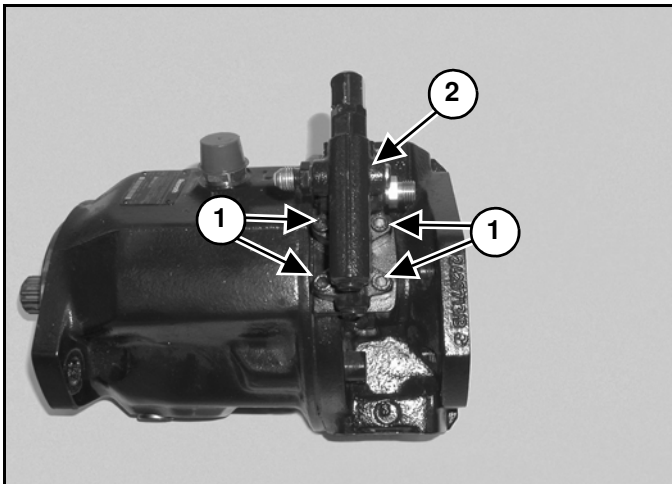

Remove the 4 bolts (Item 1) and remove the pump control (Item 2) [Figure 20-52-73] from the hydraulic piston pump.

Installation: Tighten to 10 ft.-lb. and (13 N·m) torque.

HYDRAULIC PISTON PUMP

Disassembly (Cont'd)

Figure 20-52-104

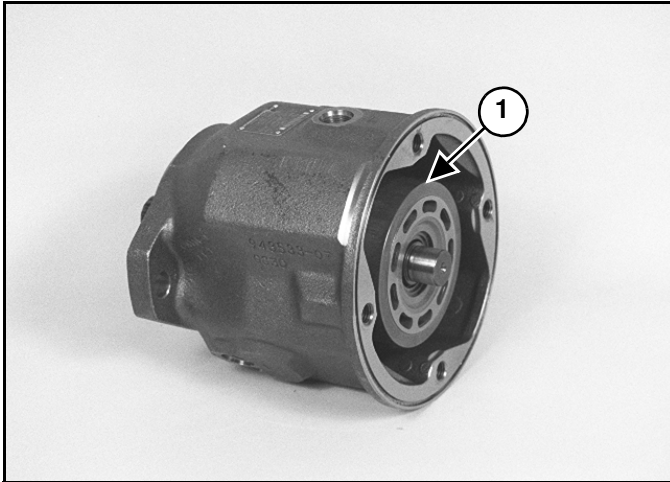

Lay the pump assembly on its side and remove the rotary group, cradle, and shaft (Item 1) [Figure 20-52-104] from the housing.

Figure 20-52-105

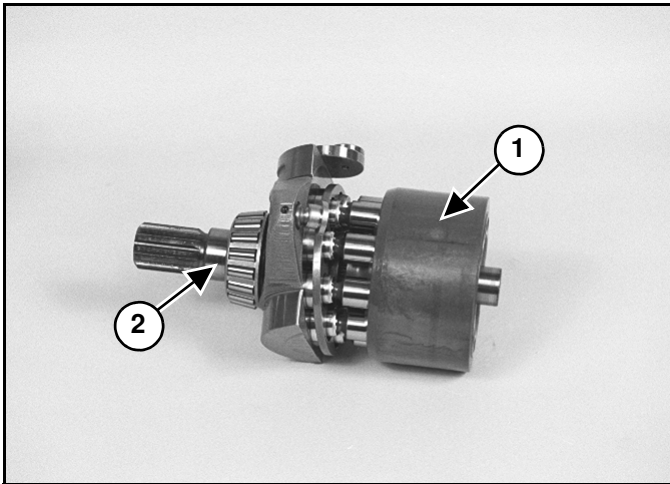

Slide the rotary group (Item 1) from the shaft assembly (Item 2) [Figure 20-52-105].

NOTE: It is NOT important that the pistons are installed in their original positions.

NOTE: Check that there are no scratches or metal deposits on the sliding surface. (Pistons must be replaced in sets).

Figure 20-52-106

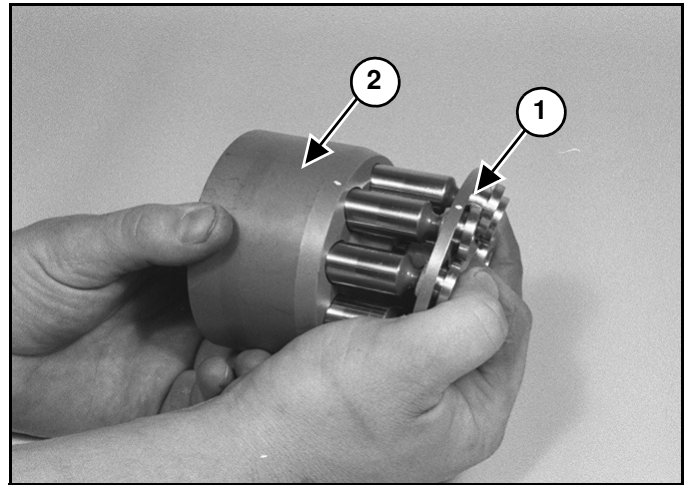

Remove the retainer plate and pistons (Item 1) from the cylinder block (Item 2) [Figure 20-52-106].

NOTE: The following procedure shown is to disassemble the rotating group for inspection only. The rotating group parts can not be ordered separately and must be ordered as an assembly.

Figure 20-52-107

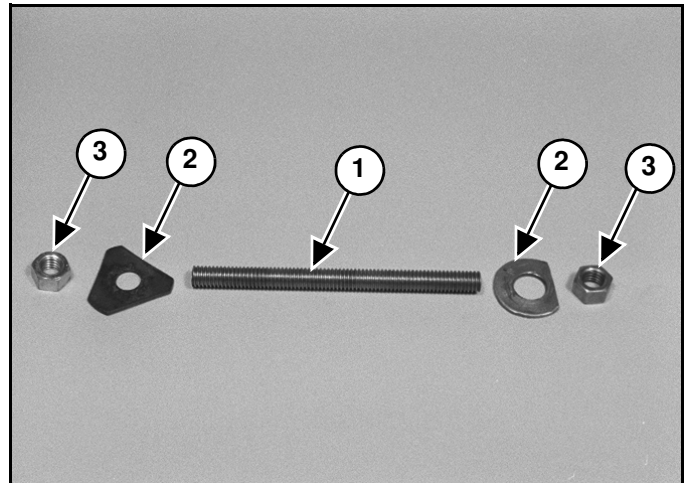

To remove the spring from inside the cylinder block, use a threaded rod (or bolt) (Item 1) two trimmed washers (Item 2) and two nuts (Item 3) [Figure 20-52-107].

HYDRAULIC PISTON PUMP

Assembly (Cont'd)

Figure 20-52-139

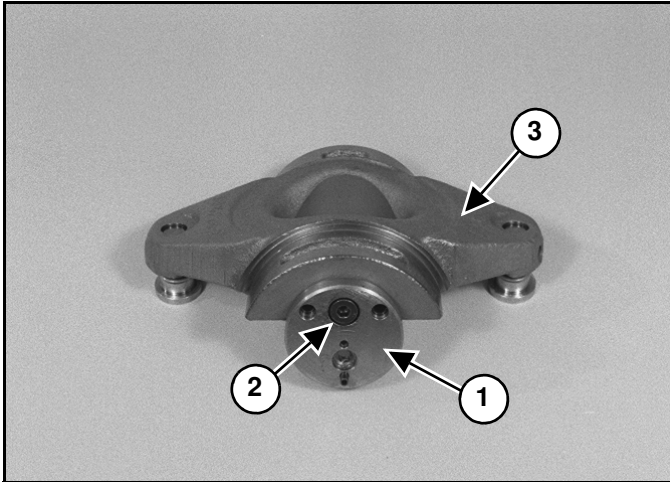

Apply Loctite® 241 and install the torque limiter plate (Item 1) and bolt (Item 2) on the swash plate (Item 3) [Figure 20-52-139].

Figure 20-52-140

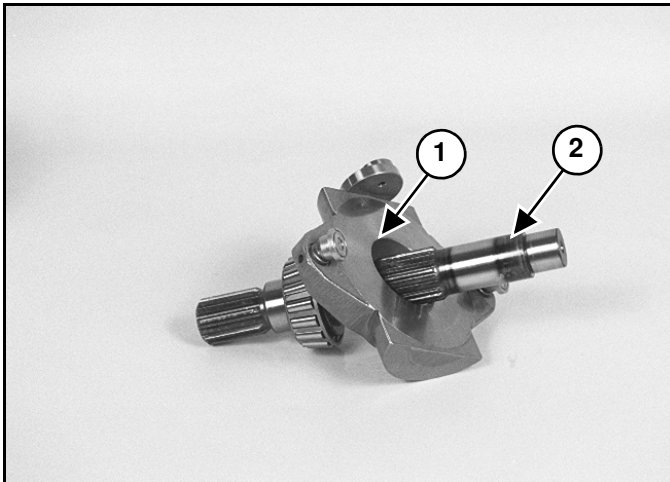

Install the cradle (Item 1) on the shaft (Item 2) [Figure 20-52-140].

Figure 20-52-141

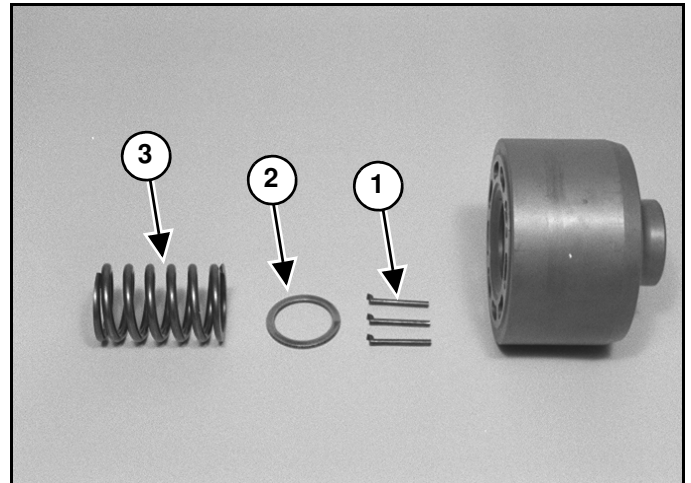

Apply clean grease to the three pins (Item 1) [Figure 20-52-141] and install them in the appropriate groove.

Install the washer (Item 2) and the spring (Item 3) [Figure 20-52-141].

NOTE: If the rotating group is damaged, the parts can not be ordered separately and must be order as an assembly.

Figure 20-52-142

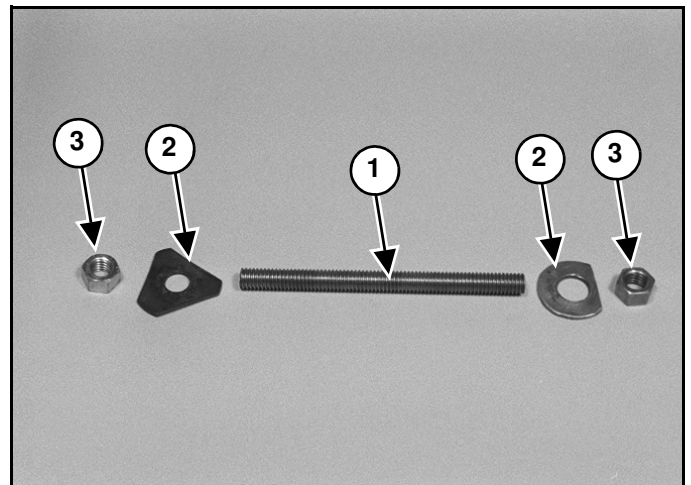

To compress the spring inside the cylinder block, use a threaded rod (or bolt) (Item 1), 2 trimmed washers (Item 2) and 2 nuts (Item 3) [Figure 20-52-142].

HYDRAULIC GEAR PUMP

Disassembly (Cont'd)

Figure 20-53-9

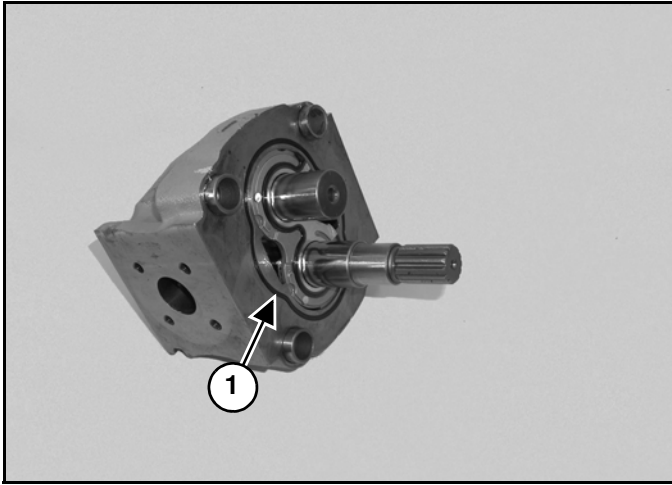

Remove the seal (Item 1) [Figure 20-53-9].

Figure 20-53-10

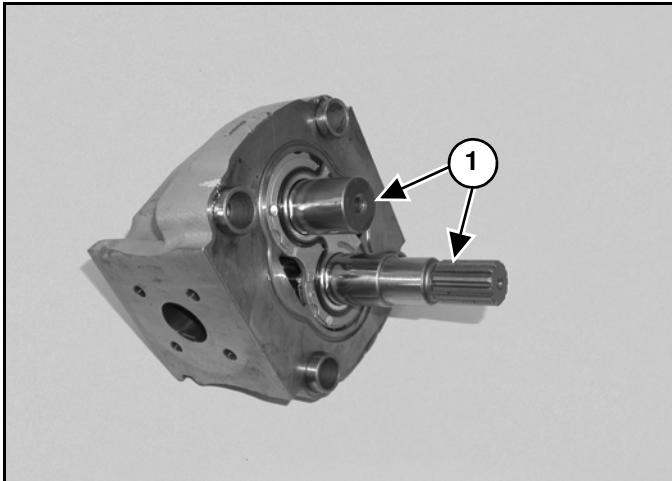

Remove the bearing/gear assembly (Item 1) [Figure 20-53-10].

Figure 20-53-11

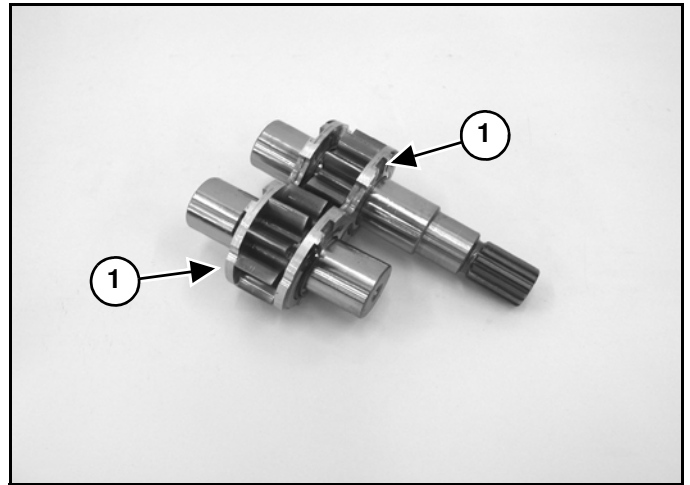

Remove the bearings (Item 1) [Figure 20-53-11] from the gears.

Figure 20-53-12

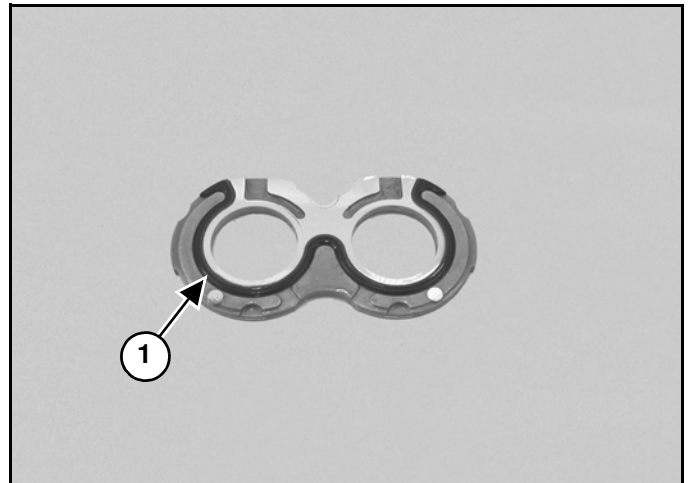

Remove the seal (Item 1) [Figure 20-53-12] and back-up ring from the bearings.

TRAVEL MOTOR (CONT'D)

Disassembly

Drain the travel motor oil. (See Draining The Travel Motor on Page 10-120-1.)

Figure 20-70-4

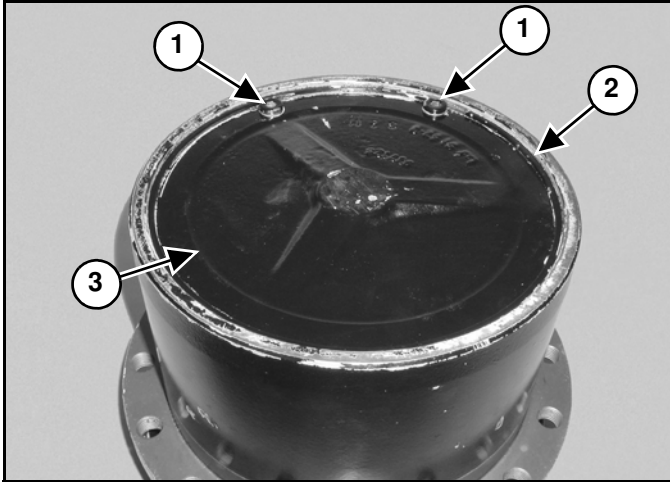

Remove the drain plugs (Item 1), snap ring (Item 2) and cover (Item 3) [Figure 20-70-4].

Figure 20-70-5

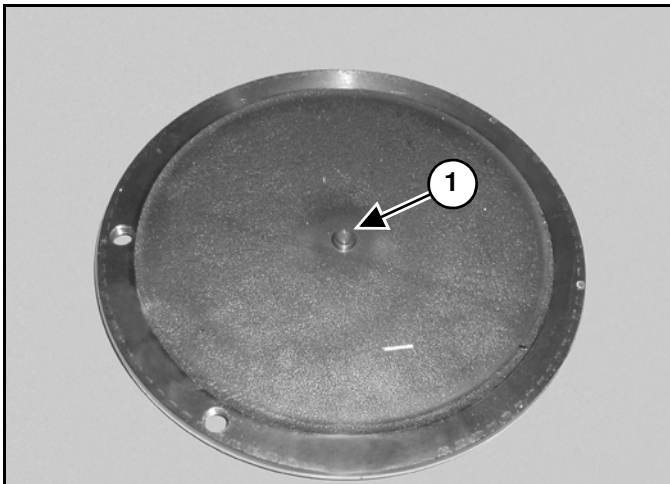

Drill a hole in the center of the bushing (Item 1) [Figure 20-70-5] using a number 3 drill bit.

Thread the hole using a 1/4 x 28 inch N.F. tap.

Install a 1/4 x 28 inch bolt in the bushing, and pull the bushing out.

Figure 20-70-6

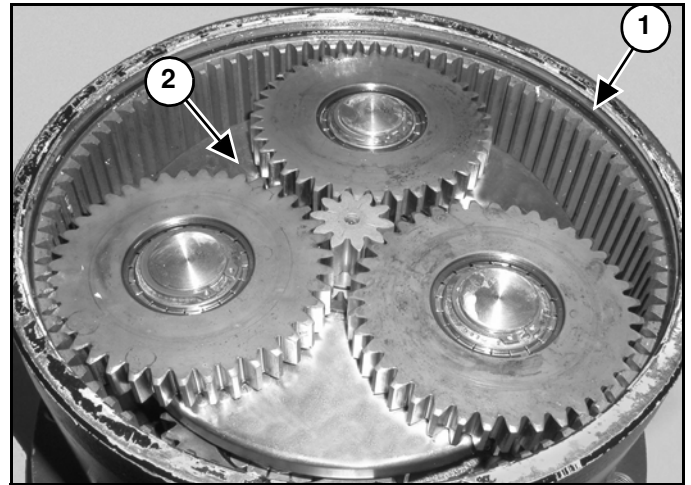

Remove the O-ring (Item 1) and planetary carrier (Item 2) [Figure 20-70-6].

Place the carrier in a vice equipped with padded jaws.

Figure 20-70-7

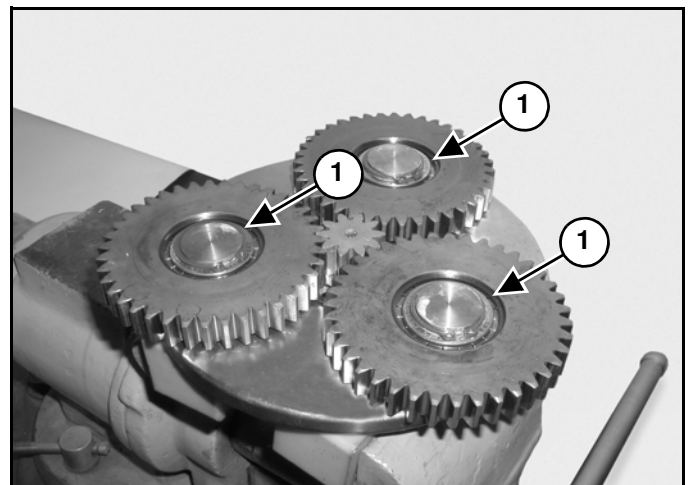

Remove the snap rings (Item 1) [Figure 20-70-7].

TRAVEL MOTOR (CONTÍD)

Disassembly (Contíd)

Figure 20-70-44

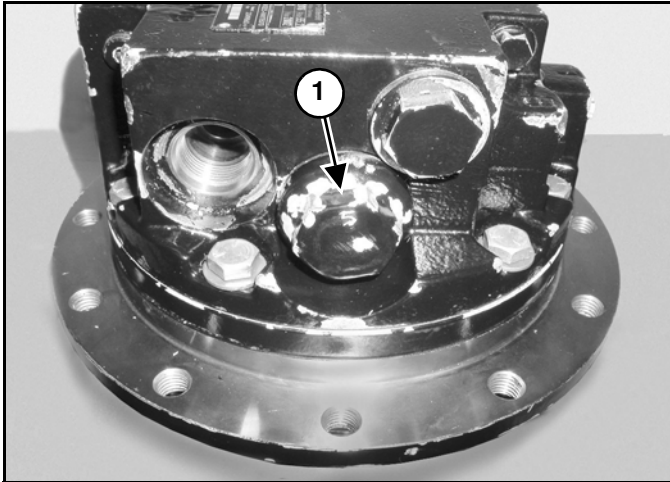

Remove the plug (Item 1) [Figure 20-70-44].

Figure 20-70-45

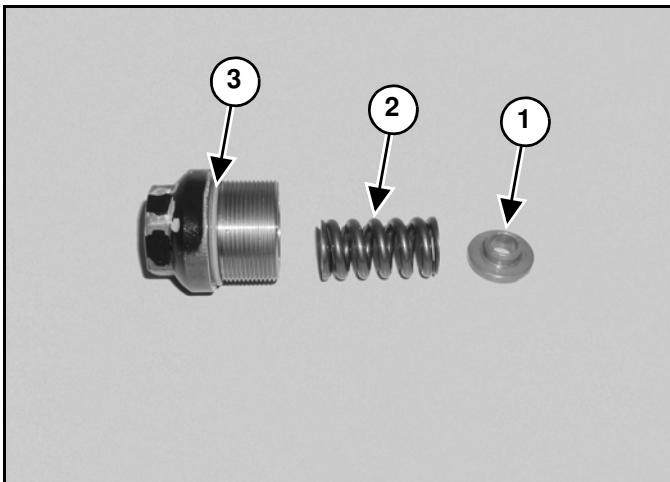

Remove the spring seat (Item 1), spring (Item 2) and O-ring (Item 3) [Figure 20-70-45].

Figure 20-70-46

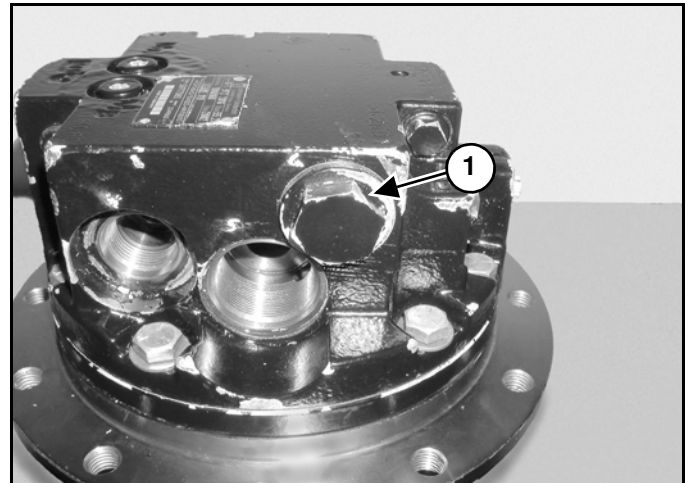

Remove the plug (Item 1) [Figure 20-70-46].

Figure 20-70-47

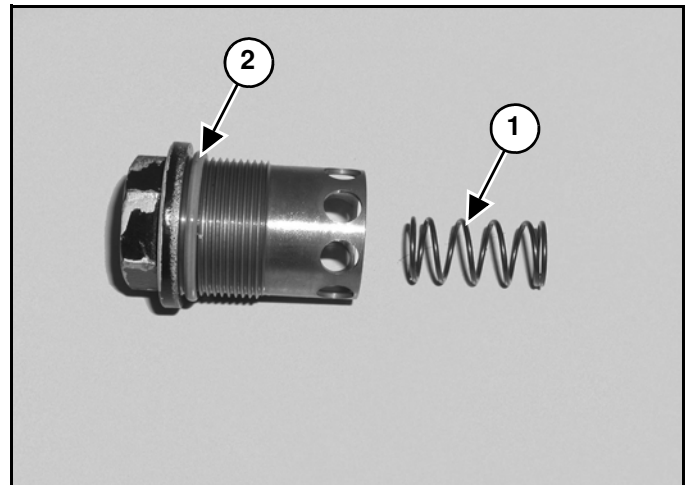

Remove the spring (Item 1) and O-ring (Item 2) [Figure 20-70-47].

TRAVEL MOTOR (CONT'D)

Assembly (Cont'd)

Figure 20-70-83

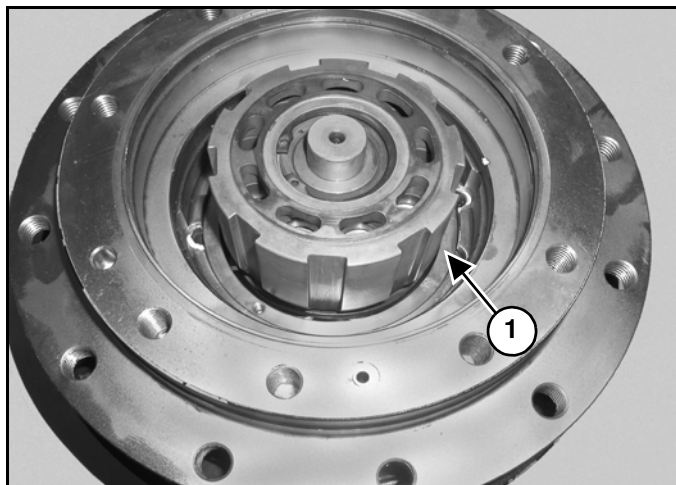

Install the brake disc stop (Item 1) [Figure 20-70-83].

Figure 20-70-84

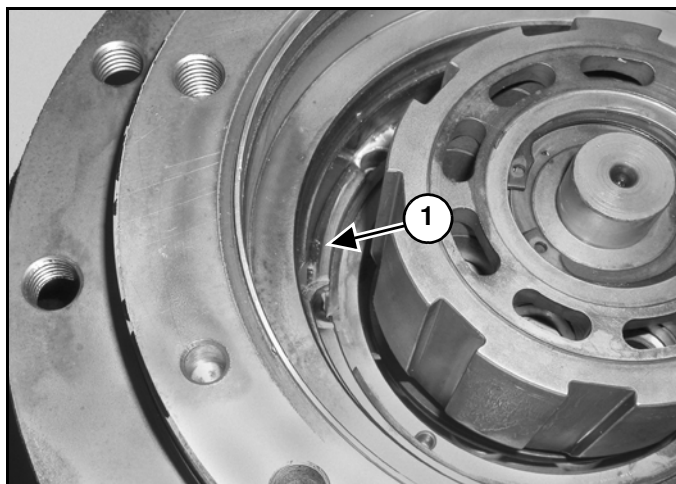

Install the snap ring (Item 1) [Figure 20-70-84].

Figure 20-70-85

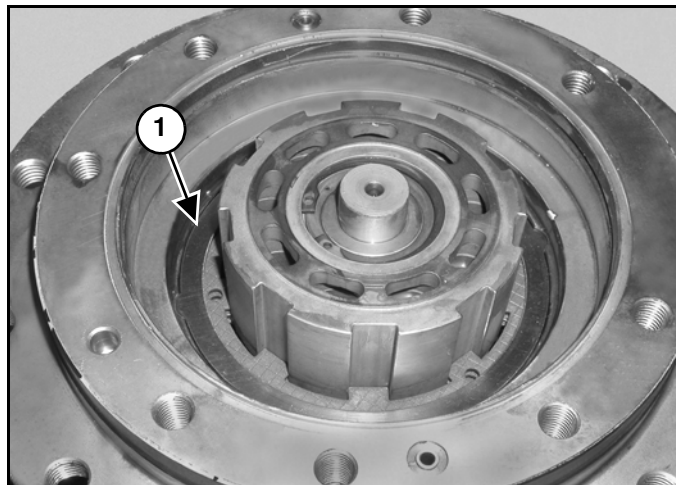

Install the brake discs (Item 1) [Figure 20-70-85].

Figure 20-70-86

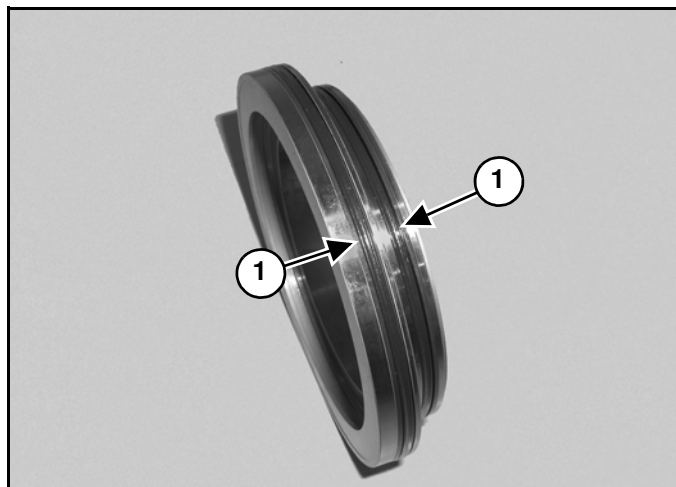

Install the quad rings (Item 1) [Figure 20-70-86].

TRAVEL MOTOR (CONT'D)

Assembly (Cont'd)

Figure 20-70-123

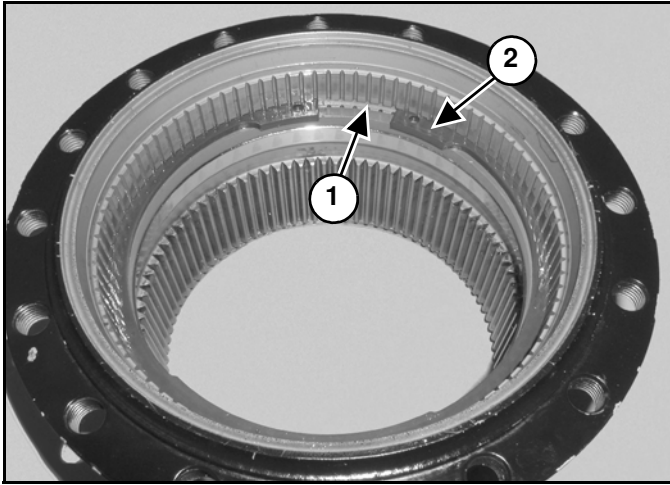

Install the spacer (Item 1) and snap ring (Item 2) [Figure 20-70-123].

Figure 20-70-124

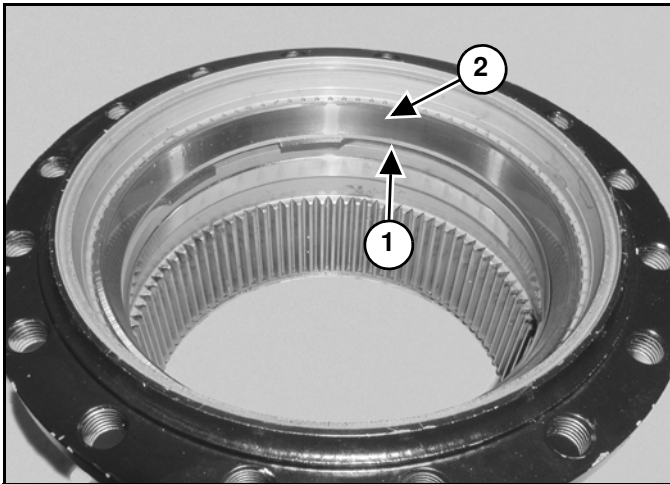

Install the spacer (Item 1) and bearing race (Item 2) [Figure 20-70-124].

Figure 20-70-125

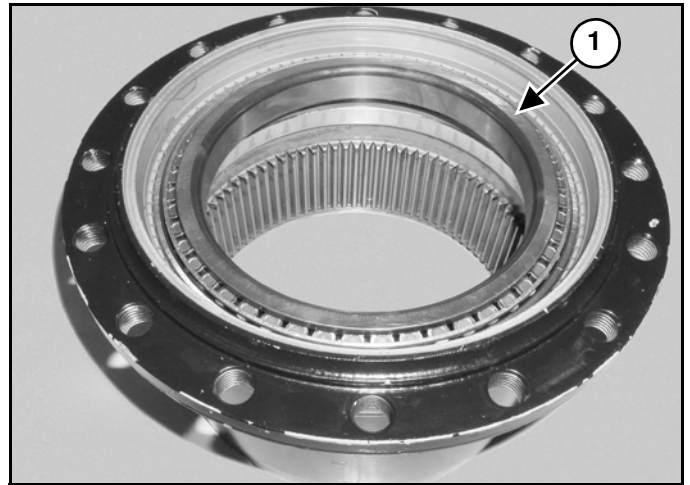

Install the bearing (Item 1) [Figure 20-70-125].

Figure 20-70-126

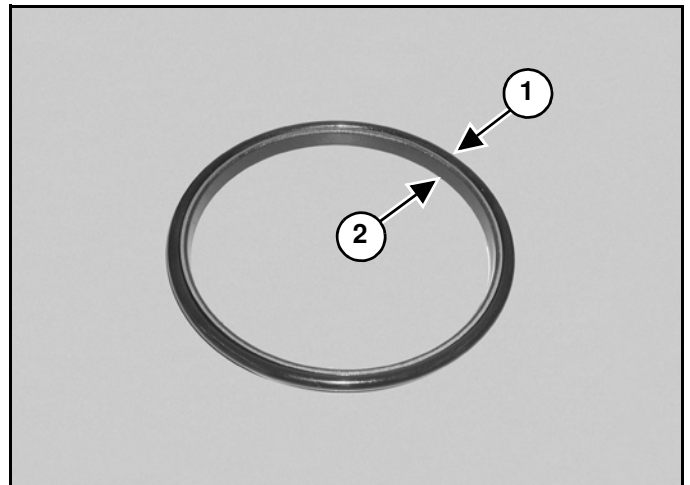

Install the O-ring (Item 1) on both seal rings (Item 2) [Figure 20-70-126].

NOTE: Inspect the seal ring for burrs before installing the O-ring. Install the O-ring making sure it is not twisted. To remove any twists, gently pull a section of the O-ring and let it snap back.

The O-ring, seal ring, hub assembly, and bearing carrier must be clean and free of any dust, oil film, or foreign matter.

The O-ring and seal ring assembly has to be lubricated with rubbing alcohol, so the O-ring will slip past the housing retaining ring and seal uniformly in the housing radius.

Dip the O-ring and seal ring assembly in a pan of alcohol.

SWIVEL JOINT (CONT'D)

Disassembly And Assembly (Cont'd)

Figure 20-80-13

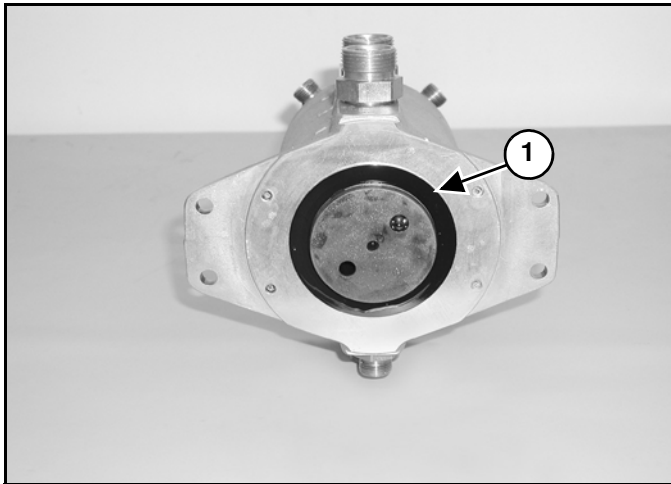

Remove the washer (Item 1) [Figure 20-80-13].

Figure 20-80-14

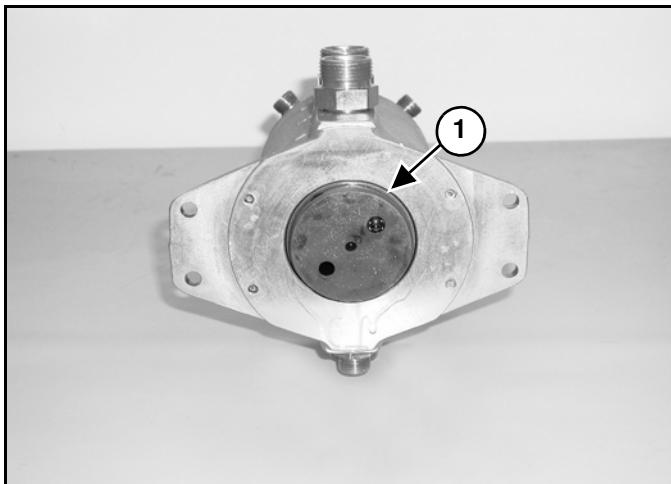

With a soft faced hammer drive the rotor (Item 1) [Figure 20-80-14] from the housing.

Figure 20-80-15

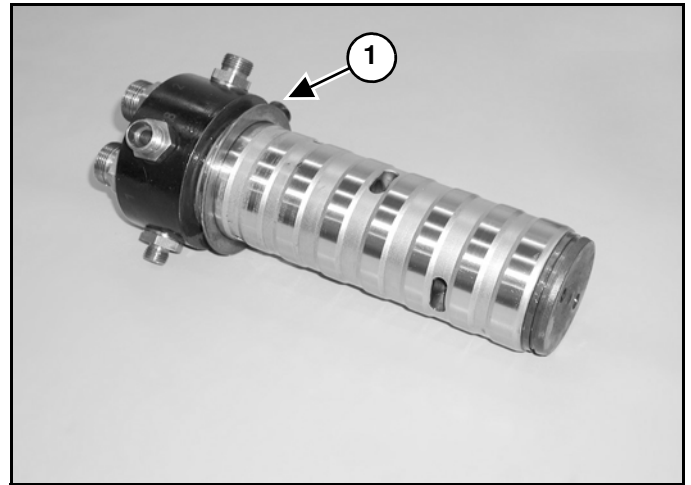

Remove the washer (Item 1) [Figure 20-80-15] from the rotor.

NOTE: Use care not to scratch the rotor surface as damage to the finished surface could cause internal leakage.

Figure 20-80-16

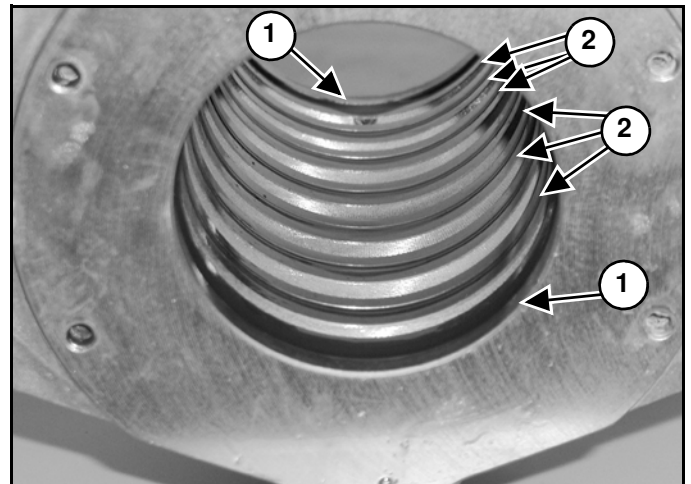

Remove the 2 seals (Item 1) and 6 O-rings (Item 2) [Figure 20-80-16].

SWING MOTOR (CONTÍD)

Disassembly (Contíd)

Figure 20-90-29

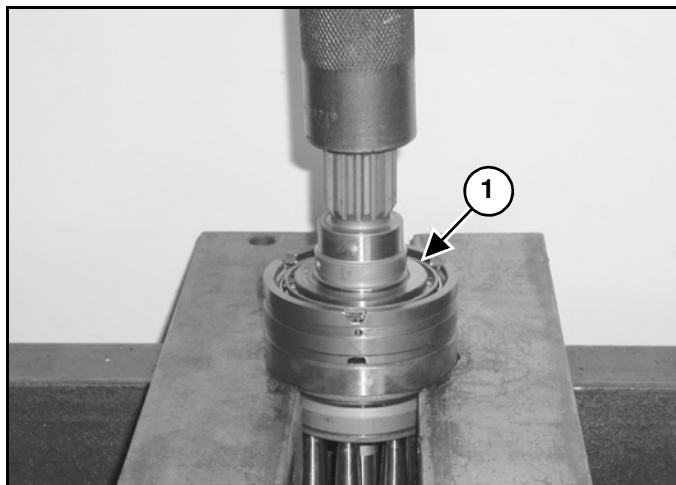

Remove the outer bearing (Item 1) [Figure 20-90-29].

Figure 20-90-30

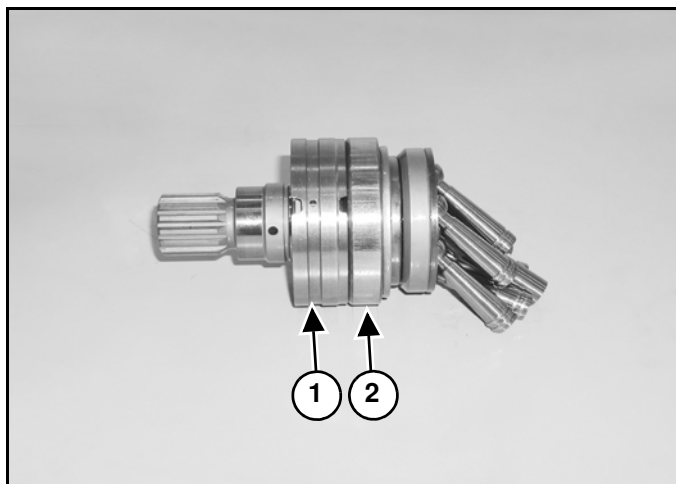

Remove the carrier (Item 1) and bearing race (Item 2) [Figure 20-90-30]

Figure 20-90-31

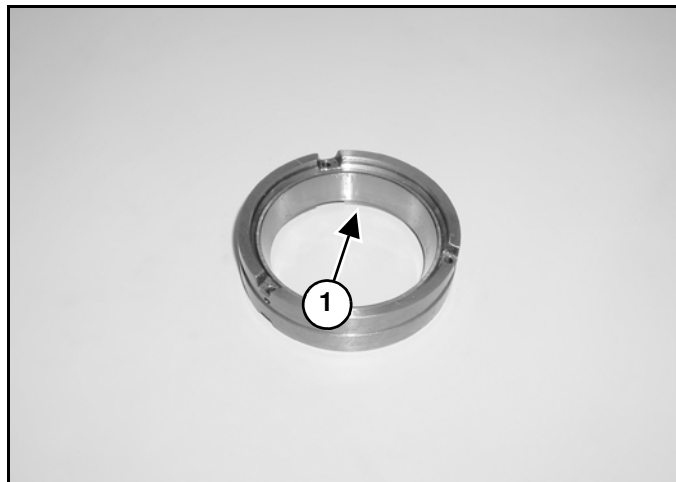

Remove the bearing race (Item 1) [Figure 20-90-31] from the carrier.

Put the shaft and bearing assembly in a press.

Figure 20-90-32

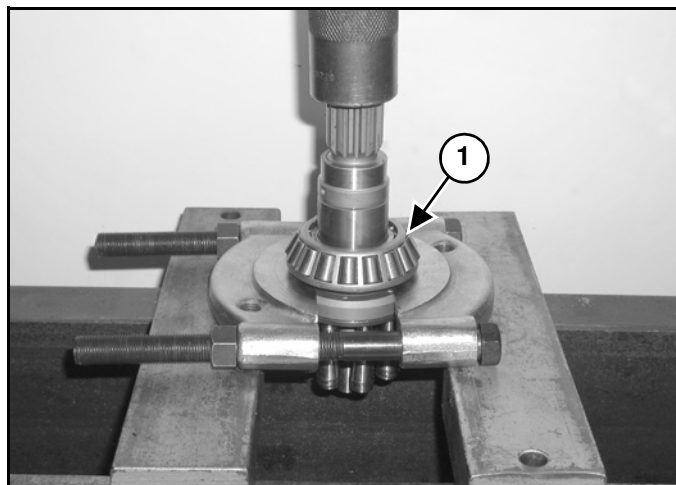

Remove the inner bearing (Item 1) [Figure 20-90-32].

SWING MOTOR DRIVE CARRIER (CONT'D)

Parts Identification

- 1 Snap Ring
- 2 Plunger Disc
- 3 O-Ring
- 4 Bolt
- 5 Brake Housing
- 6 Seal
- 7 Seal
- 8 Brake Disc
- 9 Piston
- 10 Belleville Spring
- 11 Spring Support
- 12 Driveshaft
- 13 Shim
- 14 Thrust Washer
- 15 Shim
- 16 Bearing
- 17 Gear
- 18 Pin
- 19 Bearing
- 20 Sun Gear
- 21 Pinion Cage
- 22 Planetary Gear
- 23 Nut
- 24 Locking Plate
- 25 Bearing
- 26 Seal
- 27 Drive Housing
- 28 Bearing
- 29 Seal
- 30 Washer
- 31 Pinion

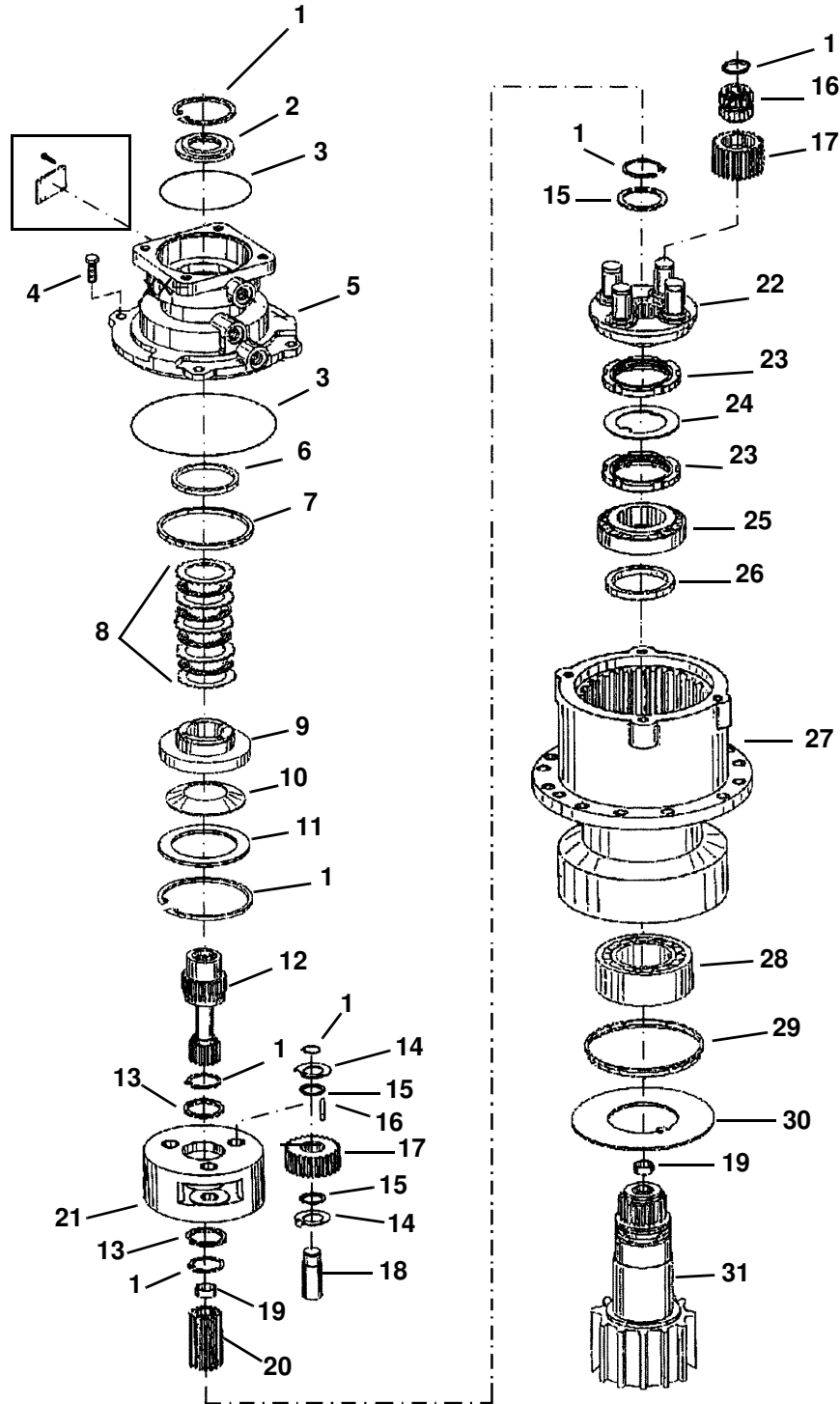

SWING MOTOR DRIVE CARRIER (CONT'D)

Assembly

Clean all components in solvent and dry with compressed air.

Replace all seals and components that are worn or damaged.

Figure 20-91-41

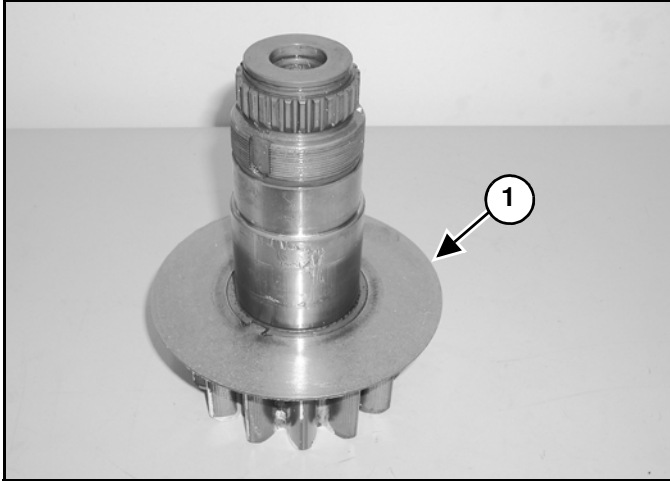

Install the washer (Item 1) [Figure 20-91-41].

Figure 20-91-42

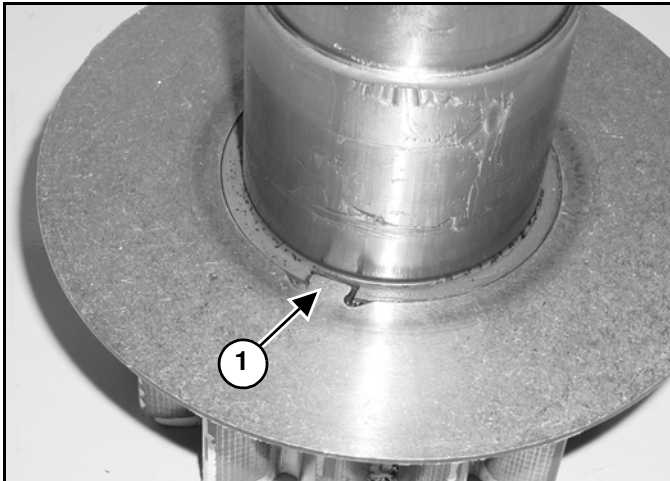

NOTE: Make sure the tab (Item 1) [Figure 20-91-42] is installed in the slot of the shaft.

Figure 20-91-43

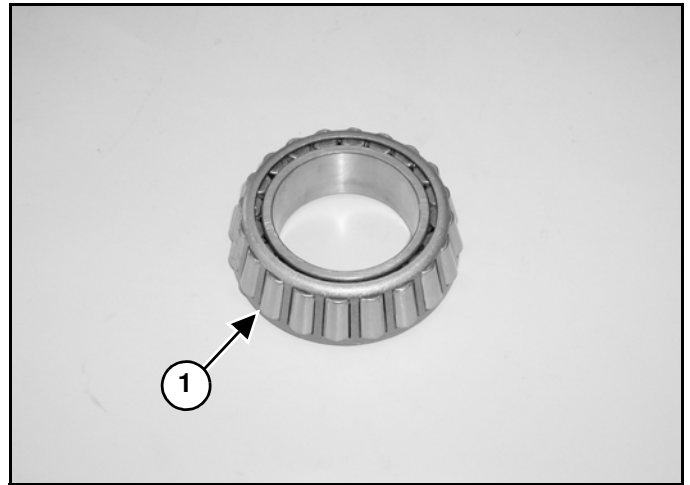

Pack the lower bearing (Item 1) [Figure 20-91-43] with a good quality high temperature NLGI grease.

Figure 20-91-44

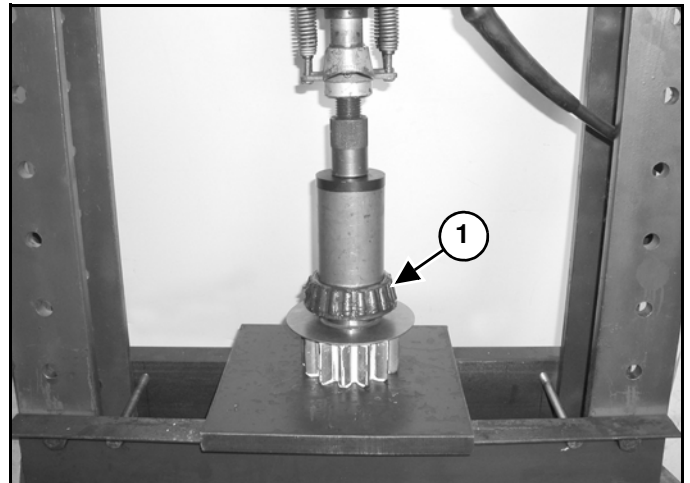

Press the bearing (Item 1) [Figure 20-91-44] on the shaft.

SWING MOTOR DRIVE CARRIER (CONT'D)

Assembly (Cont'd)

Figure 20-91-81

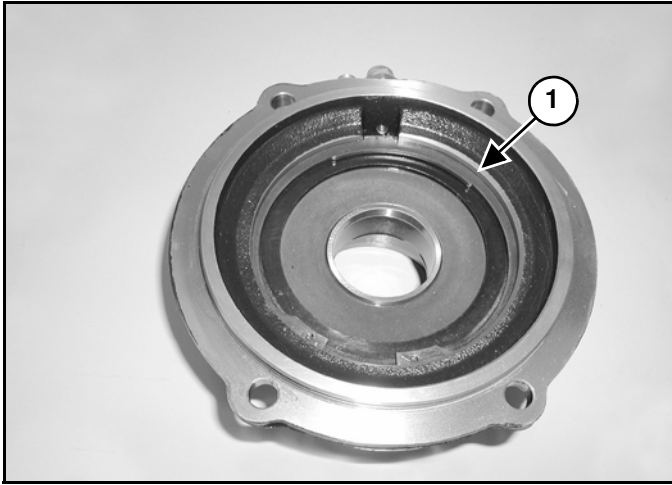

Install the snap ring (Item 1) [Figure 20-91-81].

Figure 20-91-82

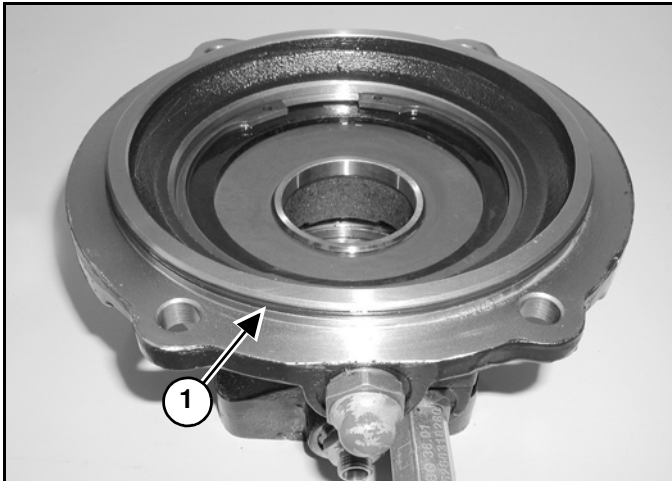

Install the O-ring (Item 1) [Figure 20-91-82].

Figure 20-91-83

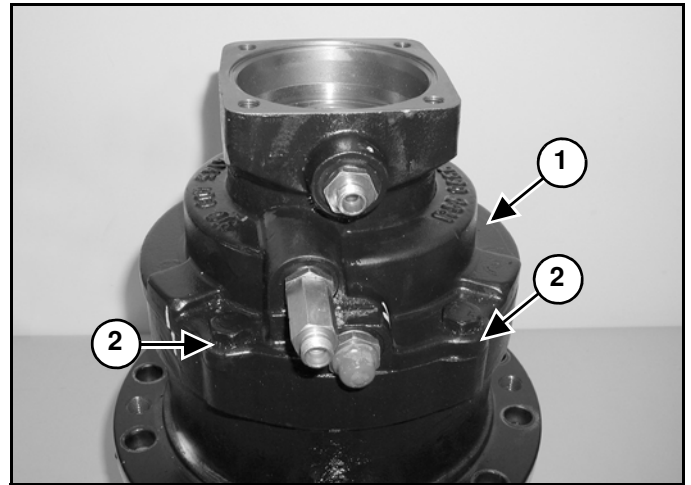

Install the brake housing (Item 1) [Figure 20-91-83] on the carrier.

Install the four bolts (Item 2) [Figure 20-91-83]. Tighten the bolts to 63 ft.-lb. (86 N·m) torque.

Figure 20-91-84

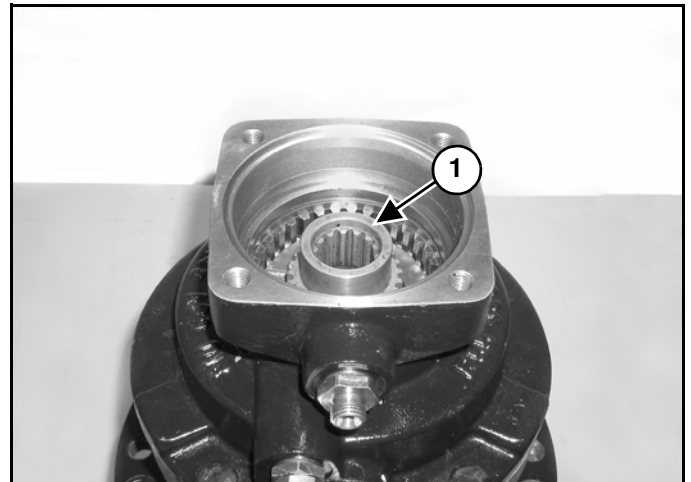

Install the driveshaft (Item 1) [Figure 20-91-84].

SWING BRAKE RELEASE VALVE (CONT'D)

Disassembly And Assembly

Place the valve in a vise that is equipped with soft jaws.

Figure 20-93-3

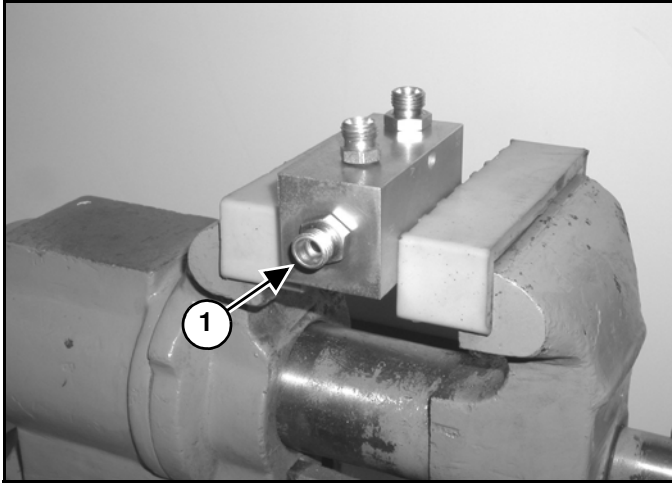

Remove the fitting (Item 1) [Figure 20-93-3] from the iRi port.

Figure 20-93-4

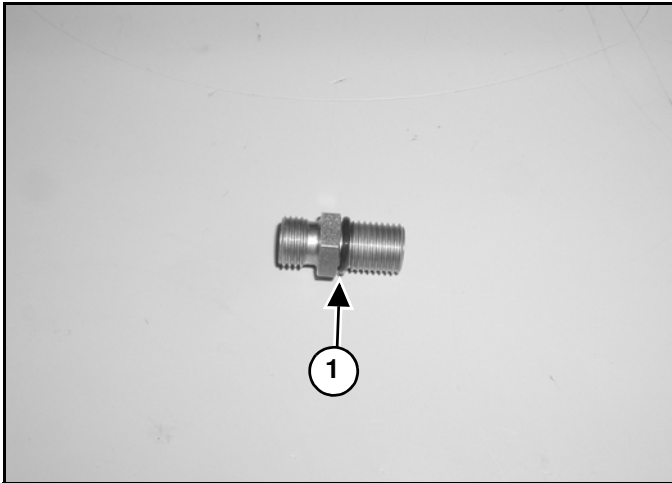

Remove the O-ring (Item 1) [Figure 20-93-4] from the fitting.

Figure 20-93-5

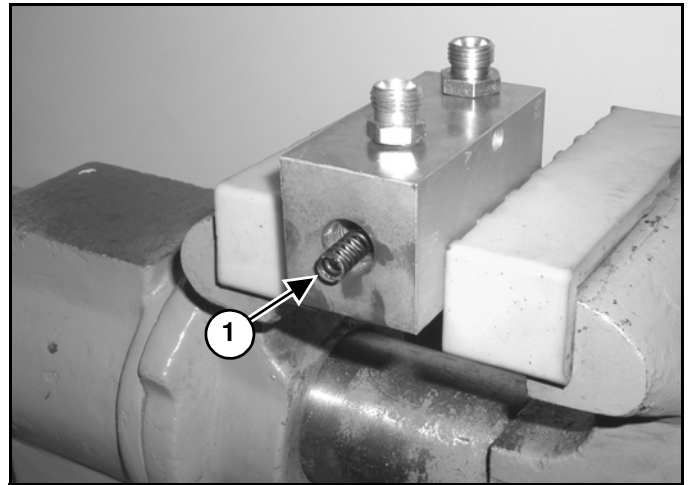

Remove the spring (Item 1) [Figure 20-93-5].

Figure 20-93-6

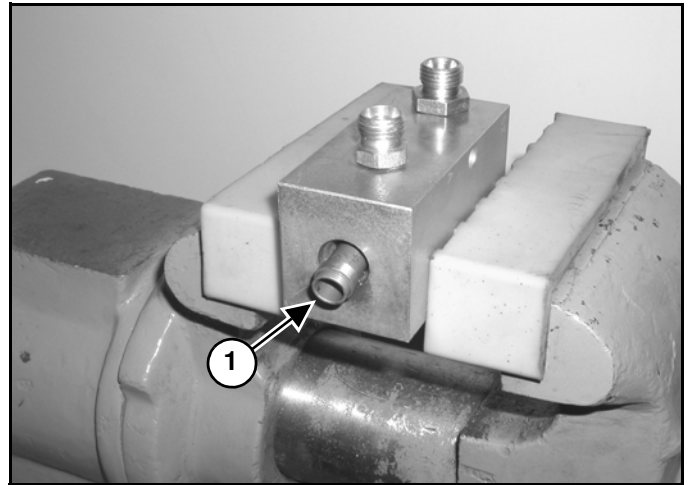

Remove the spool (Item 1) [Figure 20-93-6].

JOYSTICK LOCKOUT/TWO SPEED VALVE (CONT'D)

Disassembly And Assembly (Cont'd)

Figure 20-102-11

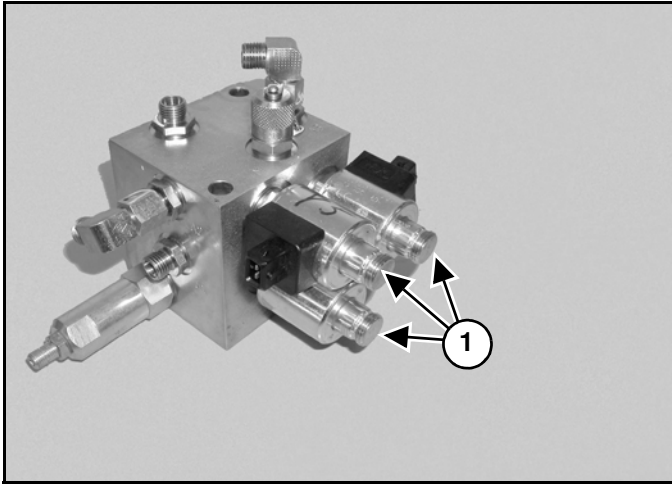

Mark and remove the coils (Item 1) [Figure 20-102-11].

Figure 20-102-12

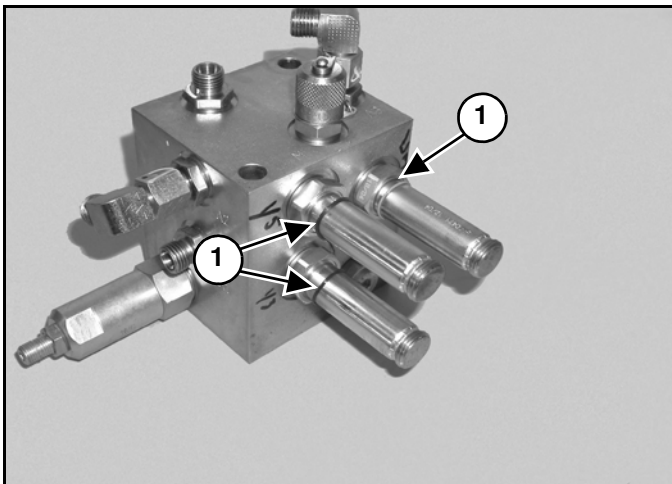

Remove the O-rings (Item 1) [Figure 20-102-12] from the spools.

Figure 20-102-13

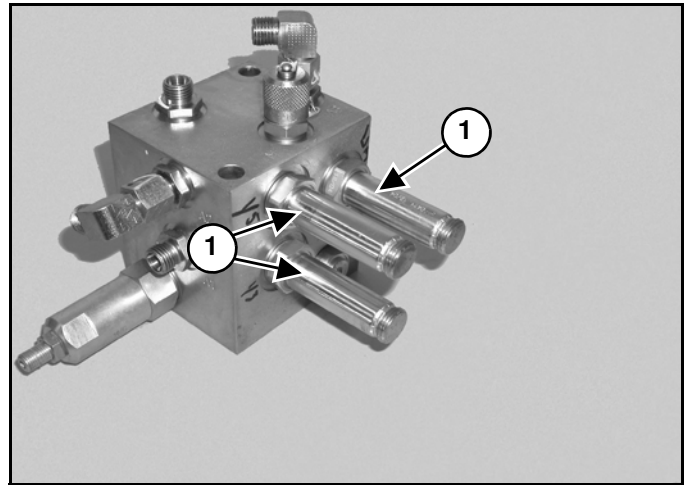

Remove the spools (Item 1) [Figure 20-102-13].

Figure 20-102-14

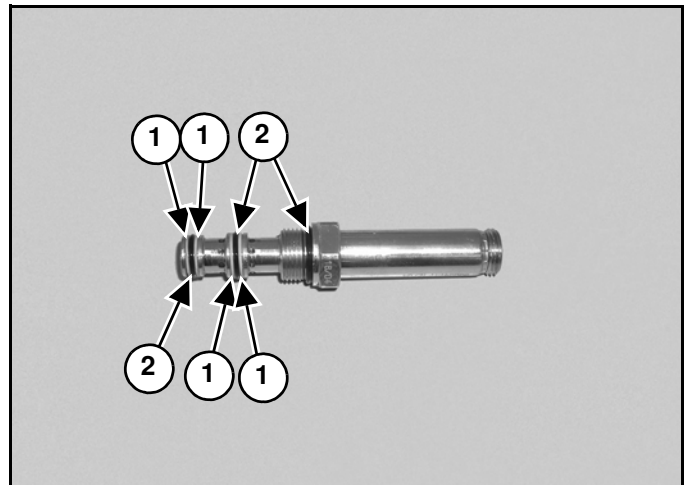

Remove the back-up rings (Item 1) and O-rings (Item 2) [Figure 20-102-14].

RIGHT CONTROL LEVER (JOYSTICK) (CONT'D)

Disassembly And Assembly (Cont'd)

Figure 20-110-18

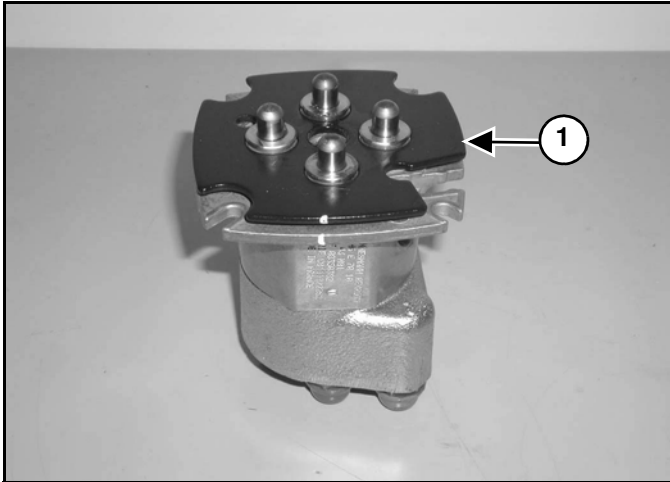

Remove the plate (Item 1) [Figure 20-110-18].

Figure 20-110-19

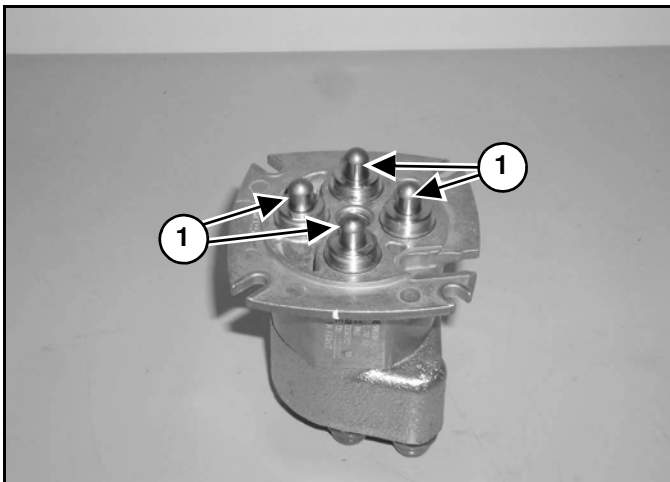

Mark and remove the plunger assemblies (Item 1) [Figure 20-110-19].

NOTE: Install the plunger assemblies in the same bore the plungers were removed from.

Figure 20-110-20

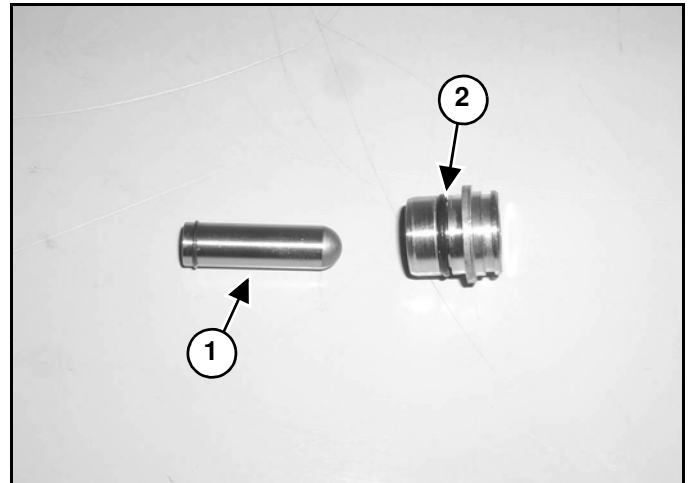

Remove the push rod (Item 1) [Figure 20-110-20] from the plunger body.

Remove the O-ring (Item 2) [Figure 20-110-20].

Figure 20-110-21

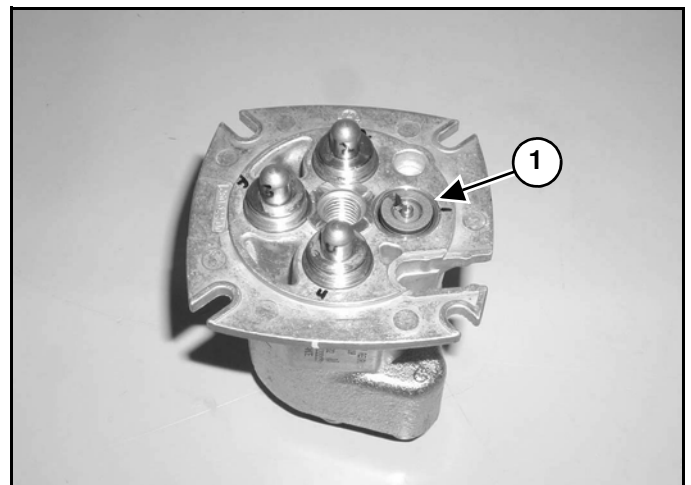

Remove the spool assemblies (Item 1) [Figure 20-110-21].

NOTE: Install the spool assemblies in the same bore the spools were removed from.

LEFT CONTROL LEVER (JOYSTICK) (CONTÍD)

Disassembly And Assembly (Contíd)

Figure 20-111-18

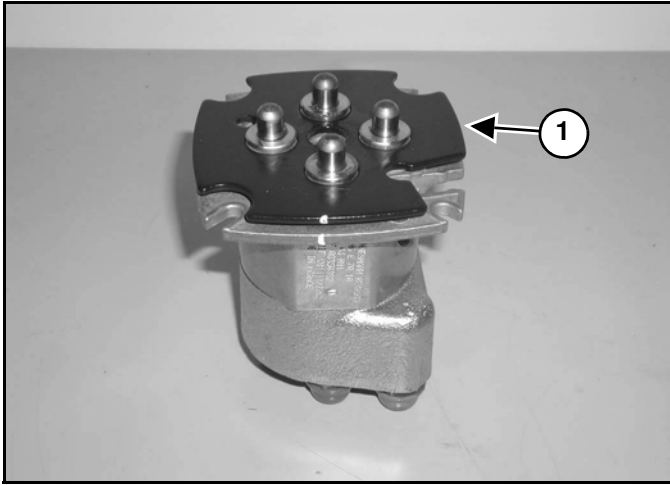

Remove the plate (Item 1) [Figure 20-111-18].

Figure 20-111-19

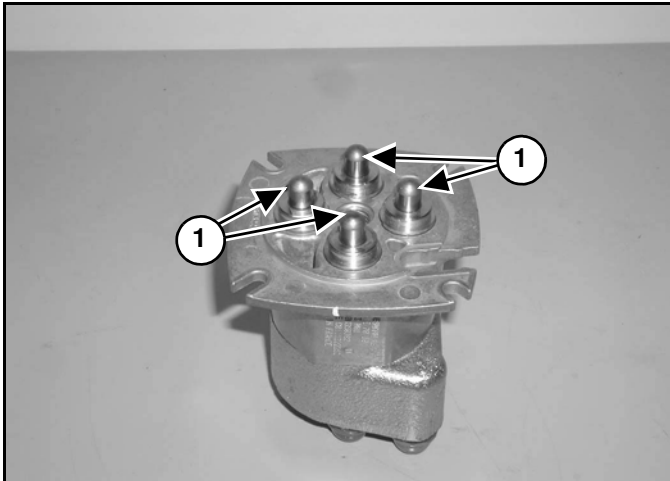

Mark and remove the plunger assemblies (Item 1) [Figure 20-111-19].

NOTE: Install the plunger assemblies in the same bore the plungers were removed from.

Figure 20-111-20

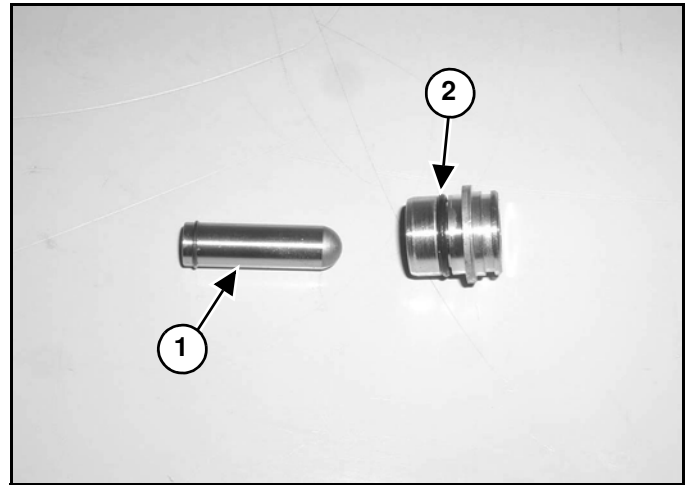

Remove the push rod (Item 1) [Figure 20-111-20] from the plunger body.

Remove the O-ring (Item 2) [Figure 20-111-20].

Figure 20-111-21

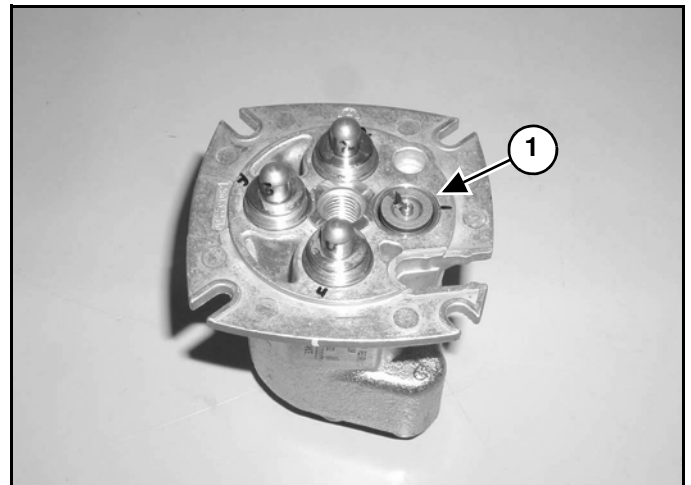

Remove the spool assemblies (Item 1) [Figure 20-111-21].

NOTE: Install the spool assemblies in the same bore the spools were removed from.

CLICK HERE TO **DOWNLOAD** THE COMPLETE MANUAL

- Thank you very much for reading the preview of the manual.
- You can download the complete manual from: www.heydownloads.com by clicking the link below



- Please note: If there is no response to **CLICKING** the link, please download this PDF first and then click on it.

CLICK HERE TO **DOWNLOAD** THE COMPLETE MANUAL

TRAVEL LEVER/FOOT PEDAL VALVE (CONTÍD)

Disassembly And Assembly (Contíd)

Figure 20-112-19

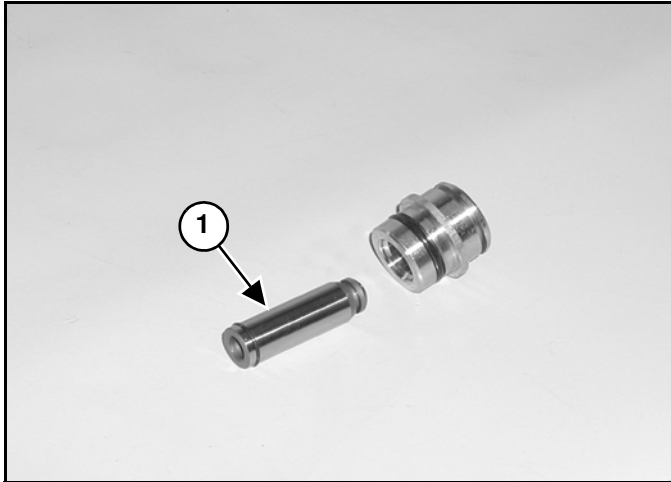

Remove the push rod (Item 1) [Figure 20-112-19] from the plunger body.

Figure 20-112-20

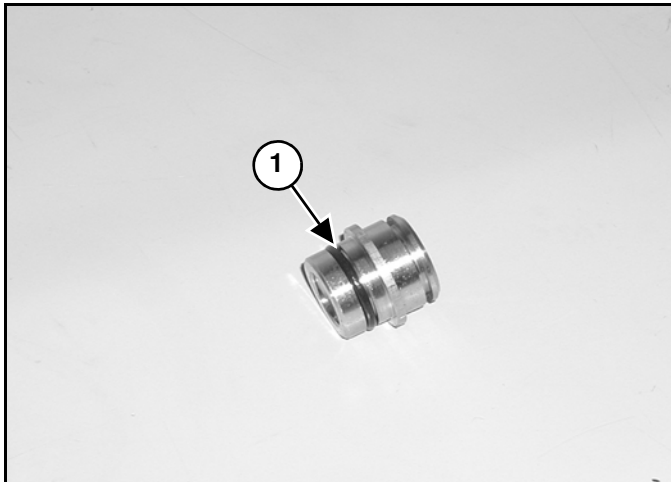

Remove the O-ring (Item 1) [Figure 20-112-20] from the plunger body.

Figure 20-112-21

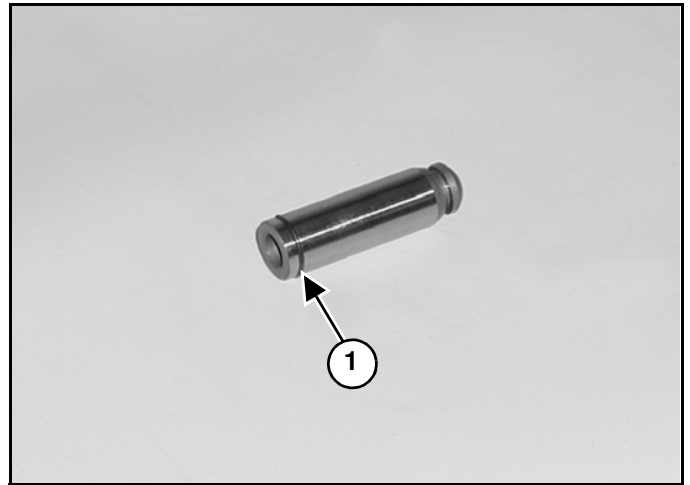

Remove the seal (Item 1) [Figure 20-112-21] from the push rod.

Figure 20-112-22

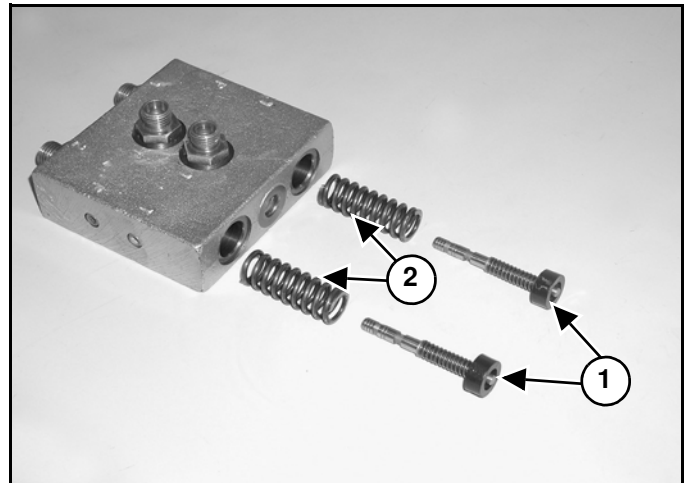

Remove the spool assemblies (Item 1) and springs (Item 2) [Figure 20-112-22].



HYDRAULIC BREAKER APPLICATION VALVE (CONT'D)

Disassembly And Assembly

Figure 20-160-4

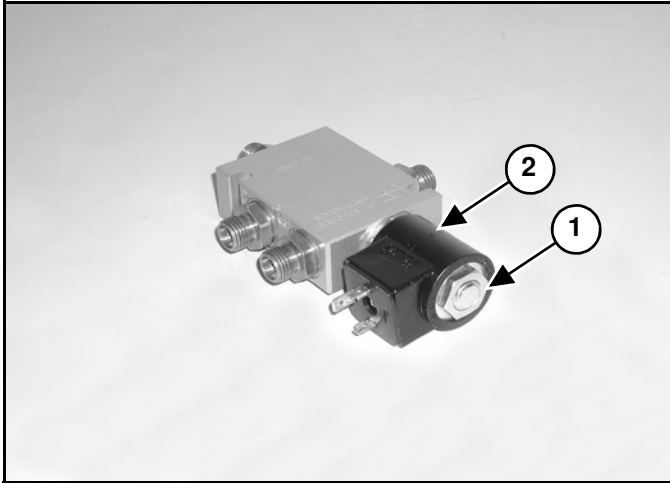

Remove the nut (Item 1) and coil (Item 2) [Figure 20-160-4] from the spool.

Installation: Tighten the nut to 3-5 ft.-lb. (4-7 N·m) torque.

NOTE: Overtightening the coil nut may cause spool or coil failure.

Figure 20-160-5

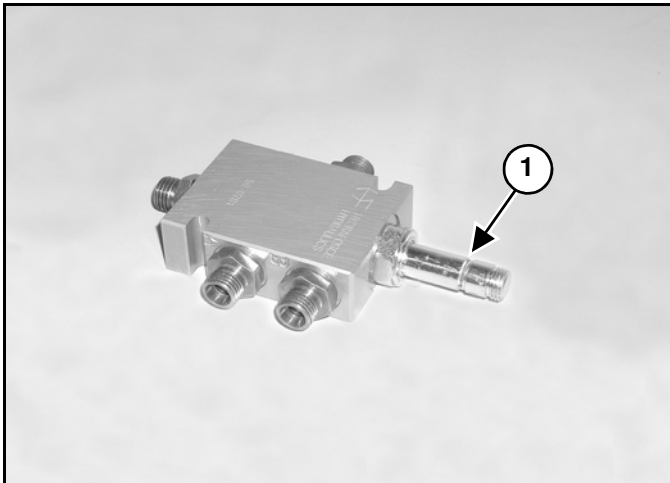

Remove the spool (Item 1) [Figure 20-160-5].

Figure 20-160-6

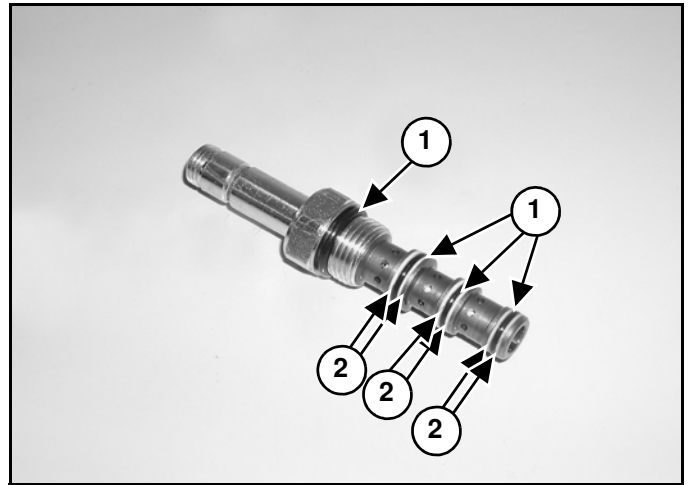

Remove the O-rings (Item 1) and back-up rings (Item 2) [Figure 20-160-6] from the spool.

Figure 20-160-7

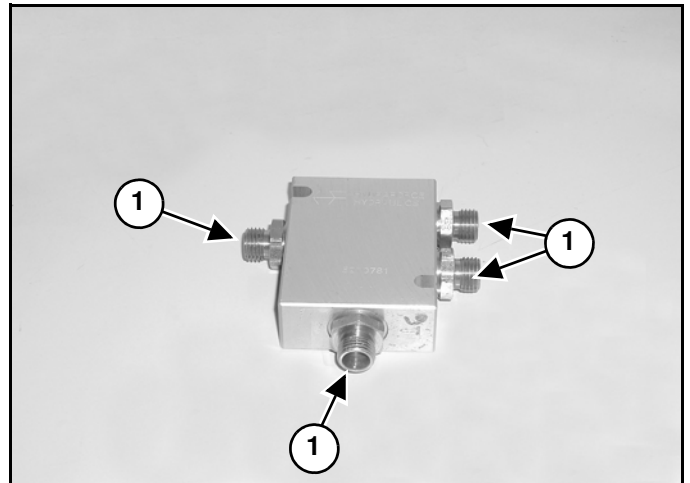

NOTE: Do not remove the 4 fittings (Item 1) [Figure 20-160-7] The fittings are welded to the valve block. Removing the fittings will damage the block and fittings.

Installation: Clean all components with solvent and dry with compressed air.

Check all components for burrs, scratches or other damage and replace if necessary.

Use new O-rings and back-up rings.

Apply clean hydraulic oil to the O-rings and back-up rings during assembly.

**AUXILIARY HYDRAULIC FLOW CONTROL/
HYDRAULIC BREAKER APPLICATION VALVE
(CONT'D)**

Disassembly And Assembly (Cont'd)

Figure 20-171-12

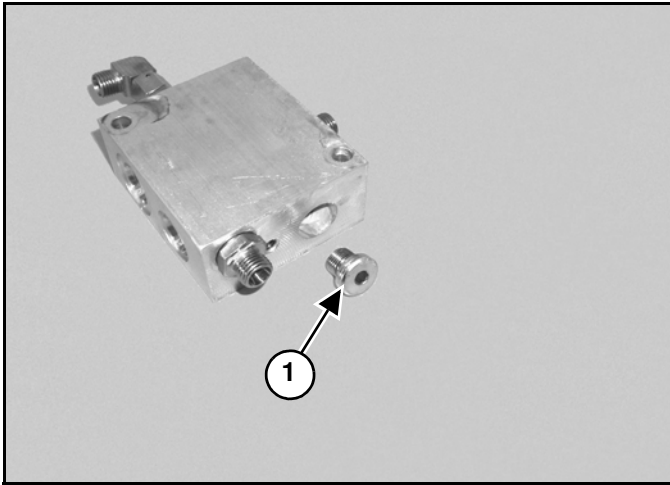

Remove the plug (Item 1) [Figure 20-171-12].

Figure 20-171-13

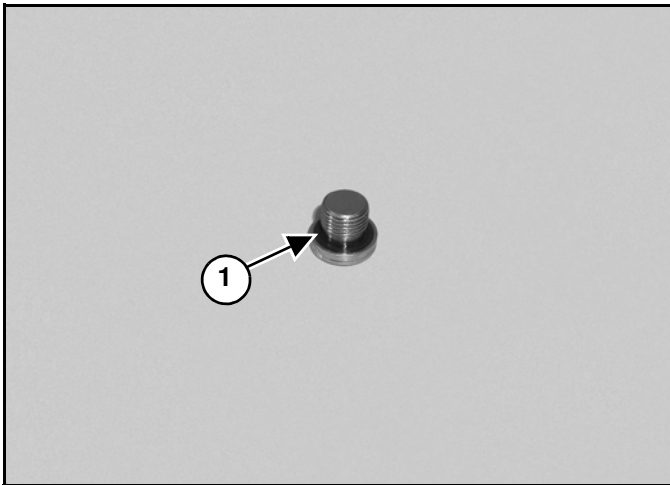

Remove the O-ring (Item 1) [Figure 20-171-13].

Figure 20-171-14

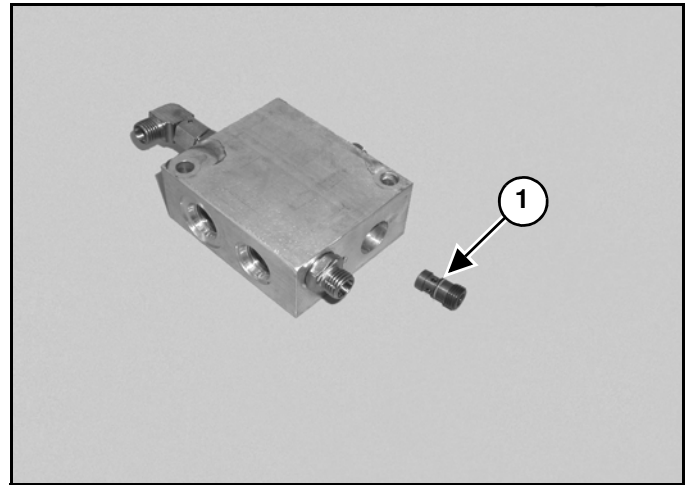

Remove the spool (Item 1) [Figure 20-171-14].

Figure 20-171-15

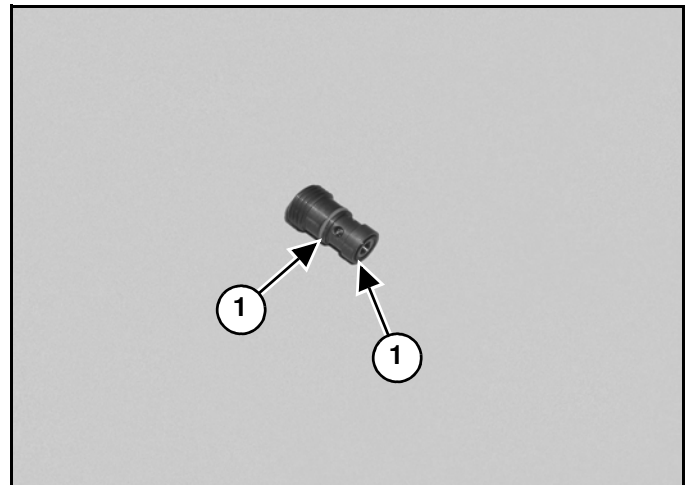

Remove the O-rings (Item 1) [Figure 20-171-15].

Installation: Clean all components with solvent and dry with compressed air.

Inspect all parts and replace any that are damaged.

Use new O-rings and back-up rings.

Apply clean hydraulic oil to the O-rings and back-up rings during assembly.

BLADE FLOAT VALVE (CONT'D)

Disassembly And Assembly

Figure 20-181-5

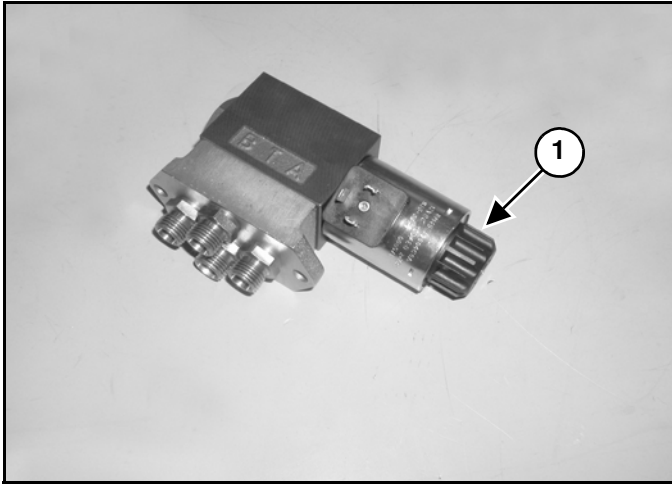

Remove the nut (Item 1) [Figure 20-181-5] from the solenoid valve.

Installation: Tighten the nut to 3-5 ft.-lb. (4-7 N·m) torque.

NOTE: Overtightening the coil nuts (Item 1) [Figure 20-181-5] may cause spool or coil failure.

Figure 20-181-6

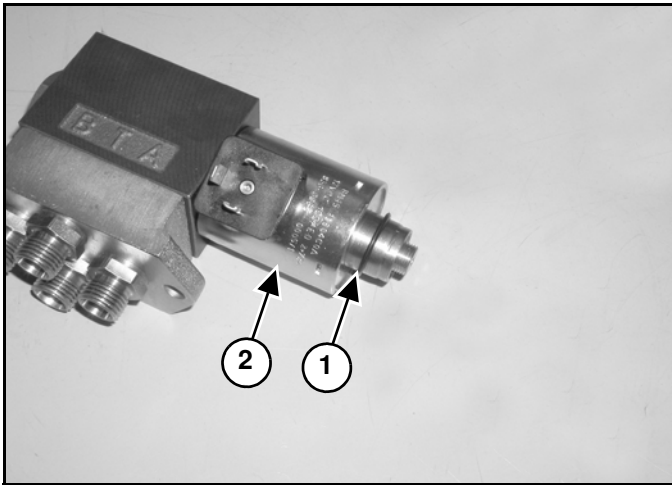

Remove the O-ring (Item 1) and coil (Item 2) [Figure 20-181-6].

Figure 20-181-7

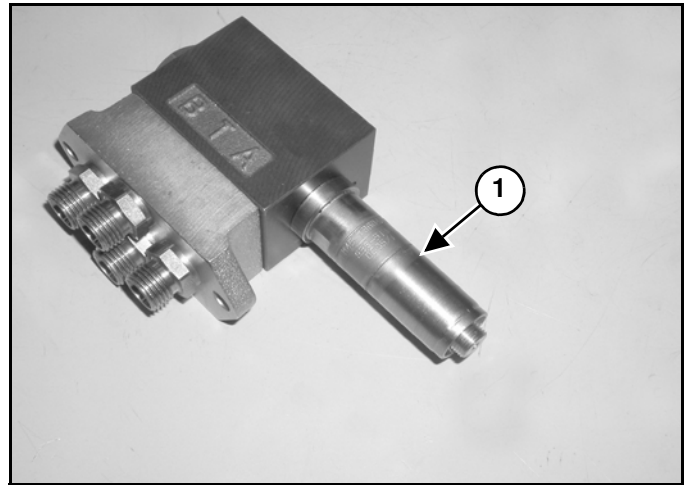

Remove the solenoid valve (Item 1) [Figure 20-181-7].

Figure 20-181-8

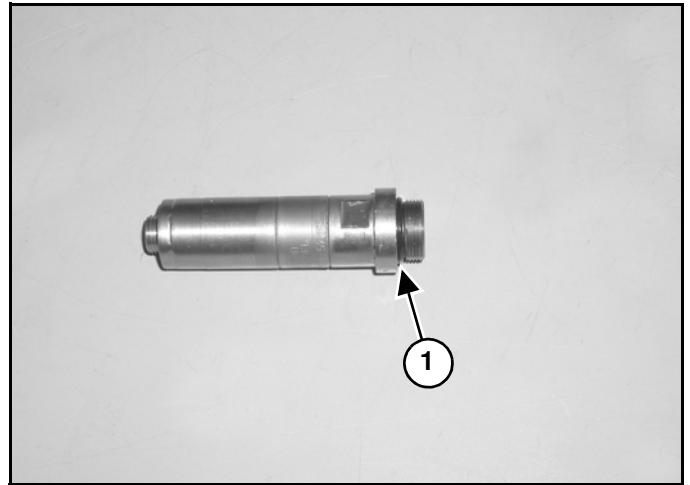

Remove the O-ring (Item 1) [Figure 20-181-8].

BOOM OFFSET VALVE (CONT'D)

Disassembly And Assembly (Cont'd)

Figure 20-190-35

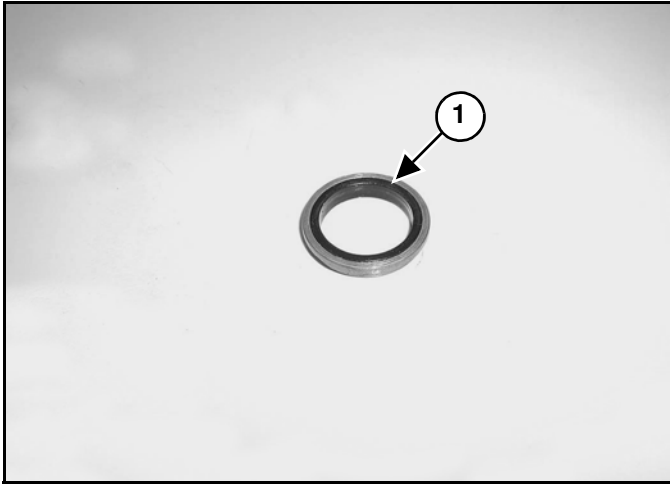

Remove the seal (Item 1) [Figure 20-190-35] from the seal carrier.

Figure 20-190-36

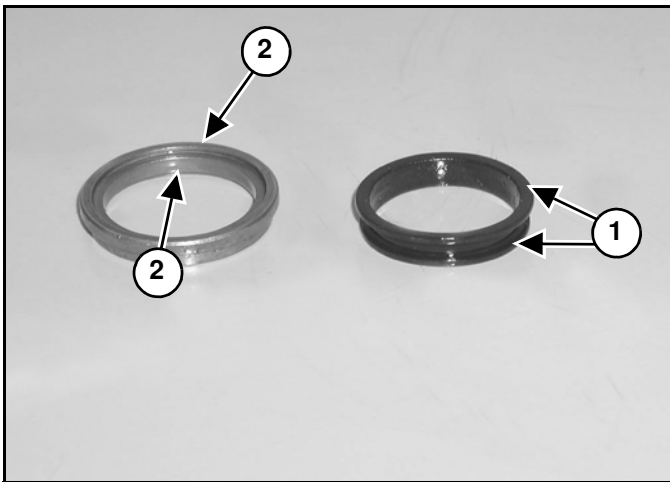

Installation: Make sure the lips (Item 1) on the seal fit into the grooves (Item 2) [Figure 20-190-36] on the seal carrier.

Figure 20-190-37

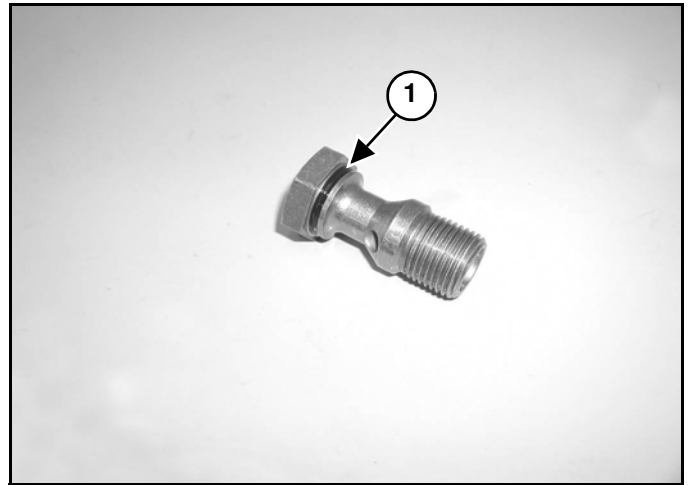

Remove the O-ring (Item 1) [Figure 20-190-37] from the bolt.

Installation: Clean all components with solvent and dry with compressed air.

Inspect all parts and replace any that are damaged.

Use new O-rings and back-up rings.

Apply clean hydraulic oil to the O-rings and back-up rings during assembly.

BOOM LOAD HOLDING VALVE (CONT'D)

Disassembly (Cont'd)

Figure 20-200-65

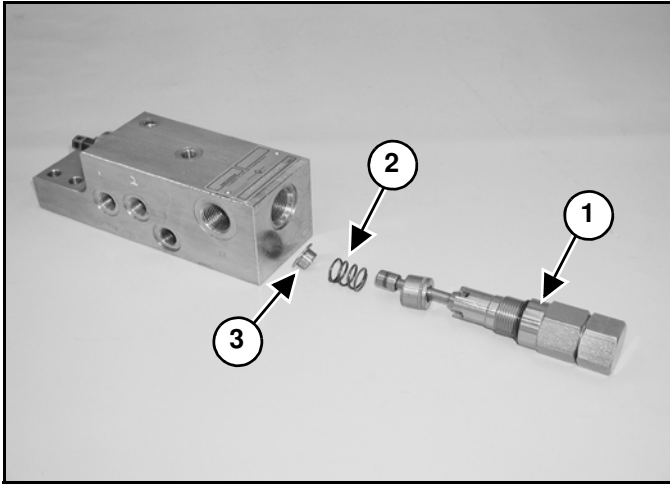

Remove the relief valve (Item 1), spring (Item 2) and spring seat (Item 3) [Figure 20-200-65].

Figure 20-200-66

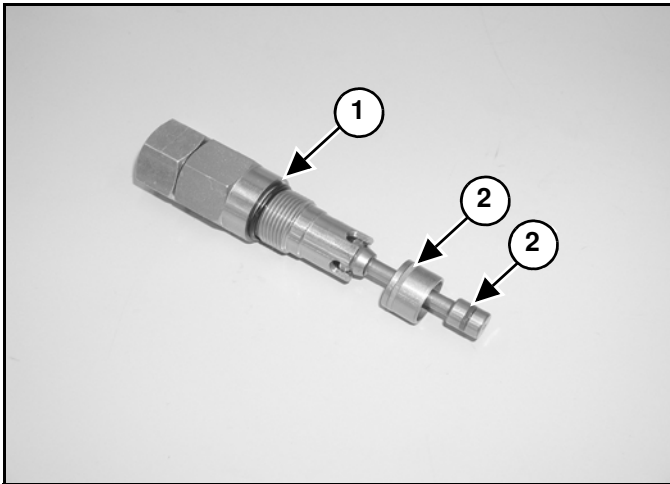

Remove the O-ring (Item 1) and seals (Item 2) [Figure 20-200-66] from the relief valve.

AUXILIARY HYDRAULICS SELECTOR VALVE

Removal And Installation

The procedure is the same for both right and left auxiliary hydraulic selector valves. The left side is shown.

Place the bucket on the ground.

WARNING

Hydraulic fluid escaping under pressure can have sufficient force to enter a person's body by penetrating the skin. This can cause serious injury and possible death if proper medical treatment by a physician familiar with this injury is not received immediately.

Stop the engine.

With the engine off, and the key in the run position, move the control levers to relieve hydraulic pressure.

IMPORTANT

When making repairs on hydraulic system, clean the work area before disassemble and keep all parts clean. Always use caps and plugs on hoses, tubelines and ports to keep dirt out. Dirt can quickly damage the system.

Mark the hoses and tubelines for correct installation.

Figure 20-220-2

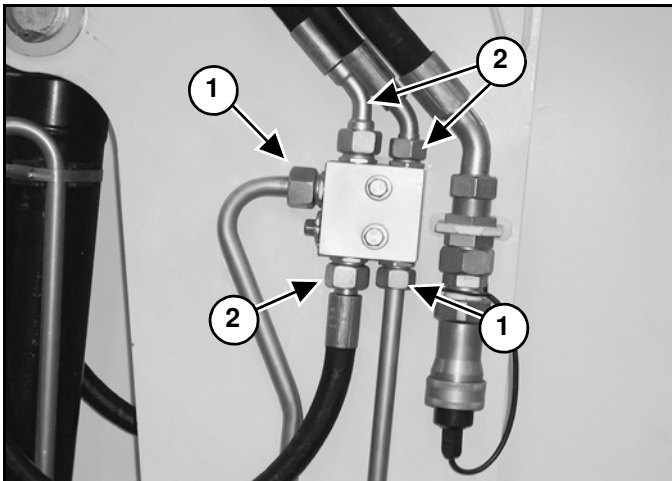

Remove the tubelines (Item 1) and hoses (Item 2) [Figure 20-220-2].

Figure 20-220-3

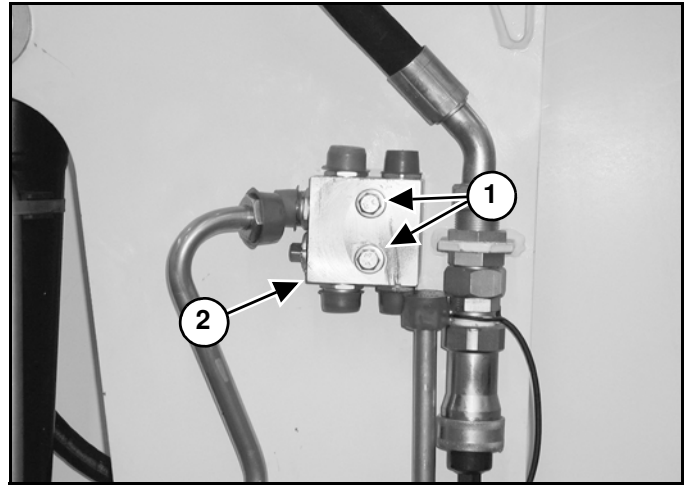

Remove the 2 bolts (Item 1) [Figure 20-220-3].

Installation: Tighten the bolts to 29-37 ft.-lb. (40-50 N·m) torque.

Remove the auxiliary hydraulics selector valve (Item 2) [Figure 20-220-3].

TRACKS (CONT'D)

Rubber Track Clearance (Cont'd)

Figure 30-20-4

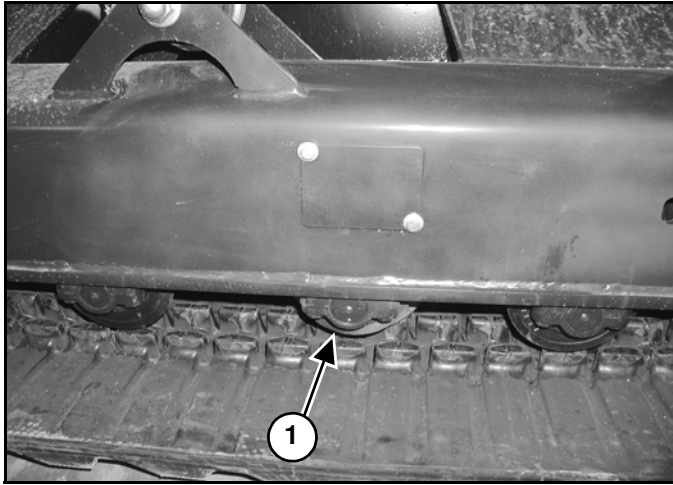
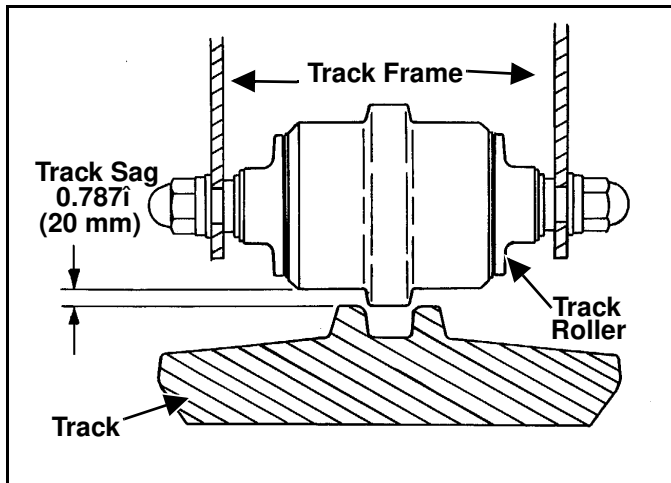

Figure 30-20-5



Measure the track sag at the third roller (Item 1) [Figure 30-20-4] from the front of the track frame. Do not get fingers in pinch points between the track and track roller. Use a bolt or dowel of the appropriate size to check the gap between the amount contact edge of the roller and the top edge of the track guide lug [Figure 30-20-5].

Rubber track clearance 0.787 inches (20 mm).



AVOID INJURY

Keep fingers and hands out of pinch points when checking the track tension.

Steel Track Clearance

NOTE: The wear of the pins and bushings on the undercarriage vary with the working conditions and the different types of soil conditions. It is necessary to inspect track tension and maintain the correct tension. (See SERVICE SCHEDULE on Page 10-50-1 for the correct service interval.)

NOTE: On new excavators or on excavators with new steel tracks installed, check and adjust as needed the steel track clearance two to three times on the first day of operation.

Park the excavator on a flat and level surface.

Figure 30-20-6

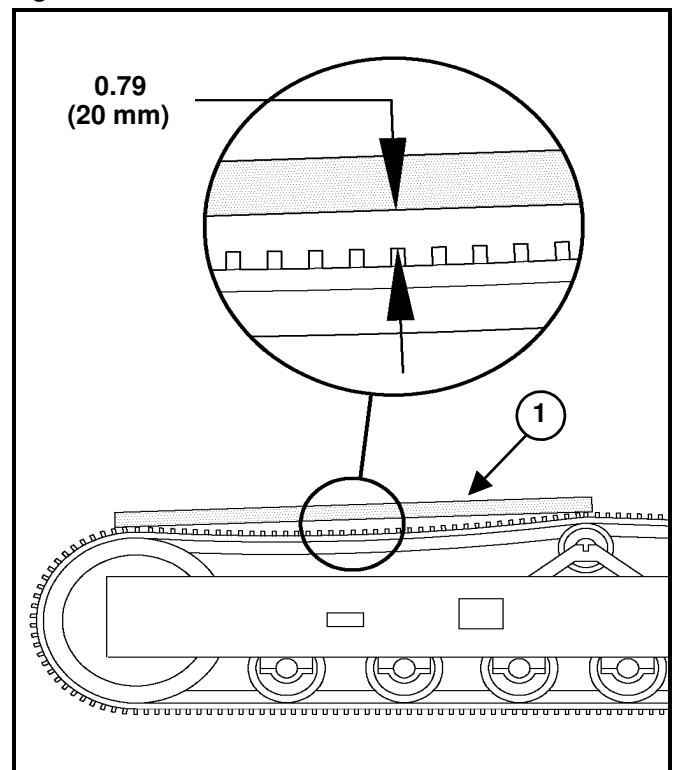

Put a straight edge (Item 1) on the top of the track surface between the rear sprocket and the top idler wheel. Measure between the top of the track and the bottom of the straight edge [Figure 30-20-6].

Steel track clearance 0.79 inches (20 mm).

TRACK FRAME (CONT'D)

Drive Sprocket Removal And Installation

Remove the track. (See Rubber Track Removal And Installation on Page 30-20-6.)

Figure 30-30-12



Remove the sixteen bolts (Item 1) [Figure 30-30-12].

Installation: Apply thread adhesive (Loctite® 242) to the bolt threads. Tighten the bolts to 177-203 ft.-lb. (240-275 N·m) torque.

Figure 30-30-13

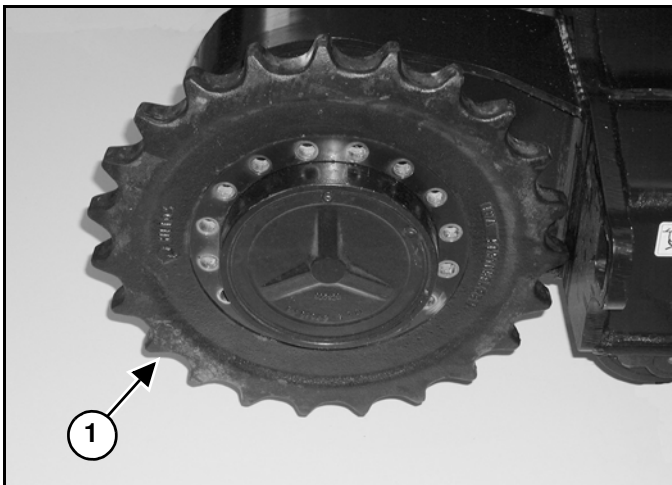

Remove the drive sprocket (Item 1) [Figure 30-30-13].

TRACK IDLER (CONT'D)

Assembly (Cont'd)

Figure 30-40-27

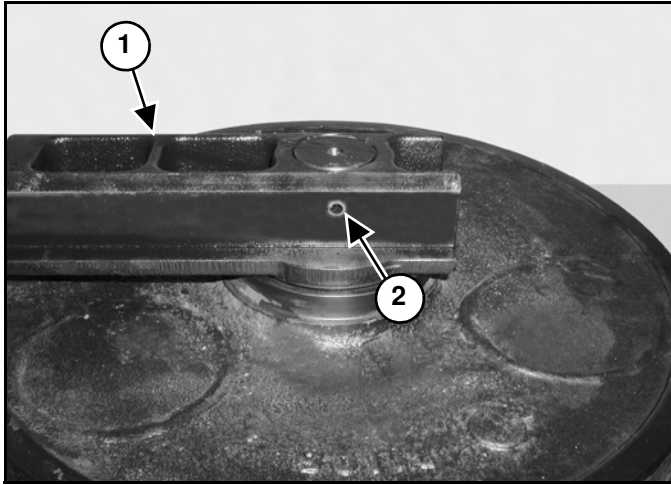

Press down on the mount (Item 1) and install the roll pin (Item 2) [Figure 30-40-27].

Figure 30-40-28

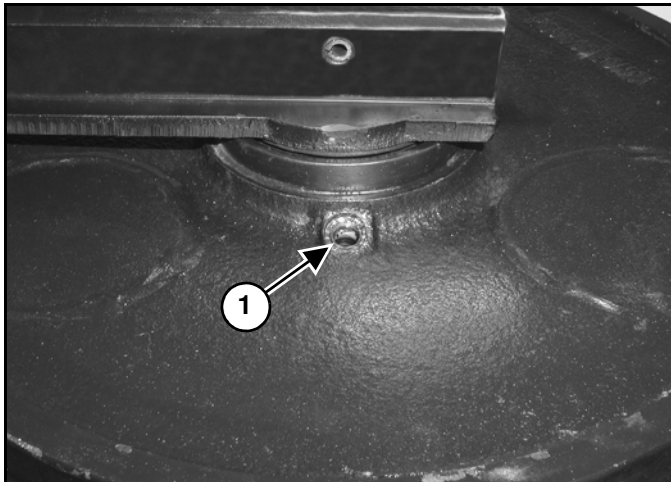

Add 12 oz. (0.35 L) of 80 w/90 gear oil through the fill hole (Item 1) [Figure 30-40-28].

Apply thread adhesive (Loctite® 242) to the threads of the plug.

Figure 30-40-29

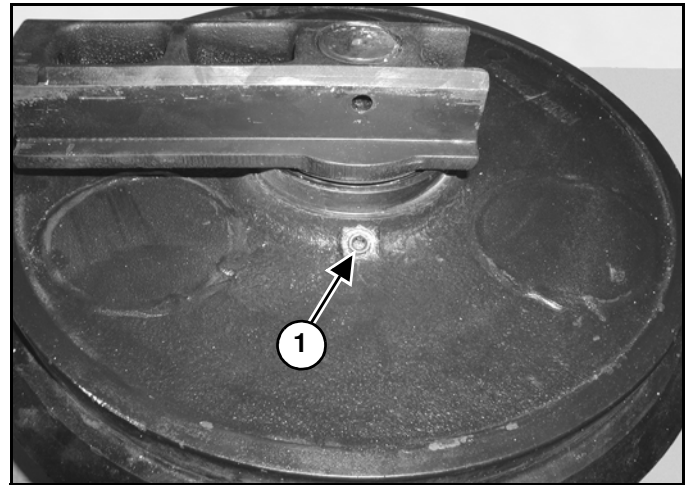

Install the plug (Item 1) [Figure 30-40-29].

Figure 30-40-30

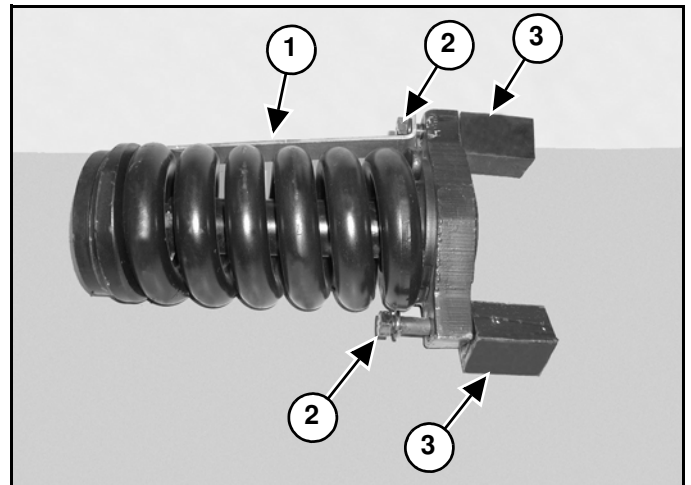

Install the track tension guide (Item 1) [Figure 30-40-30] on the bolt and washer.

Install the bolts and washers (Item 2) [Figure 30-40-30] through the recoil spring frame.

Install the spacer blocks (Item 3) [Figure 30-40-30] on the bolts.

Install the recoil spring assembly on the idler mounts.

GREASE CYLINDER

Parts Identification

1. ADJUSTER
2. WASHER
3. PLATE
4. HOUSING
5. SEAL
6. SEAL
7. BACK-UP RING
8. CYLINDER

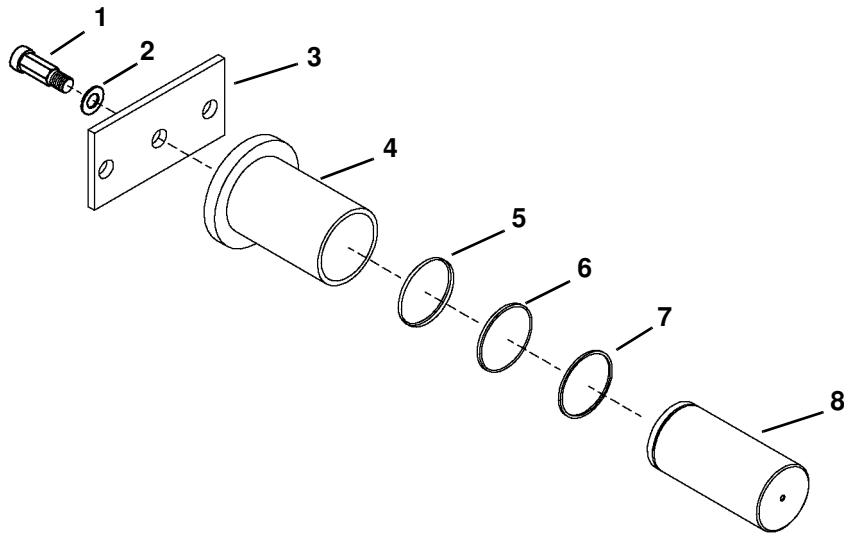

TRACK DAMAGE IDENTIFICATION (CONT'D)

Lug Abrasion

Prevention:

Figure 30-80-16

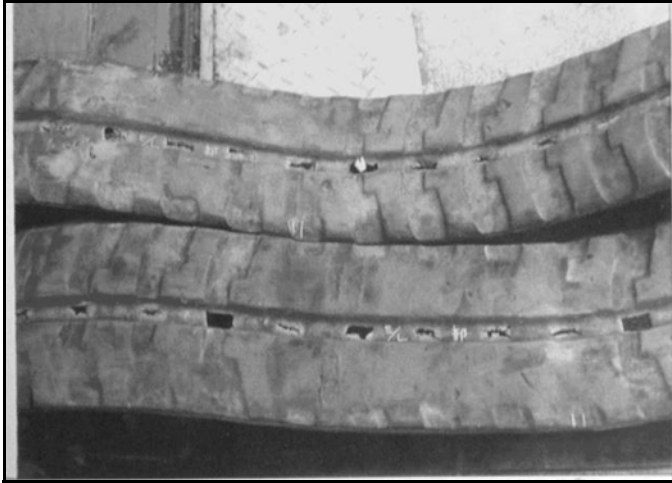
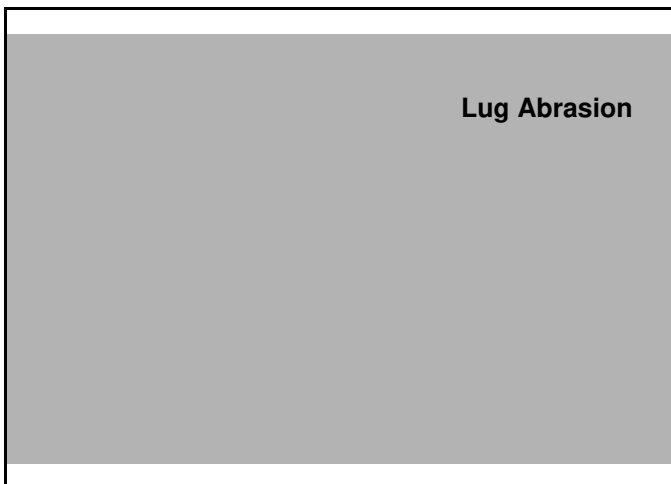

Figure 30-80-17



As its service time proceeds, the lug side inevitably undergoes abrasion [Figure 30-80-16] & [Figure 30-80-17].

Replacement:

No replacement is required.

Causes Of The Damage:

Lug abrasion is more or less inevitable. Even if lug abrasion is proceeding, the rubber track can be used. However, as the traction performance deteriorates accordingly, it is highly recommended to replace the abraded tracks with new ones when the lug height becomes less than 0.197 in (5 mm).

Prevention:

In order to prevent the rubber track from abnormal or premature abrasion, following operating conditions should be avoided:

Making quick and repeated turns on concrete and asphalt roads

Driving up and down hilly paths with slippage

Making frequent turns on paths covered with rocks and wood

UPPERSTRUCTURE (CONT'D)

Removal And Installation (Cont'd)

Figure 40-10-6

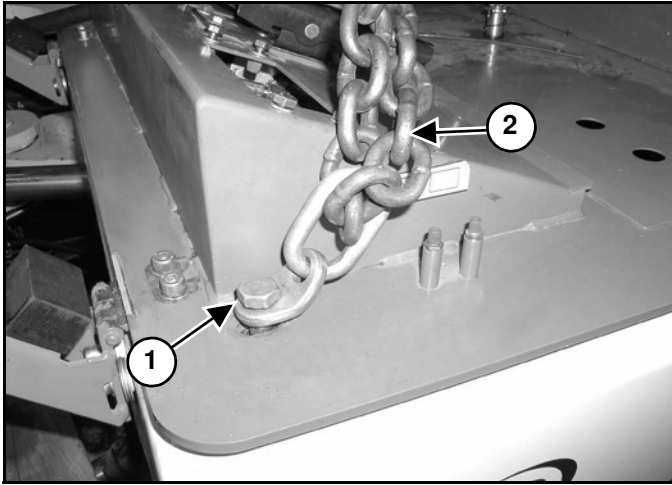

Install a lifting bracket (Item 1) on the left front cab mount. Install a chain (Item 2) [Figure 40-10-6] on the lifting bracket.

Figure 40-10-7

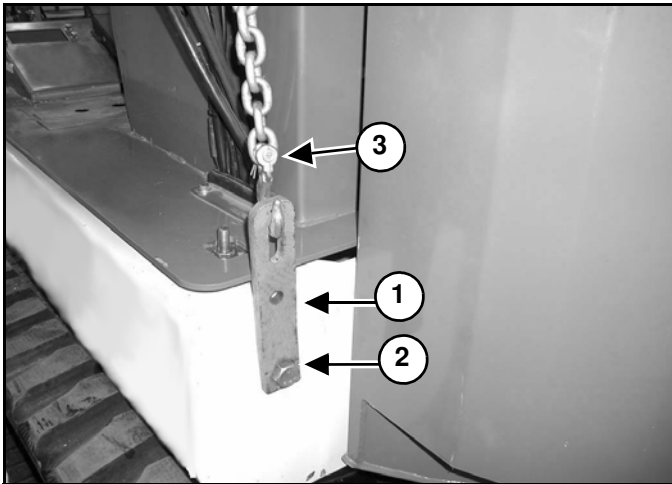

Install the rear lifting brackets (Item 1) using the counterweight bolt holes. Use two 20 mm x 64 mm MC grade 8.8 bolts (Item 2) [Figure 40-10-7] to install the brackets.

Install the chains (Item 3) [Figure 40-10-7] to the lifting brackets.

Figure 40-10-8

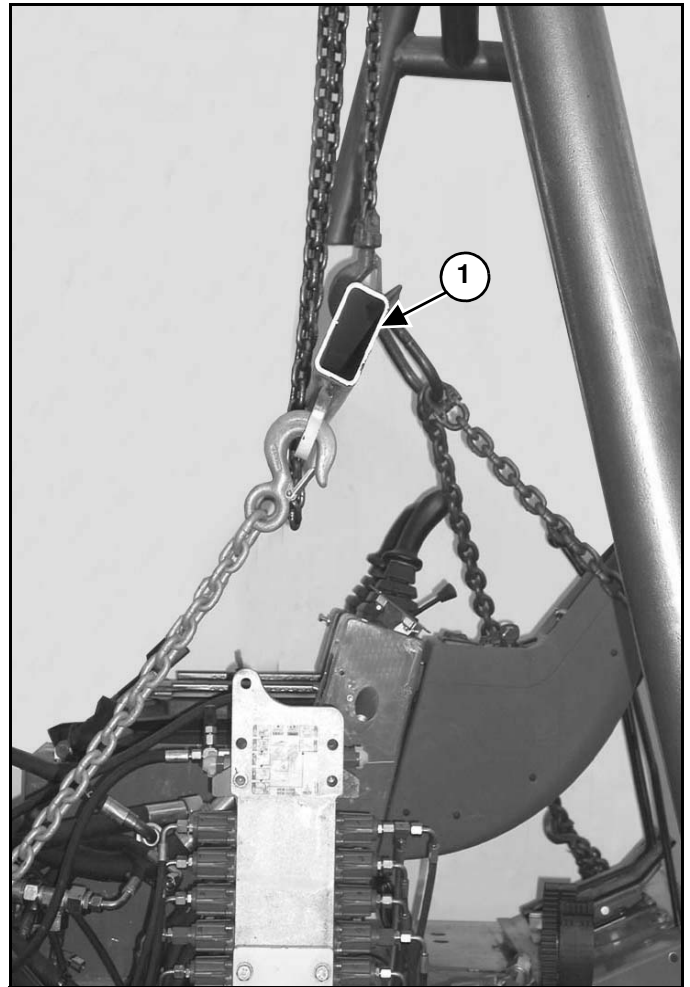

Position the spreader bar (Item 1) [Figure 40-10-8] as shown and attach the lifting chains to the bar.

NOTE: The chain hoist the spreader bar and lifting chains are attached to must have a swivel hook to allow the upperstructure to be turned.

Apply a small amount of lifting pressure to the upperstructure with the chain hoist.

CAB (CONTÍD)

Removal And Installation (Contid)

Figure 40-20-15

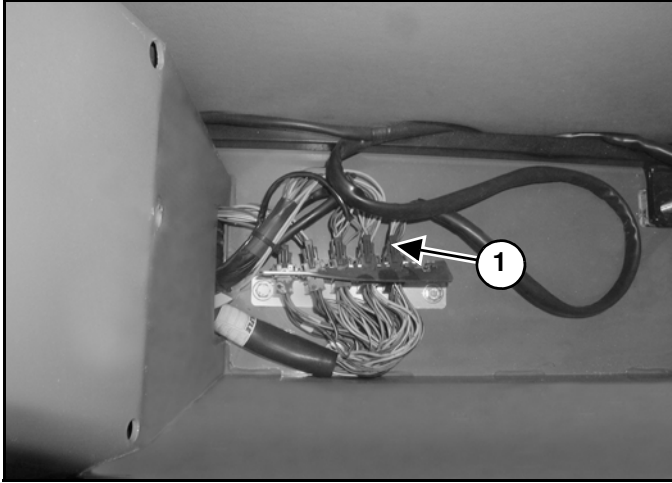

Disconnect the wire harness (Item 1) [Figure 40-20-15].

Figure 40-20-16

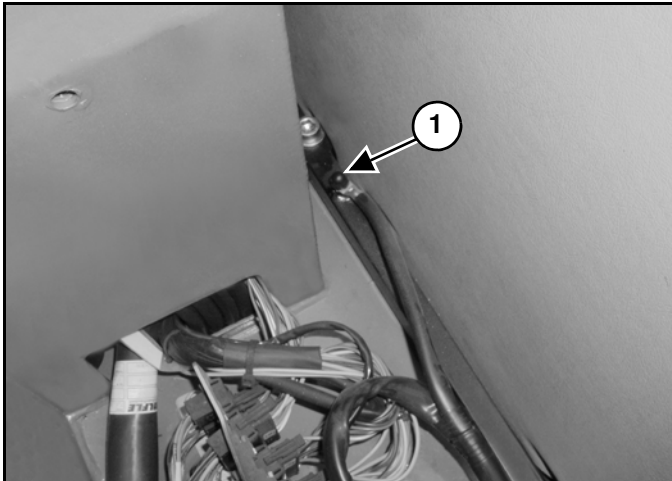

Remove the ground cable (Item 1) [Figure 40-20-16].

Figure 40-20-17

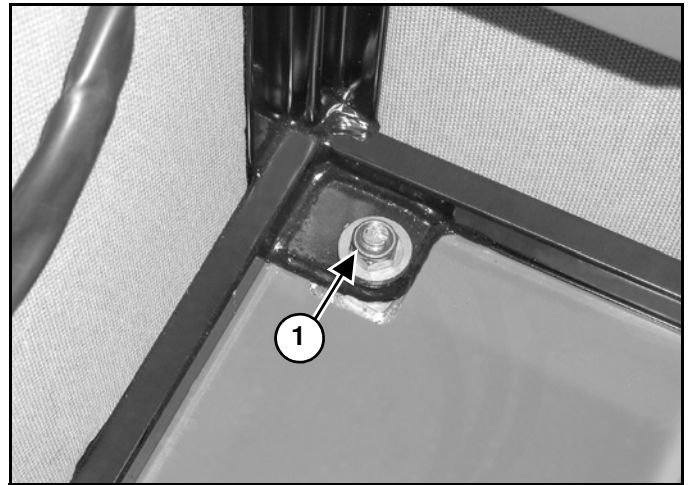
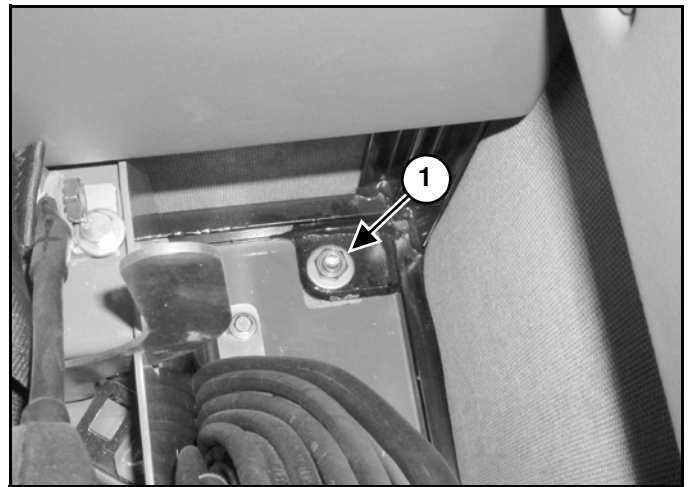

Figure 40-20-18



Remove the rear cab mount nuts (Item 1) [Figure 40-20-17] & [Figure 40-20-18] and washers.

Installation: Tighten the nuts to 81-92 ft.-lb. (110-125 Nm) torque.

CAB (CONT'D)

Front Window Disassembly And Assembly (Cont'd)

Figure 40-20-49

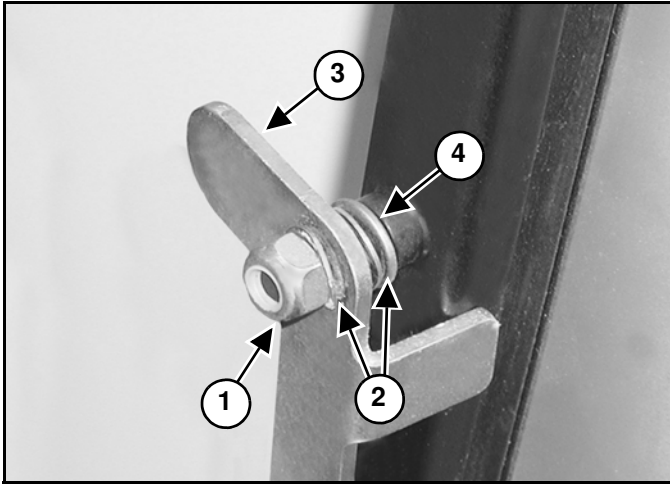

Remove the lock nut (Item 1), wave washers (Item 2) latch (Item 3), and washer (Item 4) [Figure 40-20-49] (Both Sides)

Figure 40-20-50

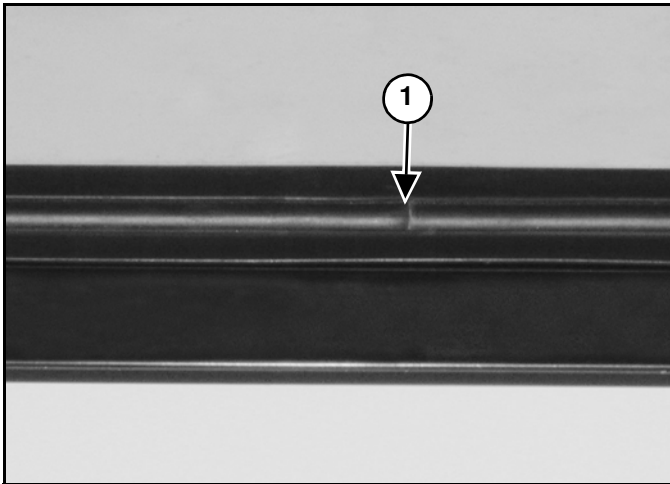

Locate the end of the rubber cord (Item 1) [Figure 40-20-50].

Figure 40-20-51

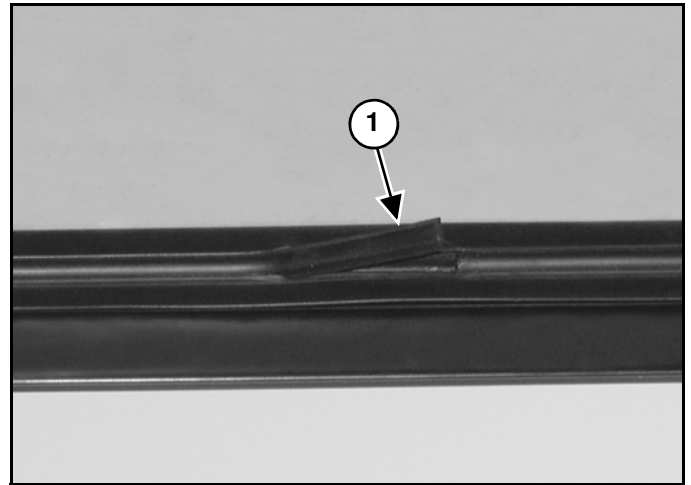

Remove the rubber cord (Item 1) [Figure 40-20-51].

Installation: Install the rubber cord with the rounded side facing out. Do not stretch or cut the rubber cord during installation. The cord will shrink to its original length leaving a gap.

Figure 40-20-52

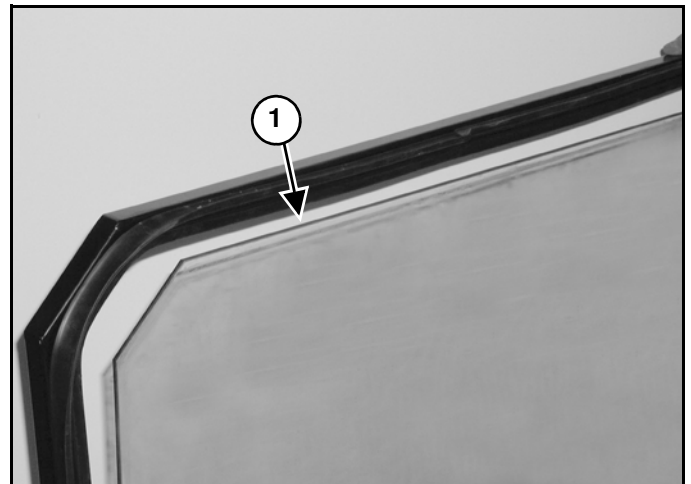

Remove the window (Item 1) [Figure 40-20-52].

SEAT AND SEAT MOUNT

Removal And Installation

Figure 1

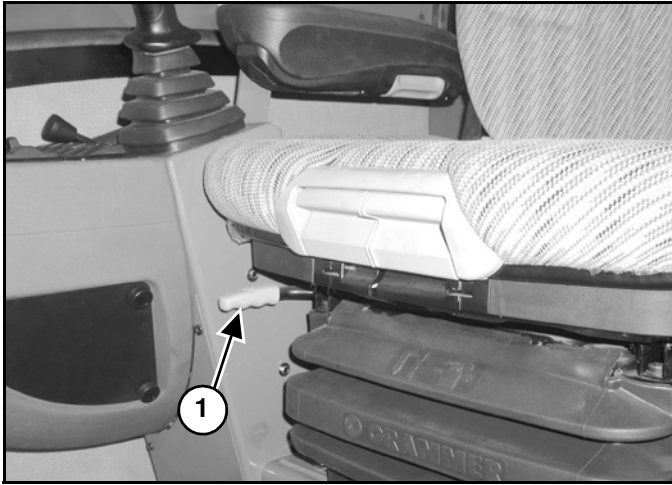

Pull the slide handle (Item 1) **[Figure 1]** up and slide the seat forward, off of the seat rails.

Figure 40-30-2

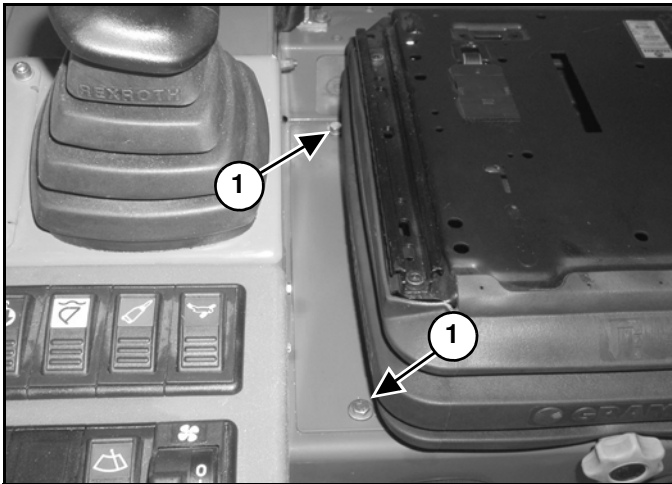
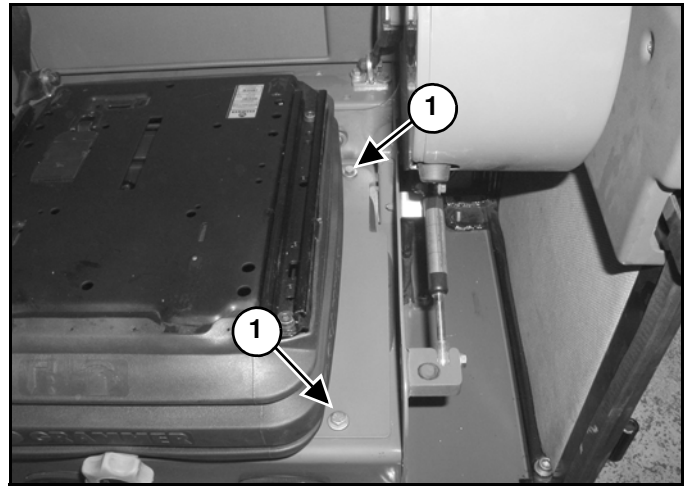

Figure 40-30-3



Remove the four bolts (Item 1) **[Figure 40-30-2]** & **[Figure 40-30-3]** and washers from the seat mount.

LEFT CONSOLE (CONT'D)

Disassembly And Assembly (Cont'd)

Figure 40-50-26

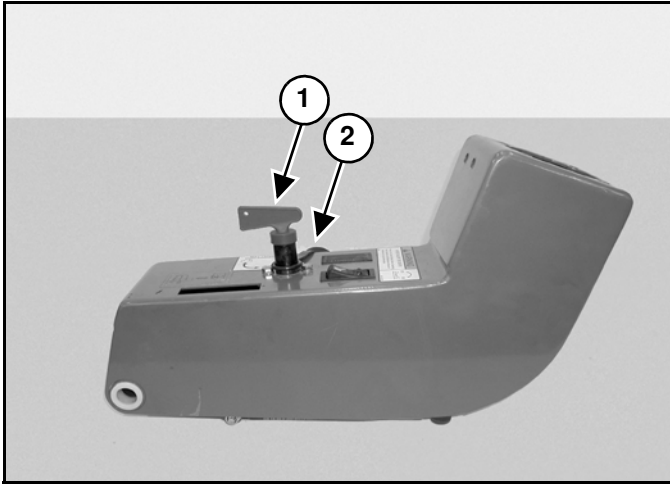

Remove the key (Item 1) and dust cover (Item 2) [Figure 40-50-26] from the battery disconnect.

Figure 40-50-27

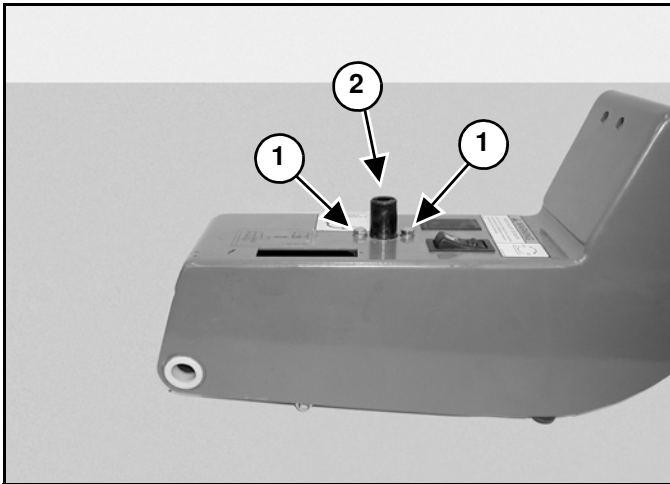

Remove the two screws (Item 1) from the battery disconnect (Item 2) [Figure 40-50-27].

Remove the battery disconnect.

Figure 40-50-28

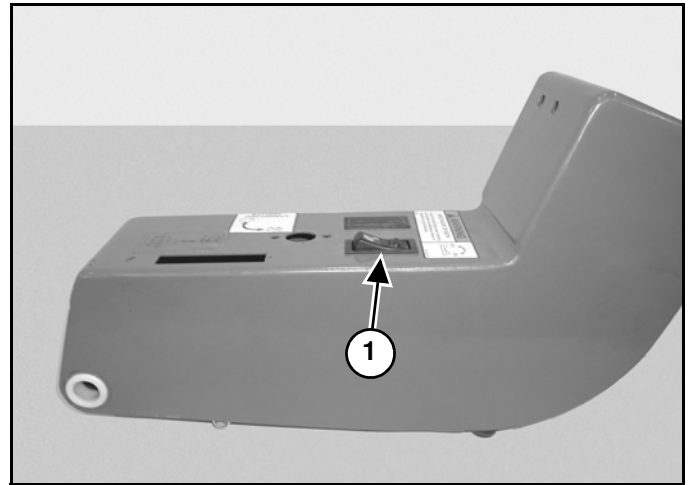

Remove the switch (Item 1) [Figure 40-50-28].

Figure 40-50-29

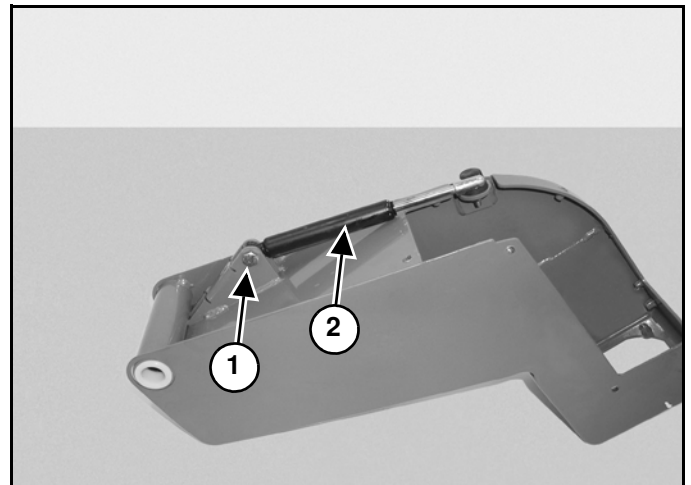

Remove the bolt (Item 1), washer, and nut from the gas strut (Item 2) [Figure 40-50-29].

Remove the gas strut.

FUEL TANK (CONT'D)

Removal And Installation (Cont'd)

Figure 40-80-9

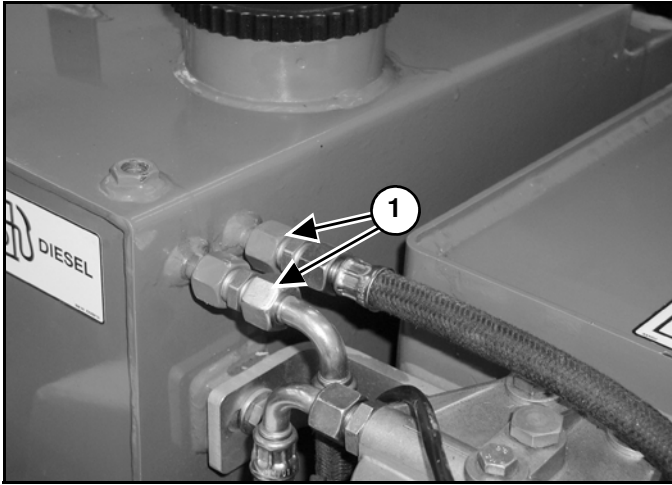

Mark and remove the hoses (Item 1) [Figure 40-80-9].

Install caps and plugs.

Figure 40-80-10

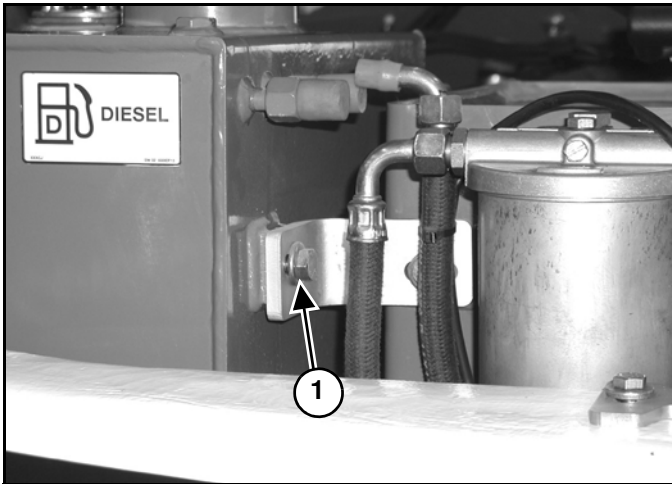

Remove the bolt (Item 1) [Figure 40-80-10] and washer from the mount bracket.

Figure 40-80-11

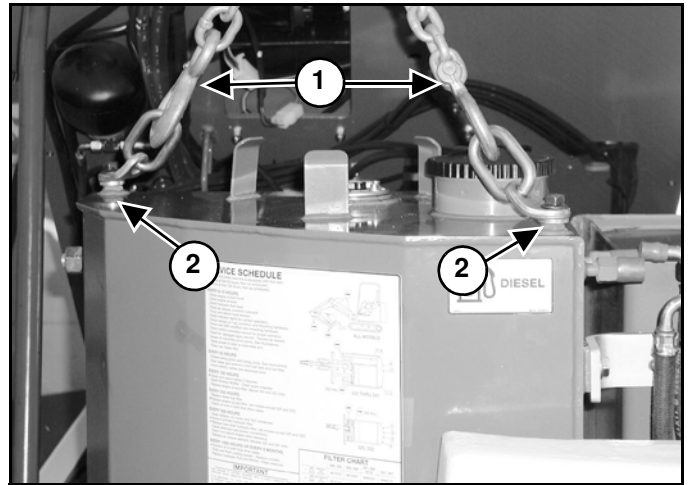

Install a hoist (Item 1) using the threaded holes (Item 2) [Figure 40-80-11].

Figure 40-80-12

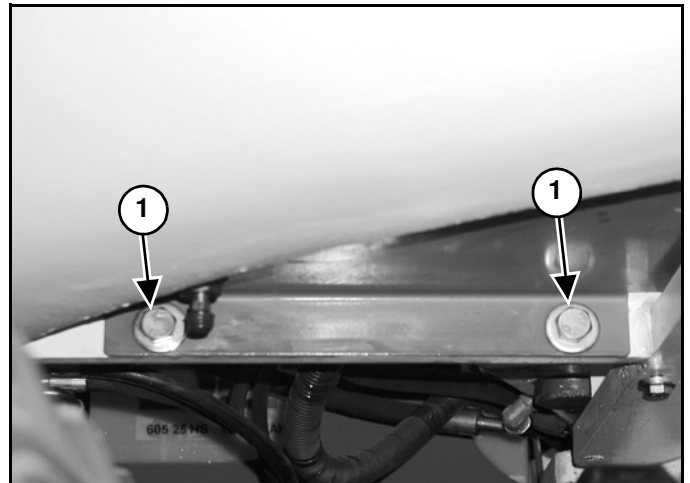

Remove the two bolts (Item 1) [Figure 40-80-12] and washers from the bottom of the fuel tank.

Raise the hoist and remove the fuel tank.

FLOOR MAT

Removal And Installation

Figure 40-110-1



Pull up on and remove the floormat (Item 1) [Figure 40-110-1].

ARM

Removal And Installation

Remove the bucket. (See BUCKET on Page 40-140-1.)

Lower the boom/arm to the ground.

Figure 1



Support the boom with a chain hoist (Item 1) [Figure 1].

With the engine off, the start key in the run position and the left console lowered, move the joysticks to relieve hydraulic pressure.

Figure 40-170-2

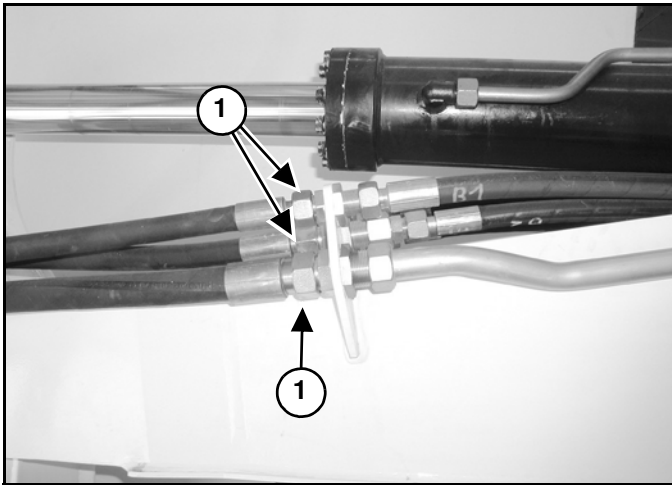
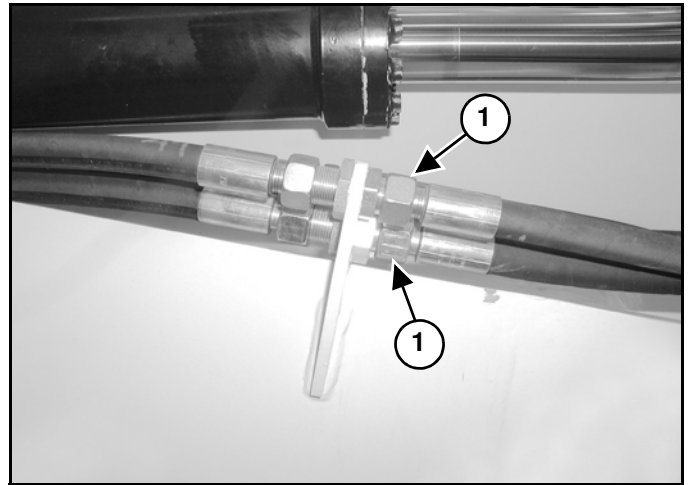

Figure 40-170-3



Remove the bucket/auxiliary hoses (Item 1) [Figure 40-170-2] & [Figure 40-170-3] from both sides of the boom.

RIGHT SIDE COVER (CONTI)

Removal And Installation (Contid)

Figure 40-160-16

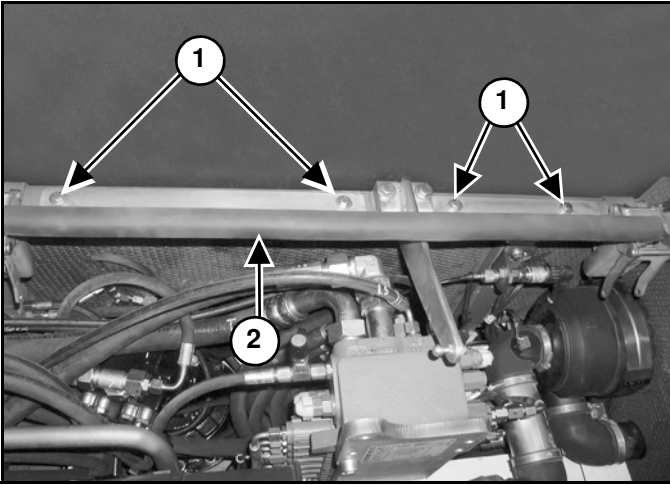

Remove the four bolts (Item 1) and washers from the dust seal (Item 2) [Figure 40-160-16].

Remove the dust seal.

Figure 40-160-17

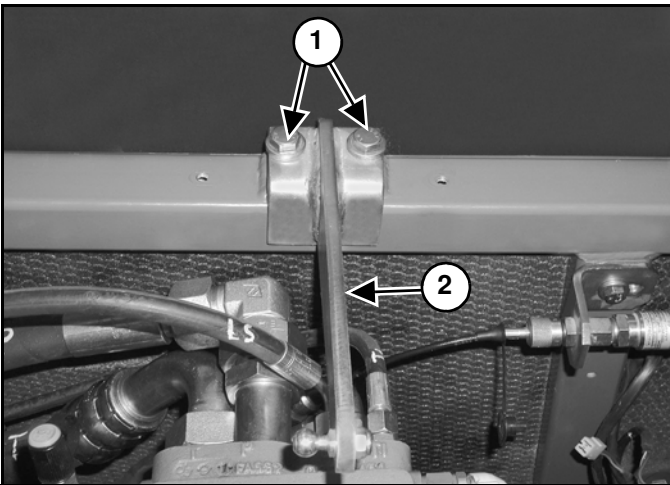

Remove the two bolts (Item 1) and washers from the bracket (Item 2) [Figure 40-160-17].

Remove the bracket.

Remove the right side cover.

ELECTRICAL SYSTEM INFORMATION (CONT'D)

Fuse And Relay Location

Figure 50-10-3

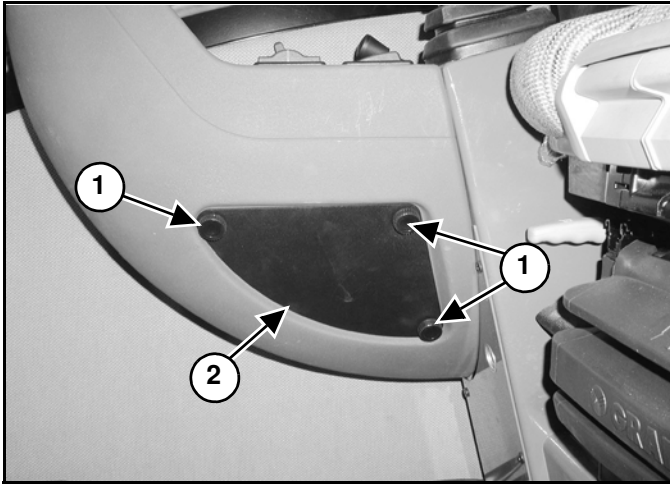

To check or replace the fuses in the right console, remove the three screws (Item 1) and remove the cover (Item 2) [Figure 50-10-3].

Figure 50-10-4

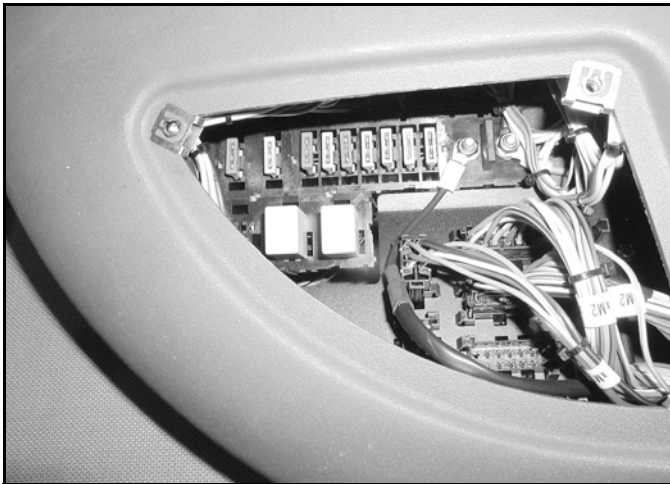
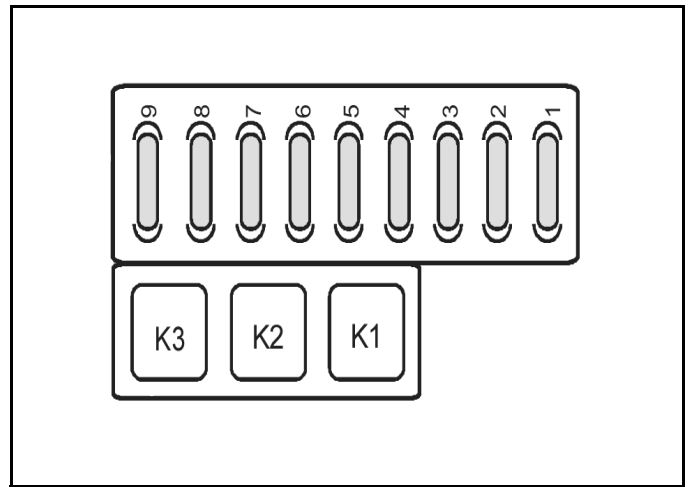

Figure 50-10-5



The location and sizes are shown below and [Figure 50-10-4] & [Figure 50-10-5].

REF.	DESCRIPTION	AMPERAGE.
1	Interior light, radio	5
2	Auxiliary power outlet	20
3	Front lights	15
4	Rear work lights	15
5	Horn	10
6	Heater fan motor	15
7	Wiper/Washer	10
8	Control module signal input	5
9	Optional work lights and heating	
K1	Front work lights	relay
K2	Rear work lights	relay
K3	Air conditioning	relay

Always replace fuses with the same type and capacity.

BATTERY (CONTÍD)

Using A Booster Battery (Jump Starting) (Contíd)

Figure 50-20-11

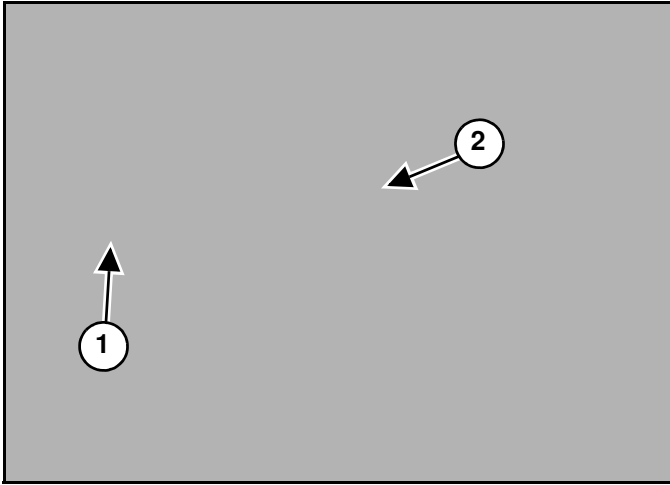

Connect one end of the first cable to the positive (+) terminal of the booster battery. Connect the other end of the same cable to the positive (+) terminal (Item 1) [Figure 50-20-11] of the excavator battery.

Connect the end of the second cable to the negative (-) terminal of the booster battery. Connect the other end of the same cable to the excavator frame (Item 2) [Figure 50-20-11] (away from the battery).

NOTE: See Cold Temperature Starting Procedure, in the correct Operation & Maintenance Manual.

Start the engine. After the engine has started, remove the ground (-) cable first (Item 2) [Figure 50-20-11].

Disconnect the cable from the excavator battery (Item 1) [Figure 50-20-11].

IMPORTANT

If jump starting the excavator from a second machine:

When jump starting the excavator from a battery installed in a second machine is NOT running while using the glow plugs. High voltage spikes from a running machine can burn out the glow plugs.

IMPORTANT

Damage to the alternator can occur if:

- ï Engine is operated with battery cables disconnected.
- ï Battery cables are connected when using a fast charger or when welding on the loader. (Remove both cables from the battery.)
- ï Extra battery cables (booster cables) are connected wrong.

FRONT CAB LIGHT

Removal And Installation

Figure 50-50-1

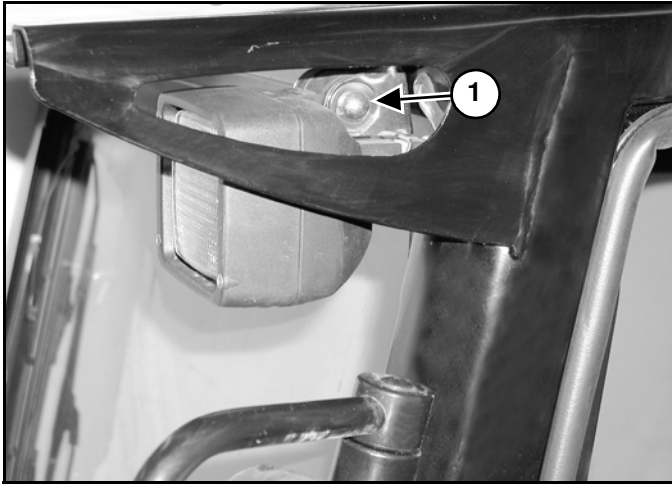

Remove the bolt (Item 1) [Figure 50-50-1] nut and flat washer.

Figure 50-50-2

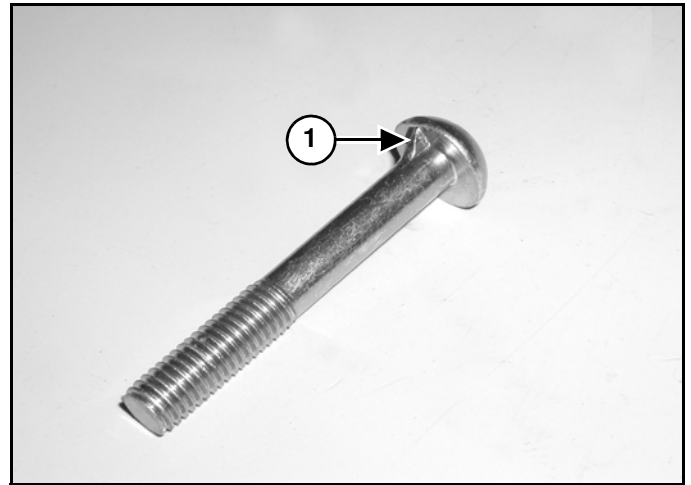
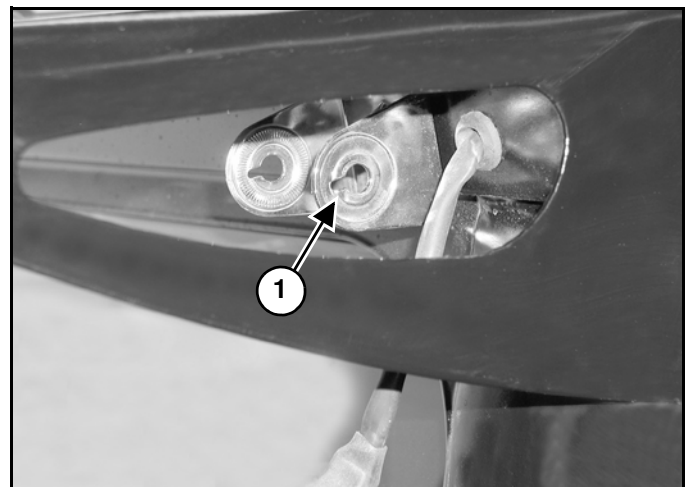

Figure 50-50-3



Installation: Align the notch (Item 1) [Figure 50-50-2] on the bolt with the notch (Item 1) [Figure 50-50-3] in the mount bracket.

Tighten the bolt enough to prevent the light from pivoting in the bracket.

NOTE: Do not overtighten the bolt. The housing may be damaged.

BATTERY DISCONNECT SWITCH

Removal And Installation

Disconnect the battery. (See Servicing on Page 50-20-1.)

Figure 50-90-1

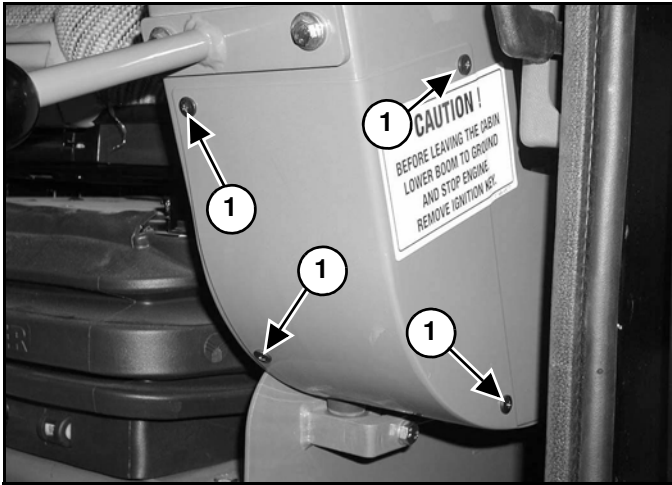

Remove the four screws (Item 1) [Figure 50-90-1].

Raise the left console.

Figure 50-90-2

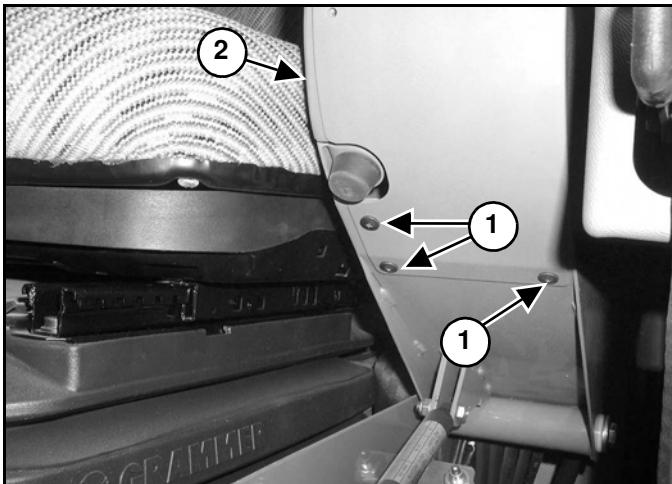

Remove the three screws (Item 1) [Figure 50-90-2].

Remove the lower console cover (Item 2) [Figure 50-90-2].

Figure 50-90-3

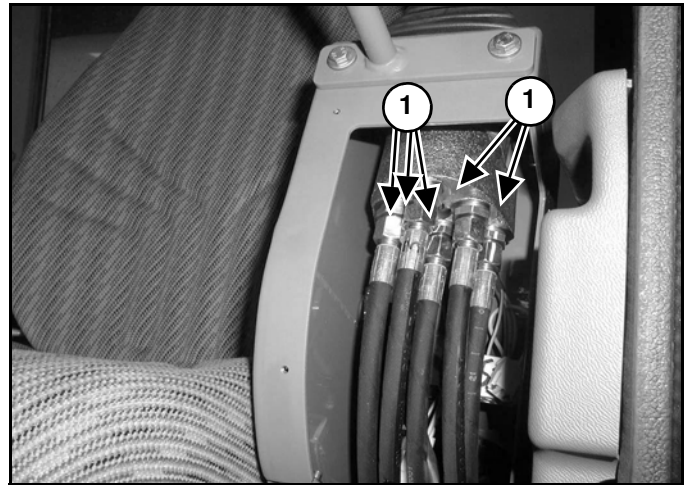

Mark and remove the six hoses (Item 1) [Figure 50-90-3]. Install caps and plugs.

Figure 50-90-4

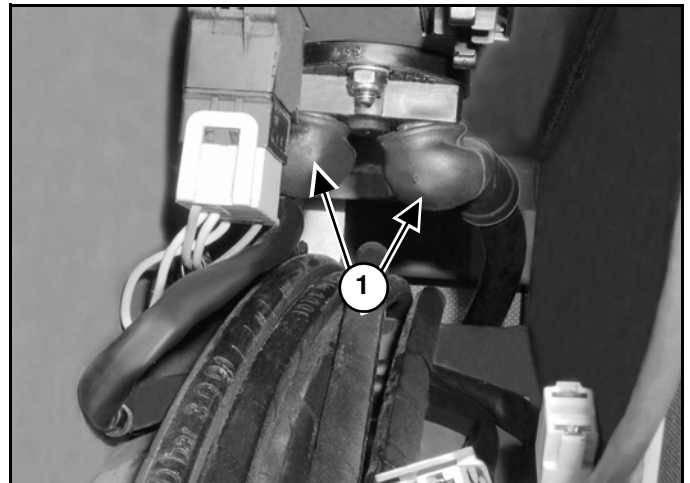

Remove the dust covers (Item 1) [Figure 50-90-4].

AIR CLEANER

Removal And Installation

Open the right side cover.

Figure 60-30-1

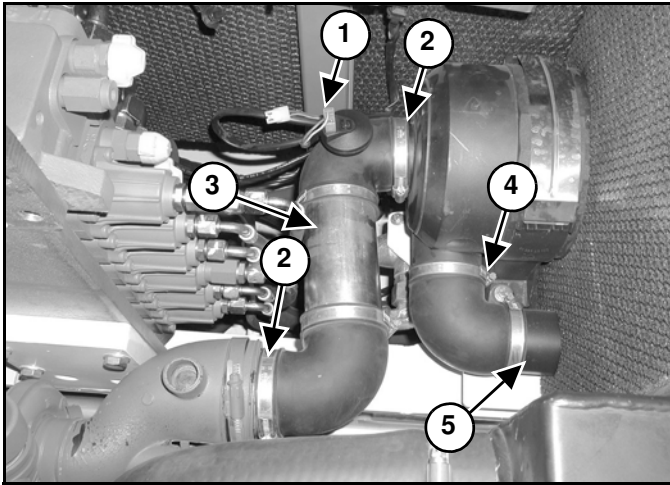

Remove the wire harness (Item 1) [Figure 60-30-1].

Loosen the clamps (Item 2). Remove the tube (Item 3) [Figure 60-30-1] and elbows.

NOTE: Plug the intake to keep contamination out of the engine.

Loosen the clamp (Item 4) and remove the air intake (Item 5) [Figure 60-30-1].

Figure 60-30-2

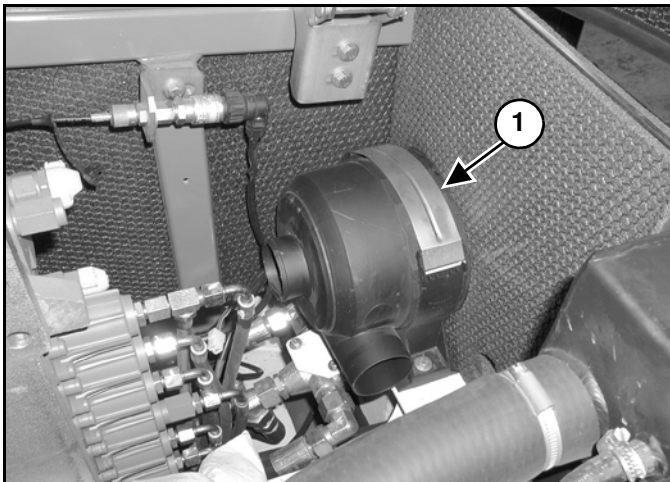

Remove the clamp (Item 1) [Figure 60-30-2].

Figure 60-30-3

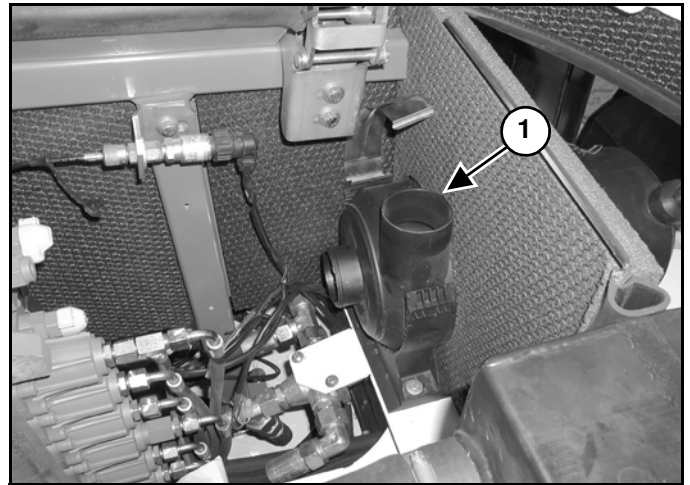
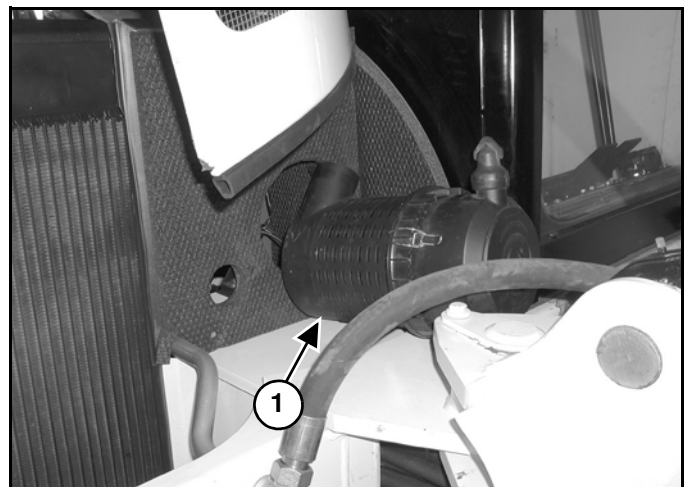

Figure 60-30-4



Slide the air cleaner (Item 1) [Figure 60-30-3] & [Figure 60-30-4] out the front of the excavator.

RADIATOR/OIL COOLER

Removal And Installation (Contid)

Figure 60-41-8

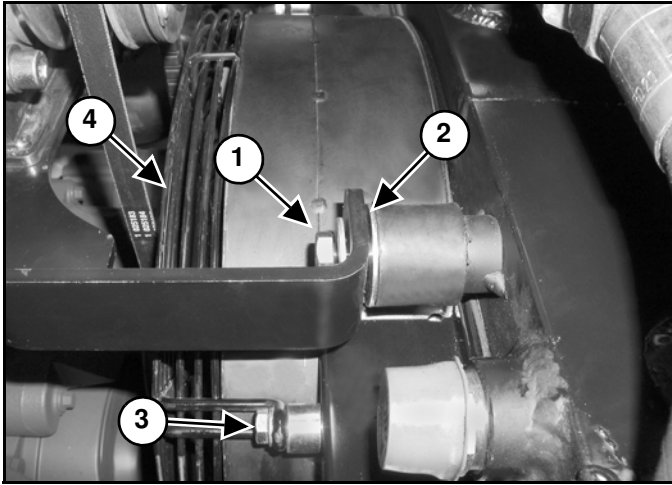

Remove the top bolt (Item 1) and washer. Remove the washer (Item 2) [Figure 60-41-8] from between the mount and bracket.

Remove the four bolts (Item 3) [Figure 60-41-8], washers, and spacers.

Rotate and remove the fan guard (Item 4) [Figure 60-41-8].

Figure 60-41-9

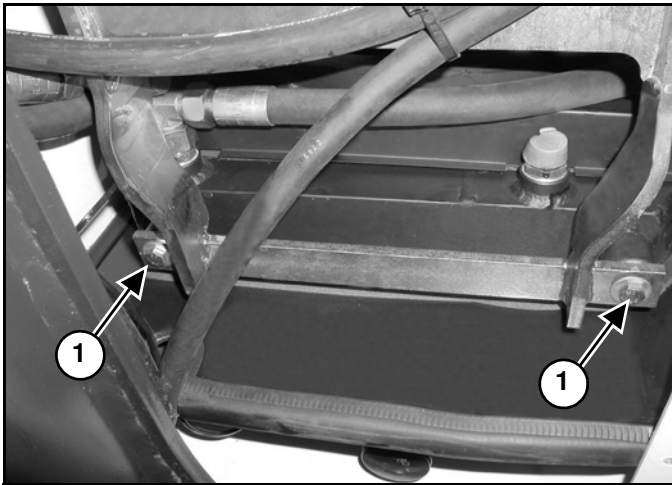

Remove the bolts (Item 1) [Figure 60-41-9] and washers from the bottom of the radiator/oil cooler.

Figure 60-41-10



Tilt the radiator/cooler towards the front of the excavator and position the fan shroud over the fan [Figure 60-41-10].

Figure 60-41-11

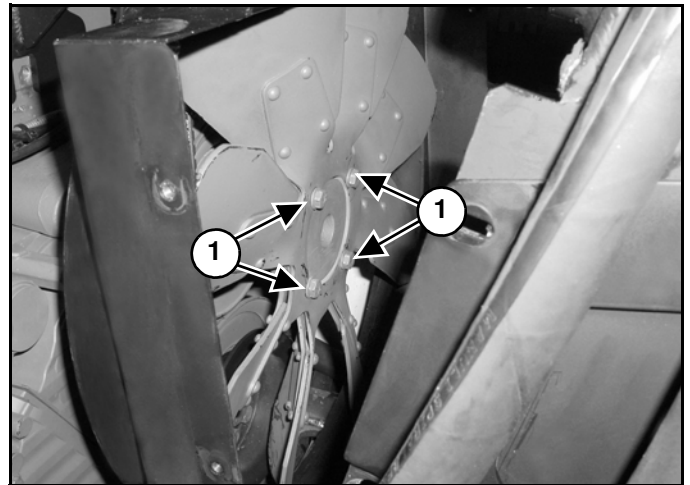

Remove the fan bolts (Item 1) [Figure 60-41-11].

EVAPORATOR/HEATER UNIT (CONT'D)

Removal And Installation (Cont'd)

Figure 70-11-9

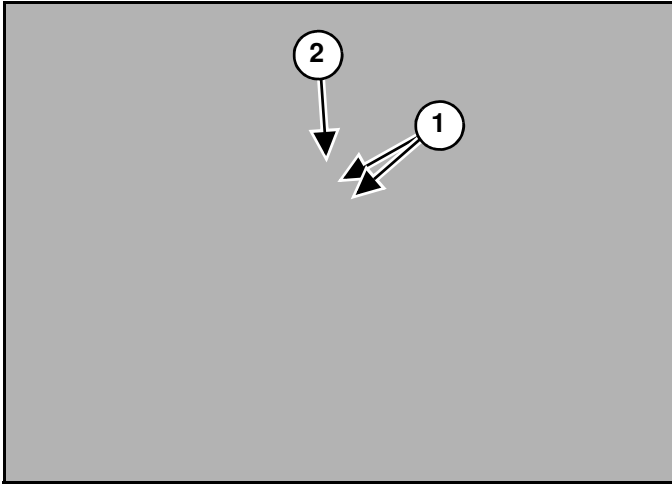

Remove the 2 bolts (Item 1) from the retainer (Item 2) [Figure 70-11-9].

Remove the retainer.

Figure 70-11-10

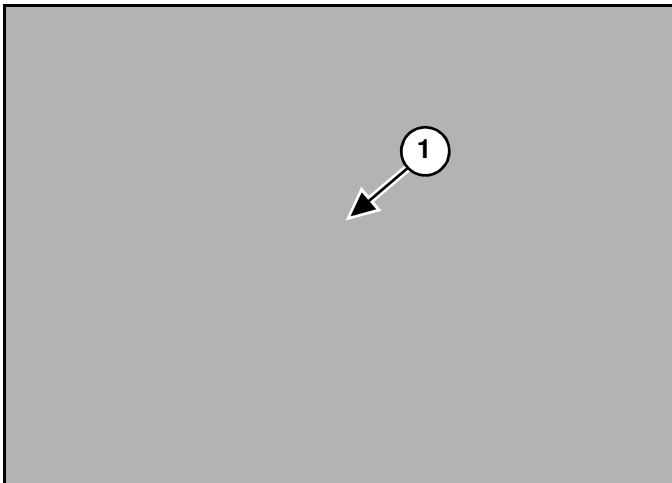

Remove the control cable (Item 1) [Figure 70-11-10].

Figure 70-11-11

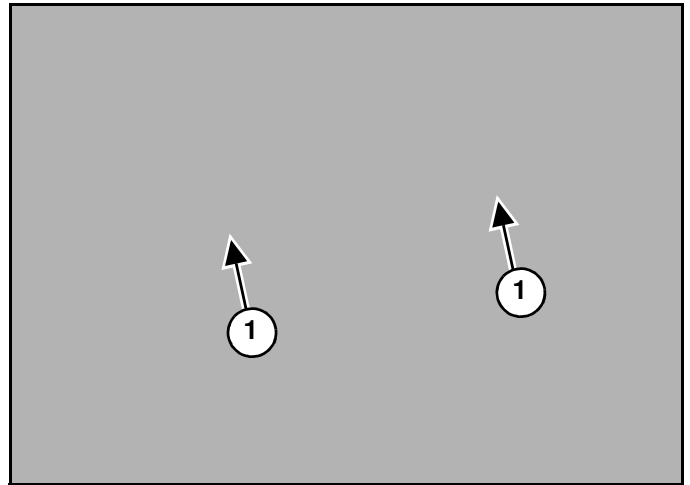

Remove the tiestraps (Item 1) [Figure 70-11-11].

Figure 70-11-12

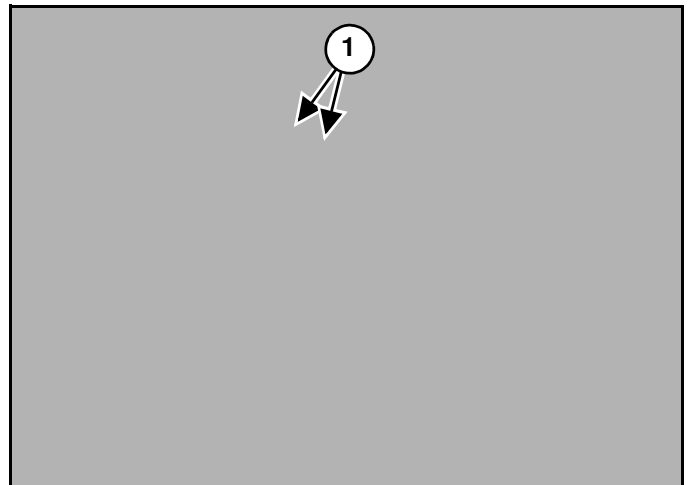

Disconnect the 2 wire connectors (Item 1) [Figure 70-11-12].

HEATER/AC FAN (CONT'D)

Resistor Removal And Installation

NOTE: The resistor removal and installation is shown out of the excavator. The procedure can be done with the evaporator/heater unit installed in the excavator.

Remove the seat and seat mount. (See SEAT AND SEAT MOUNT on Page 40-30-1.)

Figure 70-20-9

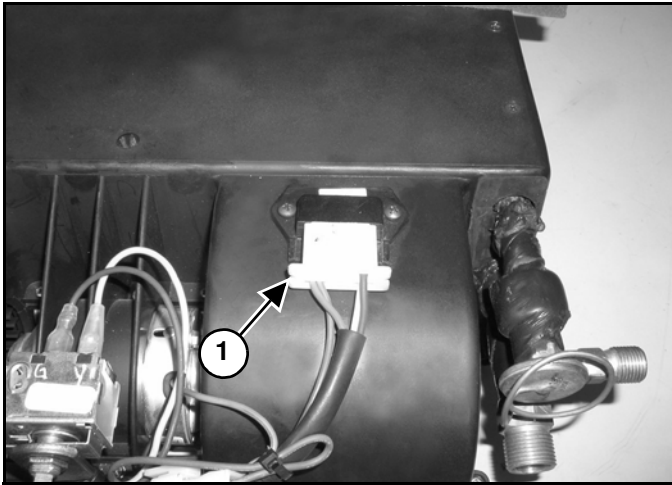

Disconnect the wire harness (Item 1) [Figure 70-20-9]

Figure 70-20-10

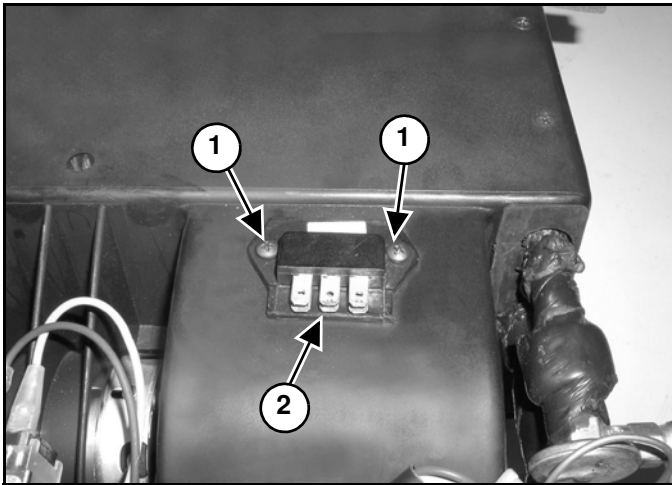

Remove the screws (Item 1) [Figure 70-20-10].

Remove the resistor (Item 2) [Figure 70-20-10].

REGULAR MAINTENANCE

Heater Air Filter

Remove the Heat/AC filter. (See FRESH AIR FILTER on Page 10-62-1.)

Clean the filter by shaking or using low air pressure.

Replace the filter two to four times per year under normal operating conditions, up to weekly under extremely dusty operating conditions.

Air Conditioning Compressor Belt

Open the tailgate.

Figure 70-70-3

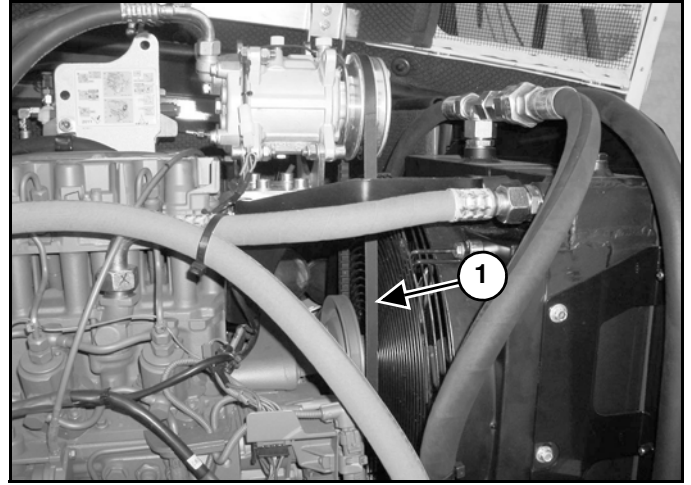
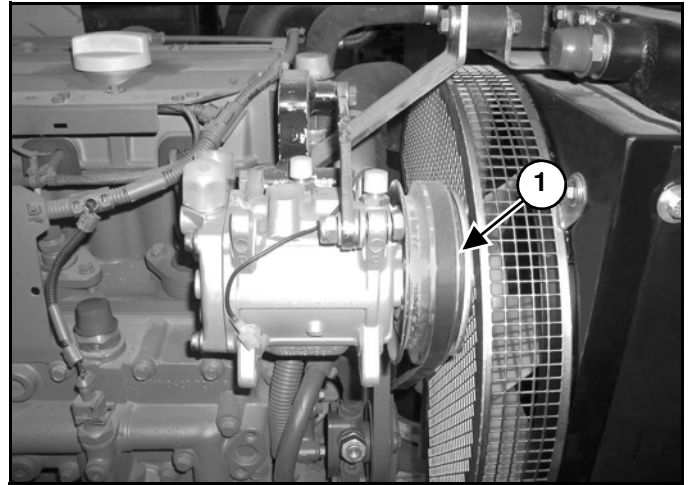

Figure 70-70-4



Check the condition of the belt (Item 1) [Figure 70-70-3] [Figure 70-70-4] and adjust as needed every 100 hours of operation. (See AIR CONDITIONING COMPRESSOR BELT on Page 10-151-1.)

BASIC TROUBLESHOOTING (CONTÍD)

Checking The Electrical System (Contíd)

Figure 70-80-28

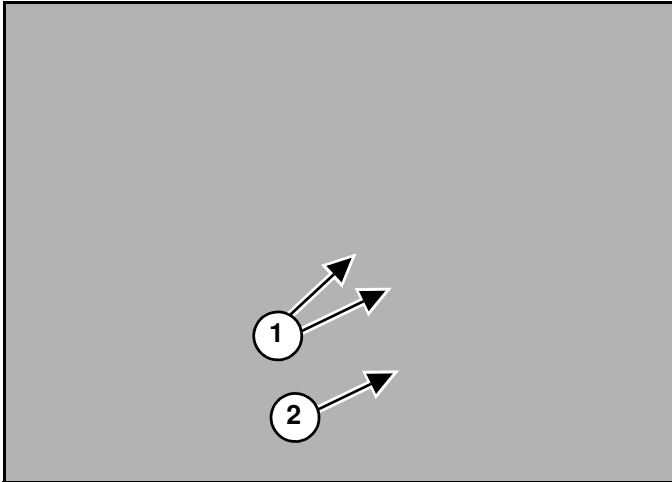

Disconnect the wire harness (Item 1) from the pressure switch (Item 2) [Figure 70-80-28].

Figure 70-80-29

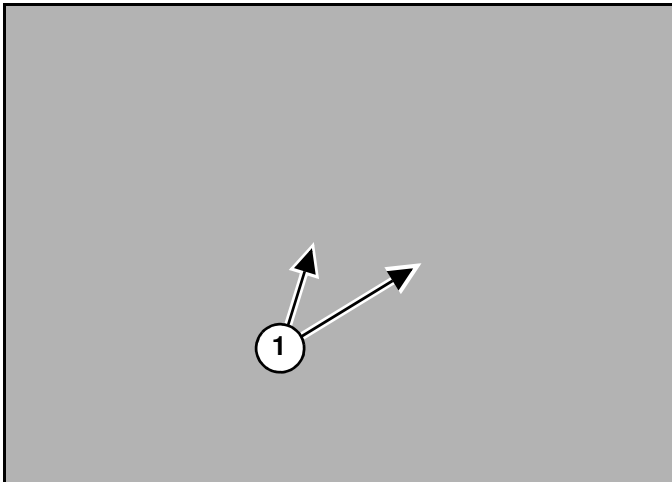

Using a multimeter check the wiring harness (Item 1) [Figure 70-80-29] for voltage.

The voltage should be approximately 12 volts.

Figure 70-80-30

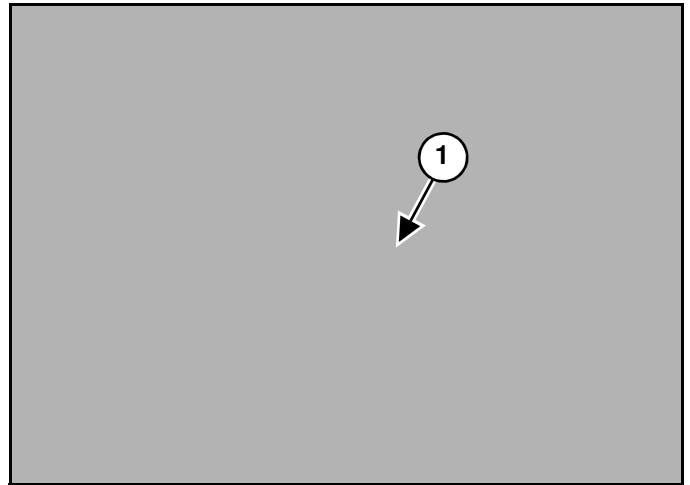

If there is voltage at the harness, check the resistance at the pressure switch (Item 1) [Figure 70-80-30].

If there is no resistance value, check for low or high refrigerant levels in the system. (See Gauge Pressure Related Troubleshooting on Page 70-100-2.)

If a resistance value is observed, the pressure switch is good.

If there is no voltage at the wiring harness check the harness for broken wires. If there are no broken wires, reconnect the wire harness to the pressure switch.

Tilt the cab. (See Tilting The Cab on Page 10-160-2.)

Figure 70-80-31

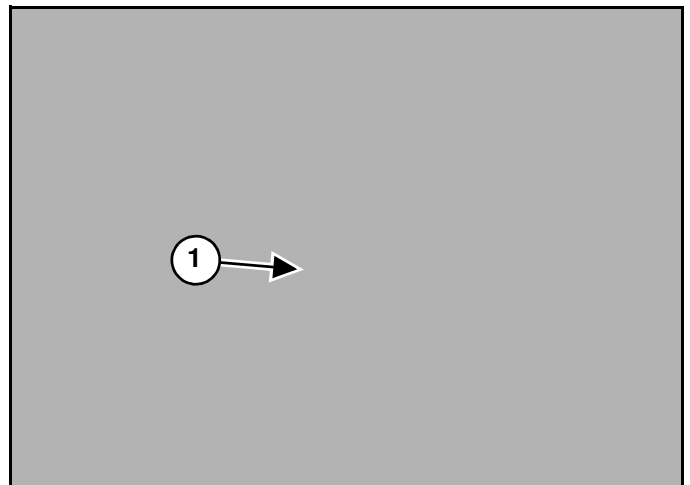

Remove the hose (Item 1) [Figure 70-80-31].

**GENERAL AIR CONDITIONING SERVICE
GUIDELINES (CONT'D)**

Component Replacement And Refrigeration Leaks

Figure 70-90-53

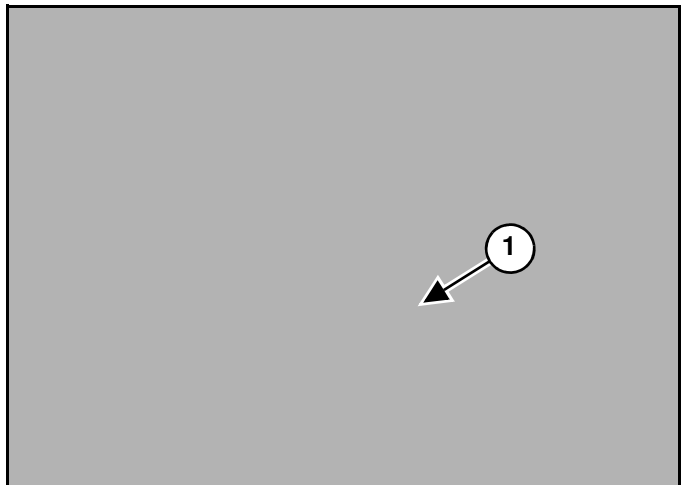

Whenever the A/C system is opened to the atmosphere or there has been a leak in the system, the receiver/drier (Item 1) **[Figure 70-90-53]** must be changed.

Never leave hose fittings, compressor fittings or components uncapped while working on the A/C system.

SYSTEM CHARGING AND RECLAMATION (CONT'D)

Reclamation Procedure (Cont'd)

Figure 70-130-57

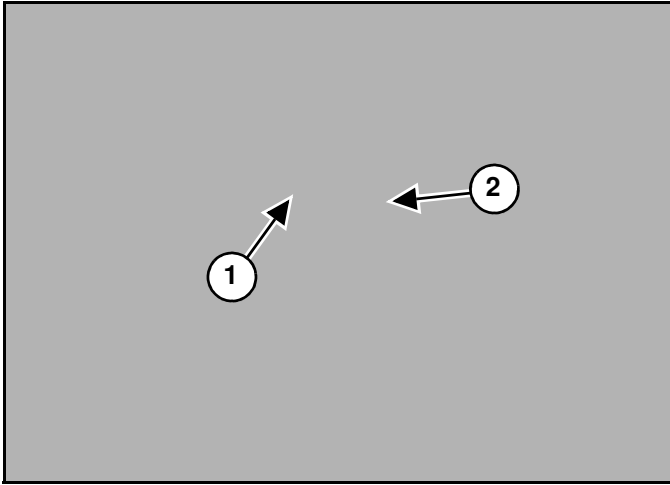

Connect the Red hose (Item 1) [Figure 70-130-57] to the high pressure port and open the valve.

Connect the Blue hose (Item 2) [Figure 70-130-57] to the low pressure port and open the valve.

Figure 70-130-58

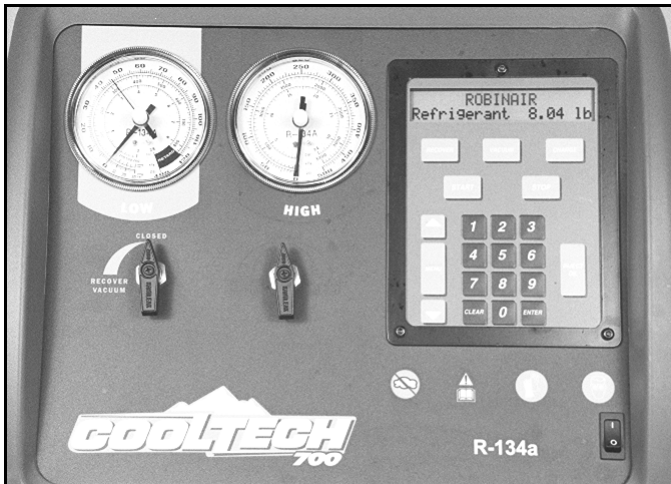

Turn the reclaimer unit [Figure 70-130-58] to the ON position and follow the on screen instructions.

Figure 70-130-59

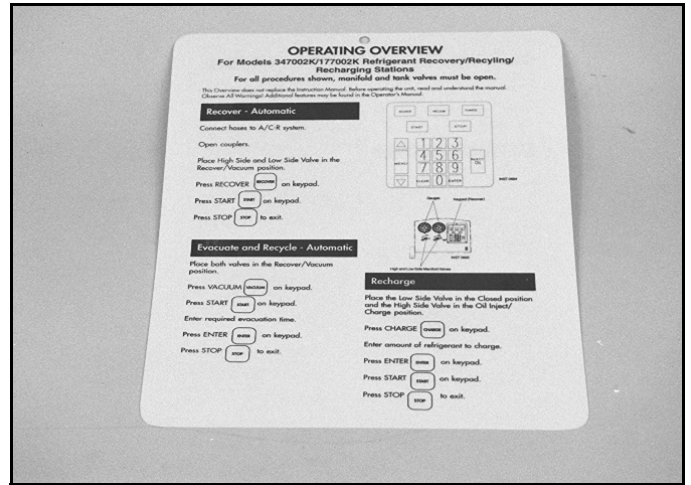

NOTE: The reclaimer unit, has a complete step by step set of instructions [Figure 70-130-59] to follow for reclamation and recharging of the A/C system. A trained technician should follow these instructions as they may very slightly depending on the model and brand of reclaimer used.

The AC system holds 2.64 lbs (1.20 Kg) of refrigerant.

Add 1 oz of Pag oil to the system when a A/C component has been replaced. The compressor comes from the factory pre-filled with oil.

RECEIVER/DRYER

Removal And Installation

Open the right side cover.

Remove the refrigerant from the A/C system. (See SYSTEM CHARGING AND RECLAMATION on Page 70-130-1.)

Figure 70-161-1

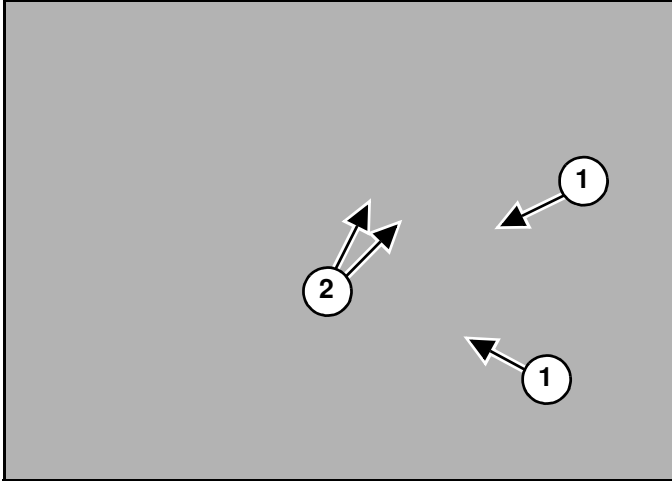

Mark the A/C hoses (Item 1) [Figure 70-161-1] for correct installation.

Remove the hoses.

Plug the hoses with proper A/C plugs.

NOTE: Both fittings on the drier are the same size. The hoses can be installed incorrectly.

WARNING

In the event of a leakage, wear safety goggles. Escaping refrigerant can cause severe injuries to eyes. In contact with a flame, R134a refrigerant gives a toxic gas.

Remove the wire harness (Item 2) [Figure 70-161-1].

Figure 70-161-2

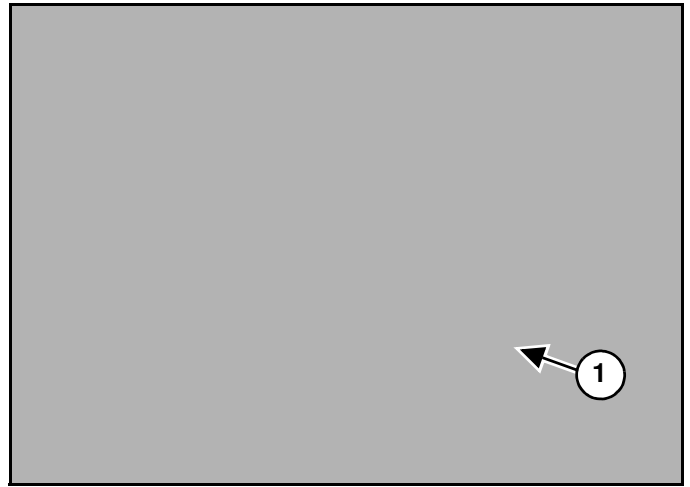

Loosen the clamp (Item 1) [Figure 70-161-2].

Remove the drier.

NOTE: When replacing a receiver/drier, one fluid ounce (30 cc) of PAG oil must be added to the system when recharging.

AIR CONDITIONING SYSTEM (CONT'D)

Thermostat Removal And Installation

Disassemble the evaporator unit. (See Disassembly And Assembly on Page 70-210-4.)

Figure 70-210-24

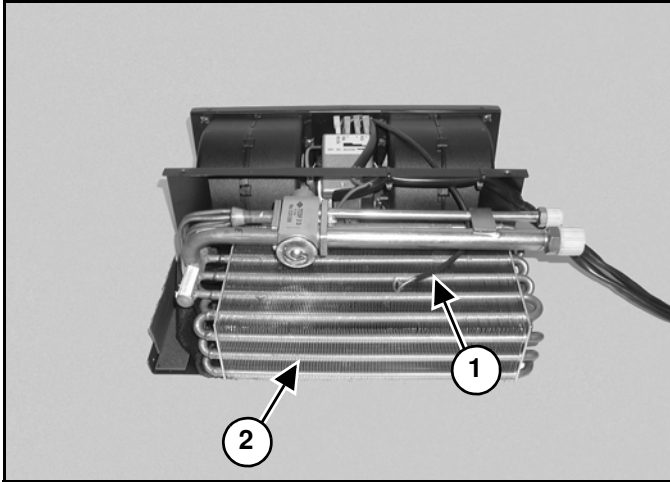

Remove the thermostat (Item 1) from the evaporator (Item 2) [Figure 70-210-24].

Evaporator Removal And Installation

Figure 70-210-25

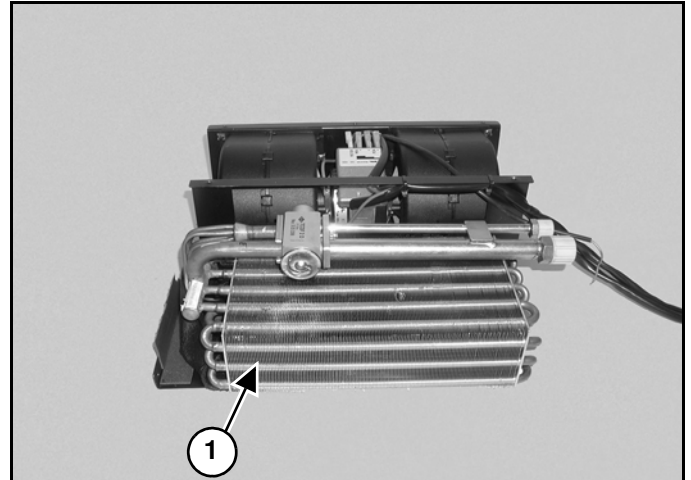

Remove the evaporator (Item 1) [Figure 70-210-25].

Figure 70-210-26

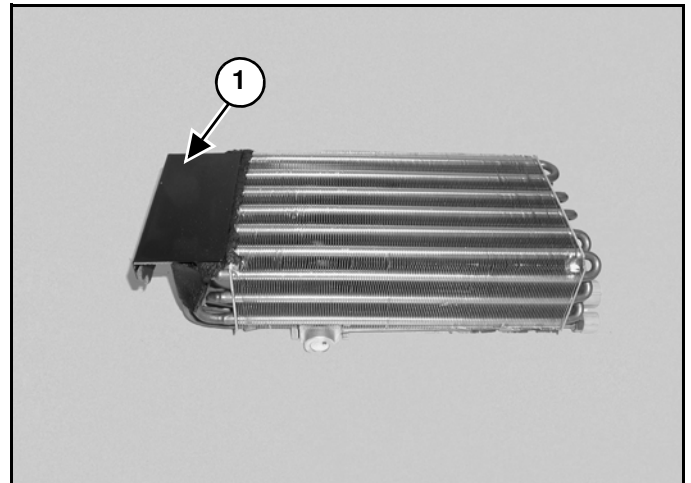

Remove the plate (Item 1) [Figure 70-210-26] from the evaporator.

Working Hydraulics

Working pump (variable displacement pump):	type	A 10 VO 71 DFLR
Displacement:	cm ³ /rev	0 to 71
Gear pumps:	make	Cassapa
Displacement:	cm ³ /rev	14 + 14
LS-regulator (stand-by pressure variable displacement pump):	psi	362
Servo-controlled valve (cross servo control stick):	type	Rexroth 4TH6 N
Servo-controlled valve, pedal (travel):	type	Rexroth 2TH6
Servo-controlled valve, pedal (add. control circuit):	type	Rexroth 2TH6
Valve bank 1: (Mono/Circular boom)	type	6 SX 14 / 7 SX 14
Valve bank 2:	type	3 SM 12

Pressure and Setting Values (Working)

LS-pressure relief valve (6 SX 14):	psi	4061 (valve bank 1)
Main pressure relief valve 1 (6 SX 14):	psi	4351 (safety valve)
Main pressure relief valve 2 (3 SM 12) (high pressure):	psi	3335
Line relief pressures - valve bank 1 (SM 12):		
MONO and circular boom:	psi	2610 / 4351
Intermediate boom:	psi	2610 / 4351
Dipper stick:	psi	4351 / 4351
Bucket:	psi	4351 / 4351
Breaker / additional control circuit:	psi	4351 / 4351
Travel left / travel right:	psi	4061 / 4061 (in motor)
Line relief pressures - valve bank 2 (3SM 12):		
Slewing (valves at the slew motor):	psi	1450 / 3625
Dozer blade:	psi	---
Articulation:	psi	---
Shut-off valve:	make	Bergin
Shut-off pressure (high idle):	psi	1595
Pressure reducing valve (pilot control):	make	Parker
Pilot pressure - high idle	psi	435 ^{±2}

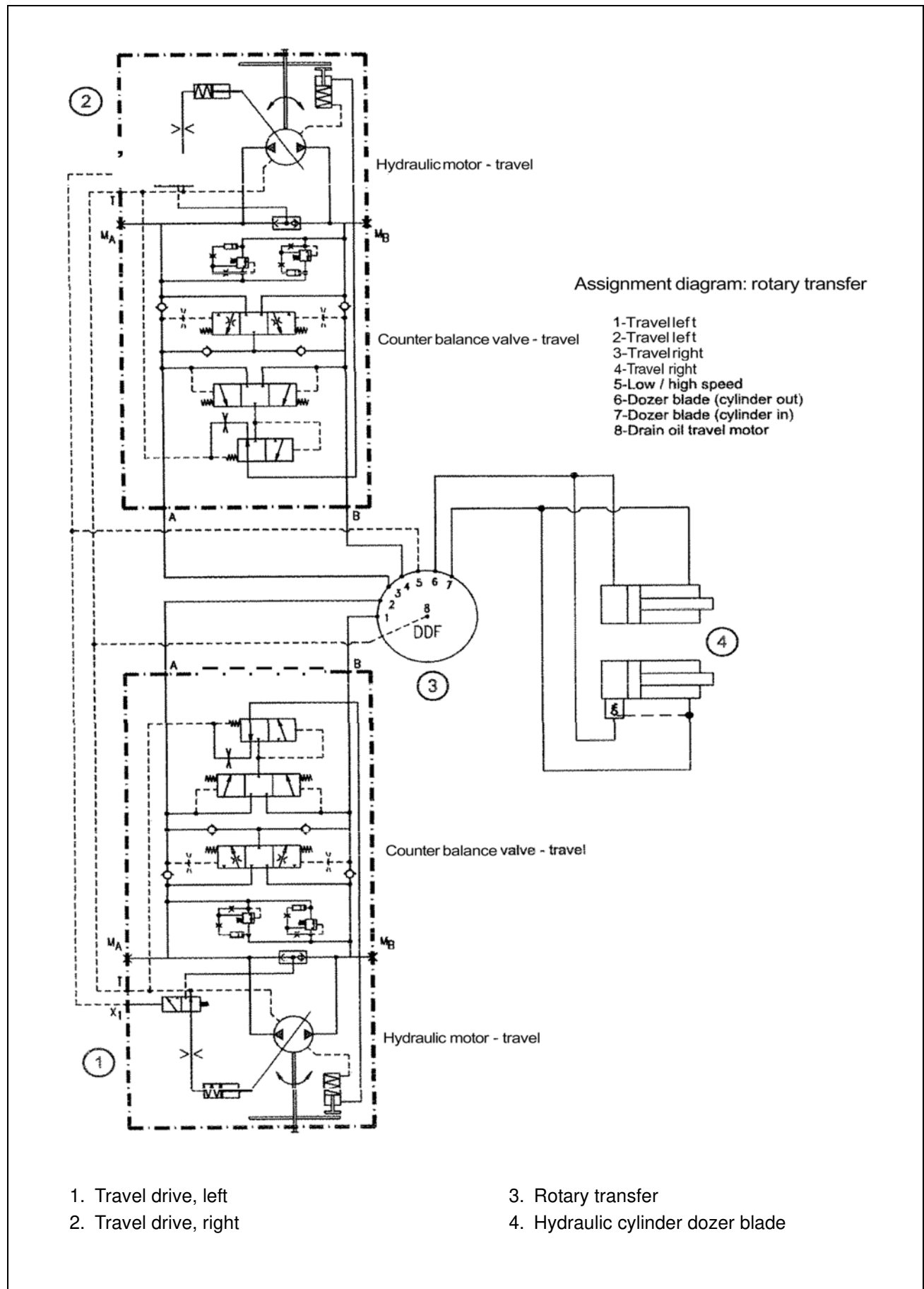

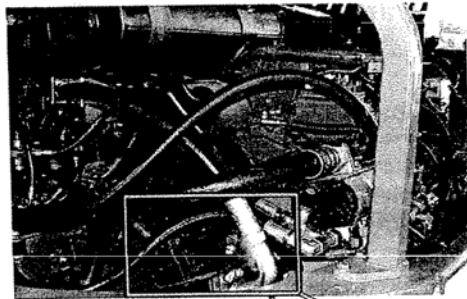

variable displacement pump - working

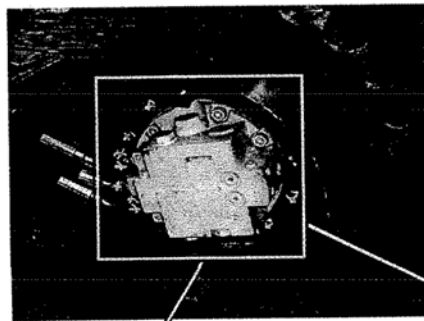
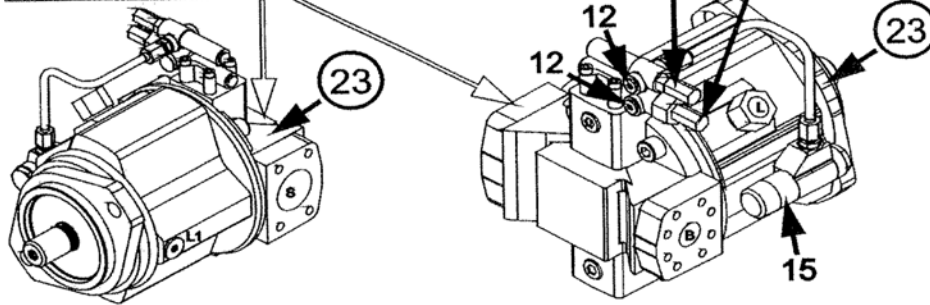

travel drive

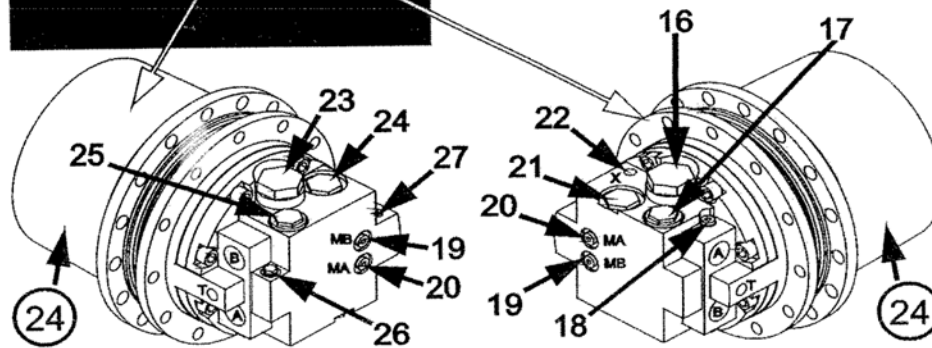

23. Variable displacement pump -working

- Plug (12)
- A_p - pressure valve (13) (power regulator)
- load sensing regulator (14) (setting stand-by pressure)
- power valve (15) (setting at test bench)

24. Travel drive

- plug (16) (counter balance valve)
- check valve (17)
- pressure balance valve (18)
- Plug (19) (test port "MB")
- line relief valve with cushion piston (21) (4061 psi)
- connection "X" (22) (control pressure) fast / slow
- plug (23) (counter balance valve)
- line relief valve with cushion piston (24) (4061 psi)
- check valve (25)
- pressure control valve (26)
- shuttle valve (27)

Working Floodlights

Working Floodlights	Rotating Beacon
---------------------	-----------------

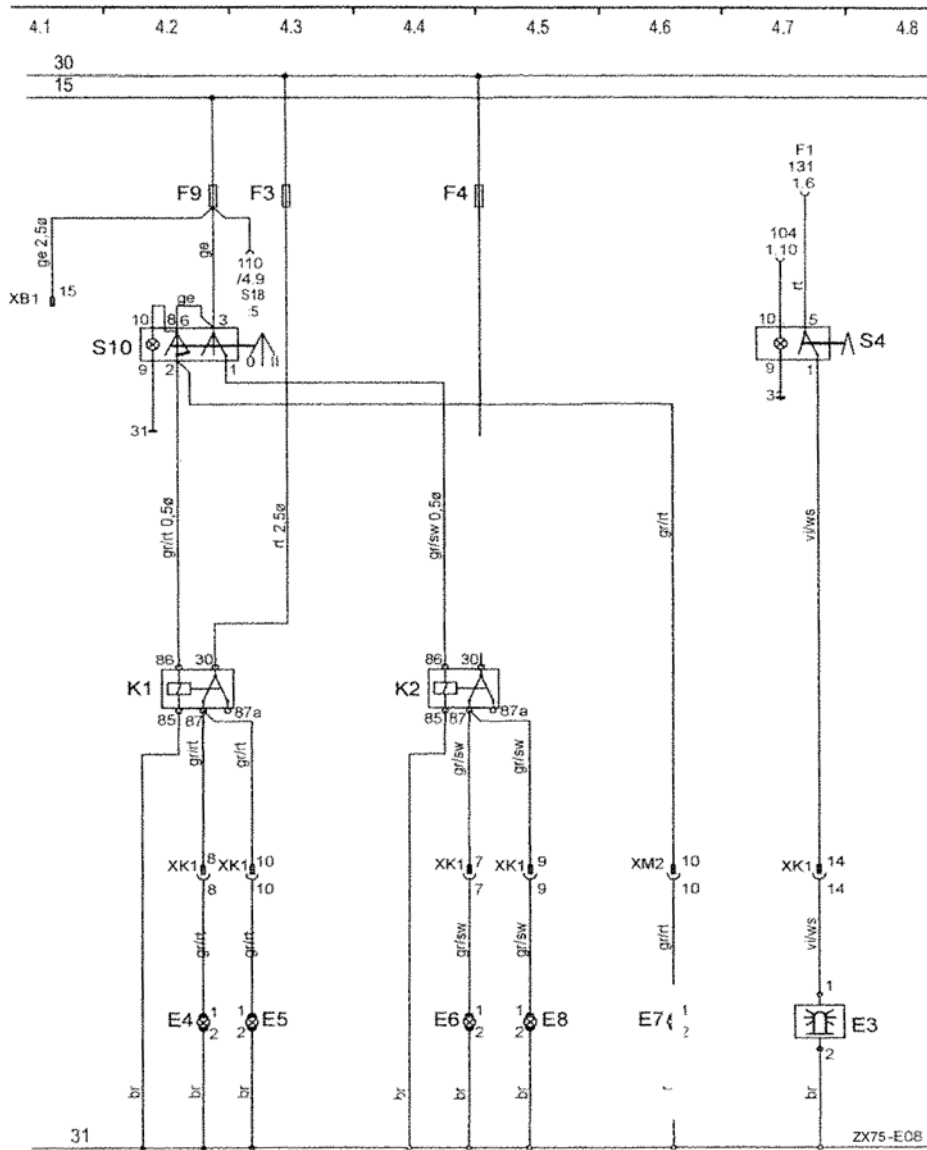

Path	Desig.	Device	Path	Desig.	Device
Working floodlights					
4.2	F9	Fuse	4.4	F4	Fuse
4.2	S10	Working floodlights	4.4	K2	Relay
4.2	K1	Relay	4.4	E6	Working floodlight, rear
4.2	E4	Working floodlight, front	4.5	E8	Working floodlight, rear
4.3	F3	Fuse	4.6	E7	Boom-mounted working floodlight
4.3	E5	Working floodlight, front	4.7	S4	Switch, rotating beacon
			4.7	E3	Rotating beacon

		Desired value		Actual value		Adjusted		Remark
Engine, travel hydraulics, working hydraulics								
Engine, high idle running speed	min ⁻¹	2.150 ⁺⁵⁰						
Engine, low idle running speed	min ⁻¹	800 ⁺⁵⁰						
Pilot pressure	psi	507 ⁺¹						
LS pressure relief valve (SX 14)	psi	5076 ⁺⁵						high idle valve bank 1
Stand-by pressure	psi	319 ^{±1}						high idle
Main pressure relief valve 1 (SX 18)	psi	4351 ⁺⁵						high idle valve bank 1
Main pressure relief valve 2 (5 SM 12)	psi	3335 ⁺⁵						high idle valve bank 2
Shut-off valve	psi	1595 ⁺⁵						
Swing right / left	psi	1450 - 3625 ^{±10}						2-stage valves
Line relief pressures								
		out	in	out	in	out	in	
hydraulic cylinders								
Boom (mono boom)	psi	2175	4351					
Intermediate boom (circular boom)	psi	2175	4351					
Dipperstick	psi	4351	4351					
Bucket	psi	4351	4351					
Add control circuit	psi	4351	4351					
		forward	backward					
Travel, right	psi	4061 ^{±10}	4061 ^{±10}					Valves in travel motor
Travel, left	psi	4061 ^{±10}	4061 ^{±10}					Valves in travel motor
Articulation								
Articulation	psi	---	---					
Dozer blade								
Dozer blade	psi	---	---					

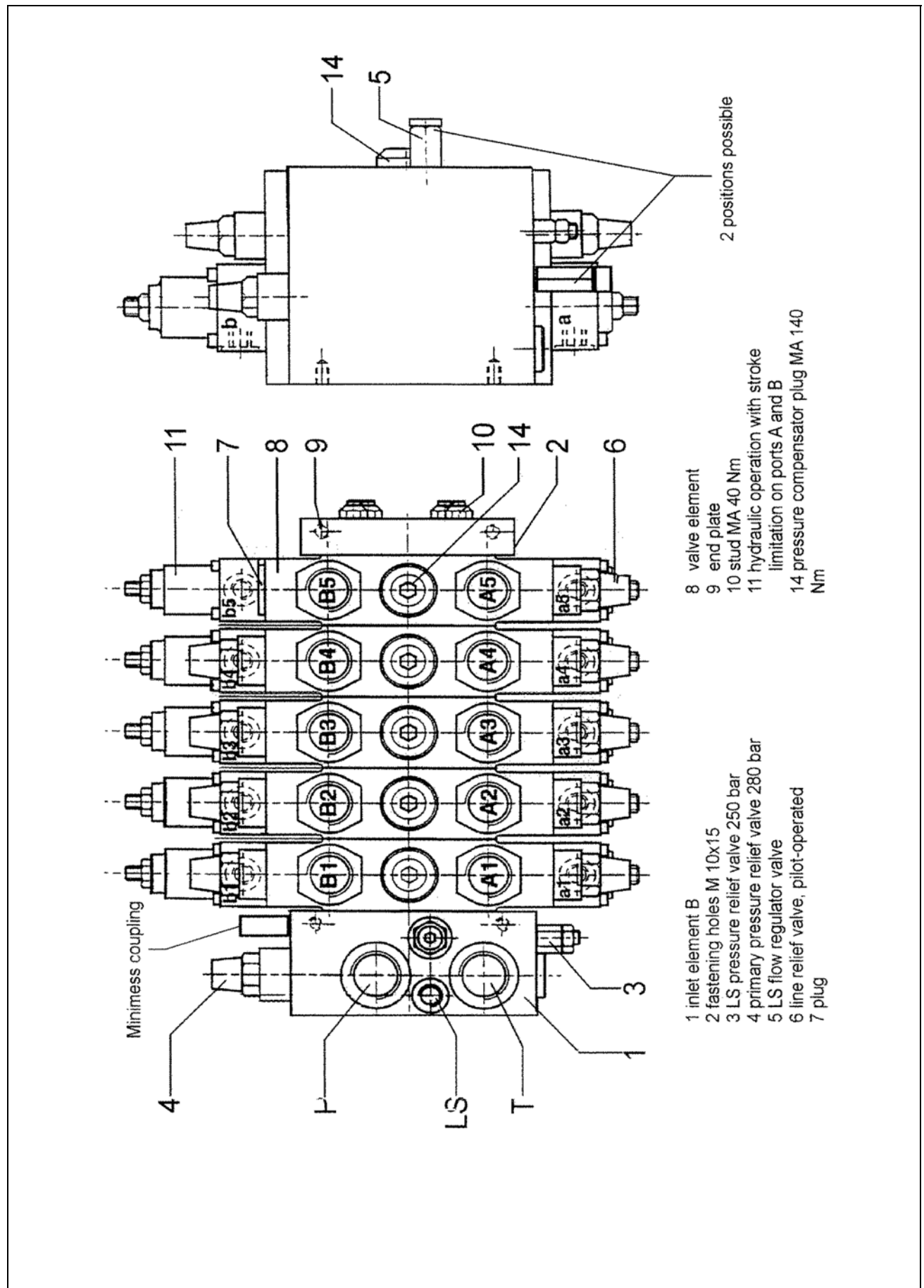

Minimess coupling

- 1 inlet element B
 - 2 fastening holes M 10x15
 - 3 LS pressure relief valve 250 bar
 - 4 primary pressure relief valve 280 bar
 - 5 LS flow regulator valve
 - 6 line relief valve, pilot-operated
 - 7 plug
 - 8 valve element
 - 9 end plate
 - 10 stud MA 40 Nm
 - 11 hydraulic operation with stroke limitation on ports A and B
 - 14 pressure compensator plug MA 140 Nm
- 2 positions possible

Load Warning Device

Load Warning Device	Travel	Float Position	Rock Breaker
---------------------	--------	----------------	--------------

3.1	3.2	3.3	3.4	3.5	3.6	3.7	3.8	3.9
30								
15								

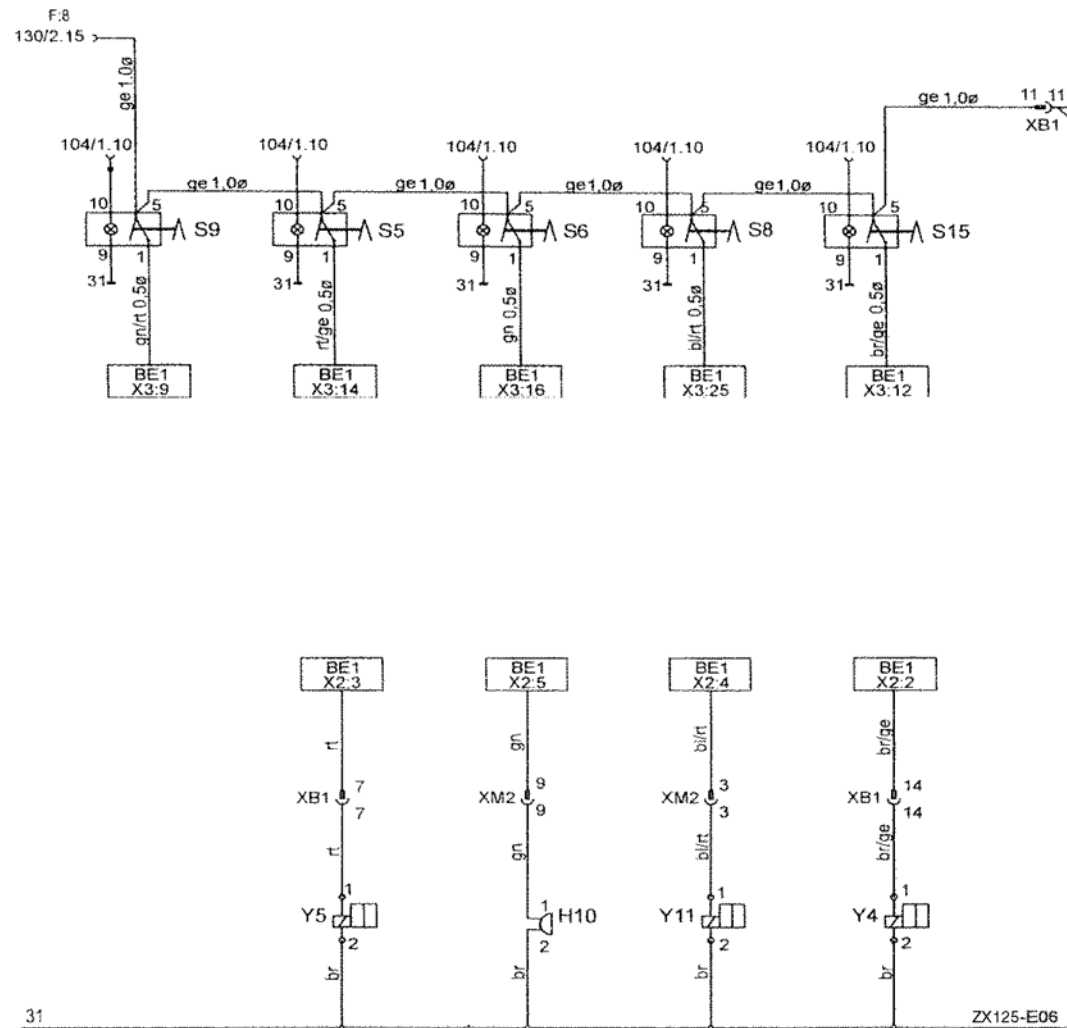

Path	Desig.	Device	Path	Desig.	Device
Load warning device			Float position		
3.2	S9	Shut-off load warning device	3.6	S8	Float position
Travel			3.6	Y11	Float position valve
3.3	S5	FAST-SLOW	Rock breaker		
3.4	Y5	Valve, fast	3.15	S14	Rock breaker
3.5	S6	Travel motion alarm	3.15	Y12	Rock breaker valve
3.5	H10	Travel motion alarm			

CLICK HERE TO **DOWNLOAD** THE COMPLETE MANUAL

- Thank you very much for reading the preview of the manual.
- You can download the complete manual from: www.heydownloads.com by clicking the link below



- Please note: If there is no response to **CLICKING** the link, please download this PDF first and then click on it.

CLICK HERE TO **DOWNLOAD** THE COMPLETE MANUAL