FOREWORD





This Arctic Cat Service Manual contains service, maintenance, and troubleshooting information for certain 2007 Arctic Cat ATV models (see cover). The complete manual is designed to aid service personnel in service-oriented applications.

Arctic Cat offers additional publications (when they become available) to aid in servicing other ATV models. To service models not included in this manual, please refer to the following publications:

- **2007 Y-12 Service Manual**
- **2007 DVX/Utility 250 Service Manual**
- **2007 DVX 400 Service Manual**
- **2007 Prowler Service Manual**
- **2007 700 Diesel Service Manual**

This manual is divided into sections. Each section covers a specific ATV component or system and, in addition to the standard service procedures, includes disassembling, inspecting, and assembling instructions. When using this manual as a guide, the technician should use discretion as to how much disassembly is needed to correct any given condition.

The service technician should become familiar with the operation and construction of each component or system by carefully studying the complete manual. This manual will assist the service technician in becoming more aware of and efficient with servicing procedures. Such efficiency not only helps build consumer confidence but also saves time and labor.

All Arctic Cat ATV publications and decals display the words Warning, Caution, Note, and At This Point to emphasize important information. The symbol  **WARNING** identifies personal safety-related information. Be sure to follow the directive because it deals with the possibility of severe personal injury or even death. The symbol  **CAUTION** identifies unsafe practices which may result in ATV-related damage. Follow the directive because it deals with the possibility of damaging part or parts of the ATV. The symbol  **NOTE:** identifies supplementary information worthy of particular attention. The symbol  **AT THIS POINT** directs the technician to certain and specific procedures to promote efficiency and to improve clarity.

At the time of publication, all information, photographs, and illustrations were technically correct. Some photographs used in this manual are used for clarity purposes only and are not designed to depict actual conditions. Because Arctic Cat Inc. constantly refines and improves its products, no retroactive obligation is incurred.

All materials and specifications are subject to change without notice.

Keep this manual accessible in the shop area for reference.

**Product Service and
Warranty Department
Arctic Cat Inc.**

CLICK HERE TO **DOWNLOAD** THE COMPLETE MANUAL

- Thank you very much for reading the preview of the manual.
- You can download the complete manual from: www.heydownloads.com by clicking the link below



- Please note: If there is no response to **CLICKING** the link, please download this PDF first and then click on it.

CLICK HERE TO **DOWNLOAD** THE COMPLETE MANUAL

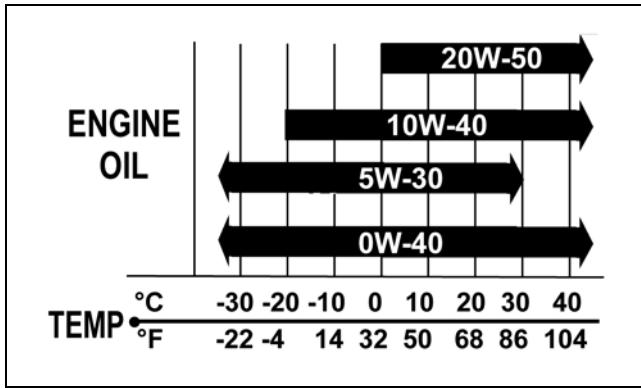

OILCHARTC

RECOMMENDED FRONT DIFFERENTIAL/REAR DRIVE LUBRICANT

The recommended lubricant is Arctic Cat Gear Lube or an equivalent gear lube which is SAE approved 80W-90 hypoid. This lubricant meets all of the lubrication requirements of the Arctic Cat ATV front differentials and rear drives.

CAUTION
Any lubricant used in place of the recommended lubricant could cause serious front differential/rear drive damage.

FILLING GAS TANK

WARNING
Always fill the gas tank in a well-ventilated area. Never add fuel to the ATV gas tank near any open flames or with the engine running. DO NOT SMOKE while filling the gas tank.

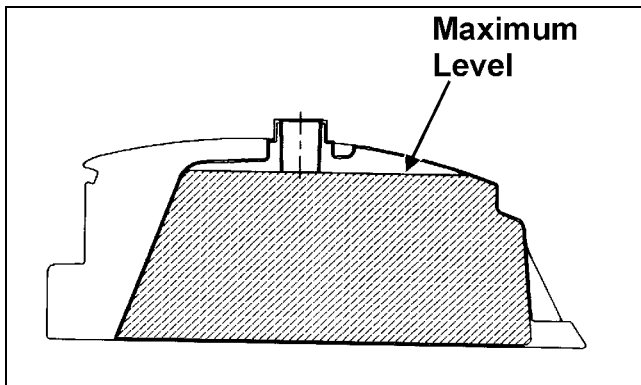

ATV0049B

Since gasoline expands as its temperature rises, the gas tank must be filled to its rated capacity only. Expansion room must be maintained in the tank particularly if the tank is filled with cold gasoline and then moved to a warm area.

WARNING
Do not overflow gasoline when filling the gas tank. A fire hazard could materialize. Always allow the engine to cool before filling the gas tank.

Tighten the gas tank cap securely after filling the tank.

WARNING
Do not over-fill the gas tank.

1

Genuine Parts

When replacement of parts is necessary, use only genuine Arctic Cat ATV parts. They are precision-made to ensure high quality and correct fit. Refer to the appropriate Illustrated Parts Manual for the correct part number, quantity, and description.

Preparation For Storage

CAUTION
Prior to storing the ATV, it must be properly serviced to prevent rusting and component deterioration.

Arctic Cat recommends the following procedure to prepare the ATV for storage.

1. Clean the seat cushion (cover and base) with a damp cloth and allow it to dry.
2. Clean the ATV thoroughly by washing dirt, oil, grass, and other foreign matter from the entire ATV. Allow the ATV to dry thoroughly. DO NOT get water into any part of the engine or air intake.



F1051

A. Measured tappet clearance from step 4 in vertical column on left.

B. Present shim size horizontal row at the top.

C. Match measured clearance in vertical column with current shim size in horizontal row to find recommended replacement size.

9. Apply engine oil to both surfaces of the tappet shim; then place the shim on the valve with the numbers toward the tappet.

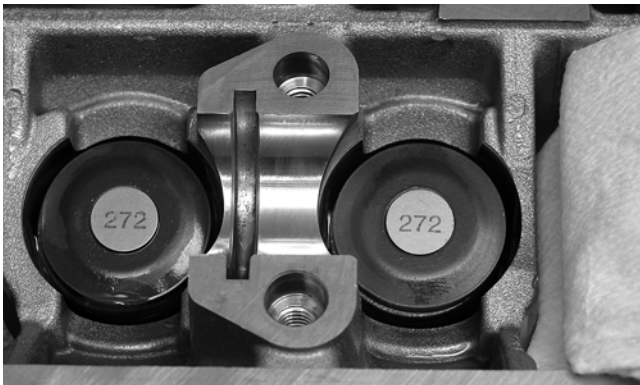

F1053

10. Install the tappet on the appropriate valve; then install the camshaft.

11. Using an appropriate bar, rotate the engine through two full revolutions; then rotate to TDC on the compression stroke and check the valve tappet clearance.

■ **NOTE:** Rotating the engine ensures that any excess oil is squeezed from the tappets and tappet shims. Oil trapped in these areas could result in a false valve clearance reading.

12. Using a new gasket, apply Three Bond Sealant to the camshaft end caps of the cylinder head cover gasket; then install the cylinder head cover and tighten the four cap screws to specifications (see Section 10).

13. Install the valve timing inspection plug and tighten securely; then install the recoil starter assembly and secure with the four cap screws coated with blue Loctite #242. Tighten to specifications (see Section 10).

14. Install the spark plug cap/high tension lead, front fenders, front rack, and splash panels; then install the heat shields and seat making sure the seat locks securely.

Testing Engine Compression

To test engine compression, use the following procedure.

2

1. Remove the high tension lead from the spark plug.
2. Using compressed air, blow any debris from around the spark plug.

⚠ WARNING

Always wear safety glasses when using compressed air.

3. Remove the spark plug; then attach the high tension lead to the plug and ground the plug on the cylinder head well away from the spark plug hole.

⚠ CAUTION

On the 700 EFI, do not ground the spark plug on the cylinder head cover. The cover is made of magnesium and any contact with spark or electrical arc will severely pit the surface.

4. Attach the Compression Tester Kit (p/n 0444-213).

■ **NOTE:** The engine must be warm and the battery must be fully charged for this test.

5. While holding the throttle lever in the full-open position, crank the engine over with the electric starter until the gauge shows a peak reading (five to 10 compression strokes).

■ **NOTE:** For the 400, the compression should be within a range of 95-115 psi in the full-open throttle position. For the 500/650 H1, the compression should be within a range of 70-85 psi in the full-open throttle position. For the 700 EFI, the compression should be within a range of 130-155 psi in the full-open throttle position.

- Remove the left-side splash panel.
- Loosen shift rod end jam nut (A).

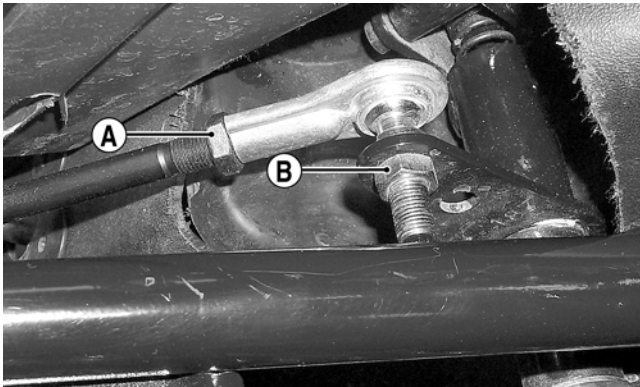

AF941A

- Using two open-end wrenches, remove lock nut (B) securing the shift rod to the upper shift axle. Discard the lock nut.

■ **NOTE: Never reuse a lock nut. Once a lock nut has been removed, it must be replaced with a new lock nut.**

- Push the upper shift axle down completely.
- Rotate the shift rod end as necessary to align its threaded shaft with the hole in the upper shift axle. Secure with a new lock nut (B). Tighten securely.
- Tighten jam nut (A) to secure the adjustment.
- Install the left-side splash panel; then install the seat.
- Loosen the front shift rod jam nut (1) (left-hand threads); then loosen the rear shift rod jam nut (2) (right-hand threads).

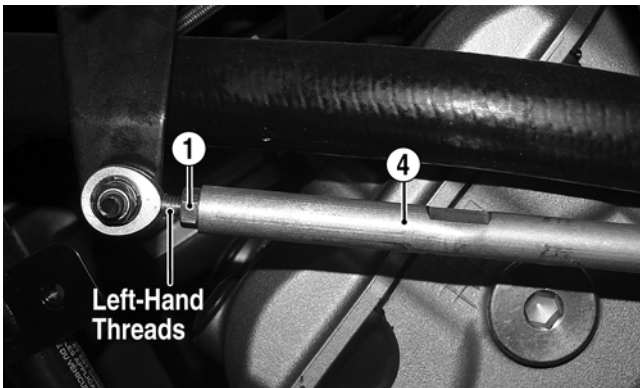

FI059A

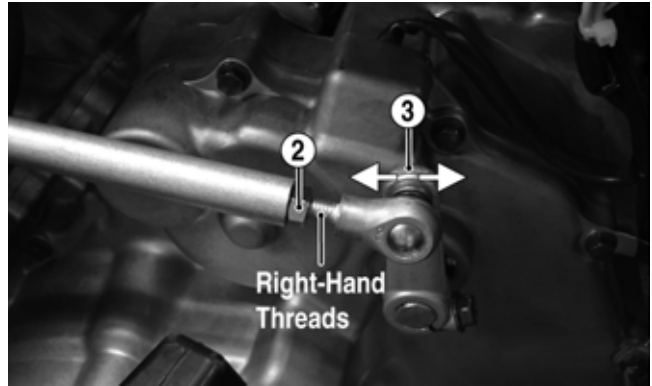

FI010A

- Turn the ignition switch to the ON position; then move the shift arm (3) until the Neutral icon (N) appears on the LCD.
- Rotate the shift rod (4) until the shifter is directly aligned with the Neutral position on the shift gate.
- While holding the shift rod with an open-end wrench, tighten the shift rod jam nuts securely.
- Shift the transmission into each of the remaining positions and verify that the appropriate icon is displayed for the selected gear shift position (H - High, L - Low, and R - Reverse).

■ **NOTE: An E (Error) in the gear position icon indicates no signal or a poor ground wire connection in the circuit. Troubleshoot the harness connectors, gear shift position connector, gear shift position switch, and LCD connector.**

Frame/Welds/Racks

The frame, welds, and racks should be checked periodically for damage, bends, cracks, deterioration, broken components, and missing components. If replacement or repair constitutes removal, see Section 8.

Electrical Connections

The electrical connections should be checked periodically for proper function. In case of an electrical failure, check fuses, connections (for tightness, corrosion, damage), and/or bulbs. If an electrical component needs to be tested for proper function, see Section 5.

Specifications*

(400 - Automatic Transmission)

VALVES AND GUIDES		
Valve Face Diameter	(intake) (exhaust)	30.6 mm (1.20 in.) 27.0 mm (1.06 in.)
Valve/Tappet Clearance (cold engine)	(intake) (exhaust)	0.05-0.10 mm (0.002-0.004 in.) 0.22-0.27 mm (0.009-0.011 in.)
Valve Guide/Stem Clearance	(intake) (exhaust)	0.010-0.037 mm (0.0004-0.0015 in.) 0.030-0.057 mm (0.0012-0.0022 in.)
Valve Guide/Valve Stem Deflection (wobble deflection)	(max)	0.35 mm (0.014 in.)
Valve Guide Inside Diameter		5.000-5.012 mm (0.1969-0.1973 in.)
Valve Stem Outside Diameter	(intake) (exhaust)	4.975-4.990 mm (0.1959-0.1965 in.) 4.955-4.970 mm (0.1951-0.1957 in.)
Valve Stem Runout	(max)	0.05 mm (0.002 in.)
Valve Head Thickness	(min)	0.5 mm (0.02 in.)
Valve Stem End Length	(min)	2.3 mm (0.09 in.)
Valve Face/Seat Width		0.9-1.1 mm (0.035-0.043 in.)
Valve Seat Angle	(intake) (exhaust)	45° 45°
Valve Face Radial Runout	(max)	0.03 mm (0.001 in.)
Valve Spring Free Length	(min)	38.8 mm (1.53 in.)
Valve Spring Tension @ 32.5 mm (1.28 in.)	(outer)	18.6-21.4 kg (41-47 lb)
CAMSHAFT AND CYLINDER HEAD		
Cam Lobe Height (min)	(intake) (exhaust)	32.830 mm (1.293 in.) 32.830 mm (1.293 in.)
Camshaft Journal Oil Clearance	(max)	0.15 mm (0.0059 in.)
Camshaft Journal Holder Inside	(right & center) (left)	22.012-22.025 mm (0.8666-0.8671 in.) 17.512-17.525 mm (0.6894-0.6900 in.)
Camshaft Journal Outside Diameter	(right & center) (left)	21.959-21.980 mm (0.8645-0.8654 in.) 17.466-17.484 mm (0.6876-0.6883 in.)
Camshaft Runout	(max)	0.10 mm (0.004 in.)
Rocker Arm Inside Diameter		12.000-12.018 mm (0.472-0.473 in.)
Rocker Arm Shaft Outside Diameter		11.973-11.984 mm (0.4714-0.4718 in.)
Cylinder Head Distortion	(max)	0.05 mm (0.002 in.)
Cylinder Head Cover Distortion	(max)	0.05 mm (0.002 in.)

CYLINDER, PISTON, AND RINGS	
Piston Skirt/Cylinder Clearance	0.060-0.073 mm (0.0024-0.0029 in.)
Cylinder Bore	82.000-82.015 mm (3.2283-3.2289 in.)
Piston Diameter 15 mm (0.6 in.) from Skirt End	81.930-81.945 mm (3.2256-3.2262 in.)
Piston Ring Free End Gap (min)	(1st Ring) 8.9 mm (0.3504 in.) (2nd Ring) 8.3 mm (0.3268 in.)
Bore x Stroke	82 x 71.2 mm (3.29 x 2.80 in.)
Cylinder Trueness (max)	0.05 mm (0.002 in.)
Piston Ring End Gap - Installed	0.33-0.61 mm (0.013-0.024 in.)
Piston Ring to Groove Clearance (max)	(1st) 0.180 mm (0.0071 in.) (2nd) 0.150 mm (0.0059 in.)
Piston Ring Groove Width	(1st) 1.01-1.03 mm (0.0398-0.0406 in.) (2nd) 1.01-1.03 mm (0.0398-0.0406 in.) (oil) 2.01-2.03 mm (0.0791-0.0799 in.)
Piston Ring Thickness	(1st) 0.97-0.99 mm (0.0381-0.0389 in.) (2nd) 0.97-0.99 mm (0.0381-0.0389 in.)
Piston Pin Bore (max)	20.03 mm (0.789 in.)
Piston Pin Outside Diameter (min)	19.98 mm (0.787 in.)
CRANKSHAFT	
Connecting Rod (small end inside diameter)	(max) 20.04 mm (0.7889 in.)
Connecting Rod (big end side-to-side)	0.10-0.55 mm (0.004-0.022 in.)
Connecting Rod (big end width)	21.95-22.00 mm (0.8642-0.8661 in.)
Connecting Rod (small end deflection)	(max) 3 mm (0.12 in.)
Crankshaft (web-to-web)	59.9-60.1 mm (2.358-2.366 in.)
Crankshaft Runout (max)	0.08 mm (0.003 in.)
Oil Pressure at 60°C (140°F) @ 3000 RPM	(above) 1.1 kg/cm ² (16 psi) (below) 1.5 kg/cm ² (21 psi)
Cooling Fan Thermo-Switch Operating Temperature	(off → on) 120°C (248°F) (on → off) 110°C (230°F)
Engine Oil Thermo-Switch Operating Temperature	(off → on) 160°C (320°F) (on → off) 140°C (284°F)

* Specifications subject to change without notice.

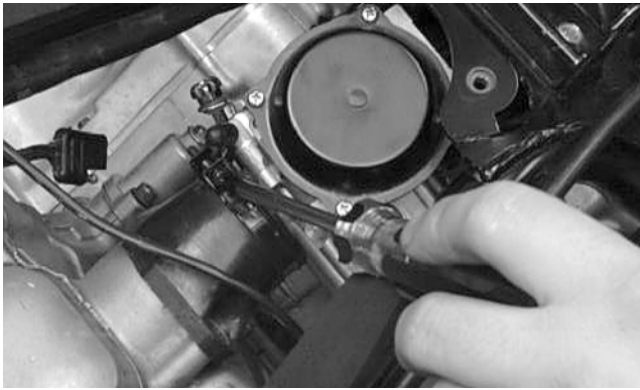

CC120D

■ **NOTE:** Use cable ties or tape to secure the carburetor assembly above the handlebar to keep it from interfering with the removal procedure.

16. Remove the clamps securing the two oil cooler hoses to the engine; then disconnect the hoses.



CC937

■ **NOTE:** After disconnecting the oil cooler hoses, plug them to prevent leakage from the cooler.

17. Disconnect the high tension lead from the spark plug. At the ignition coil, remove the cap screw, nut, and the two wire leads; then remove the coil.

18. Disconnect the battery ground (negative) cable from the crankcase cover; then disconnect the positive cable from the starter motor.

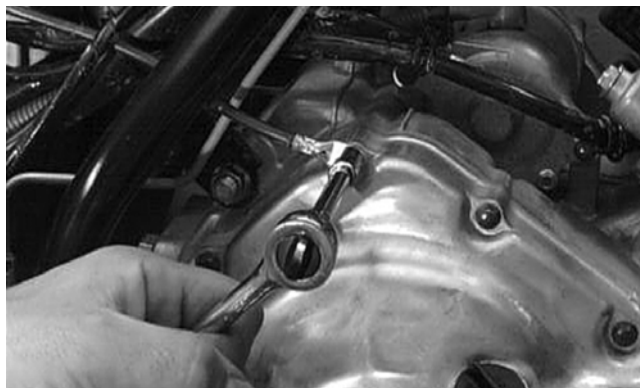

AR600D

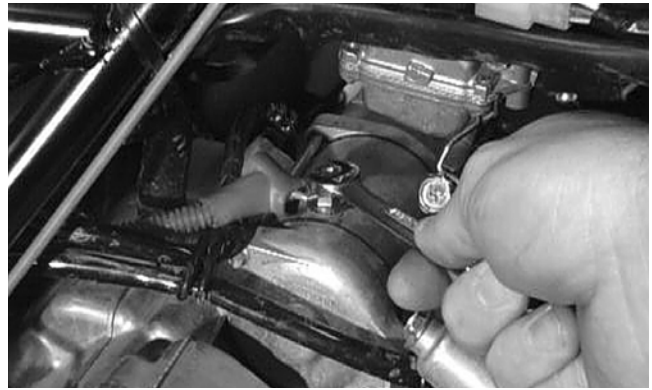

AR604D

19. Disconnect the following electrical components: voltage regulator, CDI, indicator lights, and the two wire leads for the oil temperature sensors.



CF165



CF164A

20. Loosen the clamp on the crankcase breather vent hose; then disconnect the hose and remove it.

21. Remove the engine/transmission mounting fasteners in the following sequence:

A. Lower front: One cap screw, nut, spacer, and washer.

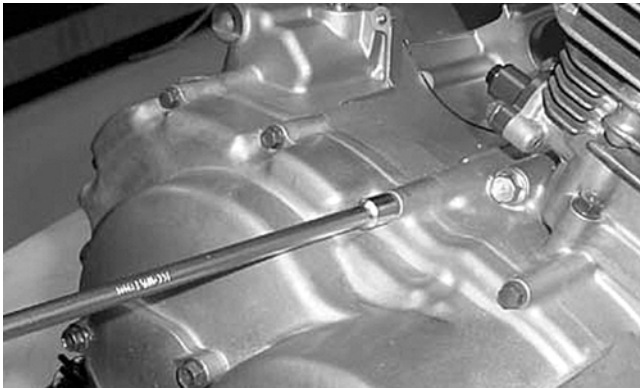

CC968

■ **NOTE:** When removing the right-side cover, account for the release roller guide that it does not fall and cause damage.



CC070D

- B. Primary Clutch Shoe**
- C. Primary Clutch**
- D. Centrifugal Clutch Housing**

■ **NOTE:** Steps 1-2 in the preceding sub-section must precede this procedure.

3. Remove the cap screw securing the clutch release arm and remove the arm; then in a crisscross pattern, remove the four cap screws securing the clutch release roller assembly.

■ **NOTE:** Scribe a reference mark with a marker on the arm and shaft to aid in installing.

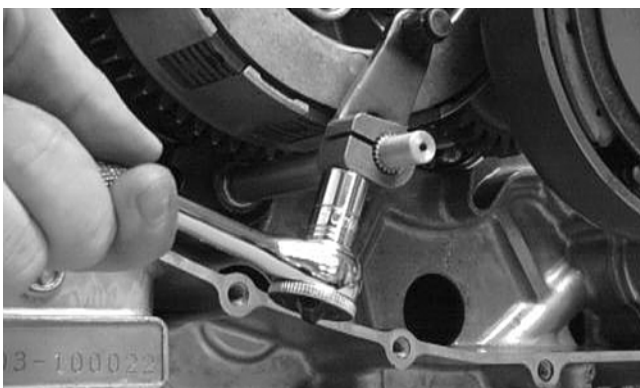

CC073D

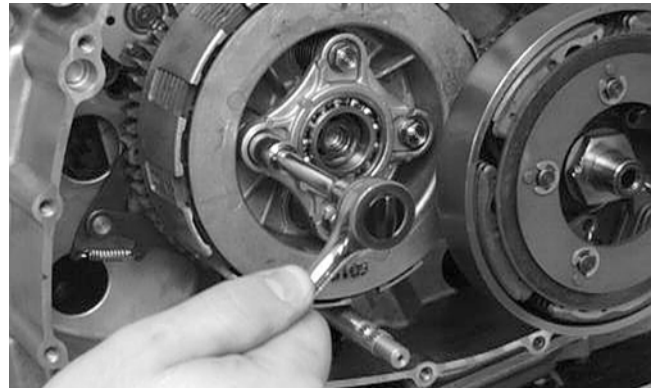

CC074D

4. Remove the release roller assembly. Account for four springs.
5. Remove the centrifugal clutch-shoe nut (left-hand threads) and washer from the driveshaft; then using a primary clutch shoe remover, remove the clutch shoe.

⚠ CAUTION

Care must be taken when removing the nut; it has “left-hand” threads.

3

6. Remove the primary drive one-way clutch from the centrifugal clutch housing. Note the word **OUTSIDE** stamped on the clutch for assembly purposes.



CF043

7. Using the Clutch Sleeve Hub Holder (p/n 0444-007) to hold the clutch sleeve hub, remove the nut and washer.

■ **NOTE:** If the existing rings will not be replaced with new ones, note the location of each ring for proper installation. When installing new rings, install as a complete set only.

Cleaning/Inspecting Piston Rings

1. Take an old piston ring and snap it into two pieces; then grind the end of the old ring to a 45° angle and to a sharp edge.
2. Using the sharpened ring as a tool, clean carbon from the ring-grooves. Be sure to position the ring with its tapered side up.

⚠ CAUTION

Improper cleaning of the ring-grooves by the use of the wrong type of ring-groove cleaner will result in severe damage to the piston.

Measuring Piston-Ring End Gap (Installed)

1. Place each piston ring in the wear portion of the cylinder. Use the piston to position each ring squarely in the cylinder.
2. Using a feeler gauge, measure each piston-ring end gap. Acceptable ring end gap must be within specifications.

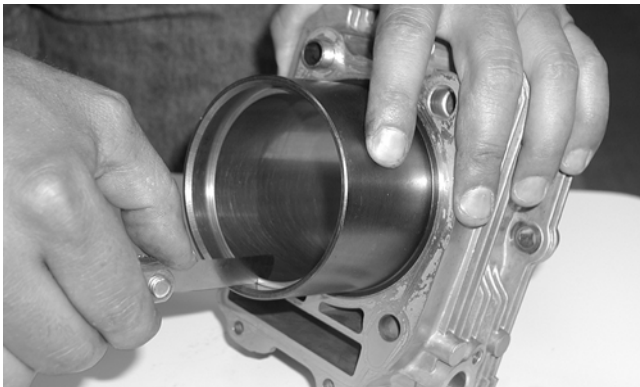

CC995

Measuring Piston Pin (Outside Diameter) and Piston-Pin Bore

1. Measure the piston pin outside diameter at each end and in the center. If measurement is not within specifications, the piston pin must be replaced.

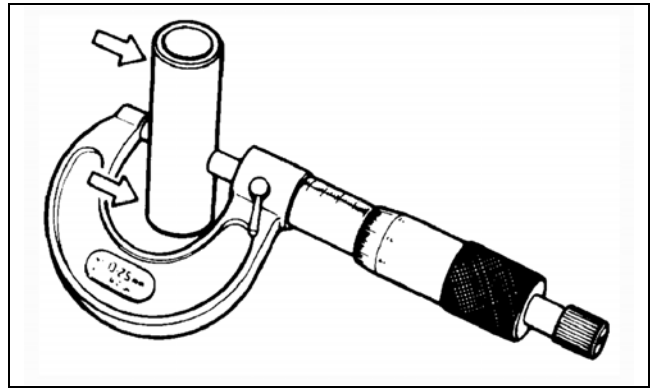

ATV-1070

2. Insert an inside dial indicator into the piston-pin bore. The diameter must not exceed specifications. Take two measurements to ensure accuracy.

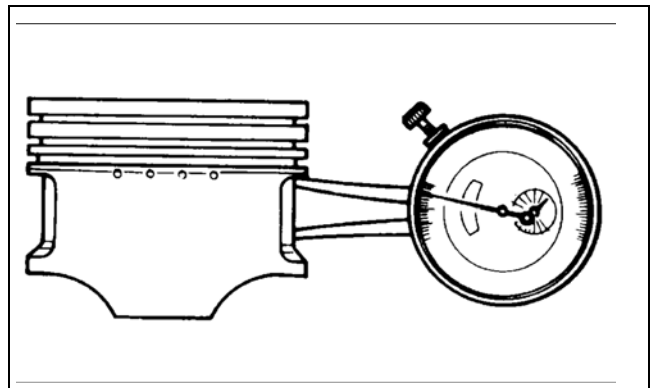

ATV-1069

Measuring Piston Skirt/ Cylinder Clearance

1. Measure the cylinder front to back in six places.

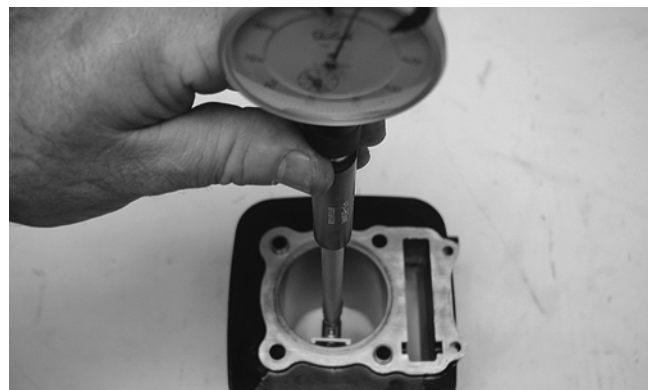

CD325

2. Measure the corresponding piston diameter at a point 15 mm (0.6 in.) above the piston skirt at a right angle to the piston-pin bore. Subtract this measurement from the measurement in step 1. The difference (clearance) must be within specifications.

Assembling Primary Clutch

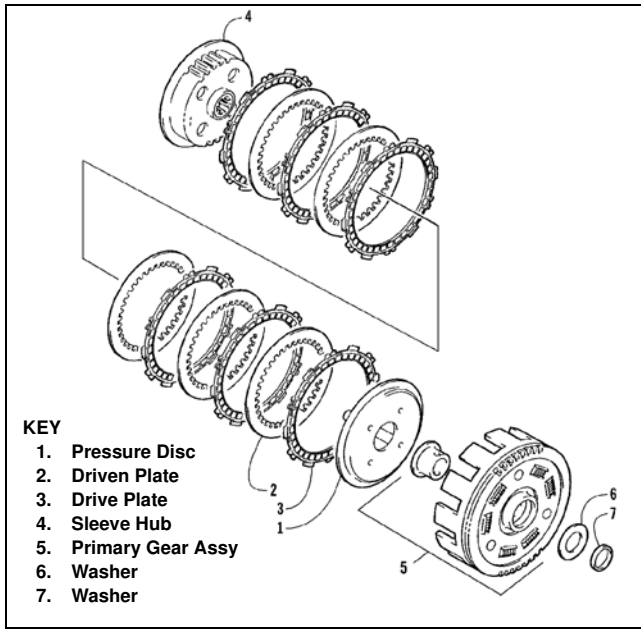

1. Place the clutch hub upside down into the primary gear assembly.

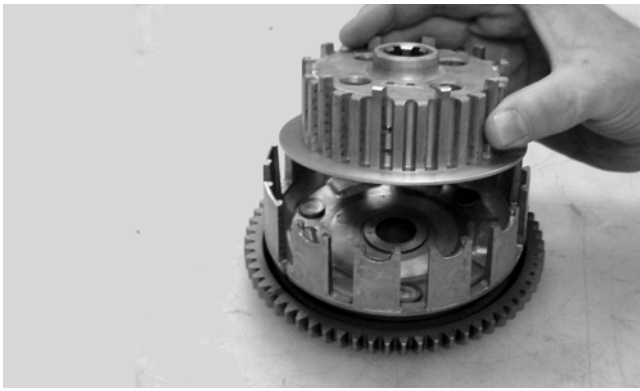

2. Alternately install the drive plates and driven plates onto the hub (starting and ending with a drive plate) making sure the tabs with the notches are all in line with each other.

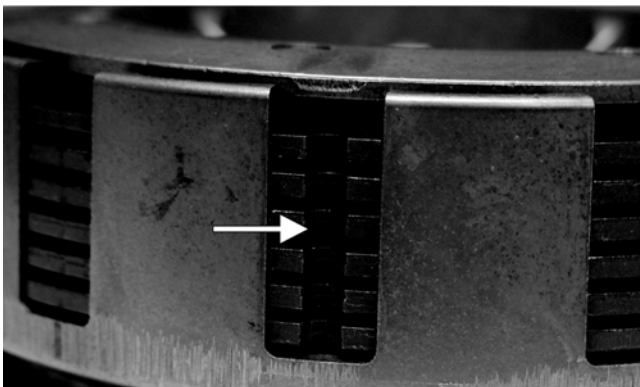

■ **NOTE:** When installing the driven plates for ease of installation, make sure they are placed onto the hub with the rounded side of the plates directed down.

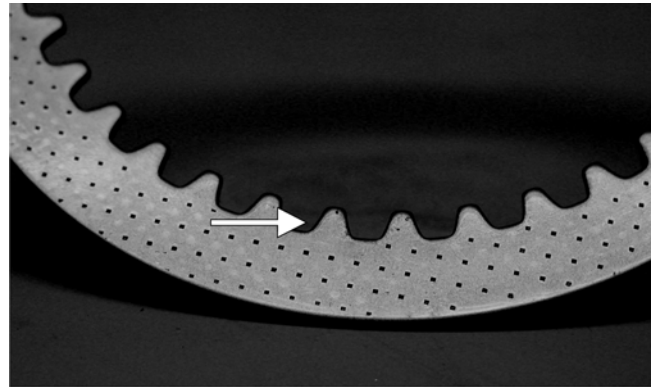

3. Install the pressure plate onto the hub making sure the alignment dots are correctly positioned.

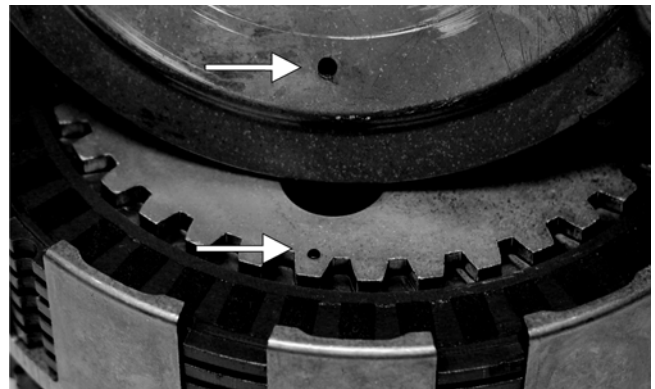

4. Place the primary gear assembly w/clutch hub assembly in one hand, place the other hand on top of the clutch hub assembly, and flip the assembly over; then lift the primary gear assembly off the clutch hub assembly being careful not to disturb the drive plate notched tab orientation.

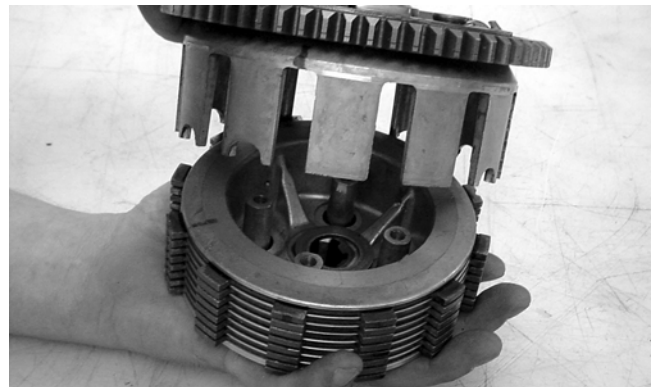

5. Place the primary gear assembly on a clean, flat surface; then install the primary washer into the assembly.

3

10. Slide the reverse driven bushing onto the shaft making sure the oil port in the bushing aligns with the oil port on the shaft.

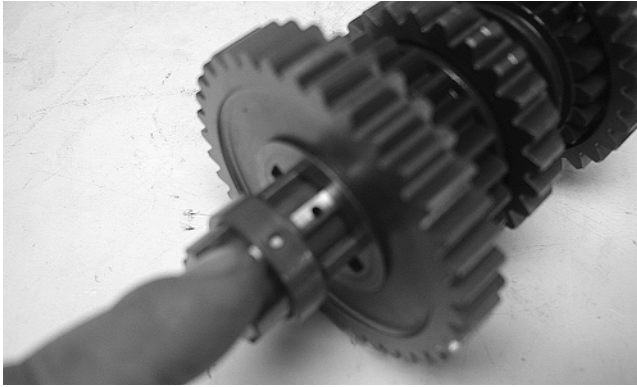

CD337

⚠ CAUTION

Failure to align the oil ports will result in serious engine damage.

11. In order, install the reverse driven gear, washer, circlip, and reverse dog onto the driveshaft.

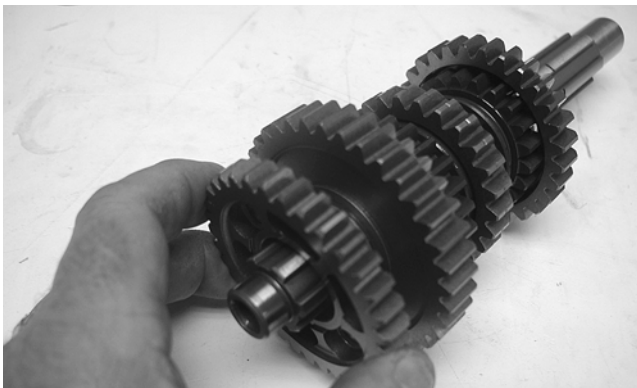

CD336

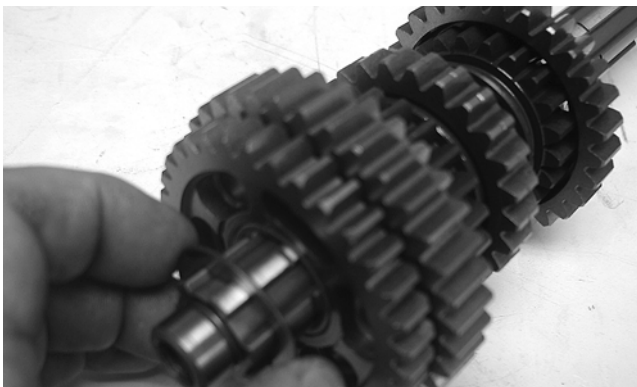

CD335



CD334

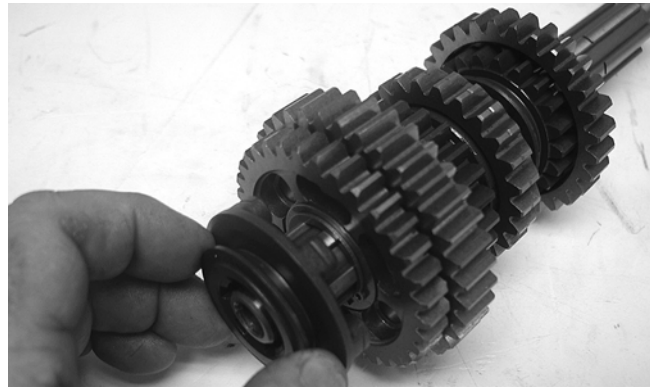

CD331

■ **NOTE:** The driveshaft is now completely assembled for installation.

COUNTERSHAFT

Disassembling

1. Remove the 2nd drive gear from the countershaft.

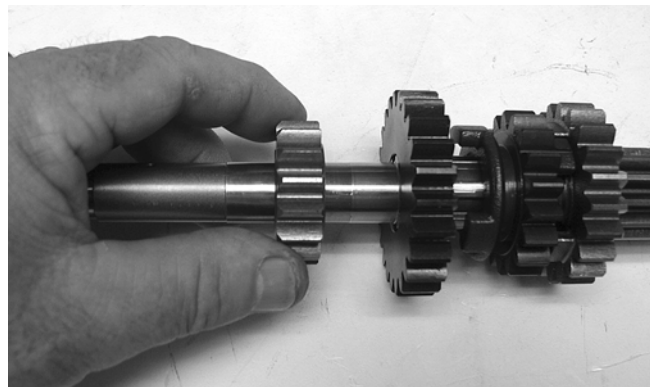

CD395

2. Remove the 5th drive gear from the countershaft.

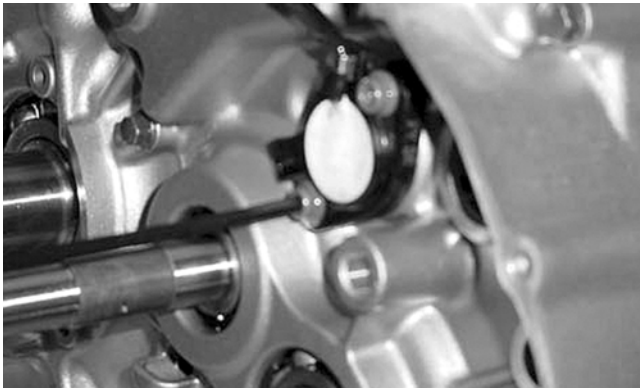

CC964

3. Install the secondary stopper camshaft w/one inner shim and one outer shim.

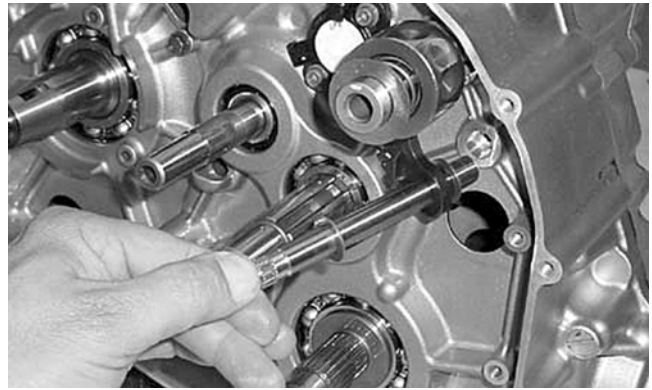

CC960

5. Install the driven gear onto the output shaft.

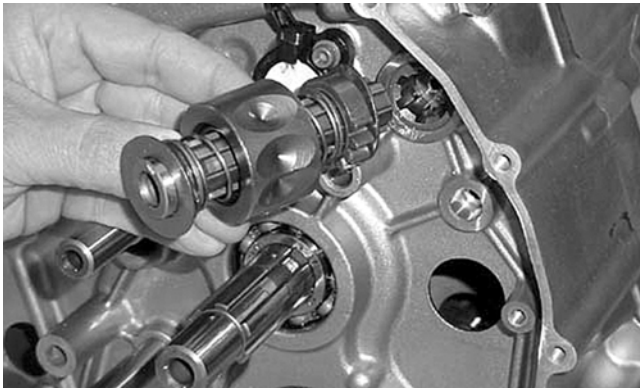

CC962

■ **NOTE:** Care must be taken that the alignment dots on the camshaft plate and the camshaft are properly aligned.

4. Install the gear shift shaft w/one inner washer and one outer washer.

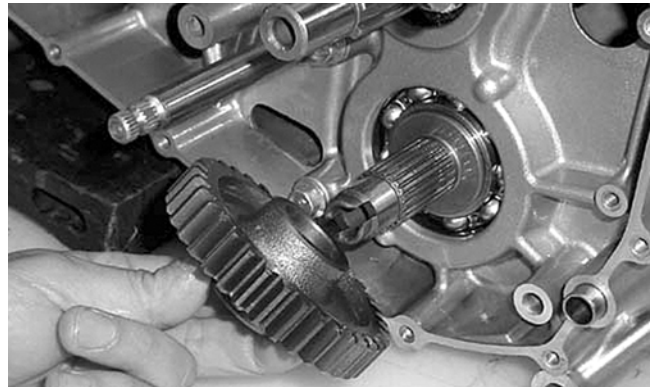

CC959

6. Place the bushing and washer onto the drive-shaft making sure the oil hole of the bushing aligns with the oil hole of the driveshaft.



CD552

7. In turn on the driveshaft, install drive gear #1 and a washer; then secure with the circlip.

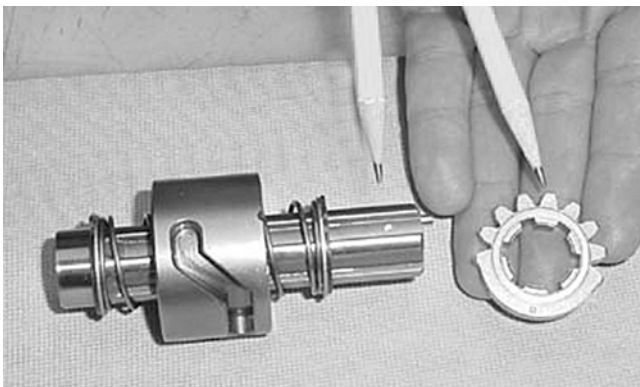

CC963

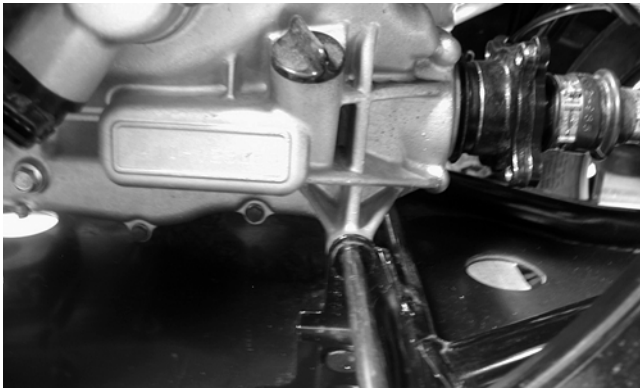

CD809

6. Connect the crankcase breather vent hose and secure with the clamp.

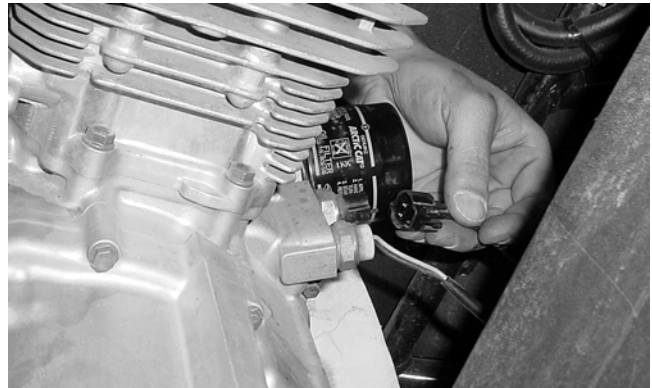

CC939



CC122D

7. Connect the oil cooler hoses to the engine and secure with the clamps.



CC938

9. Connect the positive cable to the starter motor and install the protective boot.



CC937

8. Connect the following electrical components: two wire leads for the oil temperature and oil pressure sensors, indicator lights, CDI, and voltage regulator.

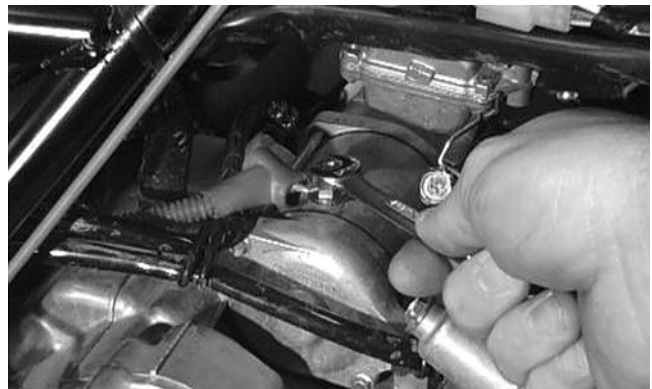

AR604D

10. Connect the battery ground (negative) cable to the crankcase cover.

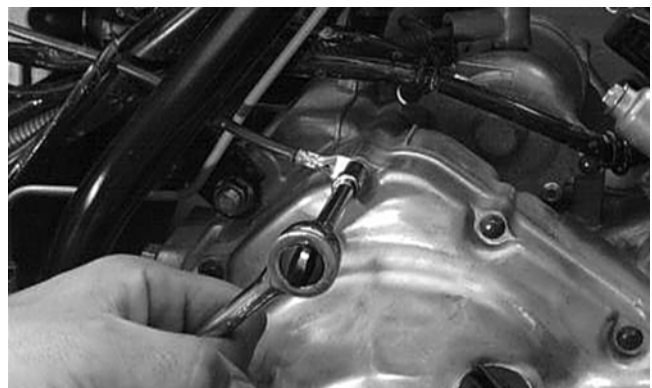

AR600D

Left-Side Components

■ **NOTE:** For efficiency, it is preferable to remove and disassemble only those components which need to be addressed and to service only those components. The technician should use discretion and sound judgment.

 **AT THIS POINT**

To service any one specific component, only limited disassembly of components may be necessary. Note the AT THIS POINT information in each sub-section.

■ **NOTE:** The engine/transmission does not have to be removed from the frame for this procedure.

Removing Left-Side Components

A. Recoil Starter

B. Starter Cup

C. Cover/Stator Assembly

1. Remove the four recoil starter cover cap screws. Remove the recoil starter assembly noting the location of the single washer. Note the condition of the recoil cover gasket. Replace if damaged.

 **AT THIS POINT**

To service the recoil starter, see **Servicing Left-Side Components** sub-section.

2. Remove the flange nut securing the starter cup to the crankshaft; then remove the starter cup. Account for the O-ring inside the cup.



MD1303

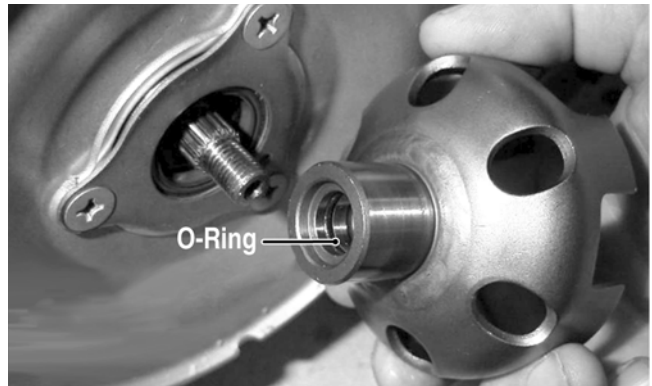

MD1304

3. Lay the engine/transmission on its right side. Remove the 15 left-side cover-to-crankcase mounting cap screws noting the location of the 8 mm cap screw with the washer near the middle of the left-side cover. Keep the different-lengthed 6 mm cap screws in order for installing purposes.

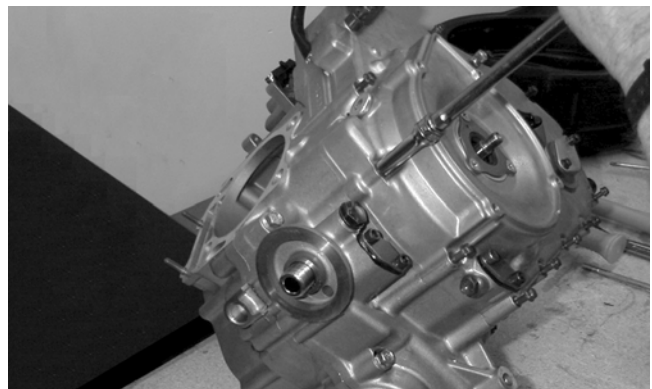

MD1186

4. Using Side Case Puller (p/n 0644-262) and the 6 mm adapter, remove the left-side cover w/stator assembly. Note the condition of the gasket. Replace if necessary. Account for the two alignment pins and the position of the shifter bracket for installing purposes.

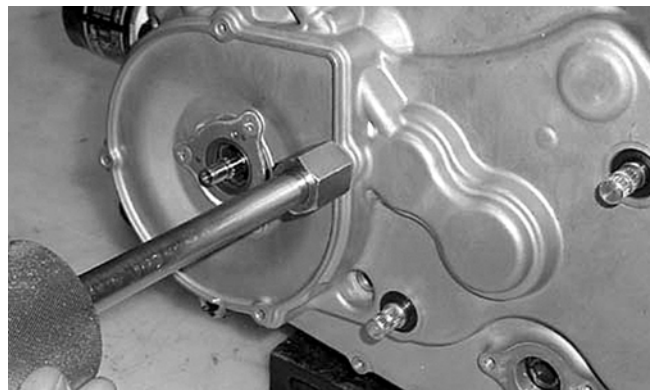

CC946

3

Table of Contents (Servicing Components)

■ **NOTE:** Critical engine/transmission specifications are located at the beginning of this section.

Servicing Top-Side Components	3-93
Valve Assembly	3-93
Piston Assembly	3-96
Cylinder/Cylinder Head Assembly	3-98
Servicing Left-Side Components	3-101
Recoil Starter	3-101
Servicing Right-Side Components	3-104
Inspecting Centrifugal Clutch Shoe	3-104
Inspecting Centrifugal Clutch Housing	3-104
Inspecting Primary One-Way Drive	3-104
Inspecting Oil Pump	3-105
Driven Pulley Assembly	3-105
Servicing Center Crankcase Components	3-109
Secondary Gears	3-109
Crankshaft Assembly	3-110
Countershaft	3-111
Crank Balancer Driven Gear	3-112

Servicing Top-Side Components

■ **NOTE:** Whenever a part is worn excessively, cracked, or damaged in any way, replacement is necessary.

VALVE ASSEMBLY

When servicing valve assembly, inspect valve seats, valve stems, valve faces, and valve stem ends for pits, burn marks, or other signs of abnormal wear.

■ **NOTE:** Whenever a valve is out of tolerance, it must be replaced.

Cleaning/Inspecting Valve Cover

■ **NOTE:** If the valve cover cannot be trued, the cylinder head assembly must be replaced.

1. Wash the valve cover in parts-cleaning solvent.

2. Place the valve cover on the Surface Plate (p/n 0644-016) covered with #400 grit wet-or-dry sandpaper. Using light pressure, move the valve cover in a figure eight motion. Inspect the sealing surface for any indication of high spots. A high spot can be noted by a bright metallic finish. Correct any high spots before assembly by continuing to move the valve cover in a figure eight motion until a uniform bright metallic finish is attained.

⚠ CAUTION

Do not remove an excessive amount of the sealing surface or damage to the camshaft will result. Always check camshaft clearance when resurfacing the valve cover.

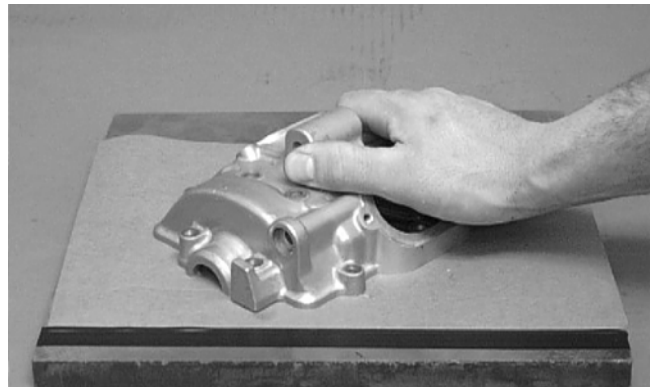

CC130D

⚠ CAUTION

Water or parts-cleaning solvent must be used in conjunction with the wet-or-dry sandpaper or damage to the sealing surface may result.

Removing Valves

■ **NOTE:** Keep all valves and valve components as a set. Note the original location of each valve set for use during installation. Return each valve set to its original location during installation.

1. Using a valve spring compressor, compress the valve springs and remove the valve cotters. Account for an upper spring retainer.

9. Remove the spiral spring from the case by lifting the spring end up and out. Hold the remainder of the spring with thumbs and alternately release each thumb to allow the spring to gradually release from the case.

10. Unwind the rope from the reel and remove the rope.

Cleaning and Inspecting

■ **NOTE:** Whenever a part is worn excessively, cracked, or damaged in any way, replacement is necessary.

1. Clean all components.
2. Inspect the springs and ratchet for wear or damage.
3. Inspect the reel and case for cracks or damage.
4. Inspect the shaft for wear, cracks, or damage.
5. Inspect the rope for breaks or fraying.
6. Inspect the spiral spring for cracks, crystallization, or abnormal bends.
7. Inspect the handle for damage, cracks, or deterioration.

Assembling/Installing

1. If removed, insert the spiral spring into the case with the outer end of the spring around the mounting lug in the case; then wind it in a counterclockwise direction until the complete spring is installed.

■ **NOTE:** The spiral spring must seat evenly in the recoil case.



B606D

2. Insert the rope through the hole in the reel and tie a knot in the end; then wrap the rope counterclockwise around the reel leaving approximately 50 cm (20 in.) of rope free of the reel.

3. Apply low-temperature grease to the spring and hub.

4. Thread the end of the rope through the guide hole of the case; then thread the rope through the handle and secure it with a double knot. Install the protective cover into the handle.

5. Align the inner hook of the spiral spring with the notch in the reel.

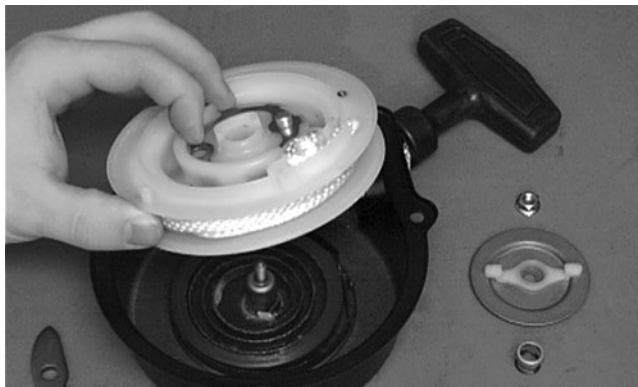

B605D

6. Install the ratchet onto its pin making sure the end is properly installed on the reel.



B604D

7. Install the shaft, spring, and the spring cover.



B603D

8. Install the friction plate with the ratchet guide fitting into the ratchet.



MD1199



MD1334

■ **NOTE:** If heating the bearing is not possible, the crankshaft can be installed using a crankshaft installer.

4. Rotate the crankshaft so the counterweight is toward the rear of the engine. Install the counterbalance shaft.

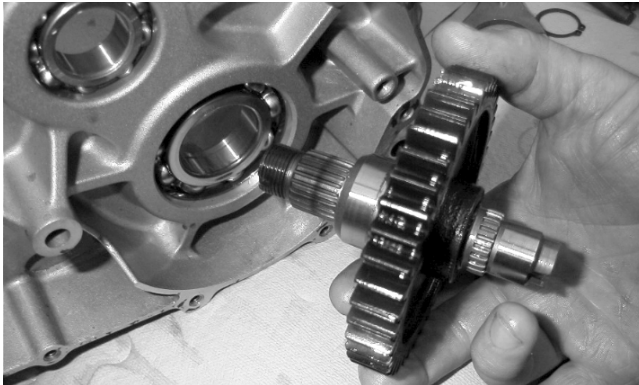

MD1079

2. Apply red Loctite #271 to the threads of the output shaft. Install and tighten the nut specifications. Using a punch, peen the nut.

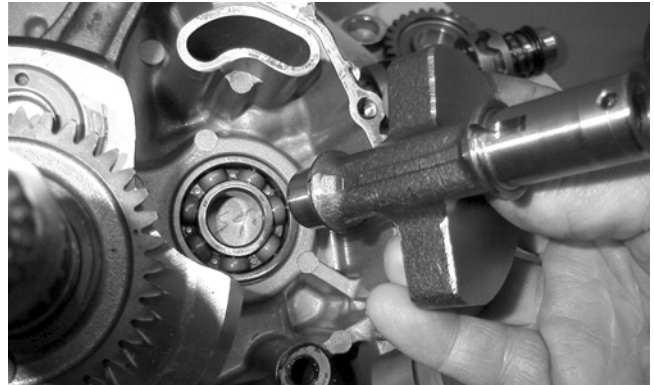

MD1024

5. Keeping the counterbalance gear timing mark aligned with the one on the crankshaft gear, install the key and the counterbalance gear.



MD1333

3. Apply a liberal amount of oil to the crankshaft bearing. Using a propane torch, heat the bearing until the oil begins to smoke; then slide the crankshaft assembly into place.



CC166D

6. Keeping the two holes facing up, install the shift cam and inner and outer washers.

3

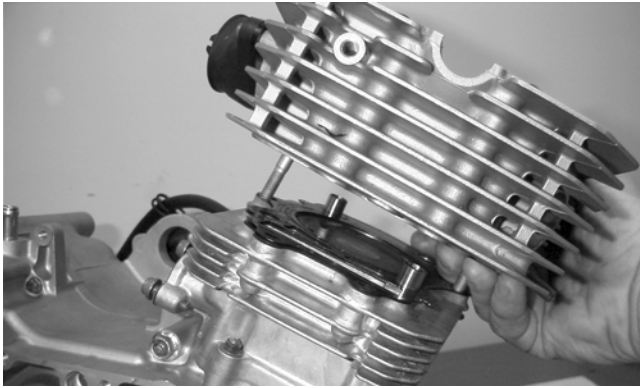

MD1163

7. Install the four cylinder head cap screws with washers. Note that the two cap screws on the right side of the cylinder head nearest the cam sprocket are longer than the two cap screws on the left (spark plug) side. Tighten only until snug.

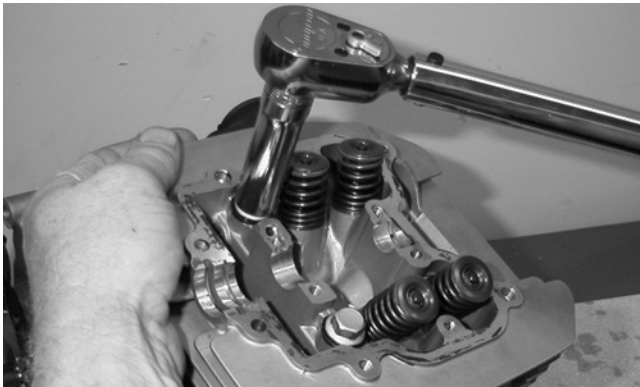

MD1270

8. Install the two lower nuts securing the cylinder head to the cylinder, one in front and one in rear.

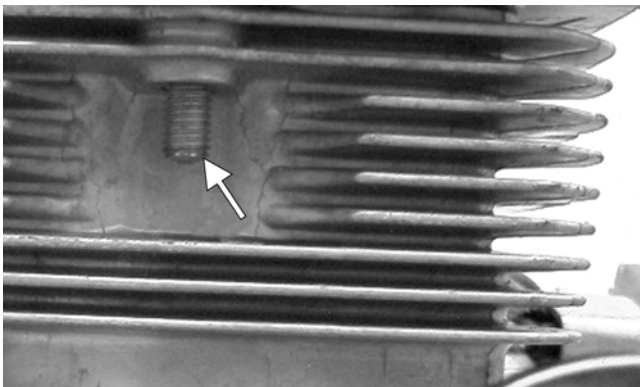

MD1192

9. In a crisscross pattern, tighten the four cylinder head cap screws (from step 7) to specifications. Tighten the two lower cylinder head nuts (from step 8) to specifications and the cylinder-to-crankcase nuts (from step 4) to specifications.
10. With the timing inspection plug removed and the cam chain held tight, rotate the crankshaft until the piston is at top-dead-center.

11. While holding the cam chain sprocket to the side, install the rear cam chain tensioner guide into the cylinder head. Install the pivot cap screw and washer.

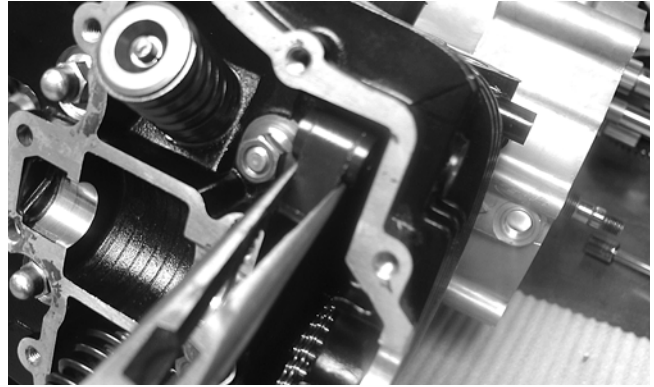

CD383

12. With the alignment pin installed in the camshaft and the cam lobes directed down (toward the piston), place the camshaft in position and verify that the timing mark on the magneto is visible through the inspection plug and that the timing marks on the camshaft sprocket are parallel with the valve cover mating surface.

3

■ **NOTE:** When the camshaft assembly is seated, make sure the alignment pin in the camshaft aligns with the smallest hole in the sprocket.

13. With the alignment pin installed in the camshaft, loosely place the cam sprocket (with the recessed side facing the camshaft lobes) onto the camshaft and place it into position with the cam chain over the sprocket.

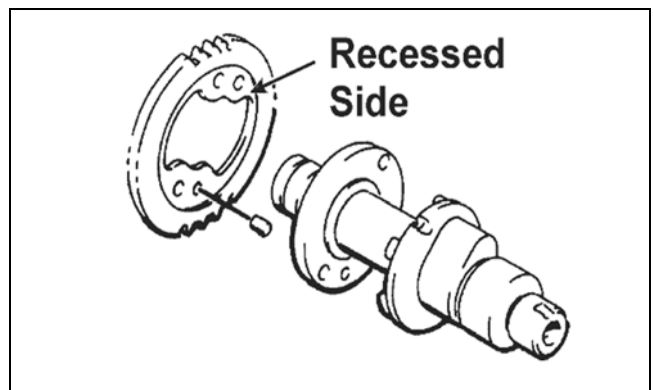

MD1359

14. Place the C-ring into position in its groove in the cylinder head.

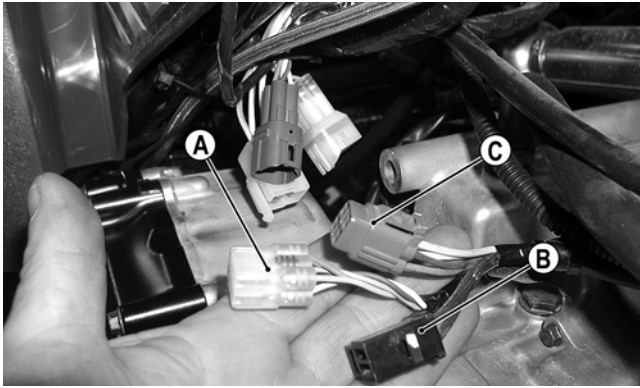

CD797A

22. Disconnect the temperature sensor lead from the wiring harness.

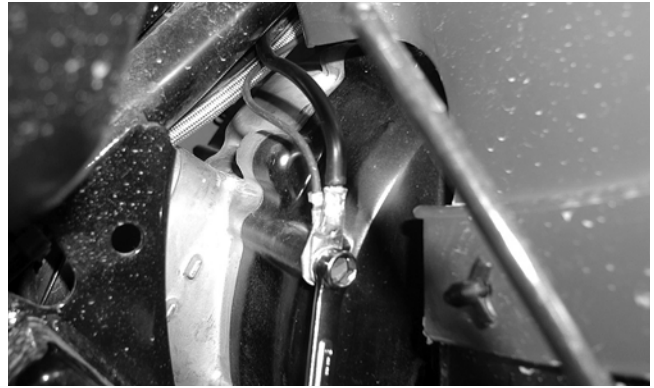

CD810

25. Remove the two engine mounting through-bolts. Account for a washer and a spacer on the bolts.



CD788

23. Remove the spark plug wire from the spark plug; then remove the coil from the frame.

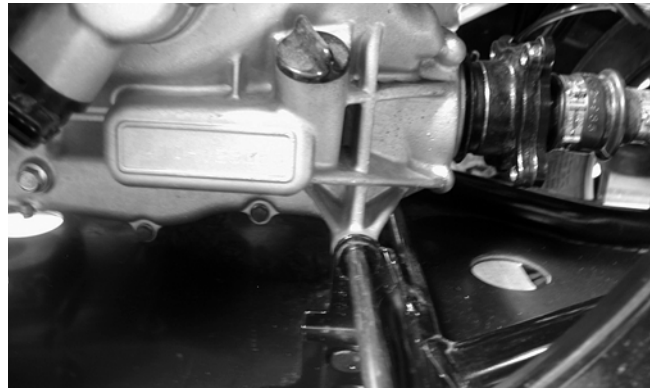

CD809

26. Raise the rear of the engine enough to allow the rear output flange to clear the output flange joint. Block the engine up in this position.



CD814

24. Remove the cap screw securing the engine ground wire to the engine.



CD811

27. Remove the first small boot clamp; then remove the output flange and driveshaft from the rear drive coupler.

3

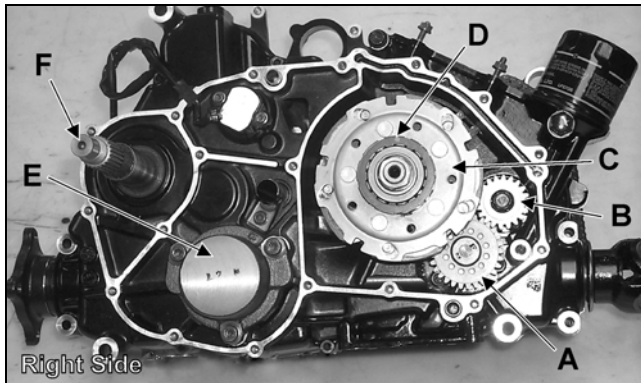

Right Side

- | | |
|--------------------------------|--|
| KEY | D. One-Way Clutch
(Green Dot MUST Show) |
| A. Oil Pump Driven Gear | E. Final Drive Carrier Bearing Housing |
| B. Oil Pump Drive Gear | F. Input Shaft |
| C. Clutch Shoe Assembly | |

CC829B

8. Remove the one-way clutch (D) from the clutch housing. Note the location of the green alignment dot (or the word **OUTSIDE**) for installing purposes.
9. Using a hydraulic press, remove the clutch housing assembly from the clutch cover. Account for the left fixed drive spacer and an O-ring inside the fixed drive spacer.



CF085



CC596

■ **NOTE:** Account for and inspect the clutch housing seal.

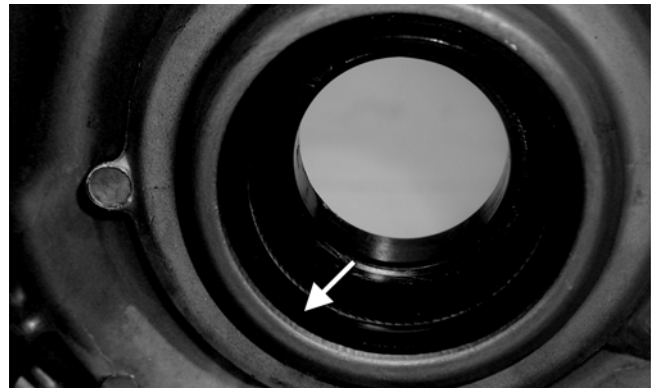

CF088A

10. Remove the two Allen-head screws securing the shift indicator sensor; then remove the sensor. Account for two neutral contact pins and two springs.

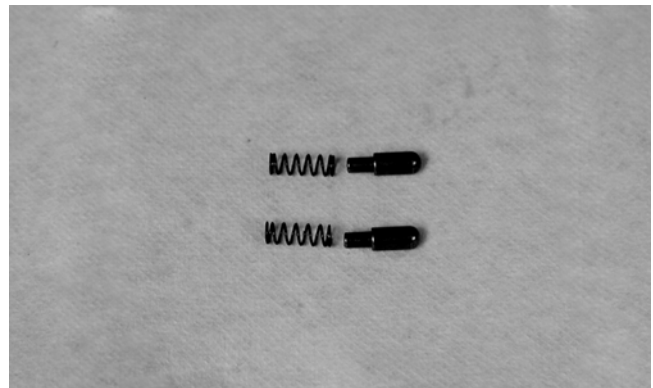

CD997

11. Remove the nut (left-hand threads) securing the clutch shoe assembly (C). Account for a washer.



FI279A

■ **NOTE:** The washer is also directional. The flat side of the washer must face toward the centrifugal clutch assembly when installing.

- Place the cylinder head on the surface plate covered with #400 grit wet-or-dry sandpaper. Using light pressure, move the cylinder head in a figure eight motion. Inspect the sealing surface for any indication of high spots. A high spot can be noted by a bright metallic finish. Correct any high spots before assembly by continuing to move the cylinder head in a figure eight motion until a uniform bright metallic finish is attained.

⚠ CAUTION

Water or parts-cleaning solvent must be used in conjunction with the wet-or-dry sandpaper or damage to the sealing surface may result.

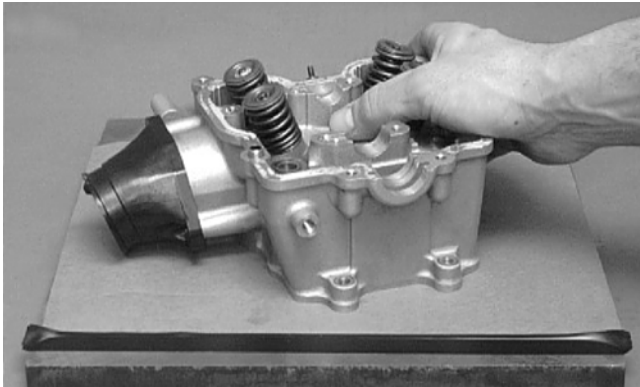

CC128D

Measuring Cylinder Head Distortion

- Remove any carbon buildup in the combustion chamber.
- Lay a straightedge across the cylinder head; then using a feeler gauge, check the distortion factor between the head and the straightedge.
- Maximum distortion must not exceed specifications.



CC141D

Cleaning/Inspecting Cylinder

- Wash the cylinder in parts-cleaning solvent.

- Inspect the cylinder for pitting, scoring, scuffing, warpage, and corrosion. If marks are found, repair the surface using a cylinder hone (see Honing Cylinder in this sub-section).

- Place the cylinder on the surface plate covered with #400 grit wet-or-dry sandpaper. Using light pressure, move the cylinder in a figure eight motion. Inspect the sealing surface for any indication of high spots. A high spot can be noted by a bright metallic finish. Correct any high spots before assembly by continuing to move the cylinder in a figure eight motion until a uniform bright metallic finish is attained.

⚠ CAUTION

Water or parts-cleaning solvent must be used in conjunction with the wet-or-dry sandpaper or damage to the sealing surface may result.

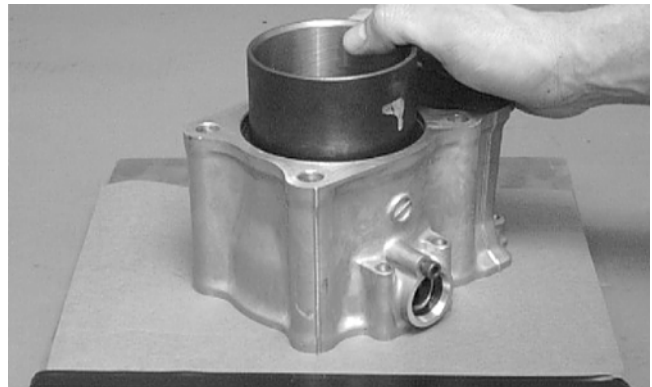

CC129D

3

Inspecting Cam Chain Guide

- Inspect cam chain guide for cuts, tears, breaks, or chips.
- If the chain guide is damaged, it must be replaced.

Honing Cylinder

- Using a slide gauge and a dial indicator or a snap gauge, measure the cylinder bore diameter in three locations from top to bottom and again from top to bottom at 90° from the first measurements for a total of six measurements. The trueness (out-of-roundness) is the difference between the highest and lowest reading. Maximum trueness (out-of-roundness) must not exceed specifications.



CD052

8. Compress the spring until the spring holder nears the threads on the fixed face hub; then using the handle, wind the spring holder counterclockwise to align the flats of the spring holder and hub.



CD052A

9. Continue compressing the spring while guiding the spring holder onto the hub. When a slight resistance is felt, stop turning the wing nut.
10. Install the nut (threads coated with red Loctite #271); then tighten the nut to specification using the spanner and a torque wrench.



CD066

11. Remove the wing nut, washer, and holding handle; then remove the driven pulley from the pulley compressor.

Servicing Center Crankcase Components

■ **NOTE:** Whenever a part is worn excessively, cracked, damaged in any way, or out of tolerance, replacement is necessary.

SECONDARY GEARS

■ **NOTE:** When checking and correcting secondary gear backlash and tooth contact, the universal joint must be secured to the front shaft or false measurements will occur.

Checking Backlash

■ **NOTE:** The rear shaft and bevel gear must be removed for this procedure. Also, always start with the original shims on the rear shaft.

3

1. Place the left-side crankcase cover onto the left-side crankcase half to prevent runout of the secondary transmission output shaft.
2. Install the secondary driven output shaft assembly onto the crankcase.
3. Mount the dial indicator so the tip is contacting a tooth on the secondary driven bevel gear.
4. While rocking the driven bevel gear back and forth, note the maximum backlash reading on the gauge.
5. Acceptable backlash range is 0.05-0.33 mm (0.002-0.013 in.).

Correcting Backlash

■ **NOTE:** If backlash measurement is within the acceptable range, no correction is necessary.

1. If backlash measurement is less than specified, remove an existing shim, measure it, and install a new thinner shim.
2. If backlash measurement is more than specified, remove an existing shim, measure it, and install a thicker shim.

■ **NOTE:** Continue to remove, measure, and install until backlash measurement is within tolerance. Note the following chart.

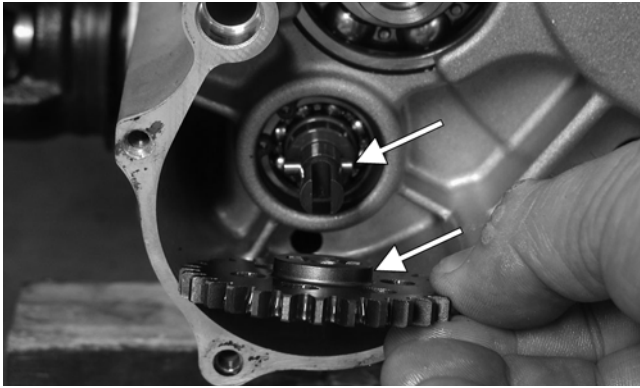

CD952A



CD944

■ **NOTE:** The sharp side of the snap ring should be facing outward.

■ **NOTE:** Once the gears are secured, remove the oil passage plug from the crankcase.

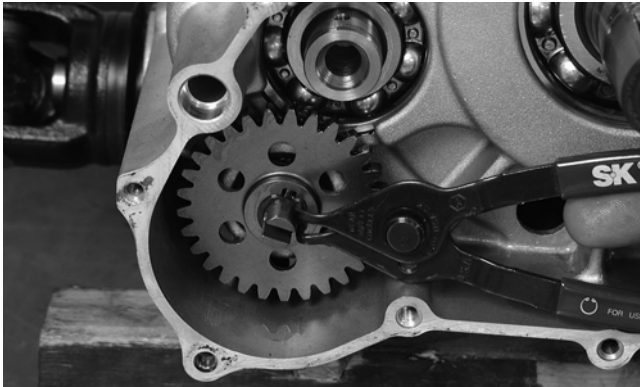

CD949

■ **NOTE:** The sharp side of the snap ring should be facing outward.

2. Install the water pump drive gear drive pin and the drive gear (with the flat side of the gear facing outward as noted in removing); then secure with the snap ring.

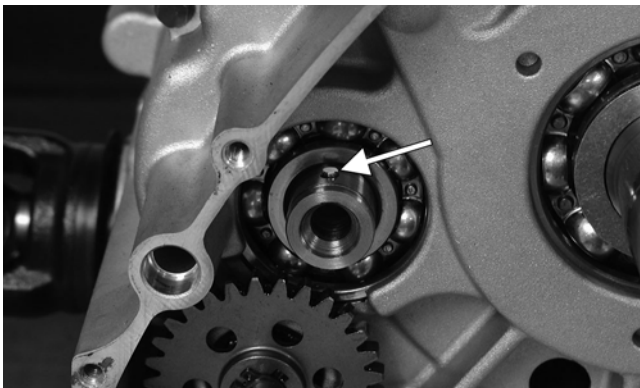

CD946A



CD139



CD145

4. In order on the crankshaft, install a washer, ring gear, key, and the magneto rotor. Secure with the nut (threads coated with red Loctite #271). Tighten to specifications.

3. Install the two starter gear shafts; then install the two starter gears (with the beveled side of the intermediate gear facing inward as noted in removing).

3

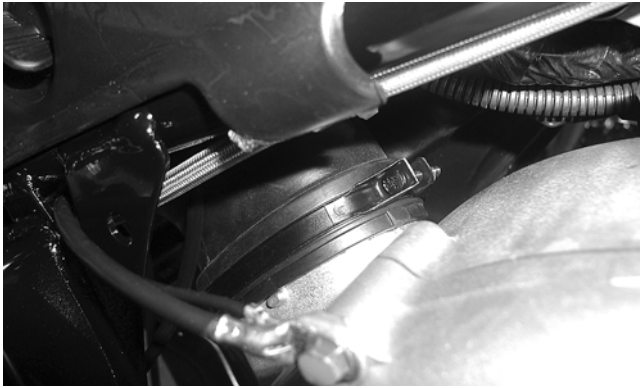

CD515



CD793

8. Secure the engine ground wire to the engine with a cap screw. Tighten to specifications.



CD810

9. Connect the gear position indicator connector (A), stator connector (B), and the CDI connector (C) to the main wiring harness.

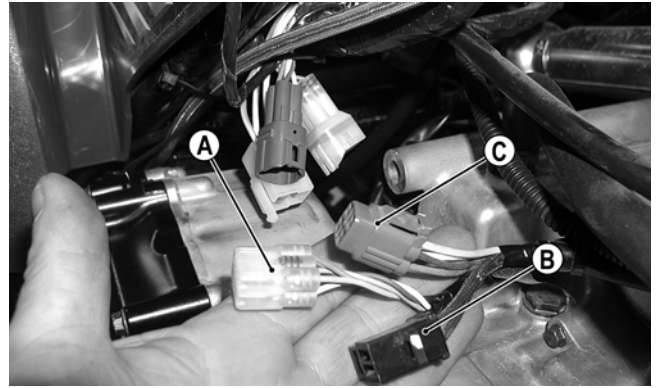

CD797A

10. Connect the temperature sensor wire to the main wiring harness.
11. Secure the wires to the frame with nylon ties.
12. Connect the speed sensor connector to the housing.
13. Secure the positive cable to the starter motor.
14. Secure all wiring to the frame and upper engine bracket with cable ties.
15. Secure the two coolant/oil hoses to the engine.
16. Secure the crankcase vent hose to the air cleaner housing; then secure the inlet boot and carburetor to the air cleaner housing.

3



CD787



CD785

CLICK HERE TO **DOWNLOAD** THE COMPLETE MANUAL

- Thank you very much for reading the preview of the manual.
- You can download the complete manual from: www.heydownloads.com by clicking the link below



- Please note: If there is no response to **CLICKING** the link, please download this PDF first and then click on it.

CLICK HERE TO **DOWNLOAD** THE COMPLETE MANUAL

- B. Remove each ring by working it toward the dome of the piston while rotating it out of the groove.

👉 AT THIS POINT

To service piston, see Servicing Top-Side Components sub-section.

👉 AT THIS POINT

To service center crankcase components only, proceed to Removing Left-Side Components.

Left-Side Components

■ **NOTE:** For efficiency, it is preferable to remove and disassemble only those components which need to be addressed and to service only those components. The technician should use discretion and sound judgment.

👉 AT THIS POINT

To service any one specific component, only limited disassembly of components may be necessary. Note the AT THIS POINT information in each sub-section.

■ **NOTE:** The engine/transmission does not have to be removed from the frame for this procedure.

Removing Left-Side Components

- A. Recoil Starter**
- B. Hi/Low Shifter Assembly**
- C. Speed Sensor Housing**
- D. Cover**

1. Remove the cap screws securing the recoil starter assembly to the left-side cover; then remove the recoil starter.

👉 AT THIS POINT

To service the recoil starter, see Servicing Left-Side Components sub-section.

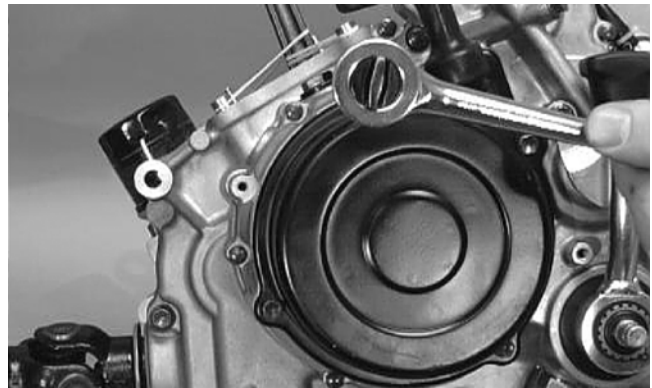

CC039D

2. Remove the flange nut securing the starter cup to the crankshaft; then remove the starter cup. Account for the O-ring inside the cup.

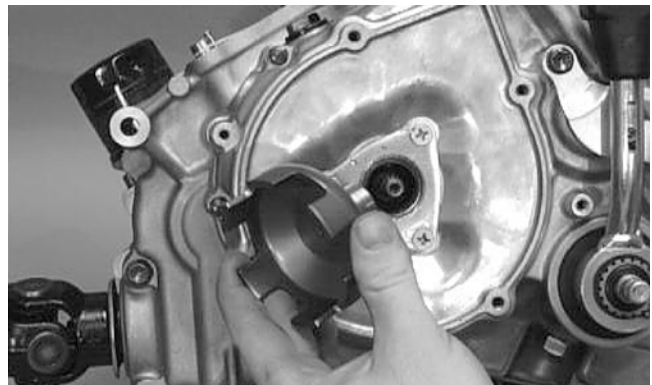

CC041D

3. Put the shift lever into the hi-range position and remove the circlip from the hi/low range shift shaft; then remove the shift lever.

■ **NOTE:** It will be necessary to lift slightly on the shift lever to remove it from the shaft and plate.

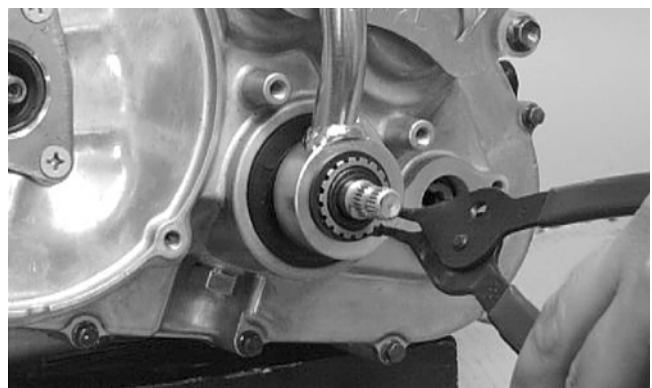

CC044D

3

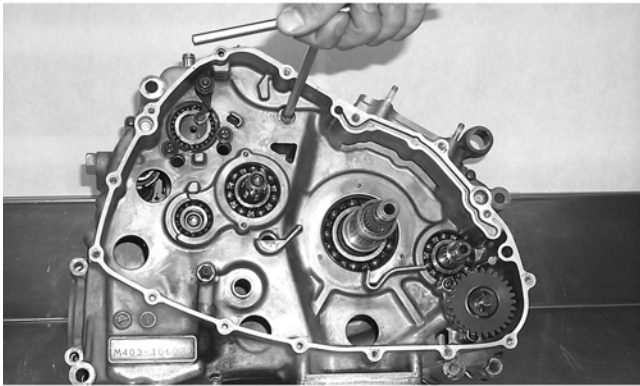

CC530D

2. Remove the seven left-side 6 mm cap screws securing the crankcase halves. Note the location of the wiring form. Note the location of the different-lengthed cap screws.

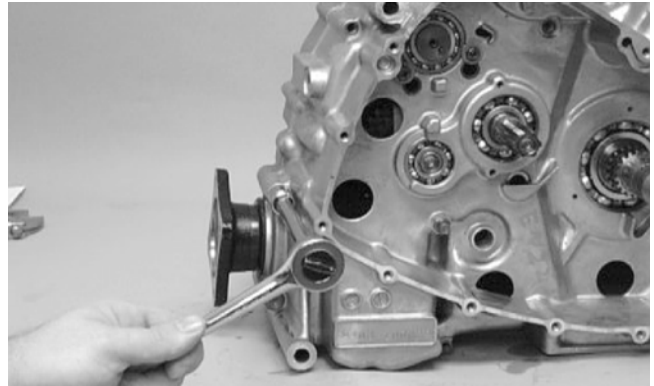

CC098D

5. Using the Crankcase Separator/Crankshaft Remover (p/n 0444-009) and tapping lightly with a rubber mallet, separate the crankcase halves. Account for two alignment pins, an O-ring, and a washer.

■ **NOTE:** To keep the shaft/gear assemblies intact for identification, tap the shafts toward the left-side crankcase half when separating the halves.

3

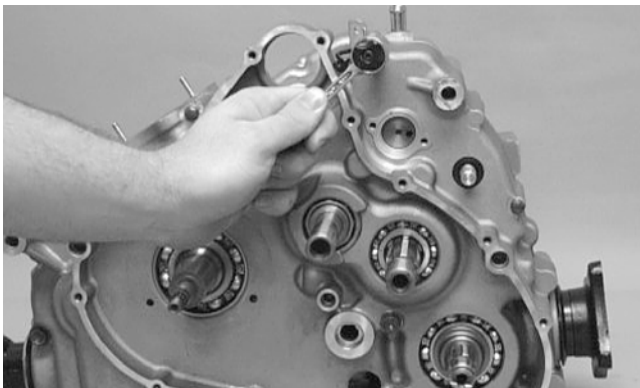

CC096D

3. Remove the three left-side 8 mm cap screws (two from inside the case) securing the crankcase halves. Note the location of the different-lengthed cap screws.



CC099D

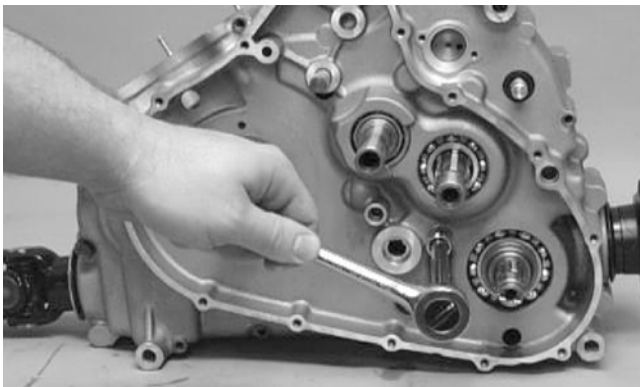

CC097D

4. Remove the three right-side 8 mm cap screws securing the crankcase halves.

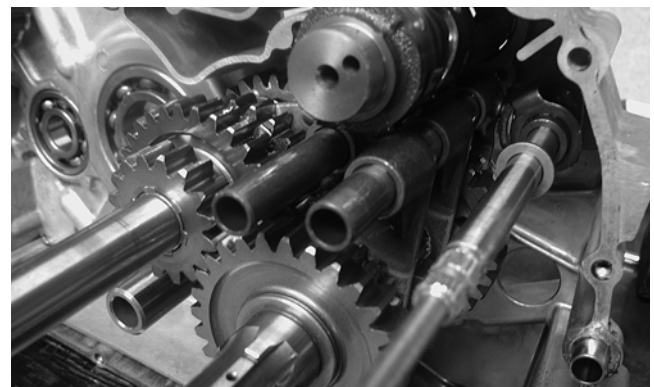

CD227

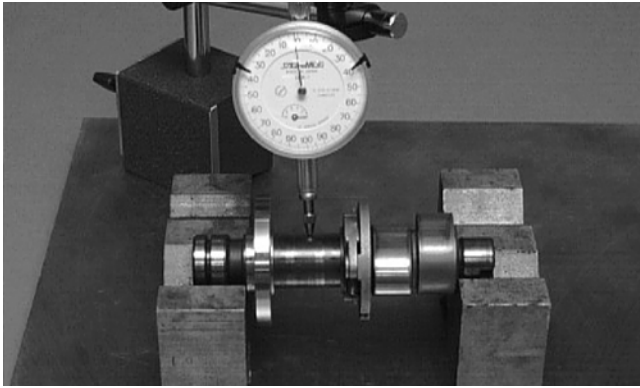

CC283D

2. Rotate the camshaft and note runout; maximum tolerance must not exceed specifications.

Measuring Camshaft Lobe Height

1. Using a calipers, measure each cam lobe height.

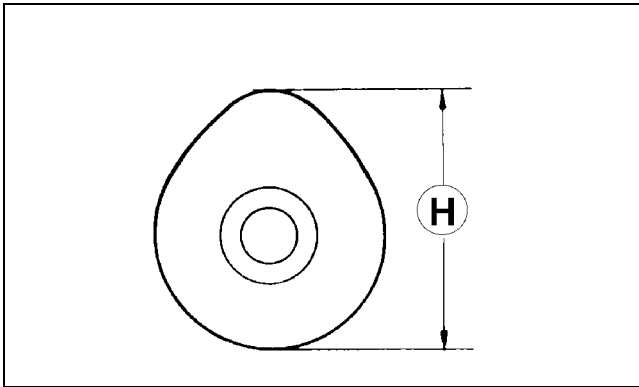

ATV1013A

2. The lobe heights must not exceed minimum specifications.

Inspecting Camshaft Bearing Journal

1. Inspect the bearing journal for scoring, seizure marks, or pitting.
2. If excessive scoring, seizure marks, or pitting is found, the cylinder head assembly must be replaced.

Measuring Camshaft to Cylinder Head Clearance

1. Remove the adjuster screws and jam nuts.

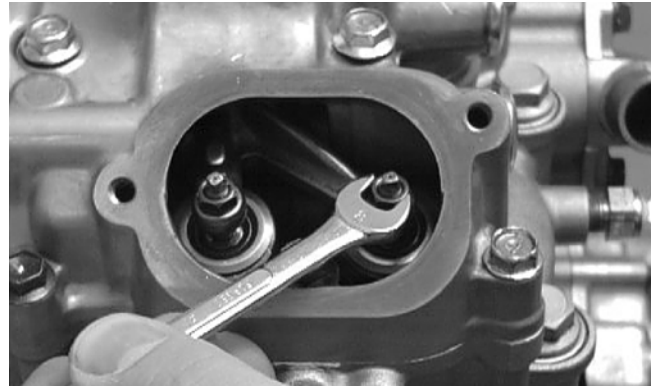

CC005D

2. Place a strip of plasti-gauge in each of the camshaft lands in the cylinder head.
3. Place the valve cover on the cylinder head and secure with the valve cover cap screws. Tighten securely.

■ **NOTE:** Do not rotate the camshaft when measuring clearance.

4. Remove the cap screws securing the valve cover to the cylinder; then remove the valve cover and camshaft.

3

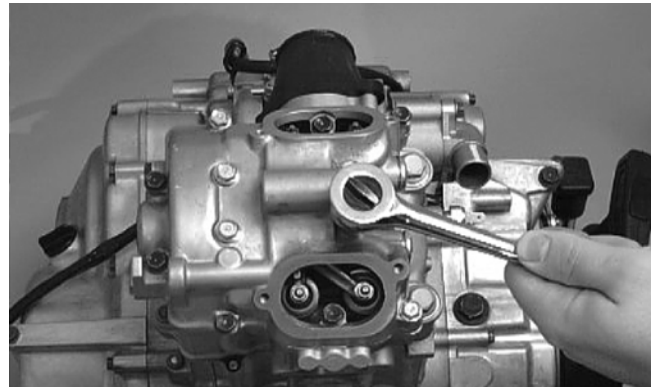

CC003D

5. Match the width of the plasti-gauge with the chart found on the plasti-gauge packaging to determine camshaft to cylinder head and valve cover clearance.

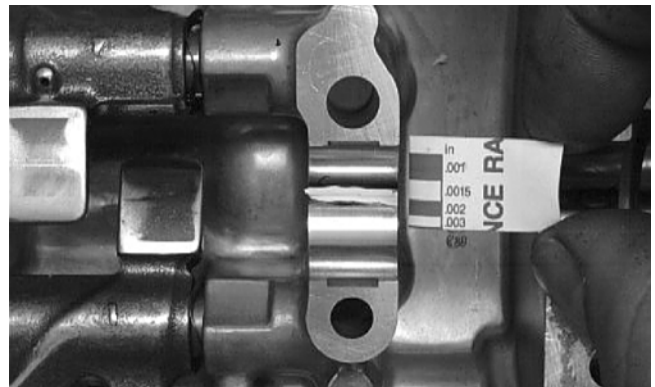

CC145D

6. If clearance is excessive, measure the journals of the camshaft.

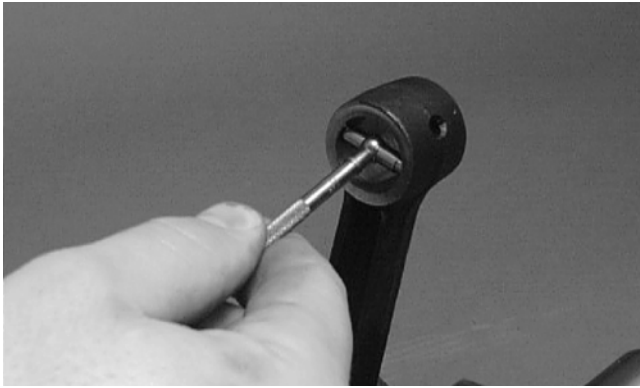

CC290D

2. Maximum diameter must not exceed specifications.

Measuring Connecting Rod (Small End Deflection)

1. Place the crankshaft on a set of V blocks and mount a dial indicator and base on the surface plate. Position the indicator contact point against the center of the connecting rod small end journal.
2. Zero the indicator and push the small end of the connecting rod away from the dial indicator.
3. Maximum deflection must not exceed specifications.

Measuring Connecting Rod (Big End Side-to-Side)

1. Push the lower end of the connecting rod to one side of the crankshaft journal.
2. Using a feeler gauge, measure the gap between the connecting rod and crankshaft journal.



CC289D

3. Acceptable gap range must be within specifications.

Measuring Connecting Rod (Big End Width)

1. Using a calipers, measure the width of the connecting rod at the big-end bearing.
2. Acceptable width range must be within specifications.

Measuring Crankshaft (Runout)

1. Place the crankshaft on a set of V blocks.
2. Mount a dial indicator and base on the surface plate. Position the indicator contact at point 1 of the crankshaft.

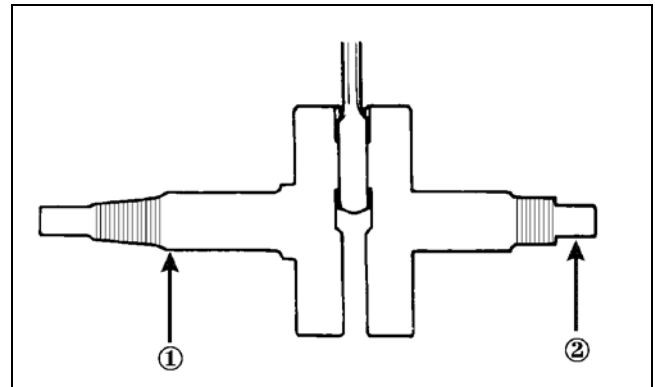

ATV-1074

3. Zero the indicator and rotate the crankshaft slowly.

CAUTION

Care should be taken to support the connecting rod when rotating the crankshaft.

4. Maximum runout must not exceed specifications.

■ **NOTE:** Proceed to check runout on the other end of the crankshaft by positioning the indicator contact at point 2 and following steps 2-4.

Measuring Crankshaft (Web-to-Web)

1. Using a calipers, measure the distance from the outside edge of one web to the outside edge of the other web.

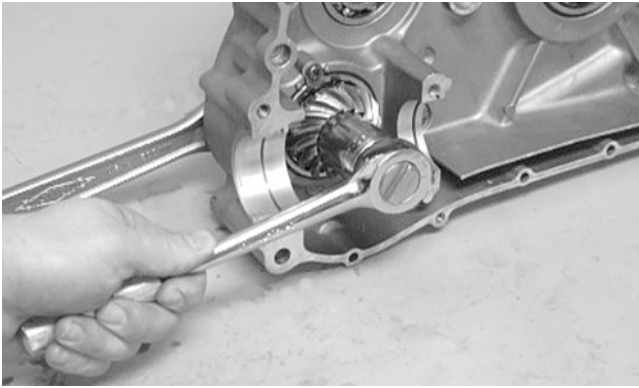

CC116D

2. Apply a liberal amount of engine oil to the crankshaft bearing. Using a propane torch, heat the bearing until the oil begins to smoke; then slide the crankshaft assembly into place.

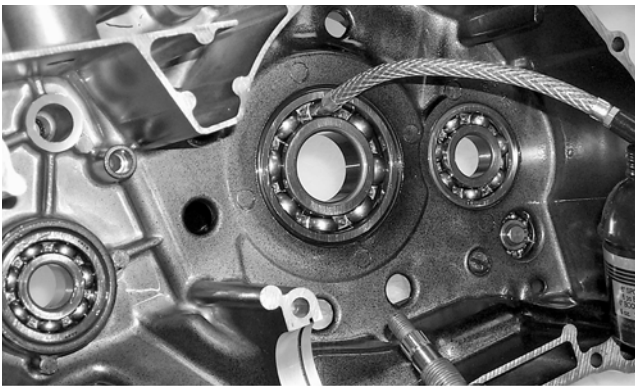

CC688

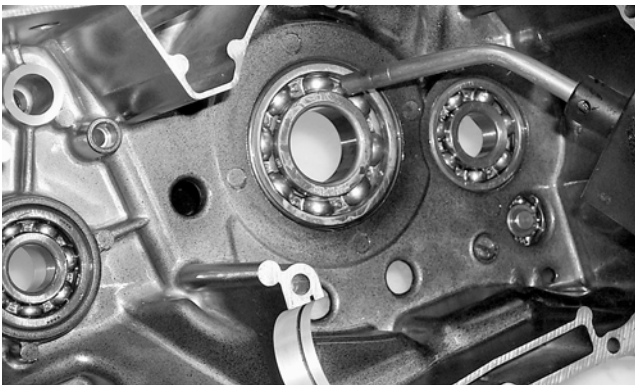

CC689

■ **NOTE:** If heating the bearing is not possible, the crankshaft can be installed using a crankshaft installing tool.

3. Install the crank balancer.

■ **NOTE:** It will be necessary to rotate the crank balancer until the counterweight is directed away from the crankshaft; then rotate the crankshaft clockwise into the journal area to allow the balancer to be fully seated.

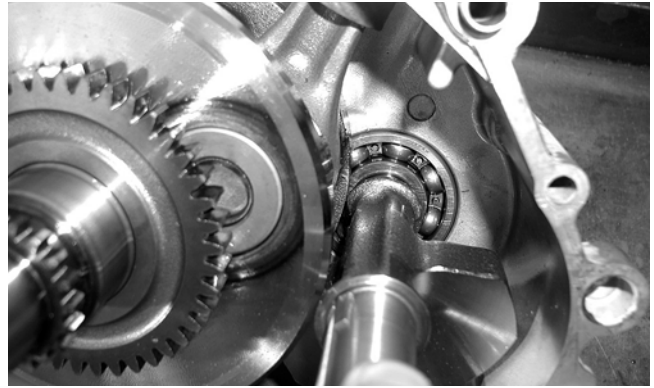

CD832A

4. With the key in position, slide the driven gear onto the crank balancer making sure the timing marks are aligned.



CD826

5. Place the bearing C-ring into position in the crankcase; then install the front output shaft and rear shaft assemblies.

CAUTION
The bearing pins must be positioned into the crankcase correctly or damage to the crankcase may occur.

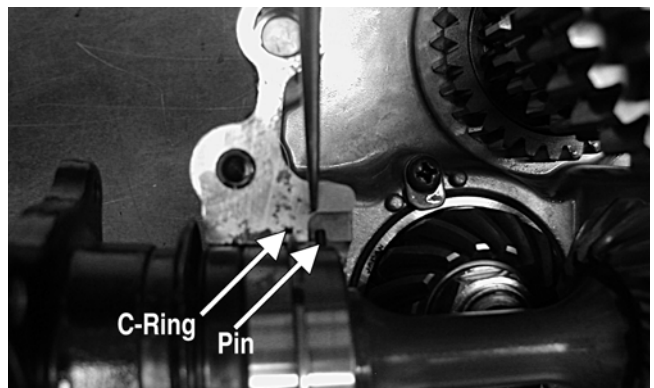

CD268A

6. Simultaneously, install the driveshaft and countershaft assemblies making sure the washer is on the countershaft.

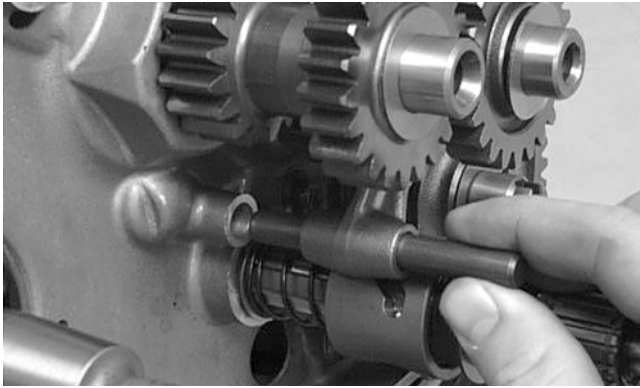

CC330D

15. Insert the pin into the starter gear assembly boss in the crankcase; then install starter idler gear #1.

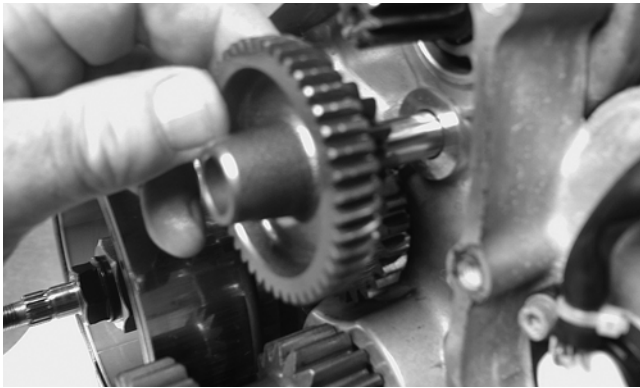

CD136

16. Place a washer on each end of the starter gear assembly and install in the crankcase.
17. Place a thrust washer onto the crankshaft; then install the starter clutch gear assembly onto the crankshaft. Place the key into its notch.



CD155

18. Place the rotor/flywheel into position on the crankshaft; then install the nut on the crankshaft and tighten until the rotor/flywheel is properly seated. Tighten to specifications.

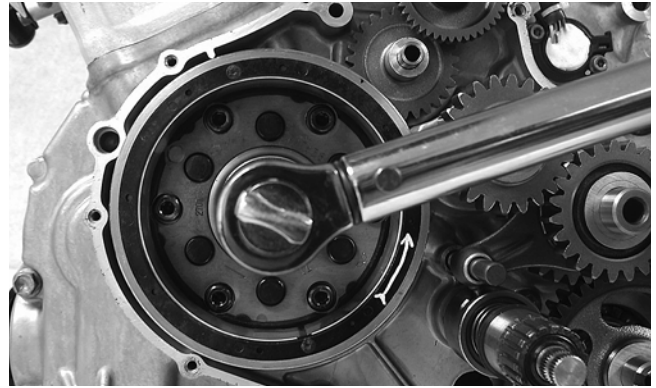

CD444

19. Install the two alignment pins into the left crankcase half.

■ **NOTE:** Make sure that four washers, one bushing, and two alignment pins are in place.

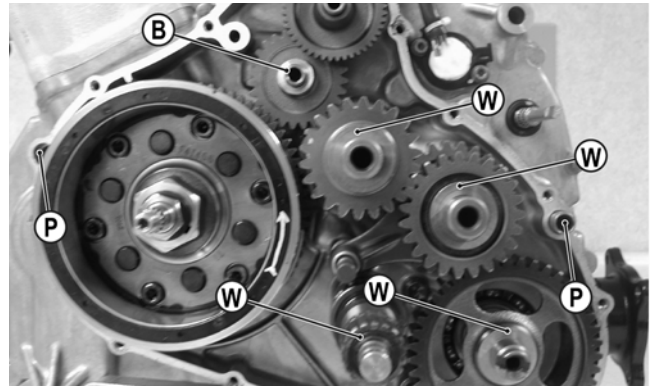

CD134A

3

C. Cover
D. Speed Sensor Housing
E. Hi/Low Shifter Assembly
F. Recoil Starter

■ **NOTE:** Steps 1-19 in the preceding sub-section must precede this procedure.

20. Place the gasket and left-side cover into position on the crankcase.

■ **NOTE:** It may be necessary to push or pull the splined Hi/Low range shift shaft to establish cover/crankcase mating.

21. Install the fourteen cap screws to secure the left-side cover. Do not tighten at this time. Note the location of the long cap screw with rubber washer.

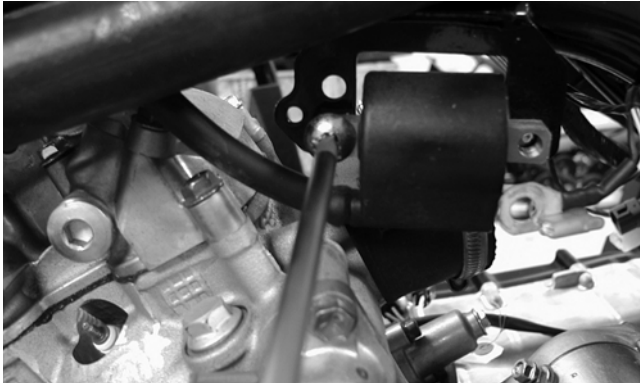

CD814

11. Connect the upper coolant hose to the thermostat housing and secure with the clamp.

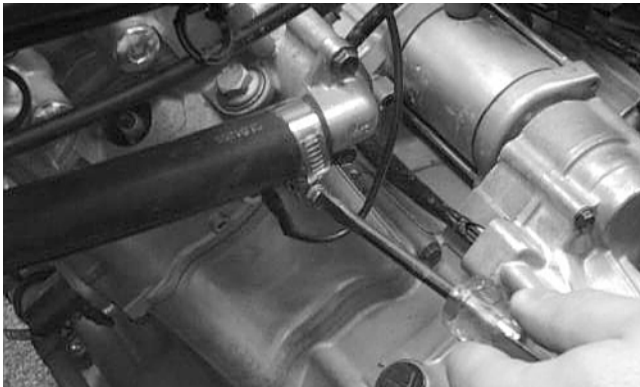

CC121D

12. Install the air filter housing; then connect the crankcase breather and the inlet air duct. Secure with the clamps.



CD785



CD787

13. Position the carburetor into the intake pipe and secure with the clamp; then connect the carburetor boot to the air filter housing. Secure with the clamp.



CD790



CD786

14. Connect the speed sensor connector to the sensor housing.

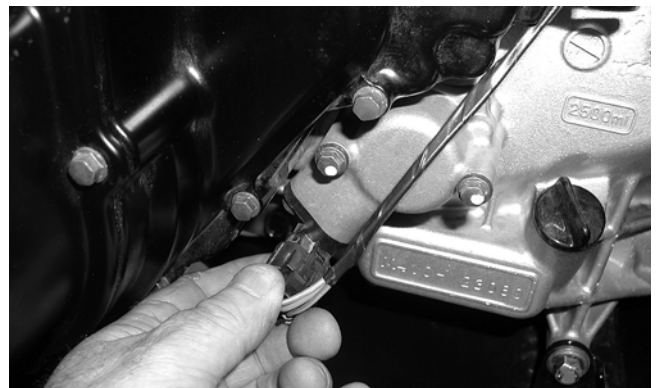

CD794

15. Install the exhaust pipe and secure with two cap screws making sure the mounting brackets engage the frame grommets; then install the muffler with the springs. Tighten all hardware to specifications.

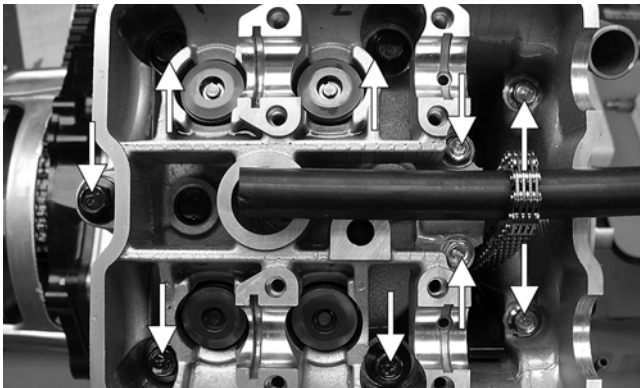

F1133A

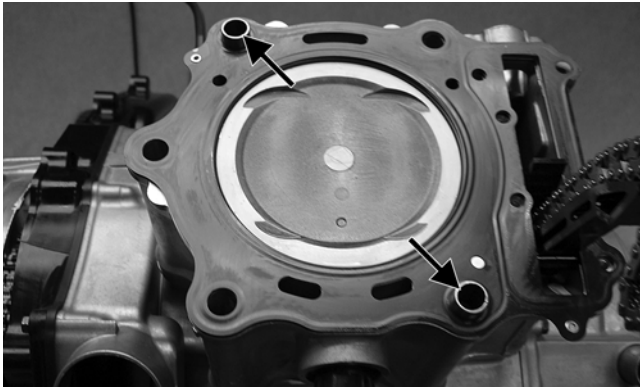

F1134A

👉 AT THIS POINT
 To service valves and cylinder head, see Servicing Top-Side Components sub-section.

👉 AT THIS POINT
 To inspect cam chain guide, see Servicing Top-Side Components sub-section.

C. Cylinder
D. Piston

■ **NOTE:** Steps 1-12 in the preceding sub-section must precede this procedure.

13. Remove the cam chain guide; then remove the two nuts from the cylinder base mounting studs.

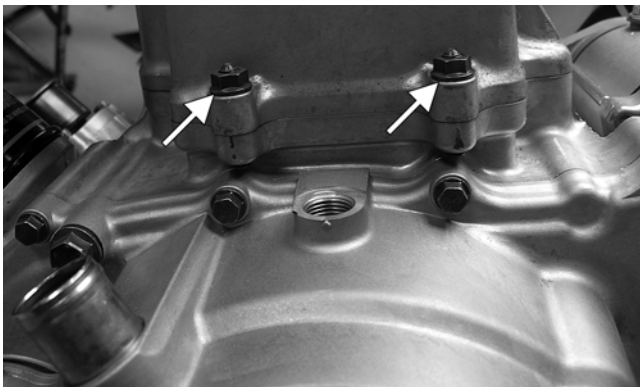

F1135A

14. Lift the cylinder off the crankcase taking care not to allow the piston to drop against the crankcase. Account for the gasket and two alignment pins.



F1136A

👉 AT THIS POINT
 To service cylinder, see Servicing Top-Side Components sub-section.

⚠ CAUTION
 When removing the cylinder, make sure to support the piston to prevent damage to the crankcase and piston.

3

15. Note the position of the orientation dot on the piston; then remove the piston pin circlips using care not to drop the circlip into the crankcase.



F1138A



F1139

16. Remove the piston pin and the piston.

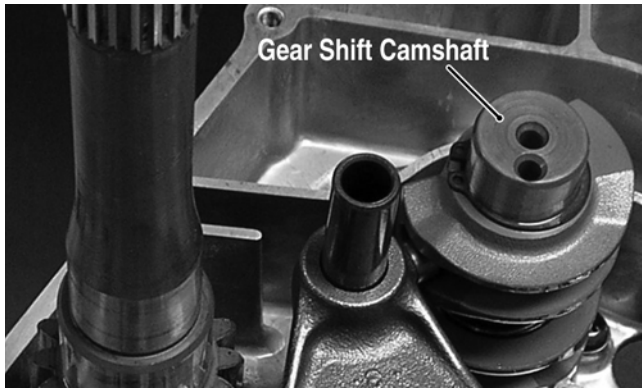

F1282B

- Remove the countershaft assembly (D). Account for a washer on the end of the countershaft.



F1343

■ **NOTE:** Do not disassemble the countershaft assembly unless necessary. If necessary, see Servicing Center Crankcase Components sub-section.

- Using a small chisel or screwdriver, unlock the drive bevel gear nut; then hold the output driven gear with a suitable holding tool and remove the drive bevel gear nut.



F1349

- Using a rubber mallet, tap the output driveshaft from the bearing. Account for a shim, driven bevel gear, washer, and nut.

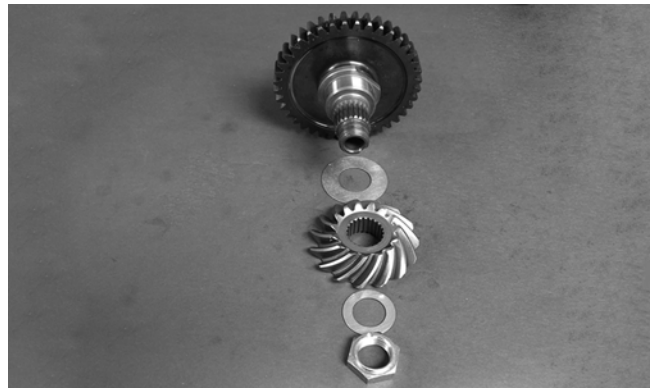

F1407

⚠ CAUTION

Do not attempt to separate the output driven gear from the output driveshaft. They are serviced as an assembly only.

- Remove the front and rear crankshaft balancers; then install the magneto cover on the left crankcase half.
- Using Crankcase Separator/Crankshaft Remover (p/n 0444-009), remove the crankshaft assembly from the bearing; then remove the magneto cover.

3

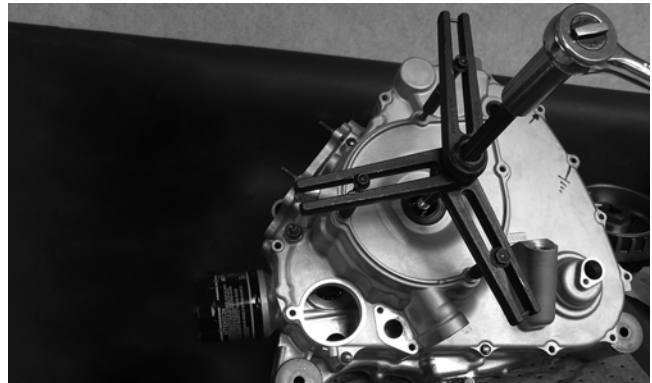

F1252

Assembling/Installing

1. If removed, insert the spiral spring into the case with the outer end of the spring around the mounting lug in the case; then wind it in a counterclockwise direction until the complete spring is installed.

■ **NOTE:** The spiral spring must seat evenly in the recoil case.



B606D

2. Insert the rope through the hole in the reel and tie a knot in the end; then wrap the rope counterclockwise around the reel leaving approximately 50 cm (20 in.) of rope free of the reel.
3. Apply low-temperature grease to the spring and hub.
4. Thread the end of the rope through the guide hole of the case; then thread the rope through the handle and secure it with a double knot. Install the protective cover into the handle.
5. Align the inner hook of the spiral spring with the notch in the reel.

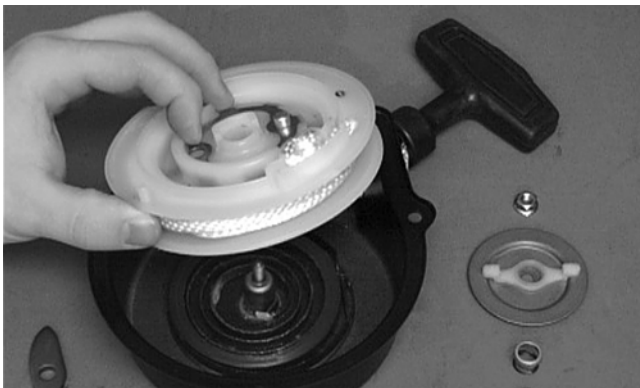

B605D

6. Install the ratchet making sure the end is properly installed on the reel.



B604D

7. Install the friction spring and the spring cover.

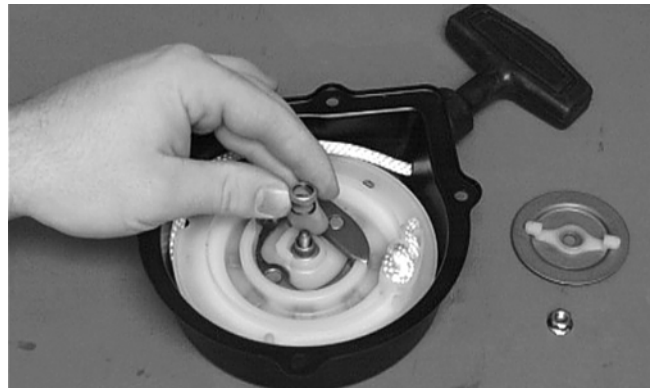

B603D

8. Install the friction plate with the ratchet guide fitting into the ratchet.

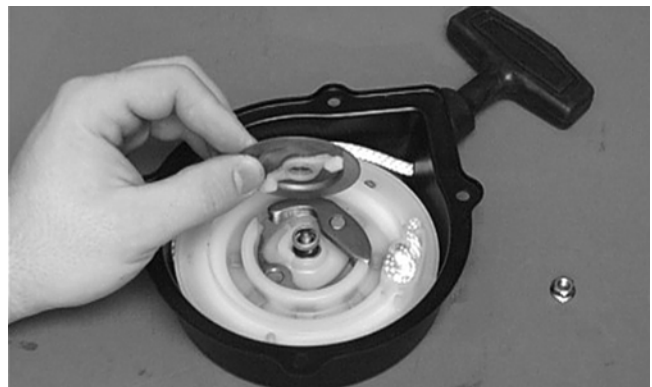

B602D

9. While pushing down on the reel, install the nut. Tighten securely.

3

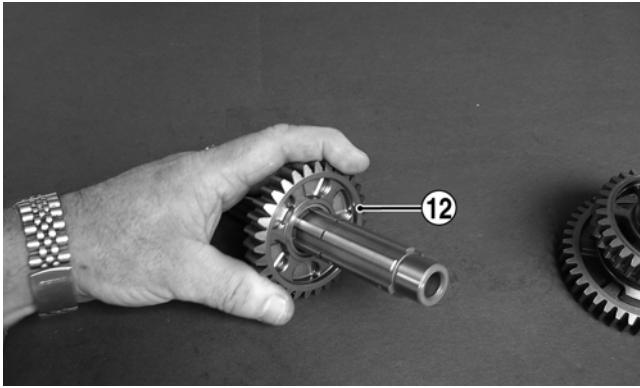

FI398A

2. Install the high driven gear spacer (10) and high driven clutch dog (11).

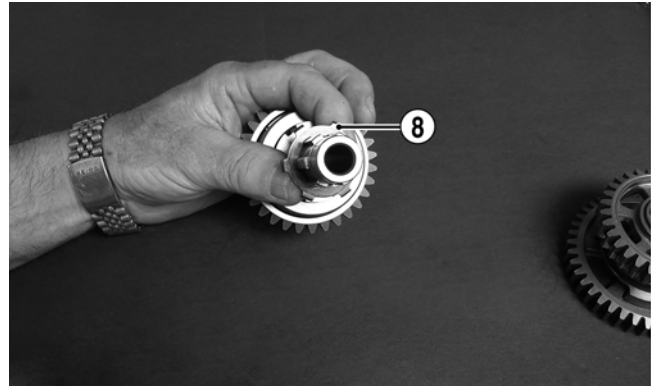

FI395A

4. Install the reverse driven gear bushing (7) making sure to align the oil hole in the bushing with the oil hole in the countershaft; then install the reverse driven gear (6), low/reverse clutch dog (5), and low/reverse spacer (4).

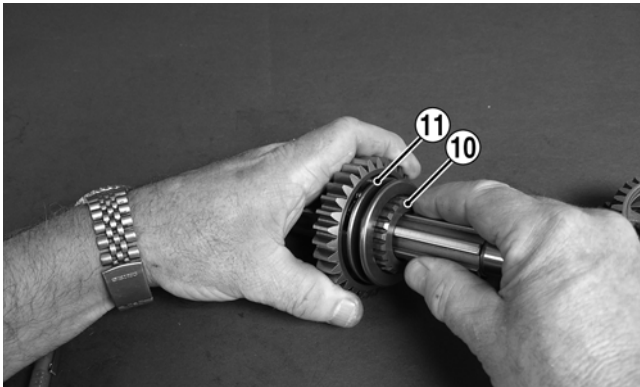

FI402A

3. Position the thrust washer (9) onto the countershaft; then while pressing toward the driven gear, rotate the thrust washer to engage the splines and install the locking tab washer (8) making sure the tabs engage the splines.

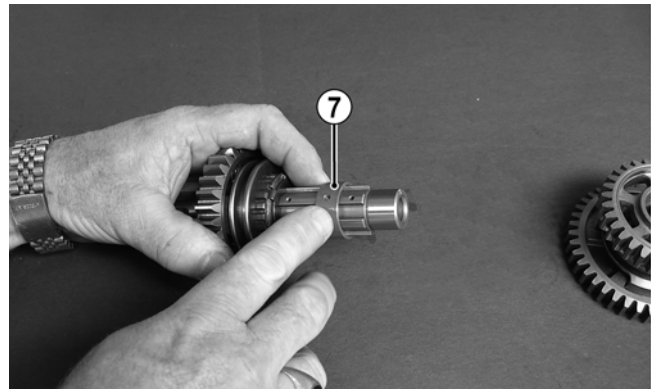

FI393A

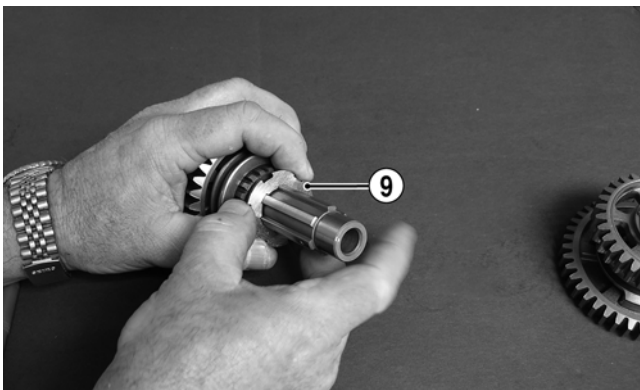

FI396A

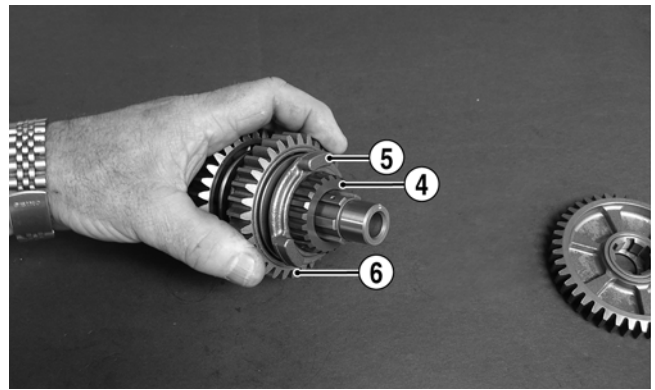

FI392A

5. Install the low driven bushing (3) making sure the oil hole in the bushing aligns with the hole in the countershaft; then install the low driven gear (2) and the thrust washer (1).

- Place the gasket and recoil starter assembly into position on the left-side cover; then tighten four cap screws to specifications.

Installing Top-Side Components

A. Piston B. Cylinder

KEY

- Cylinder
- Stud Bolt
- Nut
- Cylinder Gasket
- Pin
- Water Hose Union
- Cap Screw
- O-Ring

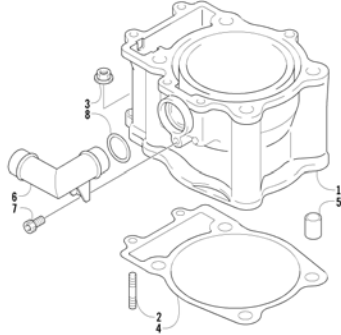

0732-301

■ **NOTE:** If the piston rings were removed, install them in this sequence.

- Install ring expander (4) in the bottom groove of the piston; then install the thin oil rings (3) over the expander making sure the expander ends do not overlap. Stagger the end gaps of the upper and lower thin oil rings according to the illustration.

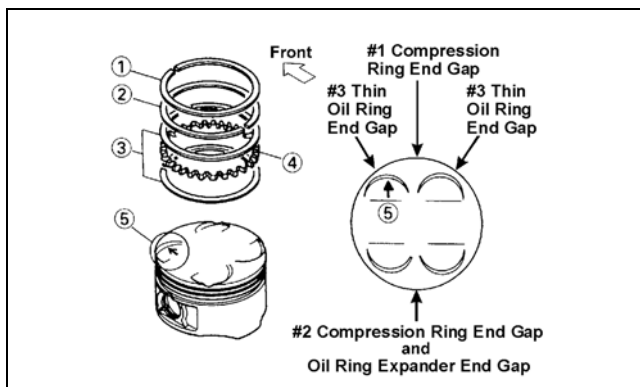

ATV-1085B

■ **NOTE:** Note the direction of the exhaust side of the piston (5) for correct ring end gap orientation.

- Install the middle ring (2) so the letters RN are directed toward the top of the piston; then install the top ring (1) with the lip directed toward the top of the piston.

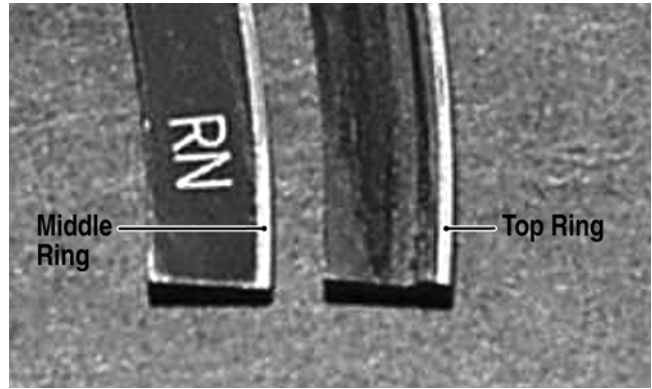

F1168A

⚠ CAUTION

Incorrect installation of the piston rings will result in engine damage.

- Install the piston on the connecting rod making sure there is a circlip on each side and the open end of the circlip faces upwards.

■ **NOTE:** The piston should be installed so the orientation dot is directed toward the exhaust.

3

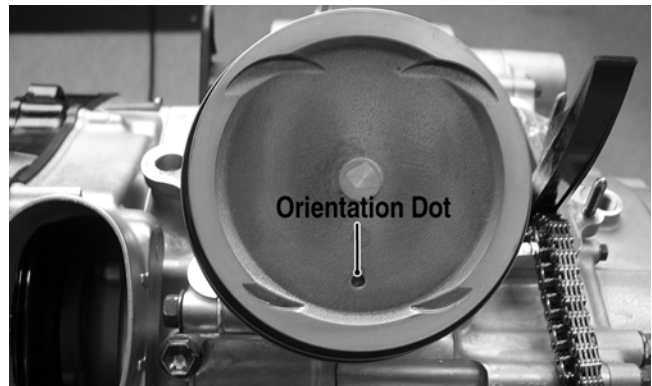

F1138A

- Place the two alignment pins into position. Place the cylinder gasket into position; then place a piston holder (or suitable substitute) beneath the piston skirt and square the piston in respect to the crankcase.



F1136A

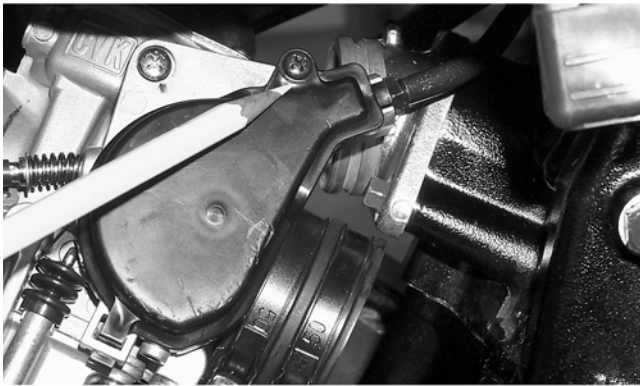

CC743

6. Remove the throttle cable from the actuator arm.

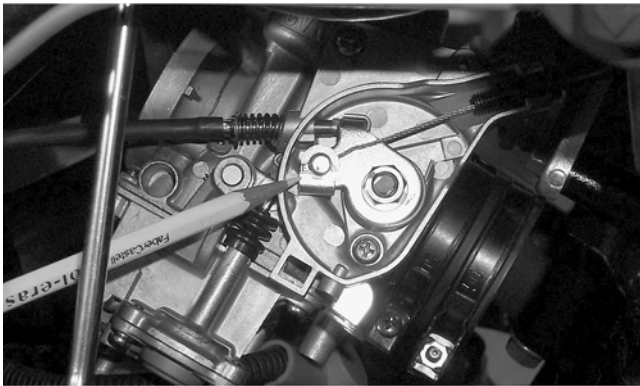

CC742

7. Loosen the outer jam nut securing the throttle cable to the carburetor body; then route the cable out of the way.

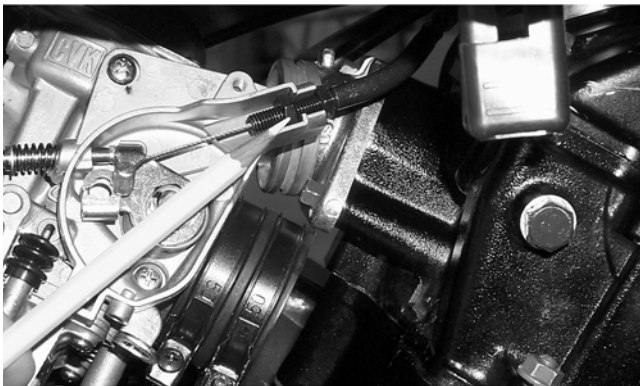

CC741

8. Disconnect the electric choke lead from the wiring harness.

9. Disconnect the vent hose; then remove the carburetor.

DISASSEMBLING

1. Remove the four Phillips-head screws securing the top cover; then remove the cover.

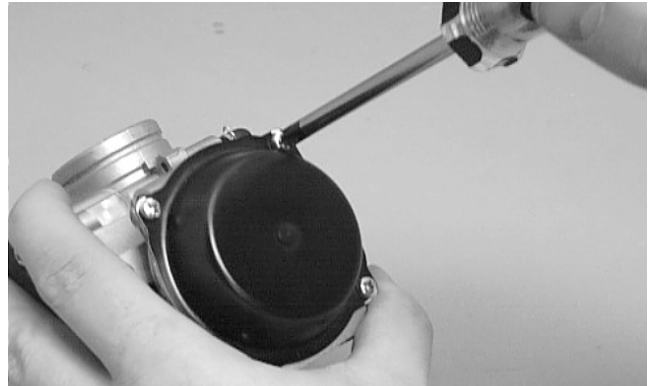

CH015D

2. Remove the vacuum piston assembly from the carburetor body. Account for a spring, spring seat, and the jet needle.

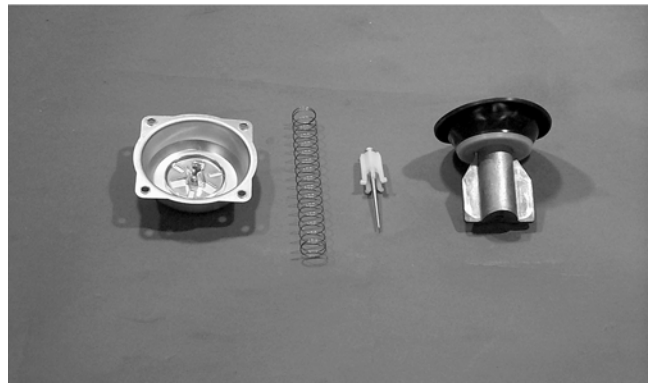

CC746

3. Remove the three screws securing the pump housing. Account for the diaphragm assembly, spring, and U-ring (in the housing).

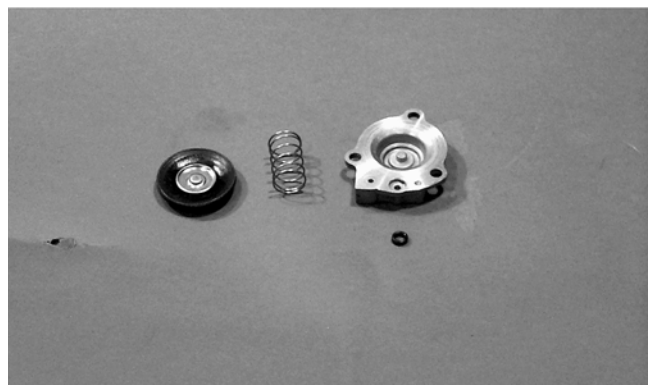

CC748

4. Remove the Phillips-head screws securing the float chamber; then remove the chamber. Account for the O-ring.

Liquid Cooling System (500/650 H1/700 EFI)

The cooling system should be inspected daily for leakage and damage. Also, the coolant level should be checked periodically.

To check the cooling system, see Section 2.

Radiator

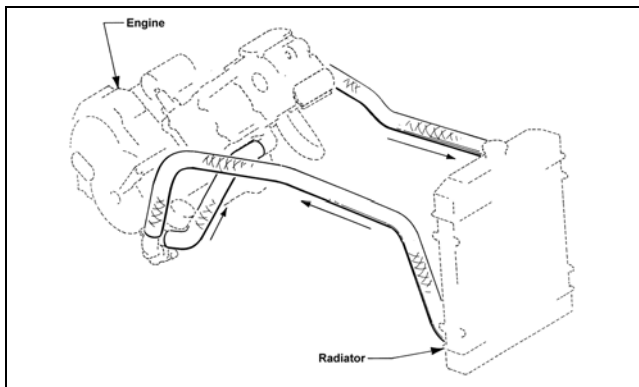

0732-411

REMOVING

1. Drain the coolant at the engine.
2. Remove the front rack (see Section 8).
3. Remove the front bumper and front fender panel (see Section 8).
4. Remove the upper and lower coolant hoses.
5. Remove the cap screws and nuts securing the radiator to the frame.
6. Disconnect the fan wiring from the main wiring harness; then remove the radiator/fan assembly and account for the grommets and collars.
7. Remove the fan/fan shroud assembly from the radiator.

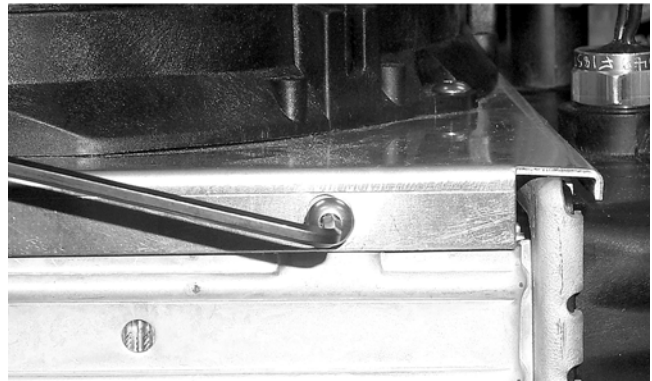

CC863

CLEANING AND INSPECTING

■ **NOTE:** Whenever a part is worn excessively, cracked, or damaged in any way, replacement is necessary.

1. Flush the radiator with water to remove any contaminants.
2. Inspect the radiator for leaks and damage.
3. Inspect all hoses for cracks and deterioration.
4. Inspect all fasteners and grommets for damage or wear.

4

INSTALLING

1. Position the fan/fan shroud assembly on the radiator; then secure with existing hardware.
2. Place the radiator with grommets and collars into position on the frame; then install the cap screws and nuts. Tighten securely.
3. Install the upper and lower coolant hoses; then secure with hose clamps.

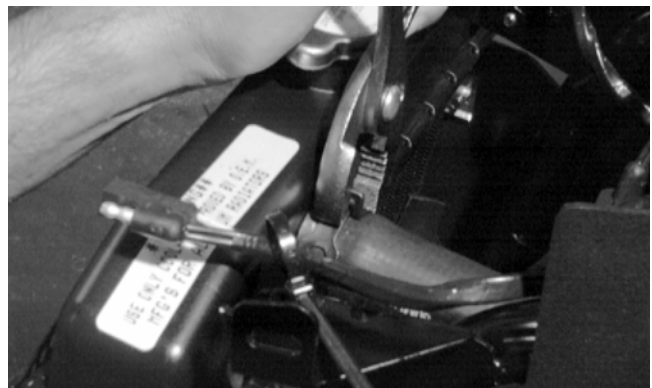

AF734D

4. Install the front bumper and front fender panel (see Section 8).
5. Install the front rack (see Section 8).

Accessory Receptacle/Connector

■ **NOTE:** This test procedure is for either the receptacle or the connector.

VOLTAGE

1. Turn the ignition switch to the ON position; then set the meter selector to the DC Voltage position.
2. Connect the red tester lead to the red/white wire or the positive connector; then connect the black tester lead to ground.
3. The meter must show battery voltage.

■ **NOTE:** If the meter shows no battery voltage, troubleshoot the battery, fuse, receptacle, connector, or the main wiring harness.

Brakelight Switch (Auxiliary)

The switch connector is the two-prong connector on the brake switch lead above the transmission.

■ **NOTE:** The ignition switch must be in the ON position.

VOLTAGE (Wiring Harness Side)

1. Set the meter selector to the DC Voltage position.
2. Connect the red tester to the orange wire; then connect the black tester lead to ground.



AR627D

3. The meter must show battery voltage.

■ **NOTE:** If the meter shows no battery voltage, troubleshoot the battery, fuse, switch, or the main wiring harness.

■ **NOTE:** If the meter shows battery voltage, the main wiring harness is good; proceed to test the switch/component, the connector, and the switch wiring harness for resistance.

RESISTANCE (Switch Connector)

⚠ CAUTION

Always disconnect the battery when performing resistance tests to avoid damaging the multimeter.

1. Set the meter selector to the OHMS position.
2. Connect the red tester lead to one black wire; then connect the black tester lead to the other black wire.

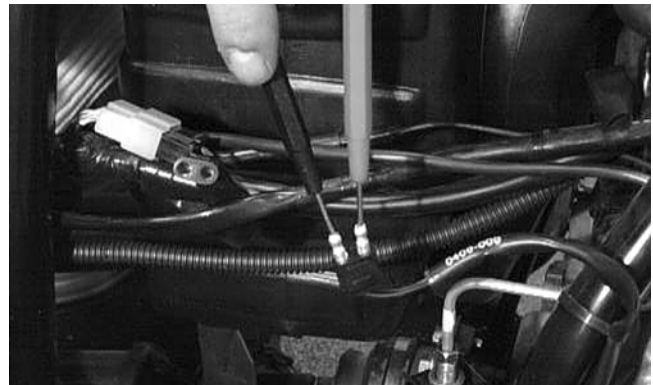

AR626D

3. When the brake pedal is depressed, the meter must show less than 1 ohm.

■ **NOTE:** If the meter shows more than 1 ohm of resistance, replace the switch.

Brakelight Switch (Handlebar Control)

To access the connector, remove the access panel.

■ **NOTE:** The ignition switch must be in the ON position.

VOLTAGE (Wiring Harness Connector)

1. Set the meter selector to the DC Voltage position.
2. Connect the red tester lead to the orange wire; then connect the black tester lead to ground.



CD576



CF094C

4. If the differential lock engages (front wheels locked) and the voltage does not drop to 0, the switch is faulty and must be cleaned or replaced.

Magneto Coils (400/500/650 H1)

VOLTAGE (Stator Coil - Regulated Output)

1. Set the meter selector to the DC Voltage position.
2. Connect the red tester lead to the positive battery post; then connect the black tester lead to the negative battery post.
3. With the engine running at a constant 5000 RPM (with the headlights on), the meter must show 14-15.5 DC volts.

⚠ CAUTION

Do not run the engine at high RPM for more than 10 seconds.

■ **NOTE:** If voltage is lower than specified, test stator coil - no load.

VOLTAGE (Stator Coil - No Load)

The connector is the black three-pin one on the right side of the engine just above the starter motor.

■ **NOTE:** Test the connector that comes from the engine.

1. Set the meter selector to the AC Voltage position.
2. Test between the three black wires for a total of three tests.
3. With the engine running at the specified RPM, all wire tests must show 60 AC volts.

⚠ CAUTION

Do not run the engine at high RPM for more than 10 seconds.

■ **NOTE:** If both stator coil tests failed, check all connections, etc., and test again. If no voltage is present, replace the stator assembly.

RESISTANCE (Charging Coil)

⚠ CAUTION

Always disconnect the battery when performing resistance tests to avoid damaging the multimeter.

1. Set the meter selector to OHMS position.
2. Test between the three black wires for a total of three tests.
3. The meter reading must be within specification.

RESISTANCE (Trigger Coil)

⚠ CAUTION

Always disconnect the battery when performing resistance tests to avoid damaging the multimeter.

1. Disconnect the gray four-pin connector on the right side of the engine just above the starter motor.
2. Set the meter selector to the OHMS position.
3. Connect the red tester lead to the green wire; then connect the black tester lead to the blue wire. The meter reading must be within specification.

ECU Error Code List

- EC00 = No Fault Detected
- EC12 = CKP (Crankshaft Position) Sensor
- EC13 = APS (Air Pressure Sensor)
- EC14 = TPS (Throttle Position Sensor)
- EC15 = Water Temperature Sensor
- EC20 = Differential Lock Relay
- EC21 = Air Temperature Sensor
- EC23 = Tilt Sensor
- EC24 = Ignition Coil #1
- EC32 = Fuel Injector #1
- EC40 = ISC Valve
- EC41 = Fuel Pump Relay
- EC99 = Start Not Possible

■ **NOTE:** EC99 indicates that the engine will not start and that the spark plug and fuel pump are disabled. EC99 will be displayed following EC23 (Tilt Sensor), EC24 (Ignition Coil), etc.

To clear an error code after repairs or adjustments are made, install the Diagnostic Harness (p/n 0486-219) by connecting it to the diagnostic plug; then turn the ignition switch to the ON position. After three seconds, turn the ignition switch to the OFF position and disconnect the diagnostic harness. When the ignition switch is turned on, the error code should not be displayed.

Tilt Sensor (700 EFI)

⚠ WARNING

Incorrect installation of the tilt sensor could cause sudden loss of engine power which could result in loss of vehicle control resulting in injury or death.

⚠ CAUTION

Do not drop the tilt sensor as shock can damage the internal mechanism.

SUPPLY VOLTAGE

1. Disconnect the three-wire connector from the sensor; then select DC Voltage on the multimeter and connect the red tester lead to the orange wire (C) and the black tester lead to the black wire (A).

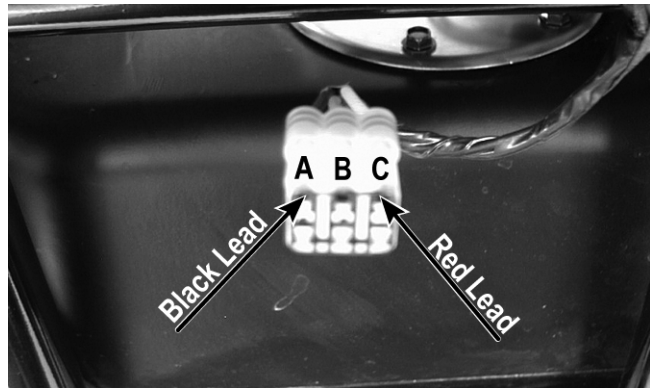

CD706A

2. Turn the ignition switch to the ON position. The multimeter should read battery voltage. If battery voltage is not indicated, check the 30-amp fuse, wiring harness, or the ignition switch.
3. Remove the red tester lead and connect to the blue/brown wire (B). The multimeter should read 0 DC volts. If the specified voltage is not indicated, check wire connections at the CDI or substitute another CDI to verify the test.

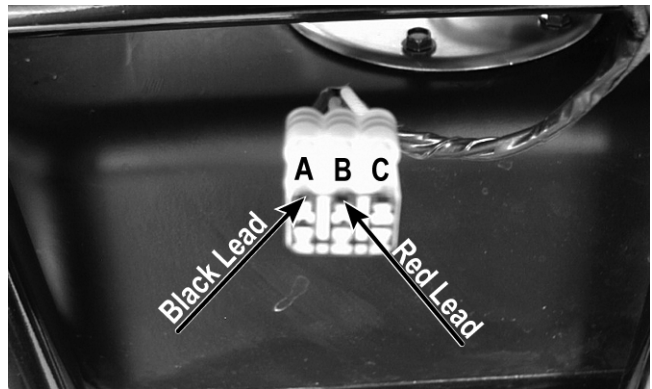

CD706B

OUTPUT VOLTAGE

■ **NOTE:** Needle adapters will be required on the multimeter leads as the following tests are made with the sensor connected.

1. Connect the three-wire plug to the sensor; then remove the right-side mounting screw securing the sensor to the rear frame.

5



KX159

Disassembling Input Shaft

■ **NOTE:** This procedure can be performed on a rear gear case; however, some components may vary from model to model. The technician should use discretion and sound judgment.

1. Using a T-40 torx wrench, remove the cap screws securing the pinion housing.



CD102

2. Using a rubber mallet, remove the housing. Account for a gasket. Remove the fork, collar, and spring. Note the location of all the components for assembling purposes.

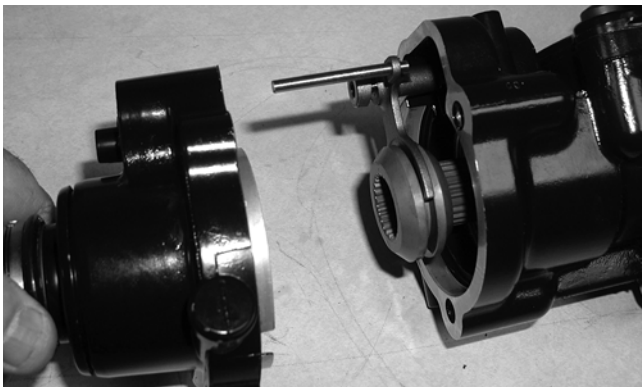

CD103

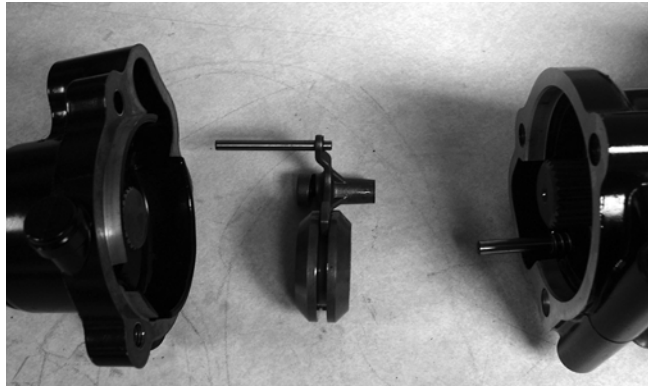

CD106

3. Using a side-cutter (or suitable substitute), remove the boot clamps; then remove the boots and splined drive from the input shaft.



CD114

4. Remove the input shaft from the pinion housing.



CD107

5. Using a seal removal tool, remove the input shaft seal. Account for a spacer.

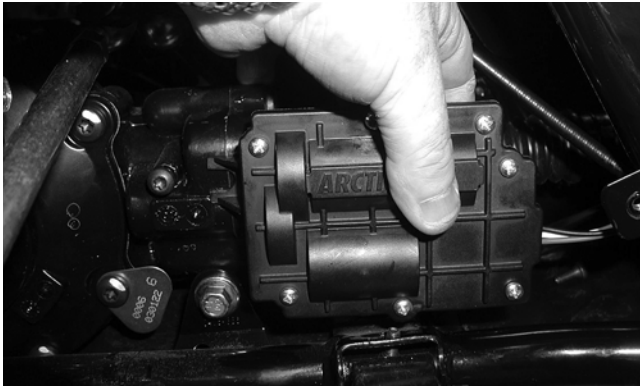

AG925

4. Install the inner fender panels.
5. Install the front axles (see Drive Axles in this section).
6. Secure the upper A-arms with cap screws and lock nuts. Tighten to specifications.



AF610D

7. Secure the lower shock eyelets with cap screws and lock nuts. Tighten to specifications.

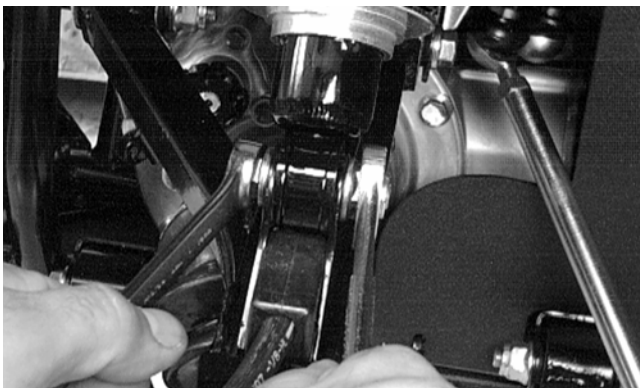

AF897D

8. Secure the tie rods with the lock nuts. Tighten to specifications; then install and spread the cotter pins.



AF896D



AF895D

9. Making sure that each caliper has the 0.76 mm (0.030 in.) spacer washers between the caliper and the knuckle, install the brake calipers. Secure with the cap screws tightened to specifications.



AF894D

10. Install the wheels and tighten to specifications.
11. Remove the ATV from the support stand.

6

- Place bushings and sleeves (where appropriate) into shock eyelet; then install shock with two cap screws and nuts. Tighten all nuts to specifications.

⚠ CAUTION

Do not tighten the nuts beyond the 4.8 kg-m (35 ft-lb) specification or the shock eyelet or mount WILL be damaged.

■ **NOTE:** The rear shock absorber-to-lower A-arm torque factor is 2.8 kg-m (20 ft-lb).

- Remove the ATV from the support stand.

Front A-Arms

REMOVING

- Secure the ATV on a support stand to elevate the front wheels; then remove the wheels.

⚠ WARNING

Make sure the ATV is solidly supported on the support stand to avoid injury.

- Remove the cotter pin from the nut. Discard the cotter pin.



CD008

- Remove the nut securing the hub.
- Remove the brake caliper. Account for two cap screws and two 0.76 mm (0.030 in.) spacer washers.

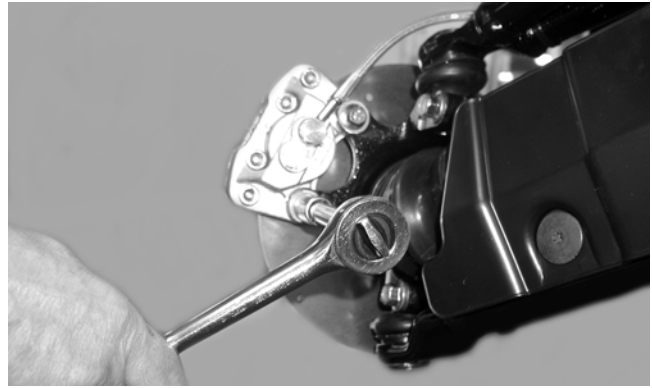

CD007

- Remove the hub assembly.
- Remove the cotter pin and slotted nut securing the tie rod end to the knuckle; then remove the tie rod end from the knuckle.



AF618D

- Remove the cap screws securing the ball joints to the knuckle.

⚠ CAUTION

Support the knuckle when removing the cap screws or damage to the threads will occur.

7



AF628D

- Tap the ball joints out of the knuckle; then remove the knuckle.
- Remove the lower shock absorber eyelet from the upper A-arm.

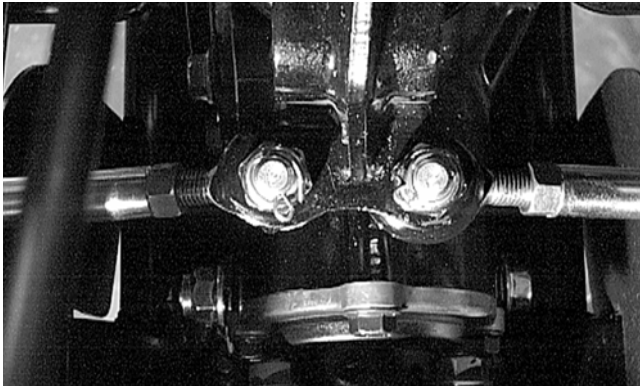

AF778D

4. Install the splash panels; then install the front wheels and tighten to specifications using a crisscross pattern.
5. Lower the ATV and place the handlebar and caps into position on the steering post; then position the speedometer on top of the caps and secure with the four cap screws. Tighten to specifications.
6. Install the storage compartment box; then attach the storage compartment cover assembly by engaging the lugs into the slots and sliding rearward. Lock the storage compartment lid to hold the assembly in place.



CD671

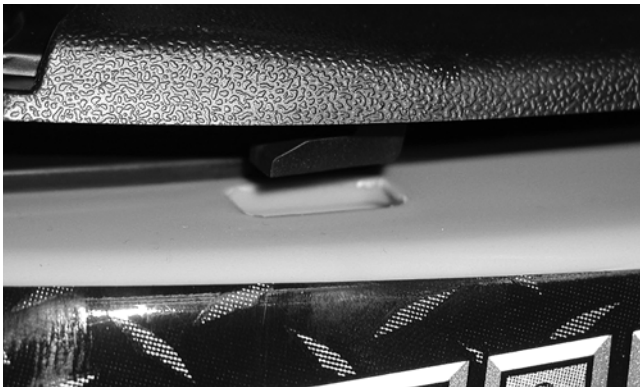

CD670

7. Place the instrument pod into position over the speedometer; then secure with two reinstallable rivets and the ignition switch locking ring.



CD677



CD676

8. Install the steering post access cover and secure with four reinstallable rivets; then install and secure the radiator access cover.

Handlebar Grip

REMOVING

1. Remove the plug from the head of the rivet.
2. Using a 1/8-in. drill bit, drill out the rivet.
3. Using compressed air between the grip and the handlebar, twist the grip back and forth until it slides free of the handlebar.

INSPECTING

■ **NOTE:** Whenever a part is worn excessively, cracked, or damaged in any way, replacement is necessary.

1. Inspect the grip for wear, cuts, or cracks.
2. Inspect the grip for deterioration.

7. Remove the torx-head cap screws and nylon ties securing the left-side and right-side splash panels; then remove the panels.



CD685

8. Remove one shoulder screw and four plastic rivets on each side to separate the front panel lower fenders from the left-side and right-side footwells.



CD691



CD682

9. Remove the shift knob retaining pin and remove the shift knob; then remove the shift lever pivot axle nut and remove the axle and shift lever. Account for a spring and two O-rings.



CD779

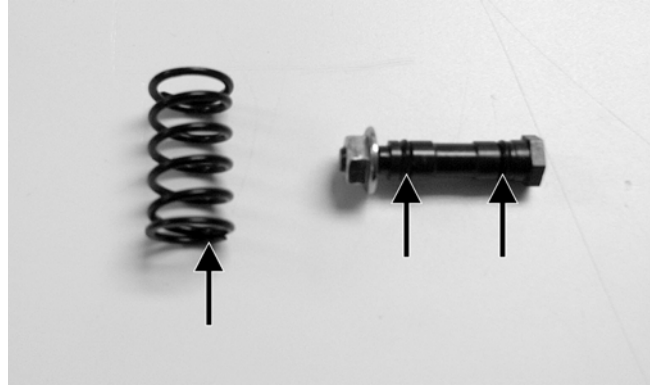

CD780A

10. Disconnect four headlight connectors and secure the wires out of the way; then disconnect the wires to the front accessory plug.



CD681

11. Rotate the handlebar to the full-left position; then lift and slide the panel to the rear and lift the rear up to clear the handlebar.

Hand Brake Lever/ Master Cylinder Assembly

■ **NOTE:** The master cylinder is a non-serviceable component; it must be replaced as an assembly.

REMOVING

1. Slide a piece of flexible tubing over one of the wheel bleeder valves and direct the other end into a container. Remove the reservoir cover; then open the bleeder valve. Allow the brake fluid to drain completely.

■ **NOTE:** Compressing the brake lever several times will quicken the draining process.



AF637D

2. Place an absorbent towel around the connection to absorb brake fluid. Remove the banjo-fitting from the master cylinder. Account for two crush washers and a banjo-fitting bolt.

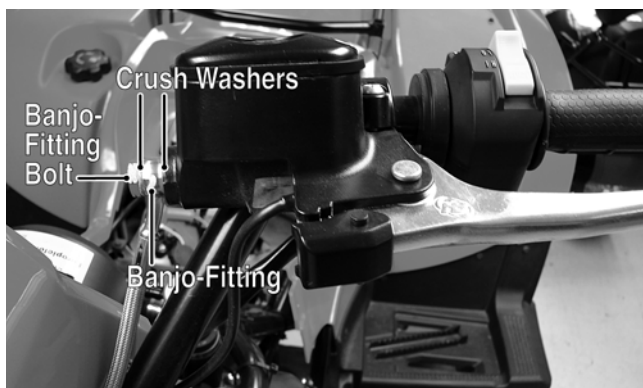

DE059A

⚠ CAUTION

Brake fluid is highly corrosive. Do not spill brake fluid on any surface of the ATV.

3. Remove the circlip and pivot pin securing the brake lever to the master cylinder housing; then remove the brake lever and set aside.

4. Dislodge the brakelight switch from the master cylinder housing by gently pressing it toward the pivot pin hole in the housing; then lay it aside leaving the switch and wiring harness connected.



BC205

5. Remove the clamp screws securing the brake housing to the handlebar; then remove the assembly from the handlebar.

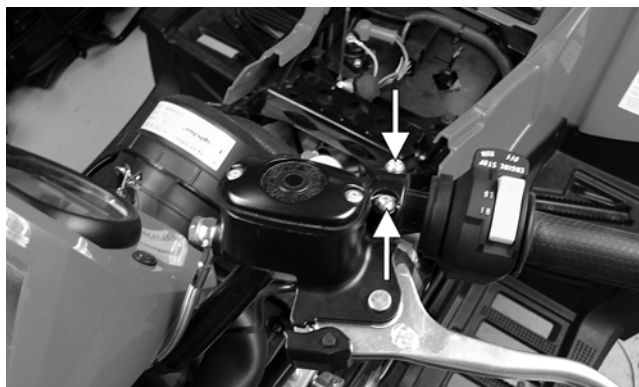

DE058A

INSPECTING

■ **NOTE:** Whenever a part is worn excessively, cracked, or damaged in any way, replacement is necessary.

1. Inspect the pin securing the brake lever for wear.
2. Inspect the brake lever for elongation of the pivot hole.
3. Inspect the reservoir for cracks and leakage.
4. Inspect the banjo-fitting for cracks and deterioration and the condition of the fittings (threaded and compression).
5. Inspect the brakelight switch for corrosion, cracks, missing or broken mounting tabs, or broken and frayed wiring.

■ **NOTE:** If the brakelight switch is determined to be not serviceable, see Section 5.

BRAKE COMPONENTS			
Part	Part Bolted To	Torque	
		kg-m	ft-lb
Brake Disc****	Hub	2.1	15.0
Brake Hose	Caliper	2.8	20.0
Brake Hose	Master Cylinder	2.8	20.0
Brake Hose	Auxiliary Brake Cylinder	2.8	20.0
Master Cylinder Cover	Master Cylinder	0.1	1.0
Auxiliary Brake Pedal	Lever Axle	3.5	25.0
Hydraulic Caliper	Suspension Knuckle	2.8	20.0
CHASSIS COMPONENTS			
Footrest	Frame (8 mm)	2.8	20.0
Footrest	Frame (10 mm)	5.5	40.0
Shift Lever****	Shift Axle	1.1	8.0
SUSPENSION COMPONENTS (Front)			
A-Arm	Frame	4.8	35.0
Ball Joint Cap Screw	Knuckle	4.8	35.0
Shock Absorber	Frame	4.8	35.0
Shock Absorber	Upper A-Arm	4.8	35.0
Knuckle	A-Arm	4.8	35.0
SUSPENSION COMPONENTS (Rear)			
A-Arm	Frame	5.5	40.0
Shock Absorber (Upper)	Frame	4.8	35.0
Shock Absorber (Lower)	Lower A-Arm	2.8	20.0
Knuckle	A-Arm	4.8	35.0

ENGINE/TRANSMISSION			
Clutch Shoe	Crankshaft	15.0	108.0
Clutch Cover/Housing Assembly	Crankcase	0.9	6.5
Crankcase Half (6 mm)	Crankcase Half	1.0	7.0
Crankcase Half (8mm)	Crankcase Half	2.6	19.0
Cylinder Head (Cap Screw)	Crankcase (Step 1) (Step 2)	2.5 3.7	18.0 27.0
Cylinder Head (6 mm)	Cylinder	1.0	7.0
Cylinder Head Cover	Cylinder (Step 1) Head (Step 2)	1.0 1.4	7.0 10.0
Driven Pulley Nut	Fixed Face	10.9	79.0
Fixed Driven**	Clutch Shaft	10.9	79.0
Ground Wire	Engine	1.1	8.0
Magneto Cover	Crankcase	1.1	8.0
Movable Drive Face**	Driveshaft	10.9	79.0
Oil Pump Drive Gear	Crank Balancer Shaft	15.0	108.0
Output Shaft Gear	Output Shaft	10.0	72.0
Recoil Starter	Left-Side Cover	0.8	6.0
Rotor/Flywheel Nut	Crankshaft	16.0	116.0
Cam Idler Shaft	Cylinder Head	4.1	29.5
Starter Cup	Crankshaft	3.8	27.5
V-Belt Cover	Crankcase	0.9	6.5
Spark Plug	Engine	1.1	8.0

* w/Blue Loctite #242

** w/Red Loctite #271

*** w/Green Loctite #609

****w/Blue Loctite #243



Back to TOC

Back to Section TOC



CLICK HERE TO **DOWNLOAD** THE COMPLETE MANUAL

- Thank you very much for reading the preview of the manual.
- You can download the complete manual from: www.heydownloads.com by clicking the link below



- Please note: If there is no response to **CLICKING** the link, please download this PDF first and then click on it.

CLICK HERE TO **DOWNLOAD** THE COMPLETE MANUAL