

YAMAHA

Marine

Outboards

70F/90F

SERVICE MANUAL

CLICK HERE TO **DOWNLOAD** THE COMPLETE MANUAL

- Thank you very much for reading the preview of the manual.
- You can download the complete manual from: www.heydownloads.com by clicking the link below



- Please note: If there is no response to CLICKING the link, please download this PDF first and then click on it.

CLICK HERE TO **DOWNLOAD** THE COMPLETE MANUAL

ROUGH IDLING	9-8
ENGINE STALLS	9-9
ENGINE WILL NOT STOP	9-10
POWER TRIM AND TILT SYSTEM	9-11
GEAR SHIFT IS IMPOSSIBLE OR HARD	9-13
OIL INJECTION SYSTEM	9-14



SPECIAL TOOLS

SPECIAL TOOLS FOR P.T.T. SERVICE

No.	TOOL NAME	PART NUMBER
1	Cylinder end handle	YB-6175
2	Oil pressure gauge	YB-6181
3	Seat installer	YB-6188

SEALING AGENTS AND LUBRICANTS

No.	PART NAME	PART NUMBER
1	Gasket maker	907-90740-01-00
2	Marine grease	LUB-GREAS-14-00
3	Power trim/tilt fluid	LUB-PWRTF-11-00
4	Gear case lube (11 oz)	LUB-GEARL-11-00
5	Yamalube two cycle outboard oil	ACC-11000-07-01

C34000-0*

DIMENSION



D22500-0

FUEL LINE

Check that the fuel line is correctly installed.

70ET

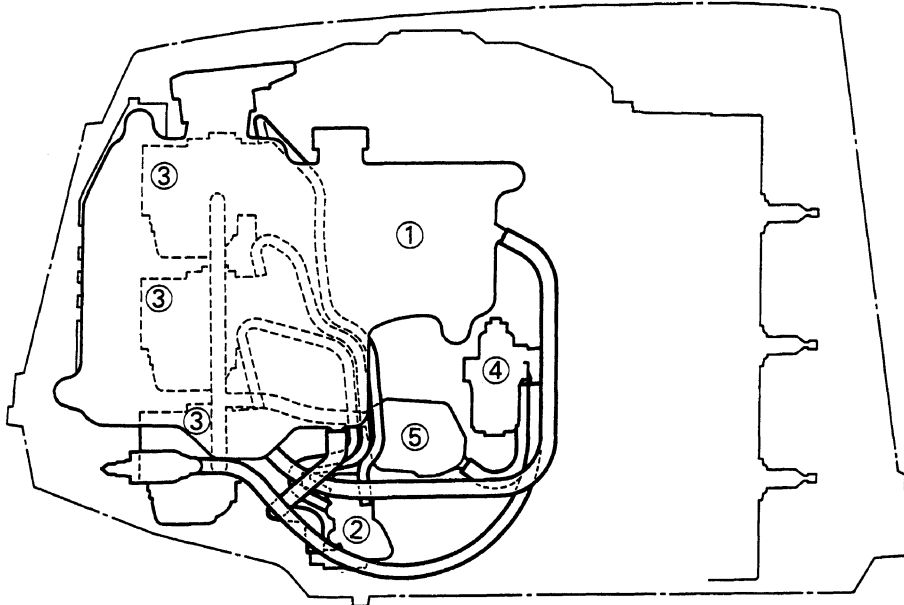

- ① Oil tank
- ② Oil injection pump
- ③ Carburetor
- ④ Fuel filter
- ⑤ Fuel pump

90ET

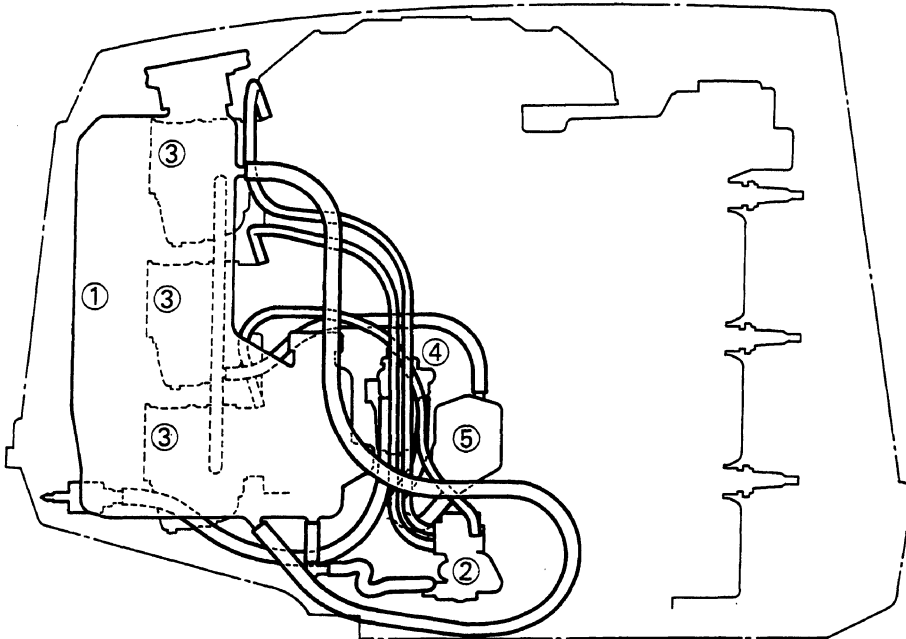

- ① Oil tank
- ② Oil injection pump
- ③ Carburetor
- ④ Fuel filter
- ⑤ Fuel pump

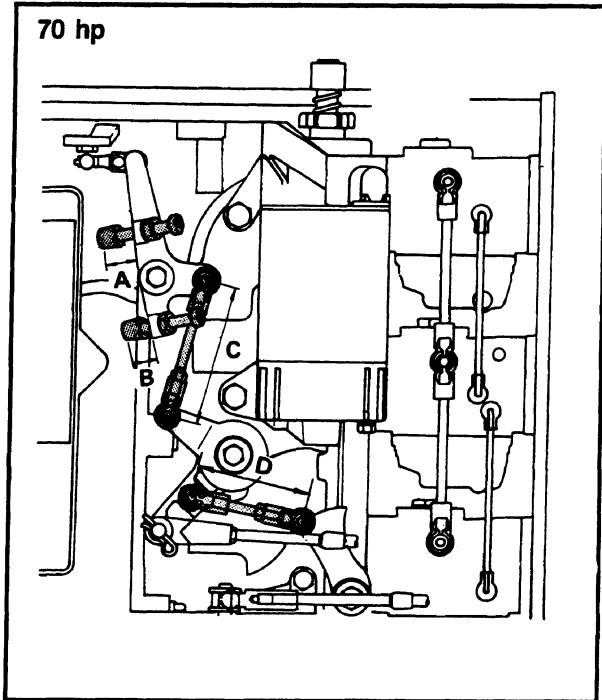

2) Setting the link length
Set the lengths of A, B, C, and D as follows:

70 hp	90 hp
A: 20 mm (0.79 in)	15 mm (0.59 in)
B: 15 mm (0.59 in)	27 mm (1.06 in)
C: 74 mm (2.91 in)	74 mm (2.91 in)
D: 60 mm (2.36 in)	124 mm (4.88 in)

NOTE: _____
These dimensions are temporary settings, so they can be changed when ignition timing is adjusted.

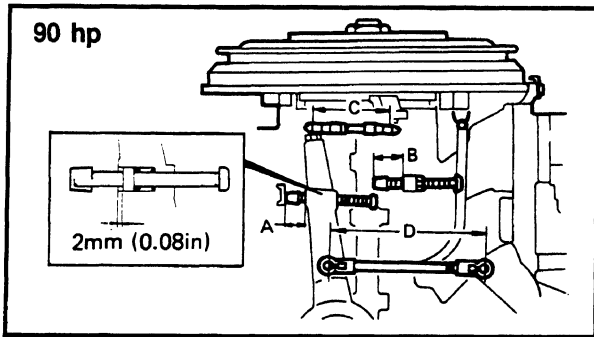

3) Ignition timing adjustment using a timing light.

CAUTION: _____
When checking ignition timing using a timing light, be sure to replace the propeller with the specified test propeller, and make tests with the machine placed in a test tank.

Make sure the engine runs at more than 4,500 rpm.

WARNING: _____
Be careful not to touch any rotating parts (such as the C.D.I. magneto rotor), C.D.I. unit, or ignition coil while making the adjustment.

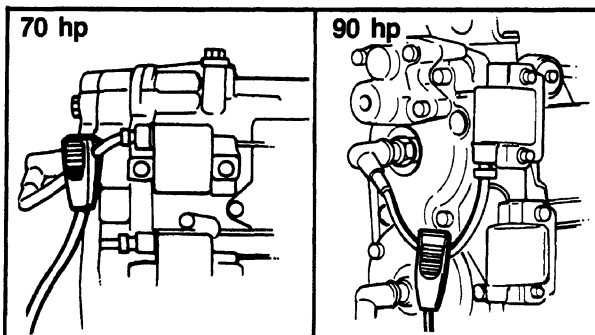

Clip the timing light to the No. 1 cylinder high-tension wire.



E20000-1

FUEL SYSTEM

- ① Carburetor
- ② Fuel pump assembly
- ③ Fuel filter assembly
- ④ Fuel joint
- ⑤ Priming pump
- ⑥ Fuel meter assembly
- ⑦ Fuel tank cap
- ⑧ Fuel tank

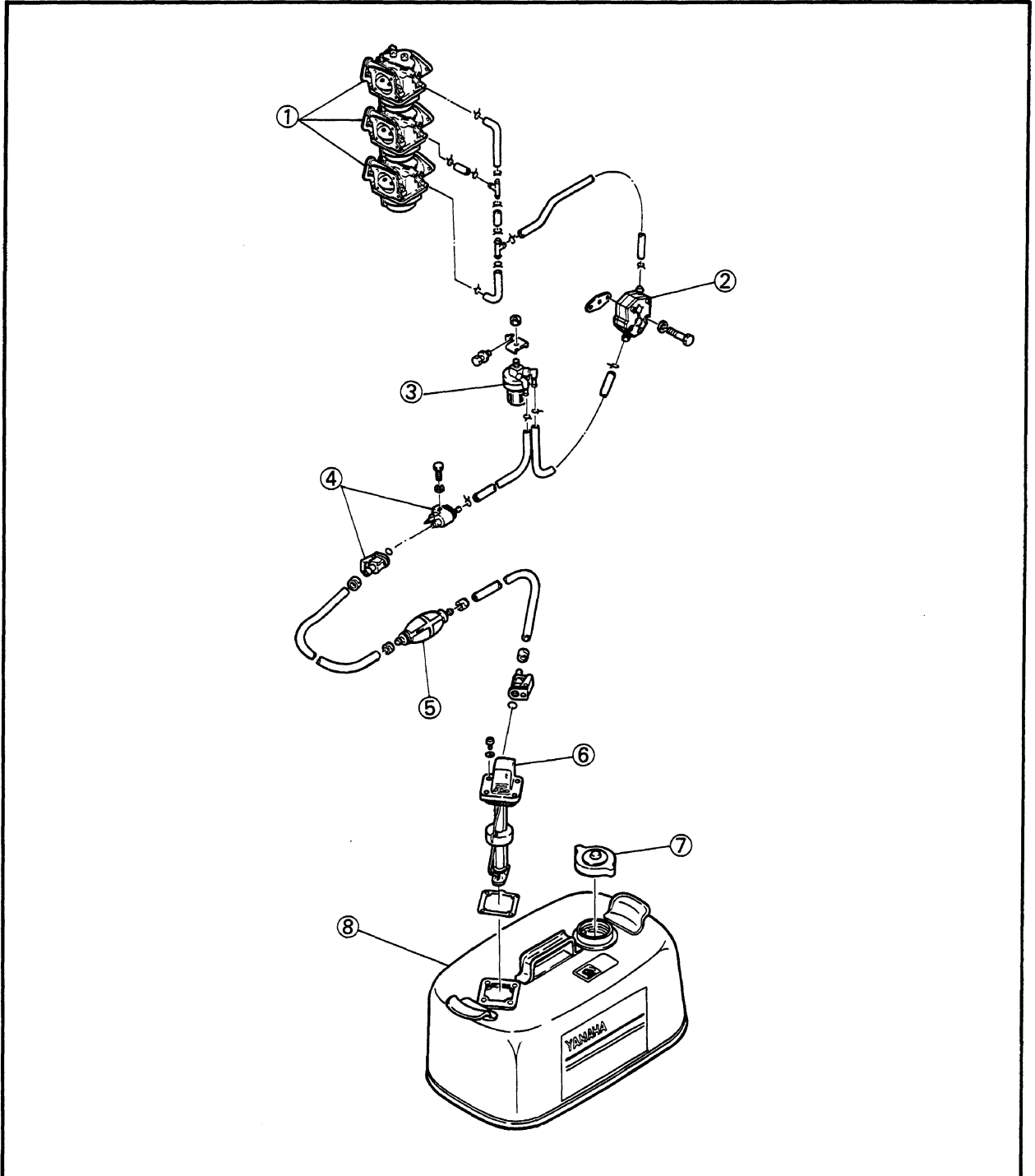



90ET

- | | | |
|----------------------------|----------------------|-------------------------|
| ① Oil injection pump ass'y | ⑭ Link rod | ⑳ Special washer 1 |
| ② Drain plug | ⑮ Link joint | ㉑ Ball chain |
| ③ Gasket | ⑯ Nut | ㉒ Strainer cover gasket |
| ④ O-ring | ⑰ Clip | ㉓ Oil strainer |
| ⑤ Bolt | ⑱ Oil tank comp. | ㉔ Oil pipe |
| ⑥ Clip | ⑲ Clip | ㉕ Nipple |
| ⑦ Hose | ⑳ Bolt | ㉖ Pipe |
| ⑧ Check valve | ㉑ Collar | ㉗ Ignition coil damper |
| ⑨ Clamp | ㉒ Filter tube 1 | ㉘ Oil level gauge ass'y |
| ⑩ Drive gear | ㉓ Clamp | ㉙ Lead wire ass'y |
| ⑪ Driven gear | ㉔ Hook | ㉚ Lead wire |
| ⑫ Plate washer | ㉕ Oil tank cap ass'y | |
| ⑬ Distance collar | ㉖ Special washer 2 | |

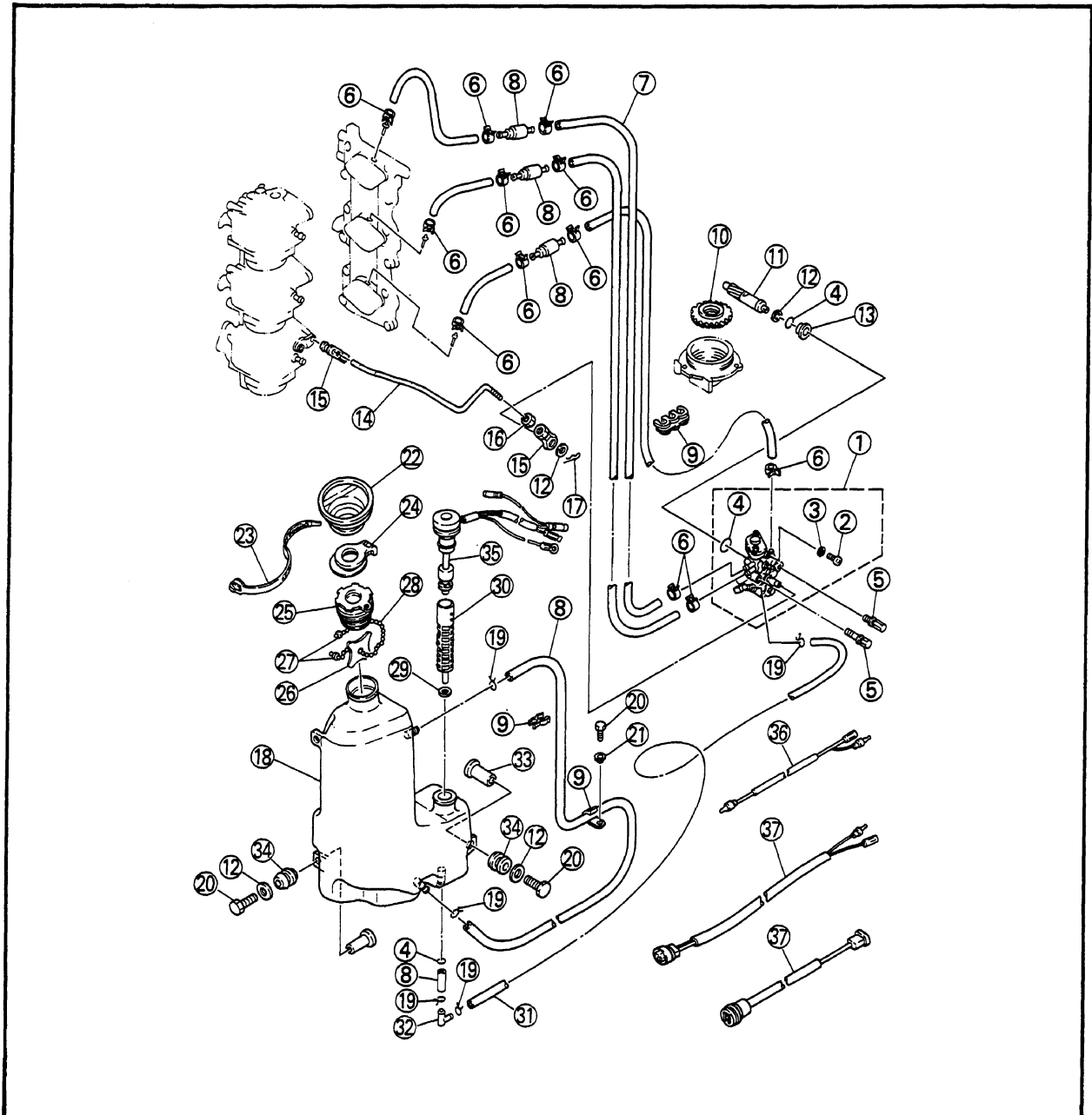



G62001-0*

PISTON

Cleaning

- 1) Using a gasket-scraper, remove the carbon from the piston top.
- 2) Using a broken ring, clean the ring grooves.

CAUTION:

The top ring is a keystone-type ring; therefore, do not use a broken top ring for cleaning the other ring grooves, nor use a broken ring from a lower groove for cleaning the top groove.

- 3) Using a soft brush and solvent, thoroughly clean the piston. If necessary, use 600 ~ 800 grit wet-or-dry sandpaper to remove score marks or varnish.

Inspection

- 1) Using a micrometer, measure the piston diameter at right angles to the piston-pin centreline, 10 mm (0.4 in) above the bottom edge.

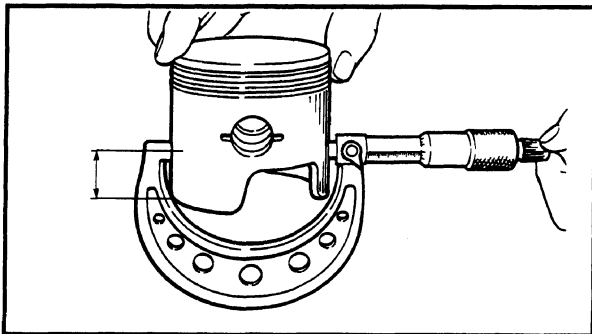

	Piston diameter:
	Standard:
	70 hp: 71.945 ~ 71.970 mm (2.8325 ~ 2.8335 in)
	90 hp: 81.935 ~ 81.960 mm (3.2258 ~ 3.2268 in)

- 2) Using the measured cylinder bore diameter in thrust directions, subtract the piston diameter measurement from the cylinder bore diameter measurement.

	Piston clearance:
	70 hp: 0.050 ~ 0.055 mm (0.0020 ~ 0.0022 in)
	90 hp: 0.060 ~ 0.065 mm (0.0024 ~ 0.0026 in)

If this clearance is greater than the maximum, replace the piston to standard or oversize, and/or rebore the cylinder.

Oversize piston:
70 hp: 1st: 72.50 mm (2.845 in)
90 hp: 1st: 82.50 mm (3.248 in)

CLICK HERE TO **DOWNLOAD** THE COMPLETE MANUAL

- Thank you very much for reading the preview of the manual.
- You can download the complete manual from: www.heydownloads.com by clicking the link below



- Please note: If there is no response to CLICKING the link, please download this PDF first and then click on it.

CLICK HERE TO **DOWNLOAD** THE COMPLETE MANUAL





G75000-0*

CYLINDER HEAD AND EXHAUST COVER

- 1) Install the gaskets, cylinder-head cover and exhaust cover.
- 2) Tighten the bolts in two sequences and in two steps of torque.

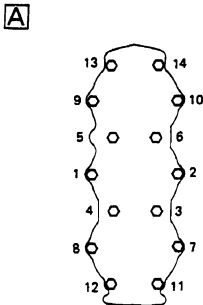
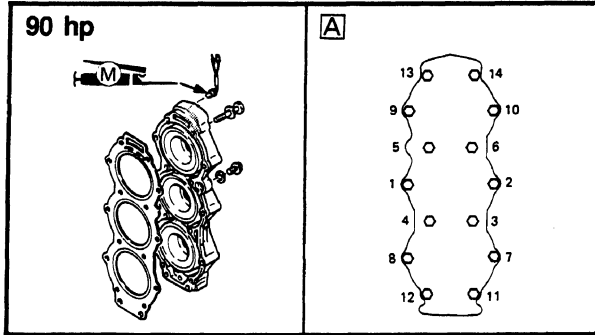
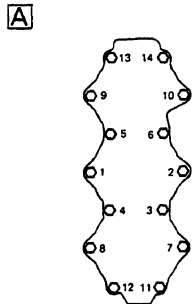
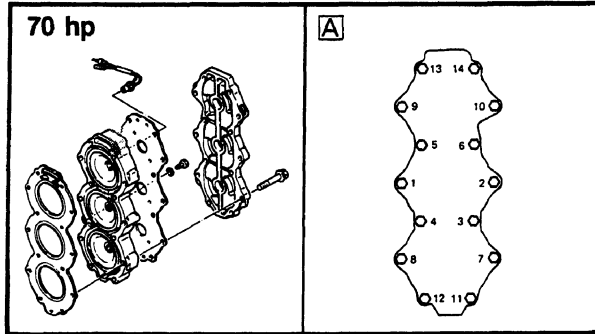
A Tightening sequence

Cylinder head:
1st step:
 15 Nm (1.5 m•kg, 11 ft•lb)
2nd step:
 30 Nm (3.0 m•kg, 22 ft•lb)

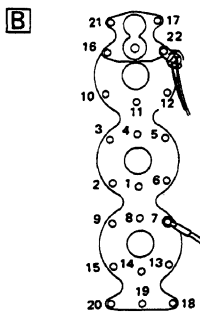
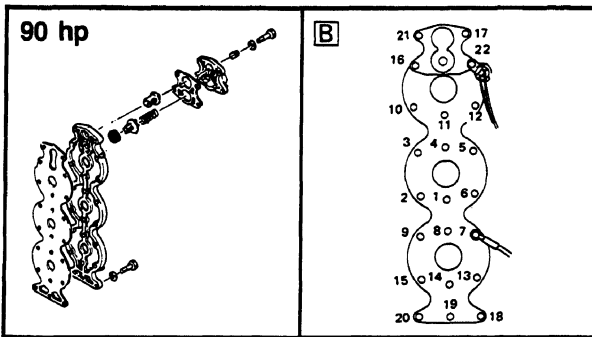

B Tightening sequence



Cylinder head cover (90 hp):
Thermostat cover:
 8 Nm (0.8 m•kg, 5.8 ft•lb)

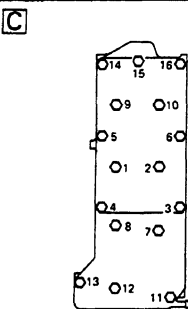
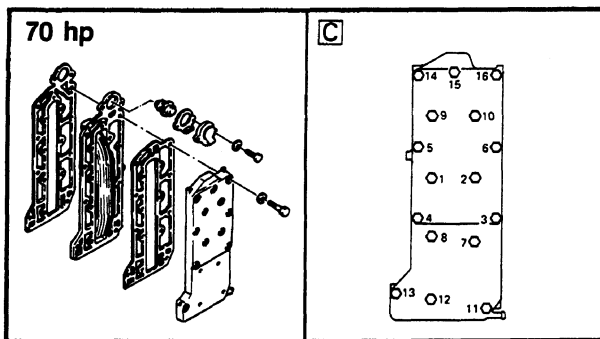

C Tightening sequence



Exhaust cover:
1st step:
 4 Nm (0.4 m•kg, 2.9 ft•lb)
2nd step:
 8 Nm (0.8 m•kg, 5.8 ft•lb)

- 3) Install the thermostat, gasket and cover.

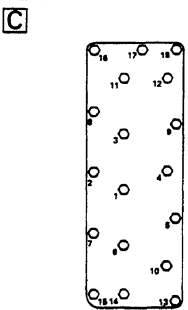
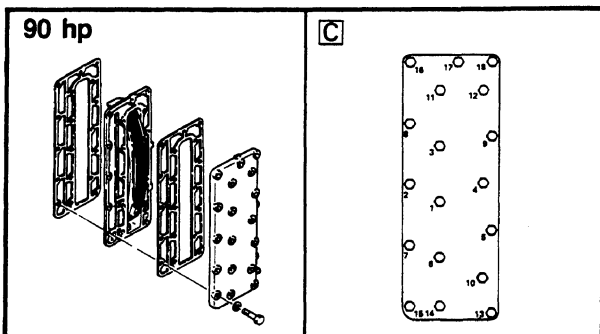

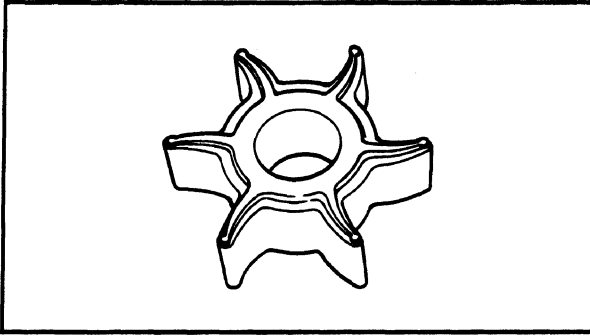

153500-0

IMPELLER

- 1) Visually inspect the impeller for cracks, distortion or burning. If any damage is found, replace the impeller.

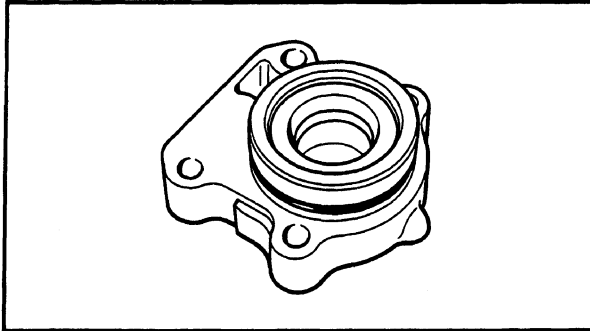

154000-0

OIL-SEAL HOUSING (Water pump housing 2)

- 1) Using a soft brush and solvent, clean the oil-seal housing.
- 2) Visually inspect the housing for cracks or corrosion. If a crack and/or excessive corrosion is found, replace the oil-seal housing.

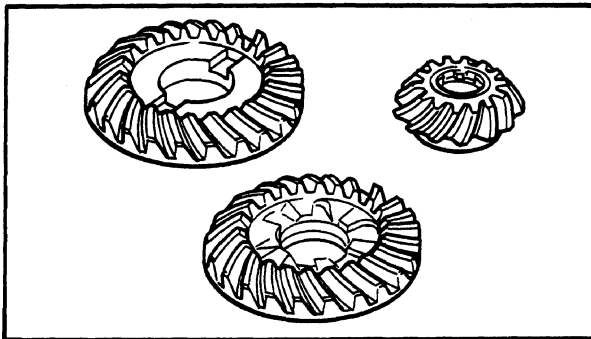

154500-0

GEARS

- 1) Visually inspect the teeth and dogs on the gears for cracks, peeling or distortion due to gear-crashing. If damage is found on any of the gears, replace with new one.

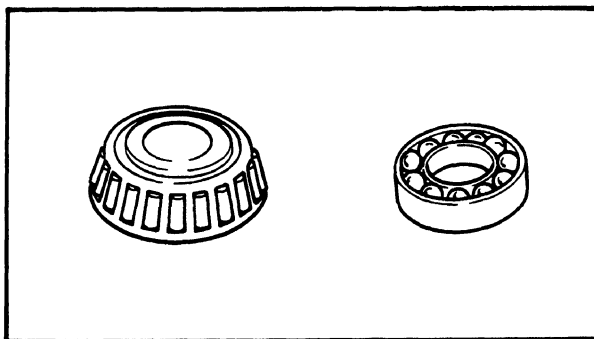

155000-0

BEARINGS

- 1) Inspect the bearings for pitting, scratching or rumbling (which may be detected by turning the bearing by hand), and replace them if they are not in good condition.

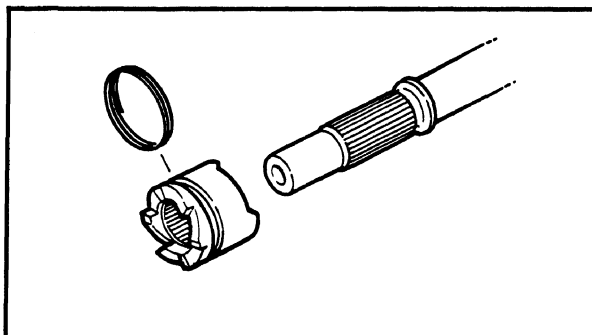

155500-0

CLUTCH DOG AND COMPONENTS

- 1) Visually inspect the clutch dog, looking particularly for rounding of the dog edge, cracks and other signs of damage or wear. If the dog is excessively rounded, inspect also the mating gear, and replace both if necessary.

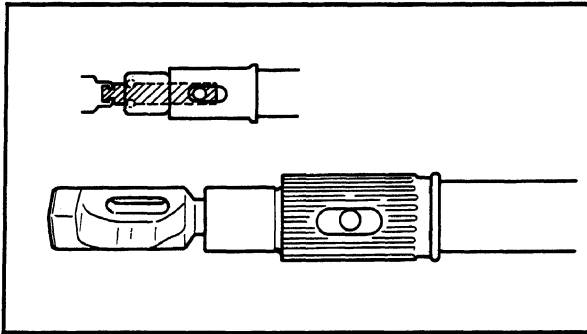

5. Install the clutch dog so that its cross pin hole is aligned with the slot in the splined portion of the propeller shaft.

NOTE: _____
 Install the clutch dog so that the "F" mark on the clutch dog is on the forward gear side.

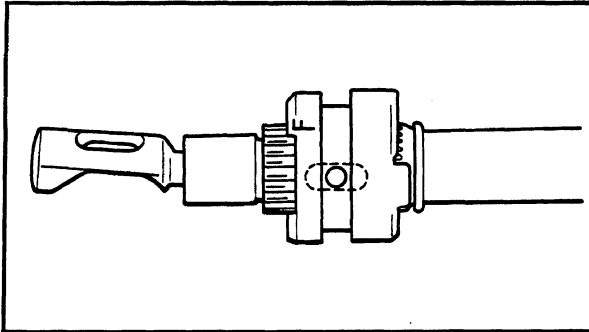

6. Bring the cross pin hole in the clutch dog with the hole in the shift slide, and insert the cross pin into these holes, then install the cross pin ring.

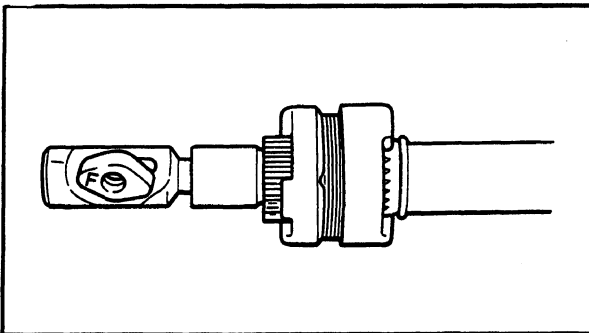

7. Place the shift cam on the shifter, with the "F" mark on the shift cam facing forward, and insert the propeller shaft into the forward gear.

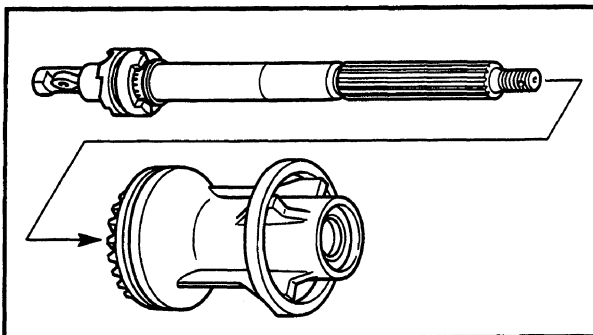

8) Grease the lips of the oil-seals, and insert the propeller shaft complete into the bearing housing.

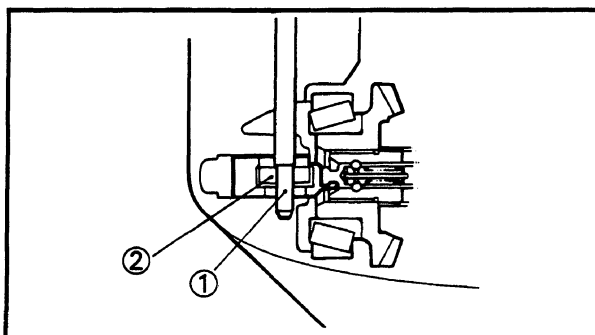

9) Look into the gear case through the hole, and align the shift rod hole in the gear case with the splined hole in the shift cam, and install the shift rod.

- ① Shift rod
- ② Shift cam

K15000-0

EXPLODED DIAGRAM

UPPER CASING

70 hp

- ① Exhaust guide
- ② Exhaust manifold
- ③ Muffler
- ④ Upper case
- ⑤ Apron
- ⑥ Seal
- ⑦ Bottom cowling

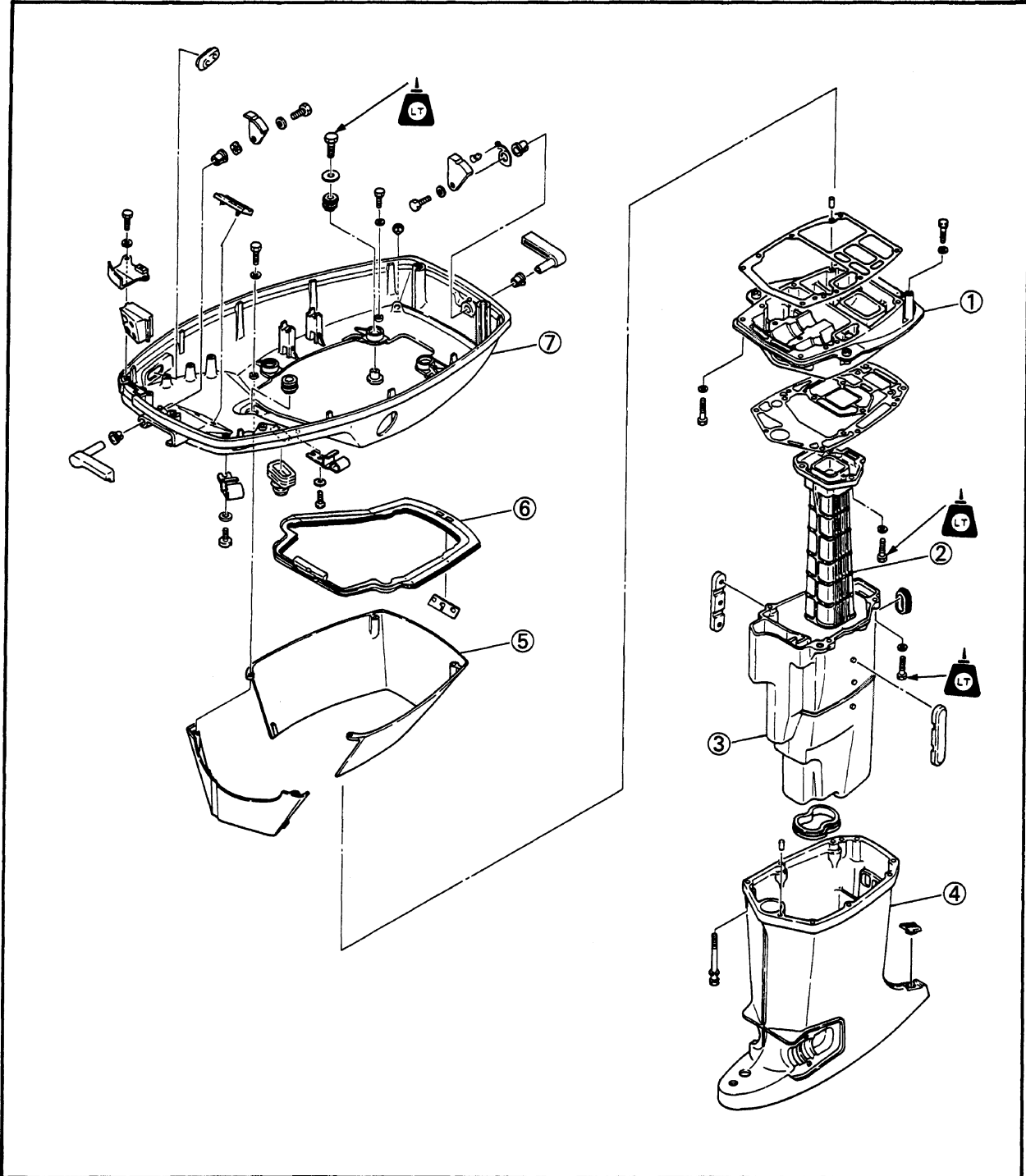



K54000-0*

ASSEMBLY**NOTE:**

The components in this assembly are to be lightly coated with hydraulic fluid before assembly.

- 1) Install the manual-valve to the body with new O-rings.

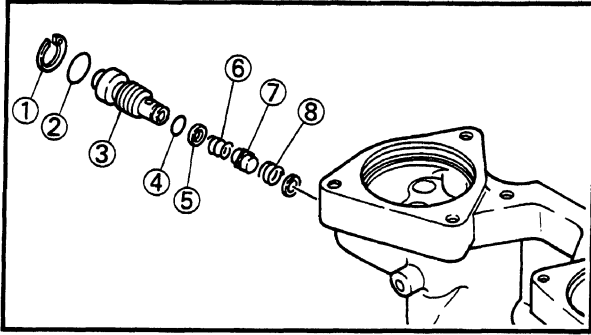

- ① Snap ring
- ② O-ring
- ③ Manual release screw
- ④ O-ring
- ⑤ Manual valve seat
- ⑥ Manual release spring 1
- ⑦ Adapter 1
- ⑧ Manual release spring 2

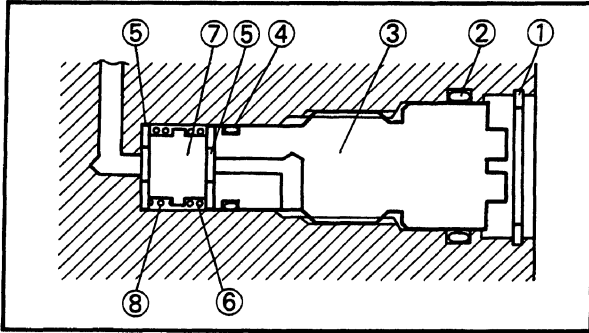

- 2) Install new O-ring on the shuttle-piston, and insert the piston into the body; then install the main valves with new O-rings.

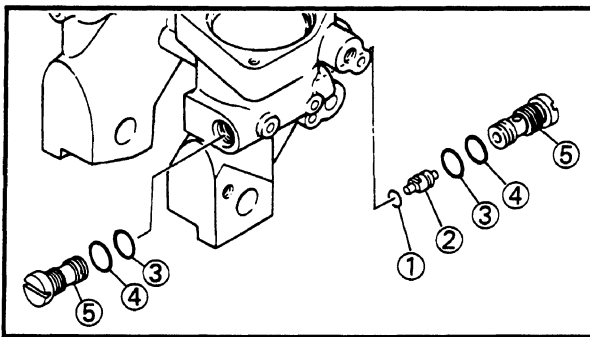

- ① O-ring
- ② Shuttle-piston
- ③ O-ring
- ④ O-ring
- ⑤ Main valve

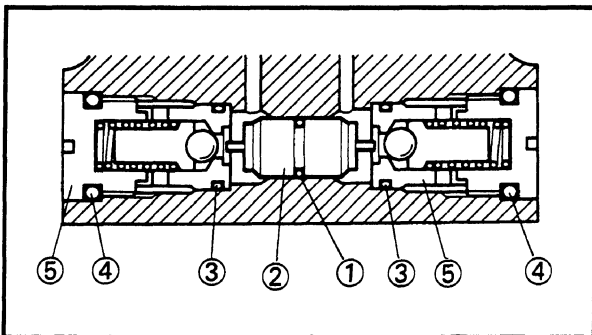



M51800-0*

CHARGE COIL

Check the resistance of the charge coil.

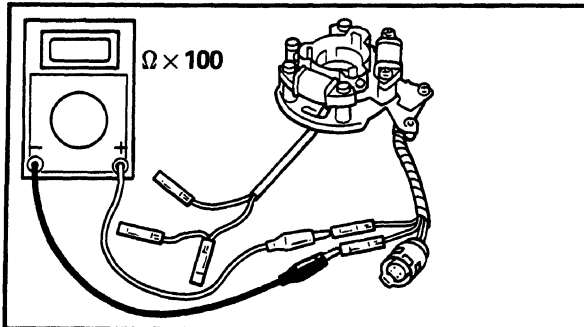
**Charge coil resistance:****Brown—Black:** $165\Omega \pm 10\%$

at 20 deg.C (68 deg.F)

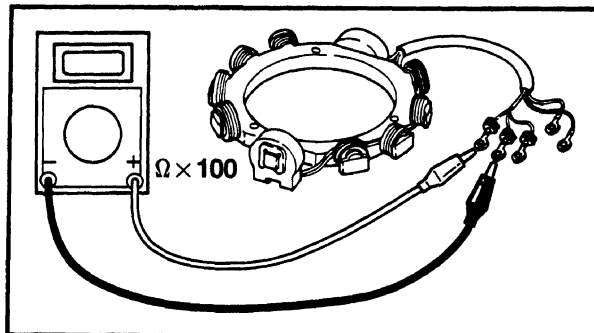
**Charge coil resistance:****Brown—Blue:** $850\Omega \pm 10\%$

at 20 deg.C (68 deg.F)

Blue—Red: $120\Omega \pm 10\%$

at 20 deg.C (68 deg.F)

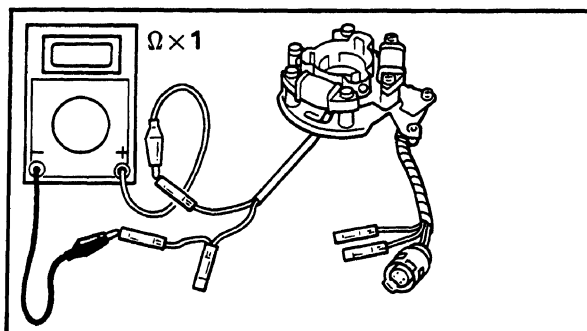

M52000-0*

LIGHTING COIL

1) Check the resistance of the lighting coil.

70 hp

**Lighting coil resistance:****Green—Green:****Standard (12V, 80W):** $0.45\Omega \pm 20\%$ at 20 deg.C

(68 deg.F).

90 hp

**Lighting coil resistance:****Green—White:****Standard (12V, 120W):** $0.6\Omega \pm 10\%$ at 20 deg.C

(68 deg.F).

① Green

M56501-0

RECTIFIER

1) Check the continuity of the rectifier.

70 hp

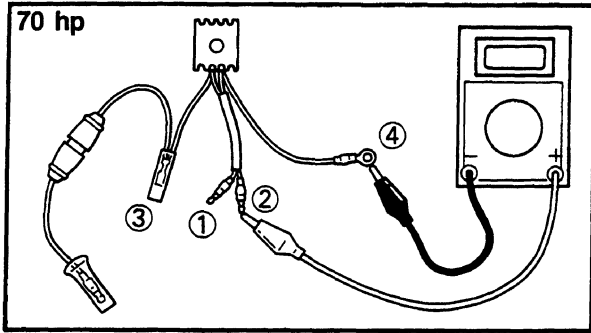

Tester + Tester	① Green 1	② Green 2	③ Red	④ Black
① Green 1		∞	Continuity	∞
② Green 2	∞		Continuity	∞
③ Red	∞	∞		∞
④ Black	Continuity	Continuity	Continuity	

∞: No continuity

90 hp

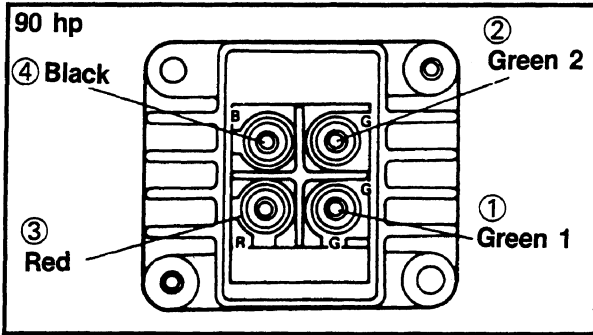

Tester + Tester	① Green 1	② Green 2	③ Red	④ Black
① Green 1		∞	Continuity	∞
② Green 2	Continuity		Continuity	Continuity
③ Red	∞	∞		∞
④ Black	Continuity	Continuity	Continuity	

∞: No continuity

If continuity is not as specified, replace the rectifier.

NOTE:

1. Never connect the rectifier directly to the battery to check continuity.
2. When testing, disconnect the battery terminals.
3. When resistance is measured at less than 100Ω, it can be said that there is continuity.

M57001-0*

FUSE

- 1) Referring to the diagram, check the continuity of the fuse. If the fuse is blown, replace with a fuse of correct rating.

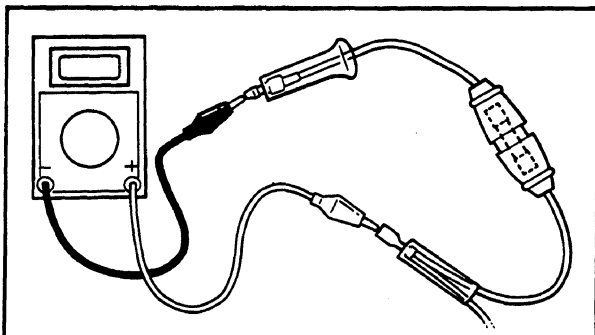

Fuse rating: 70 hp	10A
90 hp	20A

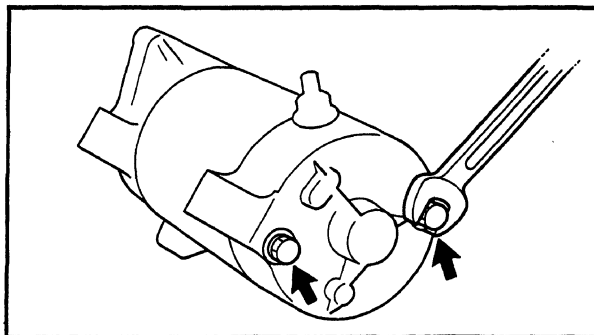
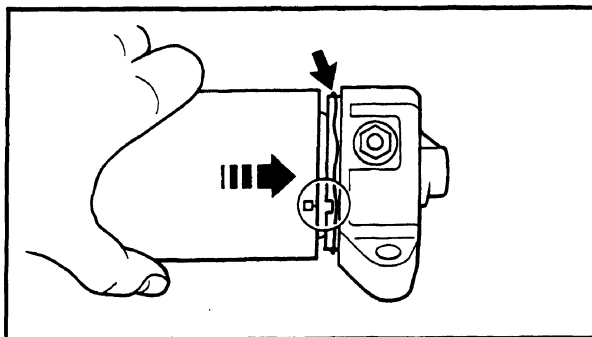
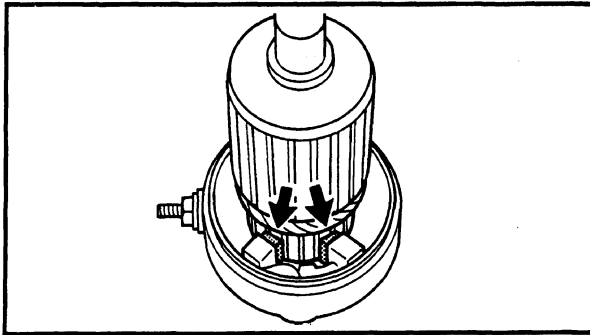
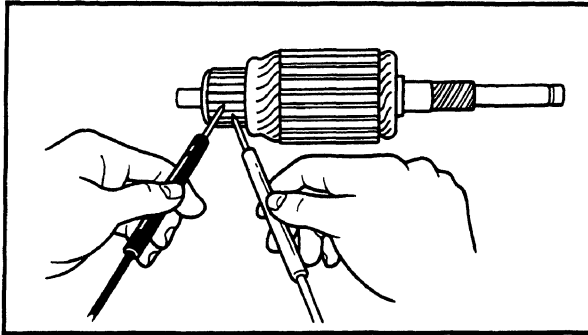
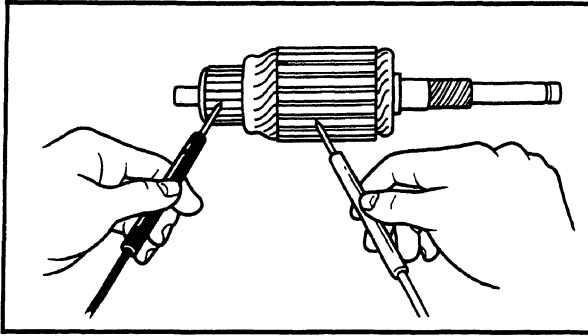

Armature

- 1) Test to check that the commutator is not earthed to the shaft or laminations, and if such continuity is found, replace the armature.
- 2) Inspect the commutation for open circuit by checking for continuity between segments. If any segment is not in continuity, replace the armature.

ASSEMBLY (70 hp)

1. Apply a thin coat of Yamaha Marine Grease to the rear cover bushing, and install the armature in the rear cover assembly.

NOTE:

The method is to lift the brushes, and insert the armature straight into the bushing taking care not to scratch the brush or contaminate it with grease.

2. Assemble the stator, aligning the recess on the rear cover with the projection on the stator, and ensuring that the O-ring fits correctly in the rear cover groove.

3. Mount the two washers on the armature shaft. Sparingly apply Yamaha Marine Grease to the front cover bushing, ensure that the O-ring fits to the armature shaft, and insert the shaft into the front cover.

ENGINE WILL NOT START

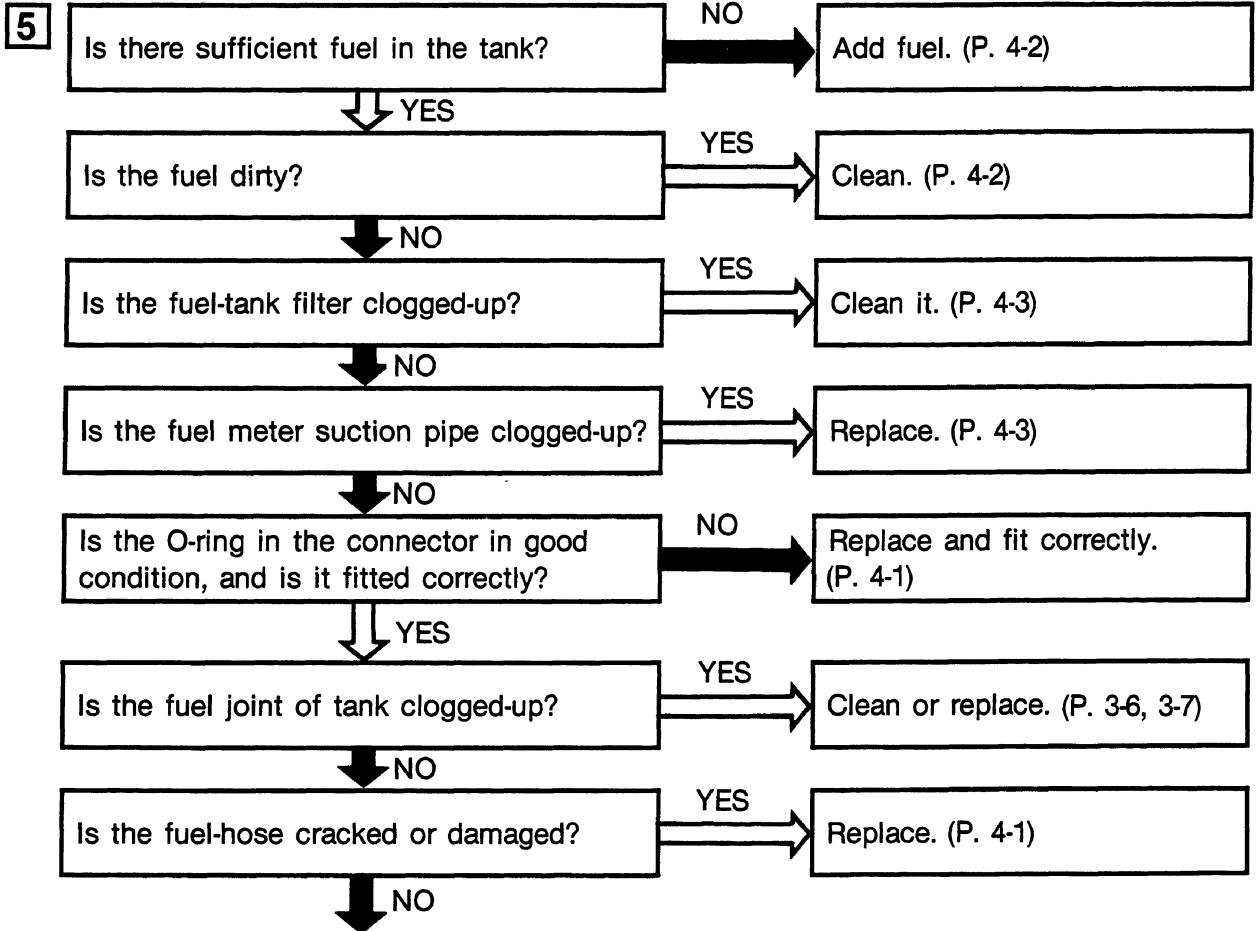
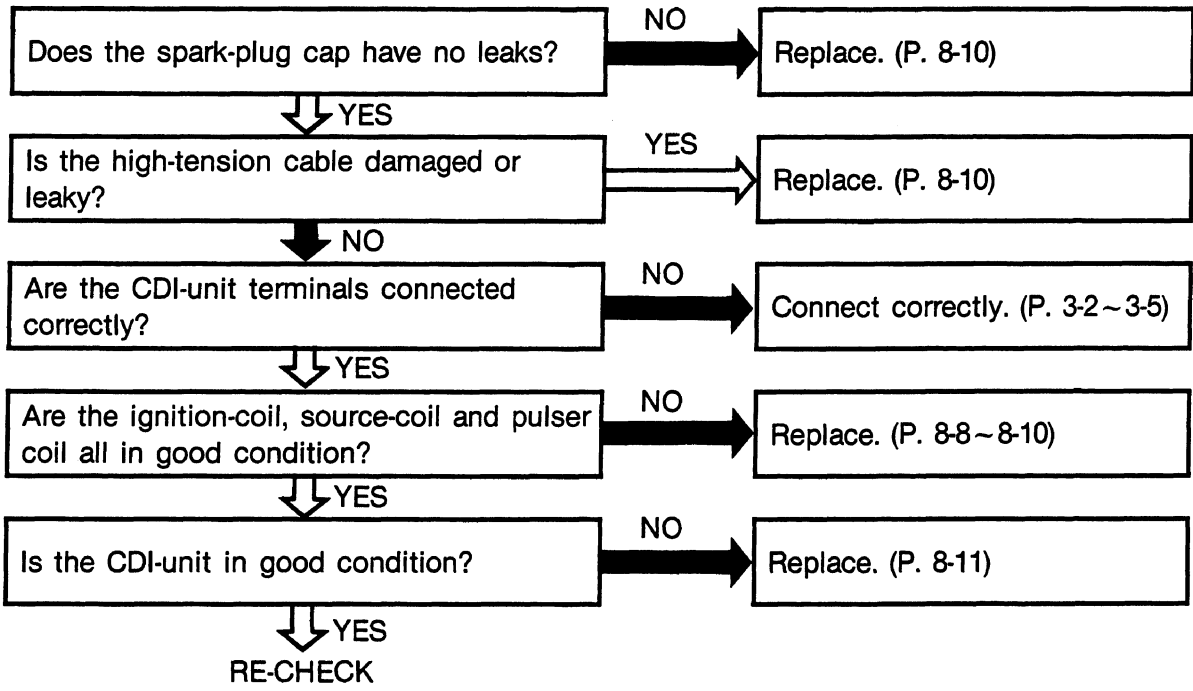

CLICK HERE TO **DOWNLOAD** THE COMPLETE MANUAL

- Thank you very much for reading the preview of the manual.
- You can download the complete manual from: www.heydownloads.com by clicking the link below



- Please note: If there is no response to CLICKING the link, please download this PDF first and then click on it.

CLICK HERE TO **DOWNLOAD** THE COMPLETE MANUAL