

CUSHMAN
A Textron Company

36117G01

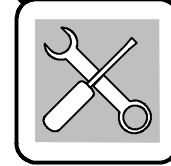

SERVICE & REPAIR INSTRUCTION MANUAL

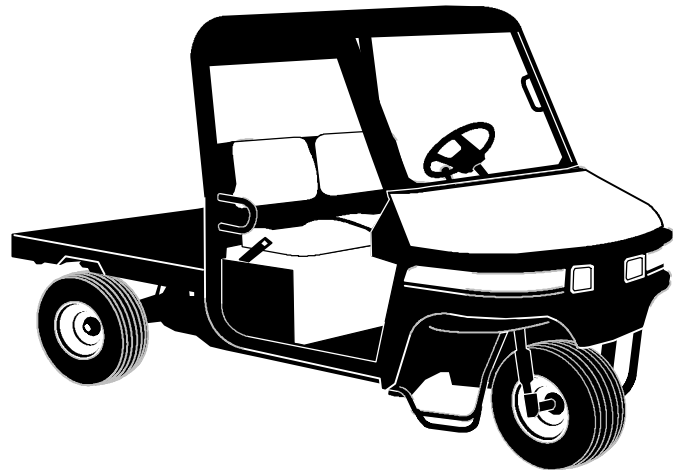
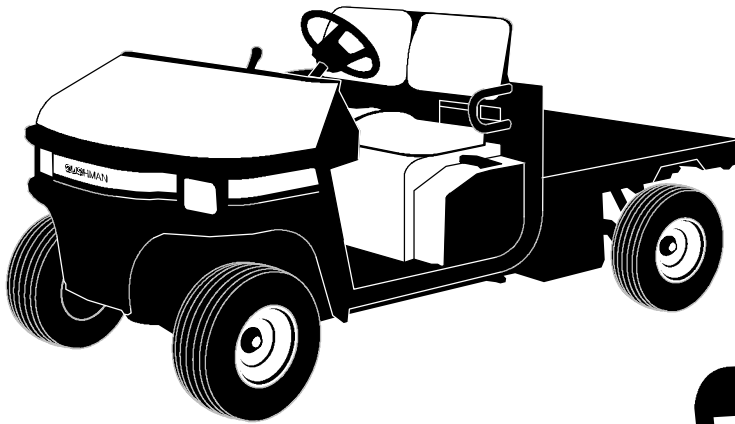

HAULSTERS[®]

CLICK HERE TO **DOWNLOAD** THE COMPLETE MANUAL

- Thank you very much for reading the preview of the manual.
- You can download the complete manual from: www.heydownloads.com by clicking the link below



- Please note: If there is no response to CLICKING the link, please download this PDF first and then click on it.

CLICK HERE TO **DOWNLOAD** THE COMPLETE MANUAL

SECTION 1A. GENERAL INFORMATION

1A

JACKS, JACKING LOCATIONS AND USING A HOIST

A scissors type jack or a floor jack with a 1-1/2 ton (minimum) capacity that can be lowered to 3-3/8 inches (86 mm) height is required.

The jacking locations are shown in Figure 1A-3.

Put the gear selector in 1st gear. Apply the park brake. Raise the vehicle only enough to perform maintenance required.

Place a jack in the appropriate location (see Figure 1A-3) and place a block behind (or in front) of the tire diagonally opposite the side which is being raised (see Figure 1A-4).

Jack the vehicle to the appropriate height and place jack stands or equivalent support beneath the frame near the jack. Lower the jack and allow the vehicle to rest on the jack stands. Raise the vehicle only enough to perform the maintenance required.

Make sure to block the tire diagonally opposite of the side which is being raised (see Figures 1A-4 and 1A-5).

When using a hoist to raise the vehicle, use the same procedure for supporting the frame and blocking the tires as you would when using a jack.

! WARNING

Do not rely solely on hydraulic or mechanical jacks for support. Use appropriate jack stands or equivalent for supporting the vehicle. If using a hoist, raise vehicle to appropriate height and support using jack stands or equivalent support.

Never place feet, hands or any part of your body under the vehicle when raising it with a hoist.

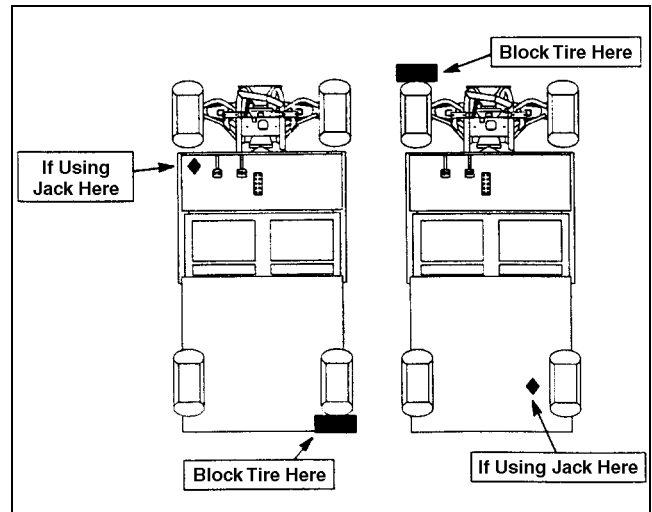

Figure 1A-4. Blocking

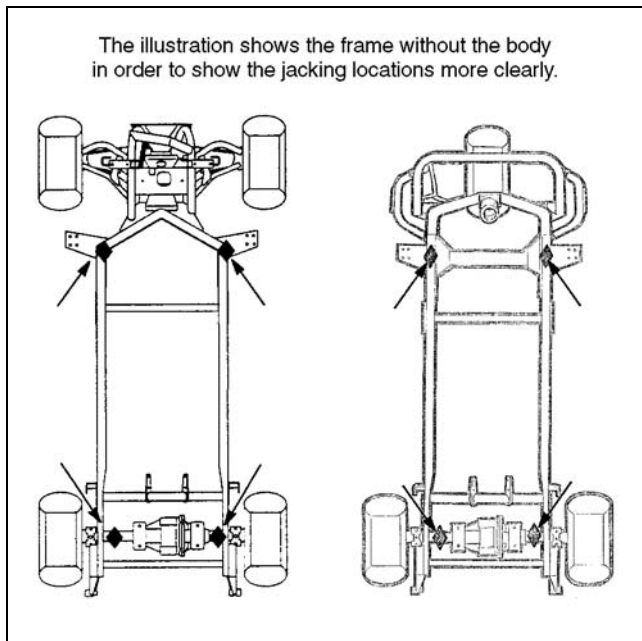

Figure 1A-3. Jacking Locations

! CAUTION

To prevent damage to the vehicle or attached accessory, never use a hoist to raise only one corner of the vehicle. Always raise both front or rear corners equally.

SECTION 2C. CONTROL ADJUSTMENTS

2C

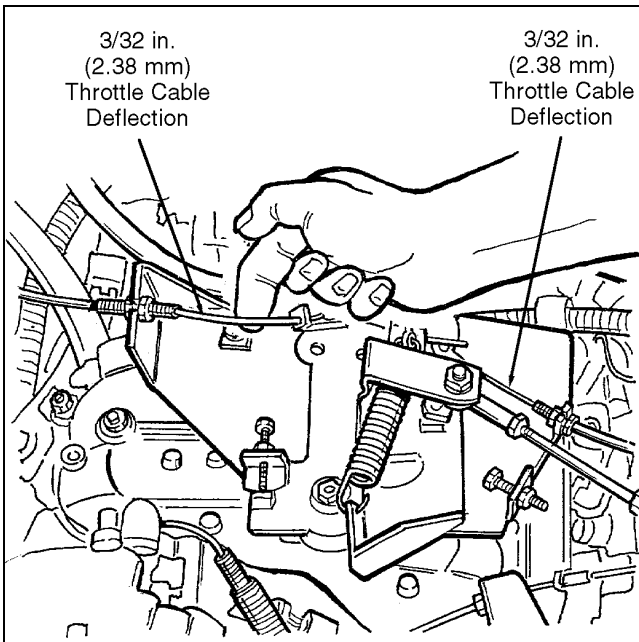

Figure 2C-13. Throttle Cable Adjustment

- Remove the cotter pin and clevis pin securing yoke and rod to black governor arm (see Figure 2C-14). Pull the yellow plated governor arm back to the end of travel and hold while adjusting rod so that edge of black governor arm is parallel with the sides of the governor housing. Secure yoke to governor arm with clevis pin only. This is a critical adjustment, make sure you pull the yellow arm back when adjusting the rod. If the rod is too short, correct setting of the high RPM will be affected.

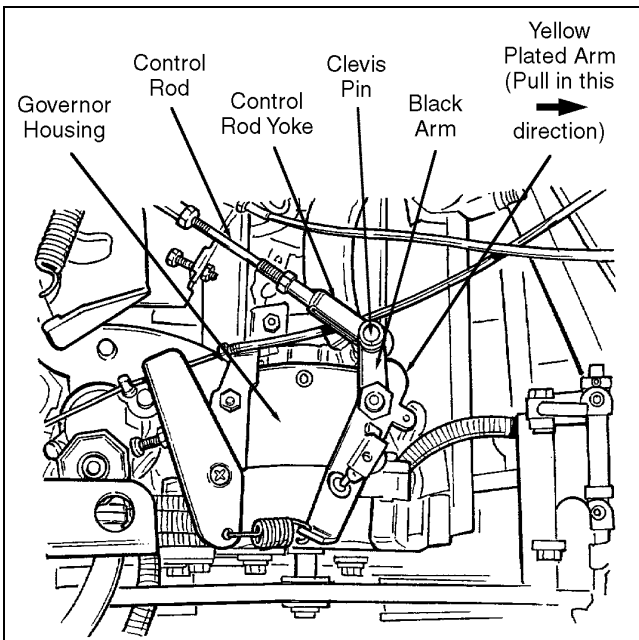

Figure 2C-14. Governor Arm Adjustment

- Position the shift lever to neutral (N) and make certain the parking brake is applied. Start the engine, allow it to warm up with the hand throttle lever in the 'DOWN' (turtle icon) position and the hand throttle lever in the 'UP' (rabbit icon) position.
- Loosen the stop nut on the governor cable (see Figure 2C-15). Move the governor linkage arm by hand until 2500 ± 50 RPM is obtained, then tighten the stop nut.

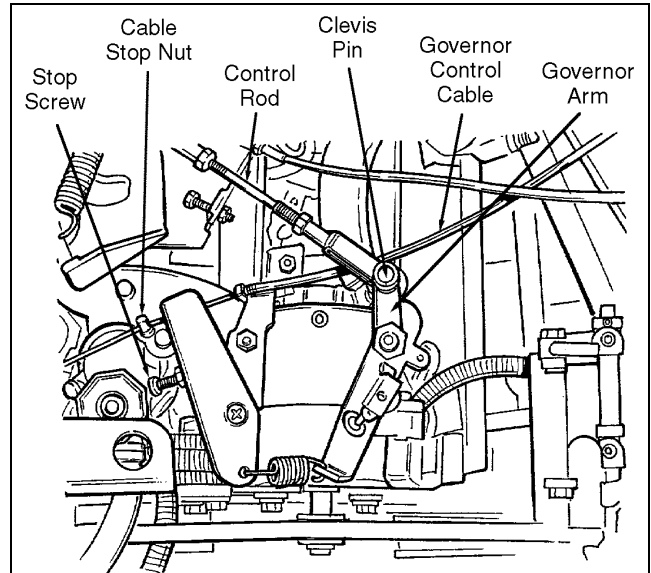

Figure 2C-15. RPM Adjustments

- Move the handle throttle lever to 'UP' (rabbit icon) position and move the governor control lever 'UP' or 'DOWN' until 3600 ± 50 RPM is obtained. Tighten the governor stop screw (see Figure 2C-15) to lock the high RPM setting.
- Push the hand throttle lever to the full 'UP' position, the engine RPM may briefly exceed the adjusted high speed (3600 ± 50 RPM) but should return to that speed almost immediately.
- If governor hunts during throttle up test, in Step 8 above, remove the clevis pin and adjust governor rod shorter, 1/2 turn at a time (the rod is too long) until the governor stops hunting during the test. The RPM should not be significantly affected. If the RPM increases when making this adjustment the rod is already too short and the adjustment procedure in Step 4 above should be repeated. Install the clevis pin and cotter pin after readjusting.

SECTION 3A. REPAIR AND SERVICE TOOLS AND MATERIALS

Tools required: Standard automotive hand tools.

Cleaning materials: Stoddard or equivalent solvent.
Detergent and water.
Anti-rust Never-Seize.

Lubricants: Refer to SECTION 11.

Other service items: Compressed air source.
Engine hoist.
Oil filter.
Fuel filter.
Air cleaner element.
Fan belt.
Loctite[®] 592.

3A

SECTION 3E. GASOLINE ENGINES

GENERAL

The gasoline engine used in your vehicle is a 3-cylinder Suzuki 660 with either a conventional or electronic fuel injected (EFI) system. An engine service manual for both engines is available from your dealer.

SPARK PLUG WIRES

1. Remove high tension coil cable at ignition coil while gripping its cap.

**CAUTION**

Removal of spark plug wires together with clamps is recommended so as not to damage their inside wire. For the same reason, pull out each connection by gripping at the cap.

2. Remove distributor cap with spark plug wires installed.
3. Remove high tension cable clamp from cylinder head cover.
4. Pull out spark plug wire from each spark plug while gripping its cap.
5. Use an ohmmeter to measure spark plug wire resistance. Resistance should be 3 ñ 6.7 k/ft. (10 to 22 k/m).
6. If resistance is outside of specified reading, inspect and replace the distributor cap and/or spark plug wires as required.

**CAUTION**

Never use metal conductor high tension wires as replacement parts. Insert each cap portion fully when installing spark plug wires.

SPARK PLUGS

1. Pull out spark plug wires by gripping their caps and then remove the spark plugs.
2. Inspect for electrode wear, carbon deposits and insulator damage.
3. If any problem is found, adjust spark plug air gap, clean with spark plug cleaner or replace them with specified new plugs.
4. Gap spark plugs to 0.032 to 0.035 inch (0.8 to 0.9 mm).
5. Torque spark plugs to 18.5 to 21.5 ft-lbs. (25 to 30 N.m).
6. Install spark plug wires securely by gripping their caps.

3E

IGNITION SYSTEM (CONVENTIONAL)

The basic components of this ignition system are ignition coil, distributor and spark plugs. The components of the distributor are signal generator (signal rotor and pickup coil), igniter, rotor, cap and both vacuum and centrifugal advance.

When the distributor shaft rotates, the magnetic flux passing through the pickup coil varies due to the change in air gap between the pickup coil and the signal rotor. As a result, the alternating current voltage is induced in the pickup coil.

The voltage induced, turns on and off the igniter which switched off the ignition coil primary current. Thus, the high voltage is induced in the secondary winding of ignition coil and ignition sparks are generated at the spark plugs.

The spark advance is produced by the vacuum advancer which operates based on the engine vacuum and centrifugal advancer.

IGNITION COIL TEST (See Figure 3E-1)

Measure resistances of primary and secondary windings of the ignition coil at 68°F (20°C). If resistance is out of specification replace coil with a new one.

Primary Winding Resistance	1.08 to 1.32 Ω (Ohms)
Secondary Winding Resistance	22.1 to 29.2 Ω (Ohms)

SECTION 3E. GASOLINE ENGINES

ENGINE INSTALLATION

1. Using a suitable lifting device, lift engine and position in-line with transmission.
2. Push engine toward transmission so drive shaft splines of transmission engage clutch. It may be necessary to rotate transmission gearing to index clutch disc splines.
3. Fasten engine to bell housing.
4. Install engine mounting hardware.
5. Reconnect clutch cable to clutch arm and reconnect return spring. To adjust see SECTION 2C.
6. Install drive shaft.
7. Reconnect accelerator and governor cables. See SECTION 2C for adjustments.
8. Reconnect exhaust pipe.
9. Reconnect intake and return fuel lines.
10. Reconnect electrical wiring.

3E

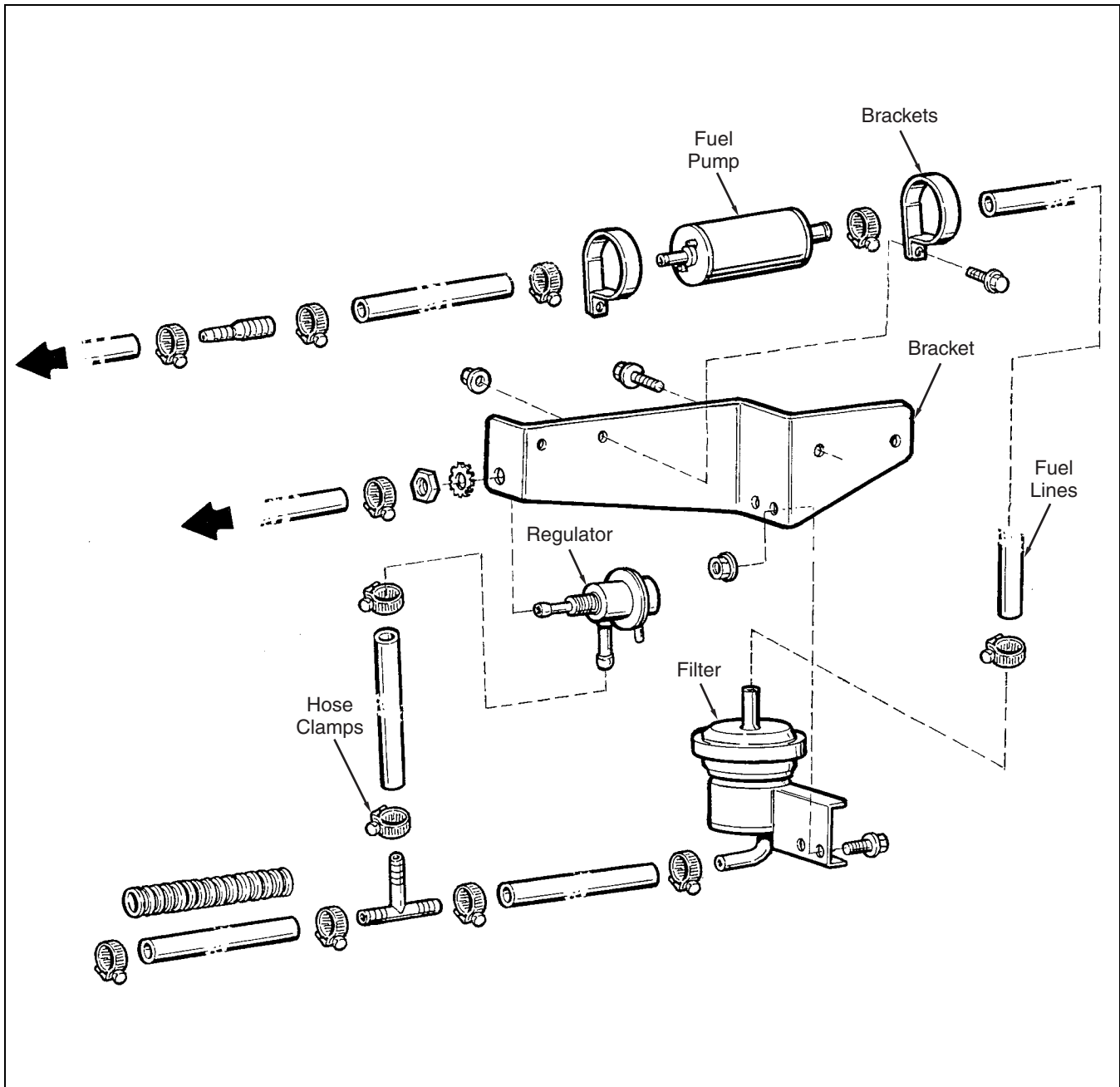

Figure 3E-9. EFI Fuel System

SECTION 4B. FAILURE ANALYSIS

PROBLEM	PROBABLE CAUSE	REMEDY
1. Noisy when vehicle moving forward or reverse.	<ul style="list-style-type: none"> a. Excessive gear backlash. b. Faulty U-joints. 	<ul style="list-style-type: none"> a. Adjust (Section 4G or 4H). b. Repair (Section 4C).
2. Clunking sound when changing direction.	<ul style="list-style-type: none"> a. Axle drive U-joint faulty. b. Excessive differential gear backlash. 	<ul style="list-style-type: none"> a. Repair (Section 4C). b. Adjust (Section 4I).
3. Control lever moves but will not shift.	<ul style="list-style-type: none"> a. Control lever assembly broken or damaged. b. Damaged offset lever, shift fork, selector plate or selector arm. 	<ul style="list-style-type: none"> a. Replace control lever or housing assembly (Section 4G or 4H). b. Remove shifter case cover. Check for damaged parts. Replace damaged parts (Section 4G).
4. Hard shift or control lever will not move into gear.	<ul style="list-style-type: none"> a. Clutch not releasing. b. Improper or low transmission lubricant. c. Shifter shaft or shift rail binding. d. Binding of sliding synchronizer or gears. e. Reverse only, seized backup switch. 	<ul style="list-style-type: none"> a. Adjust or replace clutch (Section 4D). b. Add or drain and replace with proper lubricant (Section 11). c. Remove shifter case cover. Check for damaged parts. Replace damaged parts (Section 4G or 4H). d. Remove shifter case cover. Check that synchronizers and gears (parts with shifting grooves) slide freely on shafts. Remove and replace damaged parts (Section 4G or 4H). e. Remove and check backup switch. Replace if seized (Section 10).
5. Slipping clutch.	<ul style="list-style-type: none"> a. Loss of clearance at the tip of release fork. b. Clutch facings dirty with oil or excessively worn. c. Weakened diaphragm spring. d. Distorted pressure plate or fly-wheel surface. e. Improper clutch pedal free travel. 	<ul style="list-style-type: none"> a. Adjust (Section 4D). b. Replace (Section 4D). c. Replace (Section 4D). d. Replace (Section 4D). e. Adjust and/or replace clutch facings (Section 4D).
6. Dragging clutch.	<ul style="list-style-type: none"> a. Improper clutch pedal free travel. b. Weakened diaphragm spring or worn spring tip. c. Damaged or worn splines of transmission input shaft. d. Front input shaft bearing worn or broken. e. Excessively wobbly clutch disc. f. Clutch facings broken or dirty with oil. 	<ul style="list-style-type: none"> a. Adjust free travel (Section 4D). b. Replace (Section 4D). c. Replace (Section 4G or 4H). d. Replace (Section 4G or 4H). e. Replace (Section 4D). f. Replace (Section 4D).

4B

SECTION 4D. CLUTCH

3. After installing release shaft/fork bushings, caulk transmission case against bushings at two points.
4. Position the return spring (see Figure 4D-3) on the clutch release shaft/fork.
5. Install the clutch release shaft/fork in the bushings. Install the clutch release lever on the shaft/fork as shown in Figure 4D-8, aligning the two punch marks on the release arm with the shaft/fork.

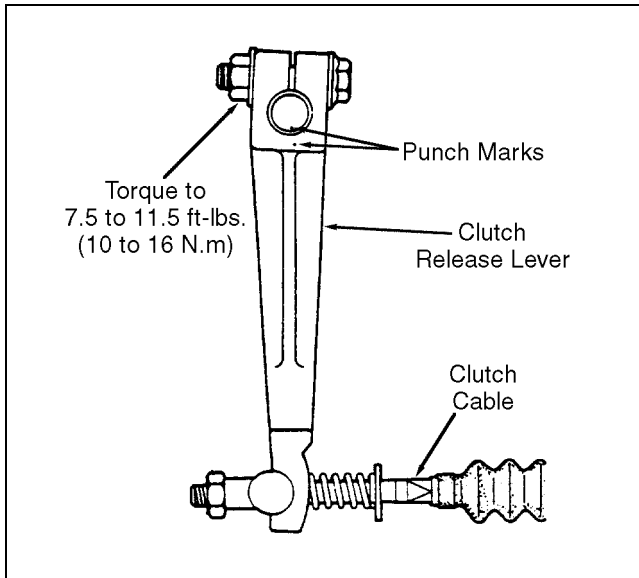

Figure 4D-8. Clutch Release Lever Installation

6. Hook the return spring (Figure 4D-3) onto the clutch release lever.
7. Install the clutch release bearing on the transmission input shaft retainer.
8. Refer to Figure 4D-9, use a flywheel holder tool to hold the engine flywheel. Use a clutch center guide tool to install the disc and clutch cover to the flywheel. Secure with six cover bolts. Torque bolts to 13.5 to 20 ft-lbs. (18 to 25 N.m). Remove the center guide tool.

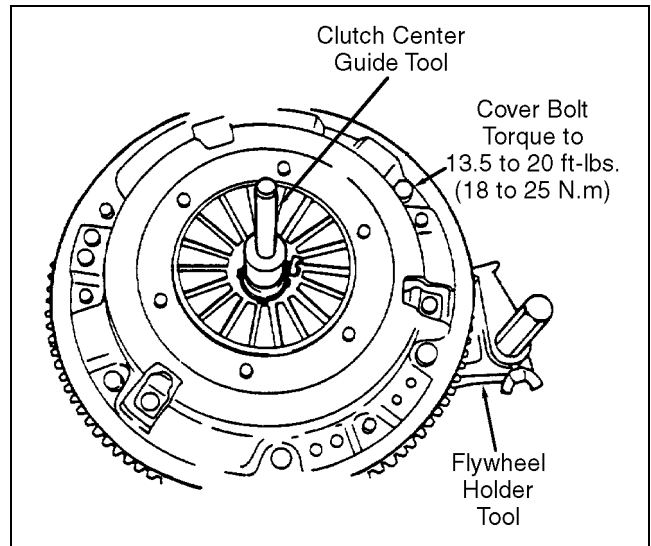

Figure 4D-9. Clutch Cover and Disc Installation

CLUTCH ADJUSTMENTS

After repair of the clutch and/or removal of the engine or transmission, adjust clutch pedal free travel, clutch cable and interlock switch as described in SECTION 2C.

CLICK HERE TO **DOWNLOAD** THE COMPLETE MANUAL

- Thank you very much for reading the preview of the manual.
- You can download the complete manual from: www.heydownloads.com by clicking the link below



- Please note: If there is no response to CLICKING the link, please download this PDF first and then click on it.

CLICK HERE TO **DOWNLOAD** THE COMPLETE MANUAL

SECTION 4G. 4-SPEED TRANSMISSION

GENERAL

The transmission is a 4-speed manual shift type. The shift pattern is a standard H pattern with reverse R over to the right and down.

In some cases the entire transmission may not have to be disassembled. Disassemble only what is needed for repair.

TRANSMISSION REMOVAL

1. Disconnect the negative (n̄) and positive (+) battery cables from battery terminals.
2. Tag and disconnect all cables, hoses, tubes or control linkages which would obstruct lifting the transmission out of the frame.
3. Remove any sheet metal which would obstruct lifting the transmission out of the frame.
4. Remove the drain plug and drain oil from the transmission. Replace drain plug and torque to 14.5 to 21.5 ft-lbs. (20 to 30 N.m) for units with 3-cylinder gasoline engines and 26.5 to 36.0 ft-lbs. (36 to 50 N.m) for units with 4-cylinder gasoline or diesel engines.
5. Disconnect the clutch cable from the clutch release lever.
6. Disconnect the shift cables (see SECTION 4E).
7. Disconnect the drive shaft at the transmission (see SECTION 4C).

8. Attach a suitable hoist to the transmission.
9. Remove hardware that fastens the transmission to the engine.
10. Remove any remaining transmission hardware from mounting brackets on the frame until the transmission is free to be lifted.
11. Carefully move the transmission away from the engine flywheel and move the transmission out of the frame to a suitable work stand.

INPUT SHAFT BEARING REPLACEMENT

NOTE

Whenever the engine and transmission are separated, the transmission input shaft bearing mounted in the engine flywheel should be inspected for wear or damage.

1. Turn the bearing by hand, if it sticks, rattles or makes abnormal noise when spun, it should be replaced.
2. Remove the input shaft bearing using a removal tool as shown in Figure 4G-1.
3. Install a new bearing as shown in Figure 4G-1.
4. Visually check the flywheel surface, where it contacts the clutch disc, for wear or damage. If wear or damage is determined, replace the flywheel in accordance with engine manufacturer's instructions.

4G

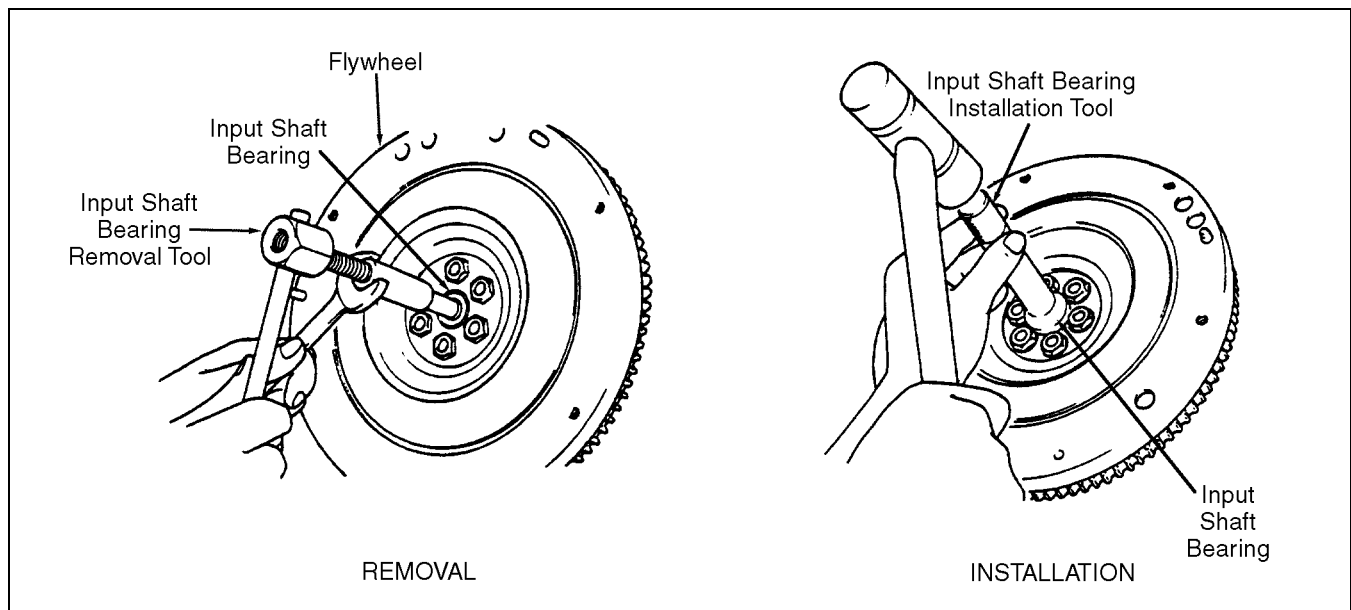

Figure 4G-1. Input Shaft Bearing Replacement

SECTION 4G. 4-SPEED TRANSMISSION

Since the ring is unable to slide along any further, the sleeve lets go of the keys and rides over to the ring. At this moment, the initial contact between the chamfered ends of teeth of the ring and those of internal teeth of the sleeve occurs. This contact is such that the internal teeth of the sleeve align themselves to those of the ring. When the sleeve advances and slides into the ring, the ring will be rotating nearly with the speed of the gear, so that the sleeve can smoothly slide over into the clutch teeth of the gear.

The initial contactor mesh between sleeve and ring is determined by the widths of key and slot. The key clearance in the slot should extend at least a third (1/3) of the chamfer (see Figure 4G-16).

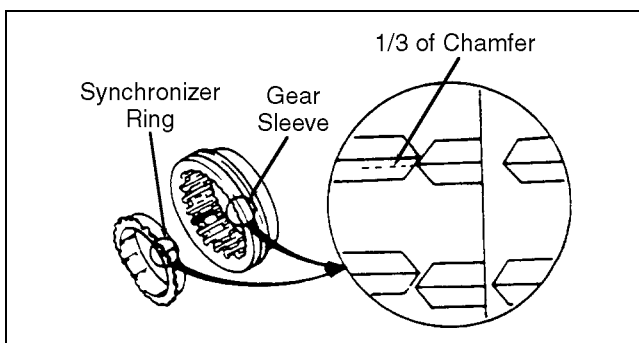

Figure 4G-16. Checking Key Clearance

With the synchronizer properly assembled on the shaft, push in and twist each synchronizer to see if the one-third mesh occurs or not; if not, it means that the overall wear (which is the sum of the wears of slots, keys and chamfered tooth ends) is excessive and, in such a case, the entire synchronizer assembly must be replaced.

Inspect each synchronizer ring for wear of its key slots by measuring the width of each slot. If the width reading exceeds the limit shown in Figure 4G-17, replace the ring.

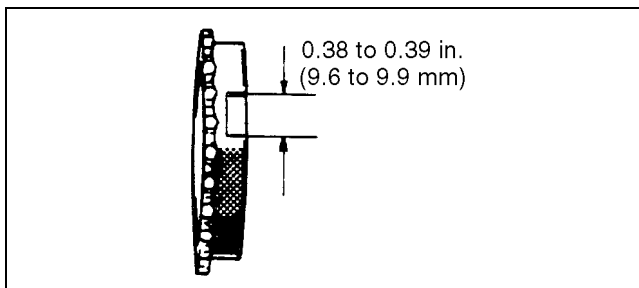

Figure 4G-17. Synchronizer Ring Slot Wear

FORK SHAFT LOCATING SPRINGS

Locating springs are used as retainers for the three shifter fork shafts. If gears have been slipping out of mesh, check these springs for strength by measuring

their free lengths (see Figure 4G-18), and replace them if their free lengths are less than 0.727 inch (18.45 mm).

Spring Free Length ó Standard	Spring Free Length ó Service Limit
0.807 inch (20.5 mm)	0.727 inch (18.45 mm)

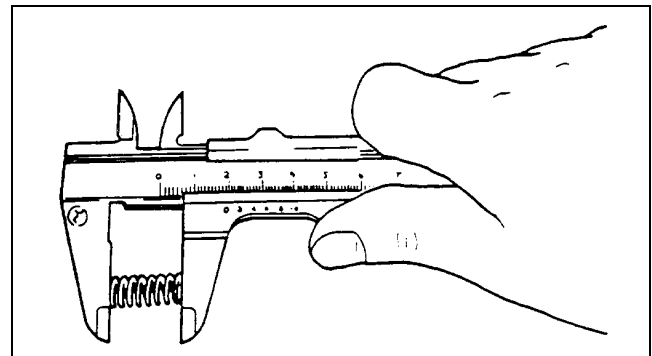

Figure 4G-18. Checking Locating Spring Free Length

4G

GEAR SHIFT FORK SHAFTS

Check the shift fork shafts at the gear shift lever end (see Figure 4G-10) for uneven wear. Replace worn shift fork shafts.

EXTENSION CASE BUSHING

Check the bushing press-fitted into the extension case for wear by measuring the radial clearance between bushing bore and sliding yoke as shown in Figure 4G-19. If the sliding yoke is capable of rattling in the bush because of advanced wear it will cause the drive shaft to rattle. For this reason, an extension case found to allow the drive shaft yoke to rattle in excess of 0.004 inch (0.1 mm) must be replaced; replacement of the bushing alone will not fix the problem.

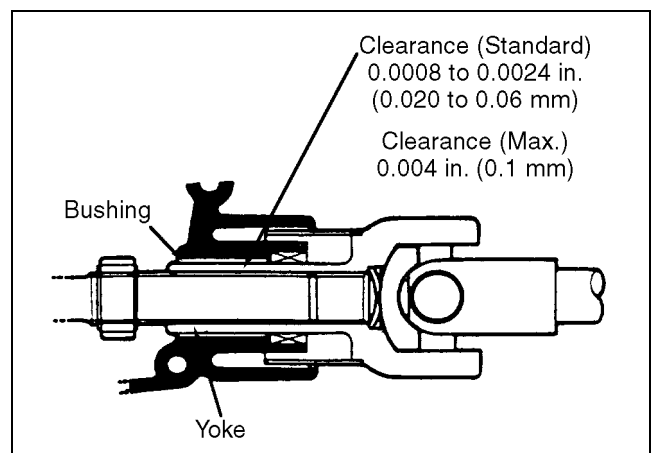

Figure 4G-19. Bushing-to-Yoke Clearance

DRIVE TRAIN

SECTION 4H. TRANSMISSION (DIESEL ENGINES)

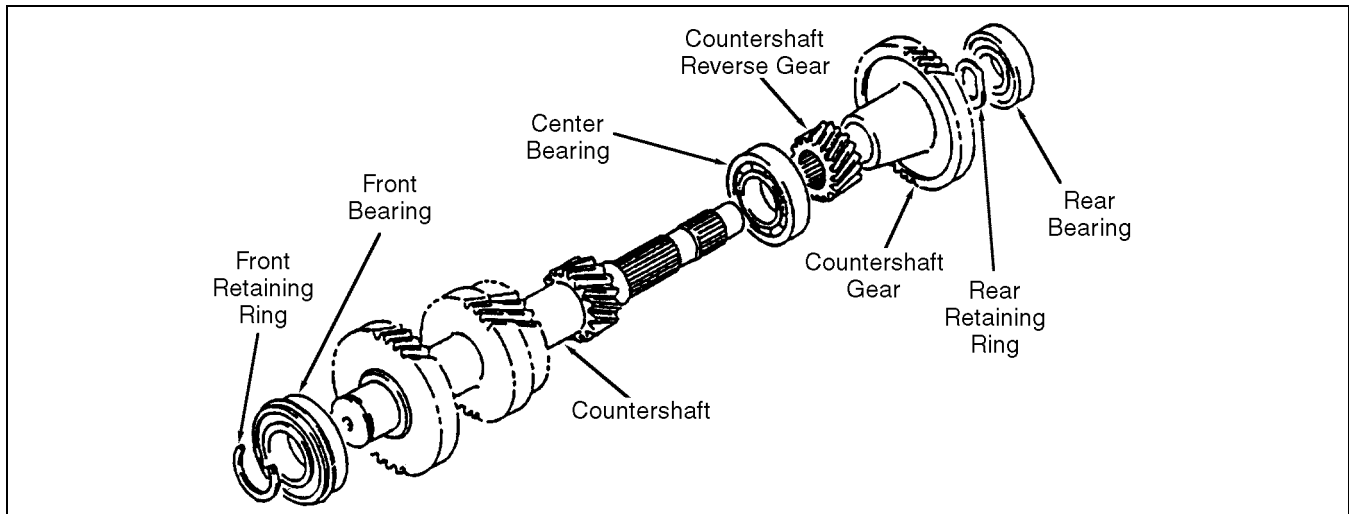

Figure 4H-6. Countershaft Disassembly

COUNTERSHAFT

1. Use a bearing puller to pull the rear bearing (see Figure 4H-6) off the countershaft.
2. Remove the rear retaining ring and PTO drive gear.

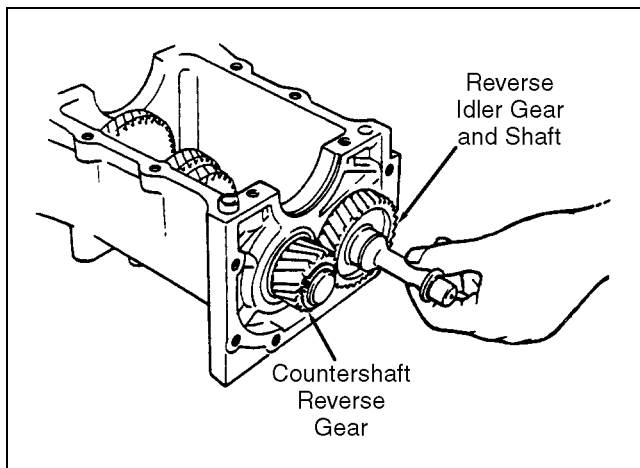

Figure 4H-7. Reverse Idler Gear and Shaft

3. Remove reverse idler gear and shaft (see Figure 4H-7).
4. Remove the countershaft reverse gear (see Figure 4H-6).
5. Remove front retaining ring from countershaft. Push out countershaft to extension case side by using hydraulic press. Take countershaft assembly out of case (see Figure 4H-8).

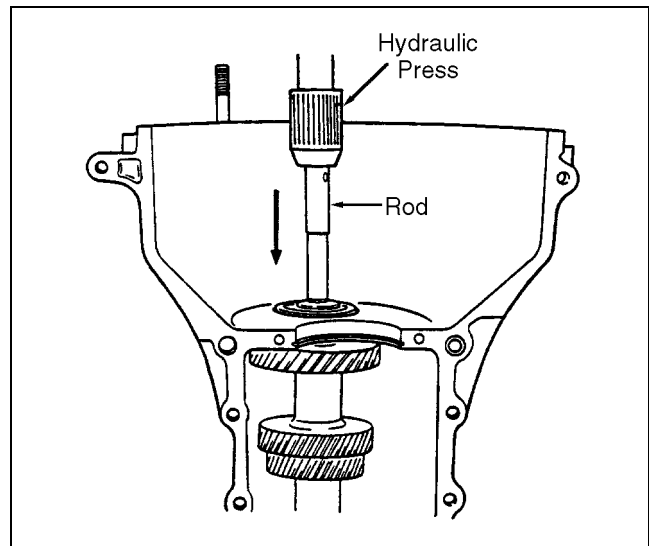

Figure 4H-8. Countershaft 6 Step 5

INPUT SHAFT AND MAIN SHAFT

1. Refer to Figure 4H-9, remove the oil seal, retaining ring, bearing and input shaft. Pull out the input shaft, by hand, taking care not to drop the high speed synchronizer rings.
2. Remove the retaining ring, high speed synchronizer rings, springs, needle bearings, high speed hub and sleeve, and third driven gear from the main shaft.
3. Remove retaining ring for speedometer drive gear and slide off speedometer drive gear.
4. Remove retaining ring and reverse synchronizer hub from main shaft.
5. Remove reverse drive hub, reverse gear and reverse gear needle bearing.

DRIVE TRAIN

SECTION 4H. TRANSMISSION (DIESEL ENGINES)

MAIN SHAFT AND INPUT SHAFT

1. See Figure 4H-26 for general arrangement of the countershaft, main shaft and input shaft.

NOTE

Be careful to install each washer, gear, synchronizer hub and sleeve in the proper direction. Make sure that balls are installed on the main shaft.

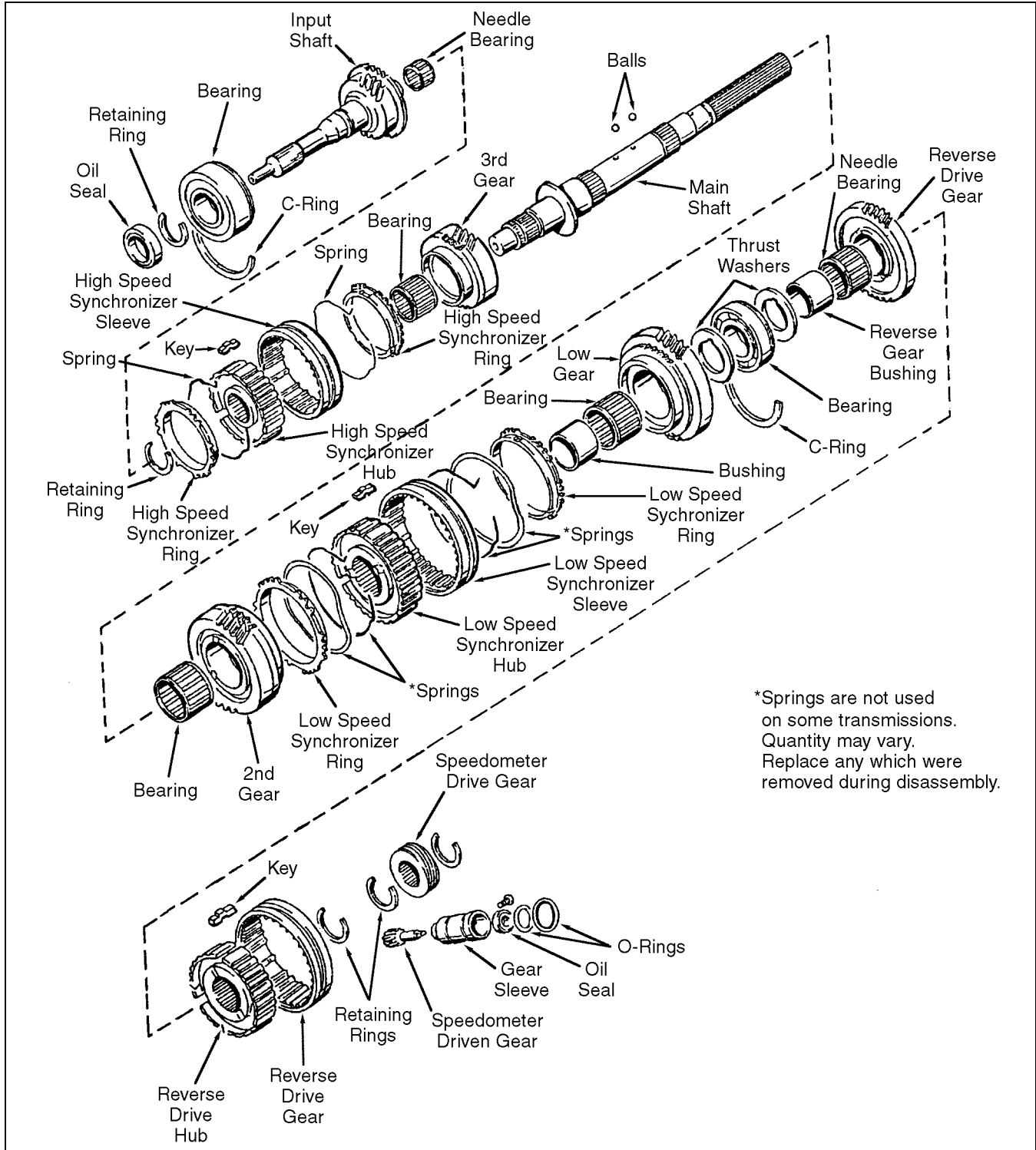

Figure 4H-26. Main Shaft and Input Shaft

DRIVE TRAIN

SECTION 4J. AUTOMATIC TRANSMISSION REPAIR

TRANSMISSION REMOVAL

1. Disconnect the negative (n̄) and positive (+) battery cables from the battery terminals.
2. Disconnect the shift cable from the shift switch.
3. Tag and disconnect all cables, hoses or tubes which are connected to the transmission or which would obstruct lifting the transmission out of the frame.
4. Remove any sheet metal that would obstruct lifting the transmission out of the frame.
5. Remove the transmission drain plug located at the bottom left, rear corner of the transmission oil pan (see Figure 4J-1) and drain automatic transmission fluid (ATF) into an environmentally approved container. Replace O-ring and install the drain plug and torque it to 13 to 19.5 ft-lbs. (17.6 to 26.5 N.m).
6. Disconnect the drive shaft at the transmission (see SECTION 4C).
7. Attach a suitable hoist to the transmission.
8. Remove hardware that fastens the transmission to the engine.
9. Remove any remaining hardware from mounting brackets on the frame until the transmission is free to be lifted.
10. Carefully move the transmission away from the engine flywheel and move the transmission out of the frame to a suitable work stand.

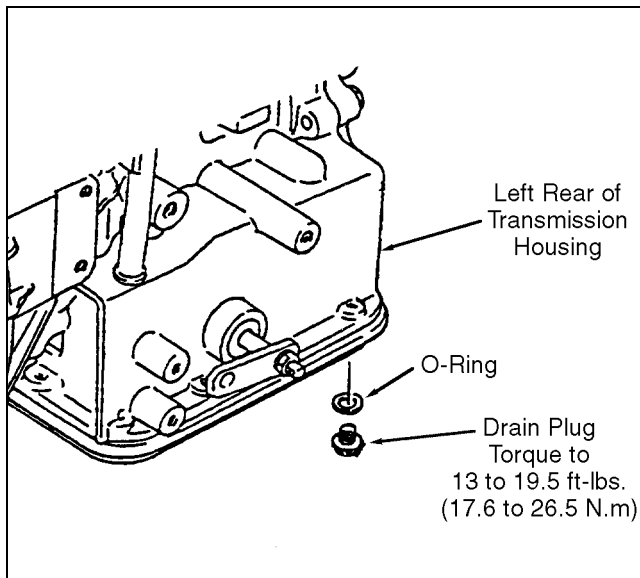

Figure 4J-1. Transmission Drain Plug Location

DISASSEMBLY AND REASSEMBLY

GENERAL

Rarely (if ever) will all the disassembly and reassembly steps in this section be required. Plan ahead to minimize the number of major components to be removed when repairing the transmission. For example, the oil pan and manually controlled valve (at the base of the transmission) and the second brake piston (at the side) can be removed without removing internal gearing.

The sequence of procedures in this section assume major overhaul/repair work which requires repair of the planetary gears, clutches, etc.

Refer to SECTIONS 4B, 4E and 4J to help determine the necessary repairs prior to undertaking the disassembly and reassembly procedures in this section.

ELECTRICAL/ELECTRONIC COMPONENTS

(See Figure 4J-2)

After disconnecting all cables from electrical/electronic components mounted on the exterior of the transmission, remove these components as shown in Figure 4J-2.

Test these components as described in SECTION 10 and replace them if they do not meet test requirements.

In addition to these components, two shift solenoids are mounted on the control valve beneath the oil pan (see 'Oil Pan' later in this section).

DRIVE TRAIN

SECTION 4J. AUTOMATIC TRANSMISSION REPAIR

2. Use a spring compression tool to push down the spring seat far enough to remove the spring seat snap ring as shown in Figure 4J-13. Remove the spring seat and return spring.

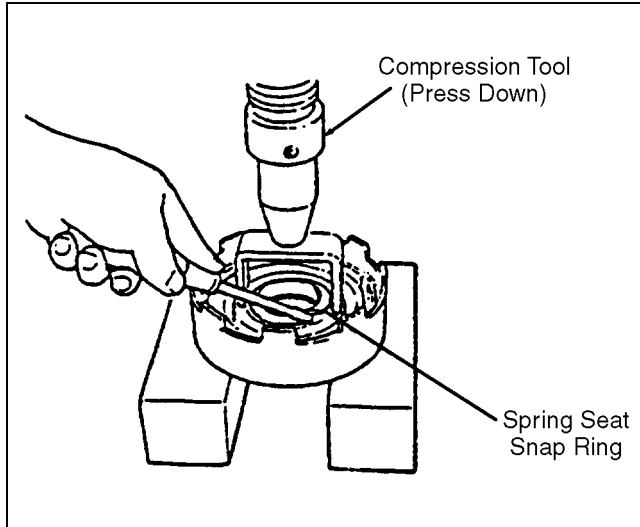

Figure 4J-13. Remove Spring Seat Snap Ring

3. Refer back to Figure 4J-12 and remove the outer O-ring and piston from the direct clutch drum. If necessary, blow air from an air gun through the front hole in the clutch drum to free up the piston from the drum.
4. Make certain that the check valve ball in the piston moves freely. Clean with compressed air to free up the valve ball.
5. Remove the inner O-ring and inner and outer washers.
6. Starting at the forward clutch flange snap ring, repeat Steps 1 through 4 above to remove the forward clutch components from the input shaft drum.
7. If necessary, remove the bearing races, bearing and input shaft seals, check the input shaft spline for wear or damage. Replace worn or damaged parts.

Reassembly (See Figure 4J-12 and the Following Step-by-Step Illustrations)

1. Starting at the direct clutch piston (see Figure 4J-12), replace the inner and outer O-rings on both sides of the direct clutch piston. Lubricate the new O-rings with ATF before installing.
2. Insert the piston and O-rings into the direct clutch drum being very careful not to twist or drop the O-rings.
3. Install the return spring, spring seat and spring seat snap ring making certain the snap ring fits into the four tabs on the spring seat.
4. Install the clutch plate disks and plates alternately in the direct clutch drum. If new clutch disks are to be installed, soak them in ATF for at least 2 hours prior to installation.
5. Install the flange on the last plate disk with the larger diameter of the flange turned away from the disk.
6. Use a spring compressor to push down on the spring seat and install the direct clutch flange snap ring as shown in Figure 4J-14.

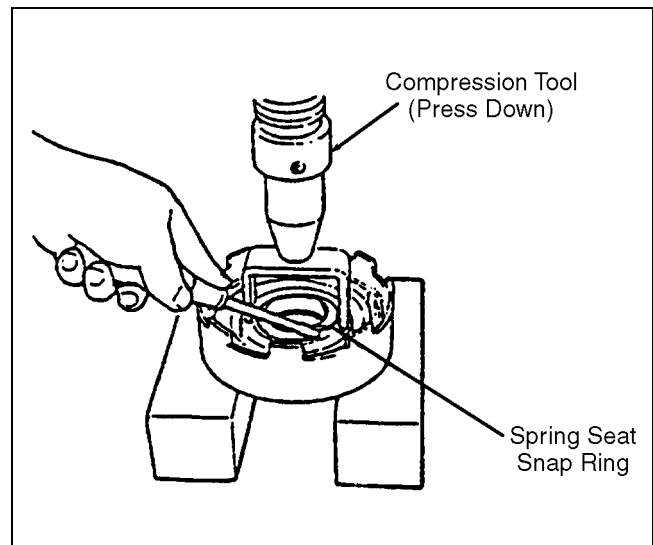

Figure 4J-14. Direct Clutch Reassembly ó Step 6

SECTION 4J. AUTOMATIC TRANSMISSION REPAIR

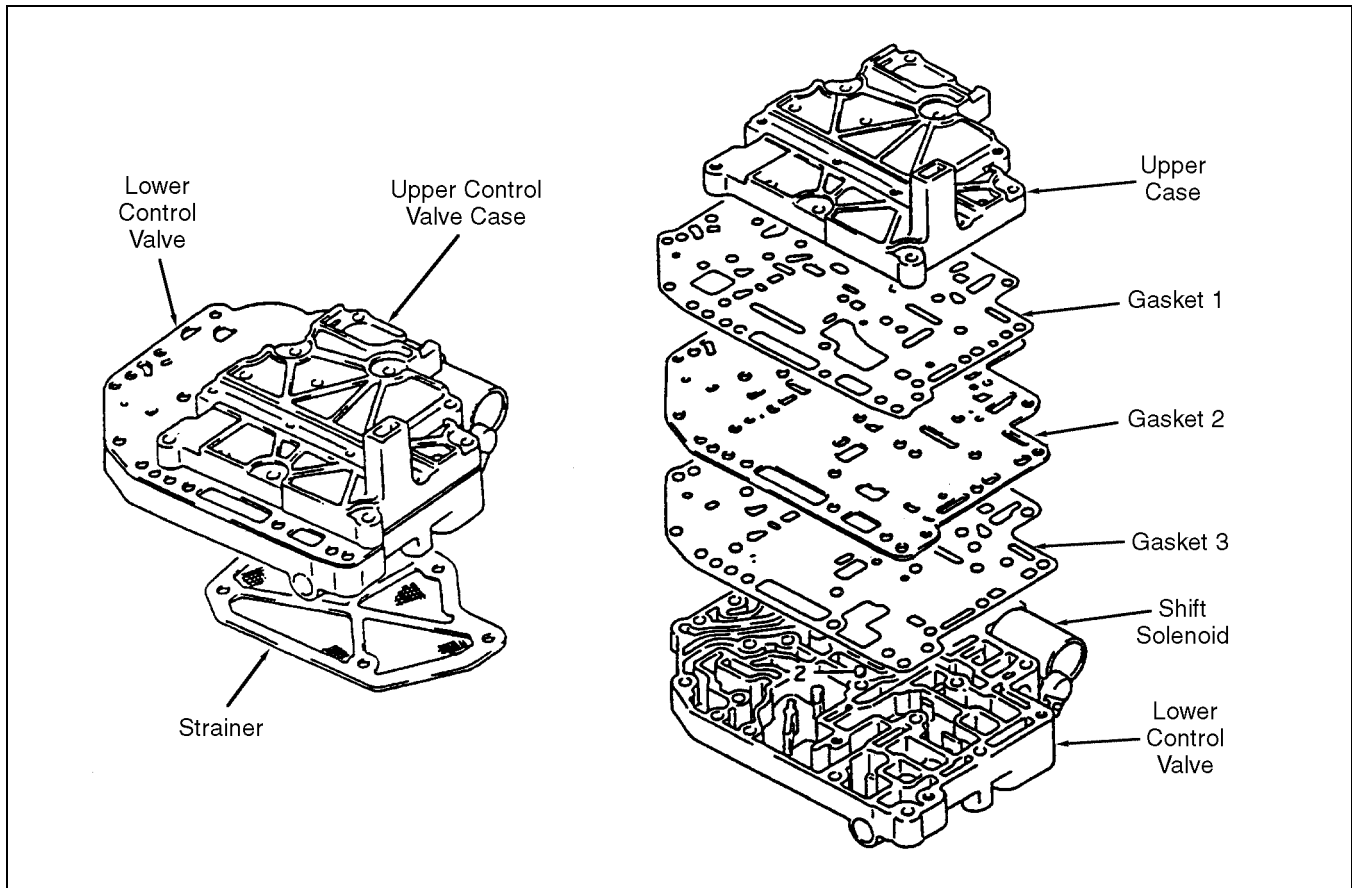

Figure 4J-34. Upper and Lower Control Valve Arrangement

Oil Strainer Removal

With the transmission turned upside down and the oil pan removed, remove the five mounting bolts and pull the strainer off the lower control valve housing (see Figure 4J-34).

NOTE

After the strainer is removed, the shift solenoids can be removed for testing and/or replacement (see Figure 4J-37 for mounting of solenoids on the control valve lower housing).

Control Valve Removal (See Figure 4J-35)

1. Pull the cotter pins out of the shift lever rods and remove the shift lever rods.
2. Remove the twelve mounting bolts that hold the control valve to the transmission housing and remove the assembled control valve.

NOTE

Code (mark) each of the mounting bolts and its mounting hole; the bolts are of four different lengths.

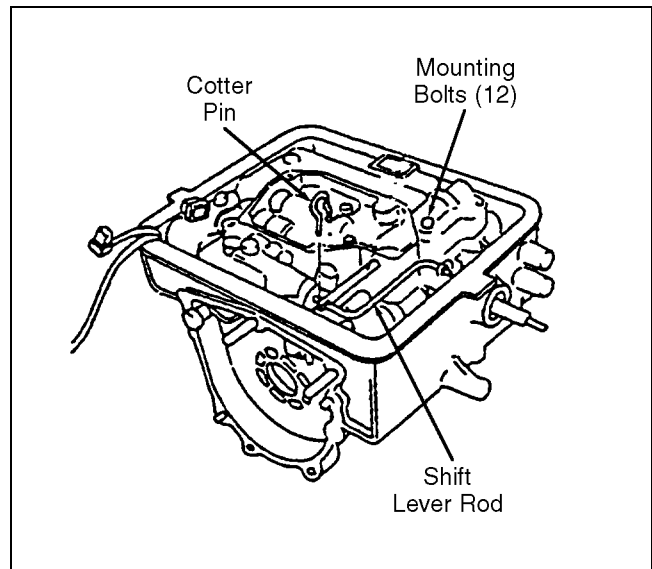

Figure 4J-35. Control Valve Removal

SECTION 4K. REAR AXLE

INSTALLATION

1. Refer to Figure 4K-3, replace the O-ring and oil seal. Lubricate the oil seal. The lip of the oil seal must face inward. Use a plastic tube or seal driver to seat the oil seal.
2. Pack the wheel bearing with clean grease (see SECTION 11). Reassemble the wheel bearing and collar being careful not to damage the oil seal (see Figure 4K-3). The bearing cup should be to the differential housing side.
3. Refer to Figure 4K-2, install U-bolts and shocks on axle tubes. Torque as shown in Figure 4K-2.
4. Install the brakes and wheel hubs as described in the preceding paragraphs.

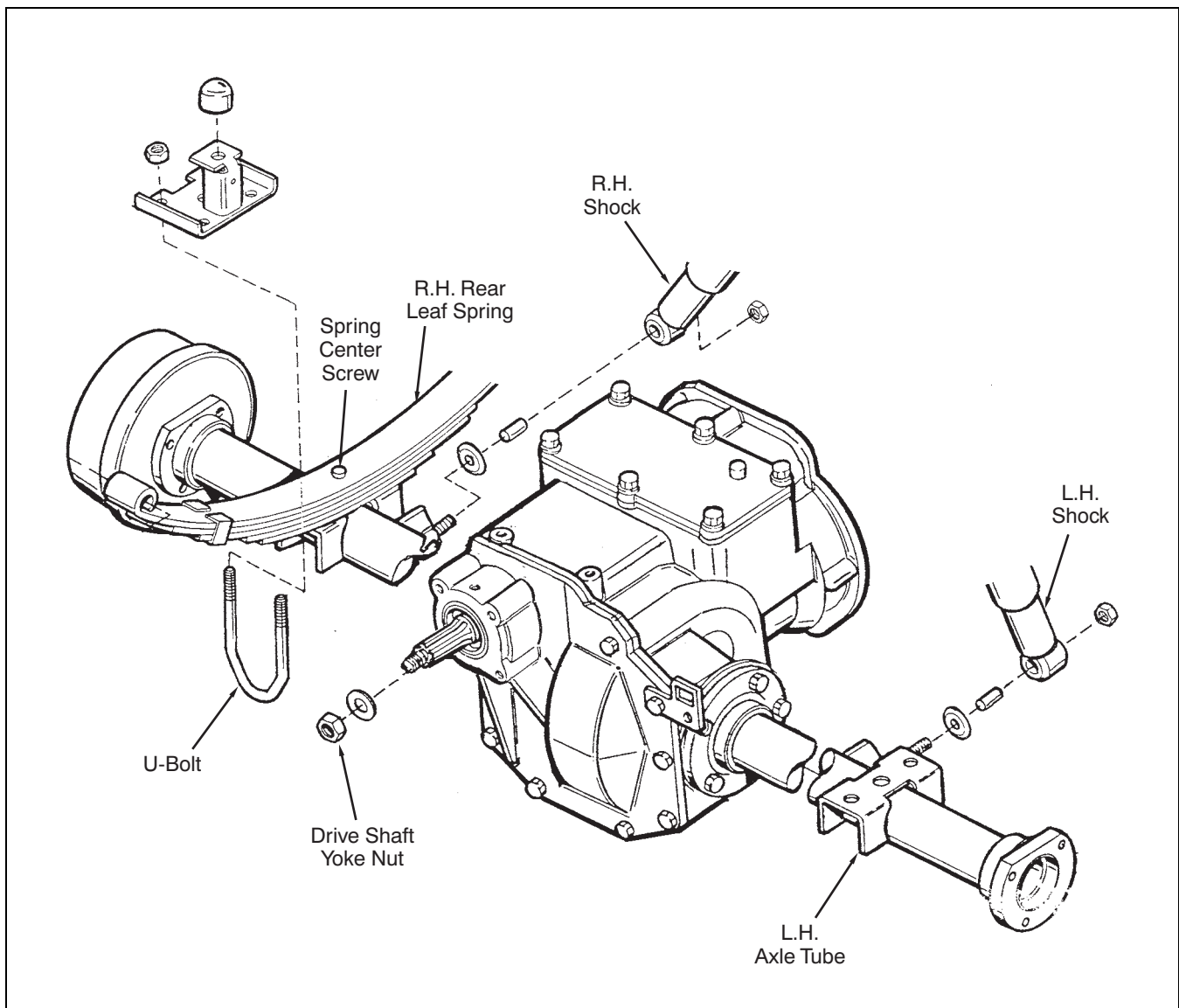

Figure 4K-2. Axle Housings and Differential

CLICK HERE TO **DOWNLOAD** THE COMPLETE MANUAL

- Thank you very much for reading the preview of the manual.
- You can download the complete manual from: www.heydownloads.com by clicking the link below



- Please note: If there is no response to CLICKING the link, please download this PDF first and then click on it.

CLICK HERE TO **DOWNLOAD** THE COMPLETE MANUAL