



**WACKER  
NEUSON**

# Repair Handbook

**Telehandlers**

**TH627**



<b>Machine model</b>	<b>418-02</b>
<b>From serial no.</b>	<b>418 02 0011</b>
<b>Version</b>	<b>2.0</b>
<b>Document number</b>	<b>1000363128</b>
<b>Language</b>	<b>[en]</b>

CLICK HERE TO **DOWNLOAD** THE COMPLETE MANUAL

- Thank you very much for reading the preview of the manual.
- You can download the complete manual from: [www.heydownloads.com](http://www.heydownloads.com) by clicking the link below



- Please note: If there is no response to CLICKING the link, please download this PDF first and then click on it.

CLICK HERE TO **DOWNLOAD** THE COMPLETE MANUAL

---

## Jack up the machine

---



### **WARNING**

#### **Crushing hazard due to incorrectly jacked-up machine.**

Serious injury or death of persons underneath the machine can be caused if the machine lowers or falls down.

- ▶ Use jack/jack stand of sufficient lifting capacity.
  - ▶ Use hydraulic jacks/jack stands that function reliably.
  - ▶ Use the jack/jack stand on firm and level ground.
  - ▶ Install a jack/jack stand at a suitable position on the machine.
- 

## Parking the machine

Perform the following steps before working on the machine:

- Stop the diesel engine.
- Apply the parking brake.
- Remove the starting key.
- Remove key from main battery switch.
- Wait until all parts of the machine have come to a complete standstill.
- Secure the machine with wheel chocks.
- Ensure that the machine cannot be put into operation by other persons.

## Air conditioning

---



### **Environment**

The air-conditioning system is filled with an HFC refrigerant which can damage the atmosphere. Be particularly careful when working on the air conditioning system. Maintenance and repair work may only be performed by specialized cryo-service centers. Refrigerant must always be extracted and recycled properly

---



**Shape H with O-ring and chamber ring**

<b>Dimension</b>	<b>Tightening torque (lightweight series) in Nm (ft.lb)</b>	<b>Tightening torque (heavy series) in Nm (ft.lb)</b>
G 1/8 A	20 (14,8)	20 (14,8)
G 1/4 A	40 (29,5)	40 (29,5)
G 3/8 A	75 (55,3)	75 (55,3)
G 1/2 A	85 (62,7)	85 (62,7)
G 3/4 A	180 (132,8)	180 (132,8)
G 1 A	310 (228,6)	310 (228,6)
G 1-1/4 A	450 (331,9)	450 (331,9)
G 1-1/2 A	540 (398,3)	540 (398,3)

## Safety prop for telescopic boom



Fig. 2

### Mounting the safety prop onto the lift ram

#### **WARNING**

**Crushing hazard! Assembly and maintenance on the raised telescopic boom not secured by a prop!**

Causes serious injury or death.

- ▶ Install safety prop (supplied with the machine) onto the extended lift ram and secure it with pin (or a screw, see figure).

#### **NOTICE**

Install it as shown in the figures in order to avoid damage to the piston rod and the safety prop!

- ▶ The opening of the safety prop must face down!

The safety strut is located at the front left on the machine frame.

1. Remove the attachment (loader bucket)
2. Park the machine on firm and level ground
3. Apply the parking brake
4. Retract the telescopic boom and raise the loader unit so that the safety prop can be attached without danger.
5. Stop the engine and remove the starting key.
6. Remove the safety prop from the installation location. To do this, remove the plug fuse and unscrew the bolt **B** from the tapped bore.
7. Place the safety prop on the extended piston rod of the lift cylinder from below and turn via the piston rod.
8. The opening of the safety prop must face down.
9. Lock the safety prop with bolt **A** and secure it with the safety pin (see figure).
10. **When the diesel engine is idle:** carefully lower the telescopic arm onto the safety prop using emergency lowering – see operating manual "Emergency lowering of the charging unit when diesel engine breaks down".
11. After maintenance work, remove the safety prop from the lift cylinder and attach at the predetermined installation location (front left in the vehicle frame)!



## Relays in the foot area (start interlock)

The relays are located under the cover, next to the accelerator.

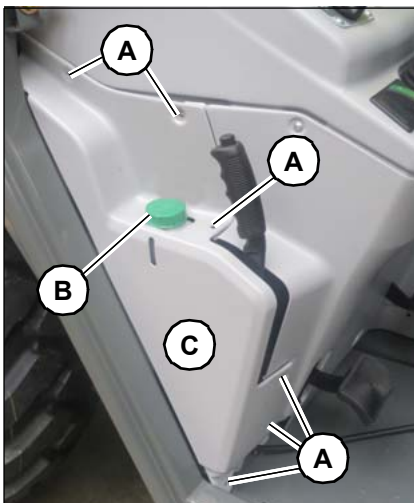

Fig. 12

1. Switch off battery master switch **S008** – see *"Switch off the battery master switch S008" on page 1-4.*
2. Remove screws **A**.
3. Remove cover **B** from the expansion tank.
4. Remove cladding **C**.

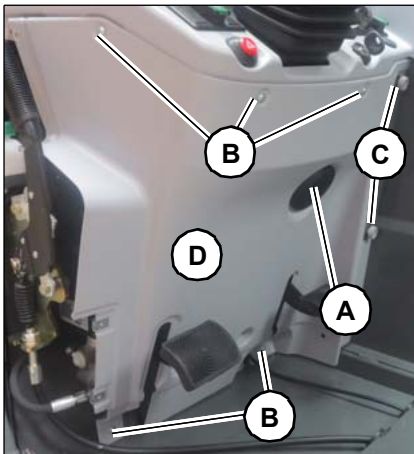

Fig. 13

5. Dismantle ventilations nozzles **A**.
6. Remove screws **B**.
7. Remove knurled screws **C**.
8. Remove trim **D**.

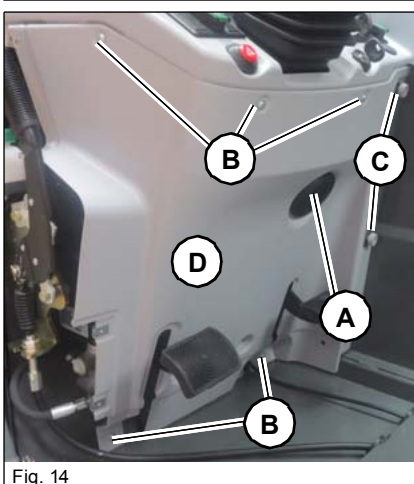

Fig. 14

9. Position trim **D**.
10. Tighten knurled screws **C**.
11. Tighten screws **B**.
12. Fit the ventilation nozzles **A**.



---

## Lubricating the telescopic boom

---



### Information

Maintenance intervals – see *"Maintenance plan" on page 1-7*.  
Lubricants – see *"Fluids and lubricants" on page 1-17*.

---

1. Set the quickhitch facility to a horizontal position.
2. Only raise the loader unit until all grease zerks can be accessed without any risk.
3. Stop the engine.
4. Apply the parking brake.
5. Switch off the starter and remove the starting key.
6. Lubricate the lubrication points with a suitable tool.
7. Always lubricate the pad tracks regularly on the inside and outside telescopic boom sections with a suitable tool – see *"Lubricate the pad tracks" on page 1-36*.

## Lubricating with the central lubrication system (option)

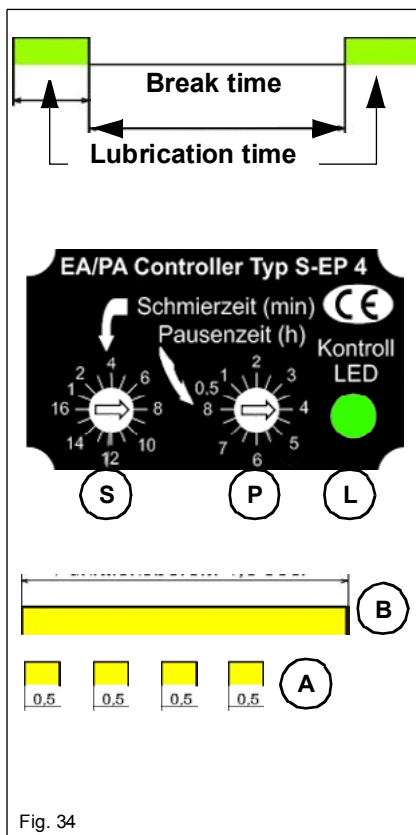

### Setting the lubrication and break times

Break times and lubrication times are set with the notched switches **S** and **P** in the window of the controls.

1. Remove the red frame on the protective motor housing of the pump with a flat screwdriver to set the time.
2. Loosen the four cross-slotted screws and remove the transparent cover.
3. Set the break time **P** and the lubrication time **S** with a flat screwdriver.
4. Install the transparent cover (window) once the settings are performed.

### Lubrication times (S)

- 1 to 16 min. (16 notches each up to 1 min.)
- 2 to 32 min. (16 notches each up to 2 min.)

### Break time (P)

- 0.5 to 8 h (16 notches, 0.5 h each)

### Yellow LED (L)

- **(B)** lubrication system in operation
- **(A)** lubrication in progress: 0.5 seconds LED ON/0.5 seconds LED OFF

### NOTICE

Water can penetrate into the controls and cause lubrication system failure if the cover is not fitted and closed correctly!

## Adding engine oil

### NOTICE

Damage due to incorrect engine oil level.

- ▶ The oil level must not drop below the “Min” mark on the engine oil dipstick.
- ▶ The oil level must not rise above the “Max” mark on the engine oil dipstick.

### NOTICE

Damage due to wrong engine oil.

- ▶ Maintenance intervals – see *“Maintenance plan” on page 1-7.*
- ▶ Specifications and fill quantities – see *“Fluids and lubricants” on page 1-17.*



### Environment

Use a suitable container to collect the engine oil as it drains and dispose of it in an environmentally friendly manner!

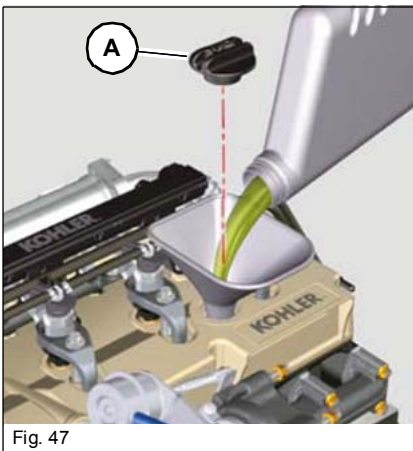

Fig. 47

1. Clean the area around oil filler cap **A** with a lint-free cloth.
2. Open the filler cap **A**.
3. Pull out oil dipstick **B** and wipe it with a lint-free cloth.
4. Add engine oil.
5. Wait a moment until all the oil has run into the oil sump.
6. Check the oil level with oil dipstick **B**.
7. Add oil if necessary and check the oil level again.
8. Close filler cap **A**.
9. Completely remove all oil spills from the engine.

### NOTICE

If the engine oil level is too low or if an oil change is overdue (black engine oil), this can cause **engine damage or loss of output!**

- ▶ Change the oil every 500 hours of operation.

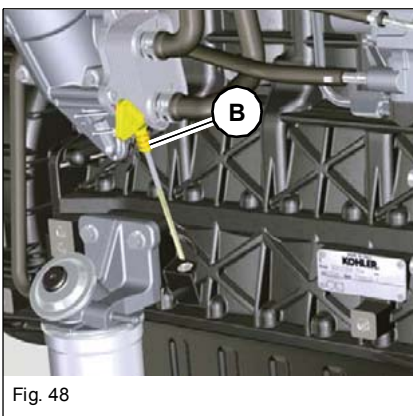

Fig. 48



## Information on inspection and cleaning work on the cooling system

Dirt on the radiator fins reduces the radiator's cooling capacity! To avoid this:

- Clean the outside of the radiator at regular intervals. The cleaning intervals can be found in the [Maintenance plan on page 1-7](#).
- In dusty or dirty work conditions, clean more frequently than indicated in the maintenance plans.
- An insufficient coolant level reduces the cooling capacity as well and can cause engine damage! Therefore:
  - Check the coolant level once a day.
- If the coolant must be replaced frequently, have the cooling system checked for leaks by an authorized service center!
- Never add cold water/coolant if the engine is warm!
- After filling the radiator, make a test run with the engine and check the coolant level again after stopping the engine.
- Add enough antifreeze to the coolant
- Use brand-name antifreeze agents since they already contain anticorrosion agents.

---

### NOTICE

In order to avoid sludge in the cooling system that damages the engine, do not use cooler-cleaning compounds if an antifreeze agent has been added to the coolant.

---

---

### NOTICE

In order to ensure the radiator's cooling capacity, do not damage the radiator fins as you clean them with a compressed-air gun!

- ▶ When blowing clear, ensure that excessively high air pressure does not occur.
- 



### Environment

Use a suitable container to collect the coolant as it drains and dispose of it in an environmentally friendly manner!

---

## Replacing the filter cartridge

### NOTICE

In order to avoid damage to the engine due to dirty intake air, bear in mind the following:

- ▶ Do not clean the air-filter elements with compressed air or a brush.
- ▶ Replace the air-filter elements when the indicator light illuminates.
- ▶ Never reuse damaged air-filter elements.
- ▶ Ensure cleanliness in the entire filter area when replacing the air-filter elements!
- ▶ Do not operate the engine without the air-filter elements.

### Information

Maintenance intervals – see *"Maintenance plan"* on page 1-7.

### Replacing the filter cartridge and safety cartridge:

### Information

To monitor filter element **E**, warning light **1** is located on the display instrument. If this illuminates, immediately replace the air filter cartridge.

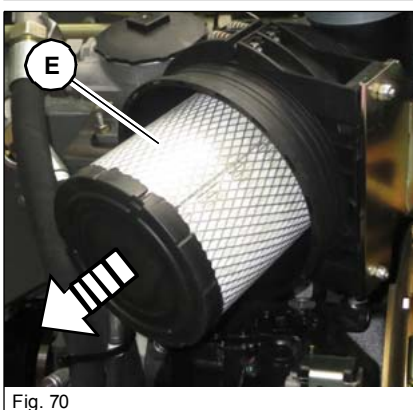
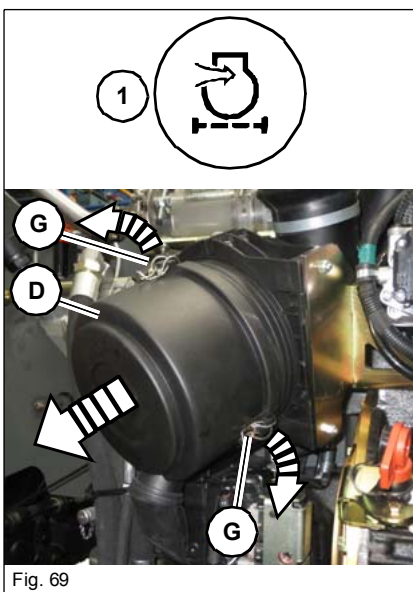

1. Stop the engine.
2. Apply the parking brake.
3. Switch off the starter and remove the starting key.
4. Open the engine cover – see *"Opening the engine cover"* on page 1-22.
5. Pull lock **G** outward on housing cover **D**.
6. Remove housing cover **D**.
7. Carefully remove filter cartridge **E** with slightly turning movements.

## 1.13 Hydraulic system

### Important information



Fig. 92

---

#### CAUTION

##### **Burn hazard due to hot hydraulic oil!**

Hot hydraulic oil can cause burns to the skin.

- ▶ Release the residual pressure in the hydraulic system.
  - ▶ Let the engine cool down.
  - ▶ Wear protective equipment.
- 

#### CAUTION

##### **Risk of injury from maintenance work!**

Injury hazard.

- ▶ Secure the raised telescopic boom on the lift cylinder with a safety prop to prevent unintentional lowering.
  - ▶ Release the pressure in all lines carrying hydraulic oil prior to any maintenance and repair work. To do this:
    - ▶ Lower the attachments to the ground.
    - ▶ Stop the engine and remove the starting key.
    - ▶ Apply the parking brake.
    - ▶ Actuate all control levers of the hydraulic controller several times for pressure relief.
  - ▶ Only work on the hydraulic system when the engine is switched off.
- 

#### **NOTICE**

Contaminated hydraulic oil, lack of oil or wrong hydraulic oil poses a risk of serious damage to the hydraulic system!

- ▶ Take care to avoid dirt when working!
  - ▶ Always add hydraulic oil using the filling screen!
  - ▶ Only use authorized oils of the same type.
  - ▶ Always add hydraulic oil before the level gets too low.
  - ▶ If the hydraulic system is filled with biodegradable oil, then only use biodegradable oil of the same type for adding oil – observe the sticker on the hydraulic oil reservoir.
-

## Checking the hydraulic system for leaks

### Safety instructions regarding pressure line checks

---



#### **CAUTION**

**Burn and injury hazard if hot hydraulic oil escapes under high pressure!**

Hydraulic oil escaping under high pressure can catch fire, damage property, penetrate the skin, and cause serious burns.

- ▶ Do not operate the machine with leaking or damaged hydraulic system components.
  - ▶ Never search for leaks with your bare hands, wear protective gloves and clothes.
  - ▶ Wear safety glasses to protect the eyes. If oil contacts the eye, flush immediately with clean water and seek emergency medical treatment.
  - ▶ Seek immediate medical attention if oil penetrates the skin. Oil can cause serious infections.
  - ▶ Retighten leaking threaded fittings and hose connections only when the hydraulic system is not under pressure. In other words, release the pressure before working on pressurized lines.
  - ▶ Never weld or solder defect or leaky pressure hoses and screw connections, but replace defect parts.
  - ▶ Do not check for leaks with an open flame due to explosive fire risk from vaporized oil mist.
-

## Cleaning/replacing the fine-dust filter

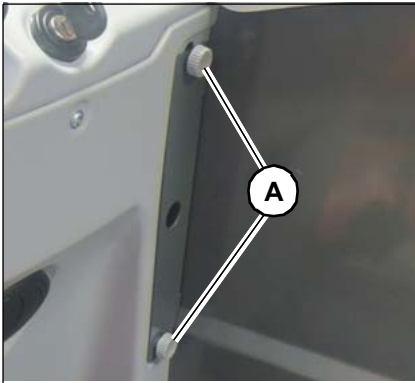

Fig. 121

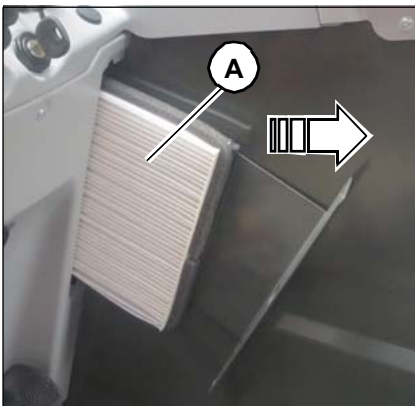

Fig. 122

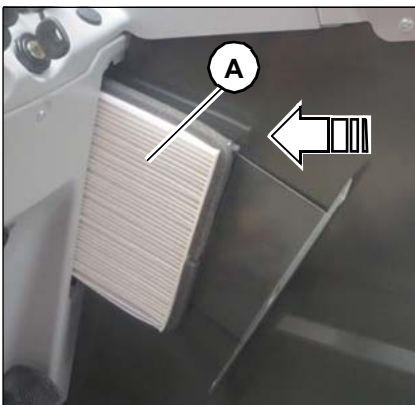

Fig. 123

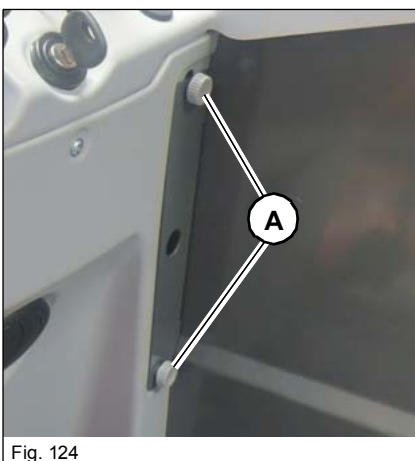

Fig. 124

### Information

Maintenance intervals – see *"Maintenance schedule"* on pages 1-6.

The fine-dust filter is located in the cabin on the right between the front and side trims.

1. Remove the knurled screws **A**.
2. Remove fine dust filter **A** and check for damage.
3. Knock the fine-dust filter **A** on a plate on either side.
4. Blow compressed air from the inside to the outside or wash it with water and let it dry, or replace it with a new one.
  - Replace fine dust filter **A** – see *Chapter 1 "Maintenance schedule"* on pages 1-6.
  - Replace or clean the filter more frequently if the machine is used in severe dust conditions.
5. Clean the inside of the filter housing.
6. Insert the cleaned/new fine dust filter **A**.

### NOTICE

When inserting fine-dust filter **A**, make sure the position is correct.

- ▶ The fine-dust filter **A** must touch all sides evenly.

7. Tighten knurled screw **A**.

## Checking/refilling oil at differential lock (rear axle)

### CAUTION

**Risk of burns when emptying hot gear lubricant oil!**

Can cause serious injury.

- ▶ Wear protective gloves!
- ▶ Use suitable tools, e.g. to unscrew the oil drain plug!

### Environment

Use a suitable container to collect the gearbox oil as it drains off and dispose of it in an environmentally friendly manner!

### Information

Only use new sealing rings for filler and drain plugs.

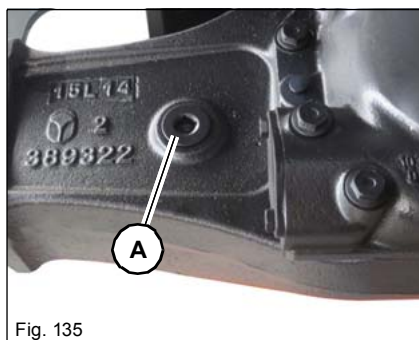

Fig. 135

1. Place the vehicle on firm and level ground with the differential at operating temperature.
2. Lower the telescopic boom fully.
3. Stop the engine.
4. Switch off the starter and remove the starting key.
5. Open the engine cover – see ["Engine cover" on page 1-22](#).
6. Switch off battery master switch **S008** – see ["Battery master switch S008" on page 1-4](#).

7. Place a suitable container under the differential.
8. Clean and unscrew the sealing plugs **A** of the filling and inspection opening.

If the oil level is below the fill or inspection opening or if the oil level cannot be seen:

- ➔ Add fresh oil through the fill and inspection opening up to the overflow.

If the oil level is correct:

- ➔ Screw in sealing plug **A** in the filling and inspection opening with a new sealing ring and tighten.

## 1.19 Pressure accumulator



### Information

The hydraulic accumulators may not be subjected to any welding or mechanical operations whatsoever!  
It is recommended to have the pilot control pressure inspected annually. This inspection may only be carried out by a skilled person with the respective qualification!



### DANGER

If the hydraulic accumulator is not filled correctly there is a risk of explosion!

If hydraulic accumulators are filled with oxygen or air, they explode. This will lead to serious injuries or death.

► Hydraulic accumulators may only be filled with nitrogen.



### DANGER

**Risk of suffocation!**

Inhaling nitrogen can lead to serious injuries and even death.

► Refill and drain hydraulic accumulators of nitrogen only outdoors or in rooms that are sufficiently ventilated.



### Information

It is important to read and observe the operating manual for the commercially available filling and testing device that is in use!

## 1.23 Camera system

### NOTICE

Improper cleaning of monitor and camera leads to damage to the equipment.

- ▶ Never clean the screen and camera with solvents, cleaning agents or other chemical products.
- ▶ Use a soft, dry cloth or a soft brush for cleaning.

### NOTICE

Using a high pressure cleaner may result in damage to components or electronics.

- ▶ Observe the Operator's Manual of the high-pressure cleaner.
- ▶ Ensure a minimum distance of at least 70 cm between the high-pressure nozzle and the object to be cleaned.
- ▶ Keep moving the water jet during cleaning.
- ▶ Do not point the jet directly at electronic components, plug-and-socket connections, seals or hoses.



Fig. 161

### Cleaning the screen

1. Park the machine safely.
2. Carefully clean the monitor **A** with a soft and dry cloth or with a soft brush.

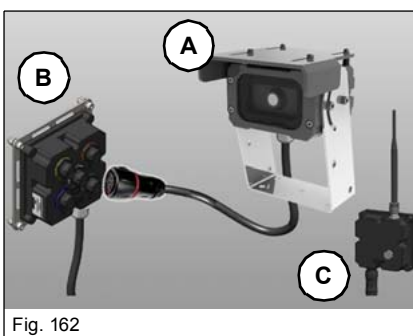

Fig. 162

### Cleaning the camera/switch box/transmission receiver

An optimal image is achieved by checking the front glass of the camera regularly for cleanliness and by cleaning it if necessary.

1. Park the machine safely.
2. Remove dirt from camera **A**, switch box **B** and video receiver **C** with water.  
Add a commercially available cleaning agent to the water if necessary.
3. Dry the front screen of the camera with a soft cloth or use a soft brush to remove dust. – See also [Replacing the front glass of the camera on page 1-136](#).

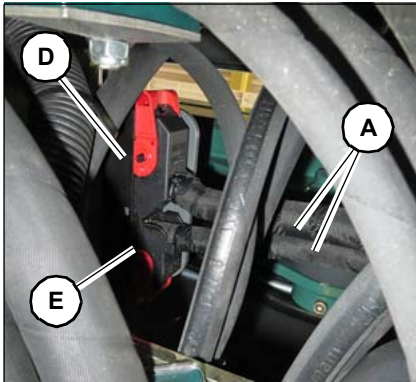

Fig. 10

- 35. Release and disconnect plug **D** and plug **E** of the engine wire harness **A** in the tunnel center.
- 36. Unscrew earth cable.

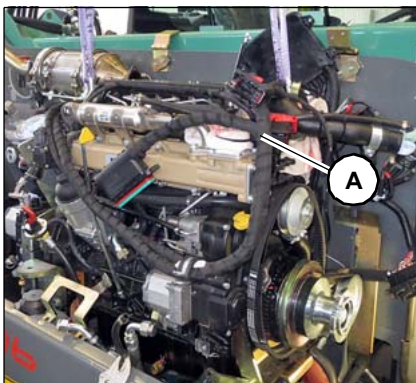

Fig. 11

- 37. Pull the engine wire harness **A** out upwards, place on the engine and secure.

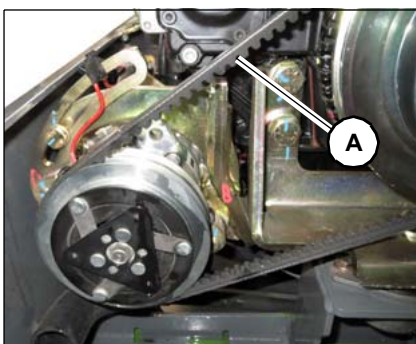

Fig. 12

Air conditioning compressor:

- 38. Relax fan belt **A** of the air conditioning compressor – see ["Removing the V-belt air conditioning \(opt\)"](#) on page 1-84.

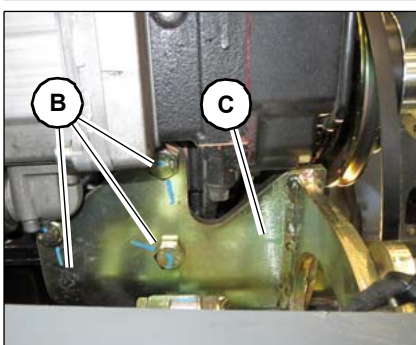

Fig. 13

- 39. Remove screws **B** of the air conditioning compressor bracket **C**.
- 40. Place air conditioning compressor with bracket **C** at the bottom of the engine vat.

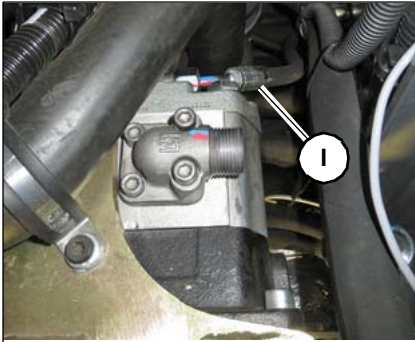

Fig. 49

Hydraulic hoses of the reversing fan engine:

31. Position overflow oil line and tighten sleeve nut **I** to 28 Nm (21 lbf.ft).

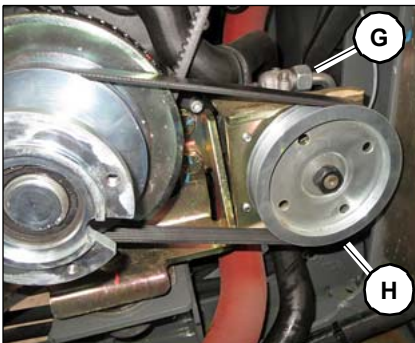

Fig. 50

32. Position hydraulic hose and tighten sleeve nut **G** to 60 Nm (44 lbf.ft).

33. Position hydraulic hose and tighten sleeve nut **H** to 60 Nm (44 lbf.ft).

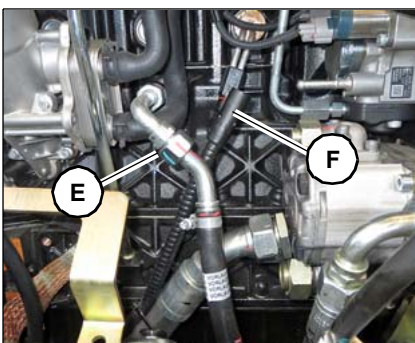

Fig. 51

Heating feed:

34. Position heater hose and tighten sleeve nut **E** to 50 Nm (37 lbf.ft).

35. If available, insert cable **F** of the engine pre-heater.

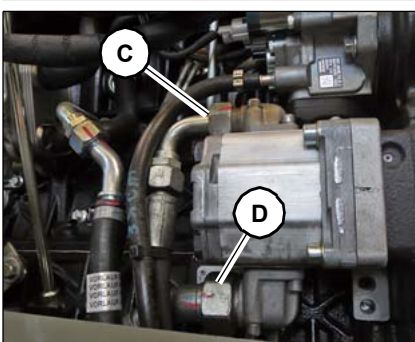

Fig. 52

Hydraulic hoses of the reversing fan pump:

36. Position hydraulic hose and tighten sleeve nut **D** to 60 Nm (44 lbf.ft).

37. Position hydraulic hose and sleeve nut **C** to 60 Nm (44 lbf.ft).

### Install the engine suspension in front

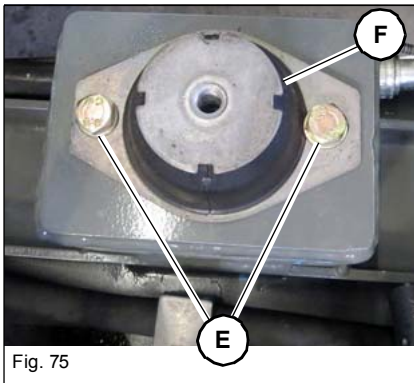

1. Insert the engine suspension **F** and mount with 2x screws **E**.
2. Tighten screws **E** to 46 Nm (34 lbf.ft).

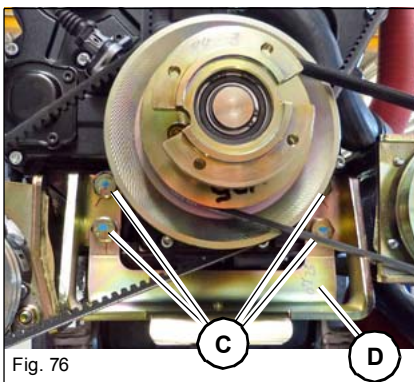

3. Insert the removed adjusting shims between the engine support and engine suspension.
4. Position the engine support **D**.
5. Mount 4x screws **C** with **Loctite® 243**.
6. Tighten screws **C** to 195 Nm (144 lbf.ft).

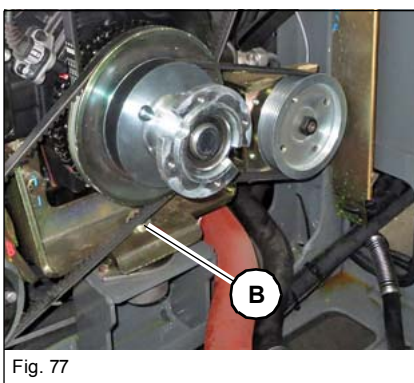

7. Loosely mount screw **B** on engine suspension, front.

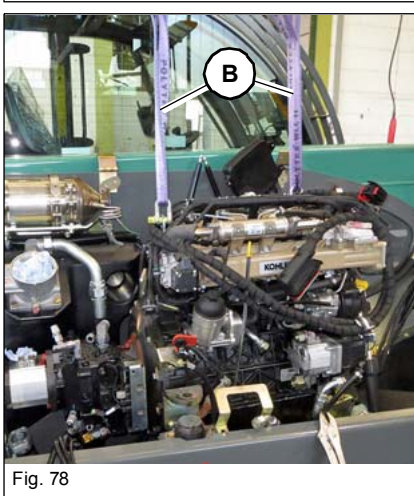

8. Carefully lower the engine with lifting gear **B**.

### Disassemble

1. Open the engine cover – see *"Engine cover" on page 1-22.*
2. Switch off battery master switch **S008** – see *"Battery master switch S008" on page 1-4.*
3. Remove V-belt cover – see *"Remove" on page 12-5.*

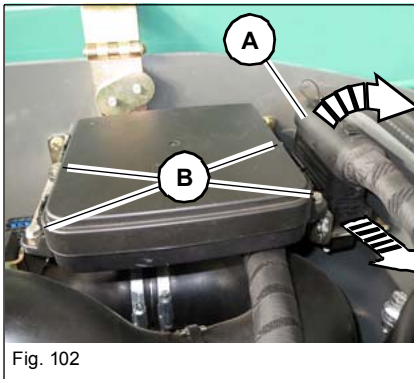

Main fuse box:

4. Unlatch plug **A** on main fuse box and unplug.
5. Remove screws on main fuse box **B**.

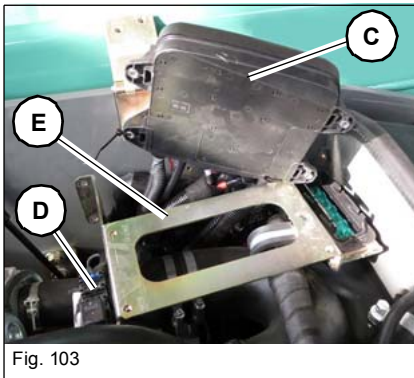

6. Flip main fuse box **C** upwards and secure with cable ties.
7. Unscrew fuse holder **D** on the mounting plate **E**.
8. Unscrew and remove mounting plate **E** on the frame.

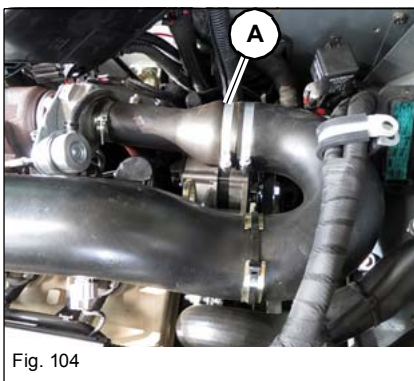

Air intake:

9. Loosen hose strap **A** and remove from connecting pipe.

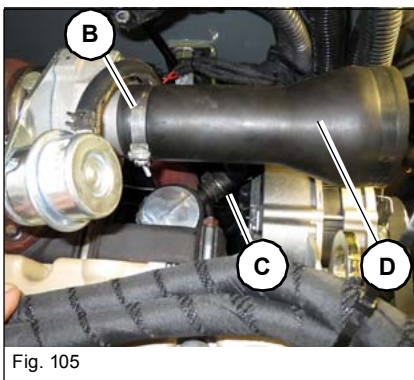

10. Loosen hose strap **B**.
11. Loosen clamp **C**.
12. Disconnect air intake hose **D** on turbocharger and oil vapor separator.
13. Protect turbocharger against pollution.

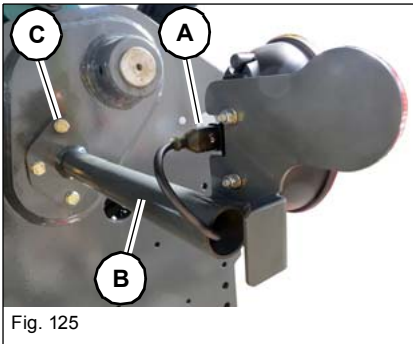

- 13. Disconnect the connector **A**.
- 14. Unscrew the light carriers **B C**.

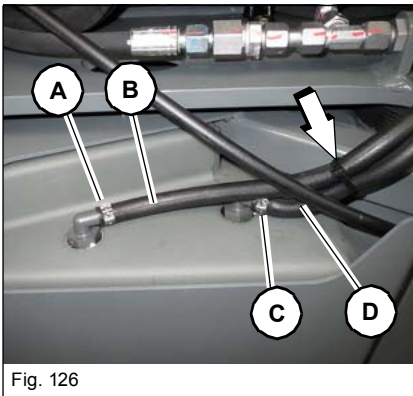

- 15. Remove the cable ties.
- 16. Mark the positions of the suction hose **B** and return flow hose **D**.
- 17. Loosen clamps **A** and remove suction hose **B** from fuel tank.
- 18. Loosen clamps **C** and remove return flow hose **D** from the fuel tank.

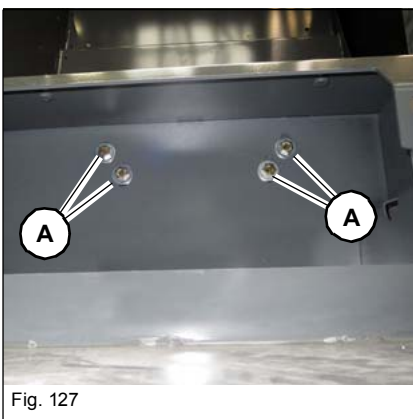

- 19. Remove the operator seat – see ["Remove/install driver's seat" on page 14-1](#).
- 20. Remove **A** screws in the tool box (below the operator seat).

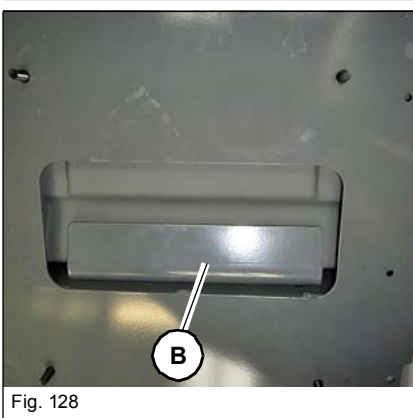

- 21. Remove the bar **B**.

## 2.9 Accelerator pedal R011

### Remove / install accelerator pedal

**i** Information

The safety and preparation instructions are to be taken into consideration before starting work

- see "Notes on the repair manual" on page E-1,
- see "Safety instructions" on page E-5,
- see "Maintenance preparations, instructions" on page 1-1!

#### Technical data

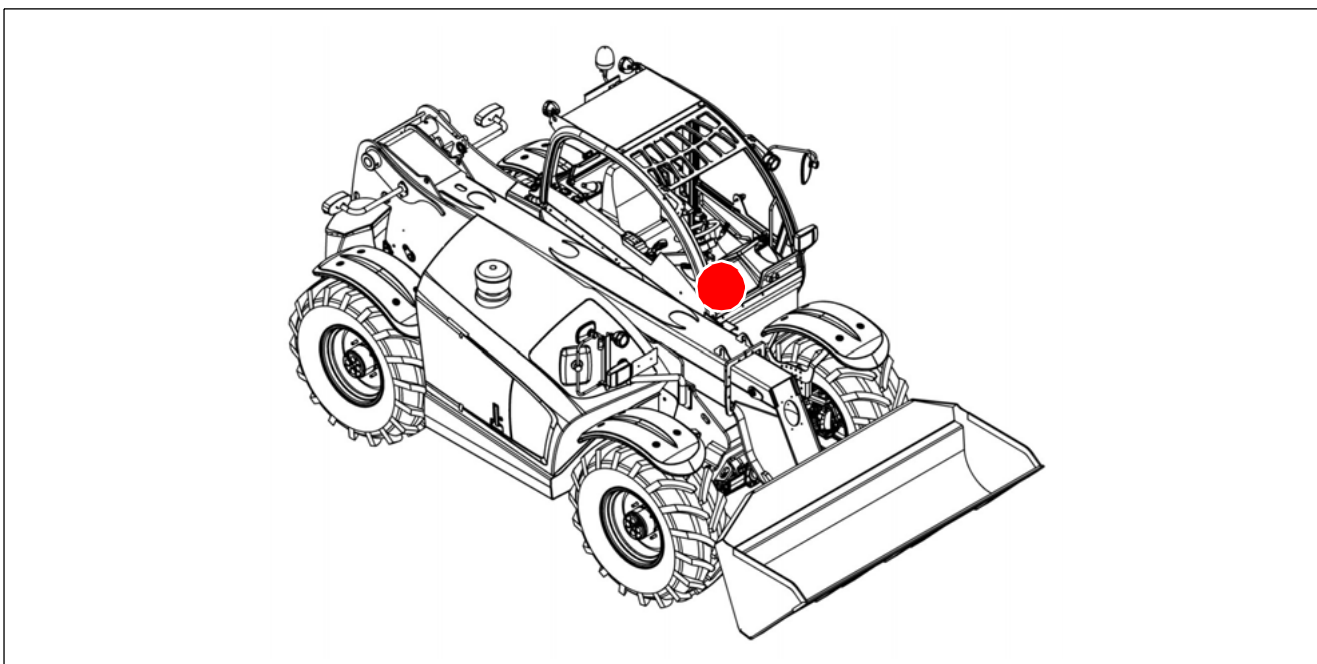

Weight	BMK	Remark/designation
0.3 kg (0.6 lb)	R011	Accelerator pedal
For non-specified tightening torques, see chapter "Introduction/tightening torques"		

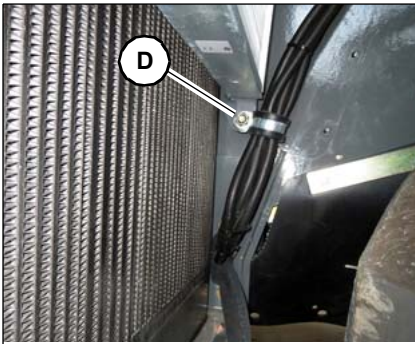

Fig. 18

22. Mount clamp and tighten nut **D**.

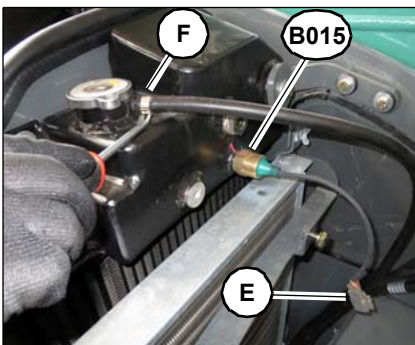

Fig. 19

23. Disconnect the plug **E** from the coolant level sensor **B015**.

24. Loosen clamp **F** and disconnect overflow hose.

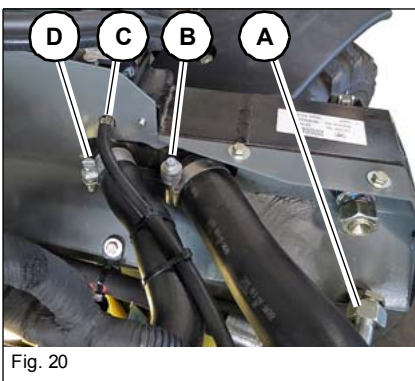

Fig. 20

On cooler at top:

25. Attach coolant hose and tighten clamp **D**.

26. Attach hose and tighten clamp **C**.

27. Attach charge air hose and tighten clamps **B** to 12 Nm (9 lbf.ft).

28. Position hydraulic hose and tighten sleeve nut **A** to 85 Nm (63 lbf.ft).

29. Remove vacuum pump and screw on the cover of the ventilation filter.

30. Fill air conditioning, if available – see ["Filling up the air conditioning system" on page 1-111](#).

31. Install V-belt cover – see ["Install" on page 12-6](#).

32. Fit the maintenance access (engine vat, bottom) – see ["Lower engine vat" on page 1-22](#).

33. Mount the maintenance access (engine vat, front) – see ["Close the maintenance access" on page 1-23](#).

34. Install engine cover – see ["Install" on page 12-3](#).

35. Fill coolant – see ["Adding coolant" on page 1-67](#).

36. Switch on battery master switch **S008** – see ["Battery master switch S008" on page 1-4](#).

37. Close the engine cover – see ["Engine cover" on page 1-22](#).

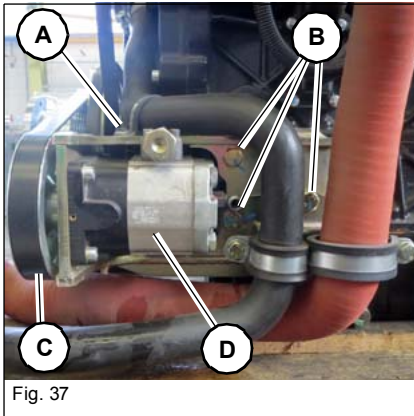

11. Attach the V-ribbed belt **C** and position the fan motor with bracket **D** to the diesel engine.
12. Loosely mount the screws **B** with Loctite® 243.
13. Align the pulley **F** with the pulley to the crankshaft.
14. Tighten screws **B** to 79 Nm (58 lbf.ft).
15. Mount the screw **A** at the clamp of the coolant hose.
16. Install the entire engine – see *"Install" on page 2-11*.
17. Install engine cover – see *"Install" on page 12-3*.
18. Switch on battery master switch **S008** – see *"Battery master switch S008" on page 1-4*.
19. Close the engine cover – see *"Engine cover" on page 1-22*.

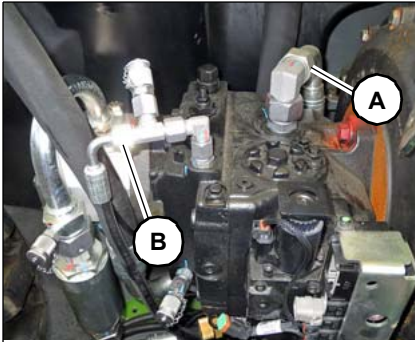

Fig. 7

Hydraulic hose lines on adjustment pump traction drive:  
21. Loosen sleeve nut **A** and remove hydraulic hose and drain.  
22. Loosen sleeve nut **B** and remove hydraulic hose and drain.

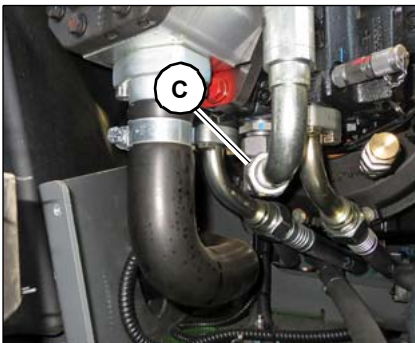

Fig. 8

23. Loosen sleeve nut **C** and remove hydraulic hose and drain.

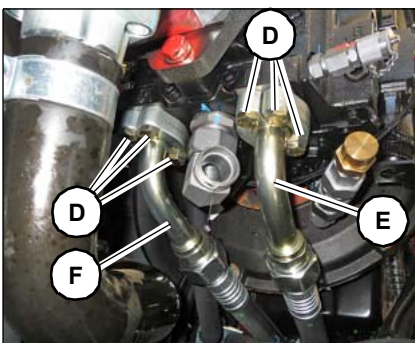

Fig. 9

24. Remove screws **D** and flange halves on the flange fittings.  
25. Remove high pressure pipes **E** and **F**.

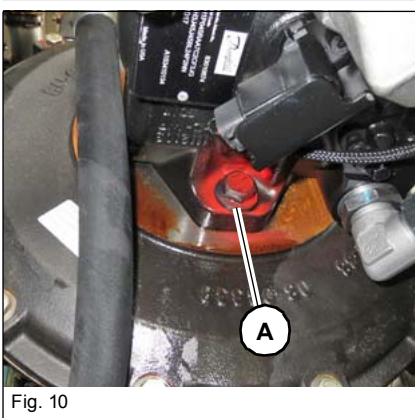

Fig. 10

Fitting the variable displacement pump:  
26. Remove screw **A** at the bottom of the variable displacement pump.

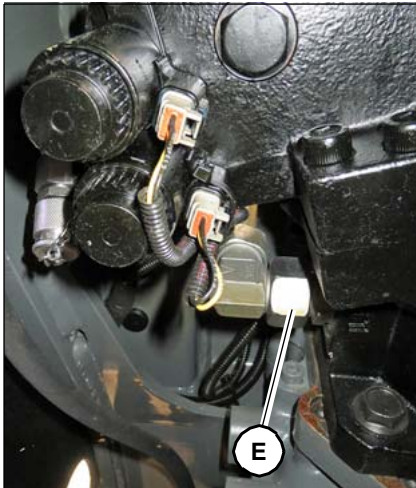

Fig. 35

9. Position hydraulic hose and tighten sleeve nut **E**.

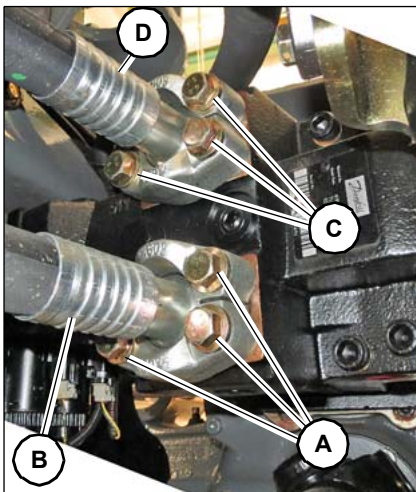

Fig. 36

10. Position high-pressure line **D** with new seal ring.

11. Mount flange halves to the flange fittings with **C** screws and tighten to 46 Nm (34 lbf.ft).

12. Position high-pressure line **B** with new seal ring.

13. Mount flange halves to the flange fittings with screws **A** and tighten to 46 Nm (34 lbf.ft).

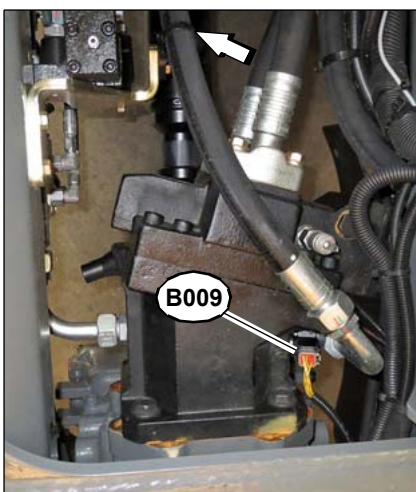

Fig. 37

Cable to the variable displacement motor traction drive:

14. Connect cable connectors **B009** (speed sensor).

15. Install the cable binder.

## 5.3 Screw connections and tightening torques

### Threaded fittings

**CONVERSION TABLES - TABELLE DI CONVERSIONE - UMRECHNUNGSTABELLEN  
TABLAS DE CONVERSION - TABLEAUX DE CONVERSION**

Units of pressure - Unità di pressione - Druckeinheiten  
Unidad de presión - Unités de pression:  $1 \text{ Atm} \cong 1 \text{ bar} \cong 10^5 \text{ Pa} \cong 14.4 \text{ Psi}$

Units of weight - Unità di peso - Gewichtseinheiten  
Unidad de peso - Unités de poids

	N	daN	kN	kg	lbs
1N	1	0,1	0,001	0,102	0,225
1daN	10	1	0,01	1,02	2,25
1kN	1000	100	1	102	225
1kg	9,81	0,981	0,00981	1	2,205

Units of torque - Unità di coppia - Drehmomenteinheiten  
Unidad de par - Unités de couple

	Nm	daNm	kNm	kgm	lb-in
1Nm	1	0,1	0,001	0,102	8,854
1daNm	10	1	0,01	1,02	88,54
1kNm	1000	100	1	102	8854
1kgm	9,81	0,981	0,00981	1	86,8
1lb-in	0,1129	0,01129	0,0001129	0,01152	1

**TIGHTENING TORQUES - COPPIE DI SERRAGGIO - ANZIEHDREHMOMENTE  
PARES DE TORSION - COUPLES DE SERRAGE**

Unit - Unità di misura - Maßeinheiten - Unidad de medida - Unités de mesure: Nm

SIZE OF BOLT MISURA VITE SCHRAUBENMASS TAMAÑO TORNILLO MESURE VIS		TYPE OF BOLT - TIPO VITE - GEWINDE - TIPO DE TORNILLO - TYPE DE VIS					
		8.8		10.9		12.9	
		Normali	Normali + Loctite 270	Normali	Normali + Loctite 270	Normali	Normali + Loctite 270
COARSE PITCH - PASSO GROSSO - GROßER SCHRITT - PASO GRUESO - GROS PAS	M6 x 1	9,5-10,5	10,5-11,5	14,3-15,7	15,2-16,8	16,2-17,8	18,1-20,0
	M8 x 1,25	23,8-26,2	25,6-28,4	34,2-37,8	36,7-40,5	39,0-43,0	43,7-48,3
	M10 x 1,5	48-53	52-58	68-75	73-81	80-88	88-97
	M12 x 1,75	82-91	90-100	116-128	126-139	139-153	152-168
	M14 x 2	129-143	143-158	182-202	200-221	221-244	238-263
	M16 x 2	200-221	219-242	283-312	309-341	337-373	371-410
	M18 x 2,5	276-305	299-331	390-431	428-473	466-515	509-562
	M20 x 2,5	390-431	428-473	553-611	603-667	660-730	722-798
	M22 x 2,5	523-578	575-635	746-824	817-903	893-987	974-1076
	M24 x 3	675-746	732-809	950-1050	1040-1150	1140-1260	1240-1370
FINE PITCH - PASSO FINE - KLEINER SCHRITT PASO FINO - PAS FIN	M8 x 1	25,7-28,3	27,5-30,5	36,2-39,8	40,0-44,0	42,8-47,2	47,5-52,5
	M10 x 1,25	49,4-54,6	55,2-61,0	71,5-78,5	78,0-86,0	86,0-94,0	93,0-103,0
	M12 x 1,25	90-100	98-109	128-142	139-154	152-168	166-184
	M12 x 1,5	86-95	94-104	120-132	133-147	143-158	159-175
	M14 x 1,5	143-158	157-173	200-222	219-242	238-263	261-289
	M16 x 1,5	214-236	233-257	302-334	333-368	361-399	394-436
	M18 x 1,5	312-345	342-378	442-489	485-536	527-583	580-641
	M20 x 1,5	437-483	475-525	613-677	674-745	736-814	808-893
	M22 x 1,5	581-642	637-704	822-908	903-998	998-1103	1078-1191
	M24 x 2	741-819	808-893	1045-1155	1140-1260	1235-1365	1363-1507
M27 x 2	1083-1197	1178-1302	1520-1680	1672-1848	1834-2027	2000-2210	
M30 x 2	1511-1670	1648-1822	2138-2363	2332-2577	2565-2835	2788-3082	

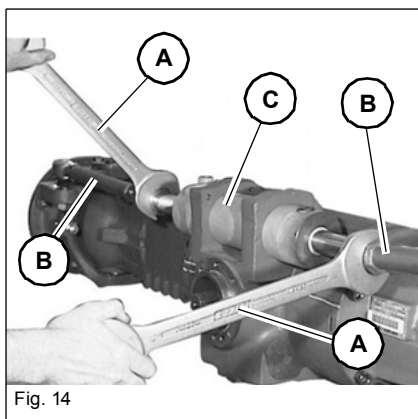

5. If the track setting is not correct:  
use 2 wrenches **A** on the steering cylinder **C** to screw the track rods **B** in or out until the track setting is correctly adjusted.

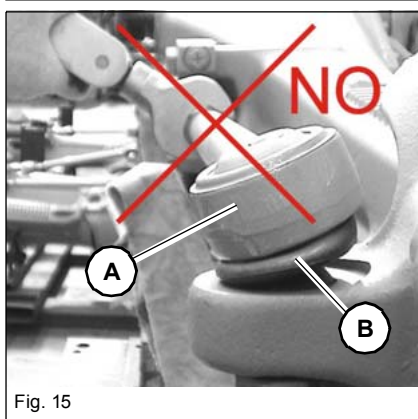

**NOTICE**

Damage to the seal **B** on the track rod head **A** due to incorrect assembly!

- Use a wrench to hold the track rod head **A** in position.

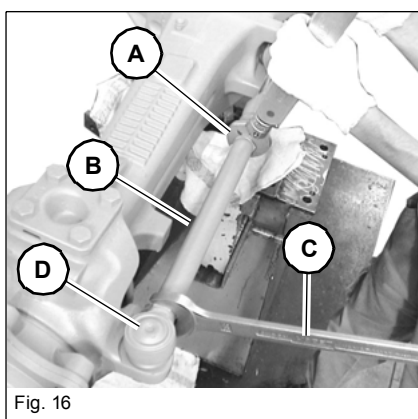

6. Hold the track rod head **D** in position and prevent it from being turned with a wrench **C** .  
7. Tighten the net **A** on the track rod **B**.

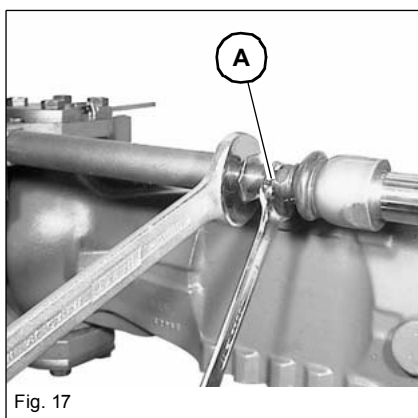

8. After adjusting the track, tighten the locknut **A** to 250 Nm (184 lbf.ft).

Remove/install intermediate gearbox



**Information**

**Before starting work, take safety and instructions into consideration**

- see "Notes on the repair manual" on page E-1,
- see "Safety instructions" on page E-5,
- see "Maintenance preparations, instructions" on page 1-1!

**Preparing work**

Tools:

- Movable car jack, load-bearing capacity min. 5000 kg (11,023 lb)
- 2x axle stands, load-bearing capacity of min. 5000 kg (11,023 lb)
- Suitable lifting gear, minimum load-bearing capacity 5000 kg (11,020 lb)
- Suitable slings (cables and shackles) with corresponding load-bearing capacity
- Suitable receptacle for the hydraulic oil/gearbox oil
- Plugs (different sizes) for closing the oil lines
- Special tools

**Technical data**

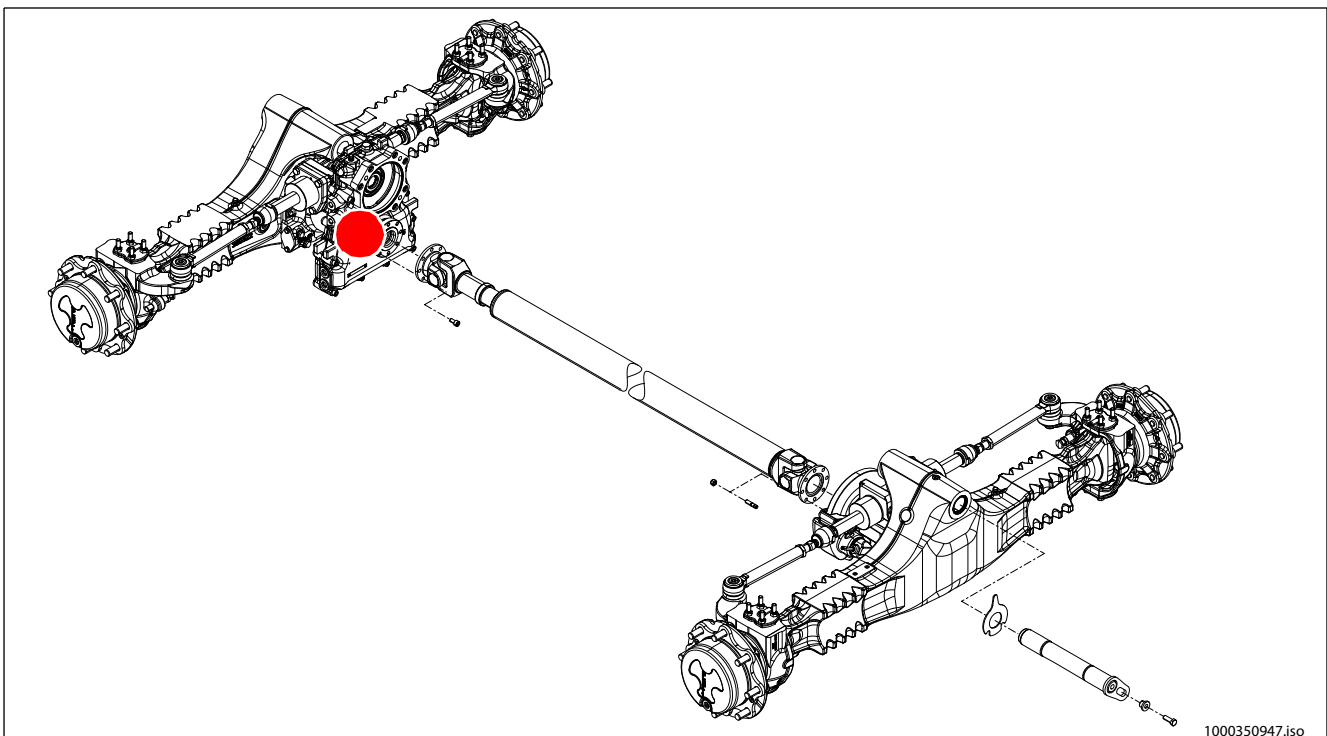

1000350947.iso

Weight	BMK	Remark/designation
14.3 kg (31.5 lb)		Gearbox housing (at the cardan shaft)
16.1 kg (35.4 lb)		Gearbox housing (at the axle)
For non-specified tightening torques, see chapter "Introduction/tightening torques"		

Completely remove/install the differential housing



**Information**

**Before starting work, take safety and instructions into consideration**

- see "Notes on the repair manual" on page E-1,
- see "Safety instructions" on page E-5,
- see "Maintenance preparations, instructions" on page 1-1!

**Preparing work**

Tools:

- Movable car jack, load-bearing capacity min. 5000 kg (11,023 lb)
- 2x axle stands, load-bearing capacity of min. 5000 kg (11,023 lb)
- Suitable lifting gear, minimum load-bearing capacity 5000 kg (11,020 lb)
- Suitable slings (cables and shackles) with corresponding load-bearing capacity
- Suitable receptacle for the hydraulic oil/gearbox oil
- Plugs (different sizes) for closing the oil lines
- Special tools

**Technical data**

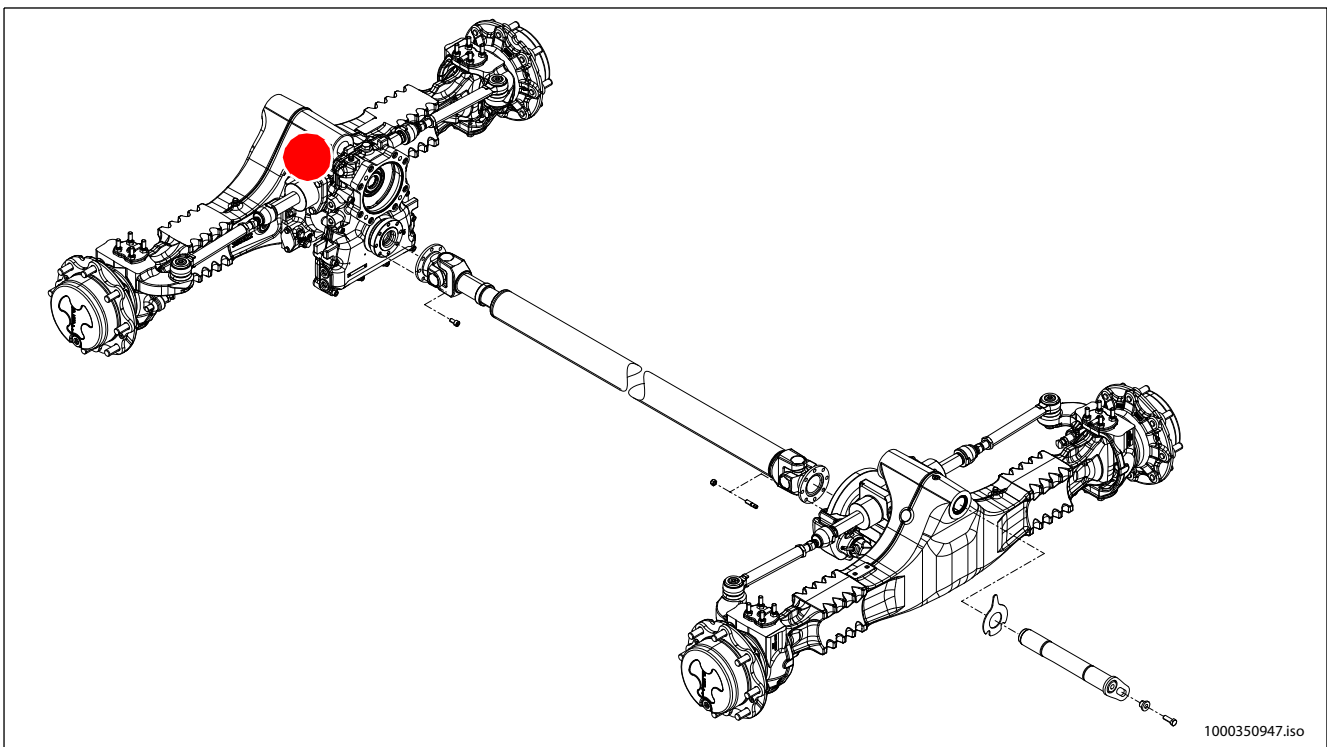

Weight	BMK	Remark/designation
		Differential housing
For non-specified tightening torques, see chapter "Introduction/tightening torques"		

#### Replacing the angle drive

1. Insert 4x new pins **I** in the differential cage with some grease.

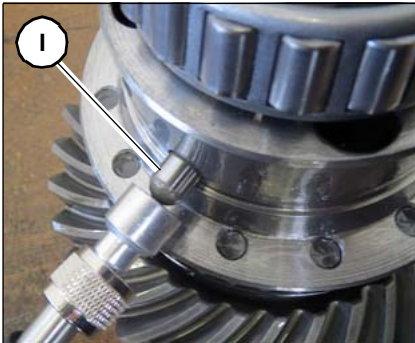

Fig. 95

2. Slide on the shifting collar **H** of the differential lock.

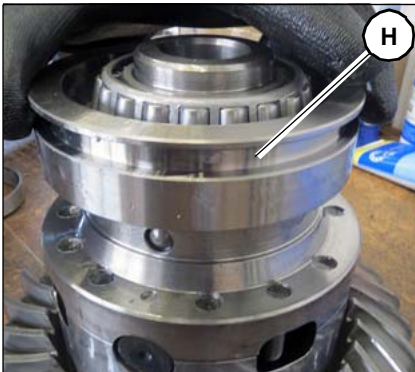

Fig. 96

3. Lift the angle drive **G** into the differential housing and push all the way onto the input bevel gear **J**.

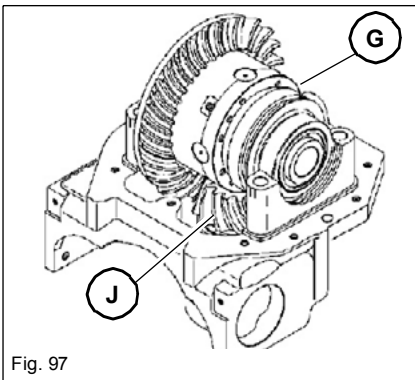

Fig. 97

4. Attach the bearing shell **B** and **C** while noting the markings.

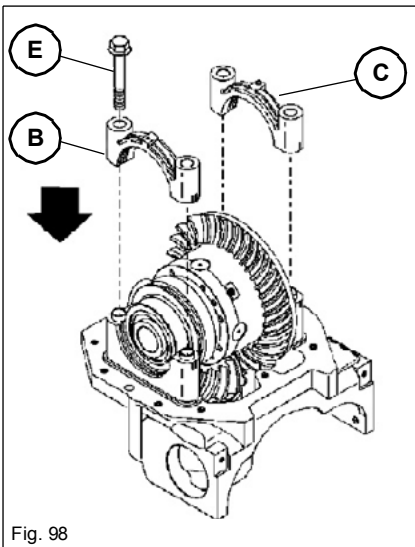

Fig. 98

#### **NOTICE**

The fitted sleeves must fit precisely with the bores.

► In no case assemble the bearing shells with a hammer.

5. Mount the screws **E** to the bearing shells and tighten to 266 Nm (196 lbf.ft).

## 5 Axles

### Front axle, Remove/install input bevel gear



WACKER  
NEUSON

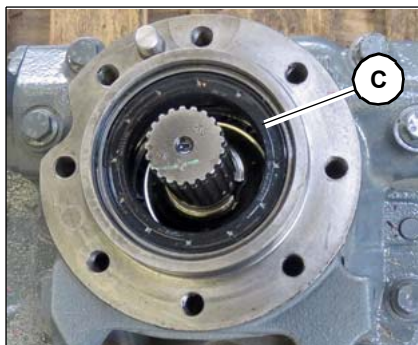

Fig. 128

21. Press in a new shaft sealing ring **C** with a special tool [1000285517](#).

22. Lightly grease the shaft sealing ring **C**.

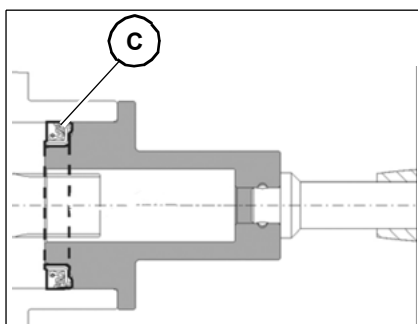

Fig. 129

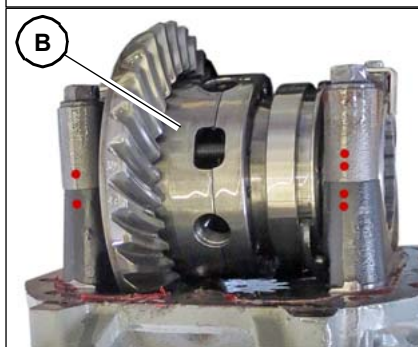

Fig. 130

23. Install the angle drive **B** – see *"Replacing the angle drive" on page 5-30*.

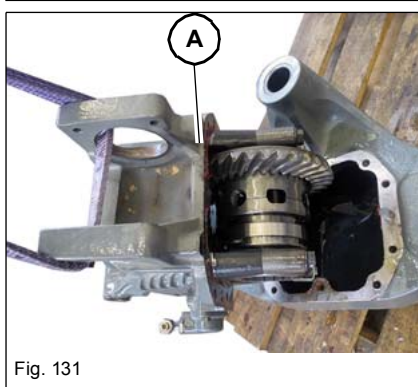

Fig. 131

24. Install the differential housing **A** – see *"Install the differential housing" on page 5-23*.

#### Seal-tighten cylinder

At the differential housing on the right (as seen in the travel direction):

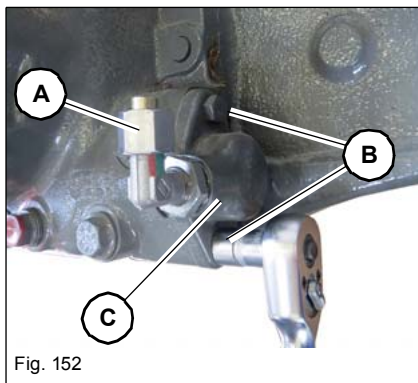

Fig. 152

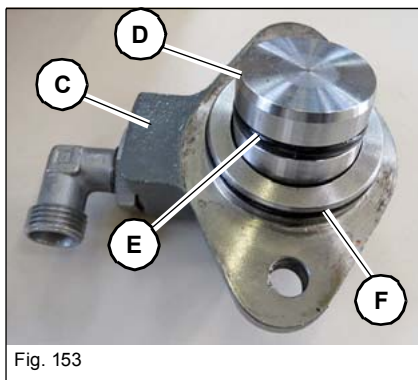

Fig. 153

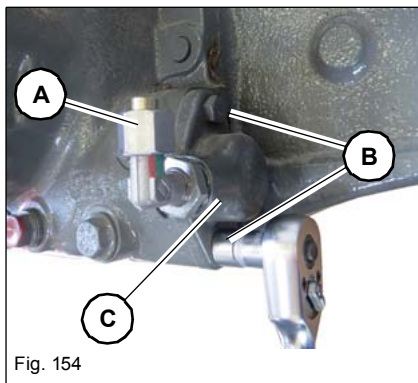

Fig. 154

1. Unscrew the hose pipe **A** and oil seal on both sides.
2. Unscrew the screws **B** and loosen and remove the cylinder **C**.

3. Pull the piston **D** out of the cylinder **C**.
4. Clean the sealing surfaces at the cylinder **C** and differential housing.
5. Replace the O-ring **E** and lightly grease.
6. Replace the O-ring **F** and lightly grease.
7. Insert the piston **D** into the cylinder **C**.

8. Position the cylinder **C** and mount the screws **B** and tighten to 27.6 Nm (20 lbf.ft).
9. Mount the hose pipe **A** and tighten.

#### Finishing work

10. Fill axle with oil – see ["Change oil at the differential lock \(front axle\)" on page 1-118](#)
11. Mount the underride protection – see ["Remove/install underride protection \(closed\)" on page 12-12](#).
12. Switch on battery master switch **S008** – see ["Battery master switch S008" on page 1-4](#).
13. Make a test run.
14. Take note of any leaks, chafing or kinking points and see to it all parts are fastened correctly.

## 5 Axles

### Completely remove/install the rear axle



WACKER  
NEUSON

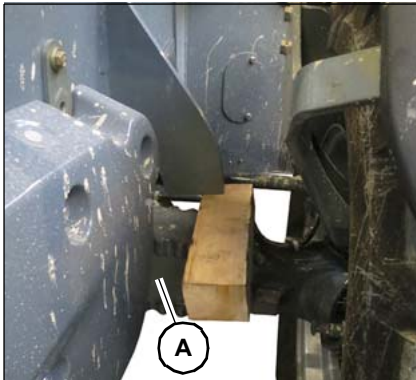

Fig. 183

37. Remove the safeguard against uncontrolled movement of the oscillating axle **A**.

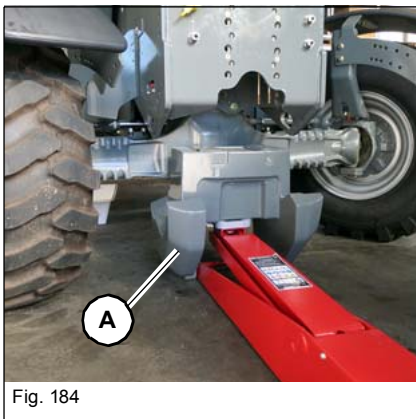

Fig. 184

38. Lift ballast weight **A** using a suitable car jack centrally under the frame.

39. Mount nuts on ballast weight **A**.

40. Remove car-hitch – see ["Install" on page 17-4](#).

41. Fill axle with oil – see ["Change oil in differential \(rear axle\)" on page 1-116](#).

42. Mount cardan shaft from rear axle – see ["Install" on page 4-18](#).

43. Mount the underride protection – see ["Remove/install underride protection \(closed\)" on page 12-12](#).

44. Switch on battery master switch **S008** – see ["Battery master switch S008" on page 1-4](#).

45. Vent brake – see ["Change and vent the brake fluid" on page 1-124](#).

CLICK HERE TO **DOWNLOAD** THE COMPLETE MANUAL

- Thank you very much for reading the preview of the manual.
- You can download the complete manual from: [www.heydownloads.com](http://www.heydownloads.com) by clicking the link below



- Please note: If there is no response to CLICKING the link, please download this PDF first and then click on it.

CLICK HERE TO **DOWNLOAD** THE COMPLETE MANUAL

## 5 Axles

### Rear axle, Completely remove/install the differential housing



WACKER  
NEUSON

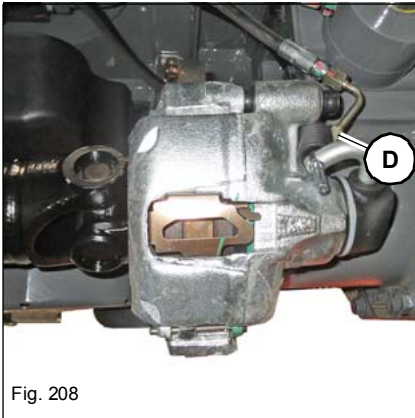

At the brake caliper:  
14. Mount the brake hose **D**.

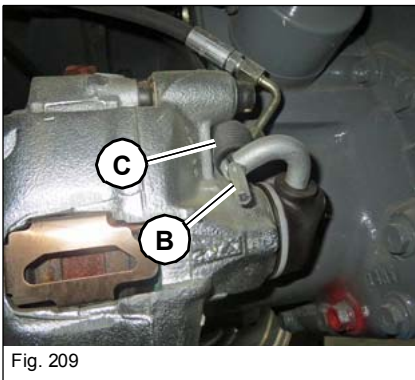

15. Slide in the hand brake cable **B** into the brake caliper.  
16. Push the rubber grommet **C** over the hand brake cable **B**.  
17. Hook up the hand brake cable **B** at the brake caliper.

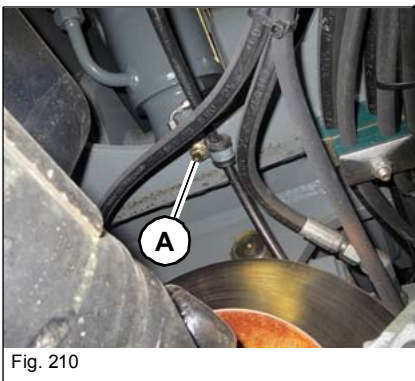

18. Mount the clamp **A** of the hand brake cable via the brake disc at the frame.

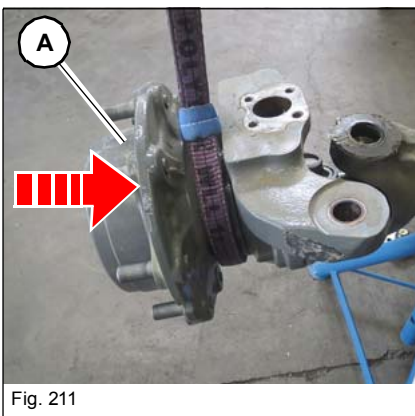

19. Install the planetary drive **A** – see ["Installing the planetary drive" on page 5-81](#).

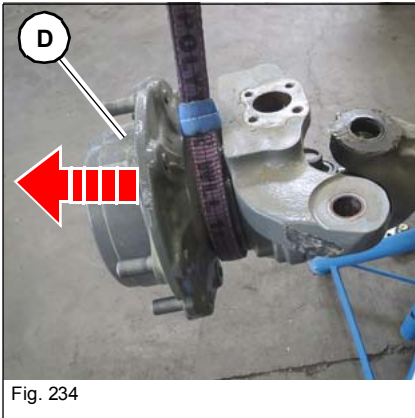

18. Carefully (if possible horizontally) pull the planetary drive **D** with double cardan shaft out of the axle body.

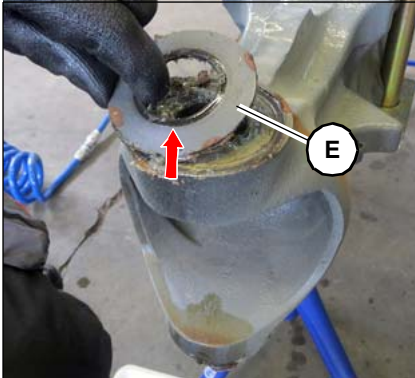

Fig. 262

7. Position the washer above **E** and washer below **F** with grease.
8. Check for the correct position of the washer above **E** and washer below **F**.

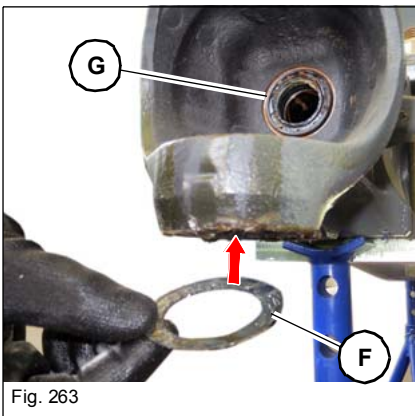

Fig. 263

9. Check the radial sealing ring **G** for damage and replace if necessary – see *"Change the shaft sealing ring in the axle tube"* on page 5-111.
10. Lightly grease the radial sealing ring **G**.

**! WARNING**

**Risk of injury lifting heavy components.**

Death or serious injury.

- ▶ Use lifting gear of sufficient lifting capacity.
- ▶ Use functionally safe lifting gear.
- ▶ Use lifting gear on firm and level ground.
- ▶ Move the lifting tackle to predefined or suitable position on the component

**NOTICE**

Damage to the radial sealing ring.

- ▶ Insert the planetary drive into the axle body, horizontally if possible.

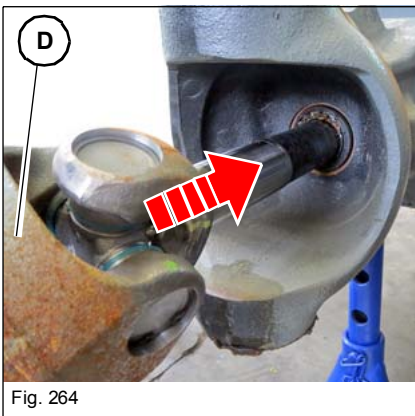

Fig. 264

11. Carefully insert the planetary drive **D** with double cardan shaft into the axle body.

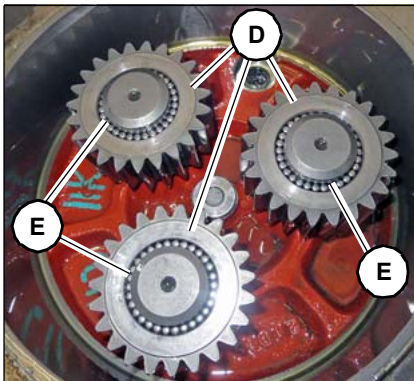

Fig. 284

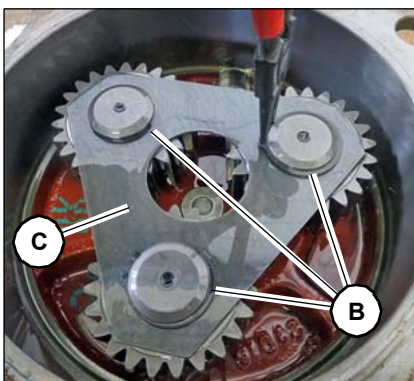

Fig. 285

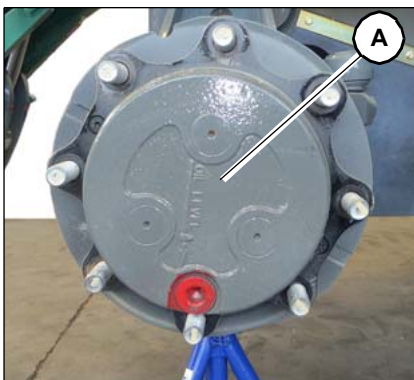

Fig. 286



Fig. 287

### Install the needle bearings

1. Clean the housing and all individual parts.

### NOTICE

Ensure a dust-free and clean environment.

2. Attach 3x gear wheels **D**.
3. Insert the new needle bearings **E** (30 individual needles per gear wheel) between the gear wheel and shaft with grease.
4. Attach the thrust washer **C**.
5. Mount 3x retaining rings **B**.
6. Mount the cover of the planetary drive – see ["Installing the cover" on page 5-95](#).
7. Refill oil – see ["Checking/refilling oil at the planetary drives" on page 1-119](#).
8. Mount the wheel – see ["Mounting the wheels" on page 1-130](#).
9. Remove the support underneath the vehicle.
10. Slowly lower the vehicle with the hydraulic jack.
11. Switch on battery master switch **S008** – see ["Battery master switch S008" on page 1-4](#).

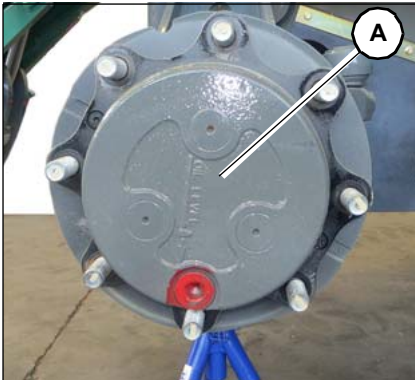

Fig. 311



Fig. 312

8. Mount the cover of the planetary drive – see *"Installing the cover"* on page 5-95.

9. Refill oil – see *"Checking/refilling oil at the planetary drives"* on page 1-119.

10. Mount the wheel – see *"Mounting the wheels"* on page 1-130.

11. Remove the support underneath the vehicle.

12. Slowly lower the vehicle with the hydraulic jack.

13. Switch on battery master switch **S008** – see *"Battery master switch S008"* on page 1-4.

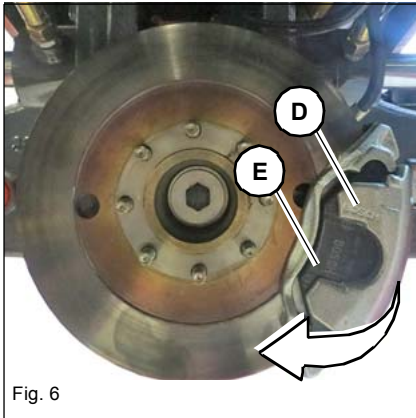

- 12. Insert new brake pads **E**.
- 13. Fold down the brake caliper **D**.

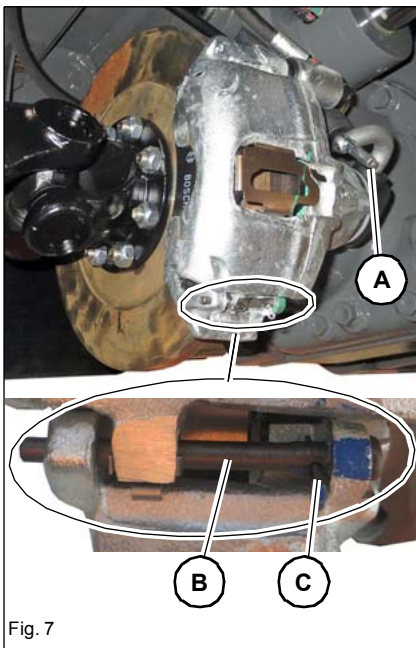

- 14. Insert bearing bolt **B**.
- 15. Attach lock pin **C**.
- 16. Hook up wire rope **A** on brake calliper.
- 17. [Adjusting the parking brake on page 6-26.](#)
- 18. Check fill level in expansion tank.

## 6.4 Brake disk

### Remove/install the brake disk



#### Information

The safety and preparation instructions are to be taken into consideration before starting work

- see "Notes on the repair manual" on page E-1,
- see "Safety instructions" on page E-5,
- see "Maintenance preparations, instructions" on page 1-1!

#### Preparing work

Tools:

- Suitable receptacle for collecting the brake fluid
- Plugs (different sizes) for closing the brake lines

#### Technical data

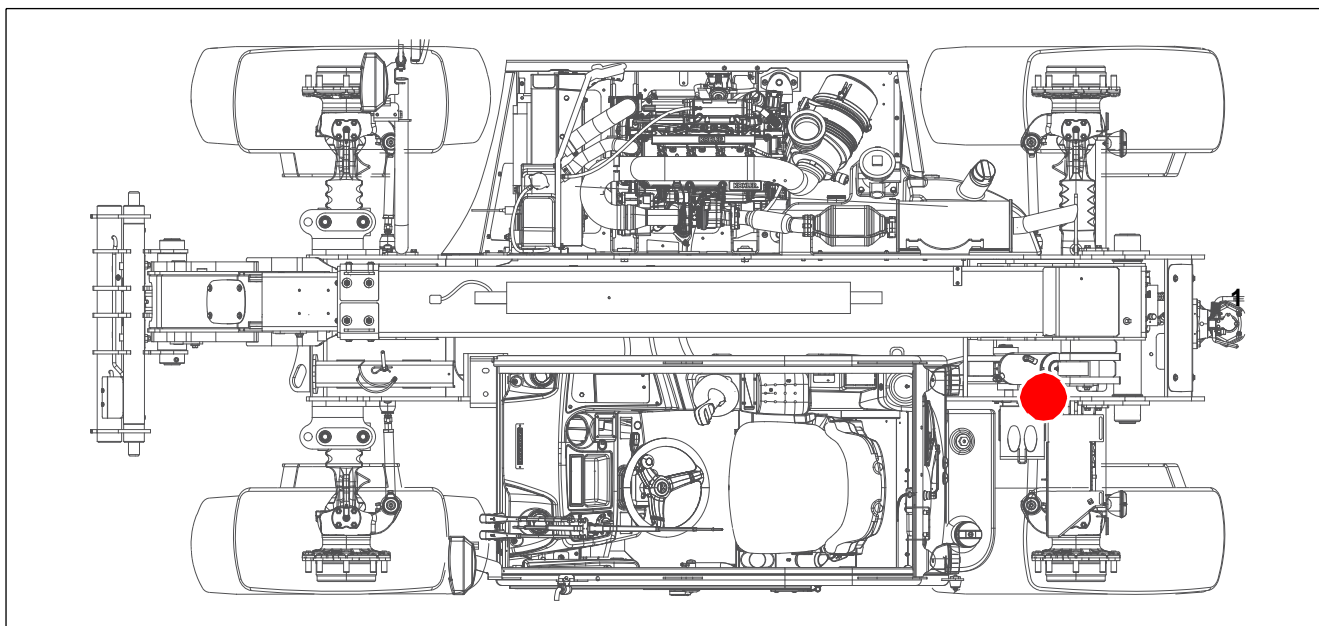

Weight	BMK	Remark/designation
		Brake disk
For non-specified tightening torques, see chapter "Introduction/tightening torques"		



#### Environment

Use a suitable container to collect the brake fluid as it drains and dispose of it in an environmentally friendly manner!

## Adjusting the parking brake

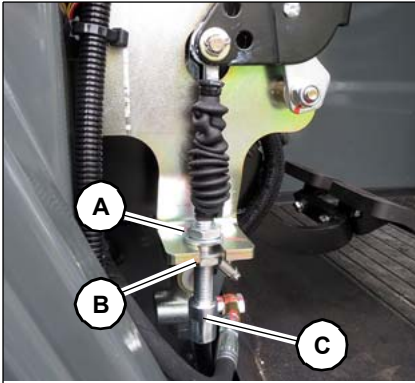

Fig. 51

1. Loosen locknut **A**.
2. Use the nut **B**, adjust the length of the wire rope **C** so that the parking brake starts to close after 3 to 5 settings.
3. Tighten locknut **A**
4. Insert cladding under steering wheel – see *"Install" on page 12-20*.
5. Add foot mat.
6. Switch on battery master switch **S008** – see *"Switch on battery master switch S008" on page 1-4*.



## Bleed/synchronize steering

---



### Information

Ensure that there is no air in the steering circuit otherwise synchronization cannot be checked or set correctly!

---

1. Ventilate and synchronize steering; to do so, in all-wheel steering and at low speed, turn the steering wheel all the way to the **left or right** and try in each direction to briefly continue turning against the pressure at the end position – *see System Handbook!*
2. Synchronization with front axle and diagonal steering – *see System Handbook!*
3. Adjust control pressure – *see System Handbook!*

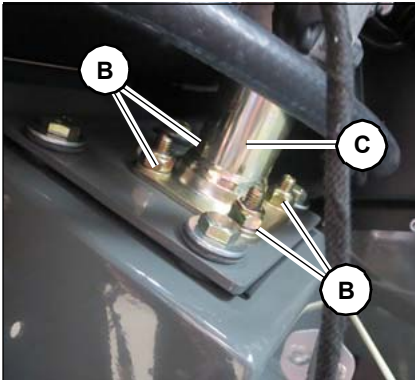

Fig. 37

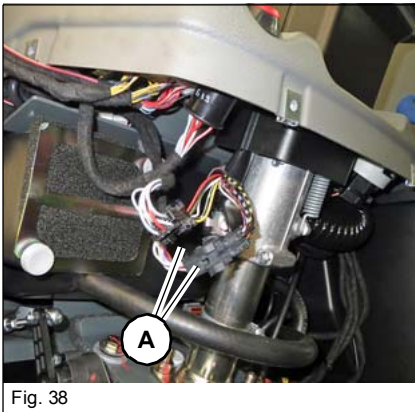

Fig. 38

### Install

1. Lift up the steering column **C** from the top.
2. Place the steering column **C** on the steering unit gearing with slight steering movements.
3. Mount the 4 **B** nuts at the bottom of steering column **C** and tighten to 46 Nm (34 lbf.ft).
4. Connect the plug connections **A** on the steering column switch.
5. Fit cladding under the instrument panel – see ["Install" on page 12-20](#).
6. Switch on battery master switch **S008** – see ["Switch on battery master switch S008" on page 1-4](#).

## Disassemble

### WARNING

**Contact with hot liquids and machine components!**

Death or serious injury due to skin burns.

- ▶ Wear suitable protective clothing.
- ▶ Let liquids and the diesel engine cool down.
- ▶ Observe instructions.

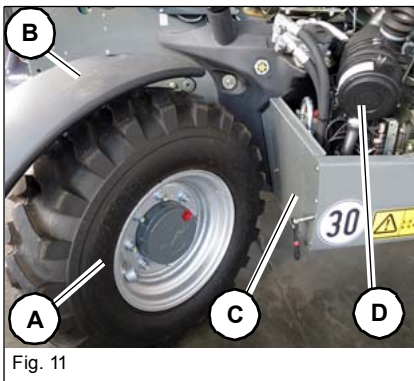

1. Switch off battery master switch **S008** – see ["Switch off the battery master switch S008" on page 1-4.](#)
2. Remove underride protection – see ["Remove" on page 12-10.](#)
3. Open the engine cover – see ["Opening the engine cover" on page 1-22.](#)
4. Carefully support rear axle and unscrew wheel **A**.
5. Unscrew wheel cover **B** with bracket.
6. Remove maintenance cover **C** from the engine vat, rear – see ["Open the maintenance access" on page 1-23.](#)
7. Completely empty the hydraulic oil tank **XX** – see ["Changing hydraulic oil" on page 1-89,](#) work steps 7 to 13.
8. Remove air filter **D** – see ["Disassemble" on page 2-53.](#)

On hydraulic tank, bottom:

9. Mark all the positions of the hoses.
10. Remove the cable ties.
11. Loosen clamps **A** and remove suction hose **B** from tank.

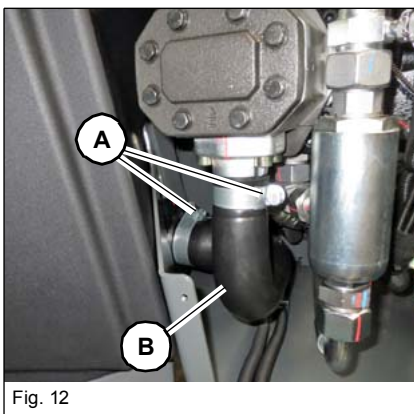

12. If available, pull out cable **C** of the oil pre-heater.

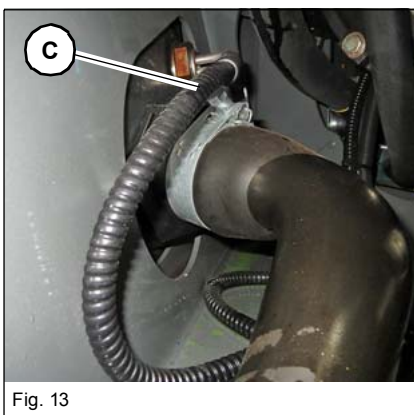

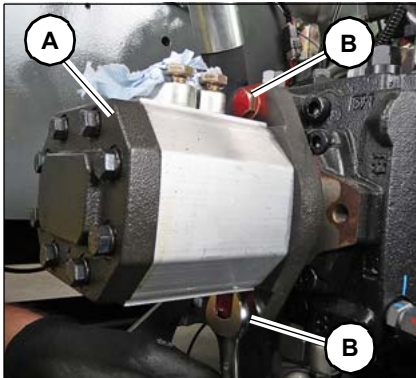

Fig. 32

Fastening working hydraulics gear pump:

12. Remove screws **B**.

13. Remove the gear pump **A** from the variable displacement pump **VII**.

### Install

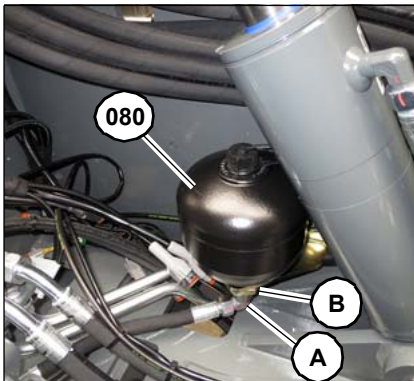

Fig. 44

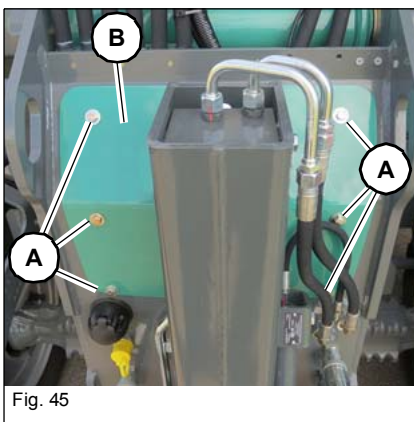
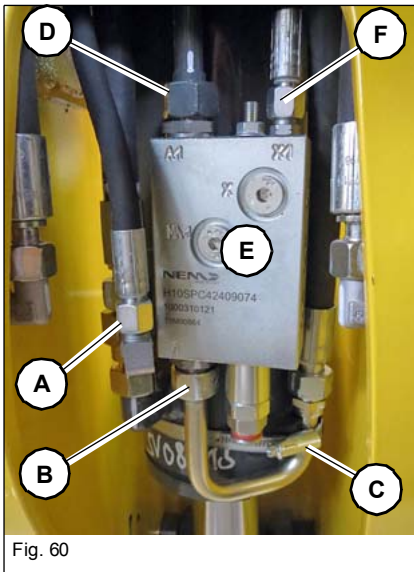

Fig. 45

1. Position pressure accumulator **080** and tighten fastening nuts **B** to 50 Nm.
2. Position hose and tighten sleeve nut **C**.
3. Position cover **B** and tighten **A** screws using washers.
4. Add hydraulic oil – see ["Adding hydraulic oil" on page 1-88](#).
5. Switch on battery master switch **S008** – see ["Battery master switch S008" on page 1-4](#).
6. Check the system for correct function and sealing



### Install

1. Screw in all threaded fittings on the vice.
2. Position flexible line and tighten sleeve nut **F** to 28 Nm (21 lbf.ft).
3. Position the hose burst valve **E** on the screw fitting **D**.
4. Tighten sleeve nut **D** to 80 Nm (59 lbf.ft).
5. Position flexible line and tighten sleeve nut **B** to 60 Nm (44 lbf.ft).
6. Mount hose strap **C** and pull tight.
7. Position flexible line and tighten sleeve nut **A** to 28 Nm (21 lbf.ft).
8. Clean all hydraulic connections and ports.
9. Switch on battery master switch **S008** – see ["Battery master switch S008" on page 1-4](#).
10. Tilt the tilt ram **087** in and out several times completely.
11. Check oil level – see ["Checking the hydraulic oil level" on page 1-87](#) and top up if necessary – see ["Adding hydraulic oil" on page 1-88](#).
12. Check the system for correct function and sealing.

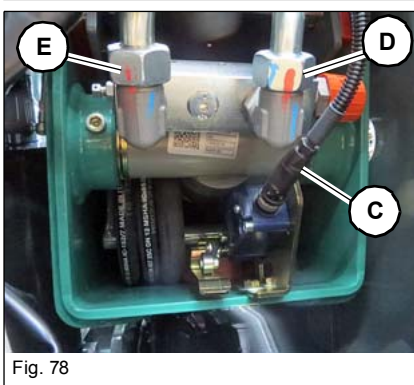
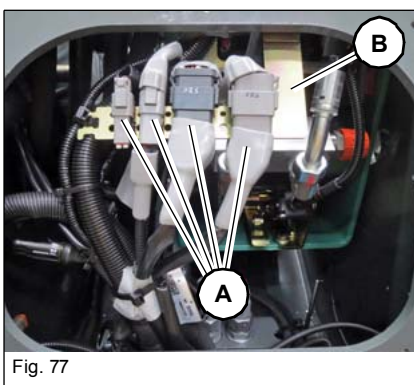
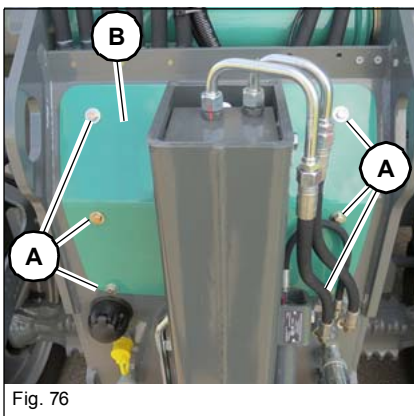
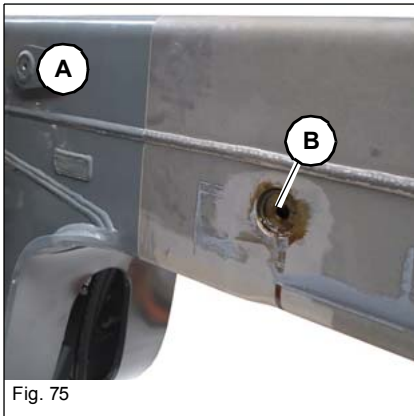

### Disassemble

1. Extend boom **A** until bolt **B** in the push-out cylinder **089** is visible.
2. Release the pressure in the hydraulic system. To do this:
  - Stop the engine, but leave the ignition switched on.
  - Keep emergency lowering switch held down.
  - Move the control lever (joystick) in all directions repeatedly
3. Switch off the starter and remove the starting key.
4. Switch off battery master switch **S008** – see ["Battery master switch S008" on page 1-4.](#)

5. If present, remove autohitch – see ["Disassemble" on page 17-2.](#)
6. Remove screws **A**.
7. Remove cladding **B**.

8. Open the cover – see ["Rear of machine" on page 1-23.](#)
9. If present, remove autohitch – see ["Disassemble" on page 17-2.](#)
10. Detach and unplug plug connections **A** on the bracket **B**.
11. Remove holder **B**.

12. Disconnect plug **C** on the sensor.
13. Loosen screw fixtures **D** and remove hose.
14. Loosen screw fixtures **E** and remove hose.
15. Seal hose pipes and fittings with dummy plugs.

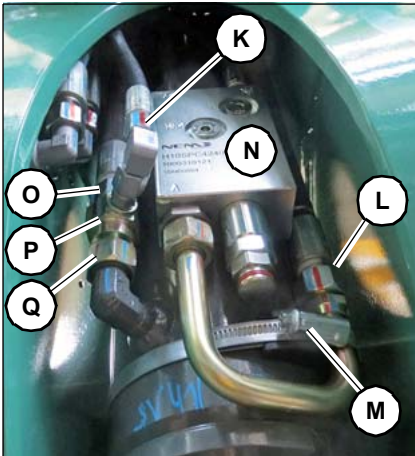

Fig. 100

Hose pipes to the tilt cylinder:

12. Loosen sleeve nut **K** and remove hose pipe.
13. Dismantle hose strap **M**.
14. Loosen sleeve nut **L** and remove hose pipe.
15. Loosen sleeve nut **Q** and remove hose pipe with fitting **P**.
16. Unscrew fitting **P** on the hose pipe **O**.
17. Seal hoses with filler plugs.



### Environment

Use a suitable container to collect the fluids as they drain and dispose of them in an environmentally friendly manner!

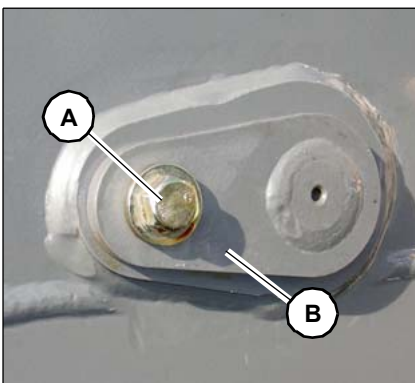

Fig. 101

18. Remove lock screw **A** from the pin **B**.

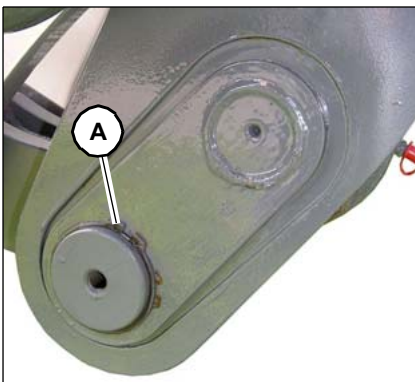

Fig. 102

19. Remove circlip **A** from right-hand side.

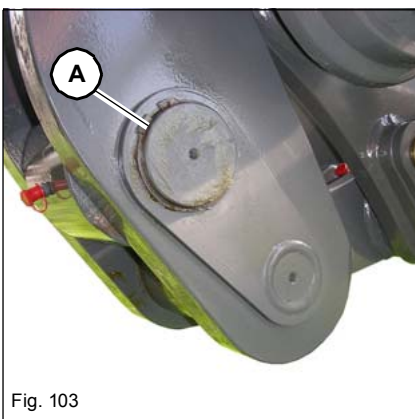

Fig. 103

20. Remove circlip **A** from left-hand side.

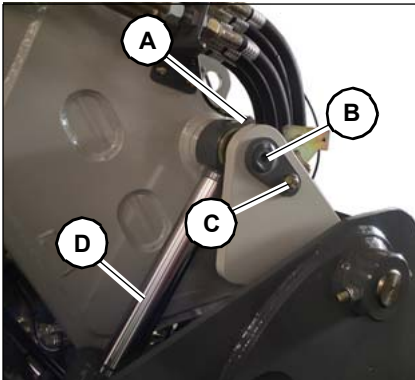

Fig. 122

16. Hook up the compensation cylinder **C 086** to suitable lifting tackle.
17. Loosen the screw connection **A** and remove the lubricating line.
18. Remove lock screw **C** and bushing.
19. Drive out the bolt **B** in the boom with a slide hammer-puller.

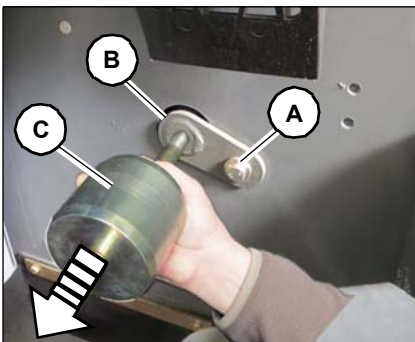

Fig. 123

20. Remove lock screw **A** and bushing.
21. Drive out bolt **B** on frame with a slide hammer-puller **C**.
22. Lift out the compensation cylinder **086** from the frame with lifting tackle.

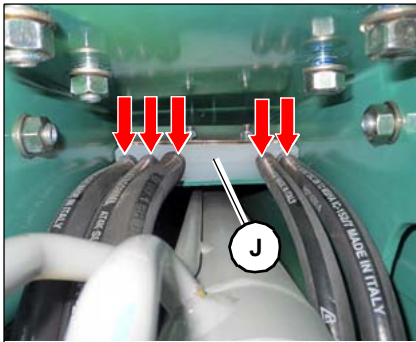

Fig. 143

33. Mark the positions of the hose pipes on the hose clamp **J**.

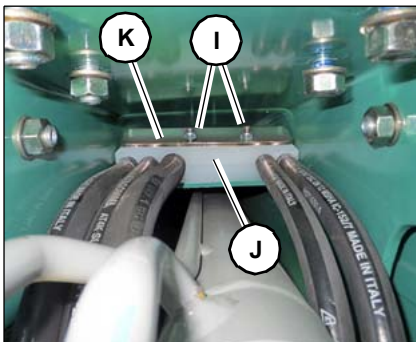

Fig. 144

34. Remove nuts **I** on the hose clamp **J**.

35. Remove hose clamp **J** with cover plate **K**.

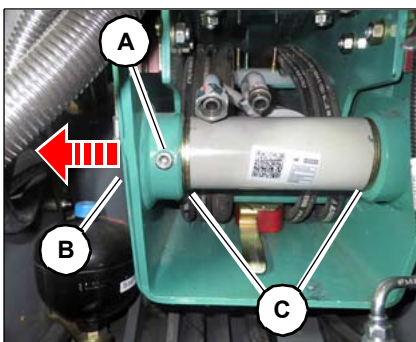

Fig. 145

36. Remove lock screw **A**.

37. Drive out pins **B** to the left.

38. Remove the washers **C**.

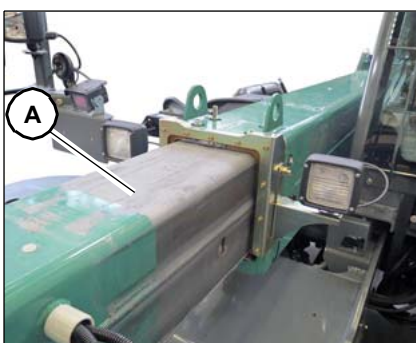
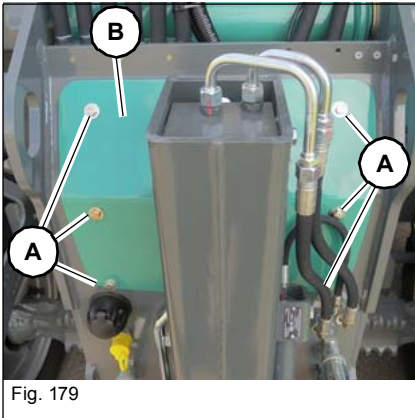

Fig. 146

39. Pull out the inner pipe about 0.5 m (1.64 ft).



44. Position the cover **B** and fasten it with screws **A**.

45. Check oil level – see ["Checking the hydraulic oil level"](#) on page 1-87 and top up if necessary – see ["Adding hydraulic oil"](#) on page 1-88.

## 8.15 Tilt rod and rocker arm

### Removing/installing the tilt rod

**i** Information

The safety and preparation instructions are to be taken into consideration before starting work

- see "Notes on the repair manual" on page E-1,
- see "Safety instructions" on page E-5,
- see "Maintenance preparations, instructions" on page 1-1!

#### Preparing work

Tools:

- Jack stands

#### Technical data

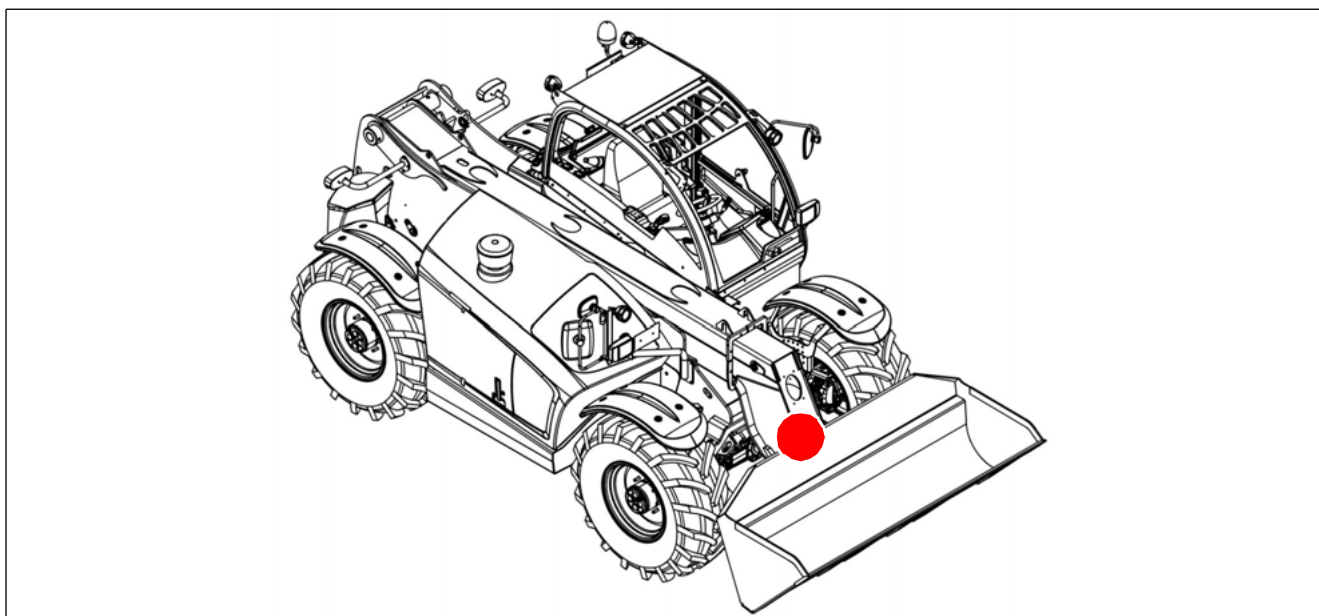

Weight	BMK	Remark/designation
7.3 kg (16.1 lb)		Tilt rod
For non-specified tightening torques, see chapter "Introduction/tightening torques"		

## 8.16 Quickhitch

### Removing/installing the quickhitch

#### Information

**The safety and preparation instructions are to be taken into consideration before starting work**

- see "Notes on the repair manual" on page E-1,
- see "Safety instructions" on page E-5,
- see "Maintenance preparations, instructions" on page 1-1!

#### Preparing work

Tools:

- Suitable lifting gear, minimum load-bearing capacity 500 kg (1,100 lb)
- Suitable slings (cables and shackles) with corresponding load-bearing capacity
- Jack stands
- Suitable receptacle for collecting the hydraulic oil
- Plugs (different sizes) for closing the oil lines

#### Technical data

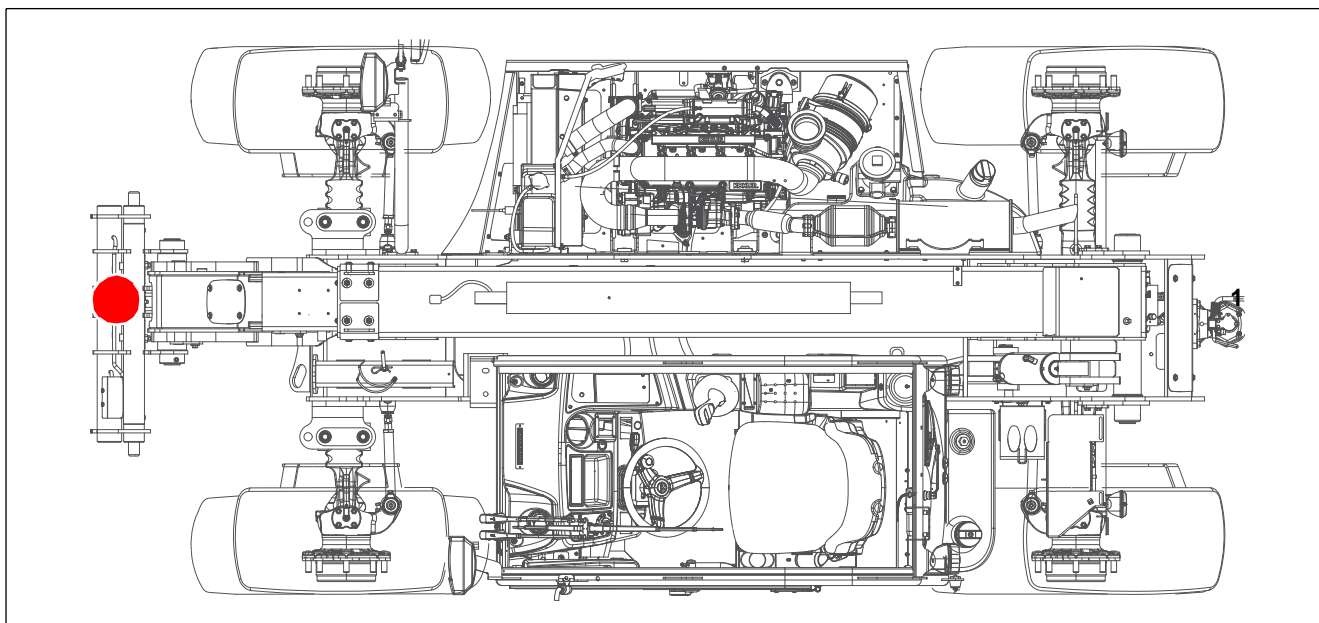

Weight	BMK	Remark/designation
116 kg (256 lb)	091	Quickhitch
For non-specified tightening torques, see chapter "Introduction/tightening torques"		

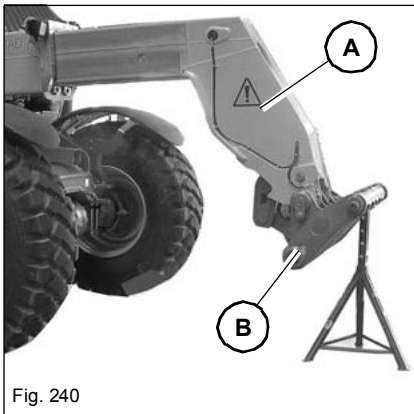

**Disassemble**

1. Place the telehandler on a firm and level surface
2. Apply the parking brake.
3. Expand telescopic boom **A** by about 200 mm (7.87 in).
4. Move the quickhitch facility **B** into the position shown.
5. Place telescopic boom on to a support making sure that no pressure is applied.
6. Release the pressure in the hydraulic system. To do this:
  - Stop the engine, but leave the ignition switched on.
  - Keep emergency lowering switch held down.
  - Move the control lever (joystick) in all directions repeatedly
7. Switch off the starter and remove the starting key.
8. Switch off battery master switch **S008** – see ["Battery master switch S008" on page 1-4.](#)
9. Unscrew maintenance cover **A** on the telescopic boom.

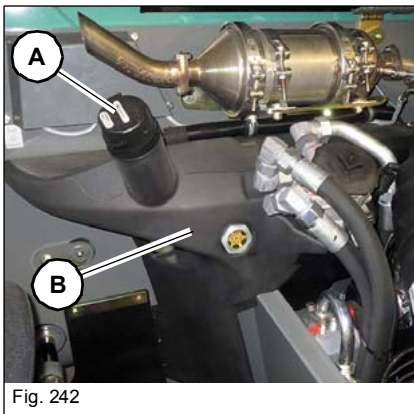
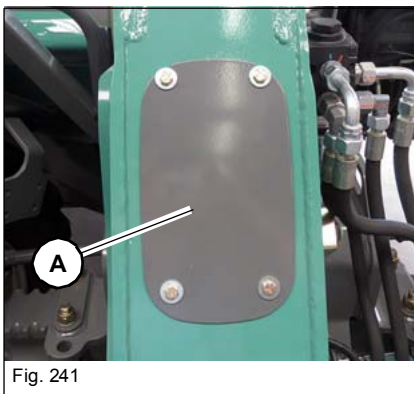

10. Dismantle vent filter **A** on hydraulic tank **B** in order to vent any overpressure in the tank.
11. Connect vacuum pump to the opening of the vent filter **A** and place the hydraulic tank **B** under vacuum.

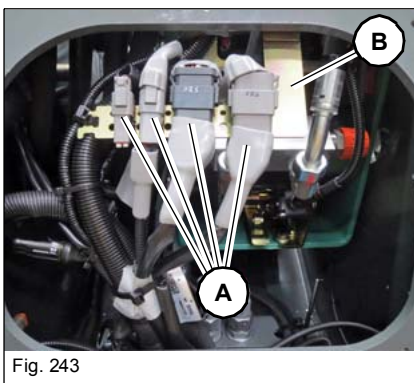

12. Open the cover – see ["Rear of machine" on page 1-23.](#)
13. If present, remove autohitch – see ["Disassemble" on page 17-2.](#)
14. Detach and unplug plug connections **A** on the bracket **B**.
15. Remove holder **B**.

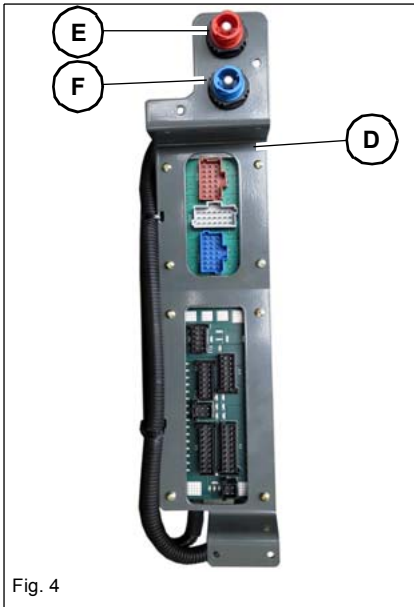

Fig. 4

9. Mark all connector positions on the back of the board **C**.
10. Take off all plugs.
11. Disconnect plug **E** (power supply +, bayonet fitting).
12. Disconnect plug **F** (ground -, bayonet fitting).
13. Take out boards with support **D**.

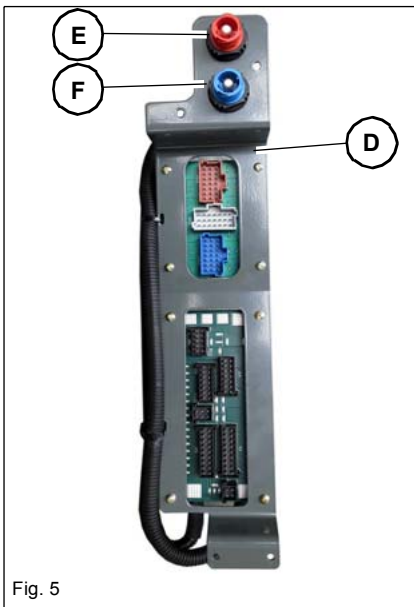

Fig. 5

### Install

1. Position boards with support **D**.
2. Insert plug **E** (power supply +, bayonet fitting).
3. Insert plug **F** (ground -, bayonet fitting).
4. Insert all connections into the positions marked on the back.

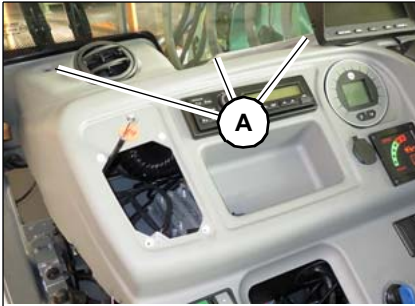

Fig. 26

20. Mount screws **A** on the instrument panel, front.



Fig. 27

21. Position rotary switch of the cabin heater at the rear of the instrument panel and tighten nut to rotary switch **B**.

22. Attach rotary switch **B**.

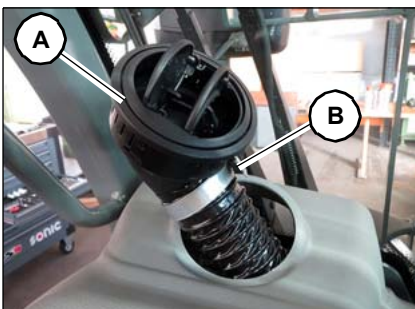

Fig. 28

Heat nozzles:

23. Place heater hoses on the heat nozzles **A**.

24. Tighten hose strap **B** on the heater hoses.

25. Insert heat nozzles **A** on the left and the right.

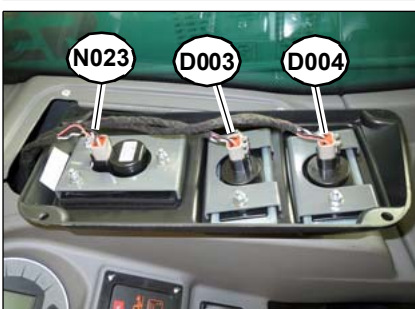

Fig. 29

Operating unit, right:

26. Insert plug **N023** (oil quantity adjustment).

27. Insert plug **D003** (keypad - standard).

28. Insert plug **D004** (keypad - options).

## 9.6 Travel sensor for bucket repositioning B028

### Remove/install travel sensor with rod

**i** Information

The safety and preparation instructions are to be taken into consideration before starting work

- see "Notes on the repair manual" on page E-1,
- see "Safety instructions" on page E-5,
- see "Maintenance preparations, instructions" on page 1-1!

#### Technical data

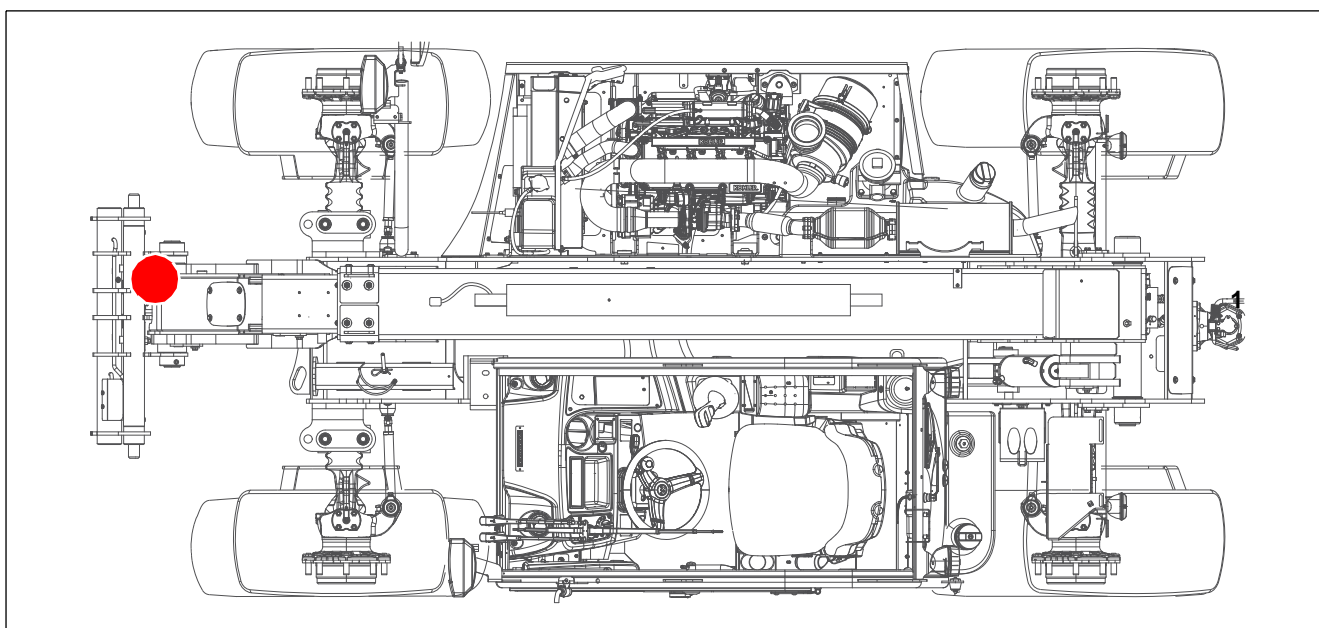

Weight	BMK	Remark/designation
	B028	Position pickup for bucket repositioning

For non-specified tightening torques, see chapter "Introduction/tightening torques"

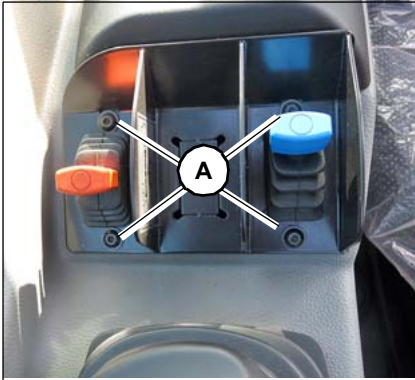

Fig. 63

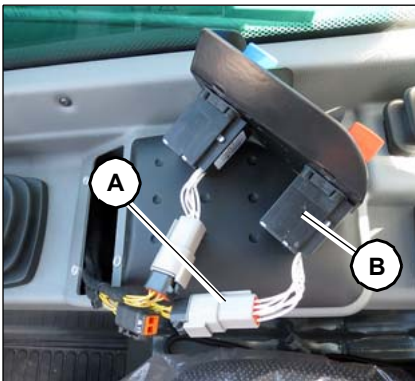

Fig. 64

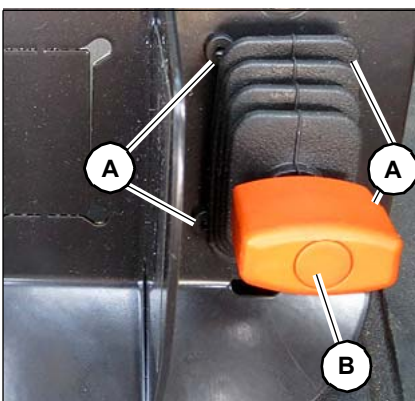

Fig. 65

### Disassemble

1. Switch off battery master switch **S008** – see *"Switch off the battery master switch S008" on page 1-4.*
2. Remove screws **A**.
3. Disconnect connector **A** on hand throttle potentiometer **B R012**.
4. Remove A screws and take out hand throttle potentiometer **B R012**.

## 9.11 Controller

### Removing/installing controller N004

**i** Information

The safety and preparation instructions are to be taken into consideration before starting work

- see "Notes on the repair manual" on page E-1,
- see "Safety instructions" on page E-5,
- see "Maintenance preparations, instructions" on page 1-1!

#### Technical data

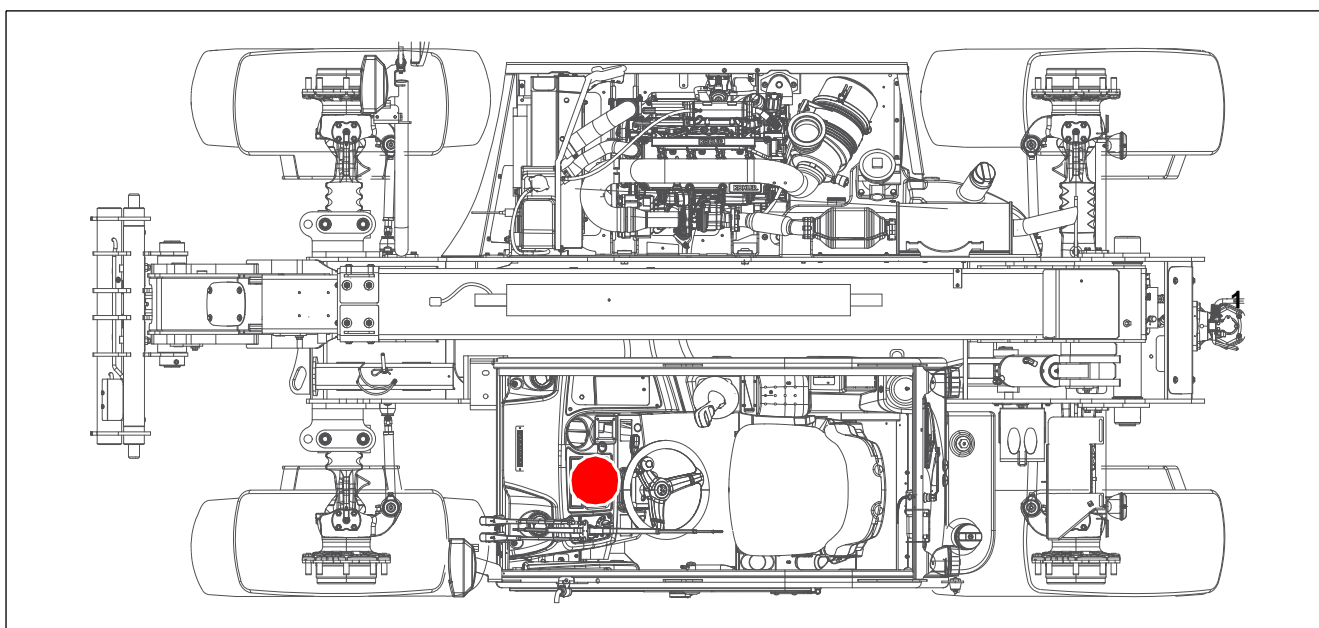

Weight	BMK	Remark/designation
	N004	Controller
For non-specified tightening torques, see chapter "Introduction/tightening torques"		

## 12.2 V-belt cover

### Remove/install V-belt cover

**i** Information

The safety and preparation instructions are to be taken into consideration before starting work

- see "Notes on the repair manual" on page E-1,
- see "Safety instructions" on page E-5,
- see "Maintenance preparations, instructions" on page 1-1!

#### Technical data

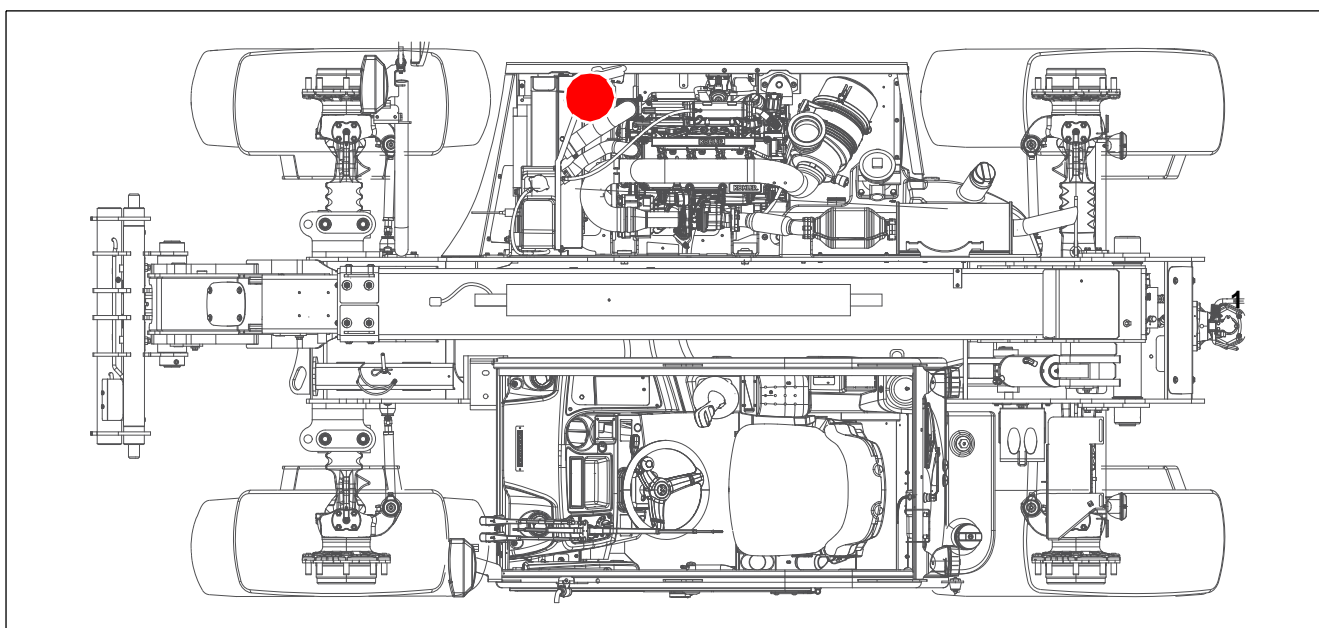

Weight	BMK	Remark/designation
		V-belt cover
For non-specified tightening torques, see chapter "Introduction/tightening torques"		

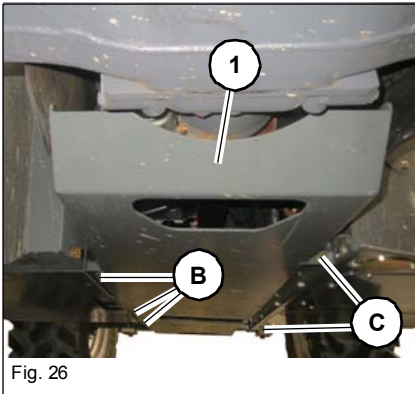

2. Loosen **B** screws on underride protection **1** and fold down underride protection **1**.
3. Hold down the underride protection **1** in position and loosen **C** screws.
4. Put down the underride protection **1**.

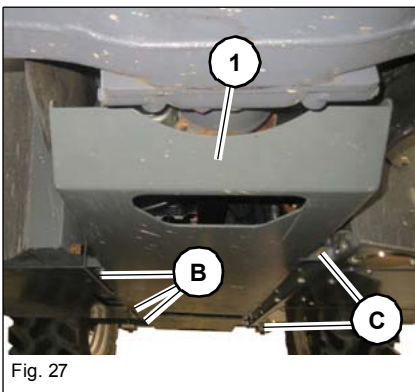

### Install

 **WARNING**

**Risk of injury from the weight of the underride protection!**

Risk of serious injuries in the event of the underride protection folding open by itself.

- ▶ Never mount the underride protection on your own but always with two people.

1. Position underride protection **1** and tighten **C** screws.
2. Fold up underride protection **1** and hold in position.
3. Tighten **B** screws on underride protection **1**.

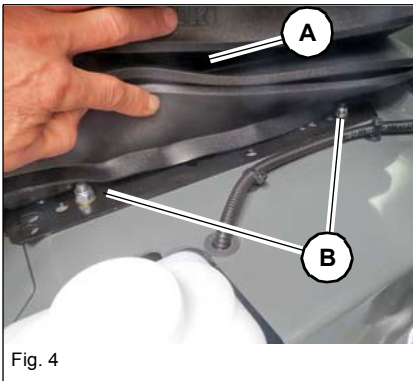

### Install

1. Position operator seat **A** on the cab floor.
2. Tighten nuts **B** underneath bellows **A** of operator seat.

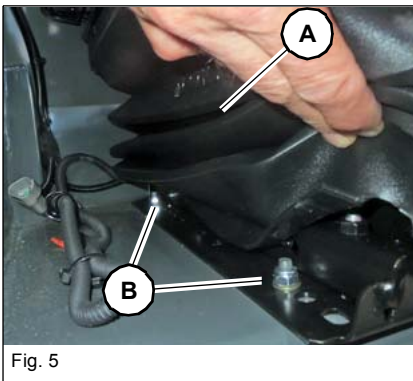

3. Plug in connector **A**.
4. Switch on battery master switch **S008** – see ["Battery master switch S008" on page 1-4](#).

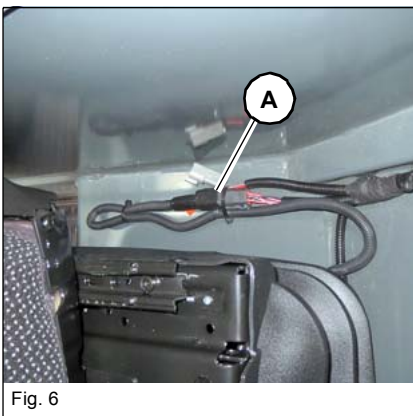

## Install

### **WARNING**

**Risk of injury lifting heavy components.**

Death or serious injury.

- ▶ Use lifting gear of sufficient lifting capacity.
- ▶ Use functionally safe lifting gear.
- ▶ Use lifting gear on firm and level ground.
- ▶ Move the lifting tackle to predefined or suitable position on the component

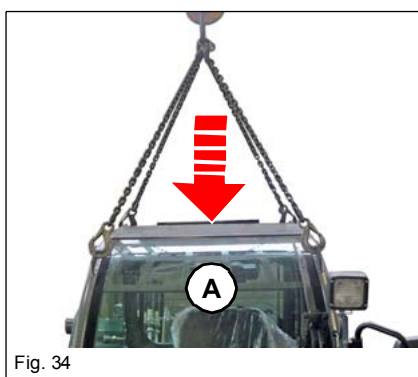

1. Before installation, check the cab bearings, replace cab bearings if necessary – see "Install" on page 14-24.
2. Secure suitable lifting gear on the eyelets of the cab.
3. Carefully lower and position cab **A** on the chassis.

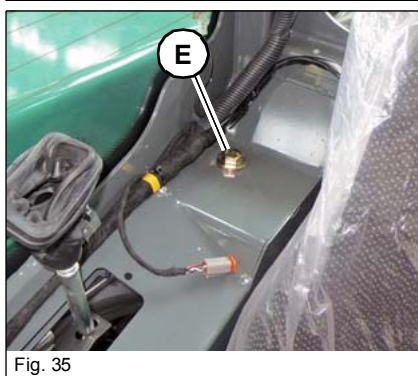

Rear cabin bearings:

4. Insert fastening screw **E** with washer from above and mount the washer and nut from below and tighten with 195 Nm (144 lbf.ft).

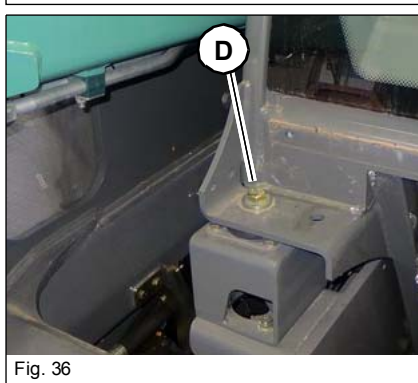

Front cabin bearings:

5. Insert fastening screw **D** with washer from above and mount the washer and nut from below and tighten with 195 Nm (144 lbf.ft).

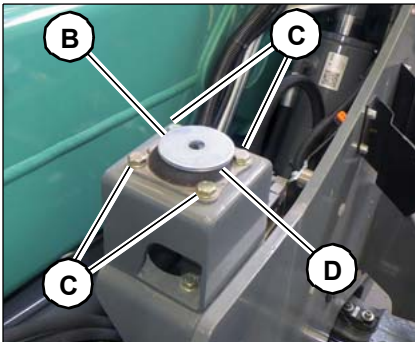

Fig. 65

At the rear of the frame:

14. Remove the washer **B**.

15. Dismount 4x fastening screws **C**.

16. Remove cone bearings **D**.

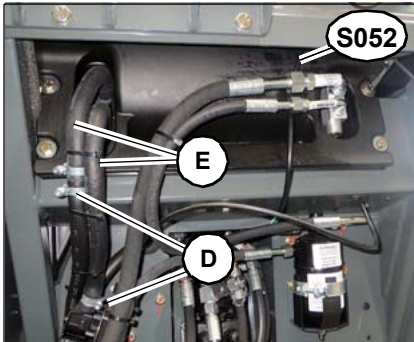

Fig. 21

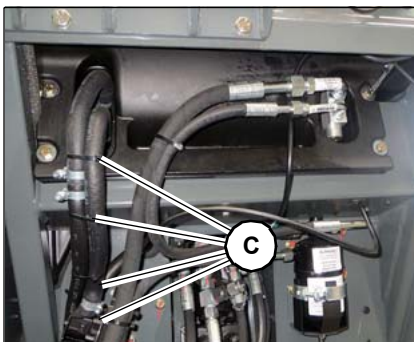

Fig. 22

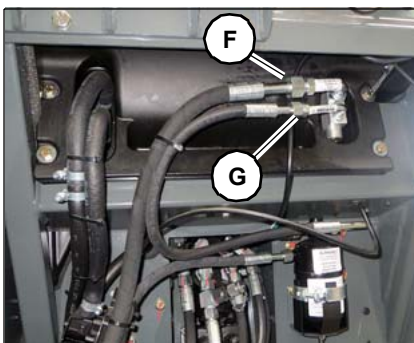

Fig. 23

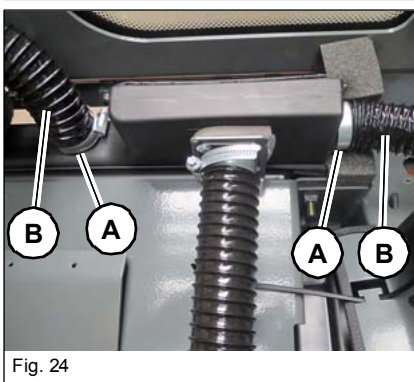

Fig. 24

14. Attach hoses **E**.
15. Tighten clamps **D**.
16. Connect plug connections **S052** on the climatic dryer.

17. Secure coolant hoses with cable binders **C**.

18. Mount hose **F** and hose **G**.

19. Attach heater hoses **B**.
20. Mount clamps **A**.
21. Mount controller N004 – see ["Install" on page 9-45](#).
22. Install the instrument panel – see ["Install" on page 9-12](#).
23. Install the steering column – see ["Install" on page 7-19](#).
24. Install cabin front maintenance cover – see ["Install" on page 15-6](#).
25. Add coolant – see ["Adding coolant" on page 1-67](#).
26. Fill air conditioning system – see ["Filling up the air conditioning system" on page 1-111](#).
27. Switch on battery master switch **S008** – see ["Battery master switch S008" on page 1-4](#).
28. Start the vehicle to warm it up.
29. Set the heating to the highest setting in order to vent the system.
30. Check the coolant level – see ["Checking the coolant level:" on page 1-66](#).

### Disassemble

1. Switch off battery master switch **S008** – see *"Battery master switch S008" on page 1-4.*
2. Remove screws **A**.
3. Remove cladding **B**.

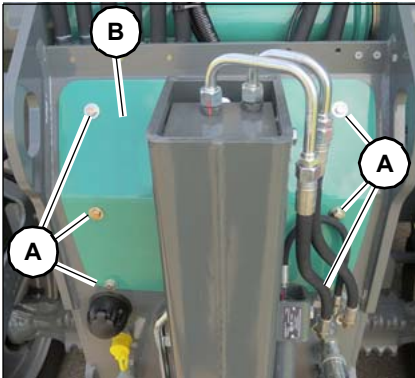

Fig. 2

4. Disconnect sensor cable plug **A**.
5. Remove cable ties **B**.
6. Pull the sensor cable **C** through the connecting plate.

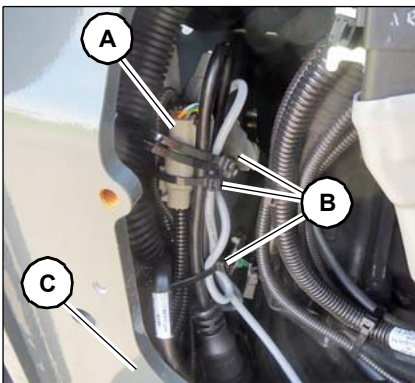

Fig. 3

7. Loosen the screw connections **A**, **B** and **C**.
8. Remove the hydraulic hoses.
9. Seal all openings with plugs.

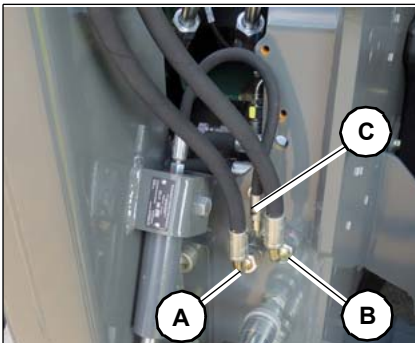

Fig. 4

### Rear hydraulic connections:

10. Remove container for leaked oil **A**.
11. Unscrew hydraulic connection **B**.

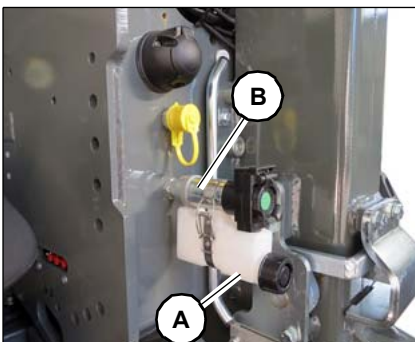
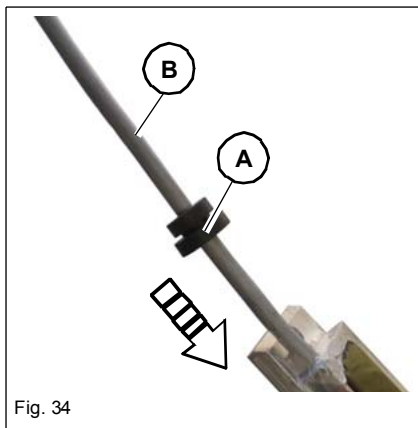
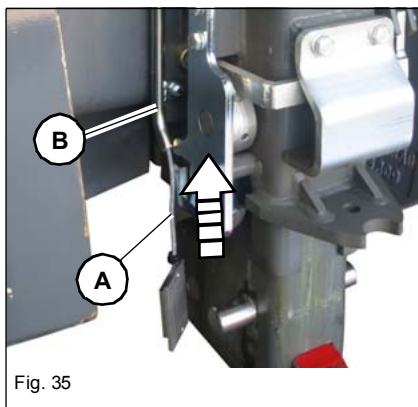

Fig. 5



11. Attach new rubber grommet **A** to the new sensor cable **B**.



12. Pull sensor cable **A** up through the protective tube **B**.

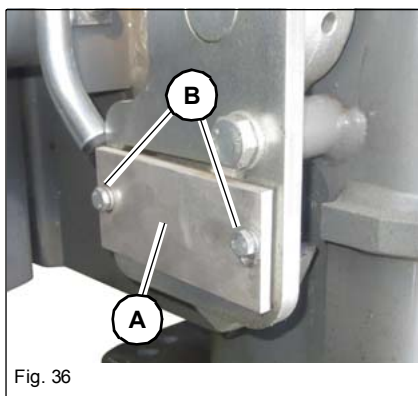

13. Position sensor plate **A** and tighten new screws **B** with new washers.

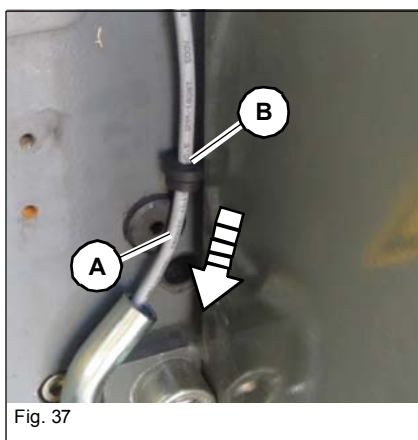

14. Attach new rubber grommet **A** to the sensor cable **B**.

CLICK HERE TO **DOWNLOAD** THE COMPLETE MANUAL

- Thank you very much for reading the preview of the manual.
- You can download the complete manual from: [www.heydownloads.com](http://www.heydownloads.com) by clicking the link below



- Please note: If there is no response to CLICKING the link, please download this PDF first and then click on it.

CLICK HERE TO **DOWNLOAD** THE COMPLETE MANUAL