

SERVICE MANUAL

NO

20NE/20NEP

10NEF/10NEFP

20NEX/20NEXP

NTR30N

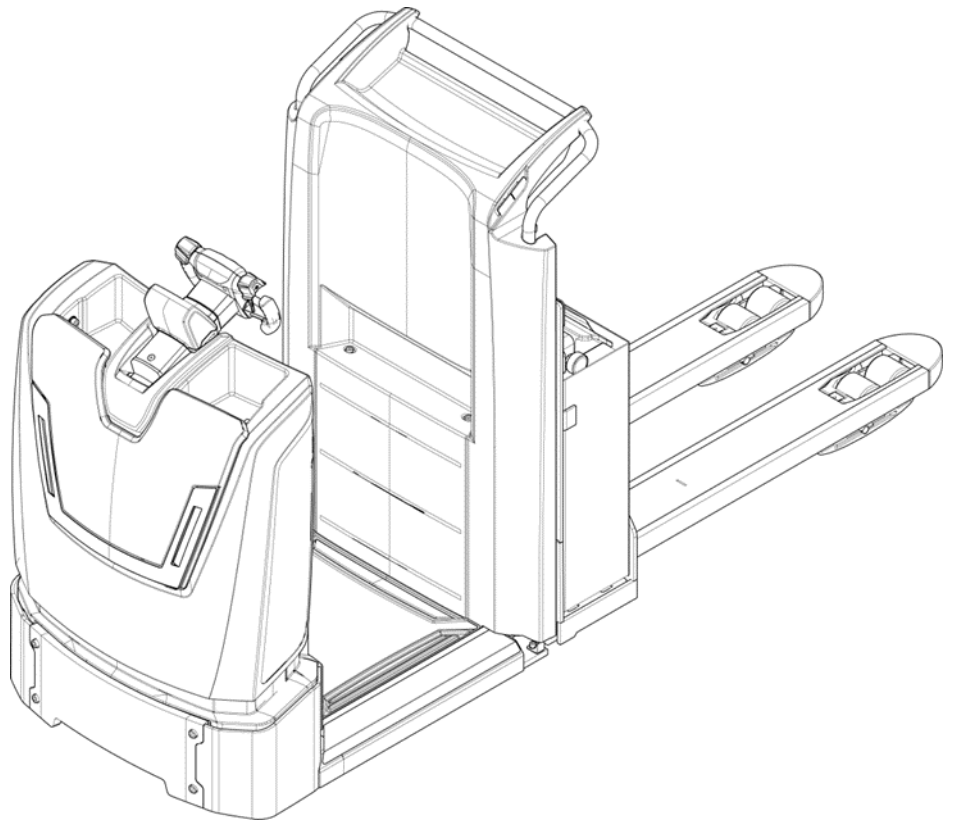

CLICK HERE TO **DOWNLOAD** THE COMPLETE MANUAL

- Thank you very much for reading the preview of the manual.
- You can download the complete manual from: www.heydownloads.com by clicking the link below





- Please note: If there is no response to CLICKING the link, please download this PDF first and then click on it.

CLICK HERE TO **DOWNLOAD** THE COMPLETE MANUAL

2 How to read this manual

2.1 Safety-related signs

The table below includes the safety signs used in this document.

	<p>DANGER indicates a hazard with a high level of risk which, if not avoided, will result in serious injury or death.</p>
	<p>WARNING indicates a hazard with a medium level of risk which, if not avoided, can result in serious injury or death, or damage to your machine.</p>
	<p>CAUTION indicates a hazard with a low level of risk which, if not avoided, can result in minor or moderate injury, or damage to your machine.</p>



NOTE: Notes are used to indicate important information and useful tips.

2.2 Symbols and abbreviations

2.2.1 Safety symbols

Hazard symbols

These symbols indicate a hazardous situation or action. Symbols are used to warn of situations, which can cause environmental damage and personal injury.

General hazard symbol



General warning sign

Hazard symbols



Explosion and fire hazard



Corrosive hazard

4.3 Overview of the truck

4.3.1 Operating position

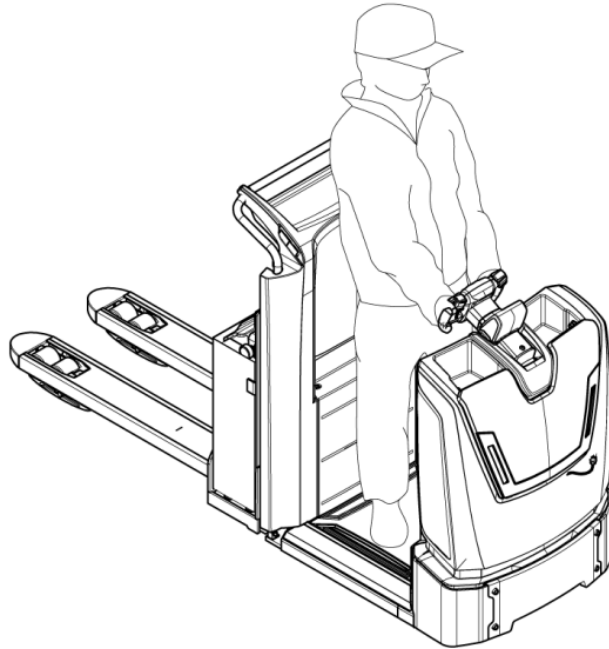

Figure 4. Operating position

To operate the truck in the riding mode, step on the operator's platform and keep your hands on the steering wheel. When you operate the truck, keep your body within the outlines of the truck. Adjust the steering wheel to make your operating position ergonomic.

4.3.2 Operating direction

The operating direction is as follows:

- To go forward, operate the truck to the direction of the steering wheel.
- To go backward, operate the truck in the direction of the forks.

4.3.7.1 Display control buttons

Multifunctional steering wheel display control buttons

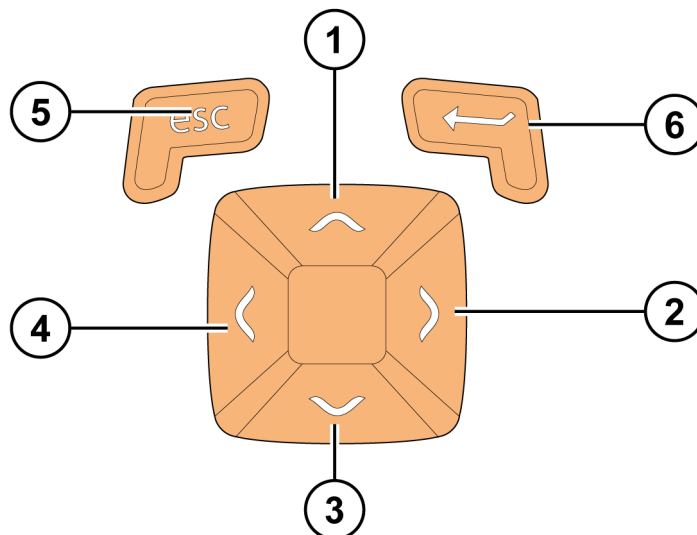

Figure 15. Multifunctional steering wheel display control buttons overview

- | | |
|-------------------------------------|-----------------------------|
| 1. Browse up / PIN code 1 button | 4. Browse left / PIN code 4 |
| 2. Browse right / PIN code 2 button | 5. Exit / Esc button |
| 3. Browse down / PIN code 3 button | 6. Enter button |

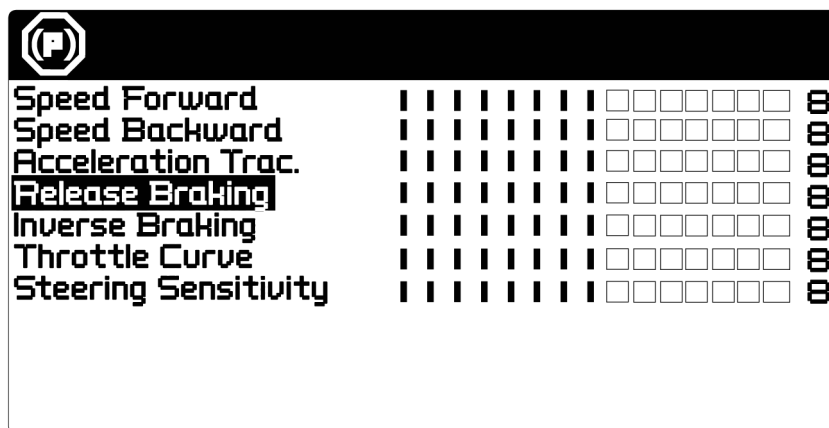

Figure 28. Custom settings

DISPLAY ITEM	DESCRIPTION
Speed forward	The maximum speed when the truck moves to the direction of the truck frame.
Speed backward	The maximum speed when the truck moves to the direction of the forks.
Acceleration	The acceleration time of the truck.
Release braking	The level of the release braking.
Inverse braking	The level of the inverse braking.
Throttle curve	The sensitivity of the accelerator.
Steering sensitivity	The sensitivity of the steering.

5 Mechanical maintenance

5.1 Lifting points

CAUTION



Lift or jack up the truck and put rigid stands or other supports below it.

Apply wheel chocks to the load wheels to make sure that the truck does not move.

5.1.1 Jack points

CAUTION



When you lift the truck up, the lifting carriage rises to the height of 115 mm before the remaining of the truck frame.

Figure 40 below indicates the correct jack points for lifting the truck up for maintenance.

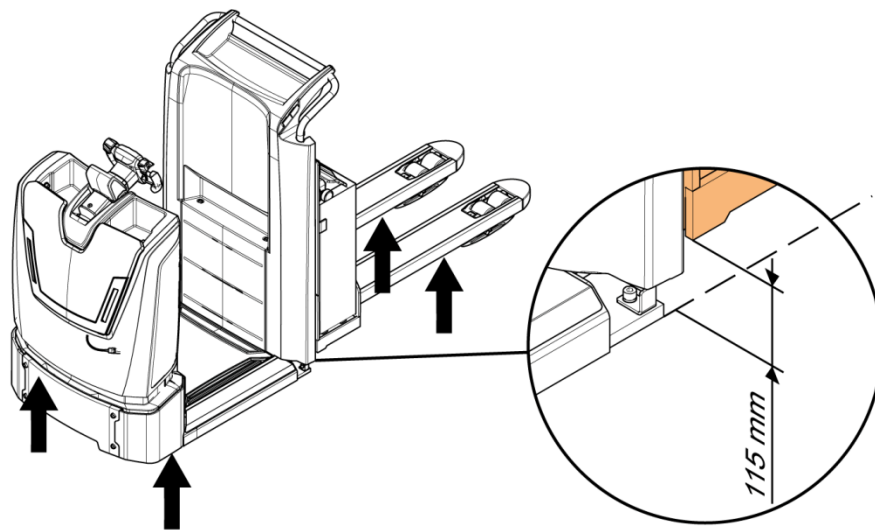

Figure 40. Jack points

5.6 Slewing bearing

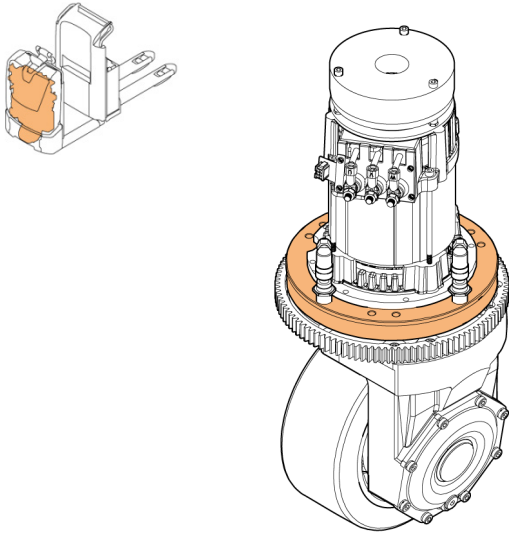

Figure 46. Slewing bearing overview

It is not necessary to replace the slewing bearing lubricant during the lifetime of the truck.

During maintenance:

- Make sure that the bearing turns easily when the traction wheel is lifted up.
- Make sure that the mounting bolts of the drive unit are tightened correctly.

4. Remove the bolt that attaches the castor wheel unit to the truck
5. Remove the castor wheel unit.

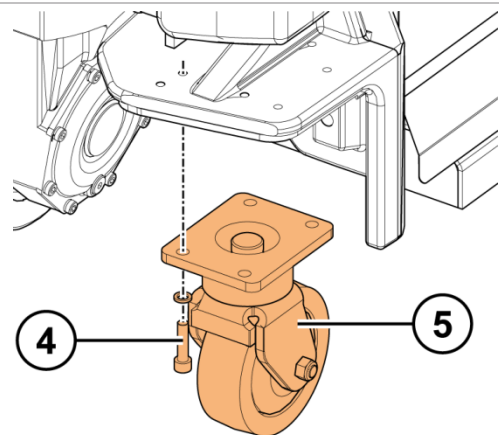

5.10.2 Disassemble the castor wheel

1. Open the nut that holds the castor wheel shaft bolt in the bracket.
2. Remove the shaft that holds the castor wheel in the bracket.
3. Remove the bearing.
4. Remove the castor wheel from the bracket.

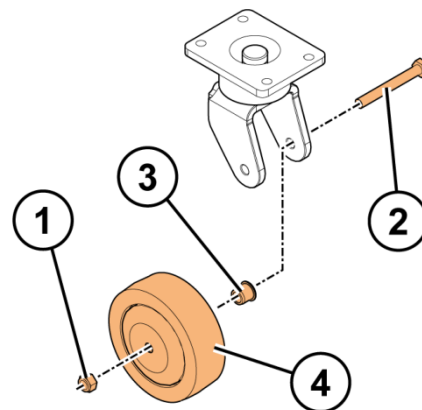

5.10.3 Assemble the castor wheel

1. Put the castor wheel into the bracket.
2. Push the bolt through the bracket and the castor wheel.
3. Install and tighten the nut to the bolt.
4. Make sure that the castor wheel turns properly.



NOTE: If your truck has the 1,150 mm forks and a battery type 12/3 EPzS 375, which is the smallest battery type, you must insert shim plates between the truck and the castor wheel bracket to make the truck more stable. The total thickness of the shim plates that you must insert is 4.5 mm.

4. Remove the circlip from the shaft.
5. Remove the shaft.

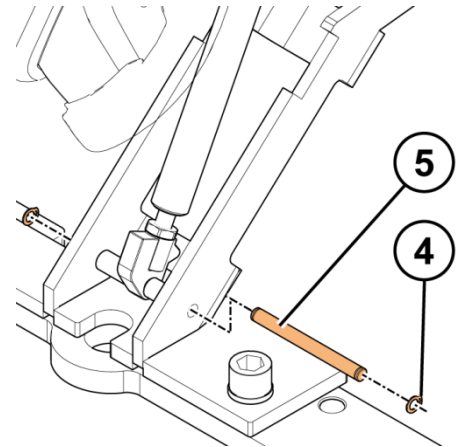

6. Remove the circlip from the top of the gas spring.
7. Release the top of the gas spring.
8. Remove the gas spring.

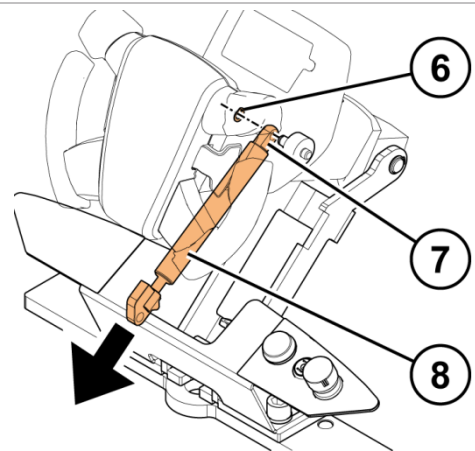

5.13.9 Replace the accelerator

1. Remove the 2 screws on top of the control switch panel.
2. Remove the control switch panel.
3. Disconnect the wire of the accelerator.

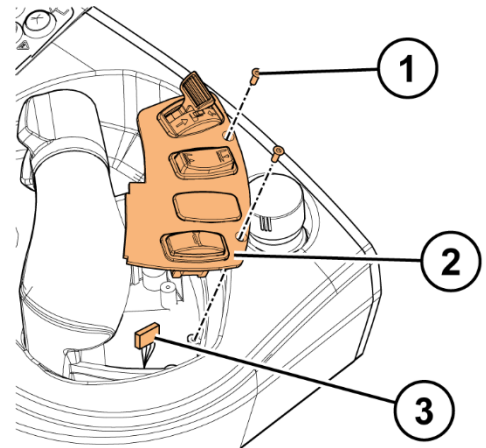

4. Remove the screw on top of the accelerator.
5. Remove the accelerator knob.
6. Remove the accelerator.

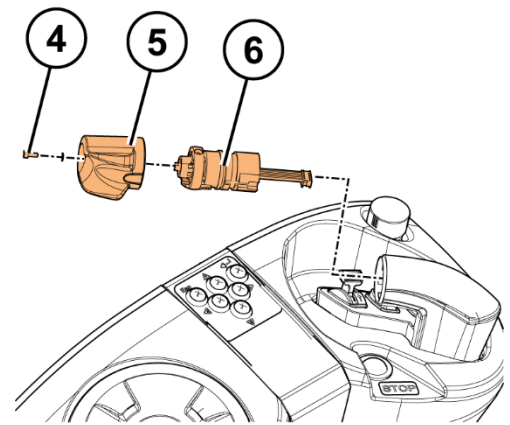

To install the accelerator, repeat the steps in the reverse order.

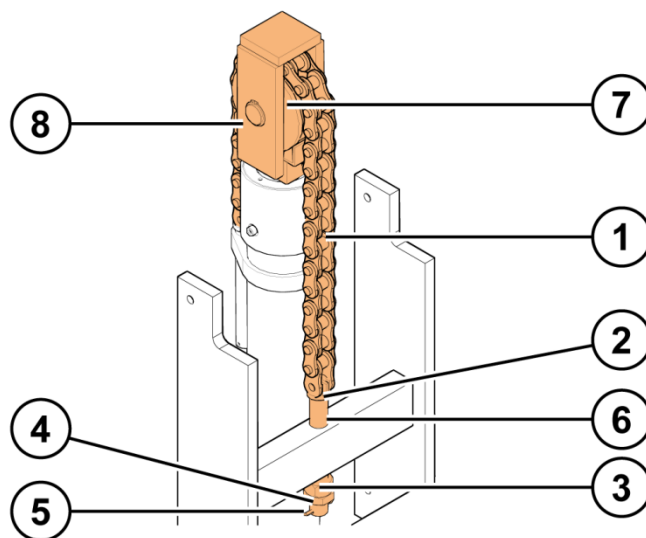

Figure 61. Mast chains overview

- | | |
|-------------------|------------------|
| 1. Chain | 5. Locking pin |
| 2. Chain anchor | 6. Mounting hole |
| 3. Tightening nut | 7. Chain wheel |
| 4. Locking nut | 8. Chain yoke |

5.14.7.1 Inspect the mast chains

Examine and lubricate the chain masts after each 300 hours of operation (or more frequently in severe or extreme environments). Do these checks for the chains:

Elongation

To measure the elongation of the chains, you need a slide gauge and a chain gauge.

Measure the mast chain from the section that moves over the chain wheel as that part of the chain flexes the most. In case the chain is long, measure it at two different points.

8. Install the bottom chain anchor to the mounting hole.
9. Install but do not tighten the 2 nuts to the chain anchor.
10. Install the locking pin to the chain anchor.

11. Adjust the chain tension. See section 5.14.7.3.

5.14.8 Lifting cylinder

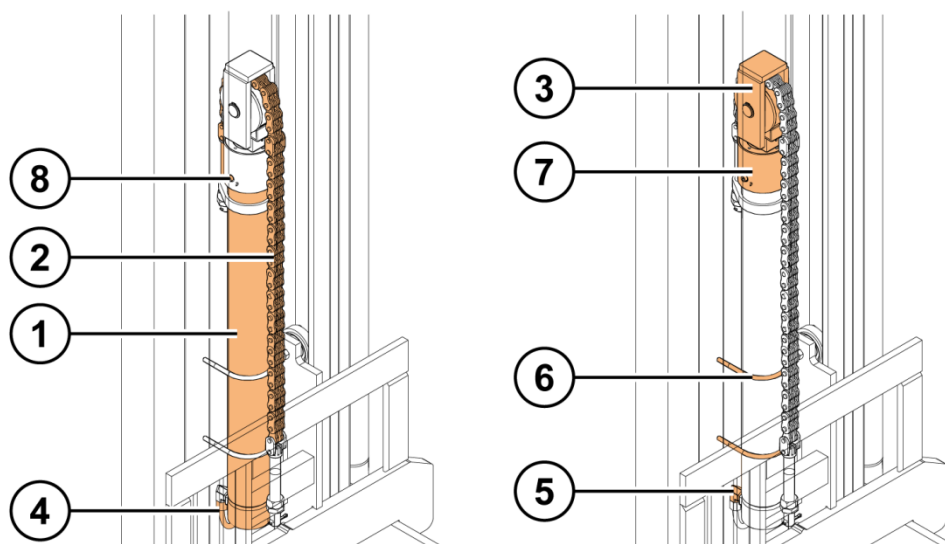
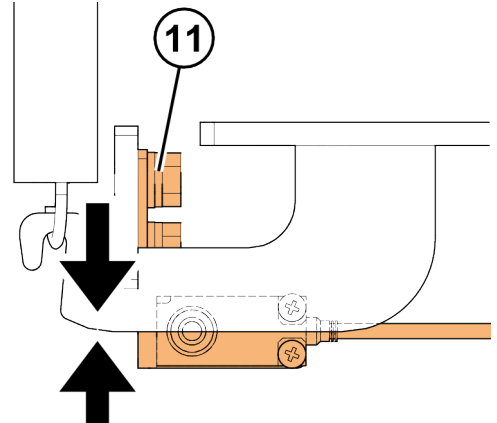

Figure 71. Lifting cylinder overview

1. Lifting cylinder
2. Chain
3. Chain yoke
4. Hydraulic pipe/hose

5. Hydraulic connector
6. Lifting cylinder collar
7. Sealing housing
8. Bleed screw

11. Adjust the operator presence sensor.
NOTE: Make sure that the sensor senses the counterpart in the middle of the movement range.



12. Install the back cover, see section 5.4.4.
13. Install the machinery cover, see section 5.4.3.

5.15.1.3 Replace the rubber stoppers

To replace the rubber stoppers:

1. Remove the spring, see section 5.15.1.1.

2. Remove the floor plate.

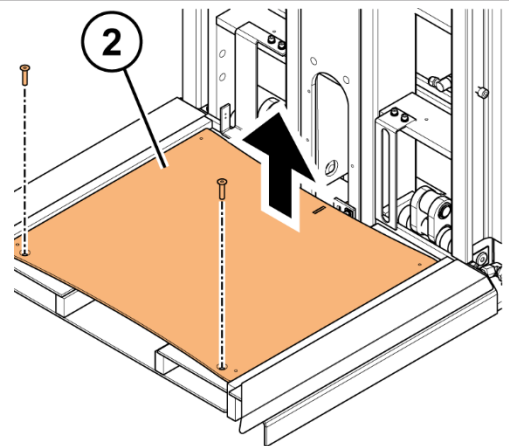

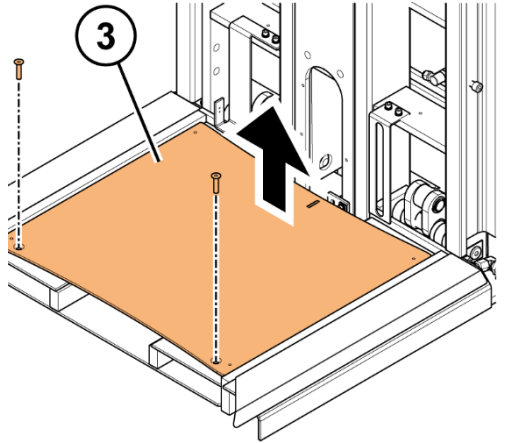
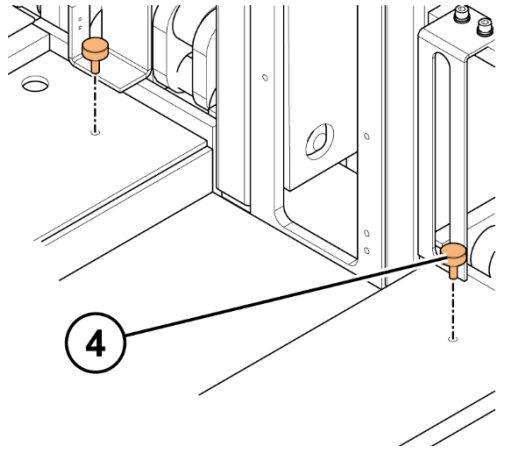
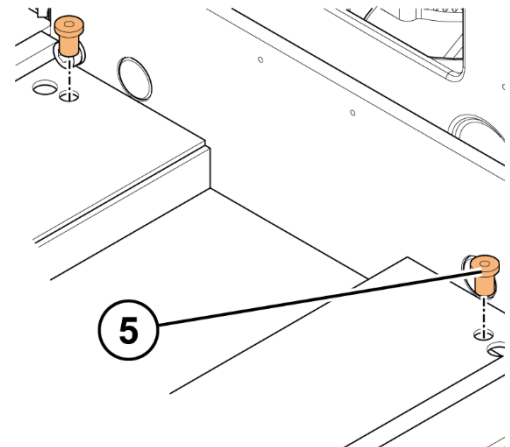
<p>3. Remove the 2 screws of the floor plate.</p>	
<p>4. Examine the rubber stoppers on the rear part of the truck frame floor. Replace the rubber stoppers, if necessary.</p>	
<p>5. Examine the rubber stoppers on the front part of the truck frame floor. Replace the rubber stoppers, if necessary.</p>	
<p>6. Install the floor plate. NOTE: Tighten the screws of the floor plate by hand.</p> <p>7. Install the spring, see section 5.16.2.</p>	

7. Remove the support between the scissors. Be careful when you remove the support. The scissors can move and cause an injury.

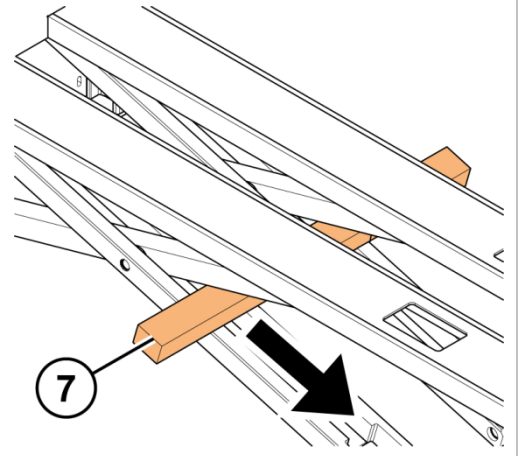

5.17.3 Disassemble the scissors

1. Disassemble the scissor lift fork, see section 5.17.4.
2. Remove the circlips.
3. Remove the shafts that hold the scissors together.
4. Remove the bearing.
5. Move the scissors apart.

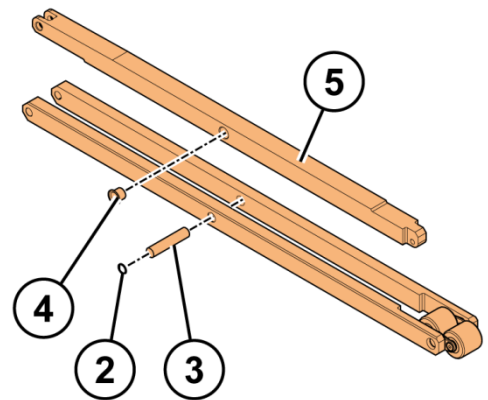

IDENTIFIER	DESCRIPTION
M#	Motor
V#	Diode
A#	Controllers and displays
K#	Contactors and relays
X#	Connector. Contact numbers are marked on individual wires.
XX#	Splice. Multiple wires are connected together at this point.

Figure 79 shows the reference to which Figure 78 referred.

15	16
----	----

A
(O

J14
1/13

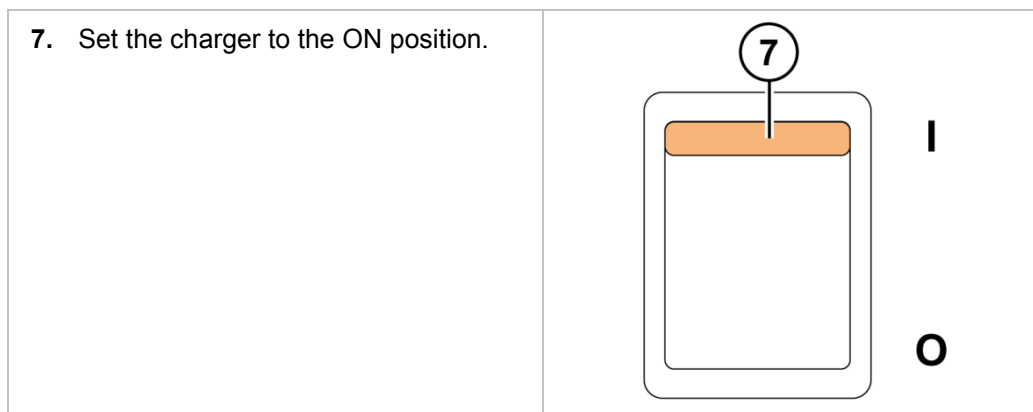

Figure 79. Page 8, zone 16, wiring reference J14

Note the numbers below the wiring reference J14. These numbers (1/13) direct you back to the page (and zone) shown in Figure 78.

INPUTS & OUTPUTS	4 / 9	REV H
	3-7109	

Figure 80. Page numbers (4/9), circuit diagram number (3-7109) and revision letter (H)



When the battery is charged:

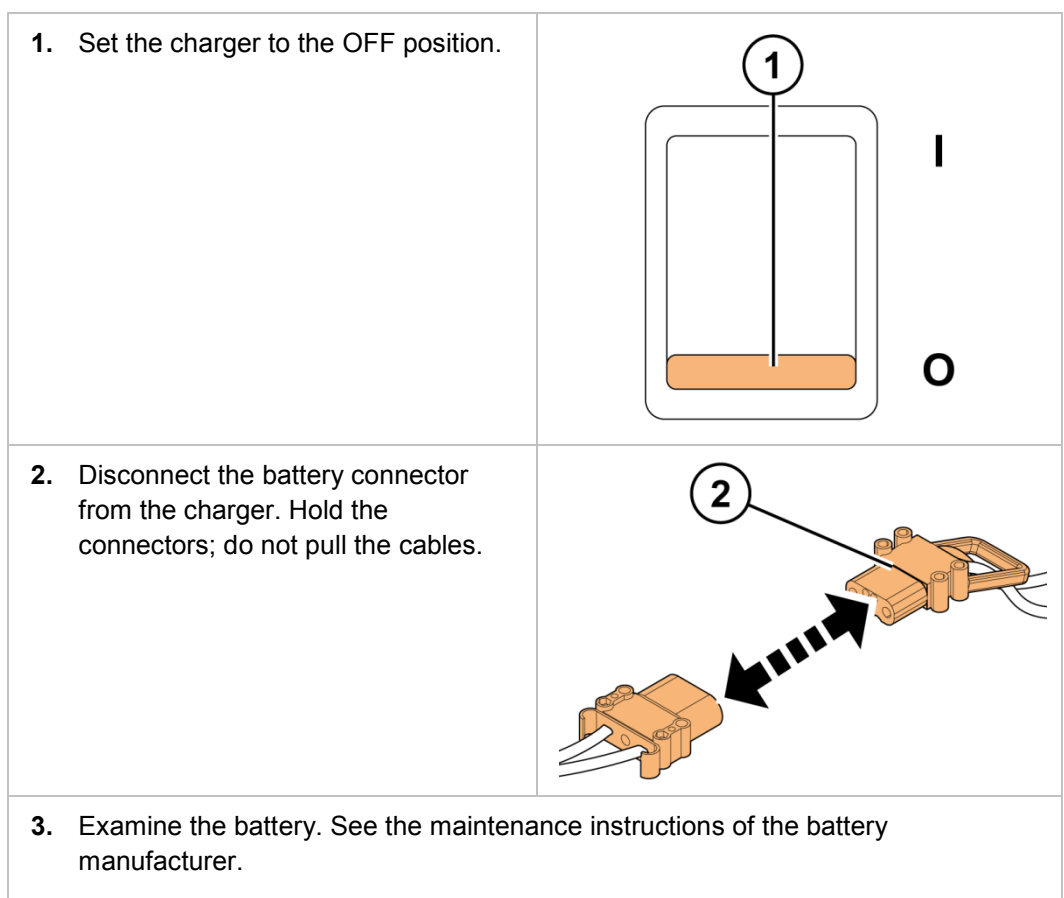

8.2.2 Traction controller

This truck has the COMBI AC-1 controller, which performs all the electric functions that are usually present in walkie and rider pallet trucks, stackers and low level order pickers.

The controller has these functions:

- Controller for AC 700 W to 3.5 kW AC motors
- Pump controller for series wound DC motors up to 7.5 kW
- Drivers for ON/OFF electrovalves and for one proportional valve
- CAN bus interface
- Interface for serial tiller head, CAN bus tiller or serial tiller
- Flash memory
- Double microcontroller.

8.2.3 Traction controller connector

CAUTION



Before any inspection or repair work, turn the key switch to the OFF position, disconnect the battery connector, discharge all controllers and record the places of the harness connections before disassembly.



When you disconnect the connector, hold the connector housing and plug and unlock the connector. If you hold the case you can cause damage to the inside card. If you hold the cable you can break the wire.



If the high-power cable terminals of the battery-operated vehicle are not tightened correctly, the increased contact resistance causes excessive heat generation, and can even cause a fire. To prevent accidents and equipment problems, examine the torque of the high-power cable terminals regularly. Do not pull the cables to examine connections or during adjustment. If the cable terminal sections are moved, tighten the connections again.

6. Remove the screws that attach the controller fan to the electric panel.
7. Disconnect the controller fan connector.
8. Remove the controller fan.

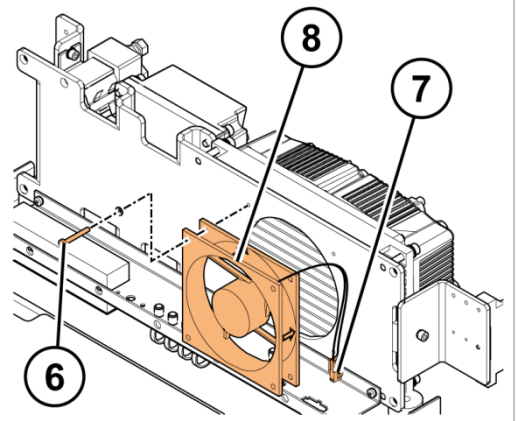

8.3 Truck connector

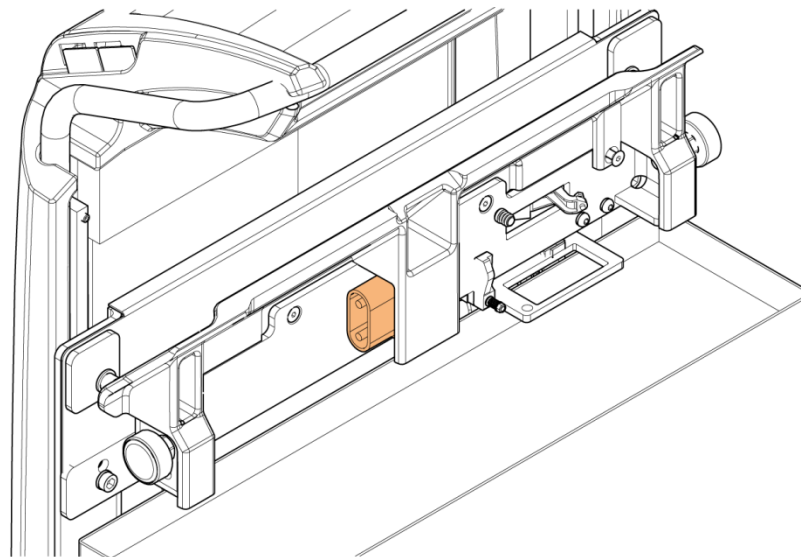

Figure 93. Truck connector overview

8.4.3.4 Steering motor

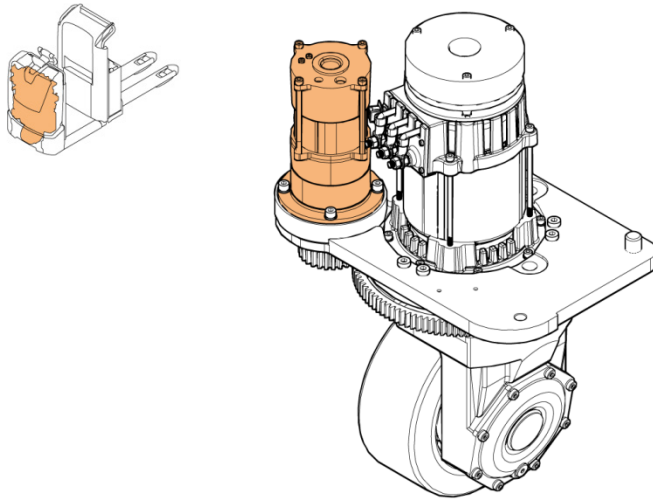

Figure 98. Steering motor overview

Type	3-phase AC
Voltage	15 V
Output power	0.3 kW

8.5.4 Steering wheel sensor



NOTE: The steering wheel sensor is in the control panel of the 360° steering.

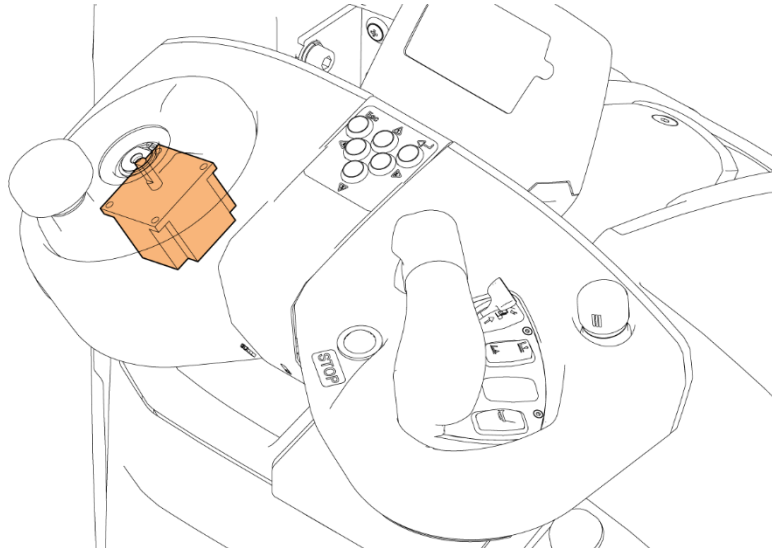

Figure 107. Steering wheel sensor overview

Functionality check of the steering wheel sensor:

1. Measure the coil resistance: measure on the resistance area between the connector X22A/ 1–2 pins and X22B/ 1-2 pins.
The value must be $\sim 29 \Omega$.
2. Measure the ground leakage: measure on the resistance area between the X22A/1 (or X22B/1) and steering wheel frame.
The value must be $\sim \infty \Omega$.
3. If the values do not agree with the above, replace the steering wheel sensor.

8.5.10.2 Lifting platform slow operating speed sensor

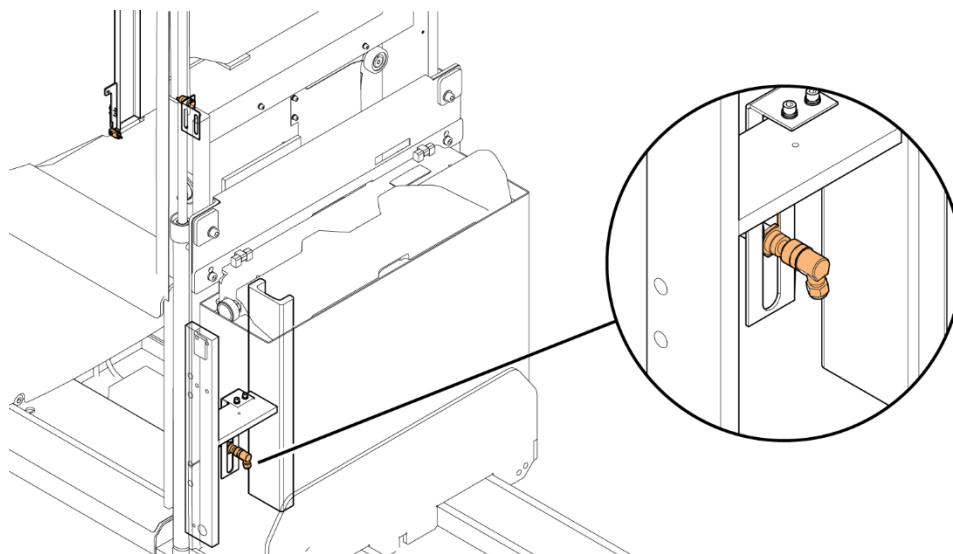

Figure 115. Lifting platform slow operating speed sensor

Type	Inductive proximity sensor
Size	M18 × 1 cylindrical, length 67 mm
V _s	10 - 65 Vdc
Switching output	PNP, NO
Electrical wiring	M12 connector / DC 3-wire, V _s = BRN, GND = BLU, signal output = BLK
Sensing range	5 mm

Functionality check of the lifting platform slow operating speed sensor:

1. Connect the supply voltage between the brown (+) and blue (-) wires. Measure the supply voltage between the wires.
The value must be i.e. +24 Vdc.
2. Measure between the blue (-) and black (output) wires on the voltage area.
When a supply is connected and there are no metallic objects within the sensing range, the value is approximately 0 V.
When a metallic object is moved in the sensing range, the value is the same as the supply voltage, i.e. +24 Vdc.
3. If the values do not agree with the above, replace the sensor.

10 Hydraulic operation

This chapter presents the hydraulic operation of the truck.

⚠ CAUTION



Make sure that you have the correct version of the hydraulic schematic diagram for the truck model you do maintenance to. Speak to your supplier or technical support for information on getting up to date documentation for your truck model.

The hydraulic schematic diagram shown in Figure 123 illustrates the operation of the hydraulic system.

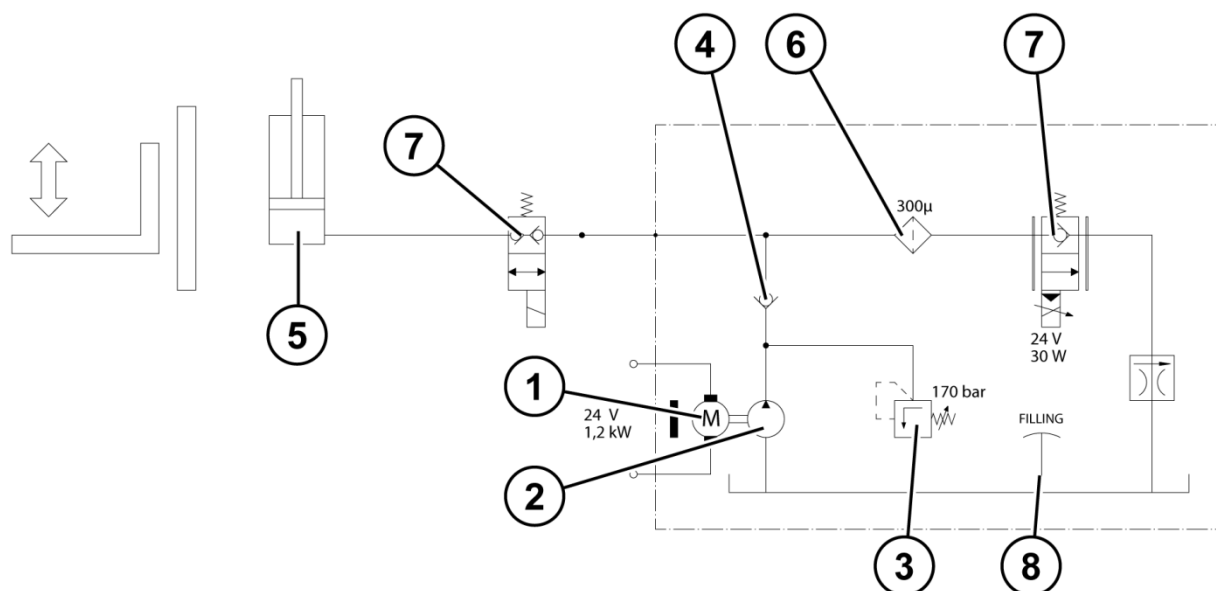

Figure 123. Hydraulic system overview for models with the fixed platform

- | | |
|------------------------|------------------------------------|
| 1. Pump motor | 5. Lifting cylinder |
| 2. Hydraulic gear pump | 6. 300 μ sieve |
| 3. Relief valve | 7. Solenoid valve |
| 4. Check valve | 8. Hydraulic oil tank filling hole |

10.6 Hydraulic system with the lifting platform

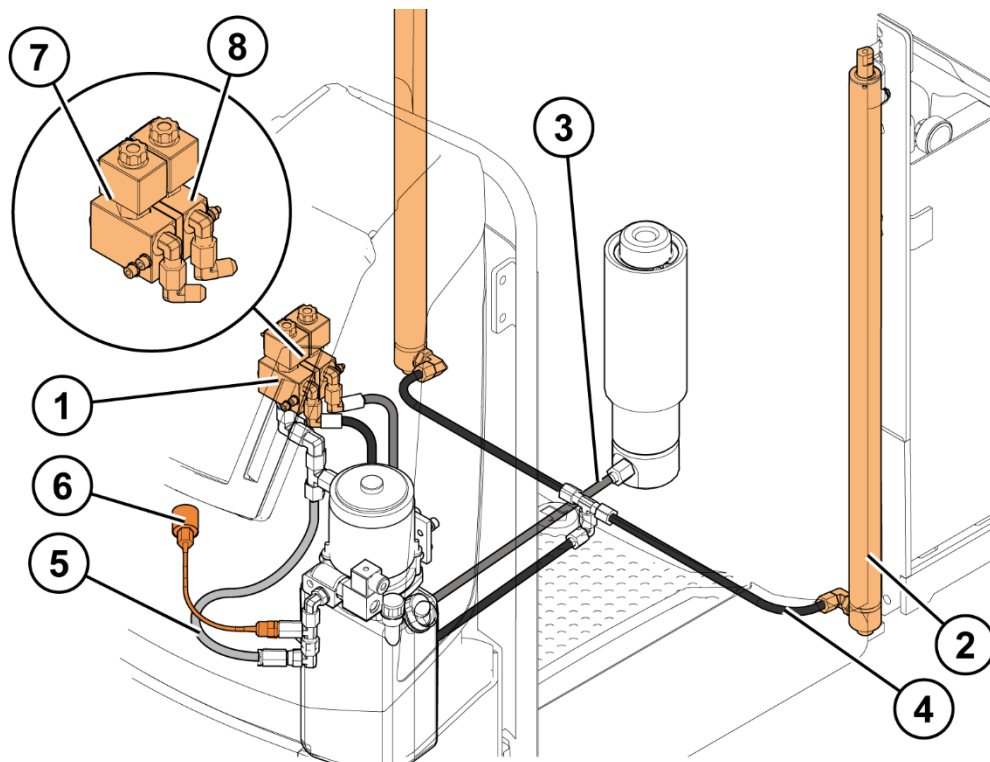

Figure 130. Hydraulic system with the lifting platform overview

- | | |
|--|---|
| 1. Valve unit | 5. Hose from the aggregate to the 2 additional valves |
| 2. Hydraulic cylinder | 6. Pressure sensor hose |
| 3. Load handling hose: forks, scissor lift or simplex mast | 7. Lifting platform (XY2) valve |
| 4. Lifting platform pipe | 8. Load handling device (XY3) valve |

The solenoid valve is an electrically controlled hydraulic valve that has 2 main parts: a solenoid (coil) and a valve. The solenoid converts electrical energy into mechanical energy which, in turn, opens or closes the valve mechanically. This basic ON/OFF function is used to control the oil flow to the cylinders.

Type	Solenoid
Contact rating	24 Vdc / 20 W
Electrical wiring	Quick connect terminals 6.3 x 0.8 mm

PARAMETER	DESCRIPTION
Acceleration ramp end smoothing with load LOAD STOP SMOOTH	This parameter controls the smoothness when the direction change ramp is stopped with the maximum load. Default value: 3 Value range: <ul style="list-style-type: none"> • 0 Hz = Minimum • 100 Hz = Maximum
Maximum load weight MAX LOAD WEIGHT	This parameter controls the maximum load of the truck. Default value: 2000. NOTE: This parameter is used only if the truck has the pressure sensor. Value range: <ul style="list-style-type: none"> • 0-3,000

Table 15. Submenu: adjustments

PARAMETER	DESCRIPTION
Adjust battery nominal voltage SET BATTERY TYPE	This parameter sets the nominal battery voltage, which is 24 V. Factory setting.
Adjust battery voltage ADJUST BATTERY	Factory setting.
Pressure sensor low ADJ MIN LOAD	The load sensor minimum load teaching.
Pressure sensor high ADJ MAX LOAD	The load sensor maximum load teaching.
Throttle FW min SET ACCELER. MIN	360° accelerator minimum teaching, ~ 1.0 V. Default value: 1.
Throttle FW max SET ACCELER. MAX	360° accelerator maximum teaching ~ 1.7 V. Default value: 1.7.
Throttle BW min SET ACC MIN REV	360° accelerator minimum teaching rearward ~ 0.8 V. Default value: 0.8.
Throttle BW max SET ACC MAX REV	360° accelerator maximum teaching rearward ~ 0.1 V. Default value 0.1.
Lift min AUX FUNCTION 4	360° hydraulic minilever minimum teaching ~ 1.0 V. Default value: 1.
Lift max AUX FUNCTION 5	360° hydraulic minilever maximum teaching ~ 1.7 V. Default value: 1.7.

PARAMETER	DESCRIPTION
Programmable output 2 MULTIPUR. OUT #2	Value range: <ul style="list-style-type: none"> • 0 = Disabled • 1 = Drive forward active • 2 = Drive backward active • 3 = Drive forward or backward active • 4 = Lift active • 5 = Lower active • 6 = Lift or lower active • 7 = Forward or backward or lift or lower active • 8 = Multipurpose input 1 active / fixed hydraulic speed • 9 = Drive forward or backward active and right blink control (default)

Table 21. Special adjustments

PARAMETER	DESCRIPTION
Proportional valve ditter amplitude DITTER AMPLITUDE	Proportional valve adjustment. Value range: <ul style="list-style-type: none"> • 0-7
Proportional valve ditter frequency DITTER FREQUENCY	Proportional valve adjustment Value range: <ul style="list-style-type: none"> • 0-83.3

12.3 Steering controller

Table 22. Main menu: parameter change

PARAMETER	DESCRIPTION
Steering wheel related speed SPEED LIMIT	Traction wheel speed related to steering wheel rotation speed. 9 = Traction wheel turns with constant speed compared to steering wheel. Value range: <ul style="list-style-type: none"> • 0-9
Steering motor rotation speed when turning fast AUX FUNCTION #3	Factor between steering wheel and wheel. Increasing value increases motor rotation speed, but only when steering wheel is turned quickly.
Steering gear ratio SENSITIVITY	Steering sensitivity. Default value: 5. Value range: <ul style="list-style-type: none"> • 0 = Minimum • 9 = Maximum

CODE	ALARM / CONSOLE DESCRIPTION		
66	Battery charge lower than 10% BATTERY LOW	(Warning)	Stored
	<p>This warning occurs when the battery charge is less or equal to 10% of a full charge and the BATTERY CHECK parameter is set to a value other than 0. The BATTERY CHECK parameter is in the SET OPTION menu.</p> <p>When this alarm occurs:</p> <ul style="list-style-type: none"> • Charge the battery. • If the alarm occurs after the battery is fully charged, measure the battery voltage with a voltmeter. Compare the measured value with the value of the BATTERY VOLTAGE parameter. If values are different, adjust the value of the ADJUST BATTERY parameter. <p>When you adjust the battery voltage, measure the voltage from the key line, after the reverse polarity protection diode. A good measuring point is, for example, the emergency stop button terminal. If you measure the battery voltage anywhere else, it will cause invalid operation of the battery discharge indicator.</p>		
74	Contactor driver circuit error DRIVER SHORTED	(Alarm)	Stored
	<p>This alarm occurs if the driver of the main contactor coil is shorted or the coil is disconnected.</p> <p>When this alarm occurs, do these checks:</p> <ul style="list-style-type: none"> • If there is a short circuit between the connector XA1 pin 12 and –Batt. • Condition of the wiring of the main contactor related harness. <p>If there is no short circuit and the wiring is not damaged, the driver circuit in the traction controller is broken.</p>		
75	Contactor driver damaged CONTACTOR DRIVER	(Alarm)	Stored
	<p>This alarm occurs when the main contactor driver is not able to drive the load. The device itself or its driver circuit is damaged. This alarm is not related to external components. When it occurs, replace the traction controller.</p>		
76	Contactor coil shorted COIL SHORTED	(Alarm)	Stored
	<p>When this alarm occurs, there is a short circuit on one of the coils connected to the outputs of the traction controller. When the overload condition is removed, the alarm exits automatically: a travel demand is released and enabled.</p> <p>When this alarm occurs, do these checks:</p> <ul style="list-style-type: none"> • The connections between the controller outputs and loads. • If there are no external problems, the controller is broken, and you must replace it. 		
78	Accelerator voltage not OK VACC NOT OK	(Alarm)	Stored
	<p>This alarm occurs when the difference between the accelerator output voltage and the acquired minimum during PROGRAM VACC is more than 1 V.</p> <p>When this alarm occurs, examine the functionality of the accelerator. Do the accelerator calibration wizard function.</p>		

CODE	ALARM / CONSOLE DESCRIPTION		
238	Lift and lower demands active simultaneously LIFT + LOWER	(Warning)	
	This alarm occurs when the lifting and lowering demands are active at the same time. Use a tester to find the possible causes for this alarm. If both demands are active at the same time, examine the switches and wiring. If no lifting and lowering signals are active at the same time outside the controller, the problem is in the pump controller and you must replace it.		
239	Incorrect pump starting sequence PUMP INC START	(Warning)	
	This alarm occurs when the pump start sequence is incorrect. Possible reasons for this alarm are: <ul style="list-style-type: none"> The pump request is active at start-up. The pump request is active, but the steering wheel is not in the operating position. The alarm can also be caused by an error sequence made by the truck operator. When this alarm occurs: <ul style="list-style-type: none"> Make sure that the wirings are not damaged. Make sure that the microswitches are not damaged. If the wiring and microswitches are OK and the alarm was not caused by an error made by the truck operator, replace the pump controller.		
240	Error in pump command value range PUMP VACC NOT OK	(Warning)	
	This alarm occurs when the lift lever voltage is out of range. When this alarm occurs, make sure that the connectors and cables are not damaged. If the connectors and cables are not damaged, replace the steering wheel.		
242	Pump chopper current sensor feedback is too low CURR. SENS LOW	(Alarm)	Stored
	This alarm occurs when the pump chopper feedback sensor feedback is too low (below 0.5 V). This alarm is not related to external components. When it occurs, replace the pump controller.		
243	Eeprom checksum failed EEP. CHECKSUM	(Alarm)	Stored
	This alarm occurs, when the EEPROM checksum failed. When this alarm occurs, clear the EEPROM. Set the power of the truck OFF and ON and read the result. If the alarm occurs permanently, replace the controller. If the alarm disappears, the default parameters are restored.		
244	RAM checksum failed RAM WARNING	(Alarm)	Stored
	This alarm occurs when the RAM checksum failed. This alarm is not related to external components. When it occurs, replace the pump controller.		

14 Service data

14.1 Special tightening torques

Traction wheel	80 Nm
Traction controller terminal bolts	13-14 Nm
Steering controller terminal bolts	2.5-3 Nm

14.2 Tightening torques for standard bolts and nuts

Bolt size	Pitch [mm]	8.8		10.9		12.9	
		Nm	kg-m	Nm	kg-m	Nm	kg-m
M4	0.70	2.8	0.3	4.1	0.4	4.8	0.5
M5	0.80	5.5	0.6	8.1	0.8	9.5	1.0
M6	1.00	9.5	1.0	14	1.4	16.5	1.7
M7	1.00	15	1.5	23	2.3	28	2.9
M8	1.25	23	2.3	34	3.5	40	4.1
	1.00	24	2.4	36	3.7	43	4.4
M10	1.50	46	4.7	68	6.9	79	8.1
	1.00	52	5.3	76	7.7	89	9.1
	1.25	49	5.0	72	7.3	84	8.6
M12	1.75	79	8.1	115	11.7	135	13.8
	1.25	87	8.9	125	12.7	150	15.3
	1.50	83	8.5	120	12.2	145	14.8
M14	1.75	125	12.7	185	18.9	215	21.9
	1.50	135	13.8	200	20.4	235	24.0
M16	2.00	195	19.9	280	28.6	330	33.7
	1.50	205	20.9	300	30.6	360	36.7

15.1 Accessory rack

The accessory rack is different in truck models without the lifting platform and in truck models with the lifting platform, see Figure 137 and Figure 138 below.

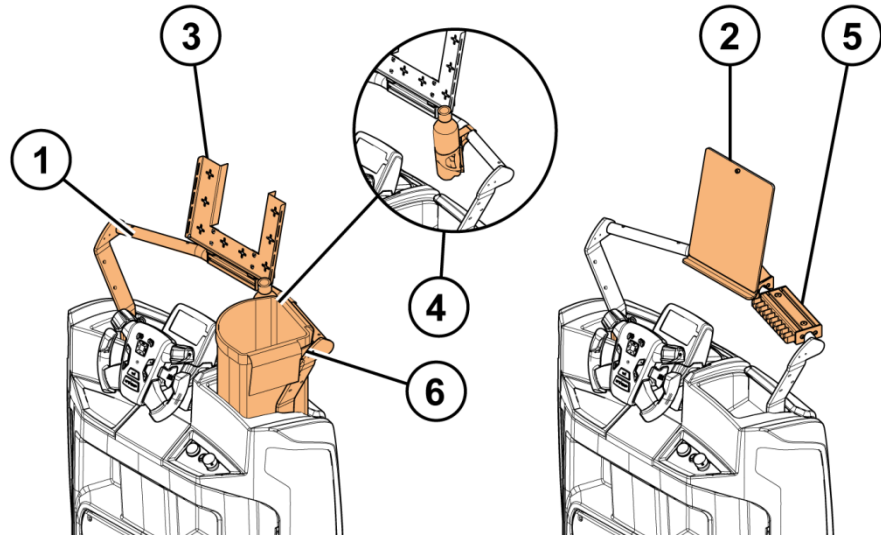

Figure 137. Accessory rack for a truck without the lifting platform overview

- | | |
|-------------------|----------------|
| 1. Accessory rack | 4. Bottle rack |
| 2. List bracket | 5. Pen rack |
| 3. Computer rack | 6. Garbage bin |

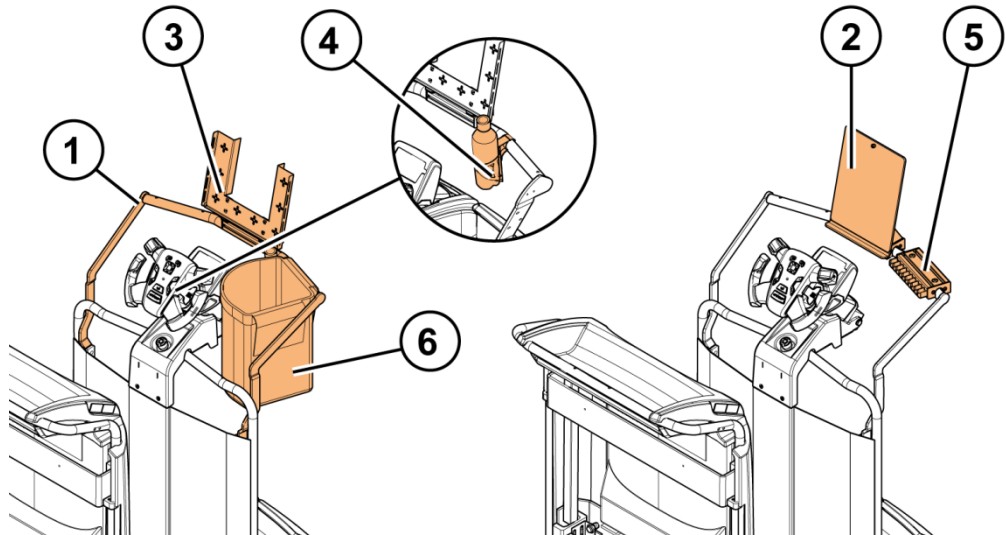

Figure 138. Accessory rack for a truck with the lifting platform overview

- | | |
|-------------------|----------------|
| 1. Accessory rack | 4. Bottle rack |
| 2. List bracket | 5. Pen rack |
| 3. Computer rack | 6. Garbage bin |

15.4 Picking plane



NOTE: The picking plane option can be installed to trucks with a lifting platform only.

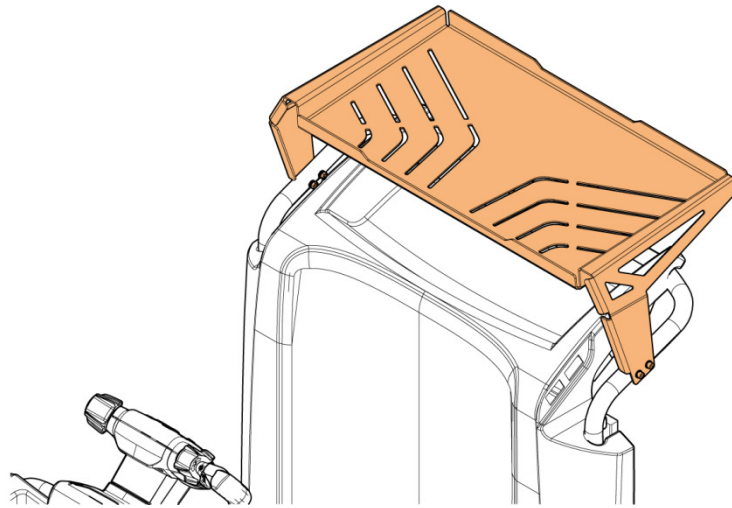
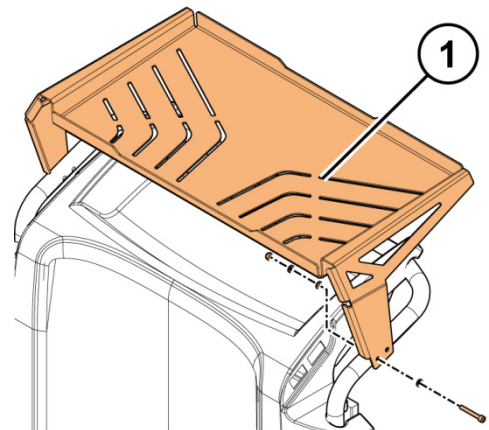

Figure 142. Picking plane overview

You can put orders on the picking plane when you pick orders on the second level.

15.4.1 Install the picking plane

1. Install the picking plane to the back support with screws.



CLICK HERE TO **DOWNLOAD** THE COMPLETE MANUAL

- Thank you very much for reading the preview of the manual.
- You can download the complete manual from: www.heydownloads.com by clicking the link below



- Please note: If there is no response to CLICKING the link, please download this PDF first and then click on it.

CLICK HERE TO **DOWNLOAD** THE COMPLETE MANUAL

4. Connect the battery connector.
Make sure that the battery cables stay fully safe in the frame of the truck.

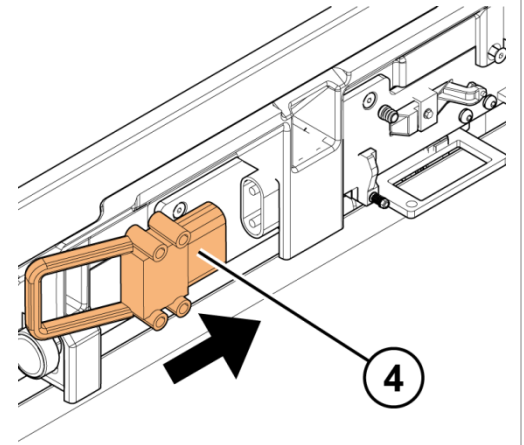

5. Close the battery locking mechanism.
6. Close the battery cover.
7. Set the power of the truck to ON.
8. Move the truck away from the battery changing area.

15.11 Hot storage modification



NOTE: The hot storage modification option is installed to the truck during manufacturing. Thus, this option must be selected before you buy the truck.

A standard truck can be continuously operated at a temperature of +5...+25°C and for short periods at a temperature of 0...+45°C. The recommended humidity is 30...95% (non-condensing). A truck that is specially made for hot conditions can be used in temperatures up to +45°C.

15.15.3 Install the SIM card



NOTE: You must write down and store the serial number of the Abbot2 main unit and the phone number of the SIM card.



The SIM card comes with the Abbot GPRS models. The SIM card is used for wireless data transfer.

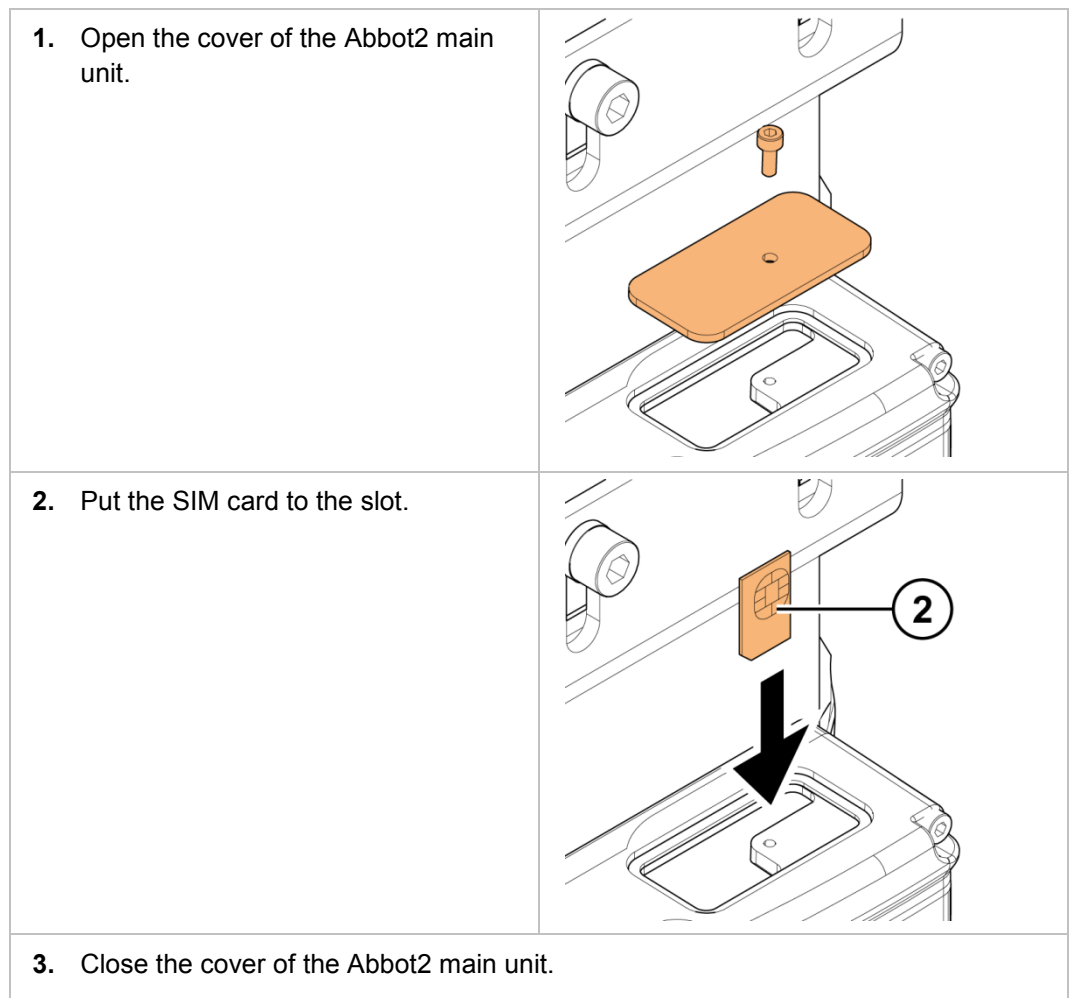

15.20.2 Intelligent Drive Assistant (IDA)

The Intelligent Drive Assistant (IDA) helps the truck operator with the operation of the truck. IDA comes with the functions below:

- Anti-locking brakes (ABS)
- Traction control in the traction wheel (TCS)

The anti-locking brakes (ABS) and traction control in the traction wheel (TCS) help the truck operator to operate the truck efficiently. See Figure 162.

With the ABS:

- The braking distance is shorter.
- The steerability of the truck when braking is better.
- Wear of the traction wheel decreases.
- It is easier to control the truck.

With the TCS:

- The truck operator can use a higher operating speed in curves.
- Slipping of the traction wheel decreases.
- Wear of the traction wheel decreases.
- It is easier to control the truck.

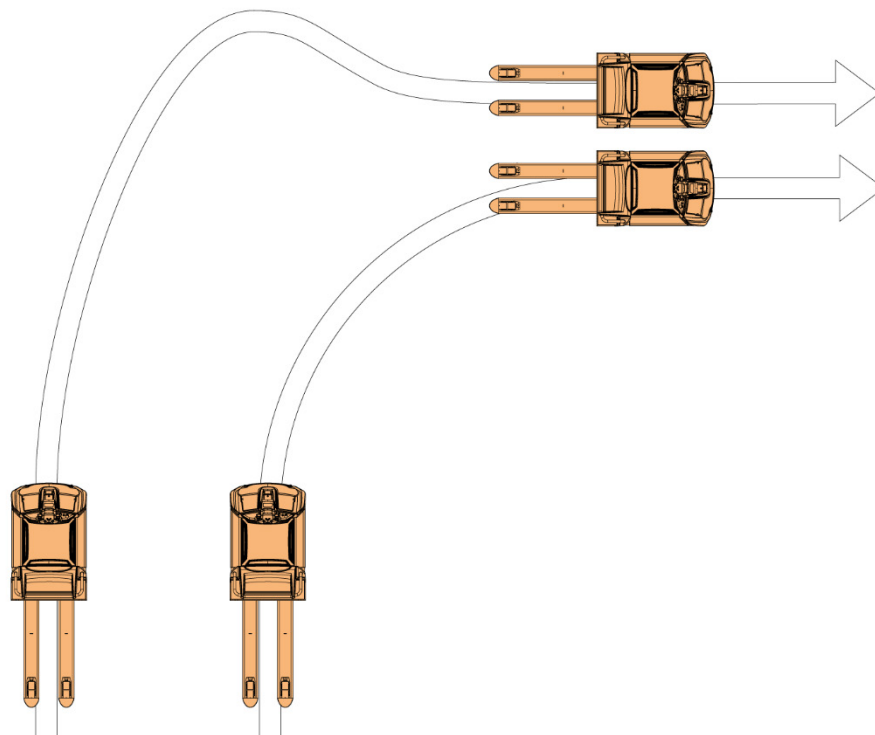

Figure 162. Truck operation with the Intelligent Drive Assistant

- Digital console
- Adjust the parameters with the digital console235
 - Connect the digital console to the truck233
 - Select the controller234
- Drive alarm
- Install the drive alarm317
- Drive unit
- Drive unit suspension72
 - Replace the shafts of the motor bed74
 - Replace the springs73
- E**
- Electric panel
- Contactors and relays178
 - Discharge the controllers.....170
 - Fuses179
 - Steering controller175
 - Traction controller171
- Electrical operation149
- Electrical steering
- Adjusting the electrical steering216
- Emergency stop button
- See *Control panel*
- Equipment pocket
- Install the equipment pocket.....300
- F**
- Folding seat
- Install the folding seat.....304
- Forks lift upper limit sensor
- SeeSensors
- Fuses
- Remove the controller fan180
- G**
- Guidance rollers
- Adjust the guidance rollers136
- H**
- HALL sensor
- SeeSensors
- High performance pack
- Intelligent Drive Assistant331
 - Load sensing cylinder328
- Horn
- Diode test with a multimeter214
- Hot conditions
- Hot storage modification311
- Hydraulic aggregate
- Disassemble the hydraulic aggregate.....227
 - Disassemble the oil tank228
- Hydraulic cylinder
- Replace the hydraulic cylinder229
- Hydraulic operation.....221
- Hydraulic symbols.....224
- Hydraulic system
- Hydraulic oil recommendations226
 - Maintenance points of the hydraulic system227
- Hydraulic system with the lifting platform231
- Hydraulic system with the simplex mast232
- I**
- Identification plates on the truck.....18
- Insulation resistance test217
- Insulation resistance of the battery220
 - Insulation resistance of the truck219
 - Insulation tester check218
 - Measure the insulation resistance218
 - Test voltage217

LOAD STOP SMOOTH	3	3	3	3	3	0-100Hz	Truck travel speed when direction change smoothness ramp is stopped with maximum load
MAX LOAD WEIGHT	2000	2000	2000	2000	2000	0-3000	Maximum load reached value for the load detection
AUXILIARY TIME	0.8	0.8	0.8	0.8	0.8	0-5s	Brake delay, for how long time truck is held in place with motor until brake is released
AUX FUNCTION 7	LEVEL 0	LEVEL 0	LEVEL 0	LEVEL 0	LEVEL 0		Factory Setting
AUX FUNCTION 13	20	20	8	8	20	0-100	How much traction braking control allows wheel to lock until it releases. Bigger value - more sensitive
AUX FUNCTION 12	1.5	1.5	9	9	0.3	0-100	How much traction acceleration control allows wheel to slip until it tries to reduce slipping. Smaller value - more sensitive
SET OPTIONS:							
TILLER SWITCH	HANDLE	HANDLE	HANDLE	HANDLE	HANDLE		Factory setting
HOUR COUNTER	RUNNING	RUNNING	RUNNING	RUNNING	RUNNING		Factory setting

RELEASE BRK PED.	3	3	3	3	3	0,1-5	Pedestrian release braking ramp. 0,1 = strongest
MAX SPEED FORW	100	100	100	100	100	10-100%	Maximum speed forward without load. 100% = fastest
MAX SPEED BACK	100	100	100	100	100	10-100%	Maximum speed backward without load. 100% = fastest
MAX SPD LOAD FWD	50	75	50	75	50	10-100%	Maximum speed forward with maximum load. 100% = fastest. Note! Do not exceed marked values for safety reasons
MAX SPD LOAD REV	50	75	50	75	50	10-100%	Maximum speed backward with maximum load. 100% = fastest. Note! Do not exceed marked values for safety reasons
MAX SPEED PED.	40	40	40	40	40	10-64Hz	Maximum pedestrian travel speed. 64 Hz = fastest
PED. STEER ANGLE	10	10	10	10	10	0-30°	Steering angle when pedestrian travel is allowed
FORKS CTB SPEED	50	50	50	50	50	10-100%	CNA-35: Speed reduction from lifting device. 100% = not in use
CUTBACK SPEED 1	21	21	21	21	21	10-100%	Speed reduction 1. 100% = disabled. Defines also 180° steering turtle mode speed.
SLOW SPEED CTB.	34	34	100	100	34	10-100%	CNA-18: Speed reduction when man lift is used 100% = not in use
HS CUTBACK	100	100	100	100	100	10-100%	Not used
CURVE CUTBACK	85	85	85	85	85	10-100%	Curve cutback speed. 100% = disabled
STEER DEAD ANGLE	1	1	1	1	1	0-9	How straight a head position steering must be to allow full travel speed. 0 = exactly. 0 = 2°, 1 = 10°, 2 = 20°, 3 = 30°, 4 = 40°, 5 = 50°, 6 = 60°, 7 = 70°, 8 = 80°, 9 = 90°
CURVE ACCELERATION	3.4	3.4	3.4	3.4	3.4	0,1-5	Curve acceleration when traction wheel is turned 90°
FREQUENCY CREEP	0.6	0.6	0.6	0.6	0.6	0-10Hz	Truck minimum travel speed
MAXIMUM CURRENT	75	75	75	75	75	10-100%	Inverter maximum current
ACC SMOOTH	1	1	1	1	1	0-9	Acceleration ramp smoothness. 0 = no smoothness

EN



Operation & Maintenance Manual

NO20NE
NO20NEP
NO10NEF
NO10NEFP
NO20NEX
NO20NEXP

MCFE
Hefbrugweg 77,
1332 AM Almere,
The Netherlands

WARNING! Do not overload!

Capacity plate for accessories. Detachable accessories affect the truck's lifting capacity. If the truck is used with detachable accessories, corresponding capacity plates must be attached to the truck.

Safety devices

- Emergency stop button
- Start button/key switch
- Operator presence sensing platform
- Parking brake button for emergency braking
- Audible signal horn
- Visible warning lights

See detailed descriptions below.

Operating devices

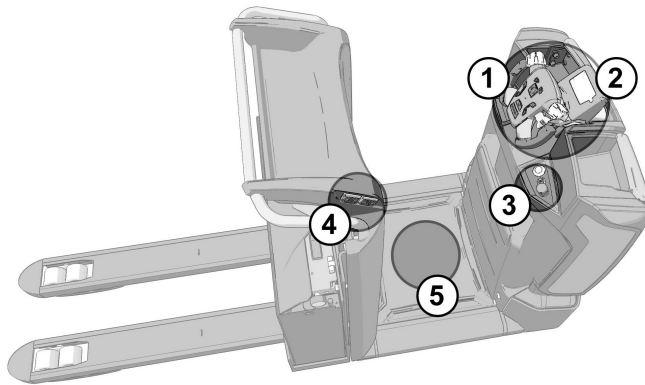

- Multifunctional steering wheel (1)
- Display (2)
- Emergency stop button and Start button or Key switch (3)
- Optional travel controls in the backrest (4)
- Operator's platform (5)

Operator's platform

Truck has an operator presence sensing platform.

To operate the truck, you must stand on the platform with your both feet.

Brakes

Operating brake. The truck has an operating brake for reducing the driving speed. Braking is carried out by the truck's speed control system. During braking the driving motor runs as a generator which output energy is restored into the battery.

To brake turn the accelerator to the opposite direction or release it to neutral.

- When you change the driving direction, the braking level is adjustable. Use the accelerator to set it suitable.
- When you release the accelerator, the braking level is not adjustable. Use the display's custom settings to set the release braking level suitable.

5. Driving instructions

Daily checks before operation

Carry out the daily maintenance check before using the truck. Neglecting daily maintenance may decrease the safety and reliability of the truck. Notify the site supervision immediately if you notice an error or deficiency during the check.

- Check the truck externally to see that there are no oil leaks.
- Check all wheels for damage or wear.
- Check the level of battery fluid in each battery cell. Top up with battery water if needed. The fluid surface should be about 15 mm above the plates. (Does not apply to maintenance-free batteries.)
- Check the gearbox for leaks. Also check the hydraulic pipes, hoses and connectors. No leaks or damage should be found.
- Switch on the power and test the operation of the hydraulic functions by raising and lowering the forks.
- Check the operation of the accelerator and steering by driving slowly forward and backward.
- Also check the operation of the other electrical functions.
- Check that the batteries are charged and locked in place.
- Check the operation of the horn.
- Accelerate the truck and check that the parking brake and emergency braking button function properly.
- Accelerate the truck and check that the emergency stop operates properly.
- Check the fastenings of the lifting chain (does not apply to pallet trucks).

Before you start

- Make sure that the daily maintenance has been carried out.
- Switch the power on and reset the emergency braking button check.
- Grip the steering wheel with your left or right hand or both hands. Use the accelerator and hydraulic controls either with your left or right hand.
- Take a position where your both feet are on the operator's platform.

Driving

- Press the accelerator lightly; the parking brake is automatically released and the truck starts moving.
- To brake, reverse the accelerator.
- Steer the truck smoothly because abrupt movements of the steering wheel may cause a dangerous situation, especially when driving at high speeds.
- Anticipate possibly dangerous situations so that you can avoid risks of accident or injury.

NOTE *Due to safety reasons, the truck may be adjusted to travel slower to the direction of the forks.*

Electronic steering system

The truck is equipped with a fully electronic steering system. The steering wheel movement is transmitted without a mechanical connection to the steering motor that controls the drive wheel.

NOTE *Turning of the drive wheel is not restricted in the 360° steering option. When starting off, make sure that the truck moves in the desired travelling direction.*

NOTE *Do not turn the steering wheel unnecessarily when the truck is not moving. It can cause the drive wheel to wear unevenly.*

Safety

The steering system performs a self-test every time the truck's power is turned on. The test lasts for less than a second, after which the truck is ready for operation.

If a fault is detected, the steering system's control unit stops the truck and engages the magnetic brake.

2. Apply the parking brake if the truck does not have an automatically acting parking brake.
3. Switch off the power from the truck.
4. Disconnect the recharging plug.
5. Adjust the height of the changing device so that the top of the rollers is at the same level as the rollers in the truck.

NOTE *If you are using a battery changing device that is not fixed to the floor, make sure that its brake is applied.*

6. Release the battery locking.
7. Stand beside of the changing device and pull the battery out onto the changing device (see picture below) or alternatively stand on the other side of the truck and push the battery out onto the changing device.

WARNING! *Do not place your foot between the rollers of changing device and pull the battery towards yourself! CRUSHING HAZARD!*

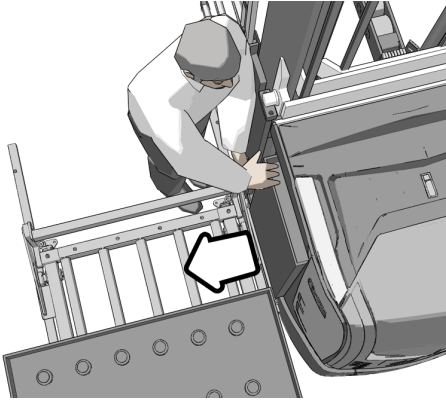

Installing a charged battery

1. Check the fluid level of the charged battery. Refill if necessary.

CAUTION! *Battery fluid is harmful. Wear eye-protection while performing maintenance to the batteries.*

2. Disconnect the battery from the charger.
3. Move the battery changing device sideways.
4. Insert the charged battery into the truck.

WARNING! *Do not place your fingers between the battery box and the truck chassis! CRUSHING HAZARD!*

5. Close the battery locking.
6. Connect the recharging plug.
7. Switch on the power to the truck.
8. Drive the truck away from the battery changing place.

Symptom	Fault	Action
		Contact maintenance personnel.
	Short voltage break (less than 5 seconds).	Switch off the power and wait at least 5 seconds, then switch the power back on.
	Steering controller is faulty.	Contact maintenance personnel.

CHANGE: FORKS CUTBACK SPEED SENSOR

REV B

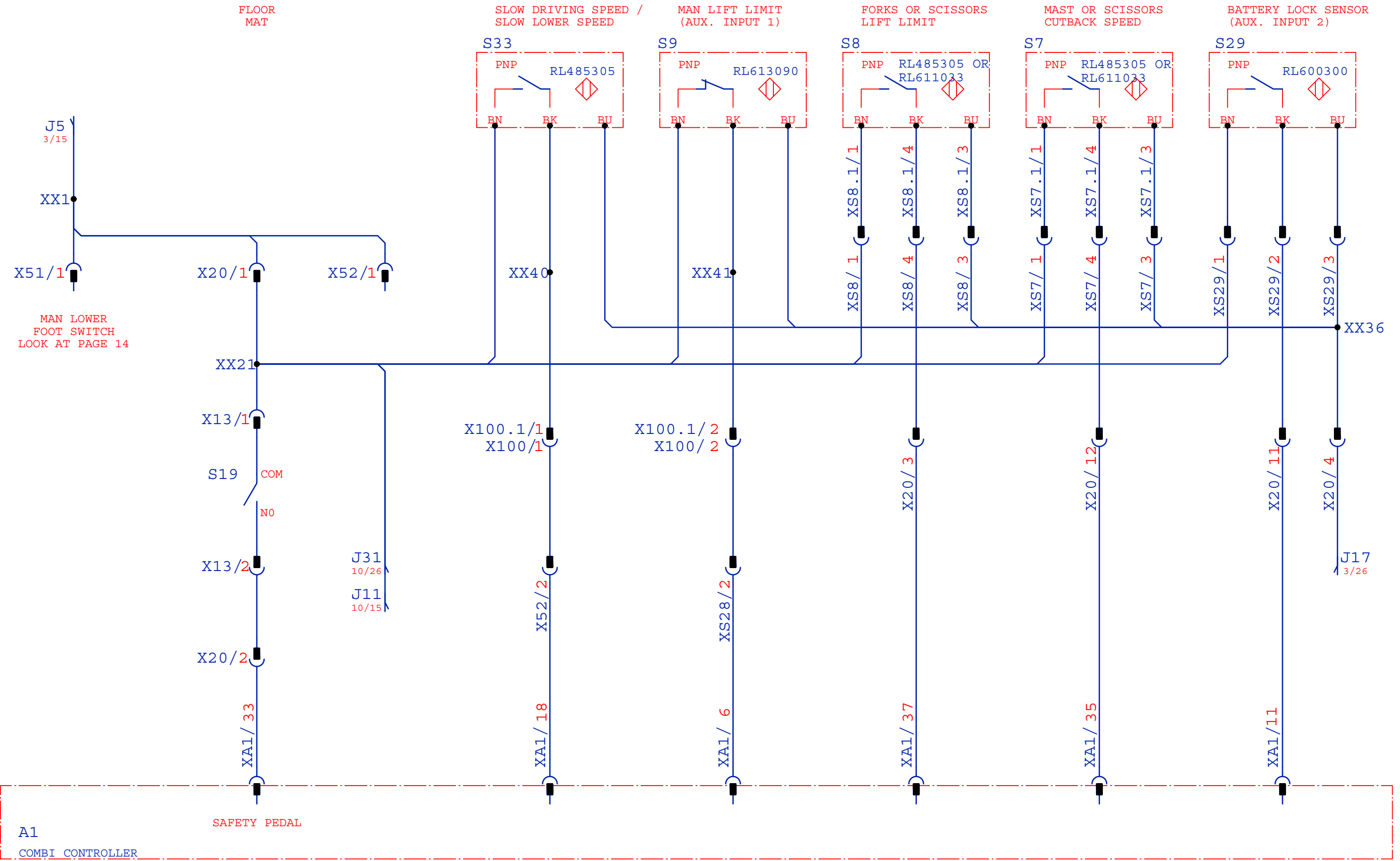

DATE:	
2011-04-15	

CIRCUIT DIAGRAM

TS1320000

NO20NEP, NO20NEX (P), NO10NEF (P)
DRIVE CIRCUIT 2

4 / 13	REV B
3-7117	

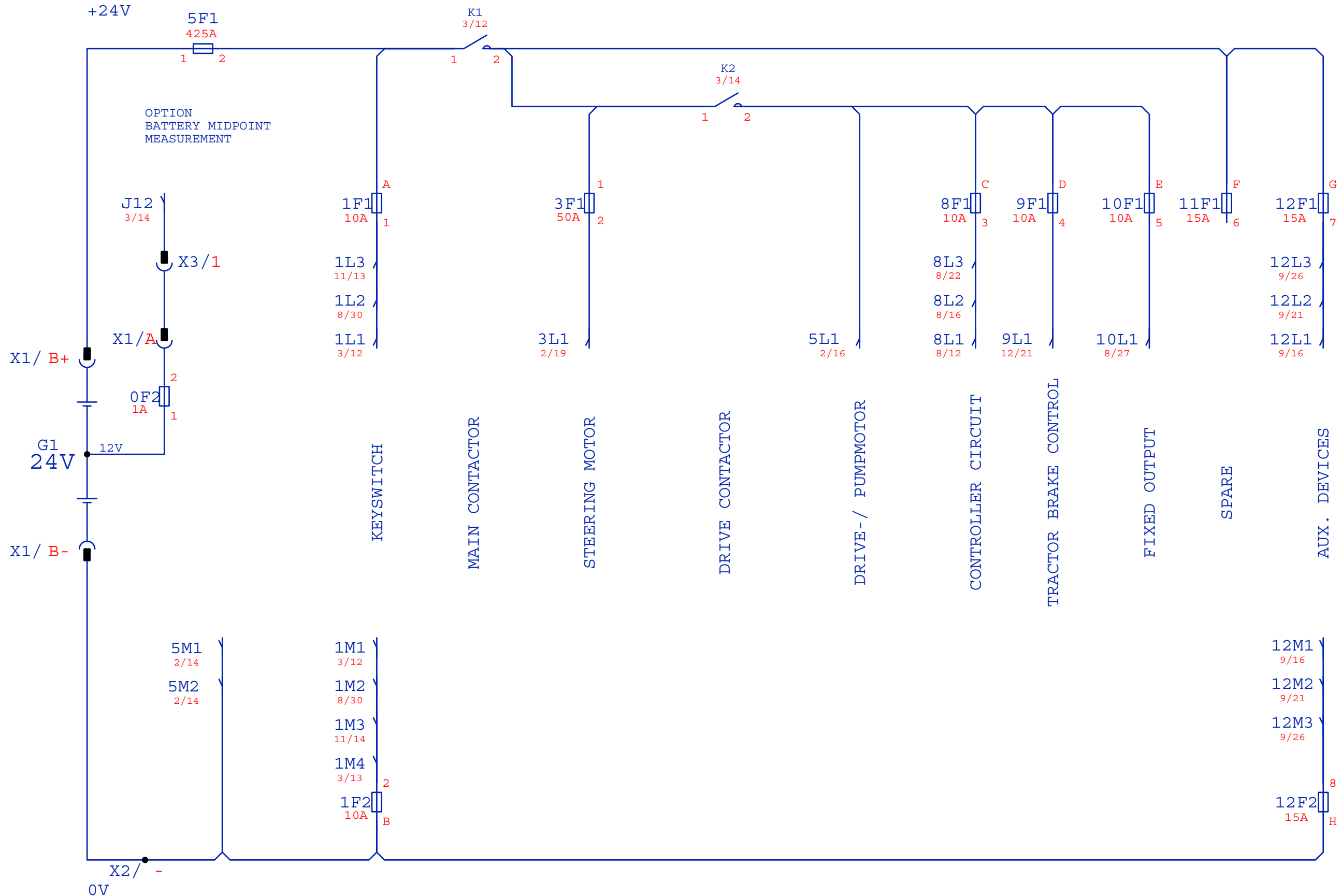

DATE :
2008-04-04

CIRCUIT DIAGRAM

TS1320212

NO20NE, NTR30N

POWER SUPPLY 24 V

1 / 12 REV I

3-7022

ABBOT 2

GROUNDING

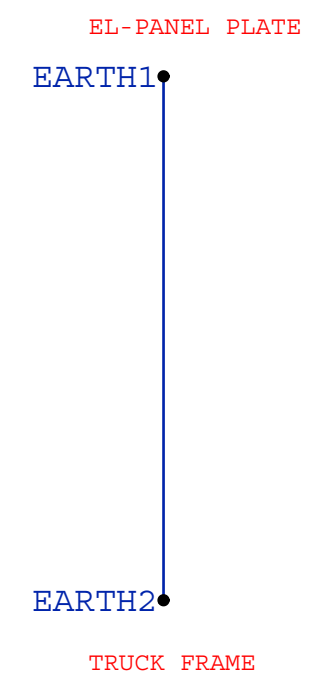
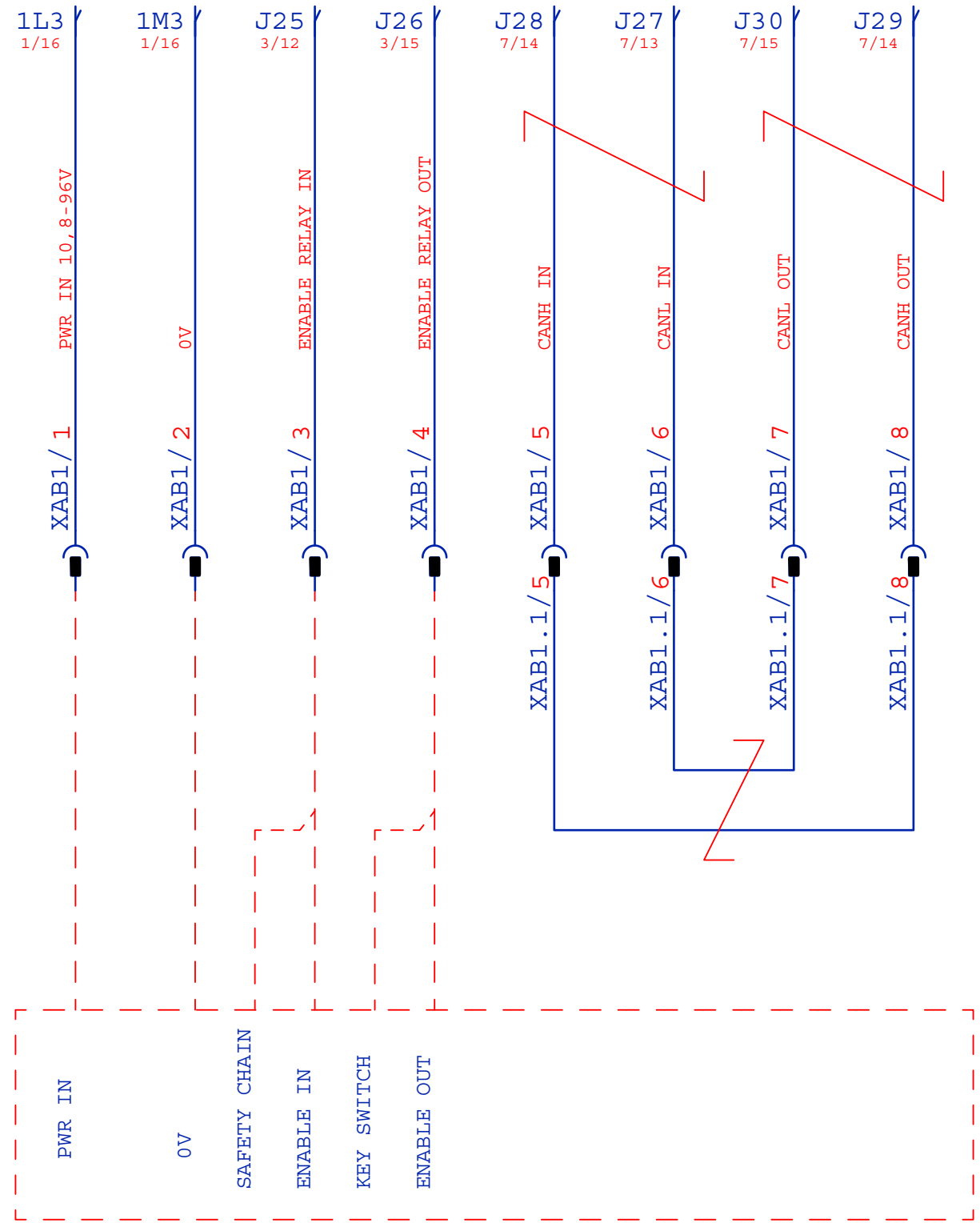

DATE:	
2008-04-11	

CIRCUIT DIAGRAM

TS1320212

NO20NE, NTR30N

ABBOT 2

11 / 12 REV I

3-7022

Also in AmpSeal version a third analog input is available in CNA#17 (a digital input is lost).

These other two analog inputs are checked by both microcontrollers too.

3.4 Analog motor thermal sensor input

Input CNA#12 in the AmpSaab version [CNA#22 in AmpSeal connector] is an analog input to receive an analog thermal sensor signal to measure the Traction Motor Winding Temperature. The analog device installed in the motor has to be specified, in order to insert the correct look-up table in the software. A digital device can also be used.

3.5 Speed feedback

The motor control is based upon the motor speed feedback (sensored software). The speed transducer is an incremental encoder, with two phases shifted at 90°. The encoder can be of different types :

- power supply: +12V

- electric output: open collector (NPN or PNP), push-pull.

COMBI AC1 could also be used without encoder, sensorless control.

This solution has to be discussed with Zapi technicians.



Note: The encoder resolution and the motor poles pair (the controller can handle), is specified in the home page display of the handset showing following headline:

CA1S2AE ZP1.07

That means:

CA1S= COMBIAC1 traction controller

2 = motor's poles pair number

A = 32 pulses/rev encoder

E = identifier for an extended memory hardware release inside

The encoder resolution is given by the second-last letter in the following list:

A = 32 pulses/rev

K = 48 pulses/rev

B = 64 pulses/rev

C = 80 pulses/rev

4.3.2 Safety Features



ZAPI controllers are designed according to the prEN954-1 specifications for safety related parts of control system and to UNI EN1175-1 norm. The safety of the machine is strongly related to installation; length, layout and screening of electrical connections have to be carefully designed. ZAPI is always available to cooperate with the customer in order to evaluate installation and connection solutions. Furthermore, ZAPI is available to develop new SW or HW solutions to improve the safety of the machine, according to customer requirements.
Machine manufacturer holds the responsibility for the truck safety features and related approval.

COMBI AC1 electronic implements a double μC structure. The second μC main task is to check correct functionality of the first μC , whose main task is to control traction AC motor. In more detail:

- first microcontroller manages Ac traction motor control and **hydraulic safety related functions**.
- second microcontroller manages Dc pump motor control, valves control and **traction safety related functions**.

Basically, the two microcontrollers implement a double check control of the main functions.

4.4 EMC



EMC and ESD performances of an electronic system are strongly influenced by the installation. Special attention must be given to the lengths and the paths of the electric connections and the shields. This situation is beyond ZAPI's control. Zapi can offer assistance and suggestions, based on its years experience, on EMC related items. However, ZAPI declines any responsibility for non-compliance, malfunctions and failures, if correct testing is not made. The machine manufacturer holds the responsibility to carry out machine validation, based on existing norms (EN12895 for industrial truck; EN50081-2 for other applications).

EMC stands for Electromagnetic Compatibility, and it represents the studies and the tests on the electromagnetic energy generated or received by an electrical device.

So the analysis works in two directions:

- 1) The study of the **emission** problems, the disturbances generated by the device and the possible countermeasure to prevent the propagation of that energy; we talk about “conduction” issues when guiding structures such wires and cables are involved, “radiated emissions” issues when it is studied the propagation of electromagnetic energy through the open space. In our case the origin of the disturbances can be found inside the controller with the

connected to a key voltage when the operator is present. There are two levels:

- HANDLE: CNA#7 [CNA#1 in AmpSeal] is managed as tiller input (no delay when released).
- SEAT: CNA#7 [CNA#1 in AmpSeal] is managed as seat input (with a delay when released → debouncing function).

2) HOUR COUNTER

This option specifies the hour counter mode. It can be set one of two:

- RUNNING: The counter registers travel time only
- KEY ON: The counter registers when the "key" switch is closed (controller supplied)

3) BATTERY CHECK

This option specifies the handling of the low battery charge detection.

There are four levels:

- Level 0: Nothing happens, the battery charge level is calculated but is ignored, it means no action is taken when the battery is discharged.
- Level 1: BATTERY LOW alarm is raised when the battery level is calculated being less than or equal to 10% of the full charge. The BATTERY LOW alarm inhibits the Lifting function.
- Level 2: BATTERY LOW alarm is raised when the battery level is calculated being less than or equal to 10% of the full charge. The BATTERY LOW alarm reduces the maximum truck speed down to 24% of the full truck speed and it inhibits the Lifting function.
- Level 3: Equivalent to Level 1: a BATTERY LOW alarm is raised when the battery level is calculated being less than or equal to 10% of the full charge. The BATTERY LOW alarm inhibits the Lifting function.

4) STOP ON RAMP

Only when the encoder is present, it is possible to electrically hold the truck on a slope when the accelerator is released but the tiller is not released.

- ON: The stop on ramp feature (truck electrically hold on a ramp) is managed for a time established by AUXILIARY TIME parameter.
- OFF: the stop on ramp feature is not performed. That means the truck comes down slowly during the AUXILIARY TIME.

After this "auxiliary time", the electromechanical brake is applied and the 3-phase bridge is released; if the electromechanical brake is not present the truck comes down very slowly (see the AUX OUTPUT #1 option programming and see also 13.4).

5) AUX OUTPUT #1

This option handles the digital output CNA#31 in AmpSaab connector [CNA#4 in Ampseal connector]. It can be used one of four:

- BRAKE: it drives an electromechanical Brake.
- HYDROCONT: it drives the contactor for a hydraulic steering function when the direction input or brake pedal input are active or a movement of the truck is detected.
- EX.HYDRO: it drives the contactor for a hydraulic steering function when the exclusive hydro input is active
- FREE: it is not used.

The current this output can sink is up to 3Adc.

6) QUICK INVERSION

It can be set:

ON/OFF. This is the level of the CNA#37 digital input (only in AmpSaab connector):

- ON GND = When CNA#37 is not closed to a battery (key) voltage (or connected to GND) the Lift Stop is active.
- OFF +VB = When CNA#37 is closed to a battery (key) voltage the Lift Stop is not active.

25) IN12 SWITCH

ON/OFF. This is the level of the digital input#12 CNA#38 (only in AmpSaab connector):

- ON +VB = When it is closed to a battery (key) voltage the digital input#12 is active.
- OFF GND = When it is not closed to a battery (key) voltage (or it is connected to GND) the digital input#12 is not active.

9.5 Function configuration (SLAVE)

9.5.1 Config menu “SET OPTIONS” functions list

1) HOUR COUNTER

Same function of the hour counter option of the Master. When set RUNNING, the hourcounter counts the working time of the pump motor and of the lowering EVP.

2) EVP TYPE

Analog/digital: defines the type of the EVP electrovalve, current controlled:
Analog: the related output manages a proportional valve, current controlled
Digital: the related output manages an on/off valve

3) EV1 TYPE

Analog/digital: defines the type of the EV1 electrovalve, voltage controlled:
Analog: the related output manages a proportional valve, with a voltage controlled method
Digital: the related output manages an on/off valve.

4) SET TEMPERATURE

NONE/ANALOG/DIGITAL: set the type of sensor for the measurement of the pump motor temperature.

9.5.2 Config menu “ADJUSTMENTS” functions list

1) THROTTLE 0 POINT

Establishes a deadband in the lift/lower accelerator (or, in general, the potentiometer used to command the speed of the motor connected to the slave) input curve.

2) THROTTLE X POINT

This parameter, together with the THROTTLE Y POINT, changes the characteristic of the lift/lower accelerator input curve : when the accelerator is de-pressed to X point per cent, the corresponding truck speed is Y point per cent of the Maximum truck speed. The relationship between the accelerator position and the truck speed is linear between the THROTTLE 0 ZONE and the X point and also between the X point and the maximum accelerator position but with two different slope.

10.4 Description of the throttle regulation

This regulation applies a not linear relationship between the position of the accelerator and the speed of the truck. The main goal is to increase the resolution for the speed modulation when the truck is slowly moving.

Three adjustments are used for the throttle regulation:

- 1) THROTTLE 0 ZONE
- 2) THROTTLE X POINT
- 3) THROTTLE Y POINT

THROTTLE 0 ZONE: the speed of the truck remains at frequency creep meanwhile the voltage from the accelerator potentiometer is lower than this percentage of the MAX VACC setting. This adjustment define the width of a dead zone close to the neutral position.

THROTTLE X POINT & THROTTLE Y POINT: the speed of the truck grows up with a fixed slope (linear relationship) from the THROTTLE 0 ZONE up to THROTTLE X POINT. This slope is defined by the matching between the X point percentage of the MAX VACC setting with the Y point percentage of the full truck speed.

From the X point up to the MAX VACC point, the slope of the relationship between the truck speed and the accelerator position is different (see figure below) to match the full speed in the truck with the MAX VACC voltage in the accelerator position.

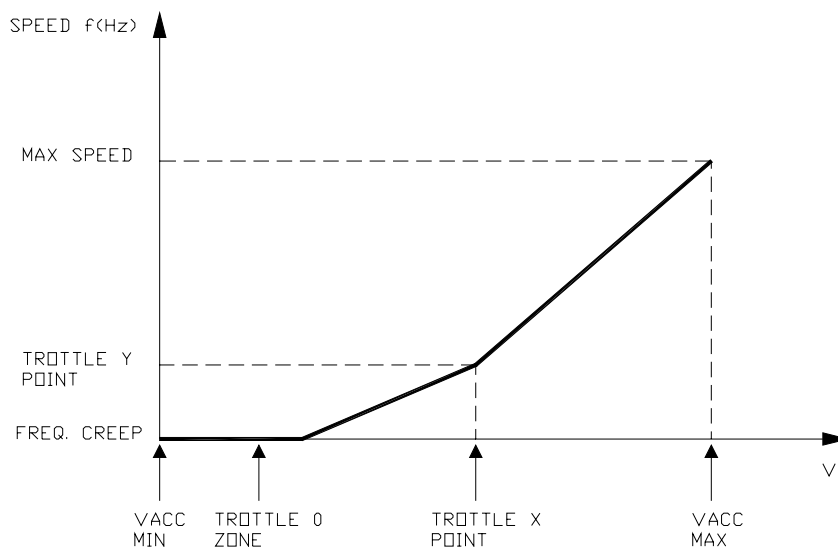

Troubleshooting:

The problem is inside the logic of the inverter, replace the controller.

24) "NO CAN MESSAGE N5"

Cause:

No Can messages from the slave microcontroller.

Troubleshooting:

This alarm could be caused by a canbus malfunctioning, which blinds master-slave communication. Otherwise it is an internal fault of the controller which must be replaced.

25) "WRONG SETPOINT"

Cause:

This is a safety related test. The Master μ C has detected a Slave μ C wrong hydraulic function setpoint.

Troubleshooting:

This is a internal fault of the controller, it is necessary to replace it.

26) "SAFETY FEEDBACK"

Cause:

This is a safety related test. Master μ C has detected a problem on the feedback of EVP driver.

Troubleshooting:

This is a internal fault of the controller, it is necessary to replace it.

27) "VACC OUT RANGE"

Cause:

The voltage on the Vacc potentiometer (A15) is outside of the range that was set with the "Program Vacc" function.

Troubleshooting:

Repeat the "Program Vacc" procedure.

11.9 Analysis and troubleshooting of Slave warnings

- 1) "CURRENT SENSOR LOW"
Cause:
The pump chopper current sensor feedback is too low (below 0.5V).
Troubleshooting:
This type of fault is not related to external components; replace the controller.
- 2) "HW FAULT VALVE"
Cause:
The slave has detected that the master microcontroller is not able to stop hydraulic valves functions
Troubleshooting:
This fault is not related to external components, so it is necessary to replace the controller.
- 3) "VALVE COIL SHORTED"
Cause:
This alarm occurs when there is a short circuit on an on/off valve coil.
Troubleshooting:
A) If the fault is present at start up, it is very likely that the hw overcurrent protection circuit is damaged, it is necessary to replace the controller.
B) If the fault is present when the controller drives the outputs, the problem is located in the harness and in the coils.
- 4) "VALVE DRIVER SHORTED"
Cause:
One or more on/off valve drivers are shorted.
Troubleshooting:
Check if there is a short or a low impedance between the negative of one of those coils and –BATT. Otherwise the driver circuit is damaged and the controller must be replaced.
- 5) "VALVE CONT DRIVER"
Cause:
One or more on/off valve drivers is not able to drive the load (cannot close).
Troubleshooting:
The device or its driving circuit is damaged, replace the controller.
- 6) "EVP DRIVER KO"
Cause:
The EVP valve driver is not able to drive the load (cannot close).
Troubleshooting:
The device or its driving circuit is damaged, replace the controller.
- 7) "PUMP STBY I HIGH"
Cause:
In standby condition (pump motor not driven), the feedback coming from the current sensor in the pump chopper gives a value too high (>0,8).
Troubleshooting:
This type of fault is not related to external components; replace the controller.

14.1	Main menu "ALARMS" list	84
14.1.1	One Blink Alarms.....	84
14.1.2	Two Blinks Alarms	86
14.1.3	Three Blinks Alarms	87
14.1.4	Four Blinks Alarms	90
14.1.5	Five Blinks Alarms	91
14.1.6	Six Blinks Alarms.....	91
14.1.7	Thirty-two Blinks Alarms	92
14.1.8	No Blink Alarms (Warning)	92
14.2	CAN BUS "ALARMS" List.....	93
15	RECOMMENDED SPARE PARTS	94
16	PERIODIC MAINTENANCE TO BE REPEATED AT TIMES INDICATED.....	95
16.1	Testing the faulty detection circuitry	95

APPROVAL SIGNS

COMPANY FUNCTION	INIZIALS	SIGNS
PROJECT MANAGER	MI	
TECHNICAL ELECTRONIC MANAGER VISA	PP	
SALES MANAGER VISA	PN	

Publication N°: **AEMZP0BA**
Edition: **May 2006**

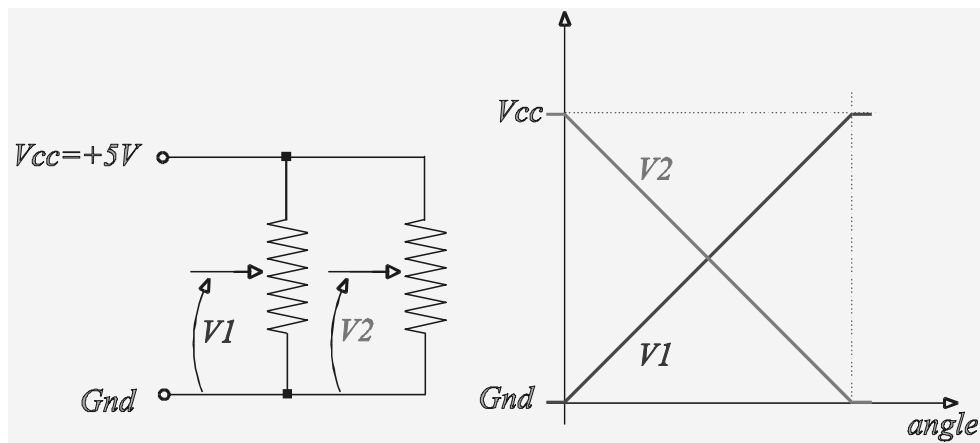

Figure 4-3

The following part numbers resulted suited to work with eps-ac0:

- 1) CONTELEC twin hall sensors 170° Type code VERT-X 2841 417 225.
- 2) BOURNS twin potentiometers 180° Type Code 6657S-466-502.
- 3) MCB twin potentiometers 85° Type Code PMR 410 or PMR426.

The CONTELEC is without brushes but drains a high level of current (about 15 mA). The MCB has the advantage of a spring in the shaft. This spring neutralizes the dead zone in the tiller side getting a strongly accurate straight-ahead matching; unfortunately MCB has a limited angle (85°).

Obviously, the above information states only these parts are suited for the eps-ac0; no reliability evaluation is given here.

Other sources are possible on request, but must be tested for approval.

4.5 Feedback sensors

Feedback sensors are mandatory to close the loop in manual mode if a twin pot is mounted on the steering wheel.

Feedback sensors are strongly suggested (to improve safety) in manual mode if a stepper motor is mounted on the steering wheel (open loop).

Eps-ac0 may handle two different configurations for the feedback sensors:

- 1) Incremental encoder in the motor shaft together with a feedback potentiometer on the steered wheel.
- 2) Incremental encoder in the motor shaft together with one (or two) toggle switch(es) in the straight ahead (and 90 degrees) position of the steered wheel.

On request, in the closed loop application only, eps-ac0 may work also with two encoders in the motor shaft together with a straight ahead toggle switch.

4.5.1 Encoder in the motor shaft and a Feedback Potentiometer

One possible arrangement for the feedback sensor consists of (see Figure 4-4):

- 1) Feedback encoder in the motor shaft.
- 2) Feedback potentiometer on shaft of the steering motor gear box.

7 CONNECTIONS: SUGGESTIONS AND CAUTIONS

Read the following suggestions to get a correct connection of the steering equipment.

7.1 Stepper Motor connections

The stepper motor has 4 connections: two are the stepper motor channels (CNA#9 and CNA#8) and two are the common (negative) references (CNA#10 and CNA#11). In the past we had 6 wires connected between stepper motor and eps-ac. We consider this 4-wire connection fulfils the norm because it is still possible to detect all of the single stepper motor electrical fault.



Note: The stepper motor should be connected with two distinct common (negative) references (CNA#10 and CNA#11). We advice against using just one common wire. That is because it takes long delay to detect when a single common wire is broken.

7.2 Twin pot connections

The twin pot is connected, in alternative to the stepper motor, between CNB#5 (PPOC: 5 V positive supply), CNA#10 (negative supply), CNA#9 (CPOC1: 1st wiper), CNA#8 (CPOC2: 2nd wiper). CNB#5 is connected to a 5 Vdc supply source through a 22 ohms resistance. Take care the supply current of the Twin pot stays lower than 5 mA.

7.3 Encoder connections

The encoder may be supplied either with 5 Vdc or 13 Vdc (factory set jumper J8) on CNB#4 (default set is 5 Vdc on CNB#4). A 10 ohms resistance is connected between the internal supply source and the pin CNB#4. The encoder outputs may be either open collector NPN type or Push-Pull type.

7.4 Feedback pot connections

When a feedback pot is adopted it will be connected between CNB#2 (PPOT: positive supply), CNB#1 (NPOT: negative supply), CNB#6 (CPOT: wiper). Pay attention, inside the eps-ac0, a 470 ohms resistance is connected between PPOT and 5 V supply and also between NPOT and the minus battery. That is done

- 1) Emission
- 2) Electromagnetic Immunity
- 3) ESD rejection.



When possible it is strongly recommended preventing Emission and Immunity problems by locating the controllers inside a metallic enclosure. In most cases, a truck with a metallic enclosure will avoid EMC problem.

8.9.1 Emission

Emission refers to the electromagnetic disturbances that the device generates in the surrounding space. Countermeasure should be adopted to prevent the propagation of those disturbances. We talk about “conduction” issues when guiding structures such wires and cables are involved; “radiated emissions” issues when it is studied the propagation of electromagnetic energy through the open space. In our case the origin of the disturbances can be found inside the controller with the switching of the mosfets which are working at high frequency and generate RF energy. **Wires and cables are responsible for the spreading of this RF disturbance because they works as antennas**, so a good layout of the cables and their shielding can solve the majority of the emission problems.

Three ways can be followed to reduce the emissions:

- 1) **SOURCE OF EMISSIONS:** finding the main source of disturbs and works on it.
- 2) **SHIELDING:** enclosing contactor and controller in a shielded box; using shielded cables.
- 3) **LAYOUT:** a good layout of the cables can minimize the antenna effect; cables running nearby the truck frame or in iron channels connected to truck frame is generally a suggested not expensive solution to reduce the emission level.

8.9.2 Electromagnetic Immunity

The **electromagnetic immunity** concerns the susceptibility of the controller to external electromagnetic fields and their influence on its correct work made. These tests are carried out at determined levels of electromagnetic fields, to simulate external undesired disturbances and verify the electronic device response. Here are some suggestions to improve the electromagnetic immunity:

- 1) **SHIELDING:** enclosing controller and wiring when possible on a shielded box; using shielded cables.
- 2) **LAYOUT:** hide the exposed wires, which are connected to the controller, behind metallic part working like natural barriers.
- 3) **FERRITES:** embrace the exposed wires, connected to the controller, with a split or solid ferrite.
- 4) **BY-PASS CAPACITOR:** connect an interference suppression capacitor (Y type) between the minus battery and the truck frame, as close as possible to the controller.

8.9.3 ESD

When an accumulation of charge occurs in a part insulated from the ground, it may discharging in a shot when turning in contact with a part having different potential. This phenomenon is called Electrostatic Discharge (ESD).

In forklift trucks applications, special attention should be adopted for avoiding ESD. **The main rule is that it is always much easier and cheaper to avoid ESD from being generated, than to increase the level of immunity of the electronic devices.**

position. If present, the minimum of the FB ENC is recorded too (although it is not shown in the hand set).

- Step16** Set FEEDBACK DEVICE to OPTION#3 (feedback pot, feedback encoder and straight ahead toggle switch) and recycle the key to enable the steering by encoder.
- Step17** When FEEDBACK DEVICE is OPTION #3, it is necessary to seek a falling edge on the SW1 (CNA#3) corresponding at the straight ahead position. This is done by moving the steered wheel toward a falling edge of the straight ahead switch. Depending by the shape of the iron plate to act the straight ahead sensor, the falling edge may occur either in a CW or in a CCW rotation. If the iron plate in your arrangement generates a sole rising edge in present steering direction, it is possible to reverse the turning direction of the steered wheel during the initial alignment. To do that an OPTIONS called POT UP SW1 EDGE is supplied. When it is ON, the steered wheel seeks the falling edge during an initial automatic rotation in the direction of an increasing FB POT. When it is OFF, the steered wheel seeks the falling edge during an initial automatic rotation in the direction of a decreasing FB POT. (A properly setting of POT UP SW1 EDGE is required to avoid EPS NOT ALIGN alarm).
- Step18** When FEEDBACK DEVICE is OPTION #3, it is necessary to autoacquire the FB POT value at the matching with the falling edge on the straight ahead switch (SW1). To do that, enter the SET FBPOT AT SW1 setting in the adjustments menu. Save and recycle the key. After the acquisition, the SET FBPOT AT SW1 value should be close to the 2.5 V value; otherwise it is necessary to re-make the FB POT mounting in such a way its wiper is close to 2.5 V at the matching with the falling edge on SW1.
- Step19** Carry out the complete set-up procedure (see 11.1).

10.3 Stepper Motor with Encoder and Feedback pot: one shot installation procedure

This procedure is relative to the connecting drawings Figure 6-2. It describes the step by step installation procedure to get the prototype working in manual mode: to raise the AUTC function it is necessary to make the complete set-up procedure (see topic 11).

For every truck released on the field, the default set-up shall reply the prototype settings and so no installation procedure is required except for the acquisition of the limiting position (see the quick set-up 11.2).

Carry out the procedure in the following order.

- Step1** Connect the AC motor phases in such a way the phase references U, V, W on the steering motor correspond to the terminals references (U, V, W) on the eps-ac0.
- Step2** In the SET MODEL menu set the SYSTEM CONFIG setting to LEVEL 0 to steer in open loop with a stepper motor in manual mode. Turn off and on the key in order the setting is acquired.
- Step3** Set the FEEDBACK DEVICE to OPTION #1 to specify your feedback solution is the sole FEEDBACK POT. Switch off the key after the change. (It is necessary to start with the sole feedback pot to avoid a POSITION ERROR due to the unknown scaling between the encoder counting and the feedback pot value before of an encoder learning operation - Step 12 and 14 below).
- Step4** Set option ENCODER CONTROL to OFF.

12.3.2 RTC with Encoder and Feedback pot

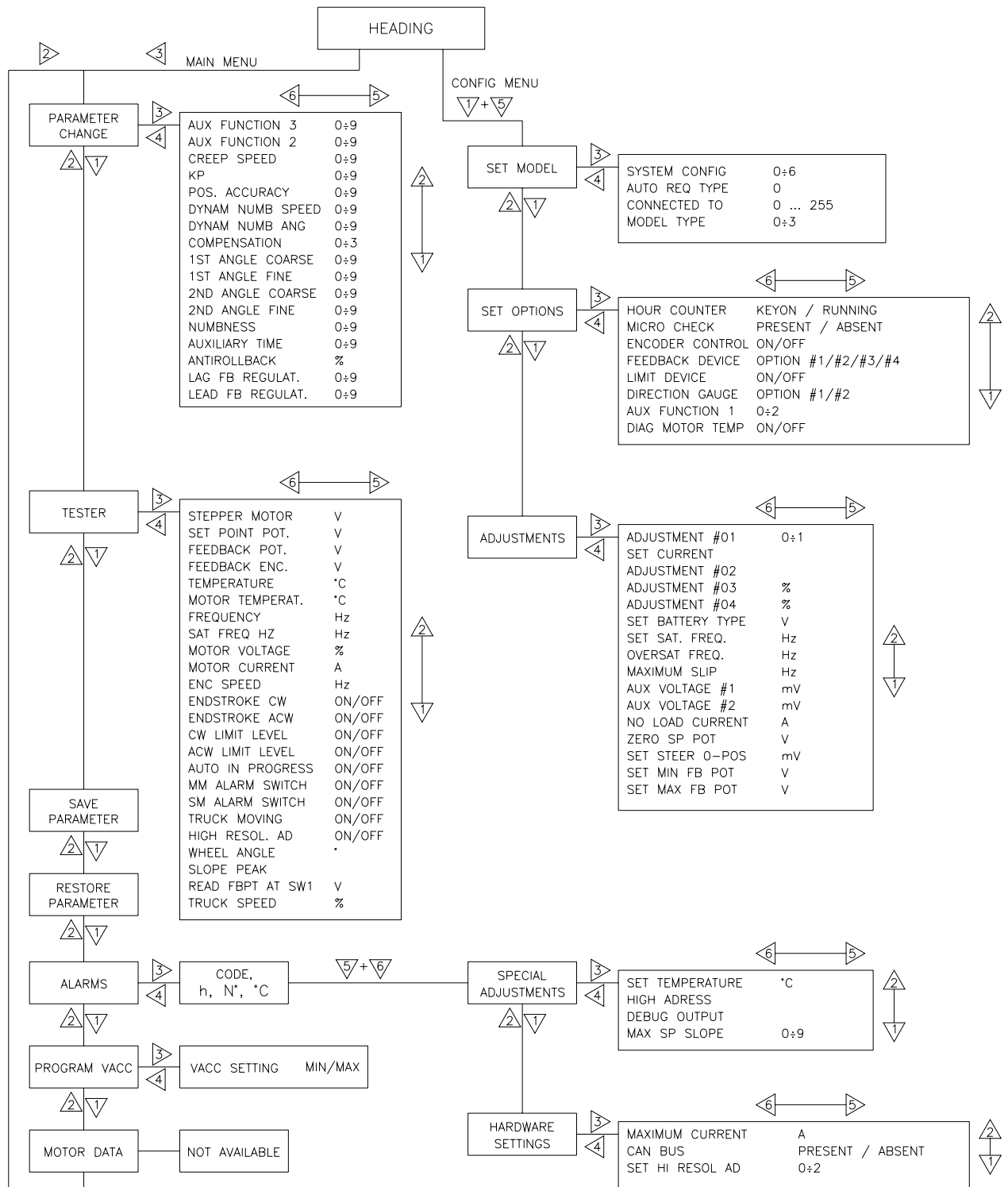

Figure 12-3

12.4.3 Config menu “SET MODEL” functions list

To enter the CONFIG MENU it is necessary to push in the same time the right side top and left side top buttons. Then roll until the SET MODEL item appears on the hand set display. Push the ENTER button (see the Figure 12-7 below).

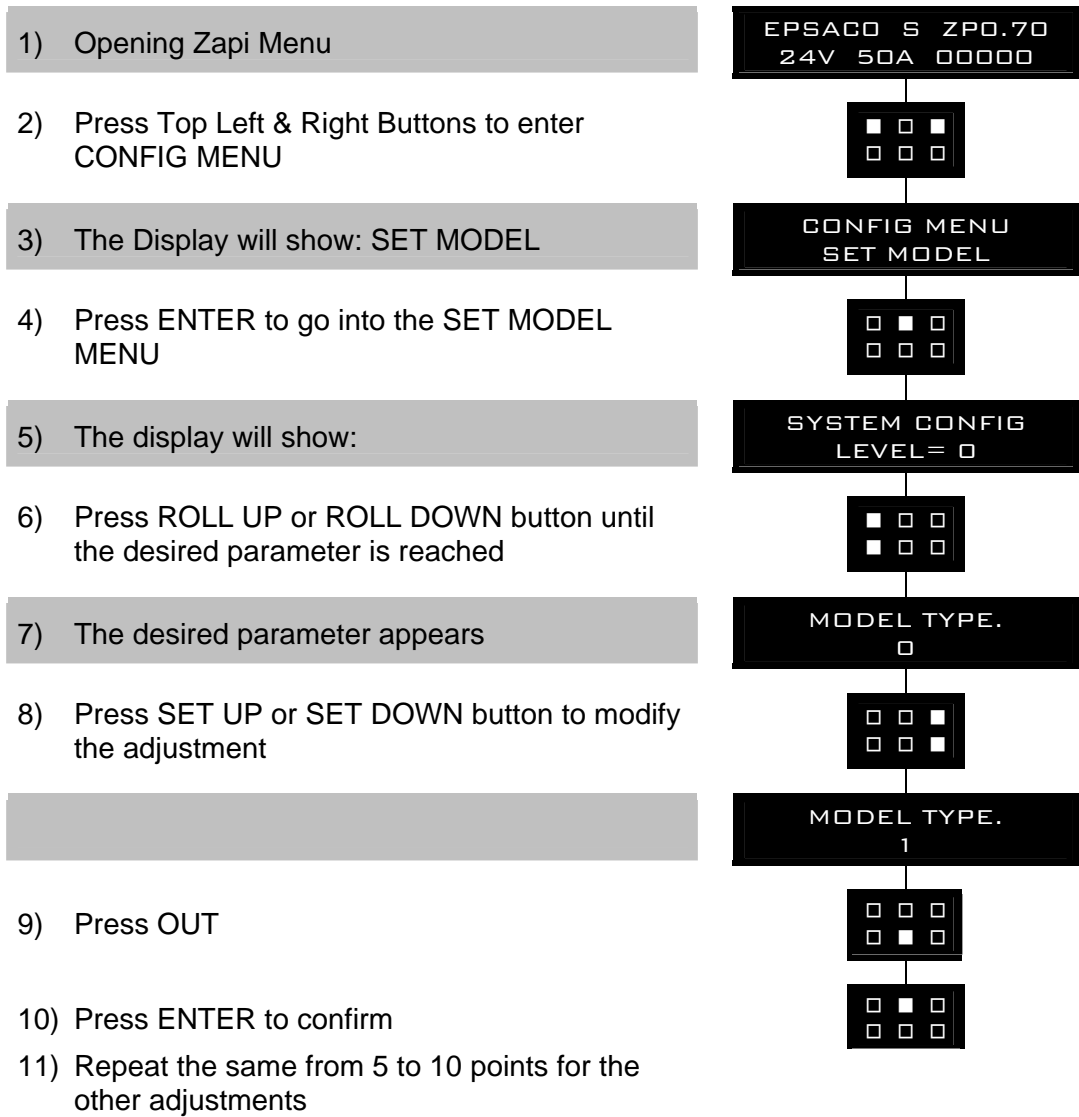

Figure 12-7

12.4.5 Zapi menu “HARDWARE SETTINGS” functions list

To enter this Zapi hidden menu a special procedure is required. Ask this procedure directly to a Zapi technician.

1) MAXIMUM CURRENT

MAXIMUM CURENT sets the limit for the current in the controller.

2) CAN BUS

ABSENT or PRESENT. This setting specifies whether the eps-ac0 is CAN Bus connected or not. When CAN BUS is ABSENT, the CAN BUS KO alarm is inhibited together with any starting sequence used to synchronize via CAN Bus the eps-ac0 with the other controllers.

3) SET HI RESOL AD

When it is set to Level 1, enables an analog to digital conversion with high resolution applied to the command pot CPOC1. Level 0 means the high resolution AD conversion is inhibited. Level 2 is not used.

4) MICRO SLAVE #8

CAN Bus Code = 212

- Cause: It occurs when the encoder counting of the main uC is not matched with the encoder counting of the slave uC.
- Remedy: It is necessary to replace the controller.

5) INPUT ERROR #1

CAN Bus Code = 99

- Cause: It occurs when the voltage on CNA#4 (NK1: Lower Potential Terminal of the Safety Contacts (see 7.6) is higher than 12 V before to turn the safety contacts closed.
- Remedy: When the safety contacts are open, the voltage on CNA#4 is expected to be close to 0 Vdc and this is independent from whether the safety contacts are connected to a plus battery or to a minus battery (see 7.6). In the first case (safety contacts connected to a plus battery), when the safety contacts are open, CNA#4 is connected to a minus battery through a load. Only a harness mistake may connect NK1 to a higher than 12 V voltage.

6) SERIAL ERR #1

CAN Bus Code = 6

- Cause: Main uC and Slave uC communicate via a local serial interface. This alarm occurs when the slave uC does not receive the communication from the main uC through this serial interface.
- Remedy: It is necessary to replace the controller.

7) SLAVE COM. ERROR

CAN Bus Code = 227

- Cause: Main uC and Slave uC communicate via a local serial interface. This alarm occurs when the main uC does not receive the communication from the slave uC through this serial interface.
- Remedy: It is necessary to replace the controller.

8) NO SYNC

CAN Bus Code = 226

- Cause: Every 16msec, inside the code cycle, the main uC rises and then lowers an input for the slave uC (SYNC). When the slave uC detects no edge for more than 100 msec on this input, this alarm occurs. This is just a watch dog function: when the main uC does not execute the code cycle it does not update the SYNC signal and the slave uC cuts off the steer and traction.
- Remedy: It is necessary to replace the controller.

9) KM CLOSED

CAN Bus Code = 253

- Cause: This alarm occurs at key on if the slave uC detects the safety contact, of the main uC, closed prior to be commanded.
- Remedy: This alarm occurs if the connection CNA#5 (K1) is around a voltage of 12 Vdc when switching on the key. In fact, when the safety contacts are open, K1 is expected being connected to a battery voltage (not 12 V). Search for a harness problem or replace the controller.

10) KM OPEN

CAN Bus Code = 251

CLICK HERE TO **DOWNLOAD** THE COMPLETE MANUAL

- Thank you very much for reading the preview of the manual.
- You can download the complete manual from: www.heydownloads.com by clicking the link below



- Please note: If there is no response to CLICKING the link, please download this PDF first and then click on it.

CLICK HERE TO **DOWNLOAD** THE COMPLETE MANUAL