



# Service Manual

## MicroCommand Control System

<b>M70D</b>	36/48 VOLT	72/80 VOLT
	7FG00600	3CJ00600
	A1EC4-60200	A1EC4-80200
<b>M80D</b>	7FG00600	3CJ00600
	A1EC4-60200	A1EC4-80200
<b>M100D</b>	8AG00600	4AJ00600
	A1EC4-60200	A1EC4-80200
<b>M120D</b>	8AG00600	4AJ00600
	A1EC5-60200	A1EC5-80200

CLICK HERE TO **DOWNLOAD** THE COMPLETE MANUAL

- Thank you very much for reading the preview of the manual.
- You can download the complete manual from: [www.heydownloads.com](http://www.heydownloads.com) by clicking the link below



- Please note: If there is no response to CLICKING the link, please download this PDF first and then click on it.

CLICK HERE TO **DOWNLOAD** THE COMPLETE MANUAL

# Systems Operation

## Glossary

**Accelerator** - A device that converts mechanical movement into a digital voltage pattern to the logics for variable drive motor speed.

**Activate** - Word used with a component or circuit. It means to change from the normal condition to the "activated" condition because of an application of force or electricity.

**Ammeter** - An electric meter used to measure current flow in amperes.

**Ampere (or Amp)** - The unit of measurement of current flow. The amount of current that one volt can push through a resistance of one ohm.

**Analog to digital converter** - A device that converts an analog voltage signal into a series of digital HIGH and LOW voltage signals.

**Anode** - The positive (+) side of a diode.

**Armature** - The rotating portion of an electric motor or generator.

**Base** - The terminal of a transistor through which control current flows (see Transistor).

**Battery** - Two or more cells connected together for a supply of electric current.

**BDI** - Battery Discharge Indicator - An electrically controlled display showing the operator the state of battery charge.

**Brush** - A conductor, normally a block of carbon, that makes sliding contact between the stationary and moving part of the motor or generator.

**Bus Bar** - A heavy electrical conductor to which other smaller wires are connected.

**Capacitor** - Device used to store electrical energy for short periods of time.

**Cathode** - The negative (-) side of a diode.

**Circuit** - A way for current to go from the positive (+) side of an electrical power source to the negative (-) side of the electrical power source. This can be through wires and electrical components.

**Coil** - A component made from many circles or turns of wire used to concentrate a magnetic field.

**Collector** - A terminal of a transistor through which main current flows (see Transistor).

**Commutator** - An armature component used to transfer current from the brushes to the armature windings.

**Compound Motor** - A motor which has a field winding in series with the armature and a shunt field winding in parallel with the series winding and armature.

**Compound/Series Motor** - Similar to a compound except the parallel shunt field windings are controlled on and off to vary speed and torque.

**Conduct** - To allow the flow of current.

**Conductor** - A material that allows a path for current flow.

**Connector** - Part of a wire assembly or harness that connects to another wire assembly or harness. Used for ease of assembly and disassembly.

**Contact Assembly** - An electrical component consisting of an electromagnetic coil and a set of heavy contact tips. Control current passes through the coil, building a magnetic field that opens or closes the contact tips.

**Contact Coil** - An electromagnet used to close or open contact tips in a contactor assembly.

**Contact Tips or Contacts** - The portion of a switch, relay, or contactor where the circuit can be opened or closed.

**Continuity** - Having the ability to allow current flow.

**Control Circuits** - The wires and components carrying low current to signal the logics unit, turn on main components, or support auxiliary circuits (indicated by narrow lines on a schematic).

**Counter Electromotive Force (CEMF)** - An opposing voltage set up by a collapsing or increasing magnetic field within a coil.

**Current** - The movement or flow of electricity through a conductor. A circuit must be complete for current to flow.

# Programming Features

To change individual features, use the following procedure:

1. Place the DIAG/RUN/SETUP switch in the SETUP position.
2. Move the direction lever to neutral.
3. Turn the key switch to ON.
4. The display should show a flashing "0". This indicates that feature "0" is selected.
5. Cycling the DIAG/RUN/SETUP switch from SETUP to RUN to SETUP advances the display to the next feature number. Cycle the DIAG/RUN/SETUP switch until the feature number of the parameter to be programmed is flashed on the display.
6. With the desired feature number flashing, move the direction lever to forward. The display will stop flashing the feature number and will show the value to which the feature is set.
7. To increase the value, cycle the direction lever to neutral then back to forward. The number shown on the display will increment one number. Repeat the cycle until the desired value for the feature is shown.  
  
To decrease the value, cycle the direction lever to neutral then to reverse. The number shown on the display will increment one number. Cycle the lever from neutral to reverse until the desired value for the feature is shown.
8. After setting the desired value for a feature, move the DIAG/RUN/SETUP switch to the RUN position to program the value. If other feature numbers need to be programmed, move the DIAG/RUN/SETUP switch to the SETUP position. The next feature number will flash on the display. Cycle the DIAG/RUN/SETUP switch as in step 5 until the desired feature number flashes on the display. A flashing "d" indicates the end of the feature list. To return to the start of the feature list, recycle the key switch.

After programming any features, test the lift truck to verify that the operation is correct.

# Logic Unit

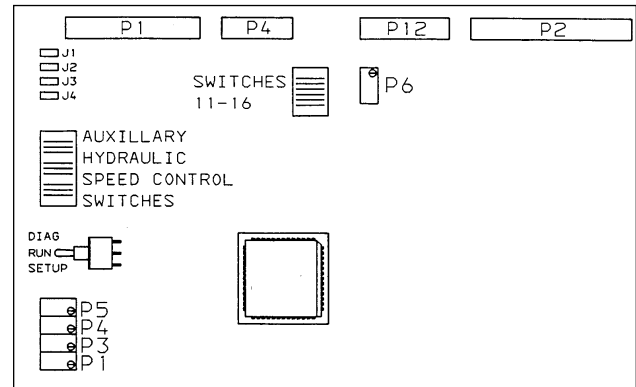

Components on Logic Unit (Logics)

The logic unit (logics) has one printed circuit board contained in a vertical sheet metal box on the control panel. Most of the circuitry on the board conditions voltage signals into and out of the microprocessor. Software in the microprocessor controls logics outputs for: power components in the hydraulic pump system and drive system, contactor coils and the instrument panel display. Access to the board is provided by four lock screws that allow the cover to be removed.

With the cover removed, access is provided to the DIAG/RUN/SETUP switch, options jumpers (J1, J2, J3, and J4), auxiliary hydraulic speed control switches (SW2-SW10), option switches (SW11-SW15) and adjust potentiometers, P1 for current limit, P3 for regenerative braking, P4 for speed limit current, P5 for the Battery Discharge Indicator (BDI) and P6 for bypass dropout.

## Option Jumpers And Switches

Option jumpers and switches are used to match the logics to a specific truck application. Remove the logics cover to access the jumpers.

Jumper J1 should be installed for the 36V lift trucks.

Jumper J2 should be installed for 48V lift trucks.

Jumper J3 should be installed for 72V lift trucks.

Jumper J4 should be installed for 80V lift trucks.

# Power Steering Idle Transistor T1P, T2P And T3P Pulsing

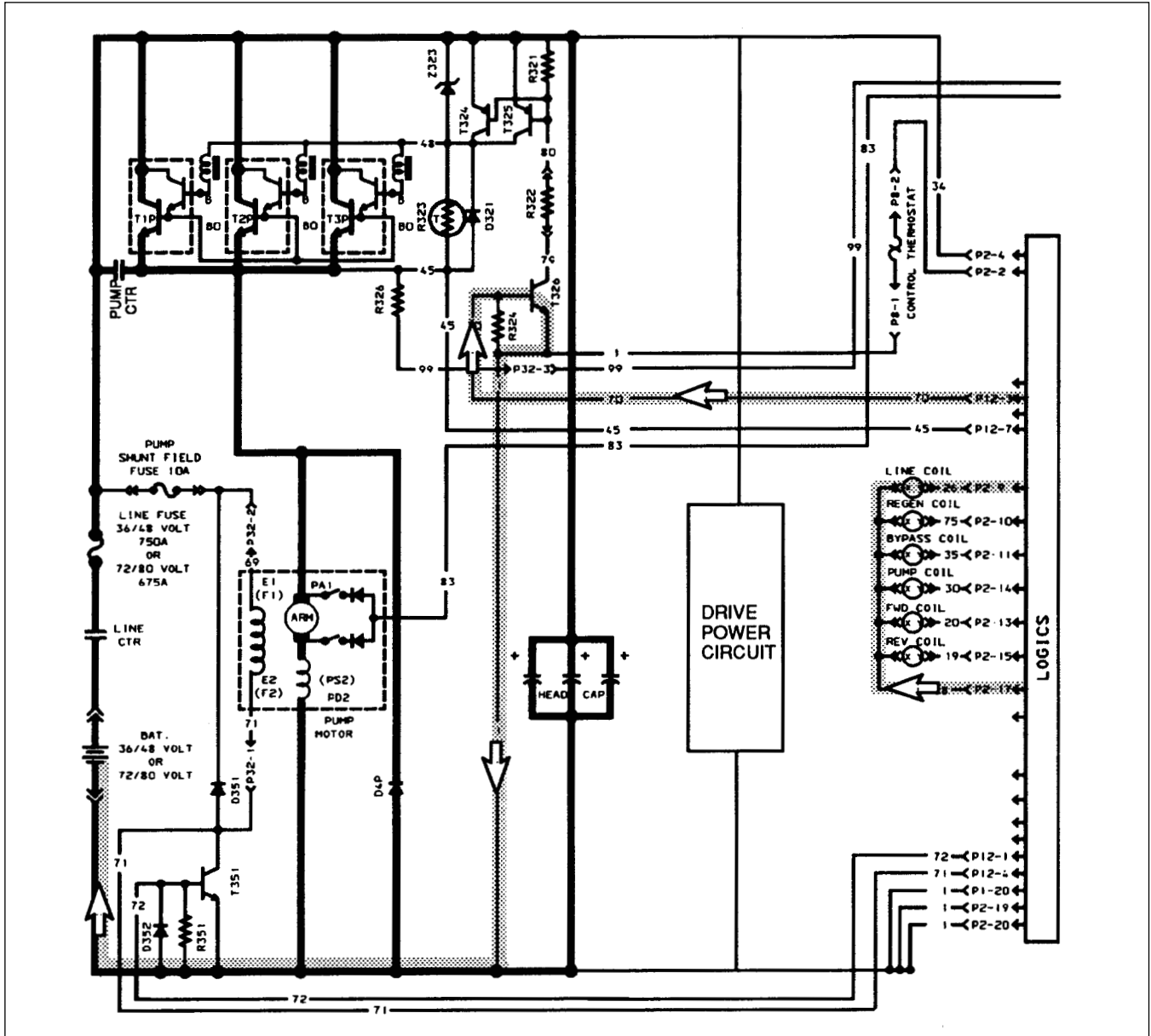

T326 Base Input Signal

**NOTE:** The 72/80V trucks have only two pump and two drive power transistors instead of the three that 36/48V trucks have.

After the line contactor is closed, the logics generates a positive pulsing signal (approximately 1.5 volts) on P12-3, to the base of transistor T326. This is a rapidly changing signal that can be viewed only on an oscilloscope. Because T326 is an NPN

type transistor, the positive signal to the base causes current flow through the base/emitter junction. When current flows through the base/emitter junction, the transistor turns ON and main current will flow through the collector/emitter junction. If the base signal from the logics is ON at T326, T326 will be ON. When the base signal is OFF, T326 will be OFF.

## Tilt And Auxiliary Control Circuit

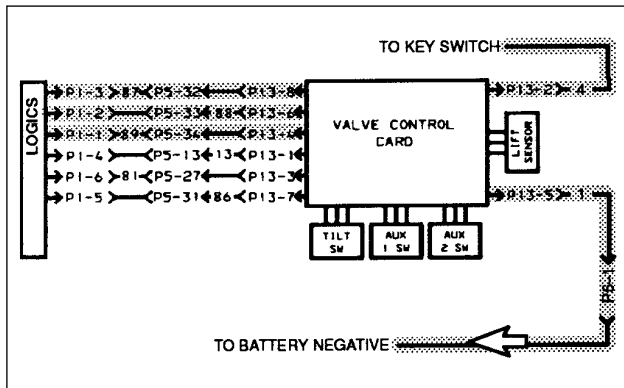

Tilt And Auxiliary Control Circuit

The tilt and auxiliary control functions are controlled by separate logic inputs P1-1 (tilt), P1-2 (Aux. 1) and P1-3 (Aux. 2). A separate Hall-effect switch is used for each function. Each switch will connect its respective logics input to battery negative when activated. The logics will then control the power transistors, shunt field and pump contactor in the hydraulic power circuit to control the pump motor to a preset speed.

Each function (Tilt, Aux 1, Aux 2) can be preset at any one of the seven pump motor speeds or OFF. The speeds are set by nine auxiliary hydraulic speed control switches (SW2 through SW10) on the logics board. Three switches (SW2, SW3 and SW4) control tilt speed. Three switches (SW5, SW6 and SW7) control Aux. 1 speed. Three switches (SW8, SW9 and SW10) control Aux. 2 speed. The chart that follows shows how the auxiliary hydraulic speed control switches relate to hydraulic motor speed.

TILT SWITCH SETTINGS						
Motor Speed	Tilt SW2	Tilt SW3	Tilt SW4	T351	T1P, T2P, T3P	Lift Contactor
OFF	Open	Closed	Open	OFF	OFF	Open
1	Open	Open	Open	Full ON	30% Pulsing	Open
2	Closed	Open	Open	Full ON	37% Pulsing	Open
3	Closed	Closed	Open	Full ON	50% Pulsing	Open
4	Closed	Closed	Closed	Full ON	69% Pulsing	Open
5	Closed	Open	Closed	Full ON	87% Pulsing	Open
6	Open	Open	Closed	Full ON	OFF	Closed
7	Open	Closed	Closed	OFF	OFF	Closed
AUX 1 SWITCH SETTINGS						
Motor Speed	Aux 1 SW5	Aux 1 SW6	Aux 1 SW7	T351	T1P, T2P, T3P	Lift Contactor
OFF	Open	Closed	Open	OFF	OFF	Open
1	Open	Open	Open	Full ON	30% Pulsing	Open
2	Closed	Open	Open	Full ON	37% Pulsing	Open
3	Closed	Closed	Open	Full ON	50% Pulsing	Open
4	Closed	Closed	Closed	Full ON	69% Pulsing	Open
5	Closed	Open	Closed	Full ON	87% Pulsing	Open
6	Open	Open	Closed	Full ON	OFF	Closed
7	Open	Closed	Closed	OFF	OFF	Closed
AUX 2 SWITCH SETTINGS						
Motor Speed	Aux 2 SW8	Aux 2 SW9	Aux 2 SW10	T351	T1P, T2P, T3P	Lift Contactor
OFF	Open	Closed	Open	OFF	OFF	Open
1	Open	Open	Open	Full ON	30% Pulsing	Open
2	Closed	Open	Open	Full ON	37% Pulsing	Open
3	Closed	Closed	Open	Full ON	50% Pulsing	Open
4	Closed	Closed	Closed	Full ON	69% Pulsing	Open
5	Closed	Open	Closed	Full ON	87% Pulsing	Open
6	Open	Open	Closed	Full ON	OFF	Closed
7	Open	Closed	Closed	OFF	OFF	Closed

**NOTE:** Refer to the Testing And Adjusting section for specific setup instructions of the auxiliary hydraulic speed control switches.

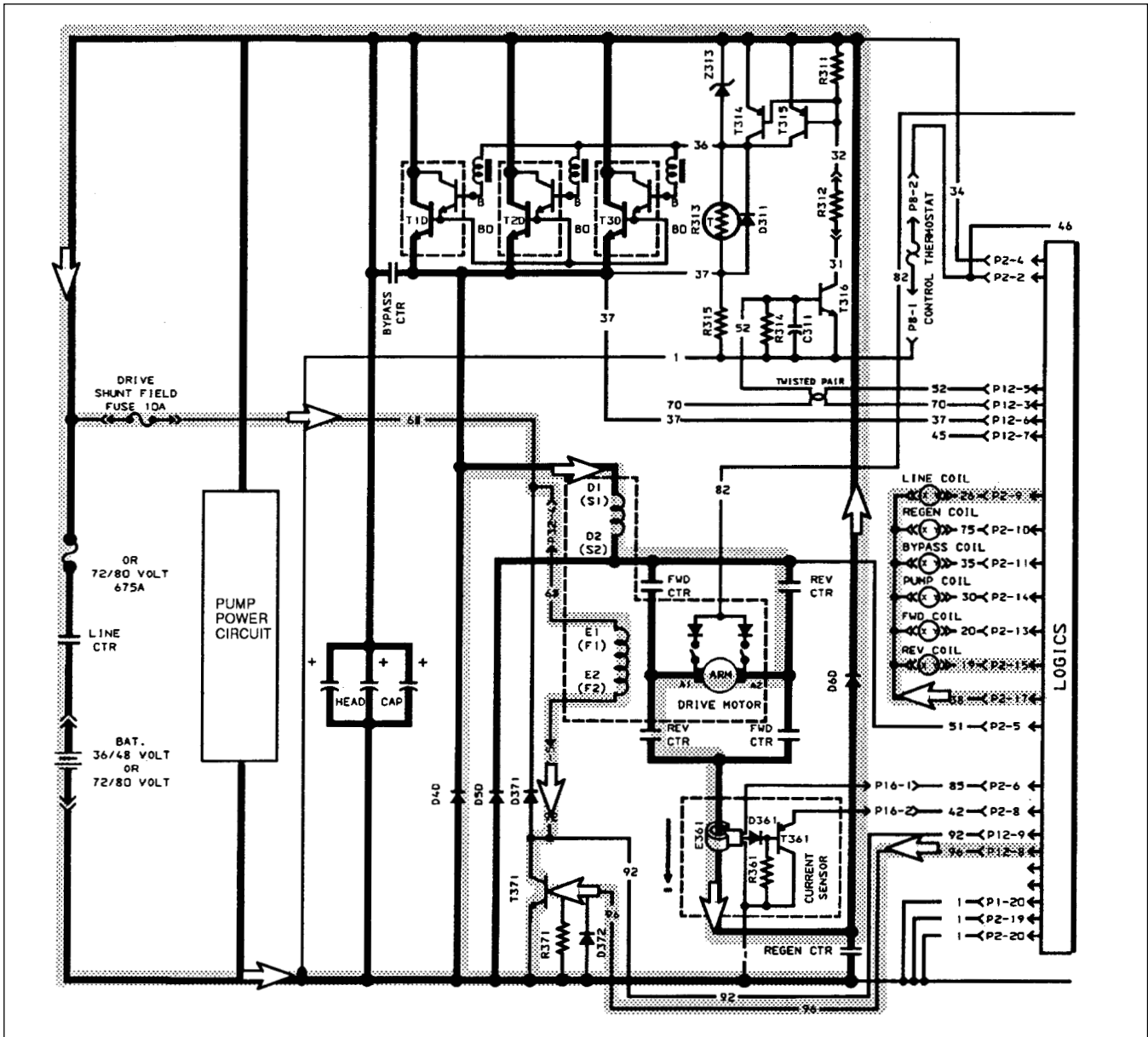

Regenerative Circuit (Power Transistors OFF)

When current peaks at its preset value, the logics will turn OFF the power transistors. The generated current will flow from the drive motor field and armature, through the current sensor, D6D, line fuse, line contactor tips, battery, flyback diode D4D back to the drive motor field. This is the charging cycle for the battery. When the current decreases,

the logics will turn ON the power transistors, and the cycle starts again.

As electrical braking slows the truck, the motor generates less and less current. The logics makes up for the decreasing generated current by increasing the pulse rate of the power transistors.

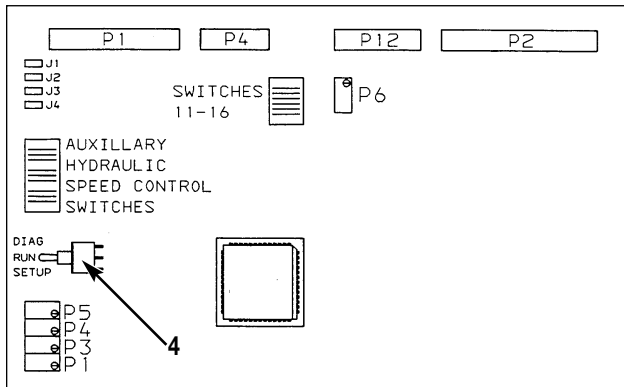

RUN/DIAG/SETUP Switch Location  
(4) Switch.

6. Move switch (4) to the DIAG position. This places the controller in diagnostics when the battery is connected and the key is turned to ON. If any of the tests that follow fail (except the line fuse test where the Display = "d"), continue through the tests that remain. Move switch (4) to RUN and then back to DIAG. This will bypass the failed test and allow the next test to be performed.

7. Connect the battery and turn the key to ON.

Display = "blank" See Troubleshooting Problems 1 or 2.

Display = "d" Line fuse not disconnected or head capacitor not discharged below 5 volts. Return to Step 2.

Display = "E" or "F" Logics failure. Replace logics.

**NOTE:** This test does not check all the logics circuits, so the logics may pass this test and still have a failure.

Display = "1" Ready for Test 1.

### Test 1: Seat Switch

Press and release the seat to close and open the seat switch.

Display = "1" Seat switch circuit defect. Move hand around on seat and press again. If still "1", see Troubleshooting Problem 27.

Display = "2" Seat switch circuit OK.

### Test 2: Direction Switch

Move the direction switch from neutral to reverse to forward.

Display = "2" Direction switch circuit defect. See Troubleshooting Problem 28.

Display = "3" Direction switch circuit OK.

### Test 3: Lift Sensor

Pull the lift lever to maximum, then release.

Display = "3" Lift sensor circuit is defective or out of adjustment. See Troubleshooting Problem 29.

Display = "0" (Flashing) Lift circuit OK. Display now shows the speed that the lift lever is set to. As the lever is pulled back, 0 through 7 will be shown. This indicates at what position the lift lever changes the pump motor speed. The flashing mode must be overridden by switching the RUN/DIAG/SETUP switch to RUN and then back to DIAG.

### Test 4: Tilt And Auxiliary Switches

Pull the tilt lever to maximum, then release.

Display = "4" Tilt switch is defective or out of adjustment. See Troubleshooting Problem 30.

Display = "5" Tilt switch circuit OK.

Pull auxiliary 1 lever to maximum, then release. (If there is no auxiliary 1 lever, use the tilt lever.)

Display = "5" Auxiliary 1 switch circuit is defective or out of adjustment. See Troubleshooting Problem 30.

Display = "6" Auxiliary 1 switch circuit OK.

Pull auxiliary 2 lever to maximum, then release. (If there is no auxiliary 2 lever, use the tilt lever.)

Display = "6" Auxiliary 2 switch circuit is defective or out of adjustment. See Troubleshooting Problem 30.

Display = "0" (flashing) Tilt and auxiliary switch circuits OK. The display now shows the speed that the tilt or the auxiliary levers are set to. (See Tilt And Auxiliary Adjustment Procedure to set speeds.) As each lever is pulled back, the speed it is set to will be shown. This also indicates at what position the lever turns on the hydraulic pump motor. The flashing mode must be overridden by switching the RUN/DIAG/SETUP switch to RUN and then back to DIAG.

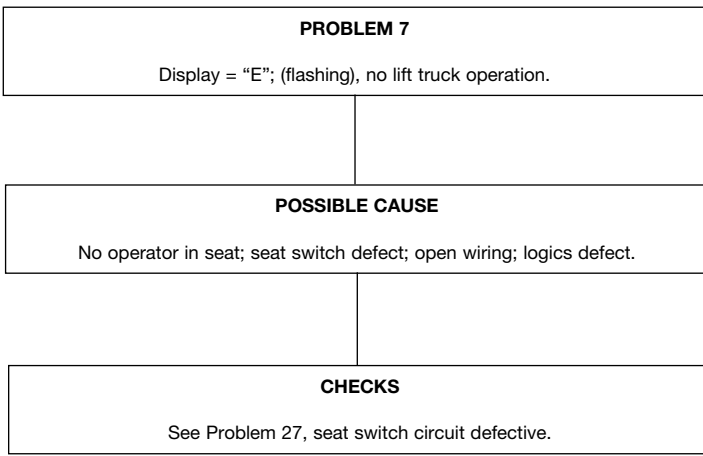
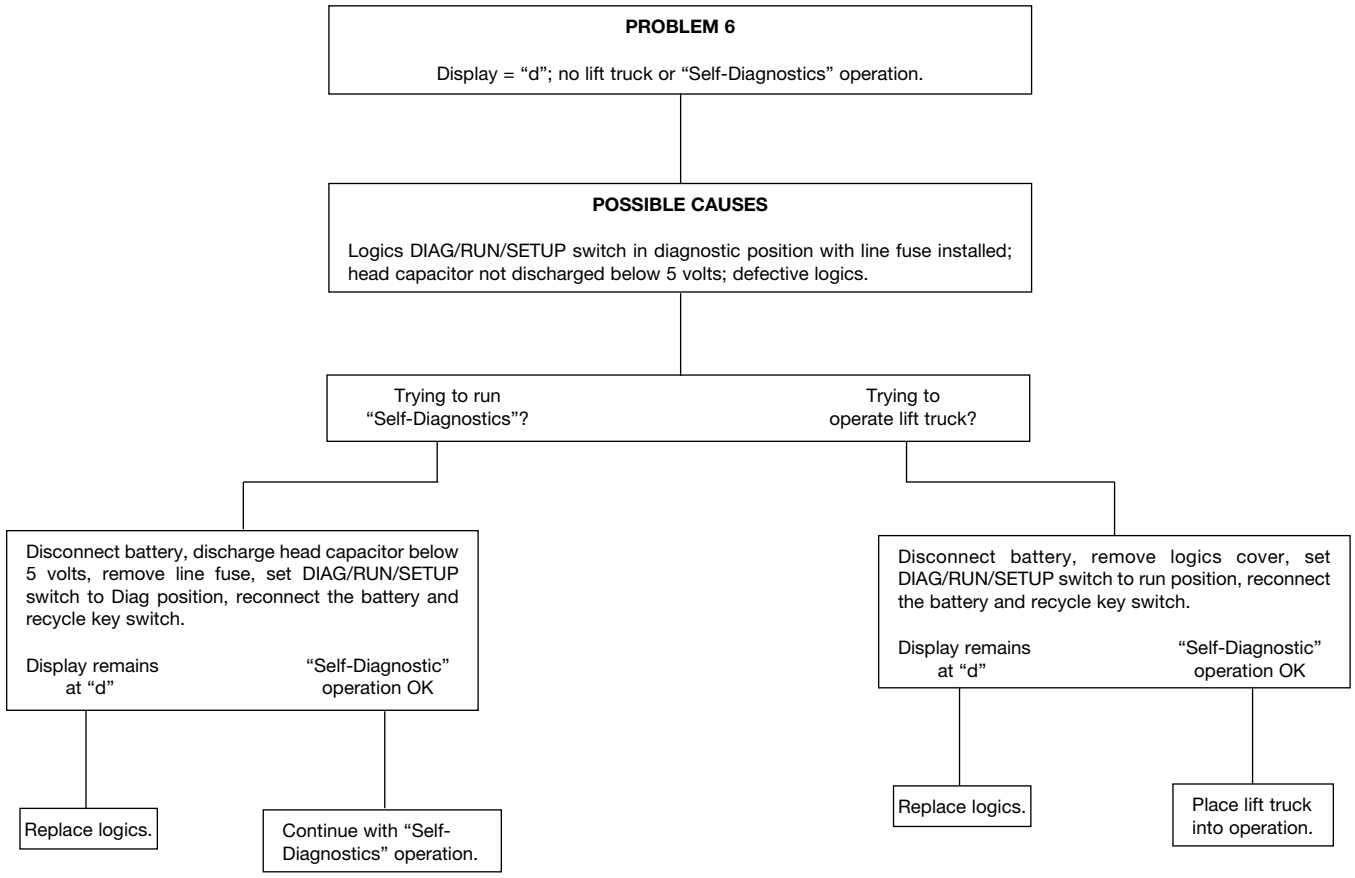

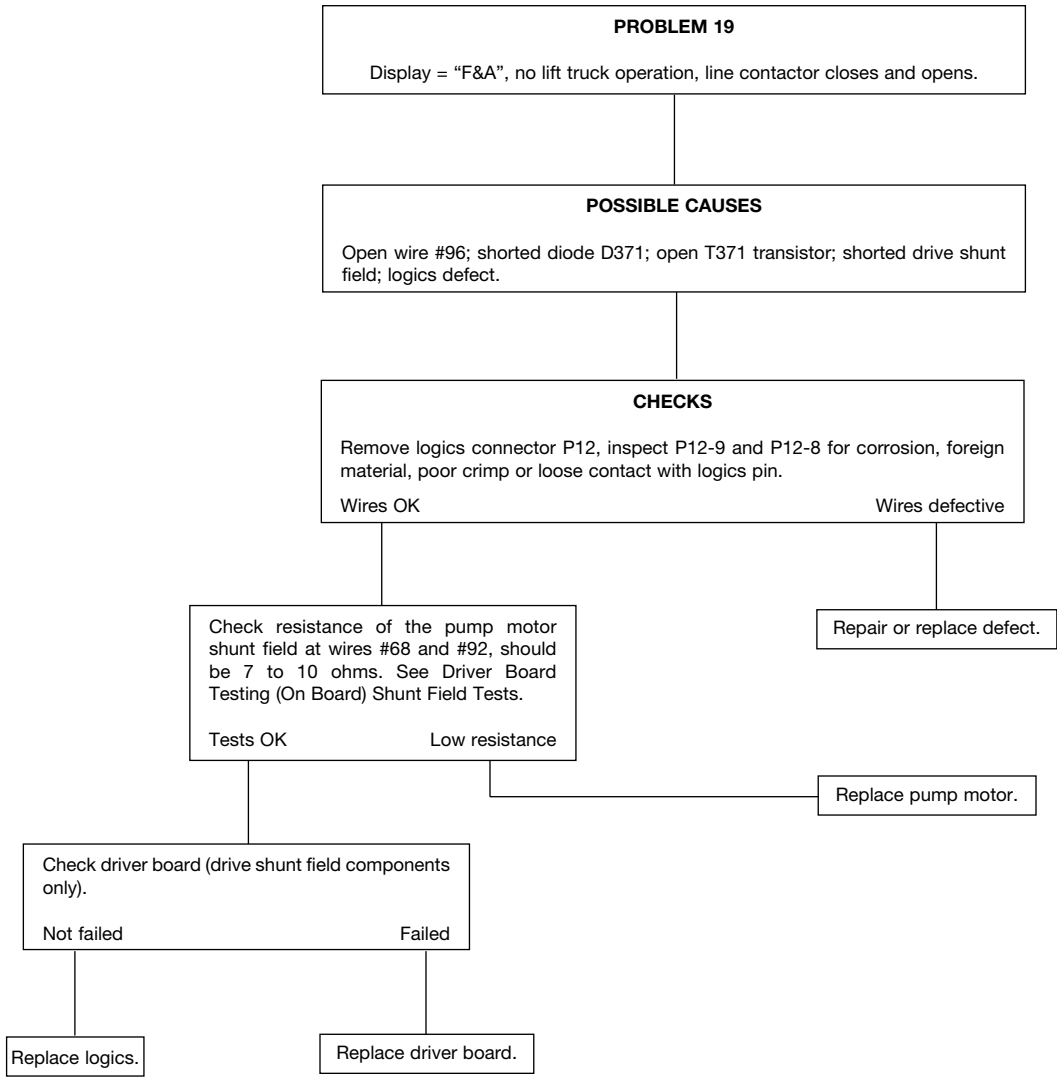

**PROBLEM 29**  
Lift sensor circuit defect.

**POSSIBLE CAUSES**  
Lift sensor not adjusted properly or defective; lift sensor wiring defect; valve control card (board) defect; logics defect.

**CHECKS**  
Disconnect the tilt and auxiliary switch connectors. Retest lift sensor circuit in self diagnostics.

Circuit passes self-diagnostics

Circuit fails self-diagnostics

Perform Problem 30 Tilt or Auxiliary Circuit defect.

Disconnect P13 connector at the valve control board. Connect multimeter negative lead to P13-5 and the positive lead to P13-2. Measure the voltage.

Battery voltage

0 Volts

Repair or replace broken wire between key switch and P13-2 (wire #4) or between P13-5 and battery negative (-).

Measure each voltage from P13-1, P13-3, P13-7 to battery negative P13-5.

All = 13 to 16V      Any/All = 0V

Reconnect P13 and adjust the lift sensor and valve control card to specifications.

Display does not change 0 to 7

Display changes 0 to 7

Perform self-diagnostics. Lift circuit should work.

Measure each voltage from P1-4, P1-5, P1-6 to battery negative.

All = 13 to 16V      Any/All = 0V

Repair or replace broken wire between P1 logics connector and P-13 connector.

Measure each voltage from P1-4, P1-5 and P1-6 to battery negative as the lever is pulled.

13 to 16V and .2V measured on each

13 to 16V and .2V **NOT** measured on each

Replace logics.

Replace valve control card.

Remove P1 logics connector. Check P1-4, P1-5, P1-6 for shorts to negative.

If shorted

No shorts

Repair or replace wire.

Replace logics.

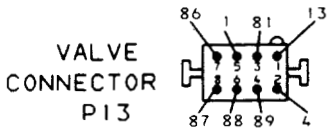

**NOTE:** Before lift truck is placed into service, connect tilt and auxiliary switches and verify proper adjustment.

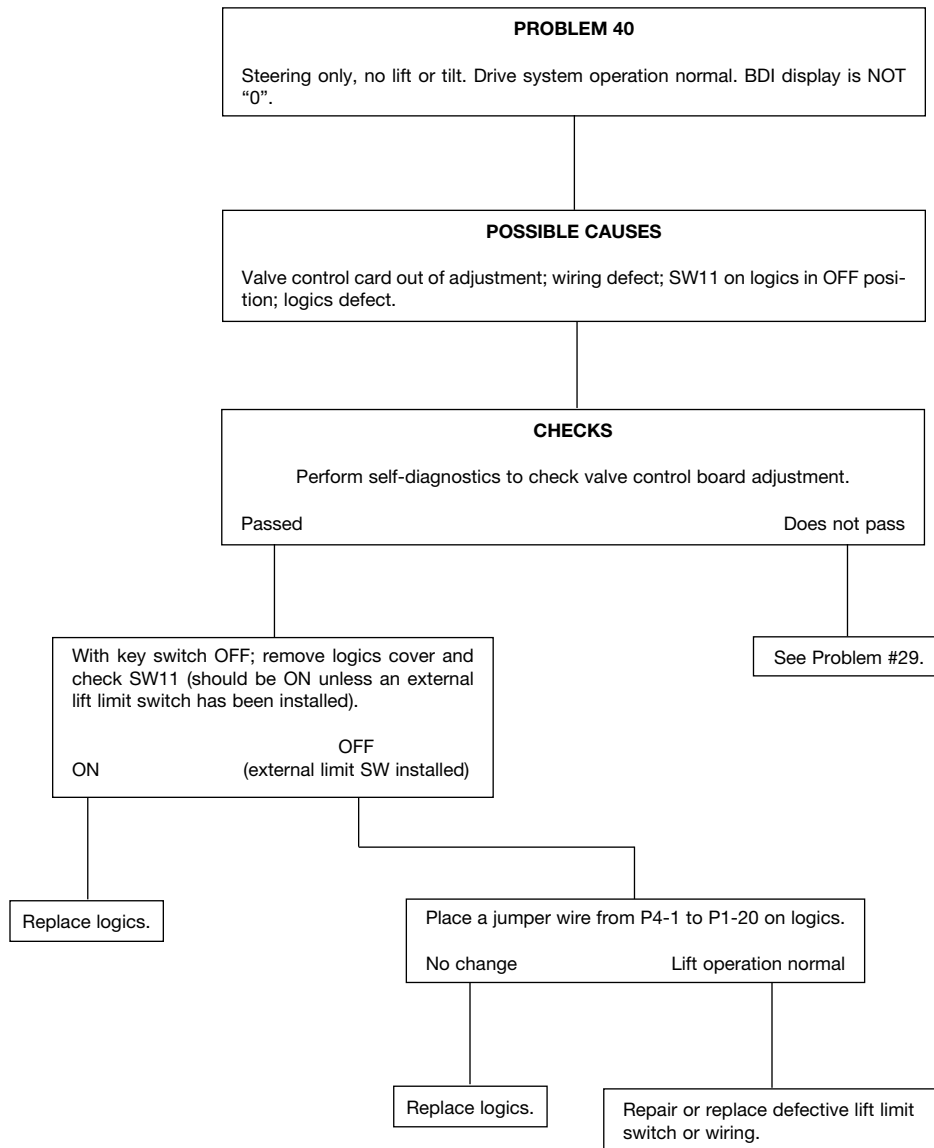

## Control Panel Overtemperature Protection

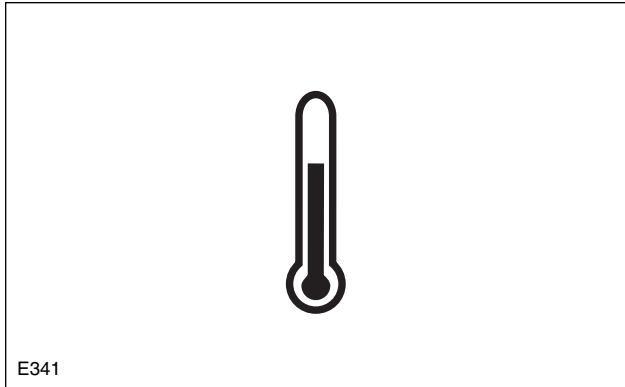

Overtemperature Indicator

Display = control panel overtemperature indicator symbol.

1. Connect the battery and discharge the head capacitor.
2. Disconnect the control panel thermal switch connector P8. Place the direction lever in neutral.
3. Connect the battery, close the seat switch and turn the key to ON. The overtemperature indicator symbol should appear on the instrument panel. If current limit is checked, it will be reduced.
4. Disconnect the battery and discharge the head capacitor. Connect P8 connector.

## Component Tests

### **⚠ WARNING**

**Battery voltage and high amperage are present. Injury to personnel is possible. Disconnect the battery and discharge the head capacitor before any contact is made with the control panel.**

To clean the control panel, use air pressure to blow off dust and dirt. **Do not use steam or solvent.**

## NOTICE

Do not use steam or solvent to clean the controls. Damage can be caused to the control panel. Use pressure from an air hose with a maximum pressure of 205 kPa (30 psi) to clean the control panel when necessary. The air supply must be equipped with a water filter.

**NOTE:** When control wires and power cables or bus bars are to be connected to the same bolt or stud, place all control wires together on the top of the bus bar or power cable.

Use the wiring diagram and electrical schematic (located inside rear panel cover) to locate components referred to by name and number in the procedures that follow. All wires must be located as shown on the wiring diagram and schematic.

## Vehicle Monitoring System Quick Reference Voltage Check

The chart that follows is a quick reference of the expected voltages at the logics card. These voltage patterns are used with the single digit display.

VOLTAGE AT CONNECTORS				
Number Displayed	P1-19	P1-18	P1-17	P1-16
0	0V	0V	0V	0V
1	0V	0V	0V	12V
2	0V	0V	12V	0V
3	0V	0V	12V	12V
4	0V	12V	0V	0V
5	0V	12V	0V	12V
6	0V	12V	12V	0V
7	0V	12V	12V	12V
8	12V	0V	0V	0V
9	12V	0V	0V	12V
A	12V	0V	12V	0V
B	12V	0V	12V	12V
Blank	12V	12V	0V	0V
D	12V	12V	0V	12V
E	12V	12V	12V	0V
F	12V	12V	12V	12V

## Hydraulic Pump Side Tests

1. Disconnect the battery, discharge the head capacitor and remove the logics cover.

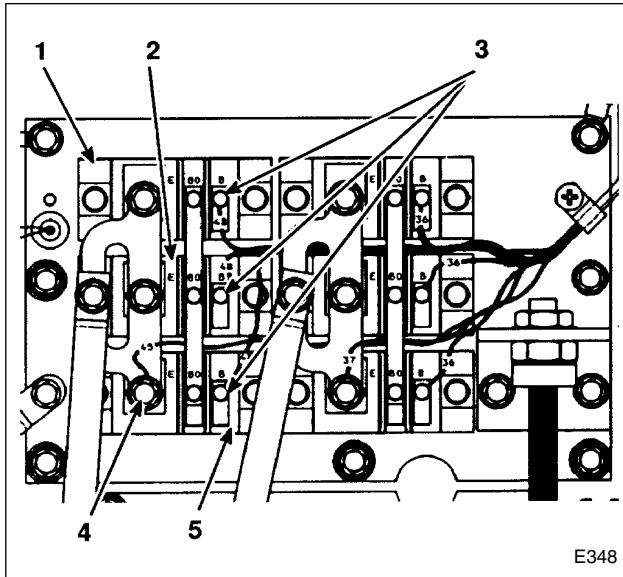

Location Of Components

(1) Transistor T1P. (2) Transistor T2P. (3) Base wires #48. (4) Emitter wire #45. (5) Transistor T3P.

2. Disconnect base wires #48 (3) from the base of T1P, T2P and T3P.
3. Disconnect wire #45 (4) from the emitter of T3P (5).

4. Resistor R323 and diode D321 test.

Set the multimeter to the 200 ohm range. Connect the positive lead to each base wire #48 (3) one at a time. Connect the negative lead to wire #45 (4). The measurement must be 6 to 9 ohms.

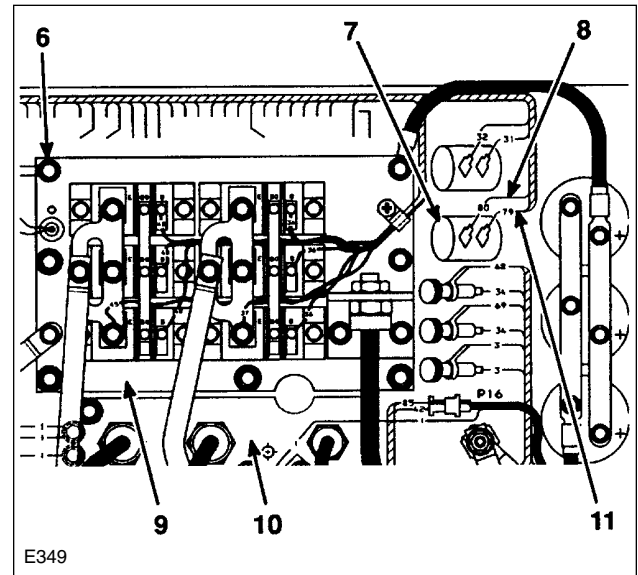

Location Of Components

(6) Wire #34 connection. (7) Resistor R322. (8) Wire #80. (9) Positive heatsink. (10) Negative heatsink. (11) Wire #79.

5. Disconnect wire #34 (6) that goes to the driver board from the positive heatsink (9).

6. Disconnect wire #80 (8) from R322 (7).

7. Transistor T324 and T325 (collector/emitter) and Z323 test.

Set the multimeter to the diode test position. Connect the positive lead to each wire #48 (3) one at a time. Connect the negative lead to wire #34 (6). The measurement must be .3 to .9 volts.

Reverse the test leads (positive lead to wire #34 and negative lead to each base wire #48). The measurement must be OL.

8. Transistor T324 and T325 (collector/base) test.

Set the multimeter to the diode test position. Connect the positive lead to each wire #48 (3) one at a time. Connect the negative lead to wire #80 (6). The measurement must be .3 to .9 volts.

Reverse the test leads (positive lead to wire #80 and negative lead to each base wire #48). The measurement must be OL.

9. Transistor T324 and T325 (emitter/base) and R321 test.

Set the multimeter to the 200 ohm range. Connect the positive lead to wire #34 (6). Connect the negative lead to wire #80 (8). The measurement must be 3 to 5 ohms.

## Lift Sensor

1. Disconnect the battery and discharge the head capacitor.

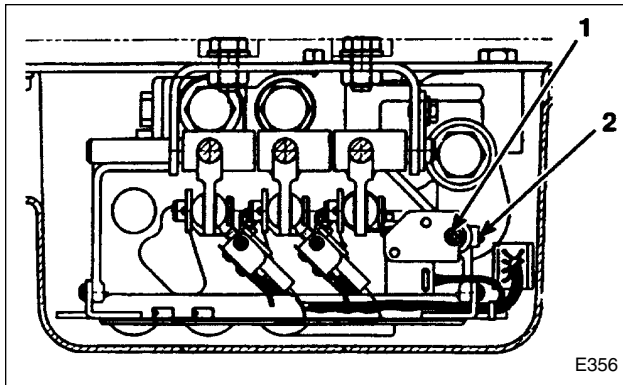

Location Of Components  
(1) Screw. (2) Setscrew.

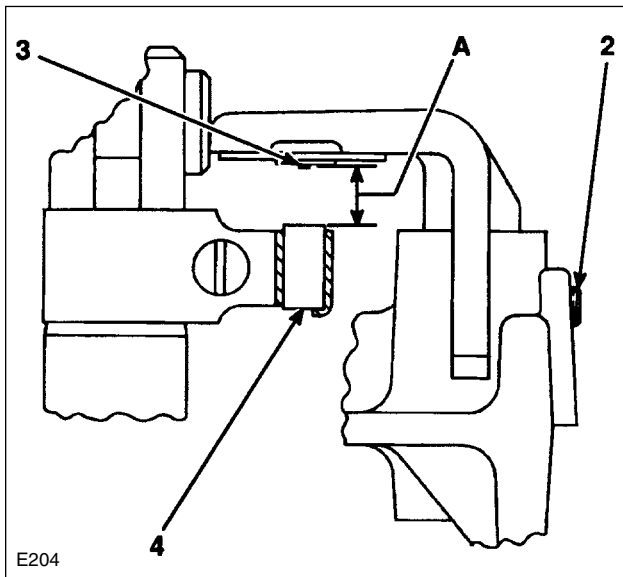

Lift Sensor Adjustment  
(2) Setscrew. (3) Lift sensor (transducer). (4) Magnet. (A) 2.0 mm (.078 in) clearance.

### NOTICE

Lift sensor may be damaged. Do not allow magnet (4) to make contact with the lift sensor (3) when the lift lever is activated.

2. Loosen setscrew (2).
3. Adjust screw (1) to make clearance (A) 2.0 mm (.078 in) between the lift sensor (3) and the magnet (4) when the lift lever is activated fully (pulled all the way back).

4. Tighten the setscrew (2). Place the lift truck in "Self" diagnostics and check the lift sensor circuit. The valve control card may need adjusting.

## Valve Control Card

### ⚠ WARNING

The lift truck can move suddenly. Battery voltage and high amperage are present. Injury to personnel is possible. Safely lift both drive wheels off the floor. Put blocks of wood under the frame so that the drive wheels are free to turn. During any test or operation check, keep away from drive wheels.

1. Verify that the lift sensor clearance is adjusted properly.
2. Disconnect all tilt and auxiliary switch connectors.
3. Place the lift truck in "Self" diagnostics so that the display is flashing the lift speed by bypassing Tests 1, 2 and 3 with the RUN/DIAG/SETUP switch. (See Built-In Diagnostic Operation in the Troubleshooting section for the correct procedure.)

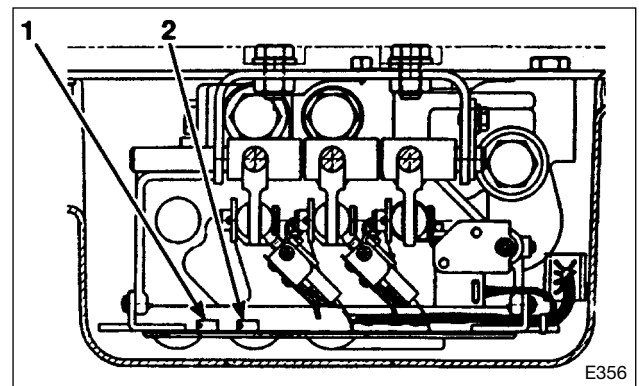

Top View Of Valve Control. Location Of Components  
(1) P1 potentiometer. (2) P2 potentiometer.

4. Turn potentiometer P1 (1) fully counterclockwise until a clicking sound is heard (roughly 20 turns).
5. Turn potentiometer P2 (2) fully counterclockwise until a clicking sound is heard (roughly 20 turns).
6. Turn potentiometer P2 (2) 15 turns clockwise.
7. The display should be flashing a "0". If not, adjust P2 (2) counterclockwise until a flashing "0" is obtained.

**SAFETY** **WARNING**

The proper and safe lubrication and maintenance for this lift truck, recommended by Cat lift trucks, are outlined in the **OPERATION & MAINTENANCE MANUAL** for these trucks.

**Improper performance of lubrication or maintenance procedures is dangerous and could result in injury or death. Read and understand the OPERATION & MAINTENANCE MANUAL before performing any lubrication or maintenance.**

The serviceman or mechanic may be unfamiliar with many of the systems on this truck. This makes it important to use caution when performing service work. A knowledge of the system and/or components is important before the removal or disassembly of any component.

Because of the size of some of the truck components, the serviceman or mechanic should check the weights noted in this manual. Use proper lifting procedures when removing any components.

Following is a list of basic precautions that should always be observed.

1. Read and understand all warning plates and decals on the truck before operating, lubricating or repairing the product.
2. Always wear protective glasses and protective shoes when working around trucks. In particular, wear protective glasses when pounding on any part of the truck or its attachments with a hammer or sledge. Use welders gloves, hood/goggles, apron and other protective clothing appropriate to the welding job being performed. Do not wear loose-fitting or torn clothing. Remove all rings from fingers when working on machinery.

 **WARNING**

**Do not operate this truck unless you have read and understand the instructions in the OPERATION & MAINTENANCE MANUAL. Improper truck operation is dangerous and could result in injury or death.**

3. Do not work on any truck that is supported only by lift jacks or a hoist. Always use jack stands to support the truck before performing any disassembly.
4. Lower the forks or other implements to the ground before performing any work on the truck. If this cannot be done, make sure the forks or other implements are blocked correctly to prevent them from dropping unexpectedly.
5. Use steps and grab handles (if applicable) when mounting or dismounting a truck. Clean any mud or debris from steps, walkways or work platforms before using. Always face truck when using steps, ladders and walkways. When it is not possible to use the designed access system, provide ladders, scaffolds, or work platforms to perform safe repair operations.
6. To avoid back injury, use a hoist when lifting components which weighs 23 kg (50 lb.) or more. Make sure all chains, hooks, slings, etc., are in good condition and are of the correct capacity. Be sure hooks are positioned correctly. Lifting eyes are not to be side loaded during a lifting operation.
7. To avoid burns, be alert for hot parts on trucks which have just been stopped and hot fluids in lines, tubes and compartments.

# TABLE OF CONTENTS

---

## CHAPTER 8 TROUBLESHOOTING

Differential and Final Drive . . . . .	8-1
Drive Motor . . . . .	8-2
Brake System . . . . .	8-9
Steering System . . . . .	8-11
Hydraulic System . . . . .	8-13

## CHAPTER 9 MASTING

<b>Specifications . . . . .</b>	<b>9-1</b>
Lift Cylinders . . . . .	9-2
Flow Regulator Valve . . . . .	9-6
Down Safety Valve . . . . .	9-7
<b>Removal and Installation</b>	
Lift Cylinders - (Dual-Stage Panoramic Mast) (Simplex Mast) . . . . .	9-8
Lift Cylinders - (Triple-stage Full Free Panoramic Mast) (Duplex and Triplex Mast) . . . . .	9-11
Tilt Cylinders . . . . .	9-14
<b>Disassembly (No. 1)</b>	
Lift Cylinders (Simplex Mast) . . . . .	9-15
<b>Disassembly (No. 2)</b>	
Lift Cylinders . . . . .	9-16
Inspection after Disassembly . . . . .	9-17
Reassembly . . . . .	9-17
<b>Disassembly (No. 3)</b>	
First Lift Cylinders (Duplex Mast, Triplex Mast) . . . . .	9-19
Key Points for Disassembly . . . . .	9-19
<b>Disassembly (No. 4)</b>	
Key Points for Disassembly . . . . .	9-20
Inspection after Disassembly . . . . .	9-21
<b>Reassembly</b>	
First Lift Cylinders (H40A, J40A, thru J55A) . . . . .	9-21
Second Lift Cylinders . . . . .	9-22
Key Points for Reassembly . . . . .	9-23
<b>Disassembly (No. 6)</b>	
Second Lift Cylinders - Triplex Mast . . . . .	9-24

# ELECTRICAL AND ELECTRONIC

---

<b>Contactors (Regenerative, Bypass, Line and Lift)</b> .....	<b>2-12</b>
Disassemble and Assemble Contactors (Regenerative, Bypass, Line and Lift) .....	2-12
<b>Line Fuse</b> .....	<b>2-13</b>
Remove & Install Line Fuse .....	2-13
<b>Contactors (Forward and Reverse)</b> .....	<b>2-14</b>
Remove & Install Contactors (Forward & Reverse).....	2-14
<b>Disassemble &amp; Assemble Contactors (Forward and Reverse)</b> .....	<b>2-15</b>
<b>Current Sensor</b> .....	<b>2-16</b>
Remove & Install Current Sensor .....	2-16
<b>Fuses</b> .....	<b>2-16</b>
Remove & Install Fuses 1628 – 010.....	2-16
<b>System Check With Static Diagnostics</b> .....	<b>2-17</b>
<b>Run Time Diagnostics</b> .....	<b>2-17</b>
<b>MicroCommand Control System Wiring Connections</b> .....	<b>2-18</b>
<b>Electrical Schematics</b> .....	<b>2-19</b>

## ELECTRICAL AND ELECTRONIC

### Line Contactor

#### Remove & Install Line Contactor

**WARNING**

**Battery Voltage and high amperage are present. Injury to personnel is possible. Disconnect the battery and discharge the capacitors before any contact is made with the control panel.**

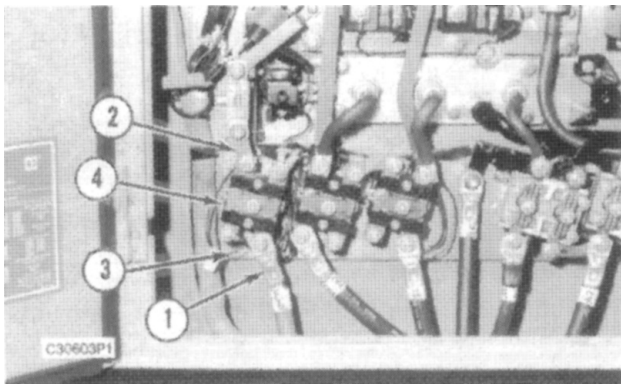

1. Identify and disconnect electrical cables (1).
2. Disconnect bus bars (2) and electrical wiring (3).
3. Remove nut and then remove line contactor (4).

**NOTE**

**The following steps are for the installation of the contactor.**

4. Install the line contactor (4) in position with the nuts.
5. Reconnect the electrical wiring (3) and bus bars (2).

**NOTE**

**Use a backup wrench when tightening the electrical cables to the contactors and**

6. Connect electrical cables (1) and their fasteners. Tighten the fasteners (1/4 inch and 5/16 inch) to a torque of **7 to 9 N•m (62 to 80 lb ft) and 12 to 18 N•m (107 to 160 lb in).**

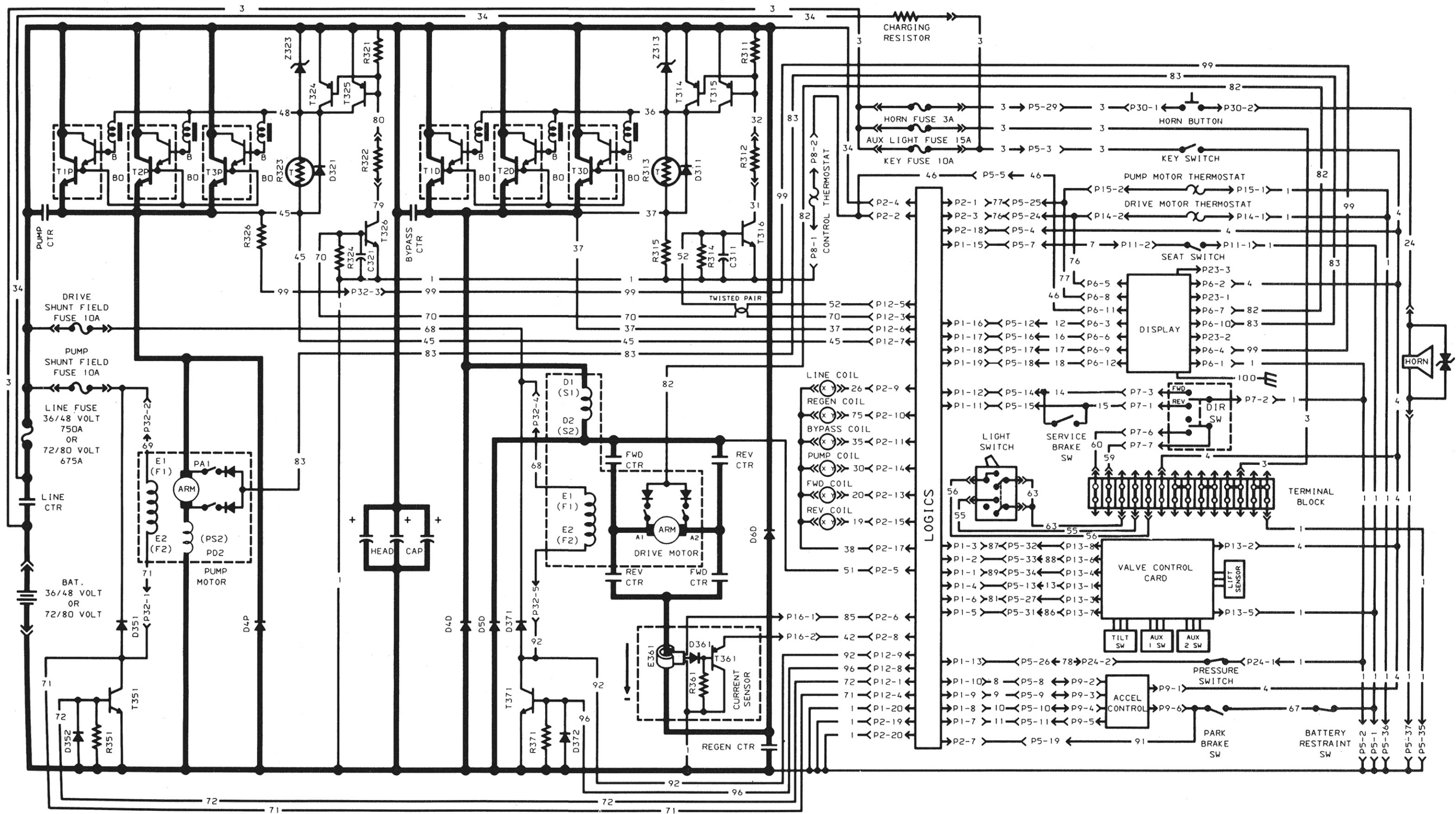

## DIFFERENTIAL AND FINAL DRIVE



12. Remove the bearing cones from the differential with the puller assembly tool (D). Keep the shims with their bearings.



16. Remove the pinion shaft with a soft hammer. Use care, so the shaft will not fall on the floor. Keep any shims that come out with the shaft.

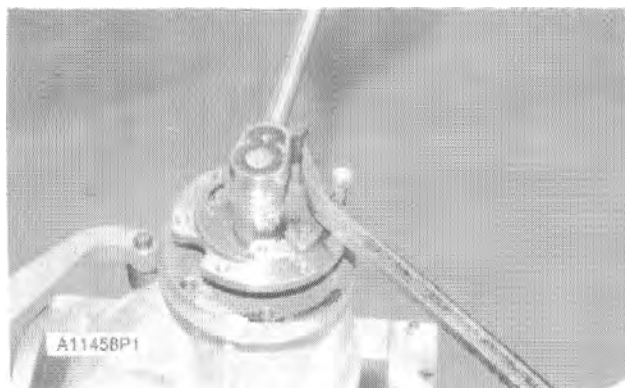

13. Install two 3/8-16 x 2" NC bolts into the flange.

14. Use a wrench and a bar to remove the flange nut.

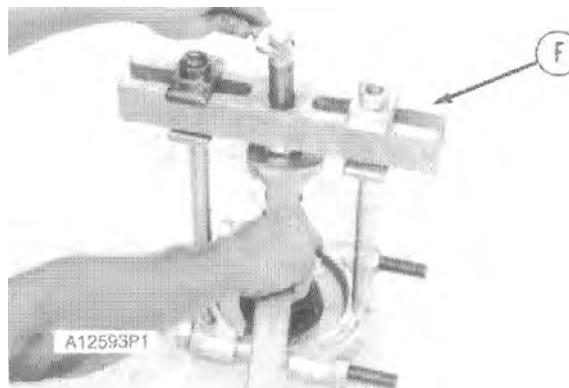

17. Remove the bearing cone from the pinion shaft with a bearing puller (F).

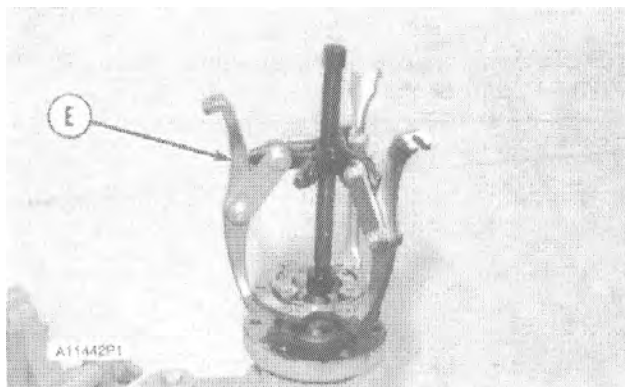

15. Remove the flange with a puller assembly (E).

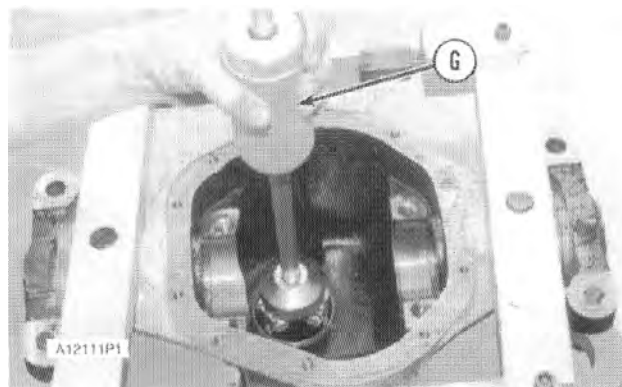

18. Remove the pinion bearing cup from the housing with a slide hammer puller (G). Keep any shims that are found.

## DIFFERENTIAL AND FINAL DRIVE

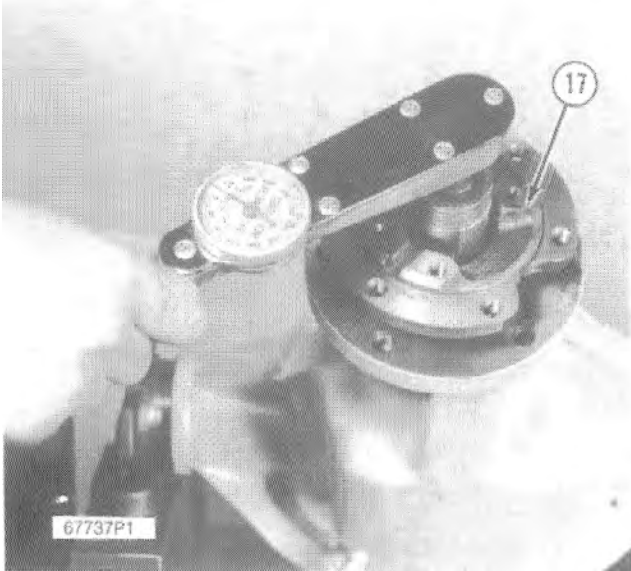

19. Put SAE 90 oil on the outer pinion bearing cone. Install the outer bearing cone and end flange (17).
20. Install the pinion nut tighten it until a torque of **1.7 Nm (15 lb in)** is needed to turn the pinion.

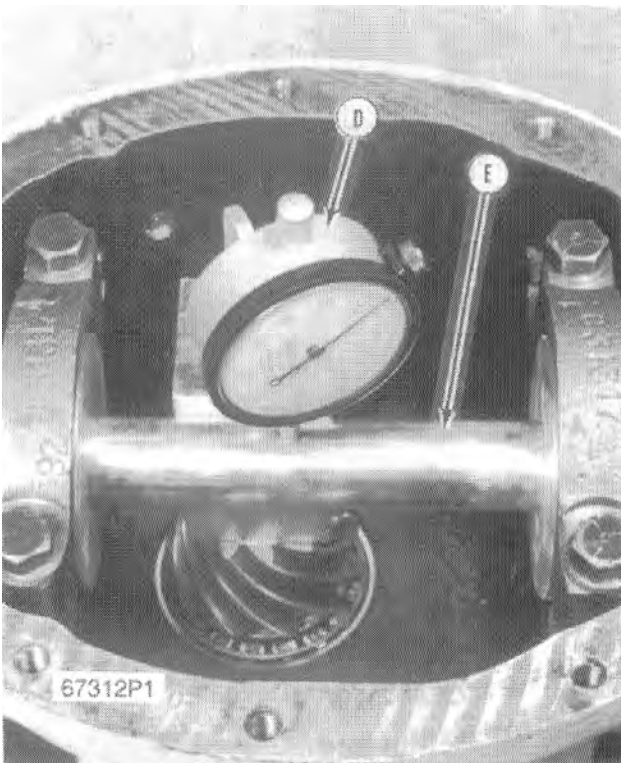

21. Install assembly gauge (E). Install the bearing caps with the marks in alignment and

tighten the bolts just enough to hold the bar away from the assembly gauge. Put the dial indicator (D) in position on the block which is part of the assembly gauge (E). Adjust the dial indicator to zero on the surface of the block. Move the dial indicator to the surface of the bar. The difference between the two indications must be within **0.000 to 0.051 mm (.000 to .002 in)** of the numbers on the pinion.

22. If the indications in step 21 are not correct, remove the pinion and the pinion bearing inner cup. Add or subtract shims until the indication is correct.



23. Remove the end flange and the outer bearing cone. Put the shims that were removed from the pinion shaft, during disassembly, in position on the pinion shaft.
24. Install the outer bearing cone and the end flange.

### NOTE

**Do not install the seal at this time.**

CLICK HERE TO **DOWNLOAD** THE COMPLETE MANUAL

- Thank you very much for reading the preview of the manual.
- You can download the complete manual from: [www.heydownloads.com](http://www.heydownloads.com) by clicking the link below



- Please note: If there is no response to CLICKING the link, please download this PDF first and then click on it.

CLICK HERE TO **DOWNLOAD** THE COMPLETE MANUAL

# DIFFERENTIAL AND FINAL DRIVE

## Drive Axle Shaft

### Remove Drive Axle Shaft

START BY:

- a. remove final drive

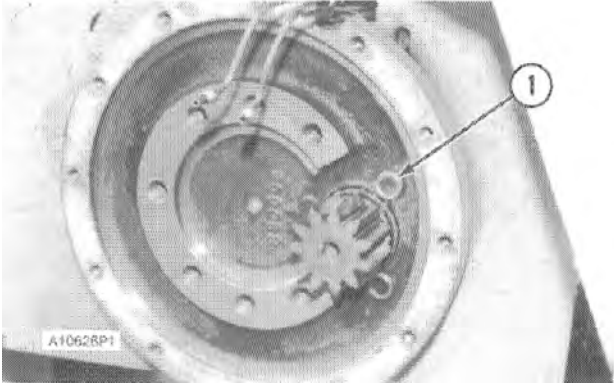

1. Remove two retainers (1).

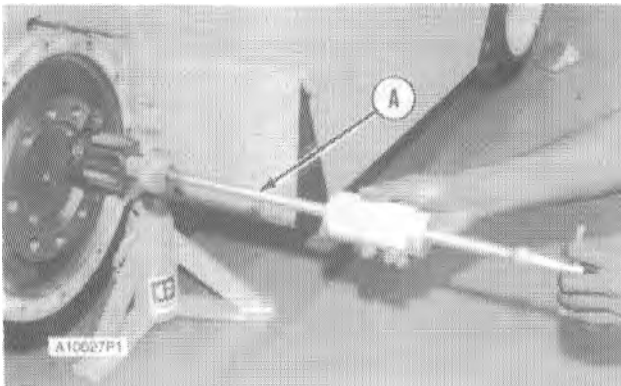

2. Remove axle shaft with slide hammer puller (A).

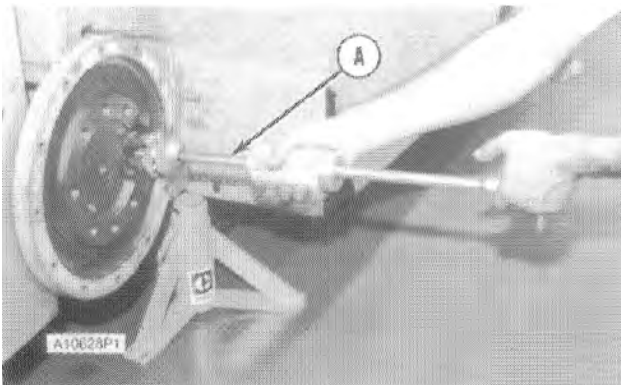

3. Remove axle shaft seal with slide hammer puller (A).

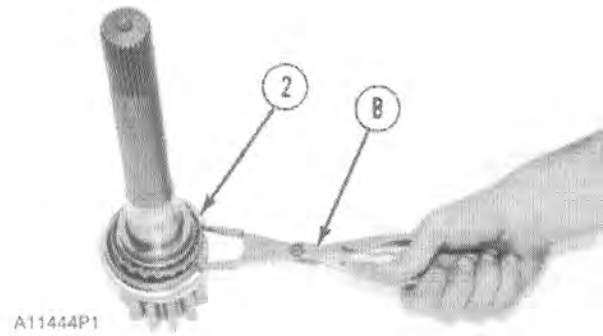

4. Remove retaining ring (2) with tool (b).

#### NOTE

Replace retaining ring with a new retaining ring when reassembling.

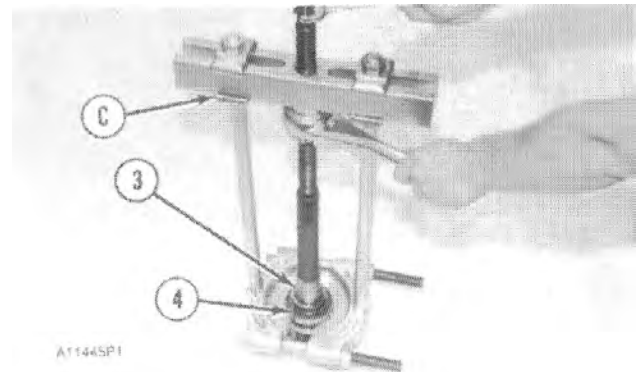

5. Remove retainer (3), bearing cone and cup (4) with tooling.

#### NOTE

Replace retainer with a new retainer when reassembling.

6. Remove the other bearing cup and cone with tooling.

# DRIVE MOTOR

## New Brush Installation

### NOTE

**Installation of new brushes is a two person operation.**

1. Disconnect the batteries and remove them from the lift truck. Put the batteries close enough to the truck, so the battery connector can be plugged in.
2. Lift the truck and put jacks under it, so that the drive wheels are off the ground. Put blocks in front and back of the steering wheels.
3. Discharge the head capacitors. These trucks have three head capacitors.
4. Remove the old commutator screen cover. Remove the old brushes.

### NOTE

**Installation of the wrong brushes can cause early motor failure. Always make sure the correct brushes are installed.**

5. Install new brushes (1). Make sure the brushes move freely in the brush holders. Use sandpaper to remove brush material if there is a restriction of brush movement.
6. Install brush springs (2) and make sure they fasten into the brush holder box.
7. Use a screwdriver to lift the spring into a good position on the top of the brush.
8. Pull up on the two wires of each brush until the contact end of the brush moves away from the commutator. Release the wires to see if the brush moves smoothly back into contact with the commutator. If it is too diffi-

cult to pull out, or it does not move smoothly in the brush holder box, remove the spring and brush. Make an inspection to find and correct the cause of the problem.

9. Connect the batteries to the battery connector.



### WARNING

**Wear eye protection when seating, polishing or cleaning the motor with air pressure. During the seating and polishing procedure, keep fingers away from components in rotation. For prevention of injury to fingers, do not use a commutator cleaner or seater stone that is shorter than 63.5 mm (2.50 in).**

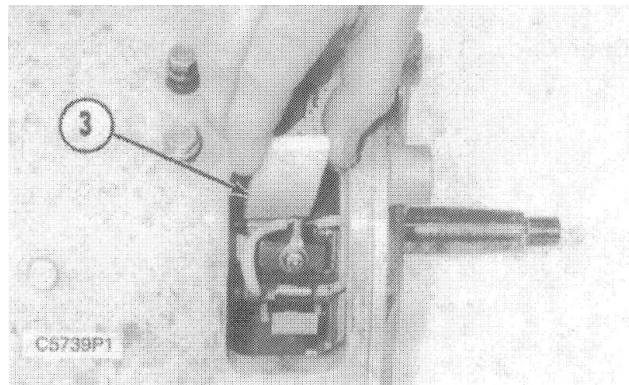

**Brush Seating (Typical Example)**  
(3) 6V2063 Brush seater stone.

10. Place 6V2063 Brush Seater Stone (3) on the commutator and operate the motor at a slow speed.

### NOTE

**Do not let stone (3) stay in contact with the commutator bar too long of a time; this causes more wear than is necessary to the brushes and the commutator.**

## DRIVE MOTOR

---

6. The smh estimate of brush life can be used if the machine is to work at the same rate (duty cycle), the battery is not discharged too much or the battery cells have not become damaged. If the machine is made to work harder, the battery is discharged too much, or the battery cells become damaged, the motor temperature will get hot very fast. This will cause rapid wear of the brushes.
  
7. It is important to check brush length and brush condition at a specific time, such as during the preventative maintenance check. If an inspection shows that brush life will not extend to the next preventative maintenance check, install new brushes.

# BRAKE SYSTEM

## Foot Operated Parking Brake

### Description

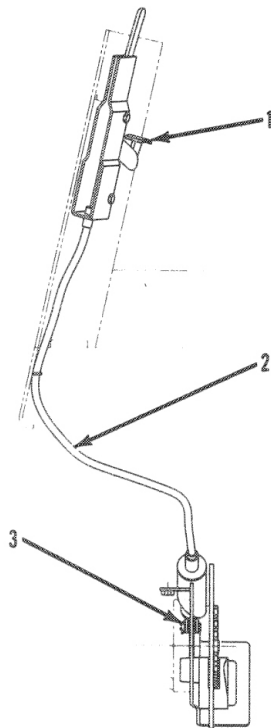

C37547P1

#### Parking Brake Control Group

(1) Foot pedal. (2) Cable assembly. (3) Clevis.

The disc type parking brake is installed on the rear of the differential. The parking brake control is mounted on the cowl and is connected to the brake assembly with cable assembly (2). The parking brake is activated when foot pedal (1) is pushed down. An electrical switch in the control assembly will not allow the drive motor to operate when the parking brake is activated. The parking brake is released when the release lever is moved upward.

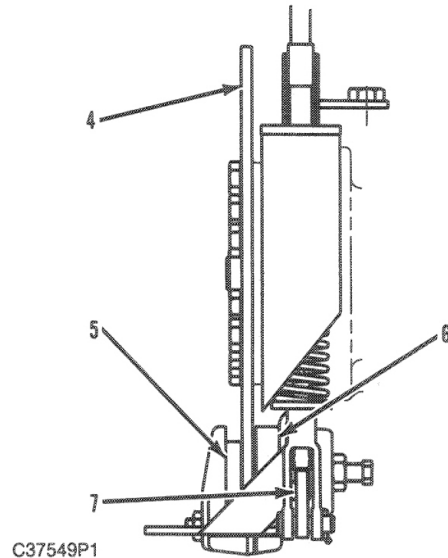

C37549P1

#### Parking Brake

(4) Disc. (5) Pucks. (6) Caliper assembly. (7) Lever.

When the parking brake is engaged, cable assembly (2) pushes clevis (3) and lever (7) down. This action allows pucks (5) in caliper assembly (6) to contact disc (4). This stops any lift truck movement. When the parking brake is released, the process is reversed and pucks (5) move away from disc (4).



# STEERING SYSTEM

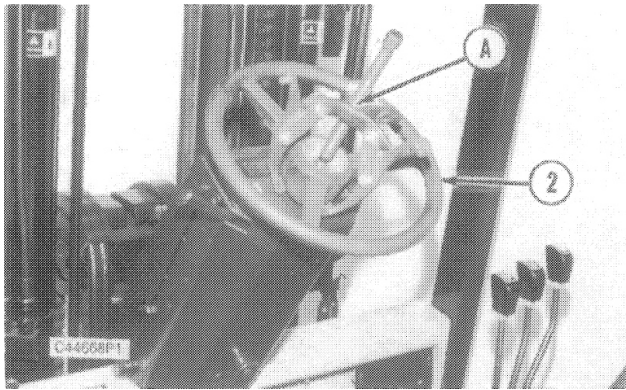

3. Remove steering wheel (2) with puller.

## NOTE

The following steps are for installation of the steering wheel.

4. Put the steering wheel in position on the shaft. Install cup (4) and nut (3). Tighten the nut to a torque of  **$40 \pm 5 \text{ N}\cdot\text{m}$  ( $30 \pm 4 \text{ lb ft}$ )**.
5. Install the cup on the steering wheel.

## Steer Axle and Wheel

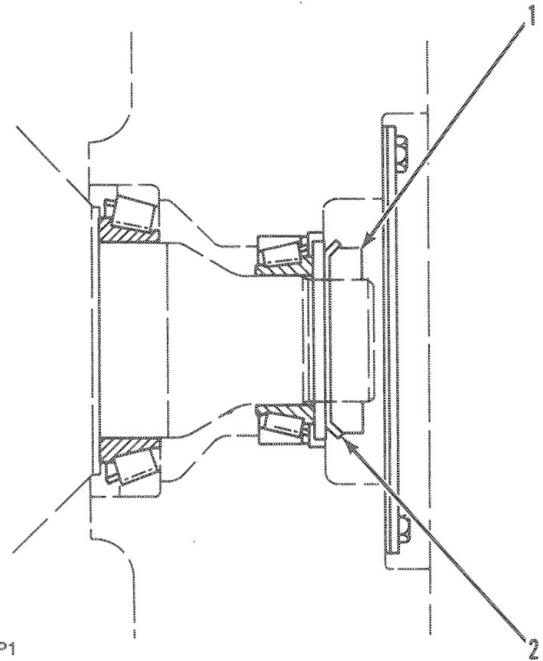

1. Do the steps that follow for steer bearing adjustment:
  - a. Tighten nut (1) slowly to  **$270 \text{ N}\cdot\text{m}$  ( $200 \text{ lb ft}$ )** while turning the wheel.
  - b. Loosen nut (1) completely. Tighten it again to a torque of..... **$50 \pm 5 \text{ N}\cdot\text{m}$  ( $37 \pm 4 \text{ lb ft}$ )**
2. Bend lock (2) over nut (1).

## HYDRAULIC SYSTEM

---

Excess flow protectors (2) and (4) will act as a lowering flow control valve if an oil line between them and lowering flow control valve (7) is broken when the mast is raised or lowered. This prevents a sudden fall of the mast or carriage if an oil line is broken.

The tilt forward, tilt back and sideshifter speeds are controlled by the flow control valves in hydraulic control valve (6). There is an anti-cavitation valve inside the tilt spool to prevent cavitation (development of air pockets) in tilt cylinders (8).

Refer to Lift Truck Hydraulic System Schematic for M70D, M80D, M100D and M120D at the end of this section.

# HYDRAULIC SYSTEM

## Hydraulic Control Valve

### Neutral Position

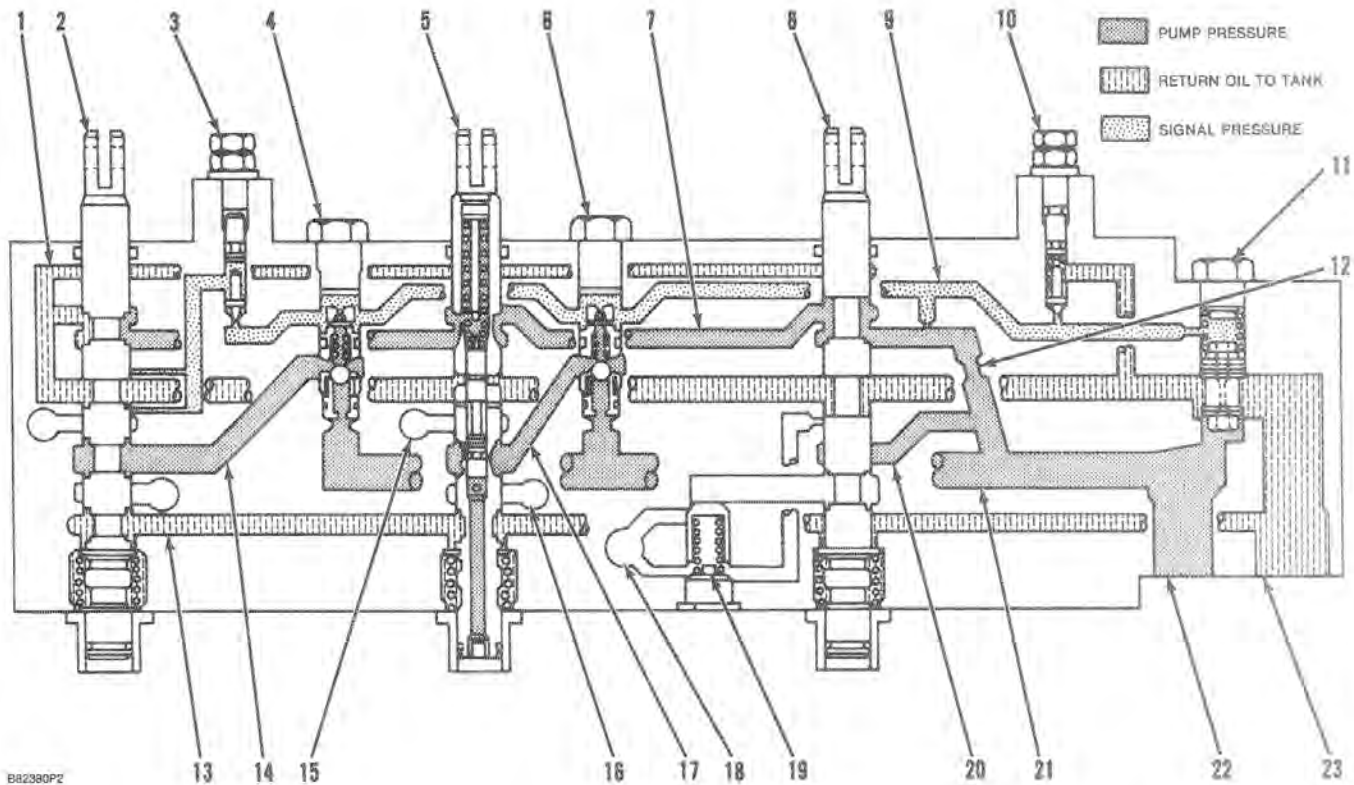

**Hydraulic Control Valve in Neutral Position**

- (1) Passage. (2) Sideshift spool. (3) Relief valve (sideshift). (4) Flow control valve (sideshift). (5) Tilt spool. (6) Flow control valve (tilt). (7) Bypass passage. (8) Lift spool. (9) Pressure sensing passage. (10) Relief valve (lift and tilt). (11) Flow control valve. (12) Orifice. (13) Passage. (14) Passage. (15) Passage (to rod end of tilt cylinders). (16) Passage (to head end of tilt cylinders). (17) Passage. (18) Passage to lift cylinder. (19) Check valve. (20) Passage. (21) Passage. (22) Inlet. (23) Outlet.

Springs in the control valve keep spools (2), (5) and (8) and the control levers in the neutral position. Pump oil will flow through inlet (22) to passage (21) and lift spool (8).

Oil then goes through orifice (12) to bypass passage (7) and pressure sensing passage (9). Orifice (12) will pass approximately 1/3 of the oil in passage (21) to passage (7). Oil will flow through passage (7) to sideshift spool (2). The oil then goes through passage (1), outlet (23) and back to the hydraulic tank.

In NEUTRAL position, spools (2), (5) and (8) block passages (14), (17) and (20). The oil cannot go to the lift cylinder, tilt cylinders or sideshift cylinder. This creates a pressure build up in passage (21) which in turn produces a pressure drop at the outlet of orifice (12). The pressure drop is also felt in pressure sensing passage (9) and spring chamber (24) of flow control valve (11). This allows the pressures oil in passage (21) to be greater than the force of the spring (25). Flow control valve (11) moves up. Approximately 2/3 of the oil in inlet flow in passage (21) will now flow by valve (11) through outlet (23) and back to the hydraulic tank. As the pressure decreases in passage (21), the pressure difference across orifice

# HYDRAULIC SYSTEM

---

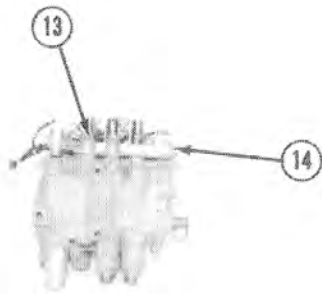

C44839P1

19. Install switch holding bracket (14) with two bolts (13).

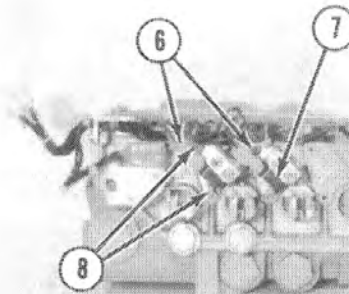

C44842P1

22. Install switches (7) and bracket with two bolts (8).

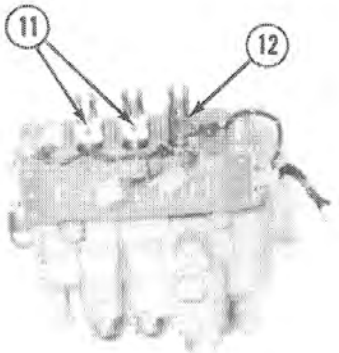

C44640P1

20. Install bracket (12) and bolt. Install two switch stops (11).

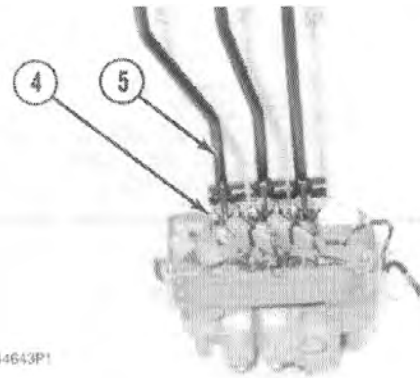

C44643P1

23. Install lever (5). Install clevis pin (4), washer and cotter pin. Repeat this step for the remaining levers.

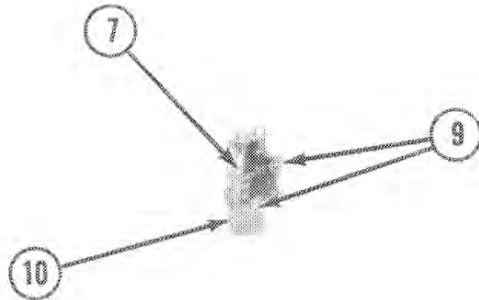

C44641P1

21. Install switch (7) from bracket (10). Install two retainers (9).

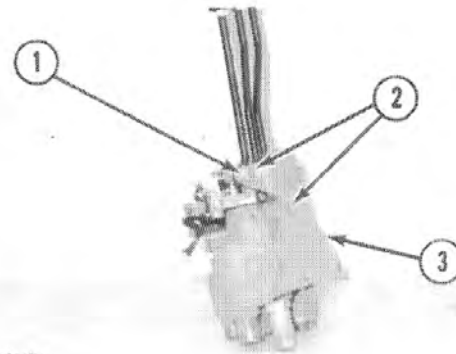

C44644P1

24. Install plate (3), rod (2) and bolts (1).

END BY:

- a. install hydraulic control valves.

# HYDRAULIC SYSTEM

## Shunt Field Tests

### Open Circuit Test

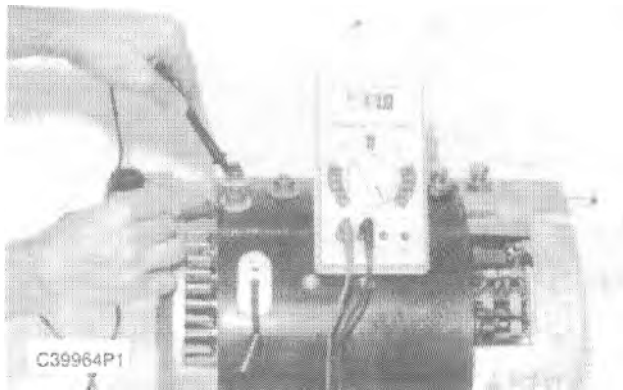

**Shunt Coil Open Circuit Test**

1. Switch the Function/Switch of the digital multimeter on the 200 ohm resistance ( $\Omega$ ) scale.
2. Put the test leads between the shunt terminals.
3. The resistance must be approximately 5 to 10 ohms. If the resistance is more than this, it is an indication of corrosion on the terminals or an open shunt coil.

### Ground Test

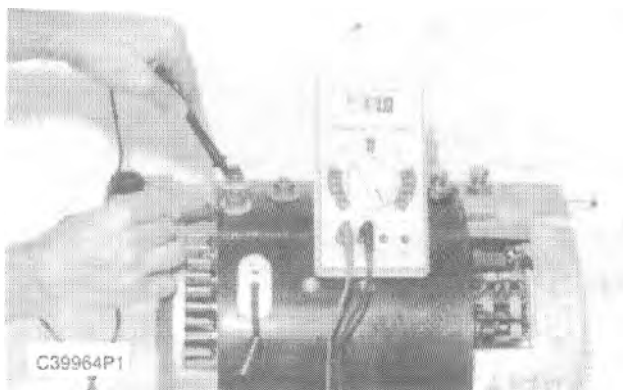

**Shunt Coil Ground Test**

1. Switch the Function/Range Switch of the digital multimeter to the 20M resistance ( $\Omega$ ) scale.

2. Put one test lead to either shunt coil terminal. Put the other test lead to the motor housing, there must be more than one mega ohm resistance. Check both shunt coil terminals.
3. If the indication is less than one mega ohm, the shunt coil is grounded and must be replaced.

### Brush Holder Test

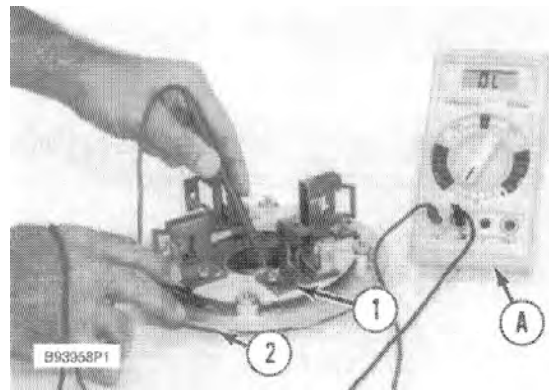

**Brush Holder Test (Typical Example)**  
(1) Brush holder. (2) End bell. (A) Multimeter.

1. The brush holders are mounted on an insulator at the commutator end of the motor. Make a visual inspection of the brush holders and insulator.
2. Switch the digital multimeter (A) Function/Range Switch to the 20M resistance ( $\Omega$ ) scale. Put one test lead to brush holder (1) and the other test lead to the end bell (2). The meter must show overload (OL).
3. Check each brush holder. If meter reading is low, the brush holder is grounded. Replace the insulator.

# TROUBLESHOOTING

---

## Drive Motor

### PROBLEM 1: Drive Motor Will Not Operate

#### PROBABLE CAUSE:

1. Switch not closed (battery connector, key switch, seat switch, direction switch or parking brake switch):

Close the switch. If it does not operate, test for power to the control panel and power flow through each switch with a voltmeter.

2. Bad connection. Fuse bad:

- Check battery connections.
- Check connections at battery connector.
- Check fuses, drive and logics.
- Replace fuse if bad.
- Check the drive motor and control panel for possible reasons for a bad fuse.

Some causes are:

- Operating with too heavy a transistor load – high current limit (C/L)
- Operating in stall conditions.
- Possible short circuit in drive motor, see Probable Causes 5,6 and 7.

3. Low Battery Voltage:

- Check battery terminal voltage. If too low, charge the battery.
- Check all of the cells for one or more that have defects.
- Check the specific gravity of each cell. The maximum density difference from the highest to the lowest cell must not be more than .020 SG (specific gravity).

4. Control panel operation not correct:  
See MicroCommand Control System Module, Service Manual SENB8464-03

5. Brushes are worn:

- Inspect the drive motor armature for burnt marks or scoring (scratches).
- Make corrections or make repair of the armature commutator and replace the brushes as necessary.
- Reference Problem 4: Sparks at the commutator and/or rapid brush wear.

6. Check for opens in the field coils:

- Test coils according to procedures in Field Coil and Terminal Test.

If there are opens, replace the field assembly.

7. Check for a short circuit in the armature windings:

- If the field winding poles are loose, make the necessary corrections.
- If the field armature bar insulation is defective, repair or rebuild the insulation or replace the armature.

8. Static return to off circuit actuated:

- If the static return to off circuit is actuated, the control will not start again until the accelerator is released and the directional control lever is returned to neutral.

# TROUBLESHOOTING

---

## Visual Checks

A visual inspection of the hydraulic system and its components is the first step when a diagnosis of a problem is made. Lower the carriage to the floor and follow these instructions:

1. Measure the oil level. Look for the air bubbles in the oil tank.
2. Remove the filter element and look for particles removed from the oil by the filter element. A magnet will separate ferrous particles from nonferrous particles (piston rings, O-rings seals, etc.).
3. Check all oil lines and connections for damage or leaks.
4. Check all the lift chains and the mast and carriage welds for wear or damage.

## Operation Checks

The operation checks can be used to find leakage in the system. They can also be used to find a bad valve or pump. The speed of rod movement when the cylinders move can be used to check the condition of the cylinders and the pump.

Lift lower, tilt forward, tilt back the forks several times.

1. Watch the cylinders as they are extended and retracted. Movement must be slow and regular.
2. Listen for noise from the pump.
3. Listen for the sound of the relief valve. It must not open except when the cylinders are fully extended or retracted, when the forks are empty.

## Hydraulic Oil Temperature

When the temperature of the hydraulic oil gets over 98.8° (210°F), polyurethane seals in the system start to fail. High oil temperature causes seal failure to become more rapid. There are many reasons why the temperature of the oil will get this hot.

1. Hydraulic pump is badly worn.
2. Heavy hydraulic loads that cause the relief valve to open.
3. The setting on the relief valve is too low.
4. Too many restrictions in the system.
5. Hydraulic oil level in the tank is too low.
6. High pressure oil leak in one or more circuits.
7. Very dirty oil.
8. Air in the hydraulic oil.

### NOTE

**If the problem is because of air in the oil, it must be corrected before the system will operate at normal temperature. There are two things that cause air in the oil (aeration).**

These are:

- Return oil to the tank goes in above the level of the oil in the tank.
- Air leaks in the oil suction line between the pump and the tank.

# MASTING

## Duplex Mast Second Lift Cylinders (H40A)

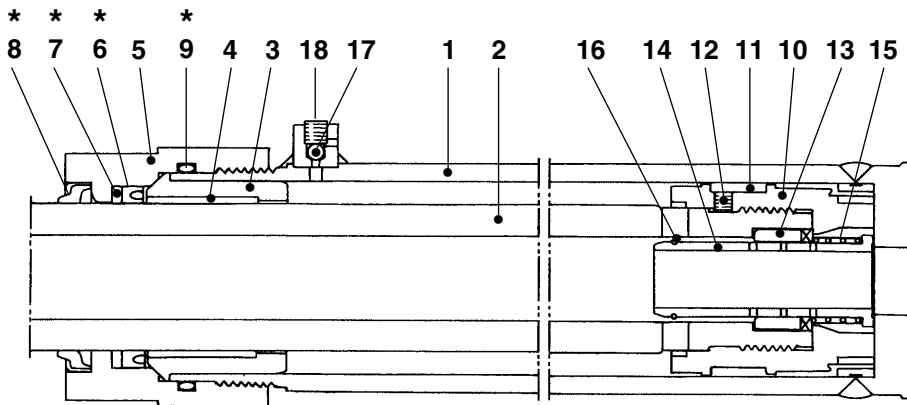

Parts marked with \* are included in the seal kit.

206949

- |                 |               |                  |
|-----------------|---------------|------------------|
| 1 Cylinder tube | 7 Backup ring | 13 Check valve   |
| 2 Piston rod    | 8 Wiper ring  | 14 Cushion spool |
| 3 Cylinder head | 9 O-ring      | 15 Spring        |
| 4 Bushing       | 10 Piston     | 16 Snap ring     |
| 5 Holder        | 11 Slide ring | 17 Steel ball    |
| 6 U-ring        | 12 Set screw  | 18 Set screw     |

## Triplex Mast Second Lift Cylinders (J40A)

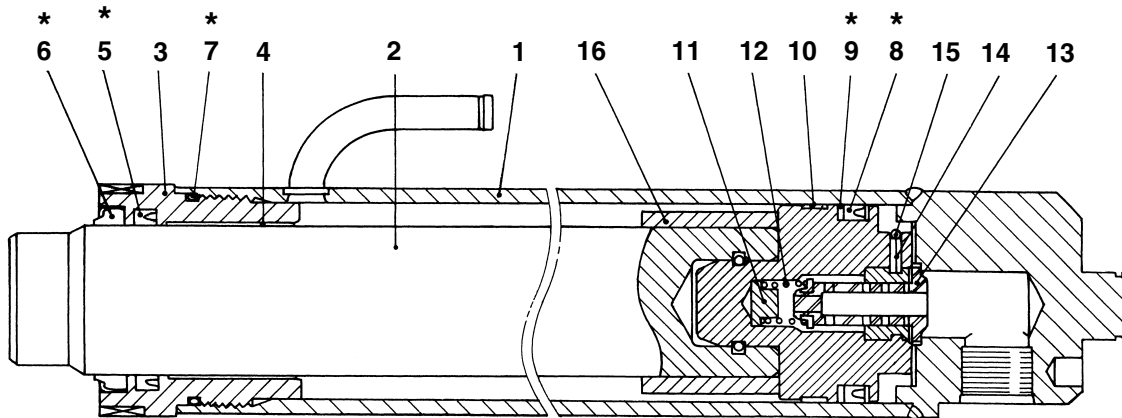

Parts marked with \* are included in the seal kit.

207778A

- |                 |                 |                  |
|-----------------|-----------------|------------------|
| 1 Cylinder tube | 7 O-ring        | 13 Cushion spool |
| 2 Piston rod    | 8 U-ring        | 14 Pin           |
| 3 Cylinder head | 9 Backup ring   | 15 Snap ring     |
| 4 Bushing       | 10 Bushing      | 16 Spacer        |
| 5 U-ring        | 11 Spring guide |                  |
| 6 Wiper ring    | 12 Spring       |                  |

# MASTING

## Tilt Cylinders

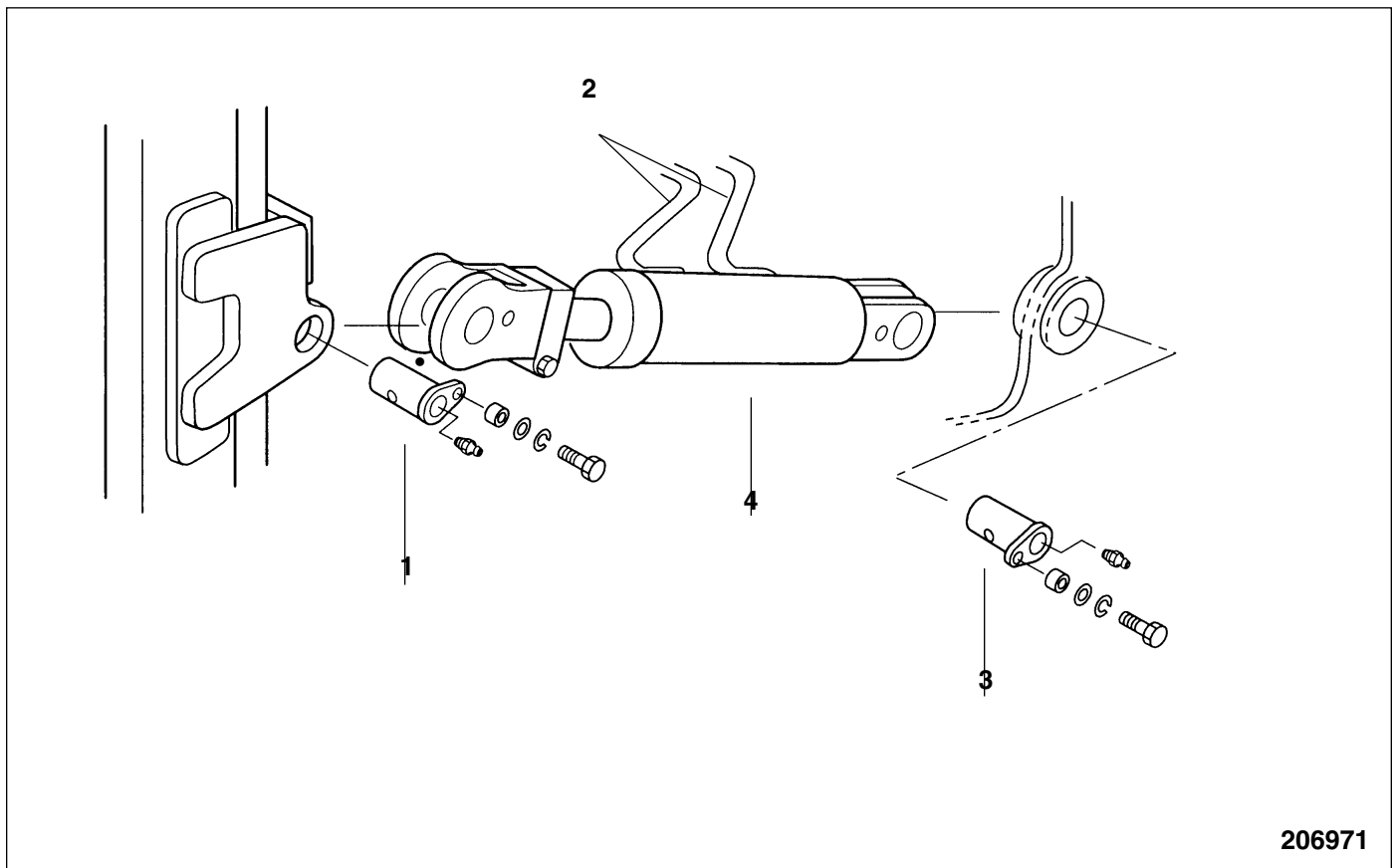

206971

- 1 Tilt cylinder pin
- 2 Hoses

- 3 Tilt cylinder pin
- 4 Tilt cylinder

### Start by:

- (1) Lower the forks to the bottom, and tilt the mast fully forward.
- (2) Hitch a sling to the top crossmember of outer mast, and support the weight of the mast with a hoist.

### Suggestions

#### 1. Retracting piston rod

Remove tilt cylinder pin 1. Start the engine and retract the piston rod to the full stroke, then stop the engine.

#### 2. Disconnecting hoses

Disconnect hoses 2 from the cylinder at the connectors. Use a container to catch oil from flowing out of the cylinder. Attach caps to the connectors of the cylinder to protect the threads of the connectors and to prevent oil from flowing out of the cylinder when the cylinder is removed.

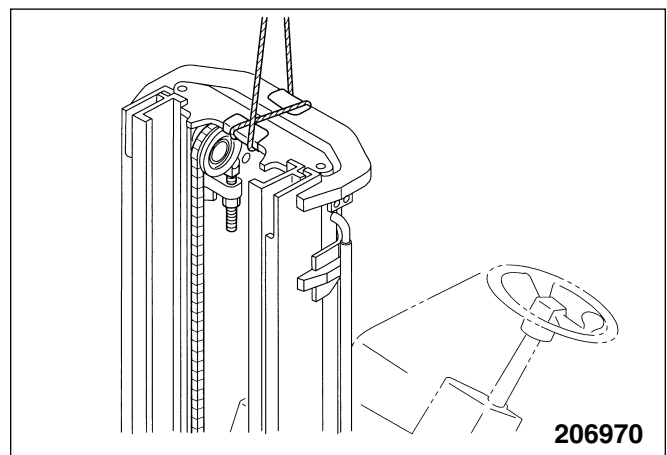

206970

# MASTING

## Disassembly (No.6)

### Second Lift Cylinders (Triplex Mast)

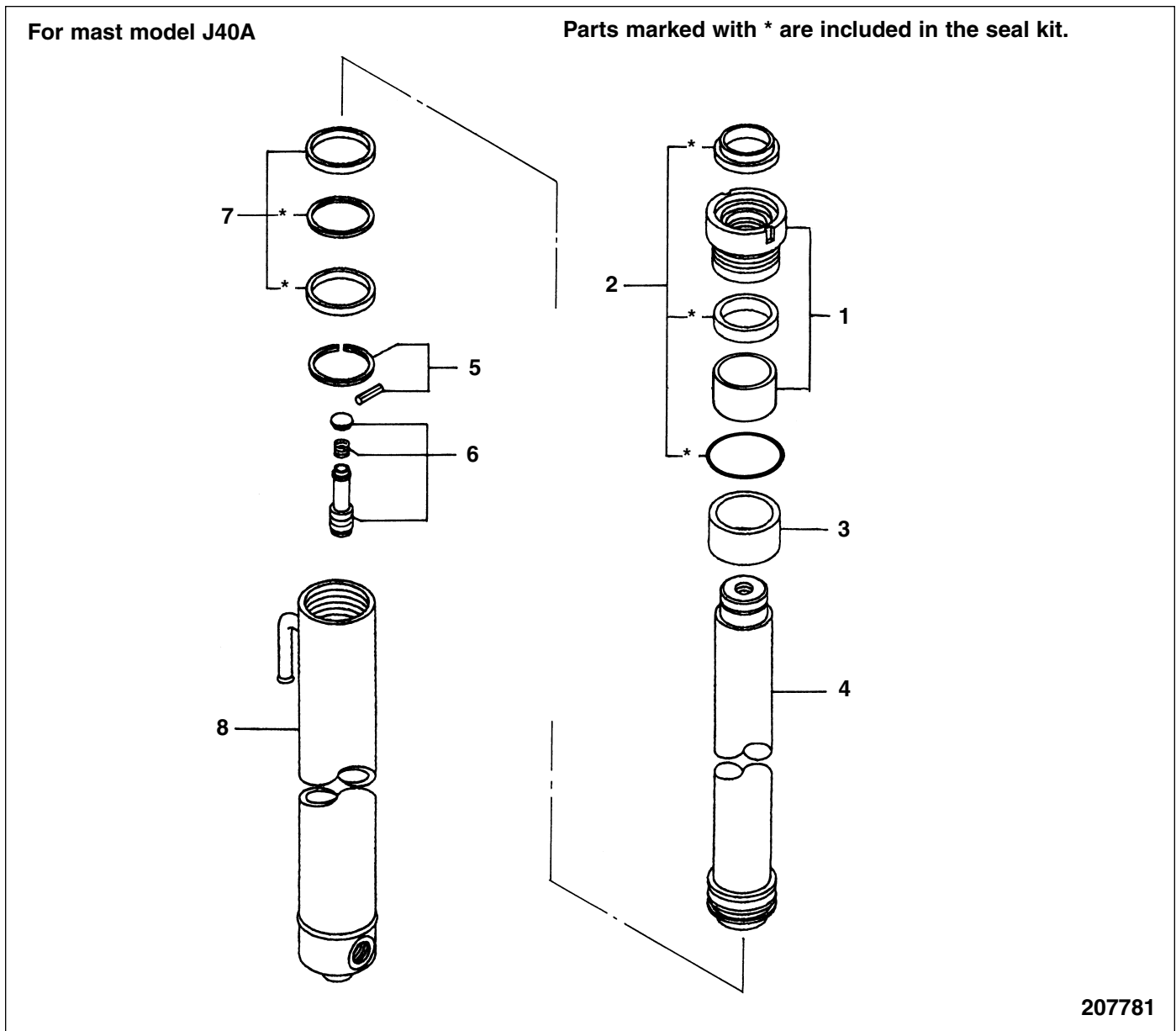

#### Sequence

- |   |                            |   |                                     |
|---|----------------------------|---|-------------------------------------|
| 1 | Cylinder head, bushing     | 5 | Snap ring, Pin                      |
| 2 | Wiper ring, U-ring, O-ring | 6 | Spring guide, Spring, Cushion spool |
| 3 | Spacer                     | 7 | U-ring, Backup ring, Bushing        |
| 4 | Piston rod                 | 8 | Cylinder tube                       |

#### NOTE

Do not remove bushing 1 from cylinder head 1 unless they are defective.

# MASTING

Complaints		Possible causes	Remedies
Lift and tilt cylinders — Continued	Bushing leaks	<ul style="list-style-type: none"> <li>a) Foreign particles lodged between sealing members such as oil seals and dust seals</li> <li>b) Oil seals and dust seals defective</li> <li>c) O-rings damaged</li> <li>d) Cylinder distorted</li> </ul>	<p>Replace.</p> <p>Replace.</p> <p>Replace.</p> <p>Repair or replace.</p>
	Hydraulic tank heats excessively	<ul style="list-style-type: none"> <li>a) Oil viscosity improper</li> <li>b) Overload</li>   <li>c) Local overheating of oil line due to a large restriction to flow</li> <li>d) Relief valve adjustment improper</li>   <li>e) Pressure drop due to fatigued or broken springs</li> <li>f) Gear pump worn</li> <li>g) Outlet pipe or tube deformed, or restricted</li> </ul>	<p>Change oil.</p> <p>Check working conditions and, if overloaded, advise the operator to stay within the load limit.</p> <p>Repair or replace.</p> <p>Readjust pressure setting.</p> <p>19.12<sup>+0.5</sup><sub>0</sub> MPa (195<sup>+5</sup><sub>0</sub> kgf/cm<sup>2</sup>) [2773<sup>+70</sup><sub>0</sub> psi]</p> <p>Repair or replace and readjust.</p> <p>Replace.</p> <p>Repair or replace.</p>
Hydraulic tank	Cylinders move too slow	<ul style="list-style-type: none"> <li>a) Shortage of oil due to a natural loss</li> <li>b) Oil leakage due to damaged oil line seals</li> <li>c) Oil viscosity too higher</li> </ul>	<p>Refill.</p> <p>Repair or replace.</p> <p>Change oil.</p>
Gear pump	Cylinders move too slow	<ul style="list-style-type: none"> <li>a) Gear pump defective</li> <li>b) Oil leakage from oil line</li>   <li>c) Abnormal oil temperature rise</li>   <li>d) Gear pump internally leaking</li> </ul>	<p>Check pump and piping; repair or replace.</p> <p>Check oil for level and condition; add or change oil.</p> <p>Check control valve spools for misalignment; repair or replace.</p> <p>Replace pump.</p>
	Noise	<ul style="list-style-type: none"> <li>a) Poor pumping</li> <li>b) Cavitation</li> </ul>	<p>Refill.</p> <ol style="list-style-type: none"> <li>1) Check suction pipe for any flat portion or loose connection; retighten or replace.</li> <li>2) Check shaft oil seal for airtightness; replace pump.</li> <li>3) Check pump case for any outside interference; repair.</li> </ol>

# TABLE OF CONTENTS

---

Reassembly . . . . .	10-23
<b>Inspection and Adjustment</b>	
Forks . . . . .	10-25
Chain, Chain Wheel Support and Chain Wheel . . . . .	10-26
Chain Tension Adjustment	
Dual-stage Panoramic Mast (Simplex Mast) . . . . .	10-27
Dual-stage Full Free Panoramic Mast (Duplex Mast) . . . . .	10-28
Triple-stage Full Free Panoramic Mast (Triplex Mast) . . . . .	10-29
Clearance Adjustment on Lift Bracket . . . . .	10-30
Mast Clearance Adjustment . . . . .	10-32
Main Roller Shim Replacement (Simplex Mast) . . . . .	10-34
Procedure for Replacing Main Roller Shims [Dual Stage Full Free Panoramic Mast (Duplex Mast)] . . . . .	10-35
Procedure for Replacing Main Roller Shims [Triple-stage Full Free Panoramic Mast (Triplex Mast)] . . . . .	10-36
Mast Strip Adjustment . . . . .	10-38
<b>Tilt Angle Adjustment . . . . .</b>	<b>10-38</b>
<b>Lift Cylinder Stroke Adjustment . . . . .</b>	<b>10-39</b>
<b>Troubleshooting - Mast . . . . .</b>	<b>10-40</b>
<b>Service Data . . . . .</b>	<b>10-41</b>
<b>Simplex Mast / Duplex Mast . . . . .</b>	<b>10-42</b>
<b>Triplex Mast . . . . .</b>	<b>10-43</b>

## MAST AND FORKS

- (2) Position the mast upright. Raise the inner mast until main rollers 8 of the lift bracket become free. Then, slowly move the vehicle in reverse to separate from bracket 2
2. Separating mast and tilt cylinders.
  - (1) Lower the inner mast. Hitch a sling to the upper cross-member of the outer, middle and inner masts. then lift with a crane.



### CAUTION

**Be sure to use a hoist having a capacity enough to support the mast assembly.**

- (2) Place wood blocks under the tilt cylinder mounting sections, and remove pins 3. Start the engine, and pull back the tilt lever to retract the tilt cylinder rods.
- (3) Disconnect high-pressure hose 5 for lift cylinders.
2. Removing mast.
  - (1) Raise and block middle and inner mast channels.
  - (2) Remove the bolts and collet. Remove shaft from mast mount

### NOTE

**Lay the mast assembly on a floor large enough to disassemble the parts.**

3. Remove the blocks and lower the mast. Fasten straps and a hoist to the mast. Lift off the mast assembly. Lay it down flat on a level floor.
4. Removing lift cylinder high pressure hoses. Place the mast in the bottom position, disconnect the hoses at the flow regulator valve.
5. Removing tilt cylinders
  - (1) Hitch a sling to the upper cross-member of the outer and inner masts, then lift with a crane.



### CAUTION

**Be sure to use a hoist having a capacity enough to support the mast assembly.**

- (2) Remove the tilt socket pins, and separate the masts from the tilt cylinders.
- (3) Turn the key on, and pull back the tilt lever to retract the tilt cylinder rods.
- (4) Disconnect the high-pressure hose for lift cylinders.

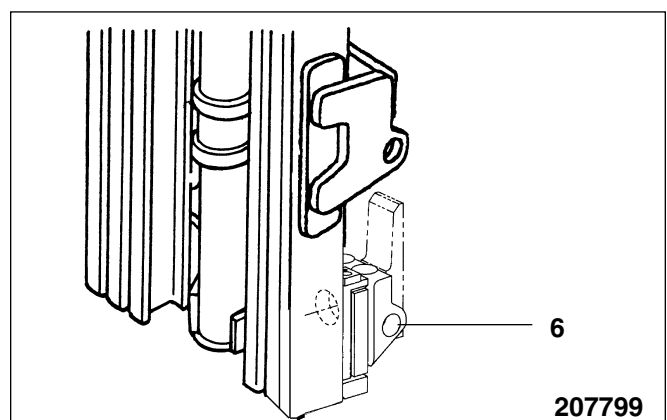
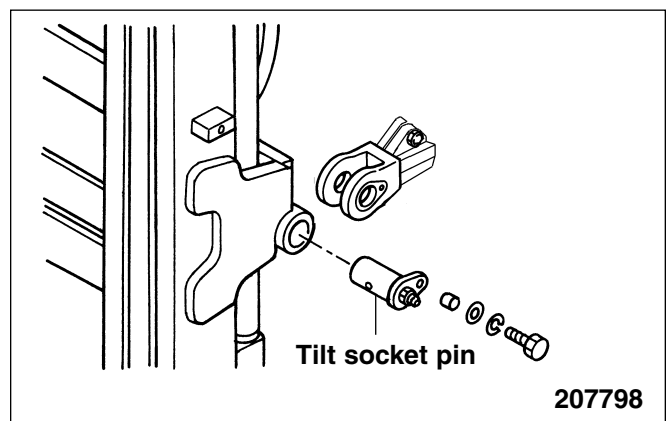
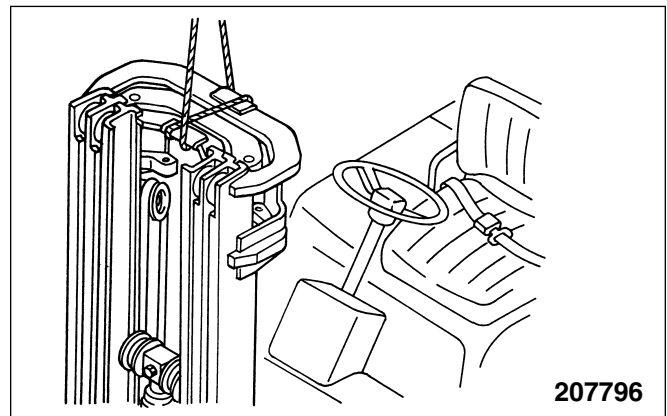
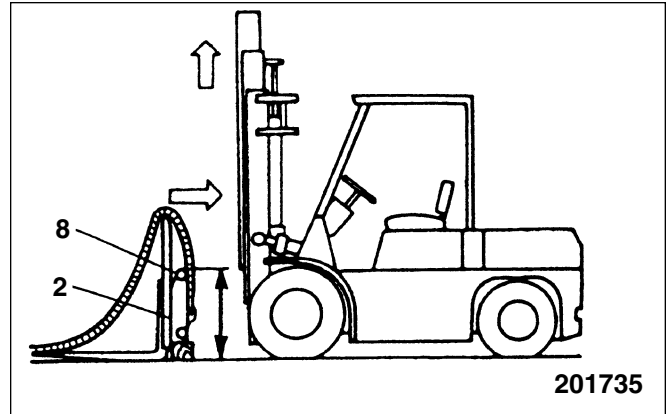

## MAST AND FORKS

- (4) If the left-to-right clearance of the main roller is not adequate, adjust the clearance by increasing and decreasing shims a and b, following the adjustment procedure for main roller clearance between outer mast and inner mast.

### NOTE

Use the main roller at the upper end of the lift bracket to ensure the front-to-back clearance. Use side rollers to ensure the left-to-right clearance.

### 5. Installing lift cylinder

To prevent bend force on the lift cylinder, install lift cylinder vertically to the mast when the mast is at the lowest position. If any defect is found, adjust with shims.

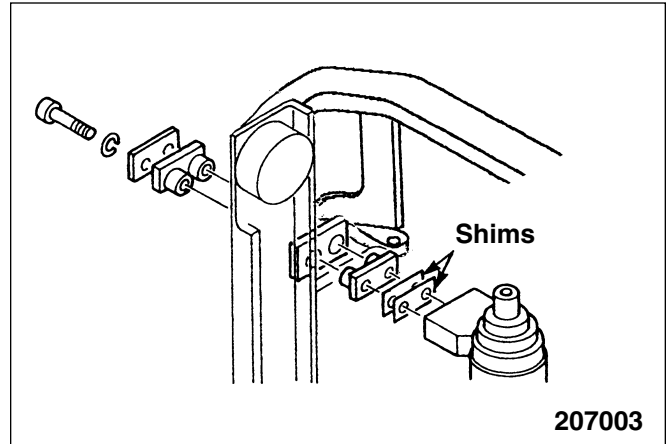

### 6. Cautions for assembling chain anchor kit

Never assemble the center plate to the assembling position of link plate.

- (1) Link plate (with stamp on surface)
- (2) Center plate (no stamp on surface)
- (3) Link
- (4) Split pin

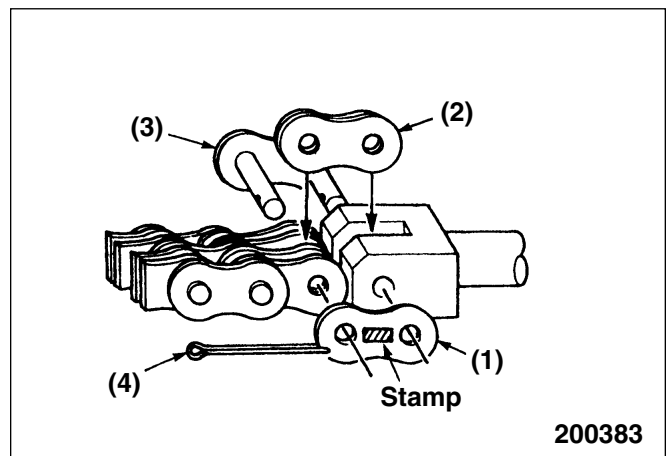

### 7. Installing first lift cylinder

Install the first lift cylinder of duplex mast so that the lift cylinder is vertical to the mast when the lift cylinder rod is at the lowest position.

Make sure that the cylinder does not tilt forward but tilts backward at fitting B against A by 0 to 0.5 mm (0 to 0.02 in.). Use shims for adjustment.

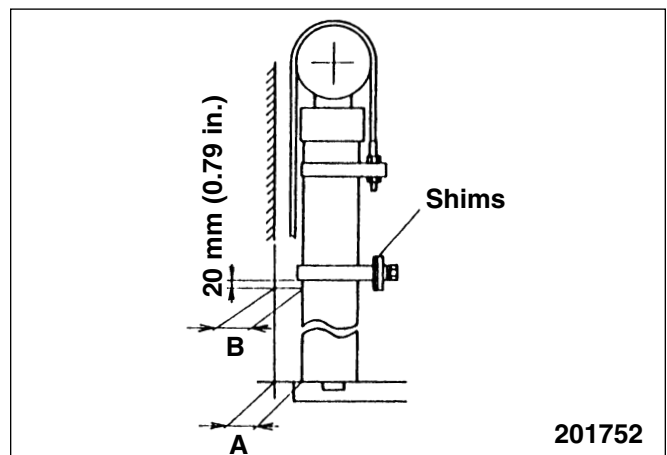

# MAST AND FORKS

## Clearance Adjustment on Lift Bracket

**NOTE**

The adjustment procedure for the lift bracket is the same for the Simplex Mast, Duplex Mast and Triplex Mast.

1. Longitudinal clearance adjustment on lift bracket main rollers
  - (1) Raise the forks a little from the floor.
  - (2) Insert a bar between the upper part of lift bracket and the inner mast, and push the inner mast to one side. Using feeler gauges, measure the clearance F between the main roller and inner mast on the opposite side.

Clearance F	0.1 to 1.0 mm (0.004 to 0.039 in.)
-------------	---------------------------------------

- (3) If the clearance F is out of specification, use oversized rollers.

### Roller sizes

Unit: mm (in.)

Diam. of main roller	40A	45A 55A
S	117 (4.60)	129 (5.08)
M	118 (4.64)	130 (5.12)
L	119 (4.68)	131 (5.16)
LL		

- (4) Lift bracket main rollers (upper and center rollers) The upper rollers should be the same in size or 1-rank larger than the center rollers.
2. Lateral clearance adjustment on lift bracket main rollers and side rollers
  - (1) Raise the mast to the top.
  - (2) Set a dial indicator on the inner mast with its contact point rested on the side of the lift bracket.
  - (3) Go over to the opposite side of the mast, and push the lift bracket to one side with a bar. Set the indicator to zero.
  - (4) Insert a bar between the inner mast and lift bracket on the indicator side, and push the lift bracket to the opposite side.
  - (5) Read the indicator.

Clearance G1	0.1 to 0.5 mm (0.004 to 0.020 in.)
--------------	---------------------------------------

- (6) Adjust clearance G1 between the center main roller and weld plate ② at the maximum lift position by increasing or decreasing the thickness of the shim.

Do not install a shim at upper main roller ①.

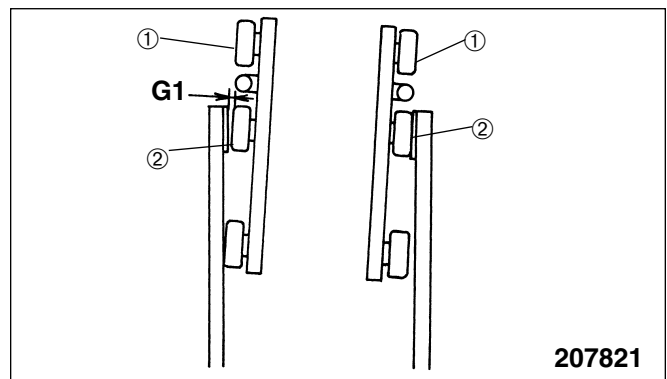
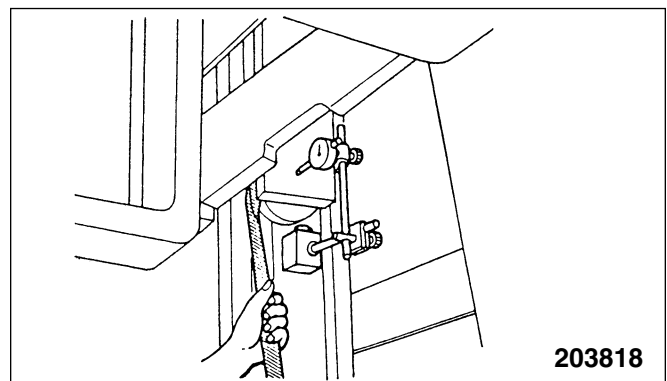
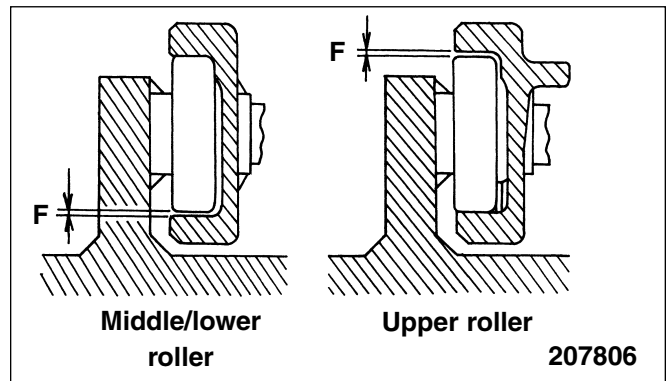
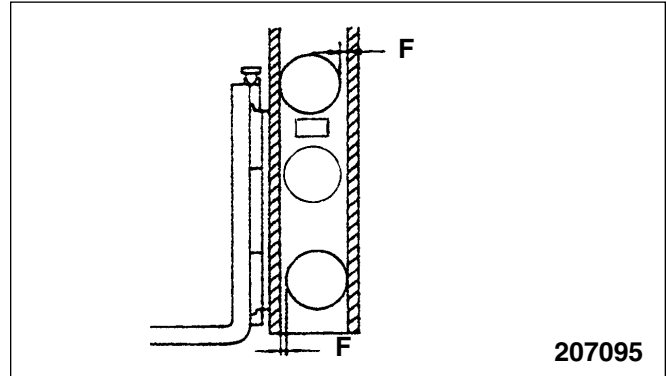

# MAST AND FORKS

## Troubleshooting

Complaints	Possible causes	Remedies
Lift bracket and inner mast will not move smoothly	a) Clearance between lift rollers and side rollers incorrect b) Rollers binding on their shafts c) Lift chains strained in movement d) Mast strip clearance incorrect	Readjust clearance, see page 11-32 Relubricate or replace. Relubricate or replace. Shim adjust. 0.1 to 0.5mm (0.004 to 0.020 in.)
Lift bracket or inner mast binds	a) Too much clearance on side rollers  b) Lift chains unequally tensioned c) Shim adjustments unequally made on between left and right lift cylinders (at maximum height)	Readjust by means of shims. 0.1 to 0.5mm (0.004 to 0.020 in.) Readjust, see page 11-27 Readjust, see page 11-39
Mast makes noise	Rollers not rotating smoothly on their shafts	Relubricate or replace.
Load descends (drift)	a) Lift cylinder packing damaged b) Sliding (inside) surface of lift cylinder tube damaged	Replace. Replace.
Whole mast shakes	Mast-support bushing or metal worn	Retighten or replace, see page 11-42
Mast is distorted	Off-center loading or overload	Replace mast assembly.
Fork tips differ in height	a) Finger bar bent b) Forks bent c) Un-even loading	Repair or replace. Repair or replace. Repair or replace.

Second lift cylinders operate while first lift cylinder is moving. [Triple-stage full free panoramic mast]

- Low oil temperature
- Insufficient clearances between lift bracket rollers and sliding surfaces
- Clogged pipe
- Insufficient air bleeding

- Increase oil temperature to 40-50 °C.
- Readjust rollers.
- Inspect and clean hydraulic lines.
- Bleed air completely.

Lift bracket is spongy when it stops in lifting operation.

- Insufficient air bleeding

- Bleed air completely.

CLICK HERE TO **DOWNLOAD** THE COMPLETE MANUAL

- Thank you very much for reading the preview of the manual.
- You can download the complete manual from: [www.heydownloads.com](http://www.heydownloads.com) by clicking the link below



- Please note: If there is no response to CLICKING the link, please download this PDF first and then click on it.

CLICK HERE TO **DOWNLOAD** THE COMPLETE MANUAL