



# Service Manual

## Chassis & Mast

### GC15K

AT81C-00011-up  
AT81D-00011-up  
AT81E-00011-up

### GC25K

AT82C-00011-up  
AT82D-00011-up  
AT82E-00011-up

### GC18K

AT81C-00011-up  
AT81D-00011-up  
AT81E-00011-up

### GC25K HP

AT82C-90011-up  
AT82D-90011-up  
AT82E-90011-up

### GC20K

AT82C-00011-up  
AT82D-00011-up  
AT82E-00011-up

### GC30K

AT83C-00011-up  
AT83D-00011-up  
AT83E-00011-up

### GC20K HP

AT82C-90011-up  
AT82D-90011-up  
AT82E-90011-up

CLICK HERE TO **DOWNLOAD** THE COMPLETE MANUAL

- Thank you very much for reading the preview of the manual.
- You can download the complete manual from: [www.heydownloads.com](http://www.heydownloads.com) by clicking the link below



- Please note: If there is no response to CLICKING the link, please download this PDF first and then click on it.

CLICK HERE TO **DOWNLOAD** THE COMPLETE MANUAL

## Serial Number Locations

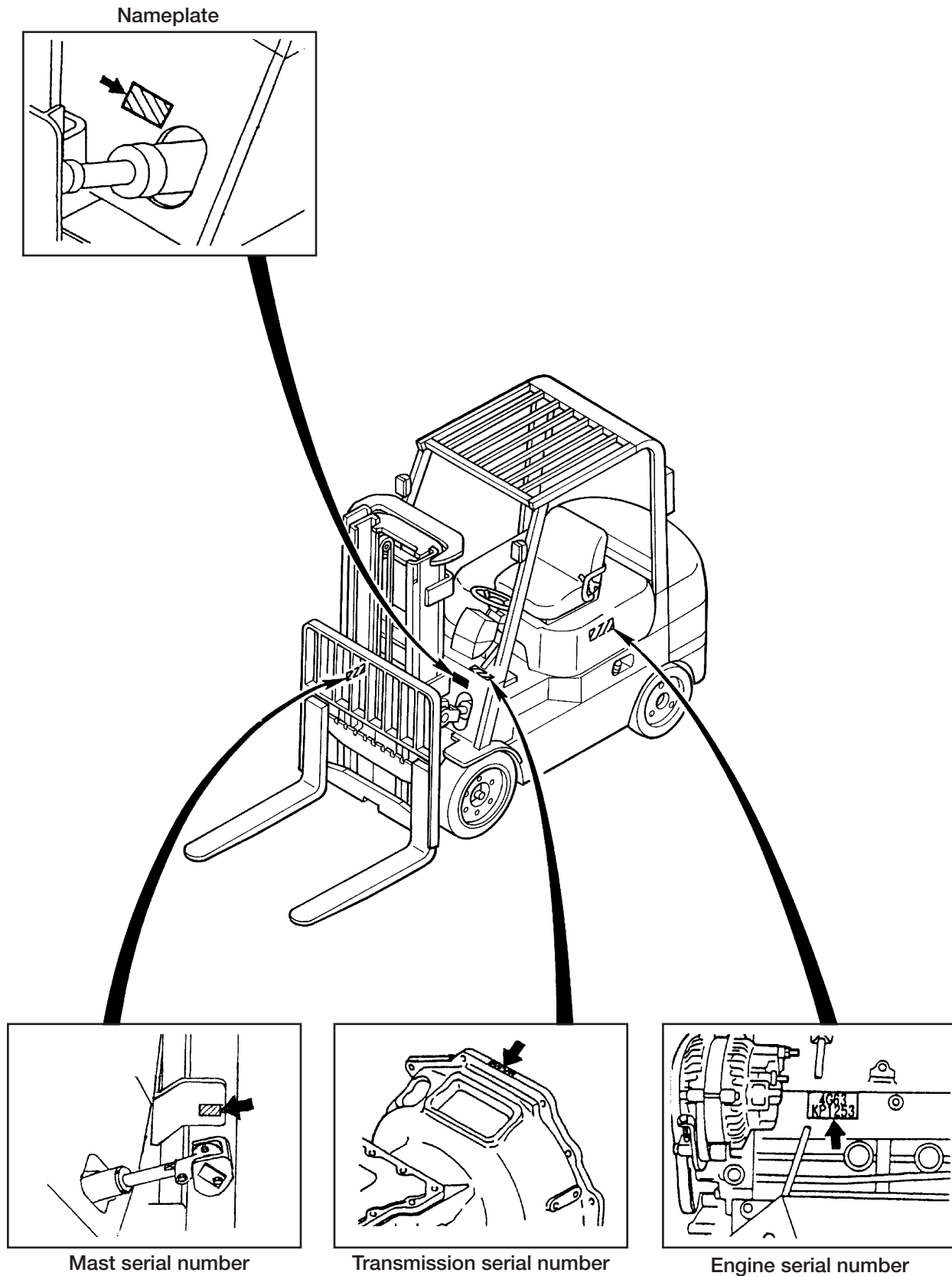

## Structure and Function

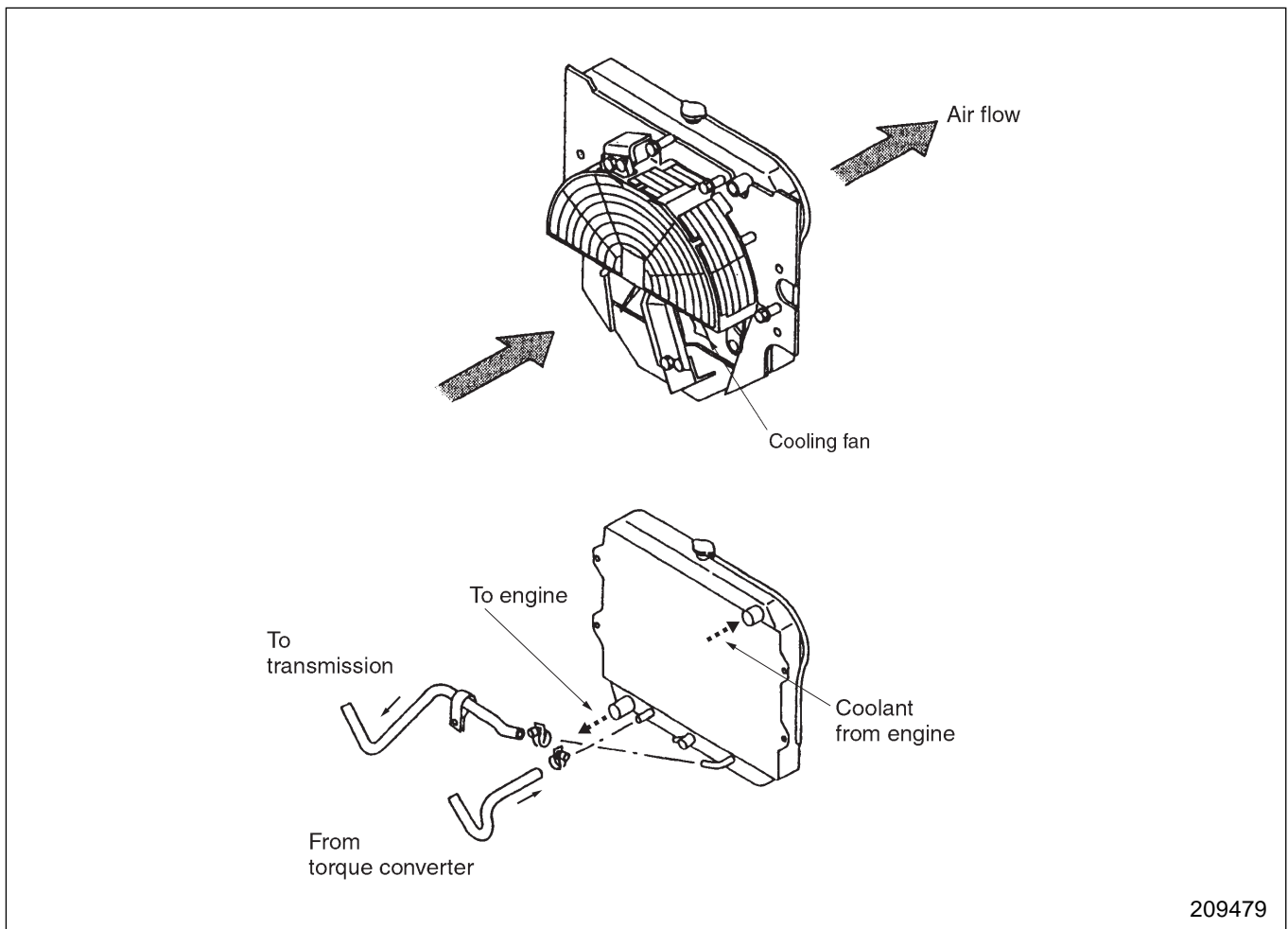

The cooling fan is installed inside the engine compartment. This helps minimize radiator core clogging and retain high cooling efficiency even in continuous operation for hours. The radiator's lower tank has a built-in transmission oil cooler.

## Major Electrical Components

### Starter Switch (with Anti-Restart Lock)

This switch has a built-in anti-restart lock, so the key cannot be turned from I (ON) to Ⓢ (START) position while the engine is running.

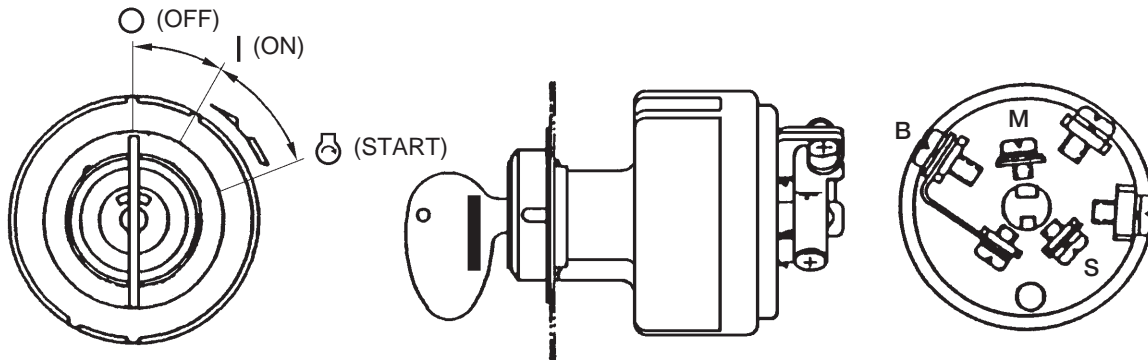

203561A

#### Connection Chart

Terminal	B	M	S
Component	Fuse box, battery, alternator	Fuse box, fuel-cut solenoid	Starter, neutral switch (powershift transmission models)
Key position			
○ (OFF)	○		
I (ON)	○ —	○	
Ⓢ (START)	○ —	○ —	○

## Removal and Installation

### Removal of Engine, Transmission (Torque Converter), Reduction Gear and Differential

#### NOTE

Separate the engine-power line combination from the front axle housing at the differential carrier.

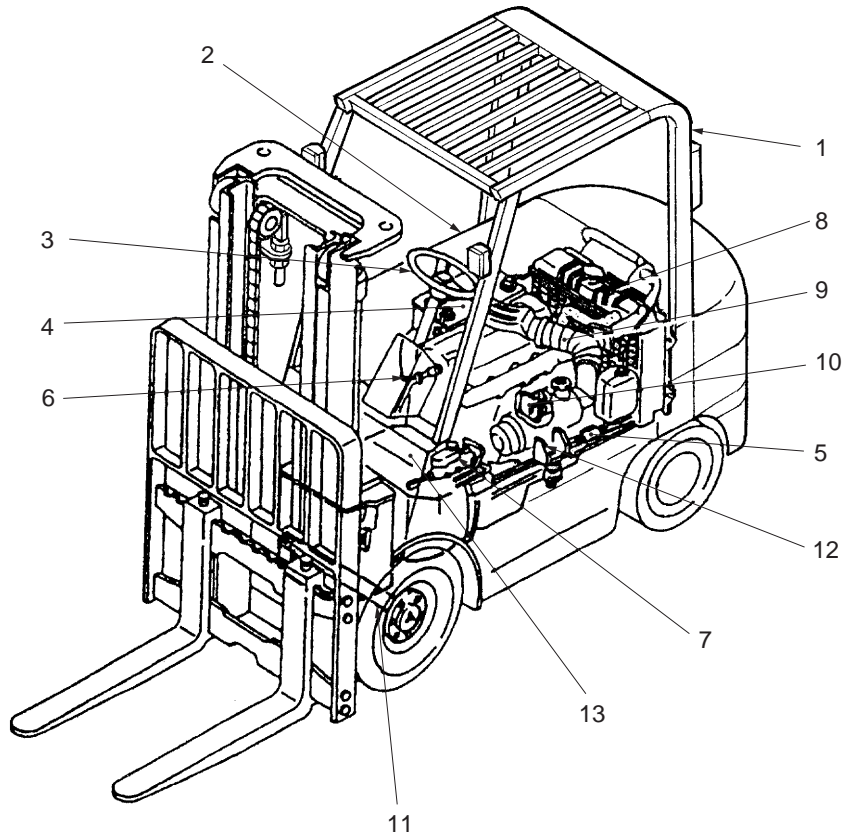

205946

#### Sequence

- |   |   |
|---|---|
| 1 Overhead guard  | 7 Master cylinder                       |
| 2 Engine cover, Front cover, Floor plate,<br>Radiator cover | 8 Radiator hoses, Radiator              |
| 3 Steering wheel  | 9 Air cleaner rubber hose, Exhaust pipe |
| 4 Battery, Power line harness                               | 10 Universal joint                      |
| 5 Fuel hose, Accelerator pedal linkage                      | 11 Front axle shaft                     |
| 6 Choke cable   | 12 Engine mounting bolt                 |
|   | 13 Power line                           |

## Control System

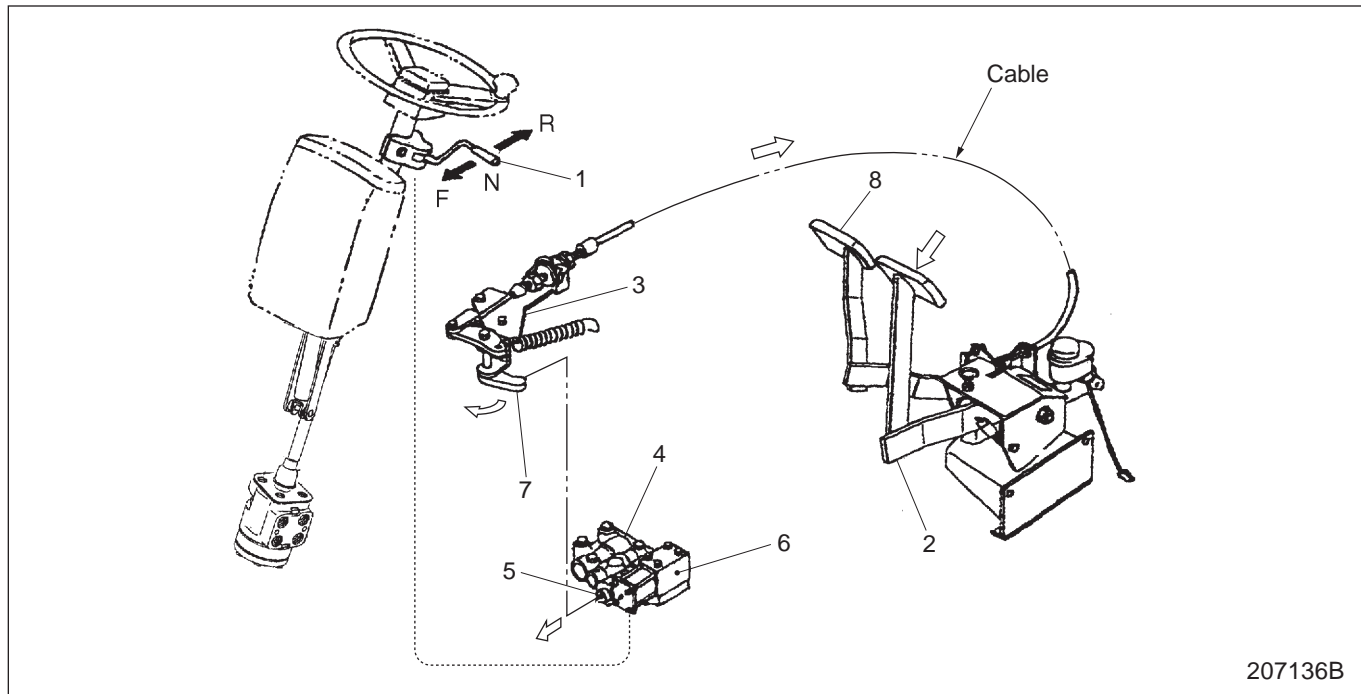

207136B

### Main components

- |   |  |
|---|--|
| 1 Directional control lever (F-N-R shift lever) | 6 Forward-reverse selector valve (solenoid valve assembly) |
| 2 Clutch (inching) lever                        | 7 Inching lever  |
| 3 Bracket (inching)                             | 8 Brake pedal  |
| 4 Control valve assembly                        |  |
| 5 Clutch valve plunger                          |  |

The operator can perform two types of control on the transmission : forward-reverse switching and inching.

### Forward-reverse switching

When the operator moves directional control lever 1 into the F or R position, electric current flows to the F or R solenoid to cause the plunger in the solenoid to move. The spool connected to the plunger then moves and allows pressure oil to flow to the forward or reverse clutch to engage the clutch. This completes the engine power path from the output shaft to the differential.

Speed control is achieved only by way of the accelerator pedal. With lever 1 in the neutral position, solenoid in the selector valve is not energized, so the valve spool remains in the neutral position. Neither of the clutches is then engaged and no power is transmitted to the output shaft.

### Inching

When the operator depresses inching pedal 2, the cable connected to the pedal pulls inching lever 7, causing it to turn in the direction of the arrow. Clutch valve plunger 5 having been held retracted in the valve body by the lever until then is moved out by the force of the spring in the direction of the arrow. When the plunger moves out, the pressure oil passage to the clutch is throttled and, at the same time, the pressure oil being supplied to the clutch is drained, causing the pressure to drop. As the pressure reduces, the clutch becomes engaged only partially. The amount of oil drained depends on how much the inching pedal is depressed.

When inching pedal 2 is depressed, the brake pedal follows the inching pedal movement. As soon as the clutch pressure drops to zero, the brakes starts working. Using inching pedal 2 alone, the operator can make partial clutch engagement and braking controls.

**Suggestions for Disassembly**

**1. Removing idler gear shaft ball bearing**

Use a gear puller.

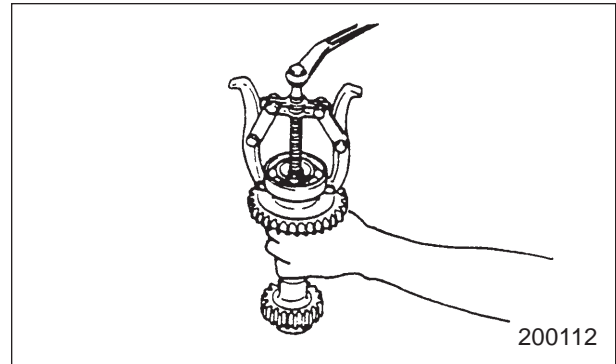

**2. Removing output shaft**

- (1) Use bevel pinion puller (special tool) to remove the output shaft. The shaft will come out, leaving the output gear behind in the transmission case.

Special tool needed

Bevel pinion puller	91868 - 02100 or 91268 - 00300
---------------------	--------------------------------------

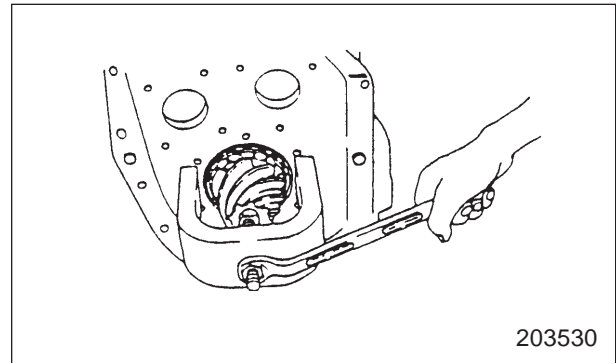

- (2) Use a press to remove the bearing from the output shaft.

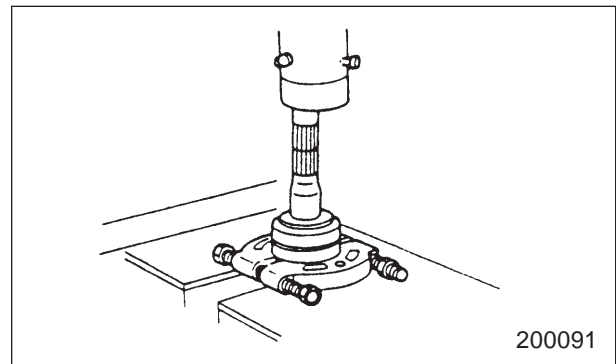

**3. Removing input shaft ball bearing**

Use a special tool to remove the ball bearing from the input shaft.

Special tool needed

Ref. No.	Part name	Part No.	Q'ty
1	Puller	91268 - 13810	2
2	Plate	91268 - 13820	1
3	Bolt	F1035 - 10020	2
4	Gear puller T-24 (Banzai make)	-	1

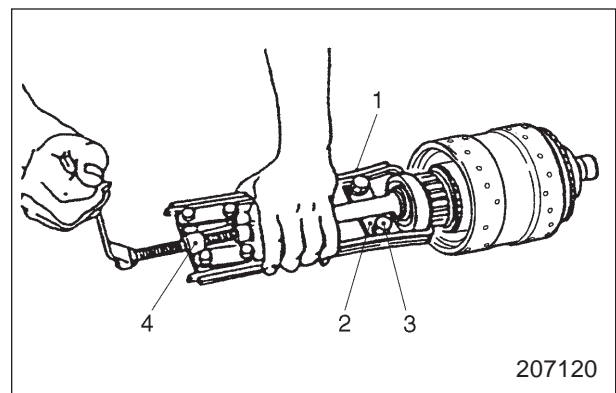

## Inspection and Adjustment

### Testing Hydraulic Pressure

1. Run the engine at low idle for a while. Stop the engine and , one minute later, check the oil level in the transmission with the oil level gauge.
2. Warm up until the transmission oil temperature rises.
3. Check the no-load minimum and maximum speeds of the engine. If the speeds are not correct, make an adjustment by referring to SERVICE MANUAL for the engine.

Unit: rpm

Truck Model Item	GC15K GC18K	GC20K/20K HP GC25K/25K HP GC30K
No-load minimum speed	700 ± 50	700 ± 50
No-load maximum speed	2600	2600 to 2650

4. After checking the engine speeds, stop the engine. Raise the front wheels. To do this, jack the front axle housing, or place wood blocks under the outer mast and tilt the mast forward.

 **CAUTION**

The front wheels will rotate when the clutch pressure is tested.

5. Connect a pressure gauge to the tap for a pressure to be tested. The pressure taps are located as shown.

 **WARNING**

To reduce the risk of personal injury, when the hydraulic pressure is tested, move the truck to a clear area, that is level. Keep all other personnel away from the truck. Use lifting equipment or a safe method to lift the front of the truck until the front wheels are off the floor. Put wood blocks or jack stands of the correct capacity under it to hold it in this position while pressure tests are performed.

**Service Data**

A: Standard value B: Repair or service limit

Unit: mm (in.)

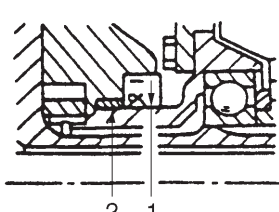
Item		Truck Model	GC15K GC18K	GC20K GC25K	GC20K HP GC25K HP GC30K
Stall speed (tolerance ± 100 rpm)		rpm	A	2130	1780 1960
Main pressure	At 1600 ± 100 engine rpm kPa (kgf/cm <sup>2</sup> ) [psi]	A	930 to 1180 (9.5 to 12.0) [135 to 171]		
	At 800 ± 50 engine rpm kPa (kgf/cm <sup>2</sup> ) [psi]	B	785 (8) [144], min		
	At 2500 ± 100 engine rpm kPa (kgf/cm <sup>2</sup> ) [psi]	B	785 to 1177 (8 to 12) [114 to 171]		
Clutch pressure	At 1600 ± 100 engine rpm kPa (kgf/cm <sup>2</sup> ) [psi]	A	930 to 1180 (9.5 to 12.0) [135 to 171]		
	At 800 ± 50 engine rpm kPa (kgf/cm <sup>2</sup> ) [psi]	B	785 (8) [144], min		
	At 2500 ± 100 engine rpm kPa (kgf/cm <sup>2</sup> ) [psi]	B	785 to 1177 (8 to 12) [114 to 171]		
Torque converter inlet pressure	At 1600 ± 100 engine rpm kPa (kgf/cm <sup>2</sup> ) [psi]	A	100 to 490 (1 to 5) [14.3 to 71]		
	At 800 ± 50 engine rpm kPa (kgf/cm <sup>2</sup> ) [psi]	B	98 (1) [14]		
	At 2500 ± 100 engine rpm kPa (kgf/cm <sup>2</sup> ) [psi]	B	98 to 588 (1 to 6) [14 to 85]		
Torque converter outlet pressure	At 1600 ± 100 engine rpm kPa (kgf/cm <sup>2</sup> ) [psi]	A	100 to 490 (1 to 5) [14.3 to 71]		
	At 800 ± 50 engine rpm kPa (kgf/cm <sup>2</sup> ) [psi]	B	49 (0.5) [7]		
	At 2500 ± 100 engine rpm kPa (kgf/cm <sup>2</sup> ) [psi]	B	49 to 343 (0.5 to 3.5) [7 to 50]		
Lubricating oil pressure	At 1600 ± 100 engine rpm kPa (kgf/cm <sup>2</sup> ) [psi]	A	98 to 147 (1 to 1.5) [14 to 21]		
10-m (33 ft) starting acceleration (no load)		sec	A	Within 5	
Pump boss	Outside diameter of surface of boss for oil seal 1	A	55 <sup>0</sup> <sub>-0.030</sub> (2.17 <sup>0</sup> <sub>-0.000118</sub> )		
		B	54.90 (2.1614)		
	Inside diameter of bushing 2	A	55.155 to 55.225 (2.17145 to 2.17421)		
		B	55.4 (2.181)		
					
	200409				

5. Raise the front end of the truck. Use any of the following three methods.

**⚠ WARNING**

- (1) Do not replace the tire when the truck is loaded to prevent possible personal injury.
- (2) Be sure to get off the truck when raising the front tire.
- (3) Stop raising the truck when the tire just clears the ground. Do not raise the truck more than is necessary to prevent possible personal injury.
- (4) Do not put any portion of your body under the truck. Securely support the truck by blocks after raising it.

Method 1 — Position the jack under the frame and raise the truck until the tire clears the floor.

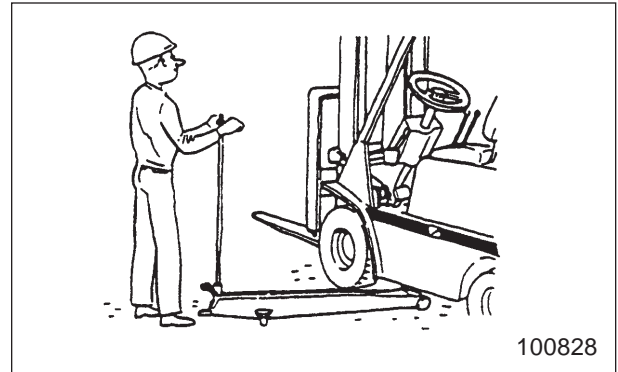

Method 2 — Tilt the mast all the way back, place wood blocks under the mast, and tilt the mast forward.

**⚠ CAUTION**

After raising the front end, securely support it by blocks.

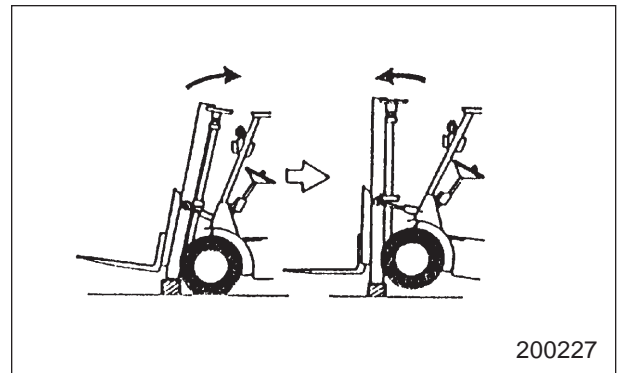

Method 3 — Fasten a hoist to the mast and lift the front end of the truck as shown.

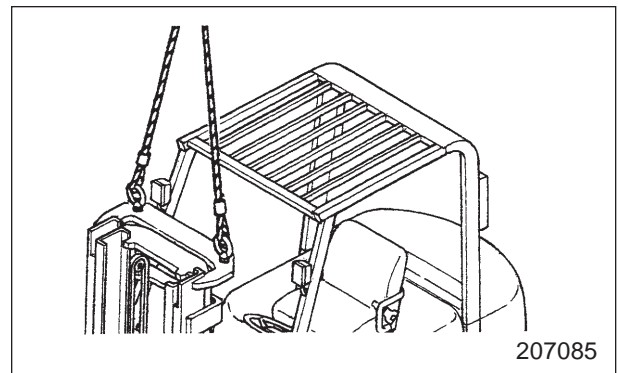

Reassembly

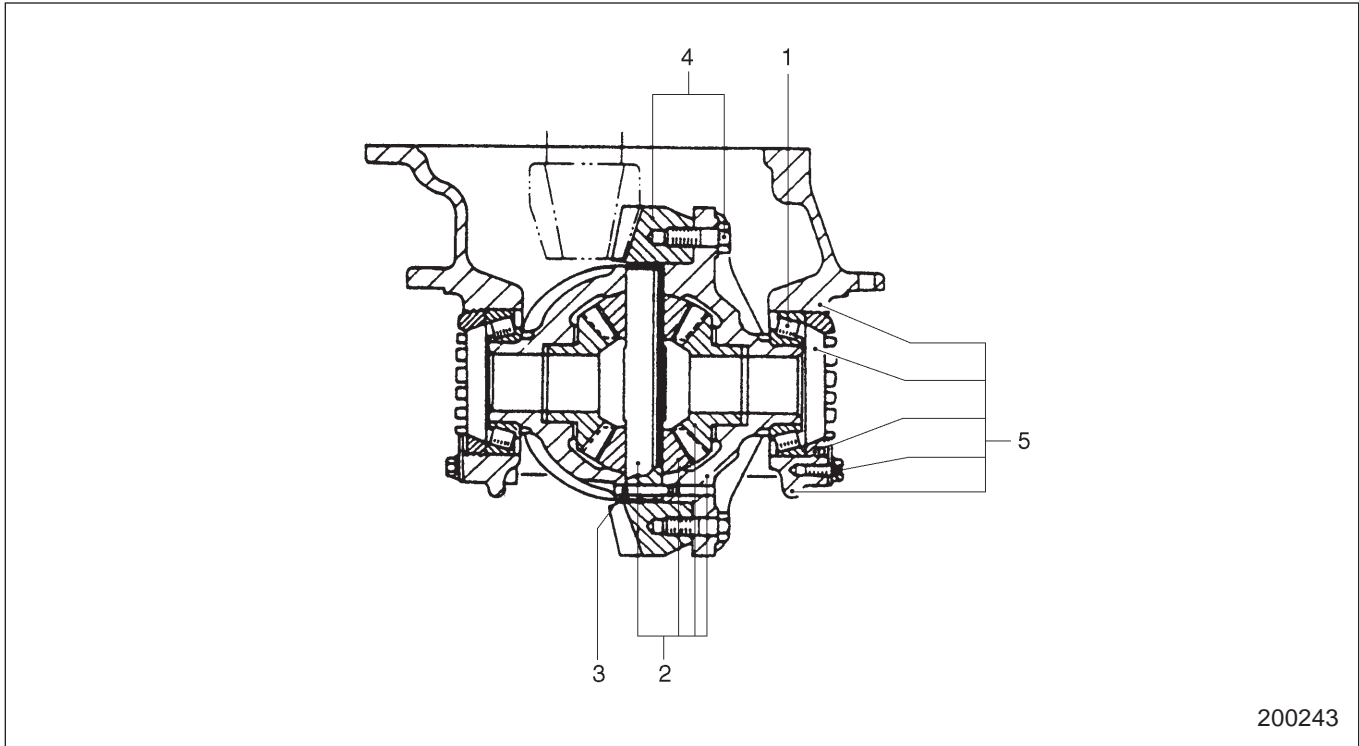

200243

**Sequence**

- |  |   |
|--|---|
| <p>1 Taper roller bearings</p> <p>2 Differential gear assembly<br/>This assembly consists of (must be factory-assembled unit):<br/>Differential case, Thrust washers, Bevel gears, Pinions, Pinion shaft</p> | <p>3 Spring pin</p> <p>4 Reduction gear</p> <p>5 Carrier, Side bearing caps, Side bearing nuts, Lock washers, Bolts, Lock plate, Lock washer, Bolts</p> |
|--|---|

**Suggestions for Reassembly**

**1. Reassembling differential pinions**

The thrust washers of the differential gears are to be used for adjusting the backlash between the differential gears and pinions. Measure the backlash and, if it exceeds the limit, replace the thrust washers.

A: Standard value    B: Repair or service limit  
Unit: mm (in.)

Backlash between differential gears and pinions	A	0.18 to 0.23 (0.0071 to 0.0091)
	B	0.5 (0.020)

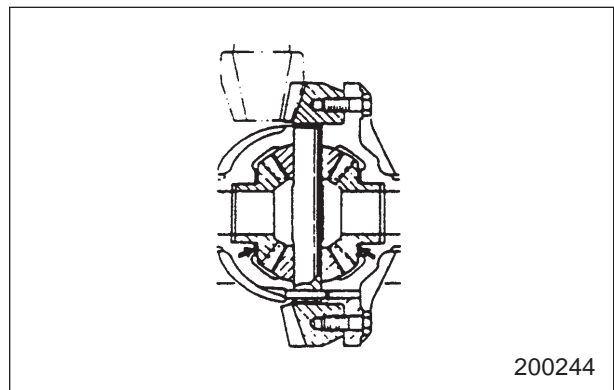

200244

## Structure and Function

### Rear Axle

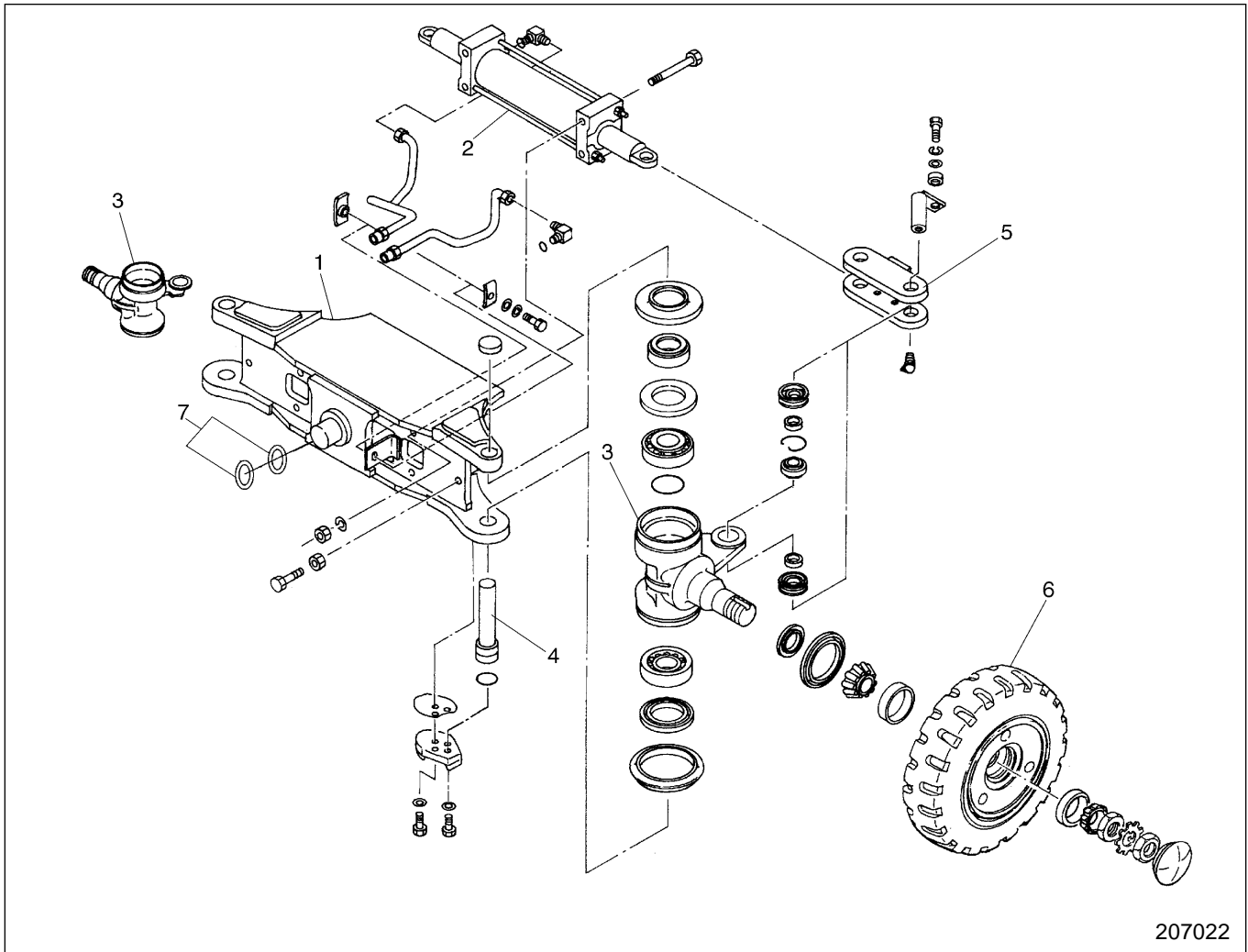

- |   |                   |   |                |
|---|-------------------|---|----------------|
| 1 | Rear axle         | 5 | Tie rods       |
| 2 | Steering cylinder | 6 | Wheel assembly |
| 3 | Steer knuckles    | 7 | Shims          |
| 4 | King pins         |   |                |

The truck is steered by the rear wheels. The rear axle is connected to the frame by its center pivot shaft. Because of the center pivoting feature, the rear axle can oscillate up to 3° in each direction.

## Suggestions for Disassembly

### 1. Removing retainer and bearing

Use a puller to remove the retainer and bearing cone from the knuckle.

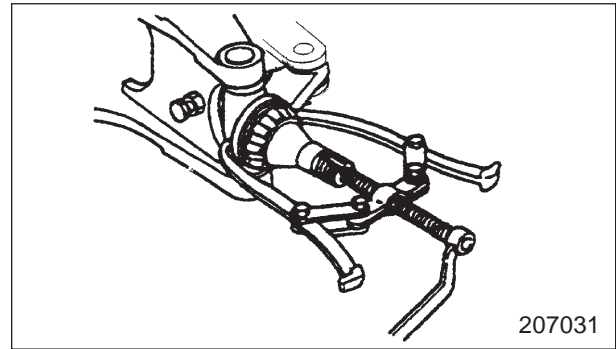

## Inspection after Disassembly

### 1. Tie rods and pins

- (1) Make sure that the pins are free of any surface flaws such as grooving or stepped wear. Examine the tie rod pin weld for cracking.
- (2) Examine the bearings for wear or damage.
- (3) Examine the tie rods for damage and alignment. Inspect the welds for signs of cracks.

#### NOTE

If a pin must be replaced, replace its bearing as well.

### 2. Kingpins

Check the kingpins for any surface flaws such as grooving or stepped wear. Inspect the pins for cracks at the bearing shoulder.

### 3. Kingpin bearings

Examine the rollers and bearing races for grooving, abrasive wear, pitting, bruising, or corrosion. Replace both the cup and cone of damaged bearings.

### 4. Knuckles

Inspect the inside of each knuckle for wear or damage. Be sure to examine for casting cracks. Check the tie rod pin hole. Examine the wheel nut threads for damage.

### 5. Seals and O-rings

Examine all seals and O-rings for damage such as cuts and tears. Replace seals which show signs of aging.

### 6. Hydraulic pipes

Inspect the hydraulic pipes for cracks, especially at the joints with the end fittings. Check for leaks.

### 7. Cylinder rod

Examine the rod for surface or plating damage. Inspect the rod for straightness. Examine the piston for damage check the tie rod pin hole for damage or wear.

**Service Data**

A: Standard value    B: Repair or service limit

Unit: mm (in.)

Item		Truck Model		GC15K GC18K		GC20K/20K HP GC25K/25K HP GC30K		
Rear Axle	Oscillating angle	A		3°				
	Toe-in	A		0°				
	Caster	A		0°				
	Camber	A		1°				
	Total fore-aft play of axle at center pin 1	A		0.8 (0.031)				
		B		1.2 (0.047)				
	Turning angle	Inside 2	A		82°	80°		
		Outside 3	A		59°	55°		
	Tightening torque for support bolts 4 N·m (kgf·m) [lbf·ft]		A		145 (14.8) [107]			
	Tightening torque for knuckle stopper bolt lock nuts 5 N·m (kgf·m) [lbf·ft]		A		67 (6.8) [49]			
Cylinder minimum test pressure kPa (kgf/cm) [psi]		A		10500 (107) [1522]	16000 (163) [2320]			

207043

## Disassembly and Reassembly

### Master Cylinder

#### Disassembly

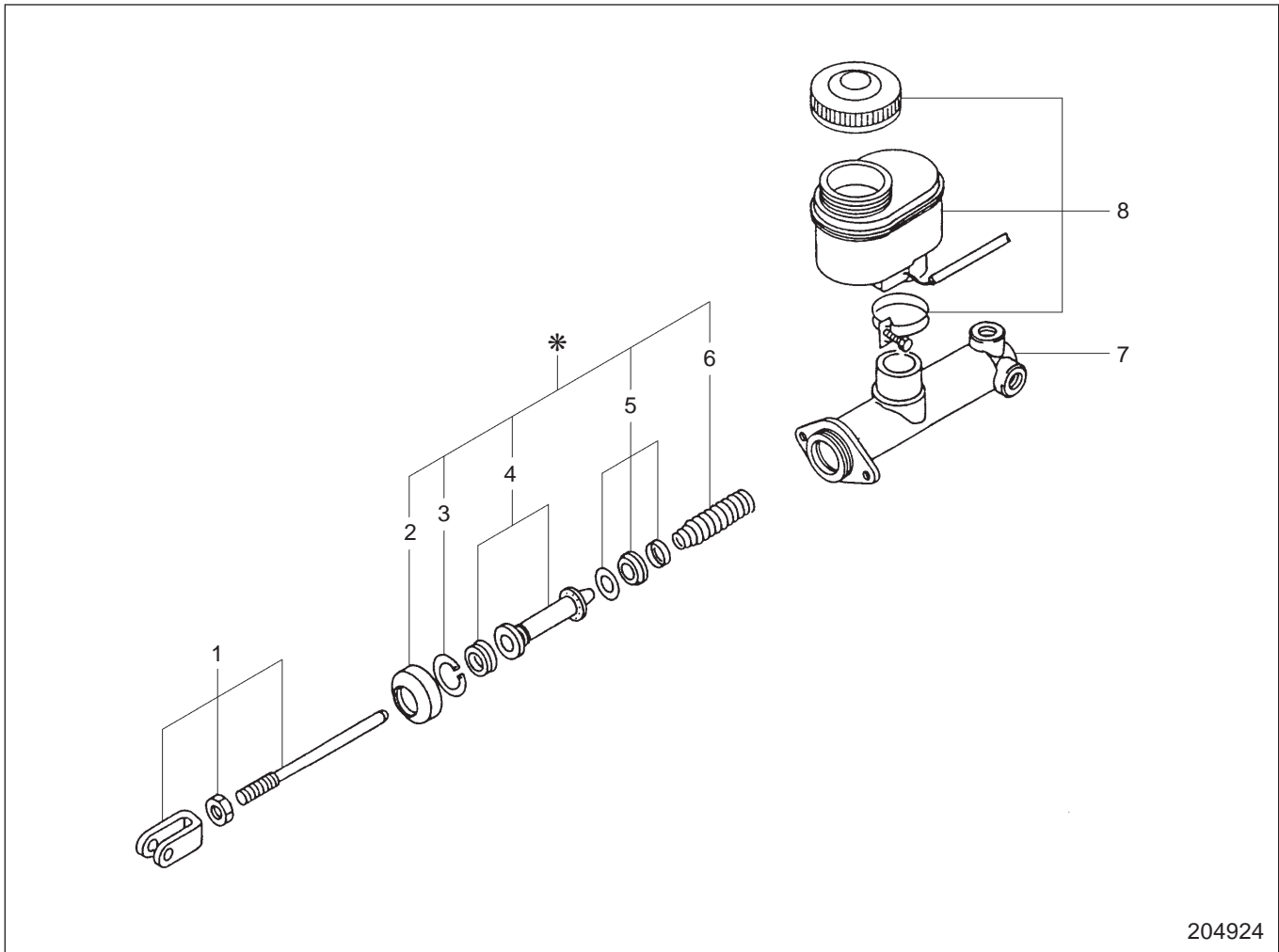

#### Sequence

- |                                 |  |
|---------------------------------|--|
| 1 Clevis, Locknut, and Push rod | 5 Spring seat, Primary cup, and Cup spacer |
| 2 Boot                          | 6 Return spring                            |
| 3 Snap ring                     | 7 Cylinder body                            |
| 4 Secondary cup and Piston      | 8 Reservoir and Wire band                  |

#### NOTE

The parts (\*) to be changed periodically are included in the Repair Kit.

## Inspections and Adjustment

### 1. Operational test of automatic adjusting device

(1) Set the wheel brake properly, and adjust the drum-to-lining clearance to the specification. Pull the adjusting lever while pushing the cable, as shown, to see if the lever turns the adjusting screw by one tooth and, as the push is removed, returns to the original position. If it does, the device is in satisfactory condition.

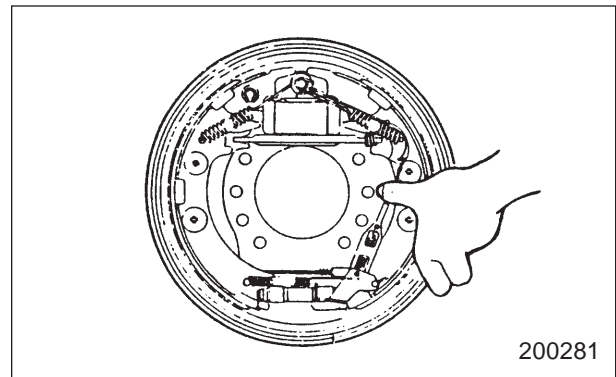

(2) If the lever fails or is sluggish to turn the adjusting screw in the above test, the possible cause is that the lever is not properly positioned relative to the toothed wheel. Be sure that the lever is so positioned that its actuating tip touches the toothed wheel at a level about 9 mm (0.35 in.) under the center line of the screw, as shown.

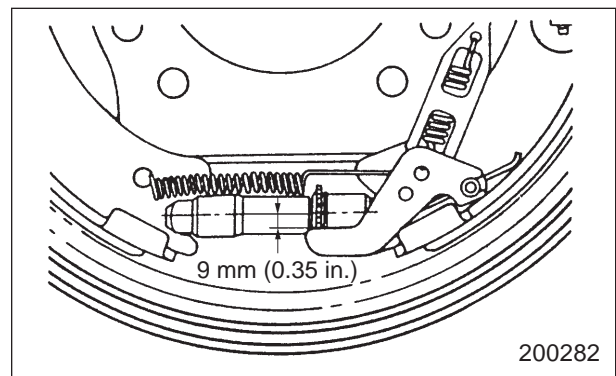

(3) Where the automatic adjusting device is suspected of malfunctioning during normal use of the machine, the following possible causes must be considered:

- (a) Adjusting spring is not correctly hooked to primary shoe.
- (b) Any of these parts is in bad condition to require replacement:
  - i) fitting cable, ii) adjusting lever, and iii) adjusting screw.

### 2. Manual adjustment

The drum-to-lining clearance can be adjusted by rotating the adjusting screw with a screwdriver put to the toothed wheel. The hole through which the screwdriver tip can be inserted is provided in the backing plate.

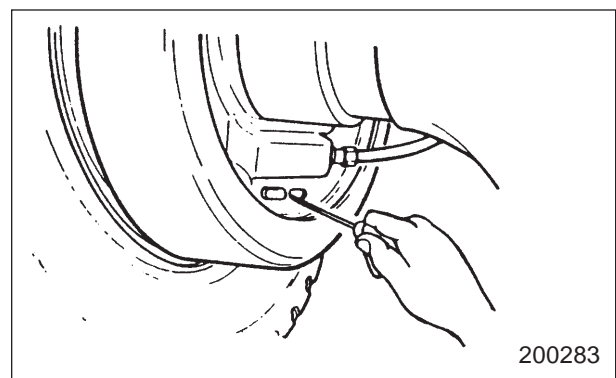

Unit: mm (in.)

Truck Model	GC15K GC18K	GC20K/20K HP GC25K/25K HP GC30K
Item		
Clearance between drum and lining	0.25 to 0.5 (0.009 to 0.019)	0.1 to 0.35 (0.004 to 0.013)

## Structure and Functions

### General

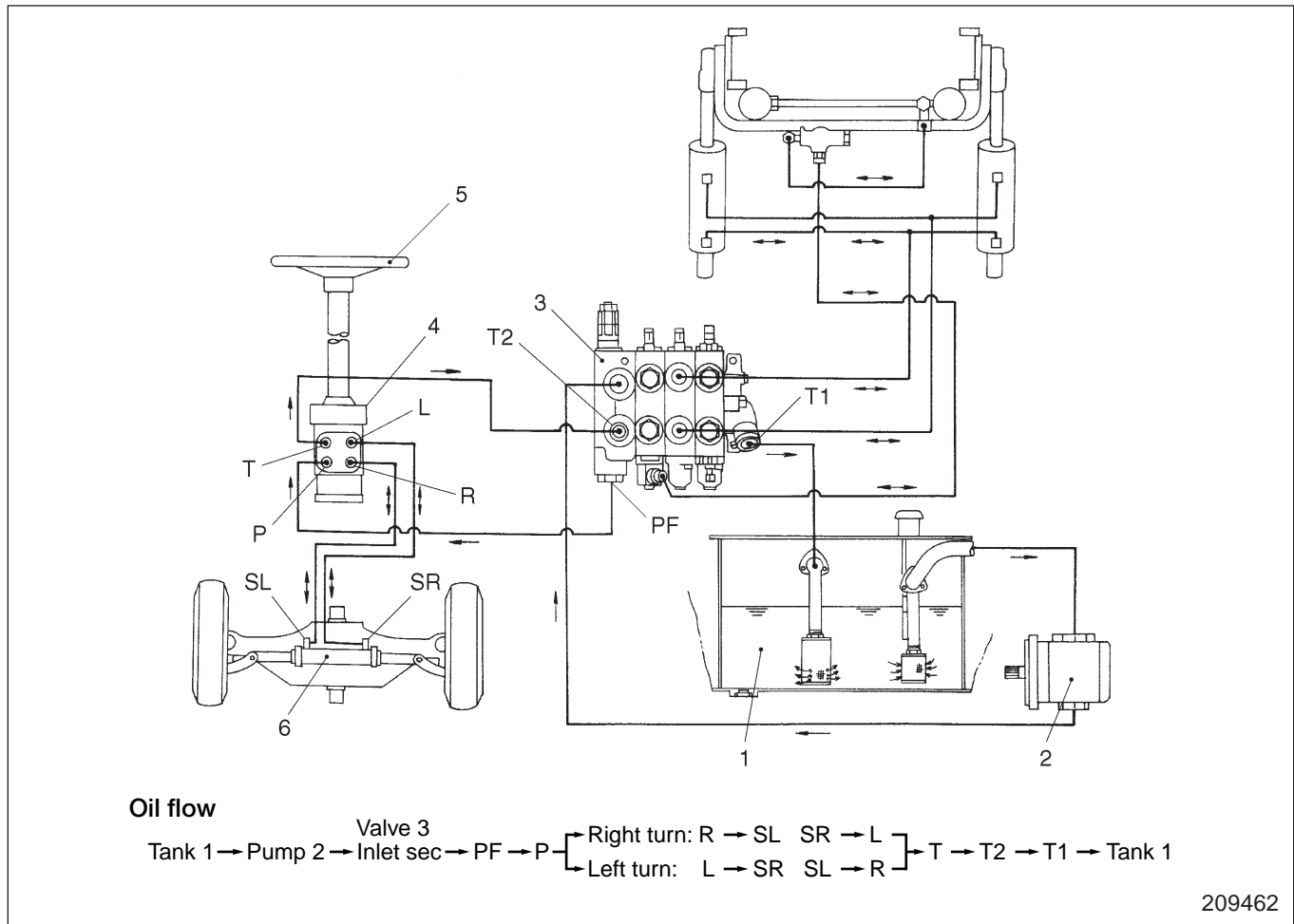

### Main steering system components

- |  |                     |
|--|---------------------|
| 1 Tank (hydraulic)   | 4 Steering gear     |
| 2 Hydraulic pump   | 5 Steering wheel    |
| 3 Inlet section of hydraulic valve<br>(with built-in flow divider valve) | 6 Steering cylinder |

The steering system of this machine is operated and controlled completely hydraulically.

The oil drawn by hydraulic pump 2 from hydraulic tank 1 is forced to steering gear 4 via the flow divider valve and then through port PF in inlet section 3. When steering wheel 5 is not turned, the oil flows through port T of the steering gear to port T2 in the inlet section and then returns to hydraulic tank 1.

When the operator turns the steering wheel, the oil flows to a small hydraulic pump in the steering gear. The pump rotor, the core element of the small hydraulic

pump, rotates together with the steering wheel. When the steering wheel is turned, the pump rotor turns and forces the oil into steering cylinder 6 through port R or L of steering gear 4. This pushes the piston in steering cylinder 6 and forces the oil on the other side toward port L or R of the steering gear. The oil then goes out of the steering gear through port T and enters port T2 of the inlet section 3. From port T1 of the hydraulic control valve, the oil flows into hydraulic tank 1.

For more detail of the oil flow, refer to the “Hydraulic Schematic of Hydraulic System” section (page 11-2).

## Inspection and Repair

- (1) Inspecting sliding surfaces between the spool and the housing and between the spool and the sleeve
  - (a) Check for defective sliding movement in sub-assembly condition.
  - (b) If any defective movement is found, check sliding surfaces.
 

If any defect such as abnormal wear, rust or a scratch is found, replace the steering control valve assembly.

## Reassembly

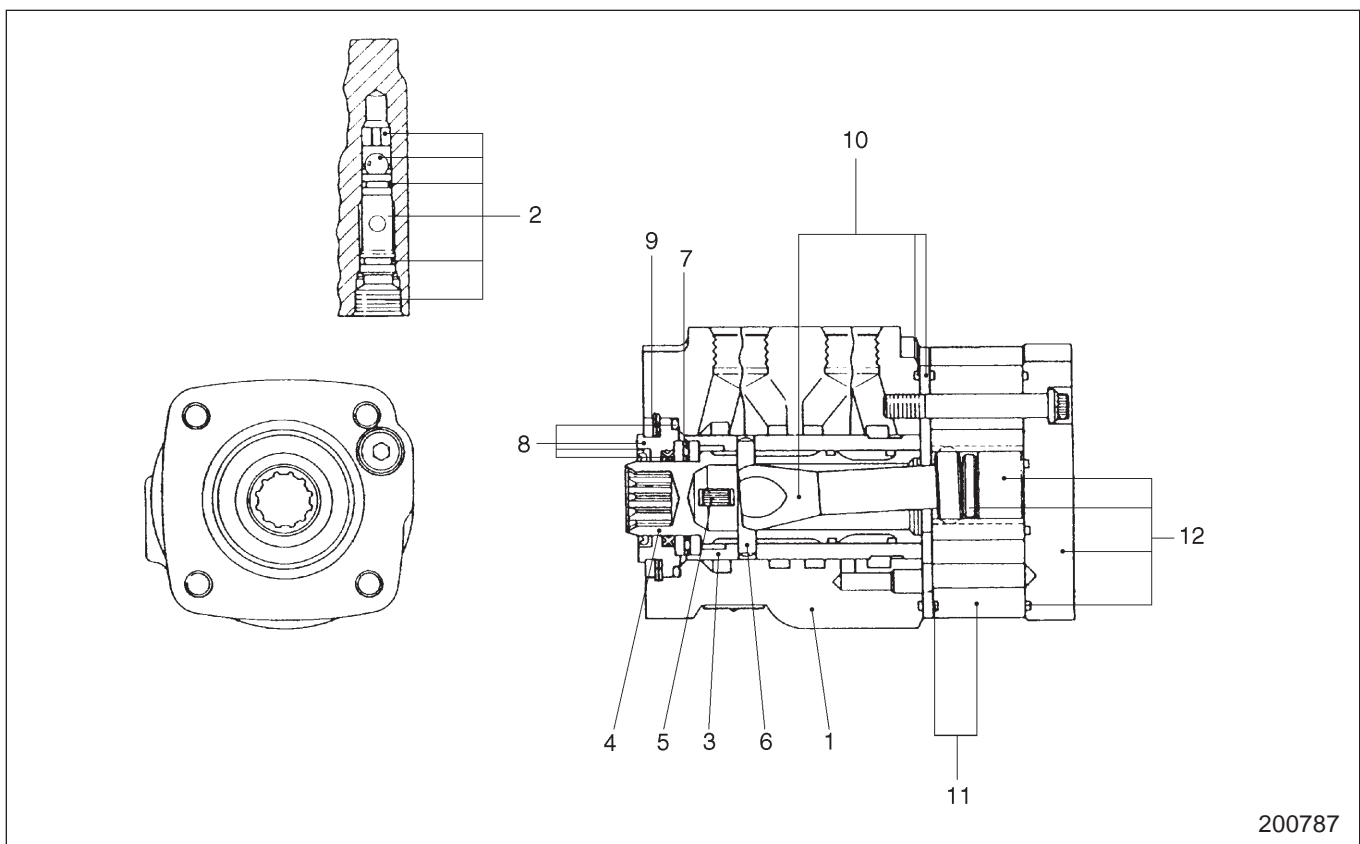

200787

### Sequence

- |   |  |
|---|--|
| 1 Long housing  | 7 Thrust needle, Race bearings                       |
| 2 Check valve, Retainer, Ball, O-ring,<br>Check seat, Set screw | 8 Seal gland bushing, Oil seal, Dust seal,<br>O-ring |
| 3 Control sleeve  | 9 Retaining ring                                     |
| 4 Control spool   | 10 Drive shaft, Spacer plate, O-ring                 |
| 5 Centering spring  | 11 "Gerotor" set, O-ring                             |
| 6 Pin   | 12 End cap, O-ring, Spacer, Bolts                    |

## Hydraulic Tank

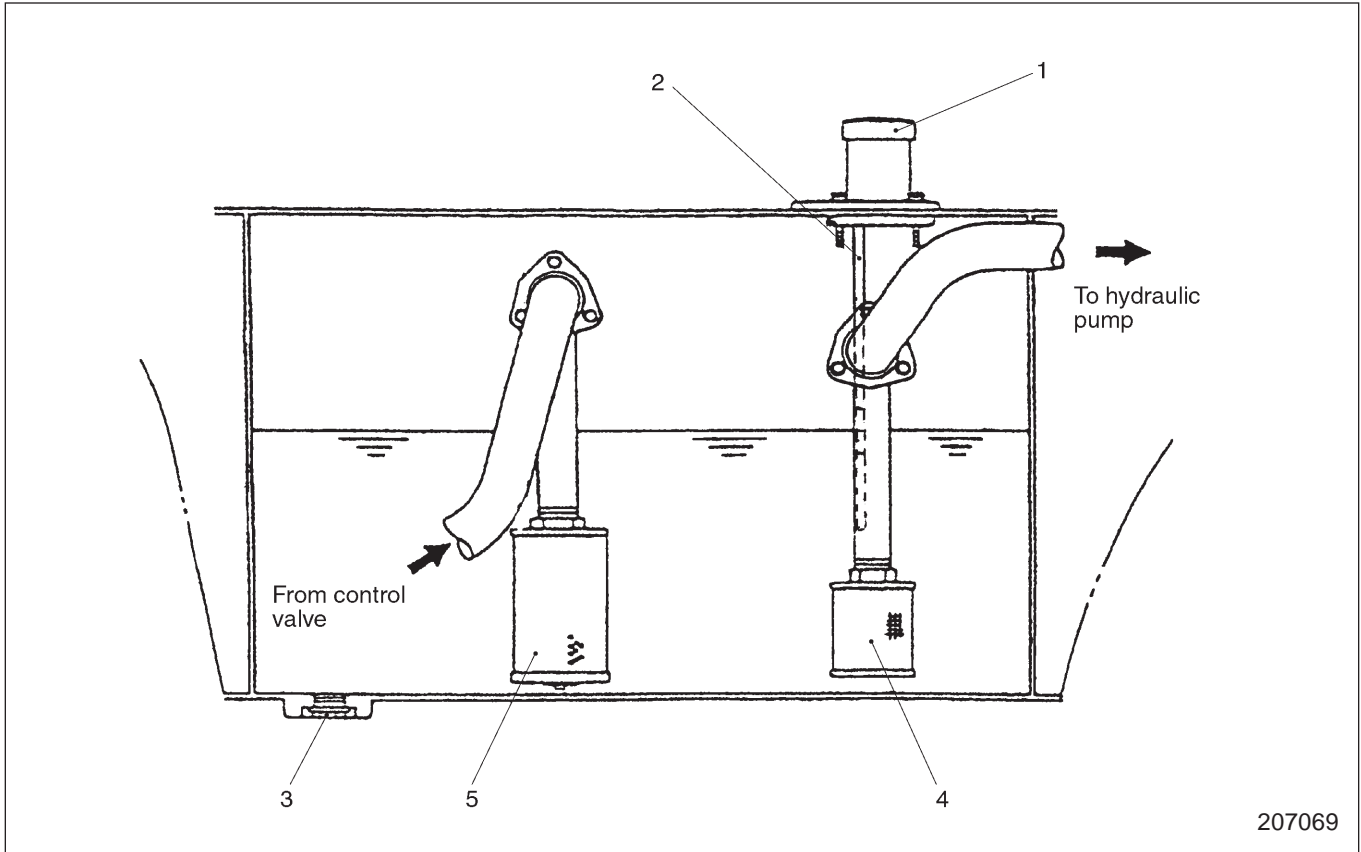

207069

- |                     |                    |
|---------------------|--------------------|
| 1 Air breather, Cap | 4 Suction strainer |
| 2 Oil level gauge   | 5 Return filter    |
| 3 Drain plug        |                    |

The tank is internally provided with two filtering means, suction strainer with a 150-mesh screen for catching gritty particles in the oil and return filter built in the relief valve and capable of catching 15-micron and larger particles in the oil returning from the control valve.

The oil level in the hydraulic tank changes as the mast is raised and lowered, causing air to flow out of and into the tank through the breather. The breather is fitted with a filter to prevent dust from entering the tank.

## Removal and Installation

### ⚠ WARNING

Hydraulic oil, under pressure can remain in the hydraulic system after the engine and pump have been stopped. Personal injury can be caused if this pressure is not released before any work is done on the hydraulic system. To prevent possible injury, lower the lift bracket to the ground, turn the engine off and move the control levers to make sure all hydraulic pressure is released before any fitting, plug, hose or component is loosened, tightened, removed or adjusted. Always move the truck to a clean and level location away from the travel of other machines. Be sure that other personnel are not near the machine when the engine is running and tests or adjustments are made.

## Hydraulic Pump

### Removal

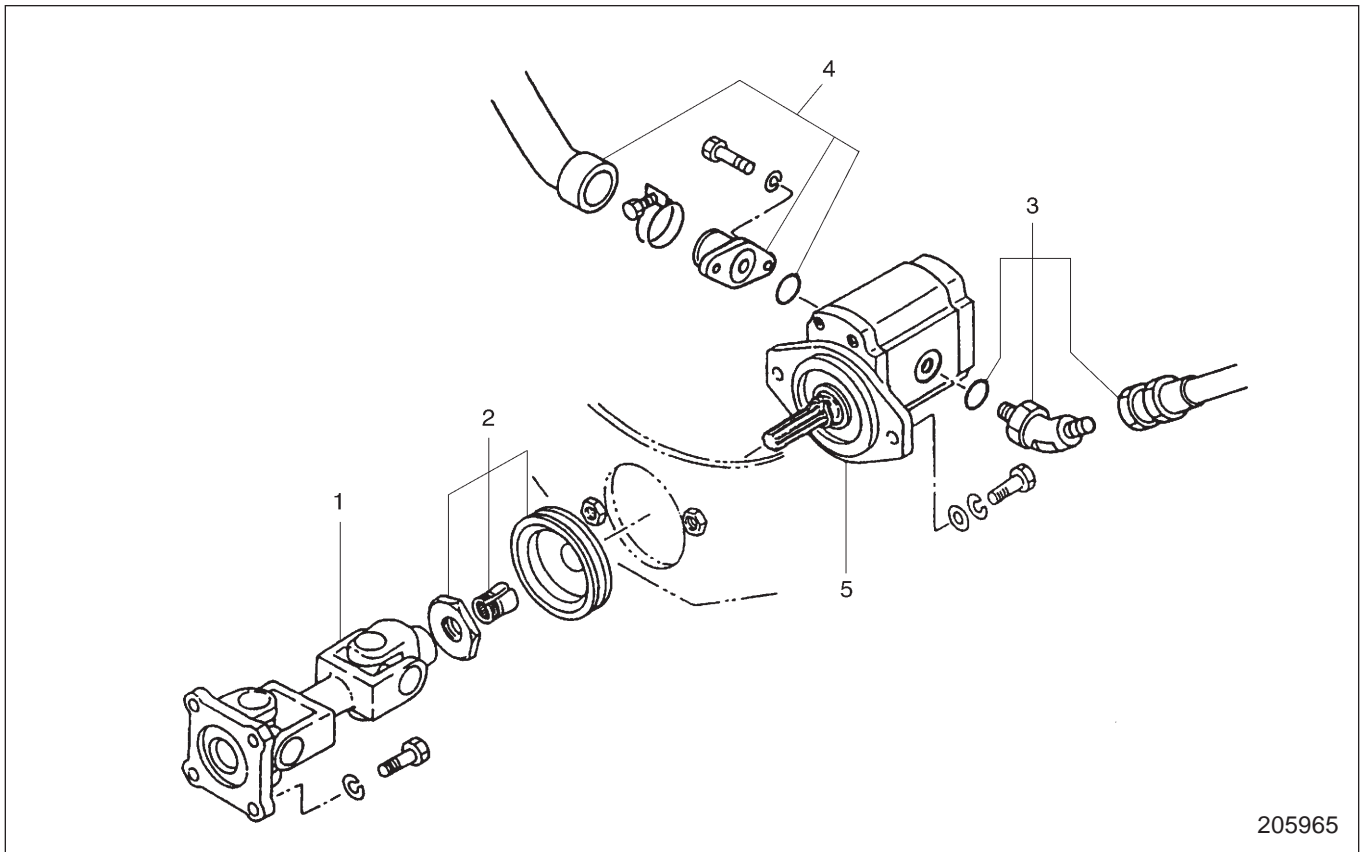

205965

### Sequence

- |                                     |                                      |
|-------------------------------------|--------------------------------------|
| 1 Universal joint                   | 4 Clamp, Suction hose, Elbow, O-ring |
| 2 Drive pulley, Lock nut, Boss      | 5 Hydraulic pump                     |
| 3 Main delivery hose, Joint, O-ring |                                      |

### Suggestions for Disassembly

- (1) Do not disassemble main relief valve 1 and steering system relief valve 2 unless it is impossible to adjust the setting of the valve.
- (2) Do not change the combination of valve housing and spool.

### Inspection and Repair

- (1) Check the valve housings for cracks and sliding surfaces for wear. Also, inspect the check valve seat for wear.
- (2) Check the spools for damage, seizure or distortion. Also, check for operating effort.

Operating effort of spool (full stroke)	157 to 216 N (16 to 22 kgf) [35.2 to 48.5 lbf]
---	--

- (3) Check the poppet (tilt lock valve) for damage or seizure.

### Reassembly

To reassemble, follow the reverse of disassembly sequence, and do the following steps:

- (1) Clean the disassembled parts with high flash-point solvent. Blow them dry with compressed air; however, this does not apply to rubber parts.
- (2) Apply hydraulic oil to the spools when inserting them into the valve blocks.
- (3) Position the poppet (tilt lock valve) correctly.
- (4) Apply grease to the O-rings when fitting them between the valve housings to prevent them from twisting.
- (5) Do not use any type of sealant.
- (6) Tighten the tie bolts (securing the valve housings) as evenly as possible to prevent distortion of the housings. Remember, a failure to follow this precaution will result in sluggish movement of the spools.

Tightening torque for tie bolts (M10, 1.25)	29.4 N·m (3.0 kgf·m) [21.7 lbf·ft]
---	--

## Inspection and Adjustment

### Hydraulic Tank

#### 1. Hydraulic oil

Check the hydraulic oil in the tank for cleanliness. Oil appearing dirty or whitish (showing more or less emulsification) must be changed must be changed.

#### 2. Hydraulic tank refill capacities

Refill capacities and the amount of oil required.



#### WARNING

Remove the hydraulic tank filler cap only after the engine has been stopped and the filler cap is cool enough to remove with your bare hand.

Unit: liter (U.S. gal.)

Truck Model \ Item	GC15K GC18K	GC20K GC20K HP GC25K GC25K HP	GC30K
Hydraulic tank refill capacities	21 (5.5)	30 (7.9)	36 (9.5)

#### NOTE

Another general rule is this: In any machine, regardless of the mast-and-attachment combination, the oil level should not be above “H” mark on the level gauge when the mast is all the way down. In addition, about 4 to 5 mm (0.16 to 0.20 in.) length of the bottom end of the gauge should be in the oil when the mast is all the way up.

#### 3. Suction strainer

Check the suction strainer for clogging or damage.

#### 4. Return filter

Check the return filter for clogging or damage.

**Service Data**

A: Standard value

Unit: mm (in.)

Item		Truck Model	GC15K GC18K	GC20K GC25K	GC20K HP GC25K HP	GC30K
Simplex mast	Lift speed (rated load) mm/sec (fpm)	A	590 (116)	510 (100)	530 (104)	470 (93)
	Lowering speed (rated load) mm/sec (fpm)	A	520 (103)	500 (98)	500 (98)	470 (93)
	Forward tilt angle	A	5°			
	Backward tilt angle	A	10°	10°	6°	
	Lift cylinder drift (rated load) mm (in.)/15 min. [Oil temperature 45°C (113°F)]	A	50 (2.0), max		50 (2.0), max	40 (1.6), max
	Tilt cylinder drift (forward) (rated load) mm (in.)/15 min. [Oil temperature 45°C (113°F)]	A	22 (0.9)	20 (0.8)	20 (0.8)	15 (0.6)
Main relief valve setting kPa (kgf/cm <sup>2</sup> ) [psi]		A	18142 <sup>+490</sup> <sub>0</sub> (185 <sup>+5</sup> <sub>0</sub> ) [2631 <sup>+71</sup> <sub>0</sub> ]			
Steering system relief valve setting kPa (kgf/cm <sup>2</sup> ) [psi]		A	7845 (80) [1138]			
Hydraulic pump	Output liter (cu in.)/min.	A	64.8 (3954) at 2400 rpm	72 (4394) at 2400 rpm	79.2 (4833) at 2400 rpm	
Control valve	Tightening torque of tie bolts (M10, 1.25) N·m (kgf·m) [lbf·ft]	A	29.4 (3.0) [21.7]			

**Triplex Mast (3C15C, 3C25C and 3C30C)**

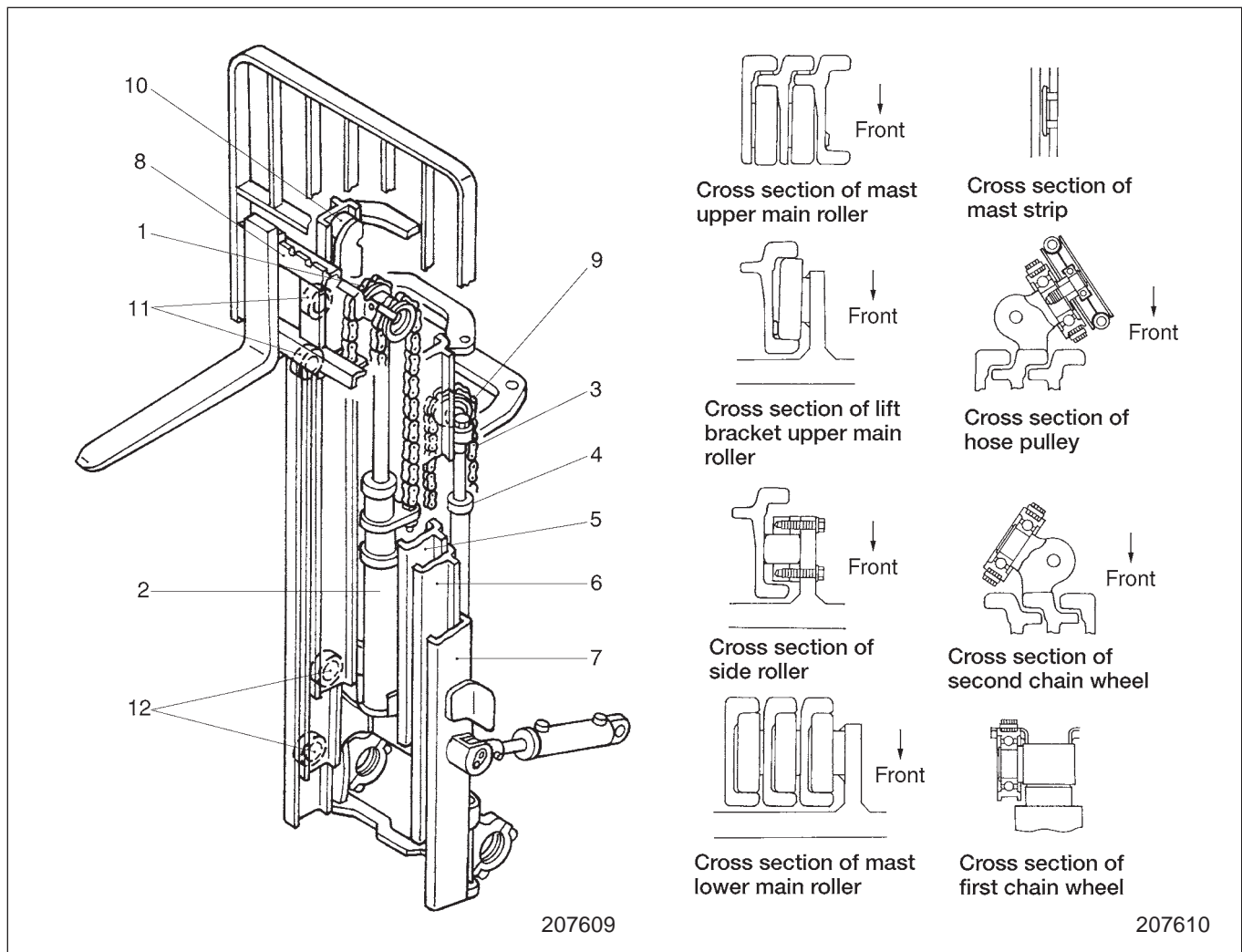

- |                        |                |                             |
|------------------------|----------------|-----------------------------|
| 1 First lift chain     | 5 Inner mast   | 9 Second chain wheel        |
| 2 First lift cylinder  | 6 Middle mast  | 10 Lift bracket main roller |
| 3 Second lift chain    | 7 Outer mast   | 11 Mast upper main roller   |
| 4 Second lift cylinder | 8 Lift bracket | 12 Mast lower main roller   |

The triplex mast provides a free lift amount until the top of lift bracket reaches the mast height.

The mast assembly consists of the inner mast, middle mast, outer mast, lift bracket, first lift cylinder and second lift cylinders.

The first lift cylinder raises the lift bracket, while the second cylinder operates the three-stage telescopic mechanism and lift bracket. Two pairs of lift chains are installed. The cylinders and lift chains are designed for smooth and effective operation.

For lifting operation, oil is first sent to the first lift cylinder which raises the forks until the cylinder rod reaches its stroke end.

When the first lift cylinder rod extends fully, the second lift cylinders raise the assembly consisting of the lift bracket, first lift cylinder, inner mast and middle mast.

The shoulder sections of the mast main rollers contact the mast rails. The rollers are installed perpendicular to the sliding surfaces.

The main rollers used in the triplex mast models are the same as those used in the simplex mast models.

## Duplex Mast

### Disassembly

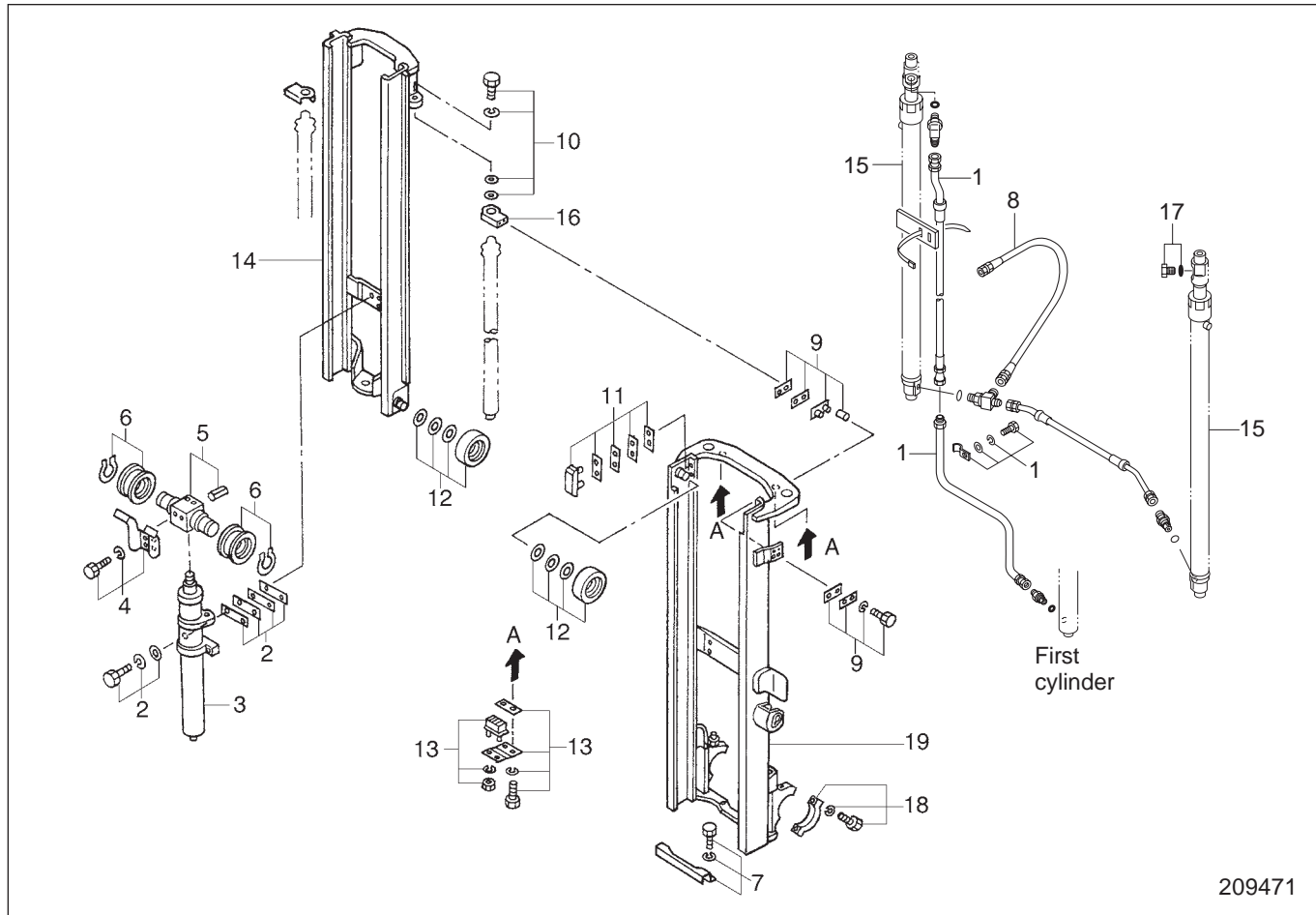

209471

### Sequence

- |  |  |
|--|--|
| 1 High-pressure hose for first cylinder, Clamp | 11 Mast strip, Shims                                   |
| 2 Bolt, Washer, Shims                          | 12 Main roller, Shims                                  |
| 3 First lift cylinder                          | 13 Stopper cushion, Cushion plate, Shims, Bolt, Washer |
| 4 Chain guard                                  | 14 Inner mast  |
| 5 Chain wheel support, Pin                     | 15 Second lift cylinder                                |
| 6 Chain wheel, Snap ring                       | 16 Cylinder bracket                                    |
| 7 Hose guard, Bolt, Washer                     | 17 O-ring, Plug  |
| 8 High-pressure hose                           | 18 Mast support cap, Bolt, Washer                      |
| 9 Cushion, Collar, Shims, Bolt, Washer, Clamp  | 19 Outer mast, Grease nipple                           |
| 10 Bolt, Washer, Shims                         |  |

### NOTE

The lift bracket disassembly procedure is the same as for the simplex mast.

**5. Installing first lift cylinder (duplex mast and triplex mast models)**

Adjust the position of the first lift cylinder with shims so that the first lift cylinder becomes vertical when it is installed and placed at the lowered position.

- Usually, a 2.0 mm (0.08 in.) thick shim is already used.
- The thickness of each shim is 1.0 mm (0.04 in.).
- Forward inclination is undesirable. It should be rather inclined rearward.

Tighten the mounting bolt after completing necessary adjustment using shims.

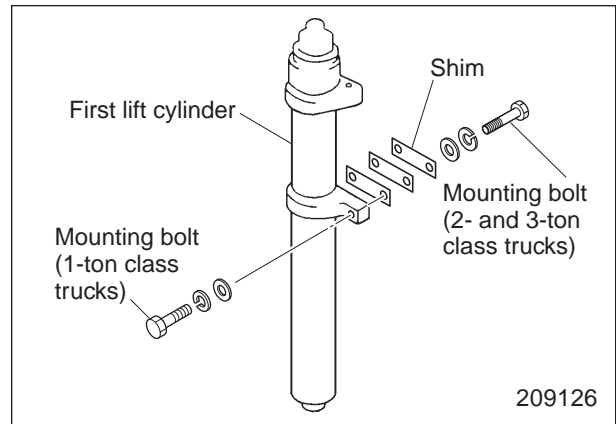

209126

**6. Installing chain on lift bracket (simplex mast model)**

Connect each chain to the lift bracket using the upper chain anchor kit assembled as shown in the illustration. The link plate 3 (with a stamped mark) should be on the side opposite to the link 1.

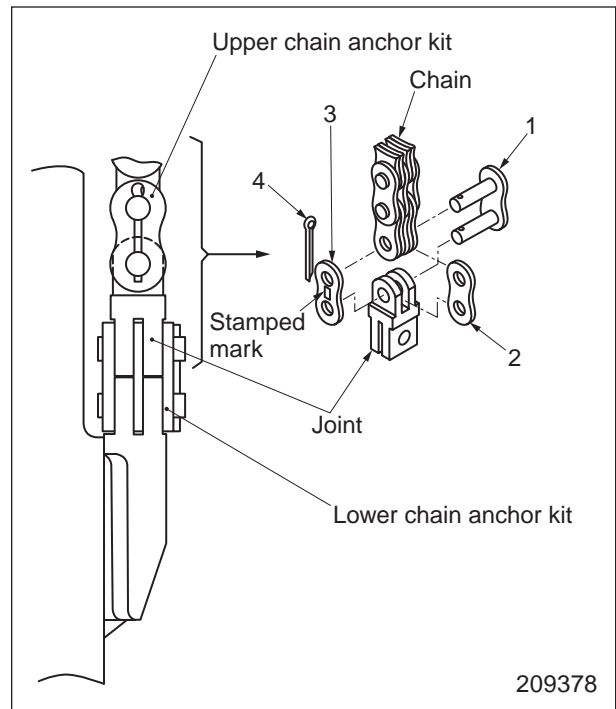

209378

- 1 Link
- 2 Center plate (without mark)
- 3 Link plate (with a stamped mark)
- 4 Split pin

Duplex Mast and Triplex Mast

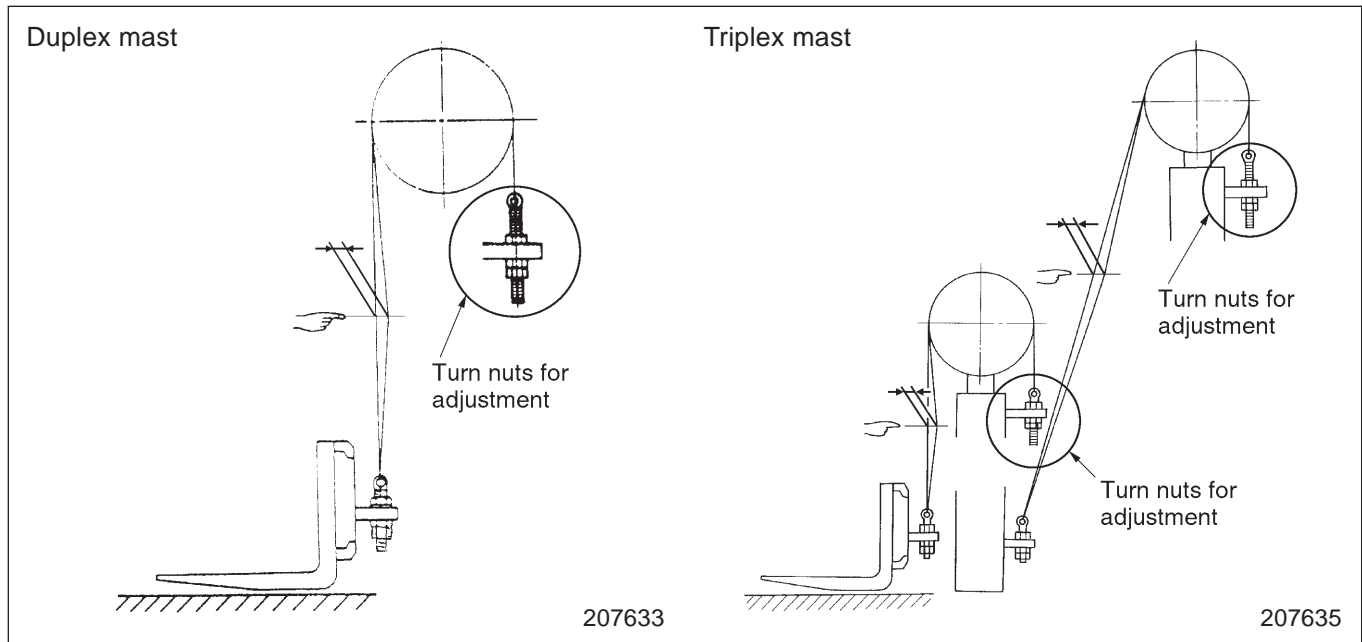

The inspection and adjustment procedures are completely the same as those for simplex mast models. Follow the procedures in the previous page to perform inspection or adjustment as necessary.

Chain, Chain Wheel Support and Chain Wheel

- (1) Check the right and left chains for uneven length, wear, adhesion or torsion.  
Lift the forks high enough to put their full weight on the carriage and chains.  
Check to be sure the lift chains have equal tension.
- (2) Check the chain anchor bolt for cracks or damaged thread.
- (3) Check the chain wheel support and the chain wheel for cracks, wear or adhesion.
- (4) Replace chain or chain anchor bolt. If new parts are installed, refer to "Installing chain on lift bracket" on page 12-24.

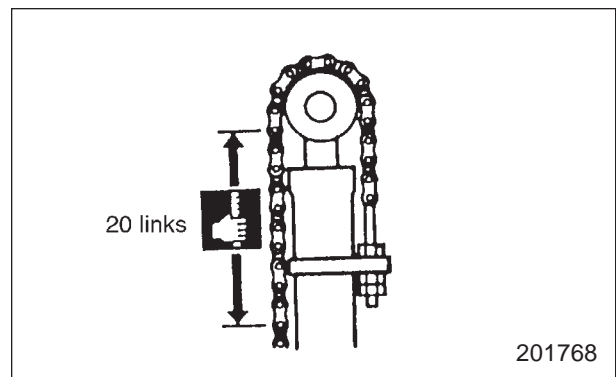

Length of lift chain (per 20 links)

A: Standard value    B: Repair or service limit  
Unit: mm (in.)

	GC15K GC18K	GC20K GC20K HP GC25K GC25K HP	GC30K
A	318 (12.52)	381 (15.00)	508 (20.00)
B	327 (12.87)	392 (15.43)	523 (20.59)

**NOTE**

To lubricate lift chains, molybdenum disulfide oil (spray type) is recommended since it is easy to use and provides long lubrication.

Super chain guard oil: 9101M-00150



### Planned Replacement Parts

The parts listed below are important for the safe working of the truck, and are specially designated as the parts to be replaced at specified periods. Each

service shop is requested to adhere to the replacement schedule given here on all trucks brought into its care:

Planned replacement parts		Service	Interval				
			1 month after delivery	1 month (200 hrs)	6 months (1200 hrs)	1 years (2400 hrs)	2 years (4800 hrs)
1	*Rubber parts for brake master cylinder	Replace				○	
2	*Rubber parts for brake wheel cylinder	Replace				○	
3	*Hydraulic hoses	Replace				○	
4	*Hoses for steering cylinder	Replace					○
5	*Rubber parts for steering cylinder	Replace					○
6	*Fuel hoses	Replace					○
7	*Lift chain	Replace					○
8	Fuel filter element	Replace	○		○		
9	Engine oil filter element	Replace	○	○			
10	Hydraulic tank return filter	Replace	○		○		
11	Air cleaner element	Clean	○				
		Replace			○		
12	Drum to lining clearance	Check or replace				○	
13	Engine timing belt	Check or replace				○	

Note: \*indicates important safety-related parts.

**Special Service Tools**

Ref. No.	Part number	Part name	Application	Truck models		
				GC15K GC18K	GC20K GC20K HP GC25K GC25K HP	GC30K
1	91268 - 00100	Wrench	Removal and installation of pulley (to be used with 91268 - 00200)	○	○	○
2	91268 - 00200	Wrench	Removal and installation of pulley	○	○	○
3	91268 - 00701	Socket wrench	Removal and installation of rear wheel nuts and counterweight bolts	○	○	○
4	67284 - 15400	Bolt	Removal of powershift transmission pump body	○	○	○
5	91268 - 04200	Installer	Installation of pump body oil seal	○	○	○
6	91268 - 00300 (or 91268 - 02100)	Bevel pinion puller	Removal of bevel pinion assembly	○	○	○
7	91268 - 04300	Installer	Installation of transmission output shaft oil seal	○	○	○
8	91268 - 13810 91268 - 13820 F1035 - 10020 T-24	Puller Plate Bolt Puller	Removal of powershift transmission bearing	○	○	○
9	91268 - 04100	Installer	Installation of powershift transmission ball bearings	○	○	○
10	91268 - 07100	Piston tool	Removal and installation of powershift transmission clutch return springs	○	○	○
11	91268 - 00500	Ring puller	Removal and installation of powershift transmission clutch spring	○	○	○
12	64309 - 17701	Gauge kit	Measurement of powershift transmission hydraulic pressure	○	○	○
13	91268 - 00400	Connector	Measurement of powershift transmission hydraulic pressure (to be used with 64309 - 17701)	○	○	○
14	91268 - 00800	Socket wrench	Removal and installation of front wheel hub nuts	○	○	○
15	03703 - 59001	Socket wrench	Removal and installation of front wheel hub nuts	○	–	–
16	91468 - 00300 64309 - 12300	Installer Installer	Installation of front axle wheel bearing inner races	– ○	○ –	○ –
17	91268 - 01500	Installer	Installation of rear axle inner bearing inner races	○	–	–
18	64309 - 40400	Installer	Installation of rear axle inner bearing inner races	–	○	○
19	91268 - 01400	Installer	Installation of rear axle outer bearing inner races	○	–	–

**SERVICE DATA**

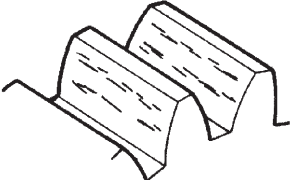
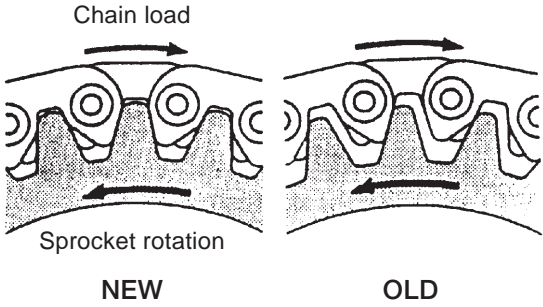
Check	For (item or defect)	How
Gears	i) Corrosive wear 	Visually.
Keys and keyways	Wear on sides making parts no fit tightly	Examine by placing.
Oil seals	Damage to lip	Visually.
Roller chains and sprockets	a) Wear on pins, bushing, rollers and plates in each link tending to increase pitch b) Wear on sprocket teeth 	Visually.
Rubber parts	Hardening or softening, swelling, tackiness, tearing, and deterioration due to aging	Visually.



CLICK HERE TO **DOWNLOAD** THE COMPLETE MANUAL

- Thank you very much for reading the preview of the manual.
- You can download the complete manual from: [www.heydownloads.com](http://www.heydownloads.com) by clicking the link below



- Please note: If there is no response to CLICKING the link, please download this PDF first and then click on it.

CLICK HERE TO **DOWNLOAD** THE COMPLETE MANUAL

### 3.1.2 Fixed liquid level gauge

Having No. 54 drill size orifice, this gauge is for the LP-gas tank having a dip tube welded in the tank. It is also used where the tank is mounted at the maximum allowable filling level.

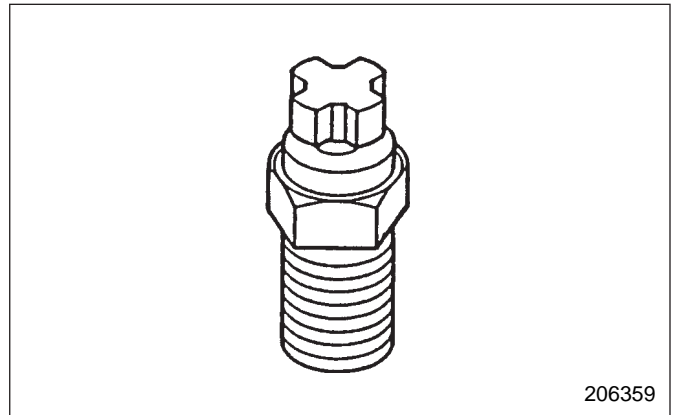

### 3.1.3 Service valve (LP-gas outlet valve)

The excess flow check valve located at the inlet consists of a spring, a valve disk complete with a stem, and a nozzle having a seat for the disk.

When the fuel flow rate is normal, the pressure acting on the face of the disk due to fuel velocity is not high, so that the spring keeps the disk pushed off the seat formed of the nozzle.

In the event of an excess flow rate caused, for instance, by failure of a hose connection, the pressure acting on the disk will be so high as to push in the disk against the force of the spring, thereby closing the nozzle to limit the flow of the fuel. This limiting action is due to the equalizing nozzle built in the disk.

The disk pushed against the nozzle will remain seated when a small amount of the fuel is flowing out through the equalizing nozzle but, as the pressure difference across the disk decreases and disappears, the spring will force the disk off to its normal lifted position.

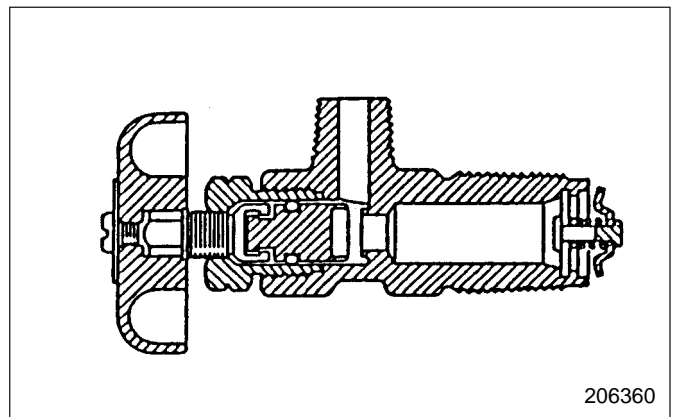

# PRE CARB DISASSEMBLY AND REASSEMBLY

## 1. Main components of LP-gas device (4G63, 4G64)

### Disassembly

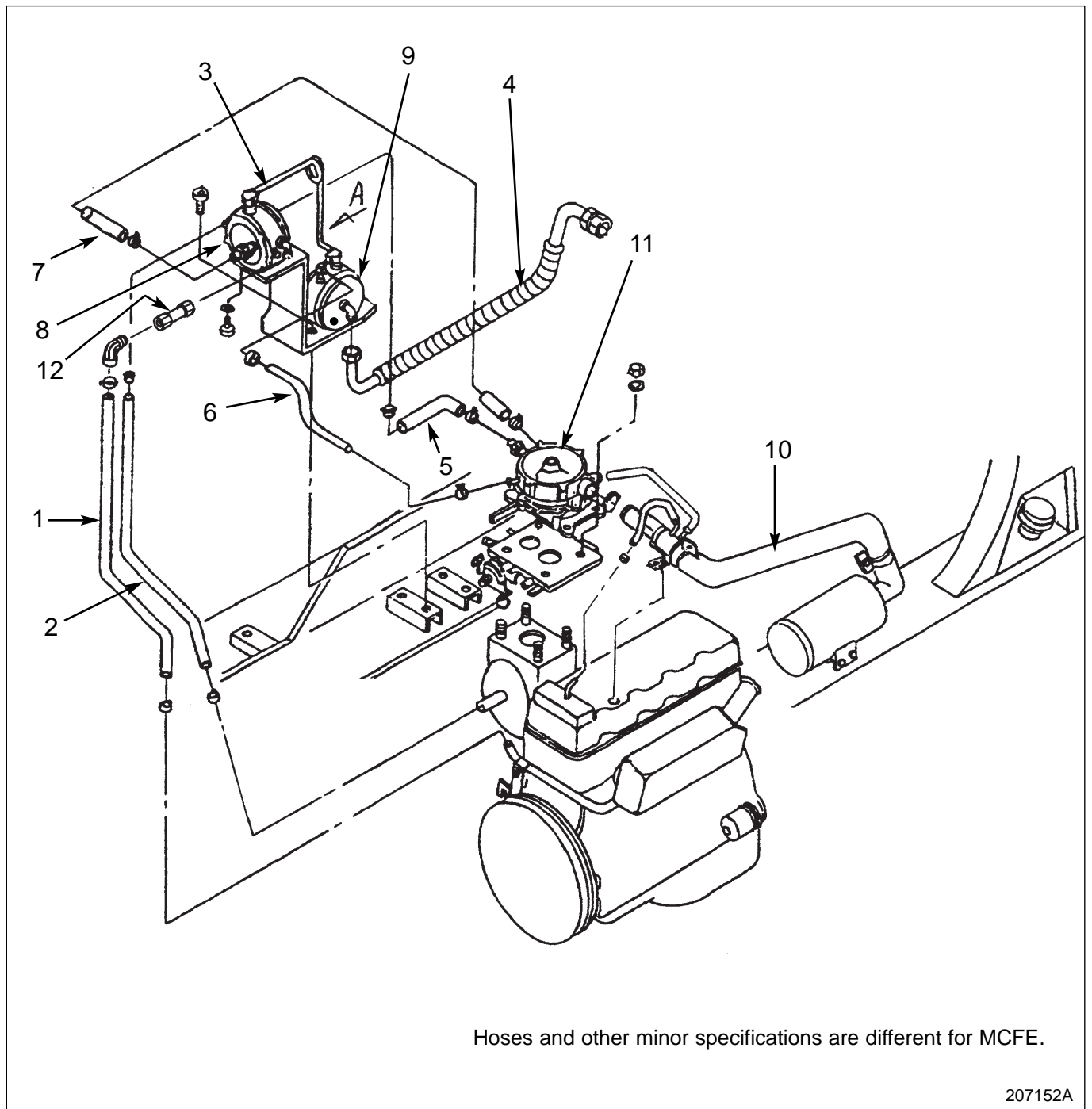

Hoses and other minor specifications are different for MCFE.

207152A

### Disassembly sequence

- |                  |                    |
|------------------|--------------------|
| 1 Hot-water hose | 7 Vacuum hose      |
| 2 Hot-water hose | 8 LP-gas converter |
| 3 Pipe           | 9 Filter           |
| 4 LP-gas hose    | 10 Air hose        |
| 5 LP-gas hose    | 11 Carburetor      |
| 6 Vacuum hose    | 12 Thermostat      |

5. Disassembly and reassembly of LP-gas filter, fuel lock (VFF30)



1. **DO NOT** use Teflon thread tape on any of the NPT pipe-thread fittings where fuel travels. Use a suitable fuel resistant joint compound.
2. Be sure to leak-check all fittings and covers for fuel tanks, using a soapy solution.
3. Be sure to use proper mounting bolts to secure the lockoff. Bolts which are too long may cause severe damage to the lockoff.

Disassembly

Disassembly sequence

- 1 Screw (10)
- 2 Filter cover
- 3 Gasket
- 4 Filter
- 5 Screen
- 6 Screw (1)
- 7 Valve spring
- 8 Valve seat
- 9 Valve operating pin
- 10 Retaining washer
- 11 O-ring lip seal
- 12 Screw (6)
- 13 Diaphragm cover
- 14 Diaphragm
- 15 Screw (2)
- 16 Fulcrum
- 17 Valve operating lever
- 18 Valve body

\* COMPONENTS INCLUDED IN THE REPAIR KIT.

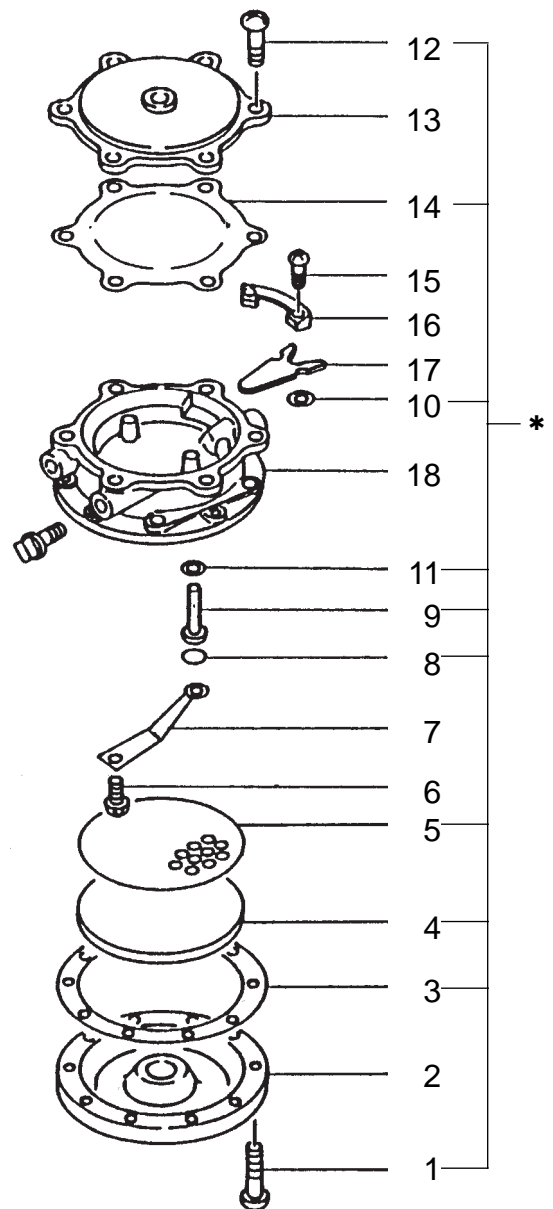

205399

# CARB Tier 1 Emissions Control System

The California Air Resources Board (CARB) is the state's environmental regulatory agency. CARB has issued emissions regulations for certain types of industrial equipment not already covered by existing EPA regulations. This new regulation impacts vehicles using "large spark-ignited" engines above 25 horsepower, including lift trucks. The term "sparkignited" includes all engines using gasoline, LP, and related fuel types, such as Compressed Natural Gas. The regulation applies only to new equipment, starting with units produced in year 2001, and does not require existing equipment to be modified to meet the new emissions standards.

The CARB regulations require lift truck manufacturers to modify a percentage of the trucks sold into California, beginning in year 2001, to incorporate an emissions control system (ECS) which will achieve exhaust emissions levels defined within the regulations. In the following years, the percentage of trucks sold with emissions reduction technology must increase each year until 2004, when the entire sparkignited engine line must be emissions compliant. This initial phase-in period is designated "Tier 1", and defines exhaust emissions standards which must be achieved by the manufacturer at the time of shipment. In 2004, "Tier 2" regulations will take effect, with a proposal by the EPA to adopt this as a nationally-legislated standard. The emissions standards and phase-in percentages are shown in the chart below.

	<b>Tier 1 CARB</b>	<b>Tier 2 CARB</b>
Effective Date	Jan 2001 to Dec 2003	Jan 2004 to Dec 2006
Emissions Limits (g/hp-hr)	CO 37 HC + NOx 3	37 3
Useful Life / Durability Testing Emissions Limits (g/hp-hr)	N/A	3500hr/5yr 50 CO 4 HC + NOx
Warranty Period- Components		
< \$400	1500hr / 2yr	2500hr / 3yr
> \$400	1500hr / 2yr	3500hr / 5yr
Phase-In %	2001 25% CA Sales 2002 50% CA Sales 2003 75% CA Sales	100% USA
Production Line Testing	Required	Required
In-Use Testing	N/A	Required
System Adjustment Tampering	Resistant	Tamper-Proof

## STRUCTURE AND FUNCTION

### Systems Operation

#### 1. Explanation of Operation

**4G63 (2.0 L.) & 4G64 (2.4 L.) LPG closed loop fuel control system with 3 way catalyst.**

#### **Regulatory Background:**

MCFA has developed an emissions-compliant control system. The control system is a closed-loop system with a 3-way catalytic converter as standard. It utilizes electronic fuel delivery with "drive-by-wire" throttle and governor control. The key system component is the Electronic Control Unit (ECU) that monitors various sensors on the truck, and controls engine performance to pre-programmed specifications. The two main sub-systems are:

- Fuel control
- Throttle and governor control

The benefit to the user is a vast improvement in indoor air quality, engine drivability and performance, maintenance and fuel economy.

#### 2. Terminology

Engine management systems use a variety of acronyms and system specific terms. The following list of terms and acronyms are used in the CARB 1 Tier 1 system. (Reference SAE J1330 terminology.)

A/F	Air Fuel Mixture
BAT	Battery Voltage
CAT	Catalytic Converter
ECU	Electric Control Unit
EGO	Exhaust Gas Oxygen Sensor
ET	Engine Temperature (Engine block temp.)
FCSV	Fuel Control Solenoid Valve
MAP	Manifold Absolute Pressure
OXY	Oxygen
RPM	Engine Revolutions per Min.
SFL	System Fault Light
SFC	System Fault Code

#### **Sub-system Operating Principles**

##### **1. Fuel Control:**

The fuel control system utilizes a "closed loop" fuel control strategy. The "Closed loop" method is used to calculate the correct air and fuel mixture ratio (A/F) based on ECU programming using data collected from sensor inputs while the engine is operating. This sub-system monitors four engine parameters and transmits this information to the ECU. The ECU is able to adjust the fuel supply by varying the output to the fuel control solenoid valve (FCSV). The inputs and output for this subsystem are as follows:

- 1) Engine manifold pressure (MAP) is an indicator of engine load. Higher loads result in a numerically higher MAP value.
- 2) Engine speed to indicate current engine revolutions per minute (RPM)

## SYSTEM ADJUSTMENTS

### 3.2 Diagnostic Screen Layout:

#### Diagnostic "D" Codes Screen

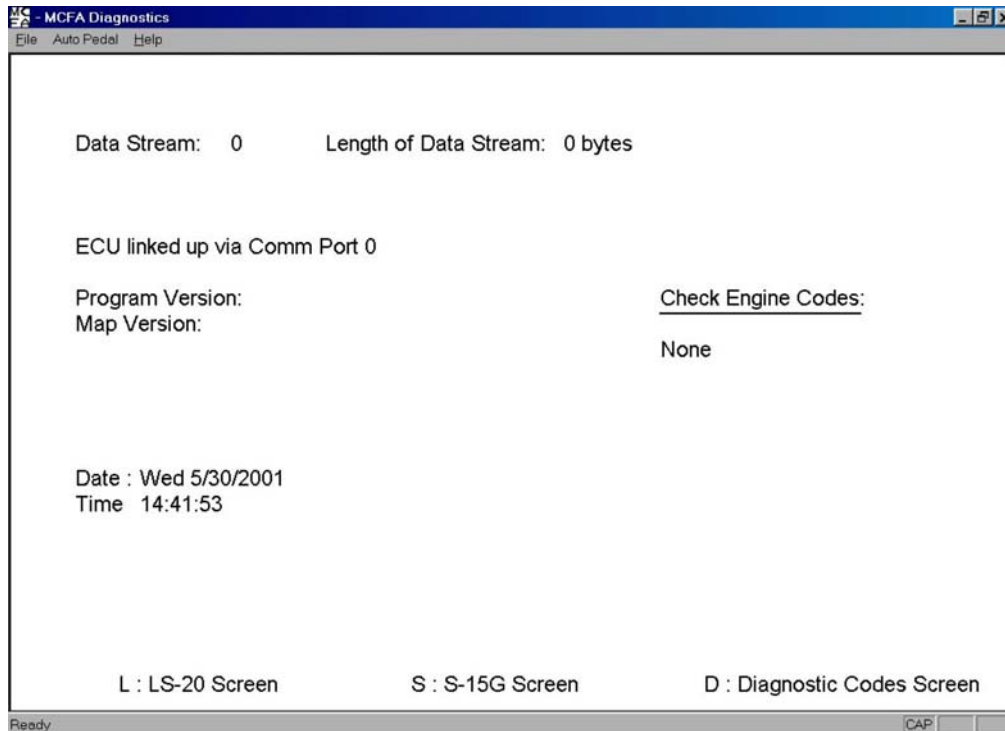

<b>Data Stream:</b>	Must be scrolling for proper connection to ECU
<b>Length of Data Stream:</b>	Typically 91 bytes
<b>Com Port:</b>	Shows Com Port selected from pull-down menu
<b>Program Version:</b>	Indicates EPROM installed in ECU
<b>Map Version:</b>	Indicates ECU calibration
<b>Check Engine Codes:</b>	<b>NONE</b> - No check engine codes <b>BAT</b> - Battery Voltage Error <b>CHRG</b> - Charging System Error <b>ETMP</b> - Engine Block Temperature Sensor Error <b>HTMP</b> - High Engine Block Temperature <b>KILL</b> - Emergency Engine Shutdown Activated <b>MAP</b> - Manifold Absolute Pressure signal Error <b>OXY</b> - Oxygen Sensor Error/Fuel System Error <b>THR</b> - Pedal Sensor out of Range/Open Circuit <b>TRIG</b> - TACH Signal Error

# SCHEMATICS

## 2. CARB 1 Tier 1 Wiring Schematic

### S15G SYSTEM

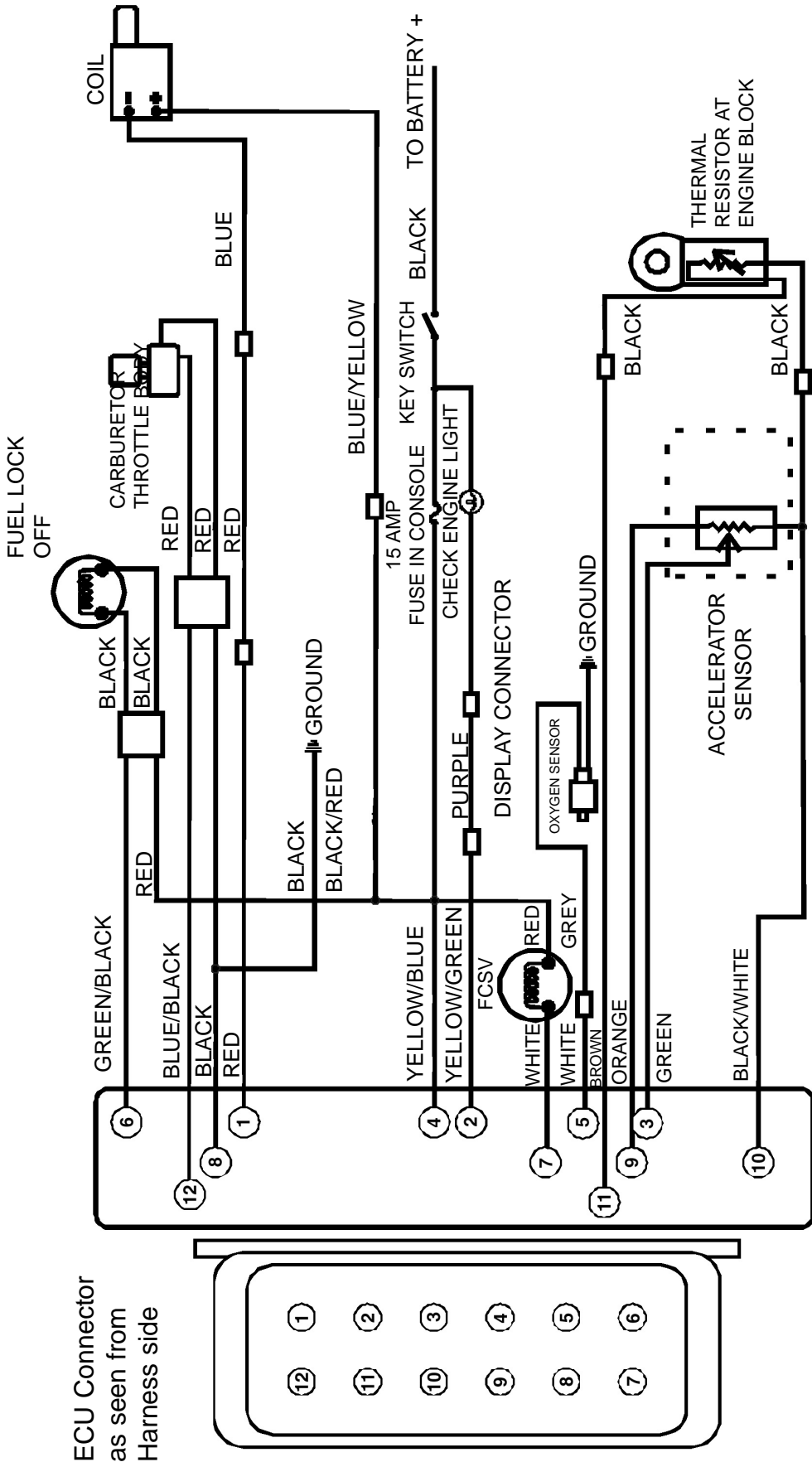

# TABLE OF CONTENTS

	Page
Engine RPM Sensor .....	.30
Engine Coolant Temperature Sensor (ECT) .....	.30
Closed Loop Control Schematic .....	.31
<b>LPG Fuel System Diagnostics</b> .....	
LPG Fuel System Diagnosis .....	.34
Fuel System Description .....	.34
Diagnostic Aids .....	.34
LPG Fuel System Diagnosis Chart .....	.35
<b>Symptom Diagnosis</b> .....	
Symptom Diagnosis .....	.42
Important Preliminary Checks .....	.42
Intermittent .....	.44
No Start .....	.46
Hard Start .....	.48
Cuts Out, Misses .....	.51
Hesitation .....	.53
Backfire .....	.54
Lack of Power, Sluggishness, or Sponginess .....	.56
Poor Fuel Economy .....	.58
Rough, Unstable, or Incorrect Idle, Stalling .....	.60
Surges, Chugs .....	.62
<b>Wiring Schematics</b> .....	
On-Vehicle Service Wire Harness Repair .....	.64
Connectors and Terminals .....	.64
Micro-Pack .....	.65
Metri-Pack .....	.65
Weather Pack .....	.65
Communication Port C002 .....	.71
Oil Pressure Connector C003 .....	.71
Heated Oxygen Sensor (HEGO) Connector C004 .....	.72
Fuel Trim Valve (FTV) Connector C005 .....	.72
TMAP Connector C006 .....	.73
Coil Connector C007 .....	.73
Magnetic Pickup Connector C008 .....	.74
Throttle Connector C009 .....	.74
Pressure Trim Valve (PTV) Connector C010 .....	.75
Starter Solenoid Connector C011 .....	.75
Engine Coolant Temperature Sensor (ECT) .....	.76
Battery Positive Connector C014 .....	.77
Battery Positive Connector C015 .....	.77
Alternator Connector C016 .....	.78
Alternator Connector C017 .....	.78
Instrument Panel Connector C018 .....	.79
Instrument Panel Connector C019 .....	.79

Particulates: Microscopic pieces of solid or liquid substances such as lead and carbon that are discharged into the atmosphere by internal combustion engines.

Positive Crankcase Ventilation (PCV): An automotive emission control system designed to reduce hydrocarbon emissions by routing crankcase fumes into the intake manifold rather than to the atmosphere.

Power Derate Level 1 ECM has detected condition in throttle control and limits throttle blade opening to 50%

Power Derate Level 2 ECM has detected condition in throttle control and limits throttle blade opening to 20%

Pressure Differential: The differential between atmospheric pressure and intake manifold (referred to as vacuum) pressure.

Pressure Regulator: A device to control the pressure of fuel delivered to the fuel injector(s).

Primary Circuit: The low-voltage or input side of the ignition coil.

Propane: An odorless, colorless gas,  $C_3H_8$ , found in natural gas and petroleum.

PTV: Pressure Trim Valve

Reactivity: Refers to the tendency of an HC in the presence of  $NO_x$  and sunlight to cause a smog-forming reaction. The lighter the HC, the lower reactivity tends to be.

Regulator: An assembly used to reduce and control the pressure of a liquid or vapor.

Resistance: The opposition to the flow of current in an electrical circuit. Measured in ohms.

## SECTION 1A1

# LPG FUEL SYSTEM OPERATION

<b>LPG Fuel System Operation</b> .....	
Typical LPG Fuel System Schematic .....	.22
Descriptions and Operation of the Fuel Systems .....	.23
Propane Fuel System .....	.23
LPG Fuel Tank .....	.23
Service Line .....	.23
Fuel Filter .....	.23
Electric Lock Off .....	.24
Low Pressure Regulator (LPR) .....	.24
Air Fuel Mixer .....	.25
Drive by Wire .....	.26
Three Way Catalytic Muffler .....	.27
Engine Control Module (ECM) .....	.28
Heated Exhaust Gas Oxygen Sensor .....	.28
Temperature Manifold Absolute Pressure Sensor (TMAP) .....	.30
Engine RPM Sensor .....	.30
Engine Coolant Temperature Sensor (ECT) .....	.30
Closed Loop Control Schematic .....	.31

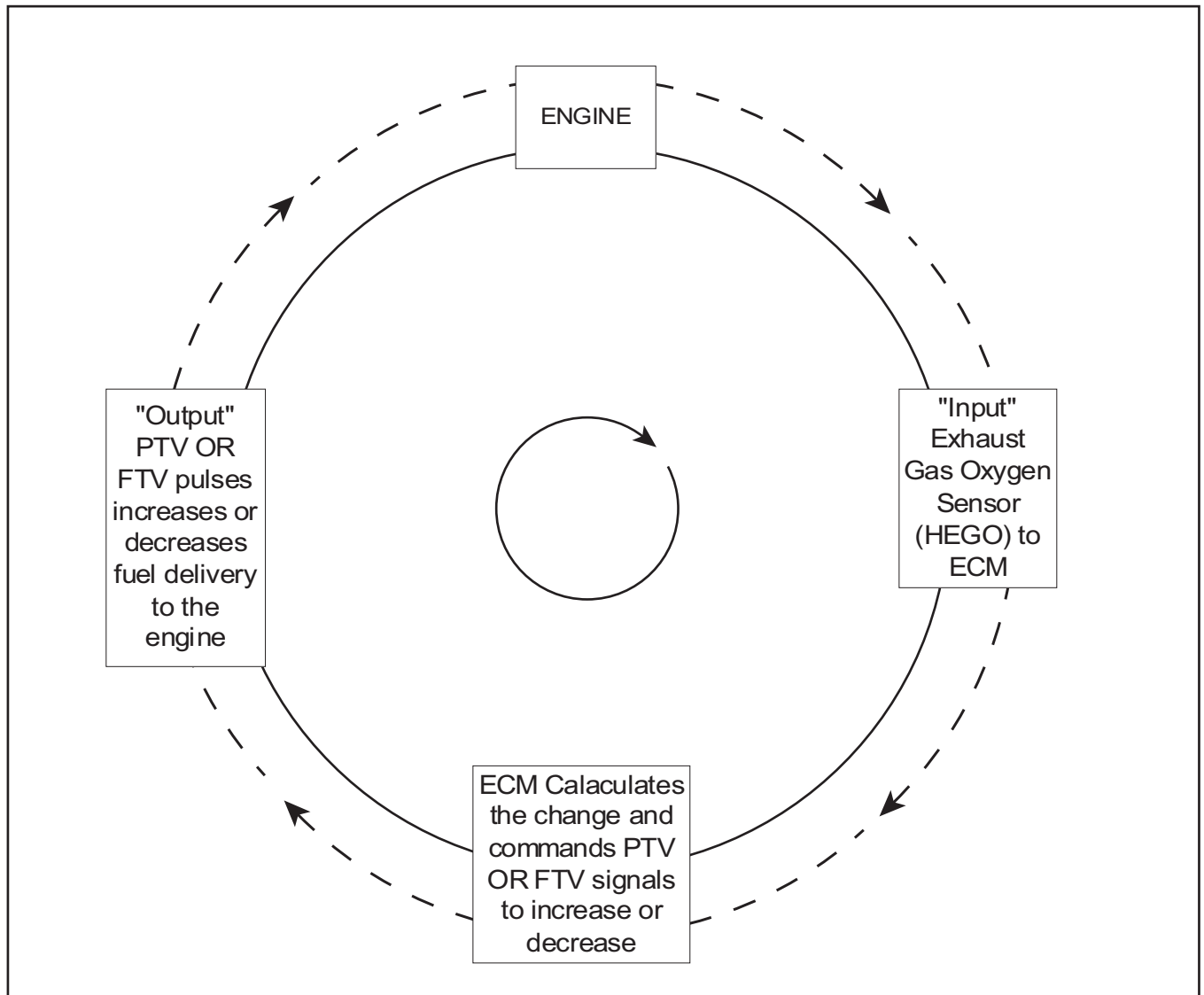

**Figure 15 Propane Closed Loop Control Schematic**

### **Closed Loop Control System**

Closed Loop control is the term used to describe the strategy used by the ECM to maintain proper tail pipe emission. The ECM utilizes the input of the sensors in the system to adjust air fuel ratio. The HEGO provides a signal to the ECM which indicates the amount of oxygen

present in the exhaust gases after combustion. The correct air fuel ratio is necessary to maintaining proper temperature in the catalyst for conversion of the unburned gases after combustion and supplying sufficient power for engine operation.

## Symptom Diagnosis

### Important Preliminary Checks

Checks	Action
Before Using This Section	<p>Before using this section, you should have performed On Board Diagnostic Check and determined that:</p> <ol style="list-style-type: none"> <li>1. The Control Module and MIL (Malfunction Indicator Lamp) are operating correctly.</li> <li>2. There are no Diagnostic Trouble Codes (DTCs) stored, or a DTC exists but without a MIL.</li> </ol> <p>Several of the following symptom procedures call for a careful visual and physical check. The visual and physical checks are very important. The checks can lead to correcting a problem without further checks that may save valuable time.</p>
LPG Fuel System Check	<ol style="list-style-type: none"> <li>1. Verify the customer complaint.</li> <li>2. Locate the correct symptom table.</li> <li>3. Check the items indicated under that symptom.</li> <li>4. Operate the vehicle under the conditions the symptom occurs. Verify HEGO switching between lean and rich.</li> </ol> <p><b>IMPORTANT!</b></p> <p><b>Normal HEGO switching indicates the LPG fuel system is in closed loop and operating correctly at that time.</b></p> <ol style="list-style-type: none"> <li>5. If a scan tool is available, <b>take a snapshot</b> under the condition that the symptom occurs. Go to <i>Engine Scan Tool Data List</i> to verify normal sensor values and parameters.</li> </ol>

Fuel System Checks	<ul style="list-style-type: none"> <li>• Check the fuel system - plugged fuel filter, low fuel pressure, etc. Refer to <i>LPG Fuel System Diagnosis</i>.</li> <li>• Check the condition of the wiring to the low pressure lock-off solenoid.</li> </ul>
Additional Check	<p>Check for Electromagnetic Interference (EMI).</p> <ul style="list-style-type: none"> <li>• EMI on the reference circuit can cause a missing condition.</li> <li>• Monitoring the engine RPM with a scan tool can detect an EMI.</li> <li>• A sudden increase in the RPM with little change in the actual engine RPM, indicates EMI is present.</li> <li>• If the problem exists, check the routing of the secondary wires and the ground circuit.</li> </ul>

## Surges/Chuggles

Checks	Action
DEFINITION: The engine has a power variation under a steady throttle or cruise. The vehicle feels as if it speeds up and slows down with no change in the accelerator pedal.	
Preliminary Checks	<ul style="list-style-type: none"> <li>• Refer to <i>Important Preliminary Checks</i>.</li> <li>• Be sure the driver understands the Torque Converter Clutch operation.</li> </ul>
Sensor Checks	Check the Heated Exhaust Gas Oxygen Sensor (HEGO) performance.
Fuel System Checks	<ul style="list-style-type: none"> <li>• Check for Rich or Lean symptom that causes the condition. Drive the vehicle at the speed of the complaint. Monitoring the oxygen sensors will help identify the problem.</li> <li>• Check the fuel pressure while the condition exists. Refer to <i>LPG Fuel System Diagnosis</i>.</li> <li>• Verify proper fuel control solenoid operation.</li> <li>• Verify that the LPG manual shut-off valve is fully open.</li> <li>• Check the in-line fuel filter for restrictions.</li> </ul>
Ignition System Checks	<ul style="list-style-type: none"> <li>• Check for the proper ignition output voltage using the spark tester or the equivalent.</li> <li>• Verify that the spark plugs are correct for use with LPG (R46TS)</li> <li>• Check the spark plugs. Remove the plugs and inspect them for the following conditions: <ul style="list-style-type: none"> <li>– Wet plugs</li> <li>– Cracks</li> <li>– Wear</li> <li>– Improper gap</li> <li>– Burned electrodes</li> </ul> </li> <li>– Heavy deposits</li> <li>– Check the Crankshaft Position (CKP) sensor.</li> </ul>
Additional Check	<ul style="list-style-type: none"> <li>• Check the ECM grounds for being clean, tight, and in their proper locations.</li> <li>• Check the generator output voltage.</li> <li>• Check the vacuum hoses for kinks or leaks.</li> <li>• Check Transmission</li> </ul>

### PRESSURE TRIM VALVE (PTV) CONNECTOR C010

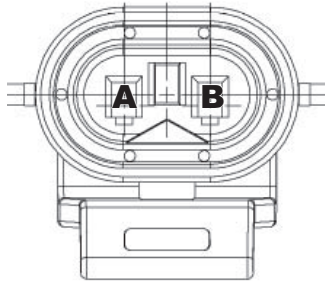

Pins	Wire Color	Function
A	White/Red	Gaseous Trim
B	Orange/Blue	INJ +

### STARTER SOLENOID CONNECTOR C011

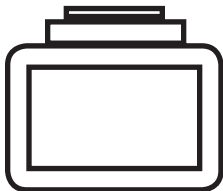

Pins	Wire Color	Function
A	White	Starter Relay R1

# DESCRIPTION OF ECM BASED DIAGNOSTICS

## DEFINITION OF TERMS

Active Gov Mode	Speed is governed by one of two modes. Isochronous, which maintains an exact speed, or Droop, which allows speed to drop a predetermined amount based on current engine load.
AL	Adaptive Learn
AL Mult	Adaptive Learn Multiplier. The adaptive learn multiplier is a correction to the fuel delivery which is expressed as a percentage (%) and stored in the ECM's RAM.
Analog	0 to 5 volt or 0 to 12 volt signals
Batt	Battery Voltage
BP	Barometric Pressure. The pressure of the outside air.
CHT	Cylinder Head Temperature
CL	Closed Loop
CL Mult	Closed Loop Multiplier. The closed loop multiplier is a fast acting adjustment to the fuel delivery based on feedback from the HEGO. The closed loop multiplier is expressed as a percentage (%) and is not stored in the ECM's memory.
Closed Loop	Fuel and timing modified based on feedback from the O2 sensor.
DBW	Drive by wire.
DTC	Diagnostic Trouble Code. A code which is stored in the ECM when an ECM initiated test fails.
ECT	Engine Coolant Temperature.
ECM	Engine Control Module. The computer, which controls the fuel and ignition system on the engine.
EGO	See HO2S
Forced Idle	ECM commands electronic throttle controller to an idle position.
FPP	Foot Pedal Position.
HO2S	Heated Oxygen Sensor
IAT	Intake Air Temperature
IVS	Idle Validation Switch
Low Rev Limit	Secondary engine speed control, only used to limit speed when throttle positioning is not maintaining desired speed
MAP	Manifold Absolute Pressure. The pressure of the air in the intake manifold.
MAT	Manifold Air Temperature. The temperature of the air in the intake manifold
MIL	Malfunction Indicator Light. A dash mounted light that illuminates when the ECM senses a system fault.
ms	Milli-seconds. 1/1000 of a second.
Open Loop	Fuel and timing based strictly on tables stored in the ECM.
Power Derate Level 1	ECM has detected condition in throttle control and limits throttle blade opening to 50%
Power Derate Level 2	ECM has detected condition in throttle control and limits throttle blade opening to 20%
PSIA	Pounds per square inch absolute. 14.7 psia = 0 psig
RAM	Random Access Memory. The portion of computer memory within the ECM, which changes as the engine is running and is stored while the engine is off.
TPS	Throttle Position Sensor. The throttle position sensor measures the opening of the throttle.

## OBD System Check/Malfunction Indicator Lamp

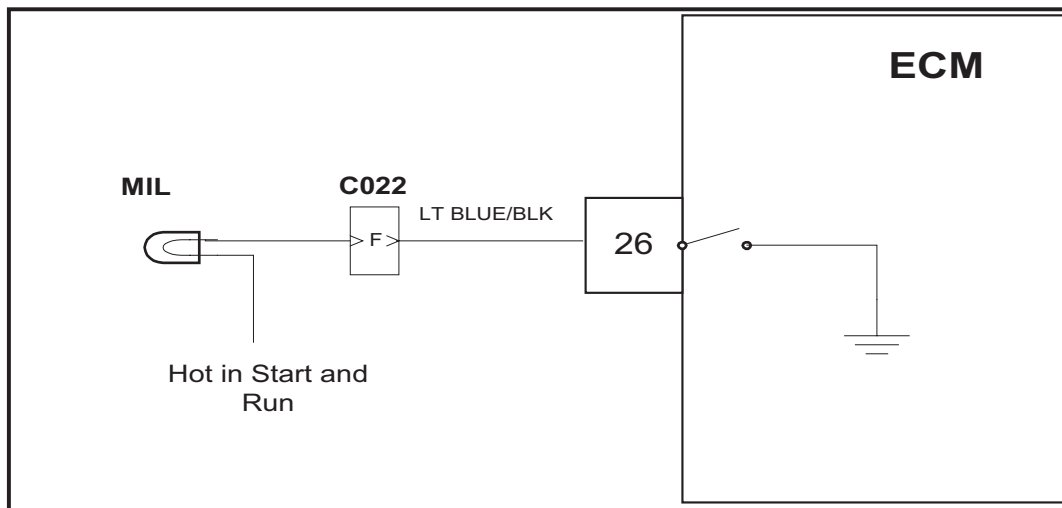

### Circuit Description

The fuel system is equipped with OBD (On-Board Diagnostics). The system has a dash mounted MIL (Malfunction Indicator Lamp) for the indication of system problems. Engine control system problems that affect emissions or driveability of the vehicle will set a DTC (Diagnostic Trouble Code). The ECM will then provide a path to ground and illuminate the MIL (Malfunction Indicator Lamp)

The MIL has the following functions:

1. It notifies the driver of a problem with the fuel system, ignition system, or emission control system so the driver can arrange for service as soon as possible.
2. It will display DTC's that have been stored due to a system malfunction.

The lamp should illuminate when the key is in the ON position, and the engine is not running. This feature verifies that the lamp is in proper working order. If the lamp does not come on with the vehicle key on/engine off, repair it as soon as possible. Once the engine is in start or run mode, the lamp should go off. If the lamp illuminates while the engine is in the start or run mode, a current Diagnostic Trouble Code may be set. Always use the OBD System Check chart on the next page of this manual to verify proper MIL operation before proceeding with a DTC diagnostic code repair.

# **DTC 113-IAT Higher Than Expected 1**

## **Diagnostic Aids**

\* This fault will set when inlet air is much hotter than normal. The most common cause of high inlet air temperature is a problem with the inlet air system. Ensure that the air inlet is not obstructed, modified or damaged.

\* Inspect the air inlet system for cracks or breaks that may allow unwanted under hood air in to the air inlet system

\* If none of the above can be found, Follow the diagnostic steps for DTC 112-IAT Low Voltage.

## DTC 122-ECT Low Voltage

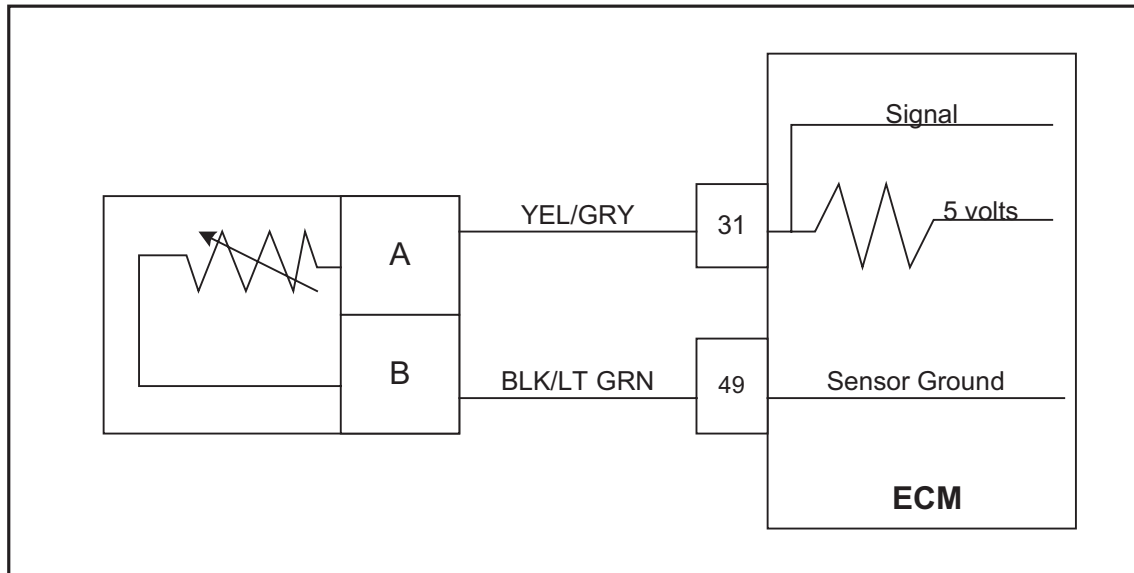

### Conditions for Setting the DTC

- Engine Coolant Temperature
- Check Condition-Engine Running
- Fault Condition- ECT sensor voltage less than 0.05
- MIL-On during active fault and for 2 seconds after active fault
- Adaptive-Disabled during active fault
- Closed Loop-Enabled

### Circuit Description

The ECT (Engine Coolant Temperature) sensor is a temperature sensitive resistor located in the engine coolant. It is used for the engine airflow calculation, gasoline cold enrichment and to enable other temperature dependant features. The ECM provides a voltage divider circuit so that when the coolant is cool, the signal reads higher voltage, and lower when warm

This fault will set if the signal voltage is less than 0.05 volts anytime the engine is running. The ECM will use a default value for the ECT sensor in the event of this fault.

## DTC 132-MAP Low Voltage

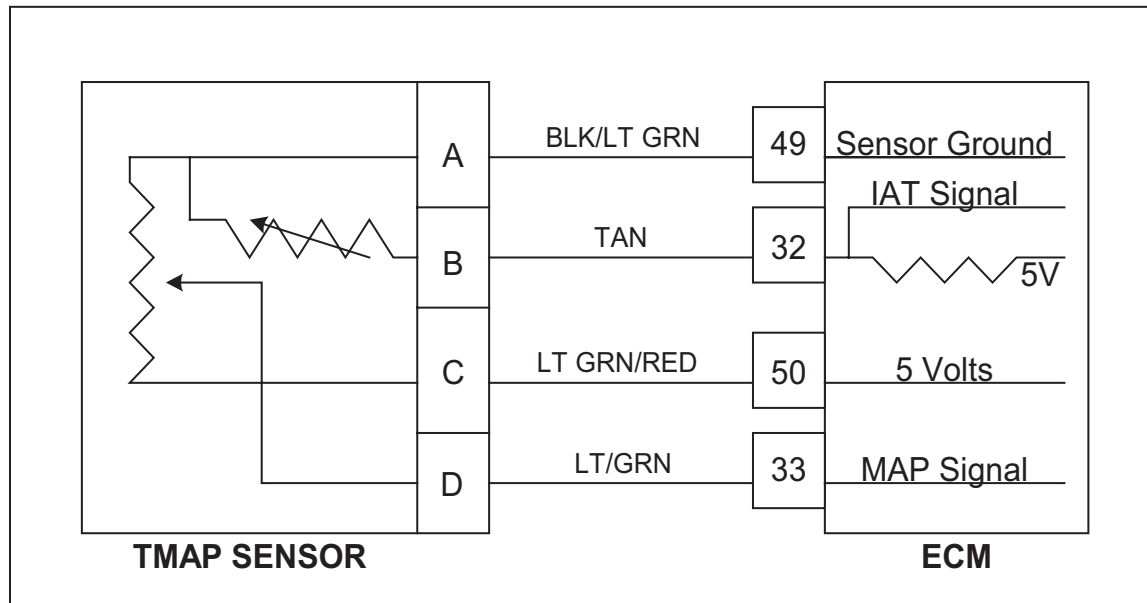

### Conditions for Setting the DTC

- Manifold Absolute Pressure
- Check Condition-Cranking or Running
- Fault Condition-MAP voltage less than 0.05, Throttle Position greater than 2% and engine RPM less than 7000.
- MIL-On
- Adaptive-Disabled for remainder of key on cycle
- Closed Loop-Enabled
- Misc.-Fueling is based on RPM and TPS Limp-Home Condition during this fault.

### Circuit Description

The Manifold Absolute Pressure sensor is a pressure transducer connected to the intake manifold. It is used to measure the pressure of air in the manifold prior to induction into the engine. The pressure reading is used in conjunction with other inputs to determine the airflow rate to the engine, which determines the fuel flow rate. This fault will set when the MAP reading is lower than the sensor should normally produce. When this fault is set the Adaptive Learn will be disabled for the remainder of the key on cycle and the MIL will be on.

18	<ul style="list-style-type: none"> <li>• Remove all test equipment except the DST.</li> <li>• Connect any disconnected components, fuses, etc.</li> <li>• Using the DST clear DTC information from the ECM.</li> <li>• Turn the ignition OFF and wait 30 seconds.</li> <li>• Start the engine and operate the vehicle to full operating temperature</li> <li>• Observe the MIL</li> <li>• Observe engine performance and driveability</li> <li>• After operating the engine within the test parameters of DTC-135 check for any stored codes.</li> </ul> <p>Does the engine operate normally with no stored codes?</p>		System OK	Go to OBD System Check
----	--	--	-----------	------------------------

V

### DTC 211- Closed Loop Multiplier High (LPG)

Step	Action	Value(s)	Yes	No
1	Did you perform the On-Board (OBD) System Check?	-	Go to Step (2)	Go to OBD System Check Section
2	<ul style="list-style-type: none"> <li>• Key On, Engine Running</li> <li>• DST (Diagnostic Scan Tool) connected in System Data Mode</li> <li>• Run engine to full operating temperature and then idle for a minimum of 2 minutes</li> </ul> Does DST display HO2S voltage fixed below 0.35 volts after 2 minutes of idle run time?		Go to step (3)	Intermittent problem Go to Intermittent section
3	<ul style="list-style-type: none"> <li>• Key OFF</li> <li>• Disconnect ECM connector</li> <li>• Disconnect HO2S wire harness connector</li> <li>• Using a high impedance DVOM check for continuity between HO2S connector signal pin B and engine ground</li> </ul> Do you have continuity?		Repair the circuit as necessary. Refer to Wiring Repairs in Engine Electrical.	Go to Step (4)
4	<ul style="list-style-type: none"> <li>• Using a high impedance DVOM check for continuity between HO2S connector signal pin B and HO2S connector sensor ground pin A</li> <li>• Do you have continuity between them?</li> </ul>		Repair the circuit as necessary. Refer to Wiring Repairs in Engine Electrical.	Go to Step (5)
5	<ul style="list-style-type: none"> <li>• Refer to Diagnostic aids for DTC 211</li> </ul> Did you check the diagnostic Aids for DTC 211?		Go to Step (6)	
6	<ul style="list-style-type: none"> <li>• Replace HO2S sensor</li> </ul> Is the replacement complete?		Go to Step (7)	

## DTC 244-Adaptive Learn Low (LPG)

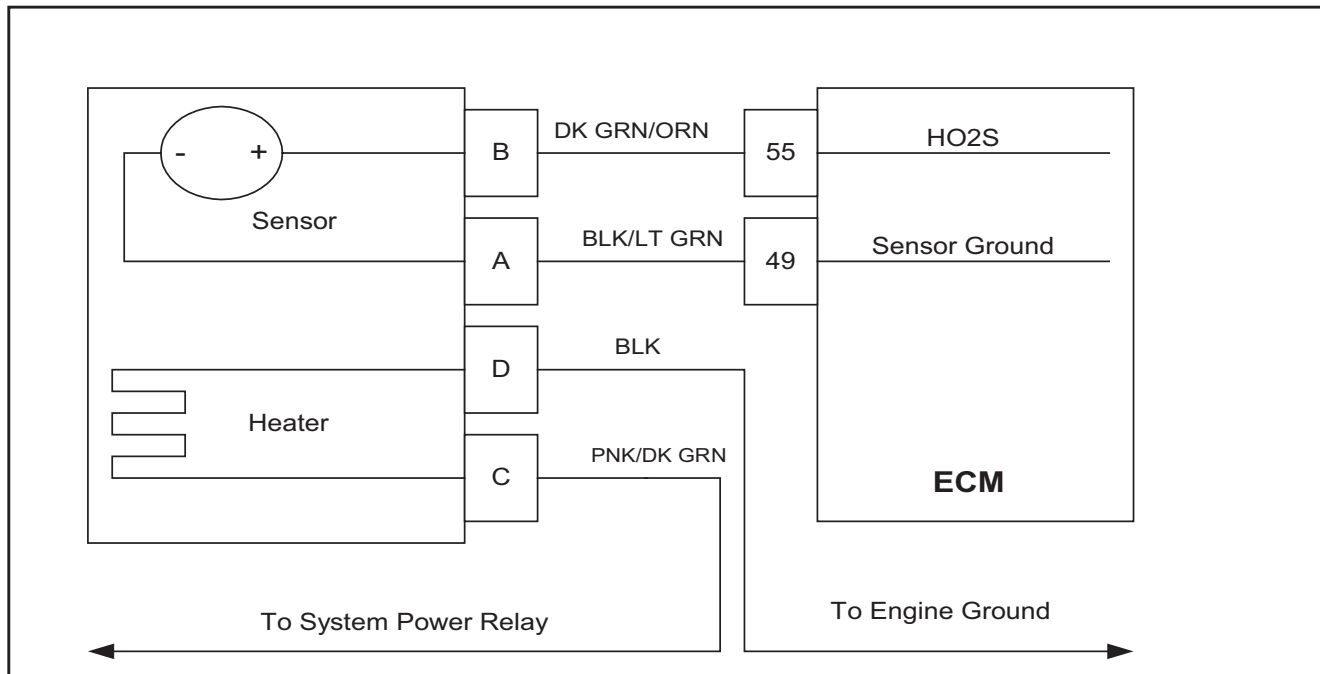

### Conditions for Setting the DTC

- Heated Oxygen Sensor
- Check Condition- Engine running
- Fault Condition- Adaptive multiplier out of range (at limit of -30%)
- MIL-Disabled
- Adaptive- Enabled
- Closed Loop- Enabled

### Circuit Description

The HO2S sensor is used to determine if the fuel flow to the engine is correct by measuring the oxygen content in the exhaust gas. The ECM uses this information to correct the fuel flow with the Closed Loop multiplier and Adaptive multiplier. This fault will set if the adaptive multiplier exceeds the limits of normal operation.

### Diagnostic Aids

Always diagnose any other ECM codes that are present before beginning this diagnostic procedure.

Fuel System High secondary fuel pressure will cause the system to run rich. A worn fuel mixer, faulty PTV (pressure trim valve) or FTV (fuel trim valve) can also cause the system to run rich.

Fuel Quality A drastic variation in fuel quality (very high butane content) may cause the system to run rich. Be sure that the specified HD-5 or HD-10 motor fuel grade propane is used.

## DTC 512-Invalid Interrupt

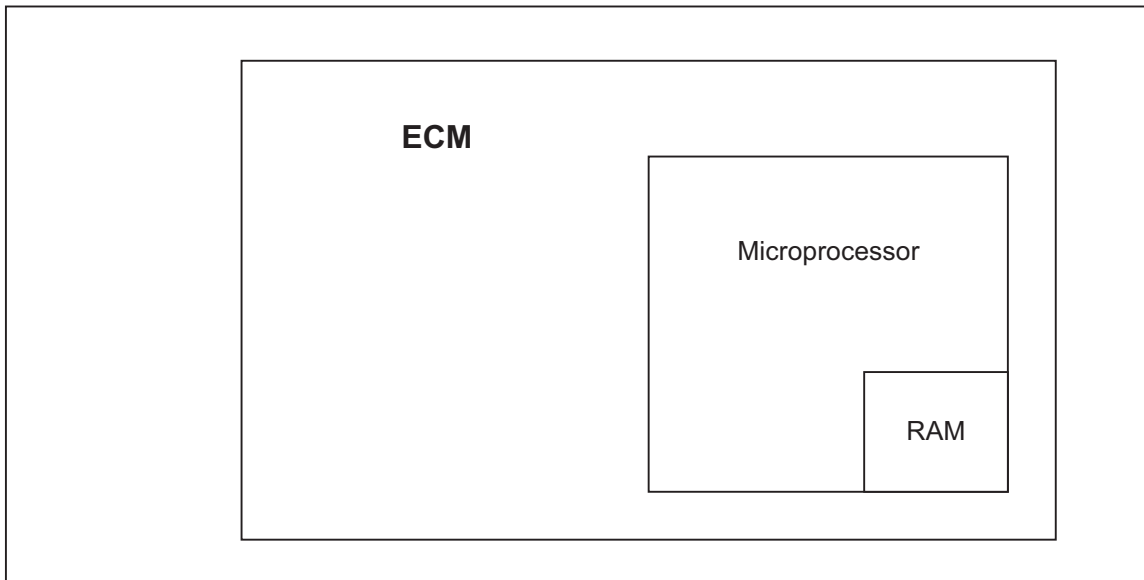

### Conditions for Setting the DTC

- Engine Control Module
- Check Condition- Key on
- Fault Condition- Internal microprocessor error
- MIL- On until code is cleared by technician
- Adaptive- Disabled for the remainder of the key-on cycle
- Closed Loop- Enabled
- Power Derate (level 2 until fault is cleared manually)

### Circuit Description

The ECM has checks that must be verified each time an instruction is executed. Several different things can happen within the microprocessor that will cause this fault. The ECM will reset itself in the event this fault is set, and the MIL will be on until the code is cleared. This fault should be erased after diagnosis by removing battery power. It will not self-erase.

During this active fault, Power Derate (level 2) will be enforced. When this is enforced, maximum throttle position will be 20%. This is enforced until the fault is manually cleared.

## DTC 531-External 5V Ref Lower Than Expected

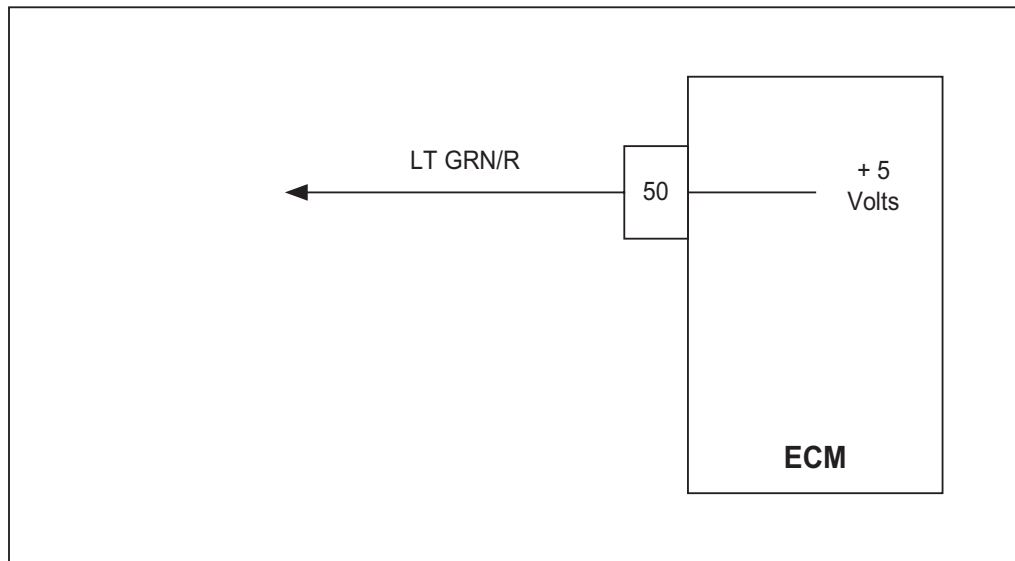

### Conditions for Setting the DTC

- External 5V reference
- Check Condition-Cranking with battery voltage greater than 8 volts and engine running
- Fault Condition-5V reference voltage lower than 4.6 volts
- MIL-On during active fault and for 2 seconds after active fault
- Adaptive-Disabled during active fault
- Closed Loop-Enabled

### Circuit Description

The External 5 Volt supply powers some of the sensors and other components in the system. The accuracy of the 5 Volt supply is very important to the accuracy of the sensors and therefore controlled by the ECM. The ECM monitors the 5 volt supply to determine if it is overloaded, shorted, or otherwise out of specification. This fault will set if the 5 Volt reference is below 4.6 volts.

### DTC 556 RTI 3 Loss

Step	Action	Value(s)	Yes	No
1	Did you perform the On-Board (OBD) System Check?	-	Go to Step (2)	Go to OBD System Check Section
2	<ul style="list-style-type: none"> <li>• Key On, Engine Running</li> <li>• DST (Diagnostic Scan Tool) connected in System Data Mode</li> <li>• Clear system fault code</li> </ul> Does DTC 555 reset with the engine idling?		Go to Step (3)	Intermittent problem Go to Intermittent section
3	<ul style="list-style-type: none"> <li>• Check all ECM power and ground circuits. Refer to power and ground distribution in engine electrical section.</li> </ul> Are the power and ground circuits Ok?		Go to Step (4)	Repair the circuit as necessary. Refer to Wiring Repairs in Engine Electrical.
4	<ul style="list-style-type: none"> <li>• Replace ECM</li> </ul> Is the replacement complete?		Go to Step (5)	-
5	<ul style="list-style-type: none"> <li>• Remove all test equipment except the DST.</li> <li>• Connect any disconnected components, fuses, etc.</li> <li>• Using the DST clear DTC information from the ECM.</li> <li>• Turn the ignition OFF and wait 30 seconds.</li> <li>• Start the engine and operate the vehicle to full operating temperature</li> <li>• Observe the MIL</li> <li>• Observe engine performance and driveability</li> <li>• After operating the engine within the test parameters of DTC-556 check for any stored codes.</li> </ul> Does the engine operate normally with no stored codes?		System OK	Go to OBD System Check

### DTC 613 FPP Higher Than IVS Limit

Step	Action	Value(s)	Yes	No
1	Did you perform the On-Board (OBD) System Check?	-	Go to Step (2)	Go to OBD System Check Section
2	<ul style="list-style-type: none"> <li>• Key ON, Engine OFF</li> <li>• DST (Diagnostic Scan Tool) connected in System Data Mode</li> </ul> Does the DST display IVS "idle" with the foot pedal fully depressed?		Go to Step (3)	Go to Step (7)
3	<ul style="list-style-type: none"> <li>• Key OFF</li> <li>• Disconnect foot pedal from harness</li> <li>• Key ON</li> </ul> Does DST display IVS "idle"?		Go to Step (4)	Go to Step (5)
4	<ul style="list-style-type: none"> <li>• Replace foot pedal</li> </ul> Is the replacement complete?		Go to Step (8)	-
5	<ul style="list-style-type: none"> <li>• Key OFF</li> <li>• Disconnect ECM wire harness connector</li> <li>• Using a DVOM check for continuity between IVS signal and engine ground</li> </ul> Do you have continuity between them?		Repair the circuit as necessary. Refer to Wiring Repairs in Engine Electrical.	Go to Step (6)
6	<ul style="list-style-type: none"> <li>• Replace ECM</li> </ul> Is the replacement complete?		Go to Step (8)	-
7	<ul style="list-style-type: none"> <li>• Depress foot pedal until DST reads FPP voltage between 1.1 and 1.3 volts</li> </ul> Does DST display IVS "idle"	1.1 to 1.3 volts	Go to Step (4)	Intermittent problem Go to Intermittent section
8	<ul style="list-style-type: none"> <li>• Remove all test equipment except the DST.</li> <li>• Connect any disconnected components, fuses, etc.</li> <li>• Using the DST clear DTC information from the ECM.</li> <li>• Turn the ignition OFF and wait 30 seconds.</li> <li>• Start the engine and operate the vehicle to full operating temperature</li> <li>• Observe the MIL</li> <li>• Observe engine performance and driveability</li> <li>• After operating the engine within the test parameters of DTC-613 check for any stored codes.</li> </ul> Does the engine operate normally with no stored codes?		System OK	Go OBD System Check

### DTC 633 TPS 2 Signal Voltage High

Step	Action	Value(s)	Yes	No
1	Did you perform the On-Board (OBD) System Check?	-	Go to Step (2)	Go to OBD System Check Section
2	<ul style="list-style-type: none"> <li>• Key ON, Engine OFF</li> <li>• DST (Diagnostic Scan Tool) connected in DBW (Drive by Wire) throttle test mode</li> </ul> Does the DST display TPS 2 voltage of 4.8 volts or greater with the throttle closed		Go to Step (4)	Go to Step (3)
3	<ul style="list-style-type: none"> <li>• Slowly depress Foot Pedal while observing TPS 2 voltage</li> </ul> Does TPS 2 voltage ever exceed 4.8 volts?		Go to Step (4)	Intermittent problem Go to Intermittent section
4	<ul style="list-style-type: none"> <li>• Key OFF</li> <li>• Disconnect electronic throttle connector</li> <li>• Key ON</li> </ul> Does DST display TPS 2 voltage less than 0.2 volts?		Go to Step (7)	Go to Step (5)
5	<ul style="list-style-type: none"> <li>• Key OFF</li> <li>• Disconnect ECM wire harness connector C001</li> <li>• Key ON</li> <li>• Using a DVOM check for voltage between electronic throttle connector TPS 2 signal pin 5 and engine ground</li> </ul> Do you have voltage?		Repair the circuit as necessary. Refer to Wiring Repairs in Engine Electrical.	Go to Step (6)
6	<ul style="list-style-type: none"> <li>• Replace ECM</li> </ul> Is the replacement complete?		Go to Step (11)	-
7	<ul style="list-style-type: none"> <li>• Back probe sensor ground circuit at the ECM side of the wire harness pin 49 with a test light connected to battery voltage</li> </ul> Does the test light come on?		Go to Step (8)	Go to Step (10)
8	<ul style="list-style-type: none"> <li>• Inspect the electronic throttle wire harness connector and terminals for damage, corrosion or contamination</li> </ul> Did you find a problem?		Repair the circuit as necessary. Refer to Wiring Repairs in Engine Electrical.	Go to Step (9)

### DTC 636 TPS 1 Lower Than TPS 2

Step	Action	Value(s)	Yes	No
1	Did you perform the On-Board (OBD) System Check?	-	Go to Step (2)	Go to OBD System Check Section
2	<ul style="list-style-type: none"> <li>• Key ON, Engine OFF</li> <li>• DST (Diagnostic Scan Tool) connected in System Data Mode</li> </ul> Does the DST display more than a 20% difference between TPS 1 and TPS 2?		Go to Step (3)	Intermittent problem Go to Intermittent section
3	<ul style="list-style-type: none"> <li>• Key OFF</li> <li>• Disconnect wiring harness connector to throttle</li> <li>• Key ON</li> <li>• Change DST mode to DBW (drive by wire) test mode</li> </ul> Is the voltage for TPS 1 and TPS 2 less than 0.1 volts?		Go to Step (5)	Go to Step (4)
4	<ul style="list-style-type: none"> <li>• Key OFF</li> <li>• Disconnect ECM wiring harness connector</li> <li>• Key ON</li> <li>• Using a DVOM check for voltage between TPS 1 or TPS 2 (the one that is over 0.1 volts) and engine ground</li> </ul> Do you have voltage?		Repair the TPS 1 or TPS 2 circuit as necessary. Refer to Wiring Repairs in Engine Electrical.	Go to Step (13)
5	<ul style="list-style-type: none"> <li>• Jumper TPS 1 and TPS 2 signal to the 5 volt reference at the throttle connector</li> </ul> Does DST display TPS 1 and TPS 2 voltage over 4.95 volts		Go to Step (6)	Go to Step (8)
6	<ul style="list-style-type: none"> <li>• Inspect wire terminals at throttle connector for damage corrosion or contamination</li> </ul> Any problems found?		Repair the circuit as necessary. Refer to Wiring Repairs in Engine Electrical.	Go to Step (7)
7	<ul style="list-style-type: none"> <li>• Replace Throttle</li> </ul> Is the replacement complete?		Go to Step (14)	-

### DTC 651 Max Govern Speed Override

Step	Action	Value(s)	Yes	No
1	Did you perform the On-Board (OBD) System Check?	-	Go to Step (2)	Go to OBD System Check Section
2	<ul style="list-style-type: none"> <li>• Key ON, Engine OFF</li> <li>• DST in Active Fault Mode</li> </ul> Are any other DTC codes present with DTC 651?		Go to Step (3)	Go to Step (4)
3	<ul style="list-style-type: none"> <li>• Diagnose any other DTC codes before proceeding with this chart.</li> </ul> Have any other DTC codes been diagnosed and repaired?		Go to step (4)	-
4	<ul style="list-style-type: none"> <li>• Check the Service Part Number on the ECM to ensure correct calibration is in use</li> </ul> Is the Service Part Number Correct?		Go to Step (6)	Go to Step 5
5	<ul style="list-style-type: none"> <li>• Replace ECM with correct Service Part Number</li> </ul> Is the replacement complete?		Go to Step (9)	-
6	<ul style="list-style-type: none"> <li>• Check the mechanical operation of the throttle</li> </ul> Is the mechanical operation of the throttle OK?		Go to Step (8)	Go to Step (7)
7	<ul style="list-style-type: none"> <li>• Correct mechanical operation of the throttle. Refer to Engine &amp; Component R&amp;R Section 1E</li> </ul> Has the mechanical operation of the throttle been corrected?		Go to step (9)	-
8	<ul style="list-style-type: none"> <li>• Check engine for large manifold vacuum leaks. Refer to Fuel Systems Section 1B Symptom Diagnostics</li> </ul> Did you find and correct the vacuum leak?		Go to Step (9)	Go to OBD System Check Section

## REPAIR INSTRUCTIONS

### PROPANE FUEL SYSTEM PRESSURE RELIEF

#### **⚠ WARNING**

The propane fuel system operates at pressures up to 21.5 BAR (312 psi). To minimize the risk of fire and personal injury, relieve the propane fuel system pressure (where applicable) before servicing the propane fuel system components.

To relieve propane fuel system pressure:

1. Close the manual shut-off valve (MSV) on the propane fuel tank.
2. Start and run the vehicle until the engine stalls.
3. Turn the ignition switch OFF.

#### **⚠ WARNING**

Residual vapor pressure will be present in the fuel system. Ensure the work area is well ventilated before disconnecting any fuel line.

### PROPANE FUEL SYSTEM LEAK TEST

#### **⚠ WARNING**

Never use an open flame of any type to check for propane fuel system leaks.

Always inspect the propane fuel system for leaks after performing service. Check for leaks at the fittings of the serviced or replaced component. Use a commercially available liquid leak detector or an electronic leak detector. When using both methods, use the electronic leak detector first to avoid contamination by the liquid leak detector.

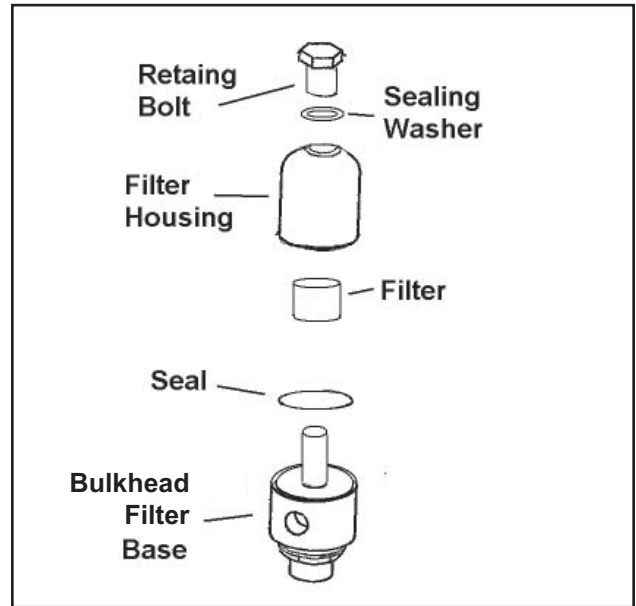

**Figure 1 Fuel Filter**

### PROPANE FUEL FILTER REPLACEMENT (Figure 1)

#### Removal Procedure

1. Relieve the propane fuel system pressure. Refer to Propane Fuel System Pressure Relief.
2. Disconnect the negative battery cable.
3. Slowly loosen the fuel inlet hose fitting to relieve any residual fuel pressure.
4. Remove the filter housing retaining bolt and sealing washer. Discard washer.
5. Remove the filter housing from the bulkhead filter base. Discard the filter and the sealing ring.
6. Clean and inspect the filter base for any debris.

#### Installation Procedure

#### **NOTE**

Be sure to install new sealing washer and seals. Do Not use Teflon tape on the pipe fittings; use only a liquid pipe sealant.

7. Install the housing seal to the bulkhead base.

hold the tool in place if necessary. Center the timing wheel to the pulley.

- Timing wheel should have very little.
- Install the four (4) bolts and tighten to specification.  
Tighten  
9 N•m (80 lb-in)
- Remove the timing wheel tool.
- Adjust air gap of Magnetic Pickup, Refer to *Magnetic Pickup Air Gap Adjustment*.
- Start engine.
- Check for any DTC codes and clear.
- Verify engine is in closed loop and no MIL lights are present.

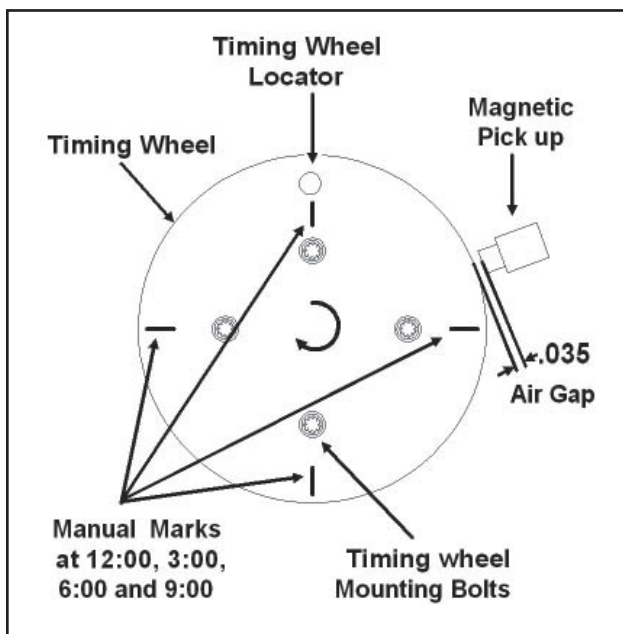

Figure 7 Installing Timing Wheel

## TIMING WHEEL REPLACEMENT WITHOUT SPECIAL TOOL

Figure 6

- Remove the four retaining bolts and lock washer and retain.
- Remove the timing wheel.

## Installation Procedure

### NOTE

Remove any debris from the magnetic sensor.

- Rotate crankshaft to position the TDC mark at 12:00.
- Align the locator mark on the timing wheel with the TDC mark on the crankshaft pulley.
- Install the four securing bolts and hand tighten.
- Using a marker mark the timing wheel at 12:00, 3:00, 6:00, and 9:00 positions.
- Place a .035 Brass feeler gauge between the sensor and the timing wheel with the crankshaft at 12:00 and insure feeler gauge moves in and out freely.
- Rotate the crankshaft to each of the marked positions and insure feeler gauge moves in out freely.
- If the gauge does not move freely at each of four marks loosen the four timing wheel retaining bolts and reposition the timing wheel and re secure hand tight and re-check air gap.
- Recheck air gap at all mark positions and tighten the four (4) retaining bolts to specification.

Tighten  
9 N•m (80 lb-in)

## MAGNETIC PICKUP SENSOR AIR GAP ADJUSTMENT

Figure 7

- Loosen the top and bottom Sensor Bracket bolts slightly and pivot the bracket away from the timing wheel

## WORKING LAMP KIT

### Description

This kit provides an auxiliary rear lamp for night or dark area of work.

### Installation

- (1) Install the bracket to the left rear head guard leg with U-bolt.
- (2) Connect the cord to harness B.

#### NOTE

Lamp works at second position of standard lighting switch.

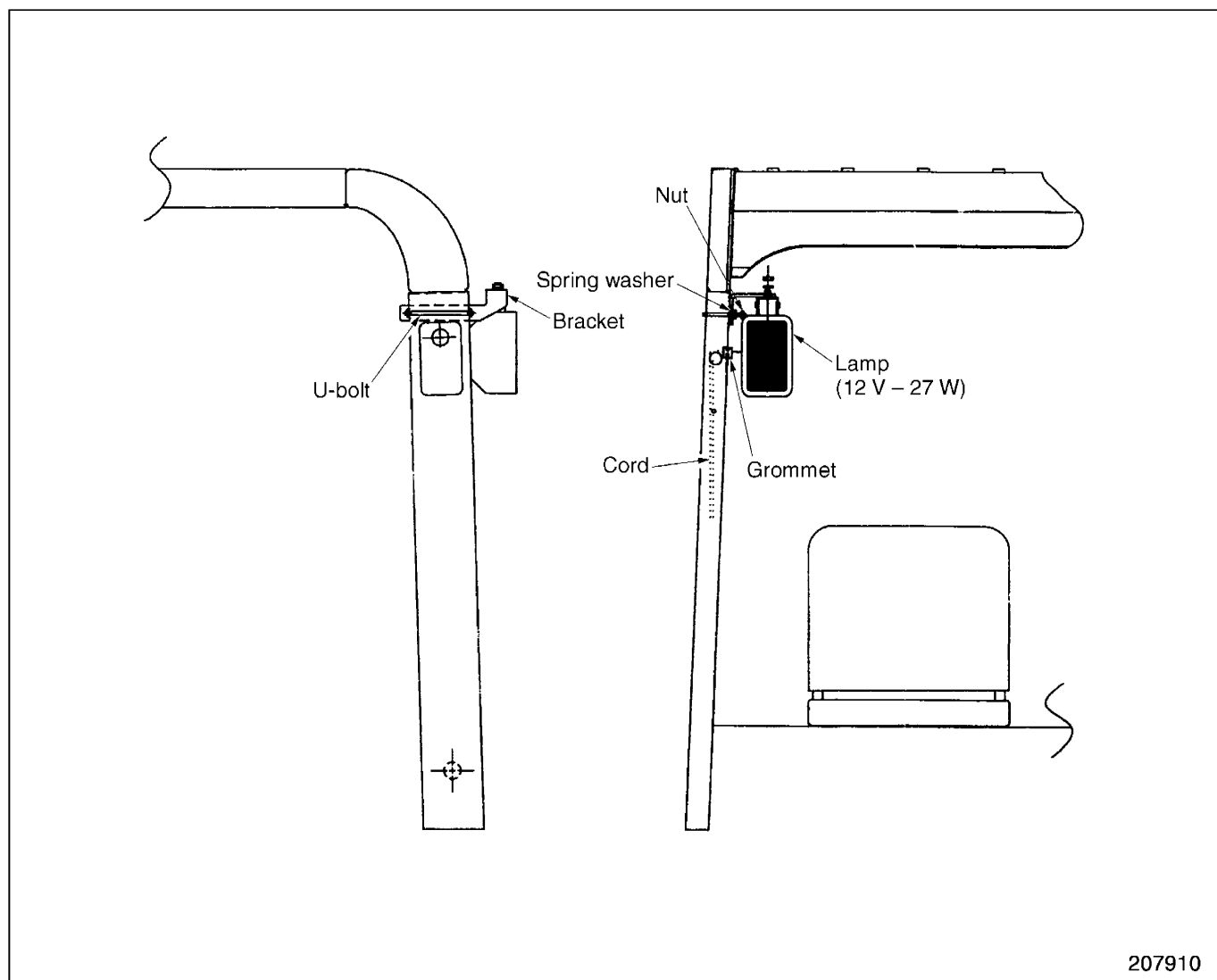

207910

CLICK HERE TO **DOWNLOAD** THE COMPLETE MANUAL

- Thank you very much for reading the preview of the manual.
- You can download the complete manual from: [www.heydownloads.com](http://www.heydownloads.com) by clicking the link below



- Please note: If there is no response to CLICKING the link, please download this PDF first and then click on it.

CLICK HERE TO **DOWNLOAD** THE COMPLETE MANUAL