



YFM45FAR YFM450FAR

5ND2-AE1

SERVICE MANUAL

CLICK HERE TO **DOWNLOAD** THE COMPLETE MANUAL

- Thank you very much for reading the preview of the manual.
- You can download the complete manual from: www.heydownloads.com by clicking the link below



- Please note: If there is no response to CLICKING the link, please download this PDF first and then click on it.

CLICK HERE TO **DOWNLOAD** THE COMPLETE MANUAL

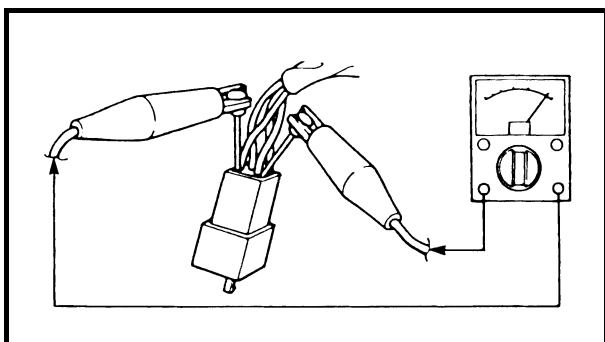
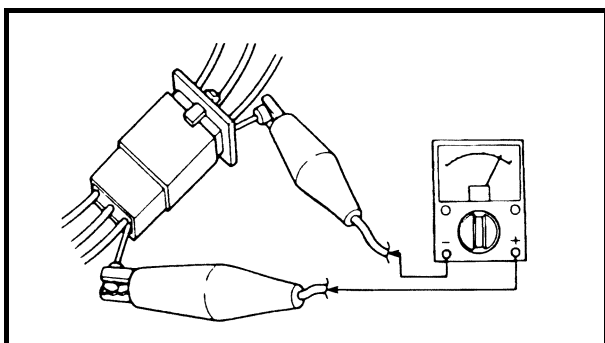
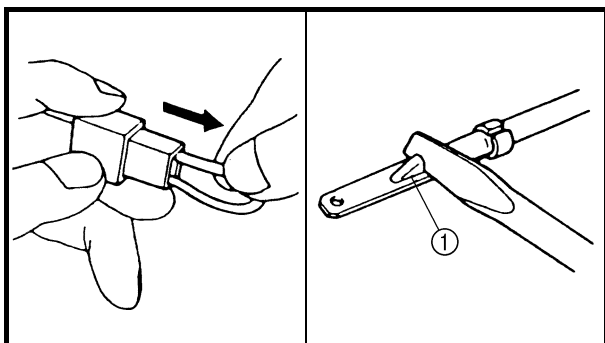
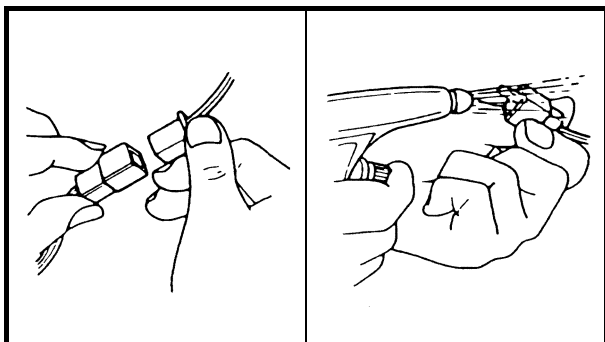

EB801000

CHECKING OF CONNECTIONS

Check the connectors for stains, rust, moisture, etc.

1. Disconnect:

- Connector

2. Check:

- Connector

Moisture → Dry each terminal with an air blower.

Stains/rust → Connect and disconnect the terminals several times.

3. Check:

- Connector leads

Looseness → Bend up the pin ① and connect the terminals.

4. Connect:

- Connector terminals

NOTE:

The two terminals “click” together.

5. Check:

- Continuity (using a pocket tester)







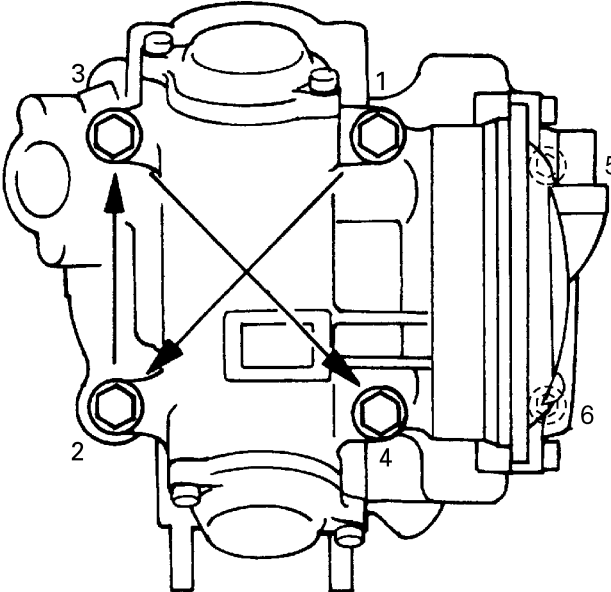























NOTE:

- If there is no continuity, clean the terminals.
- When checking the wire harness be sure to perform steps 1 to 3.
- As a quick remedy, use a contact revitalizer available at most part stores.
- Check the connector with a pocket tester as shown.



Item	Standard	Limit
<p>Cylinder head tightening sequence:</p> 		

LUBRICATION POINTS AND LUBRICANT TYPES
ENGINE

Lubrication points	Lubricant type
Oil seal lips (all)	
O-ring (all)	
Bearings (all)	
Crank pin	
Connecting rod (bearing)	
Camshaft sprocket	
Crankshaft	
Piston surface/piston rings	
Piston pin	
Buffer boss	
Valve stem/valve stem end	
Rocker arm shaft	
Rocker arm	
Camshaft lobe/journal	
Cylinder head bolt	
Oil pump shaft, rotor, housing	
Oil filter O-ring	
Starter idle gear shaft	
Transmission gear (wheel/pinion)	
Axle (main/drive)	
Shift fork/guide bar	
Shift cam/shift shaft/shift cam stopper ball	
Shift lever (select lever)/shift guide	
Shift cam lever	
Stopper lever	
Clutch housing	
One-way bearing	
Drive chain/sprocket	
Driven cam	
Front drive shaft collar	
Crankcase mating surfaces	Sealant (Quick Gasket®) Yamaha Bond No.1215
Stater lead grommet (left side crankcase)	Sealant (Quick Gasket®) Yamaha Bond No.1215



- ① Cylinder head breather hose
- ② Final drive gear case breather hose
- ③ Wire harness
- ④ Starter motor lead
- ⑤ Negative battery lead
- ⑥ Air filter case check hose
- ⑦ Water pump breather hose
- ⑧ Radiator outlet hose
- ⑨ Starter cable
- ⑩ Float chamber air vent hose
- ⑪ Cylinder head breather hose

- ⑫ Fuel hose
- ⑬ Low-range switch
- ⑭ High-range switch
- ⑮ Neutral switch lead
- ⑯ Reverse switch lead
- ⑰ Rectifier/regulator

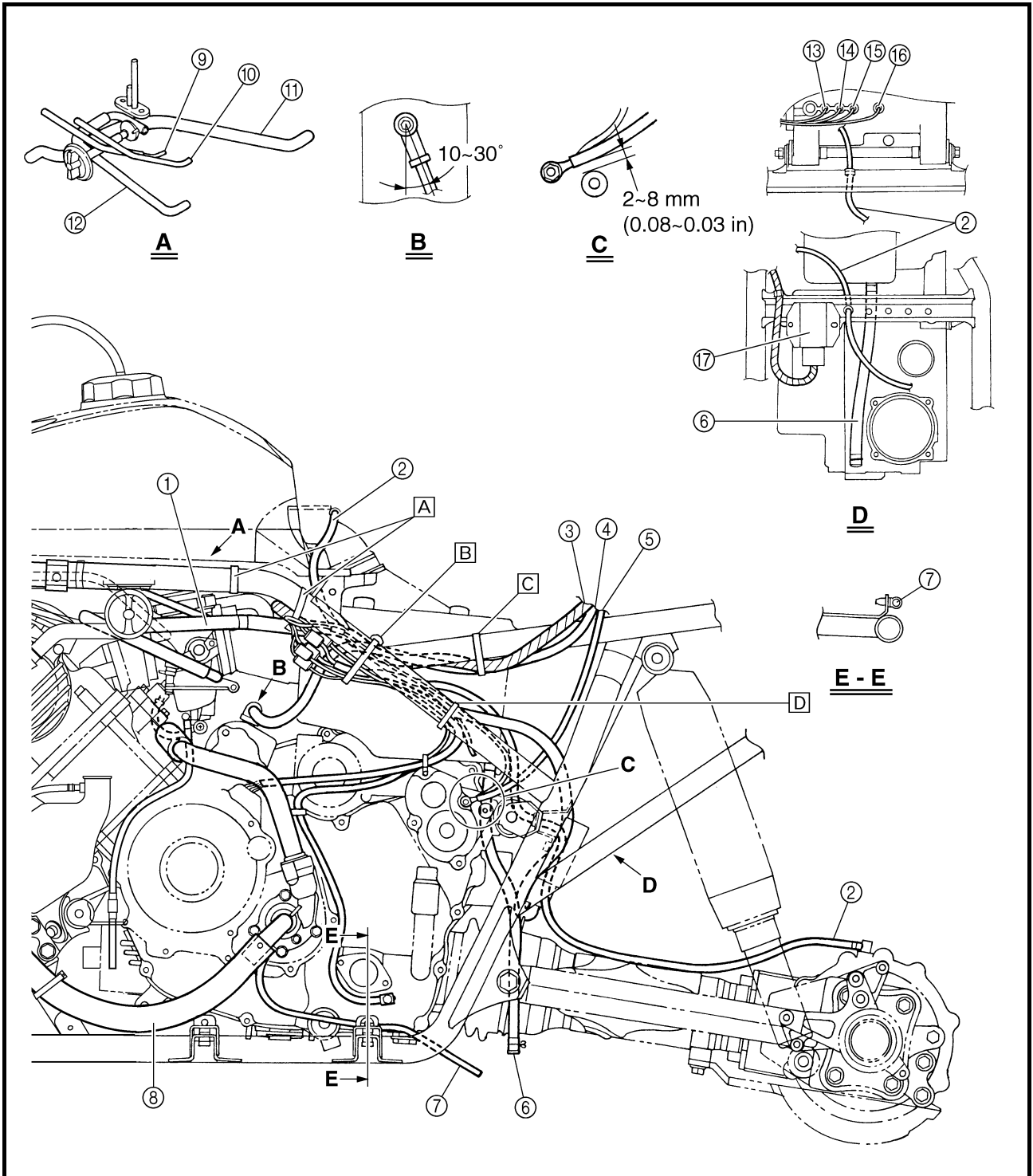

PERIODIC MAINTENANCE/LUBRICATION



ITEM	ROUTINE	Whichever comes first ⇨	INITIAL			EVERY		
			km (mile)	320 (200)	1,200 (750)	2,400 (1,500)	2,400 (1,500)	4,800 (3,000)
			hours	20	75	150	150	300
Front and rear suspension*	<ul style="list-style-type: none"> • Check operation. • Correct if necessary. 				○		○	
Steering system*	<ul style="list-style-type: none"> • Check operation./Replace if damaged. • Check toe-in./Adjust if necessary. 		○	○	○	○	○	
Drive shaft universal joint*	<ul style="list-style-type: none"> • Lubricate.** 				○	○	○	
Engine mount*	<ul style="list-style-type: none"> • Check for cracks or damage. 				○	○	○	
Front axle boots*	<ul style="list-style-type: none"> • Check operation. • Replace if damaged. 		○				○	
Fittings and fasteners*	<ul style="list-style-type: none"> • Check all chassis fittings and fasteners. • Correct if necessary. 		○	○	○	○	○	

* It is recommended that these items be serviced by a Yamaha dealer.

** Lithium-soap-based grease

NOTE:

- Recommended brake fluid: DOT 4
- Brake fluid replacement:
 1. When disassembling the master cylinder or caliper, replace the brake fluid. Normally check the brake fluid level and add fluid as required.
 2. On the inner parts of the master cylinder and caliper, replace the oil seals every two years.
 3. Replace the brake hoses every four years, or if cracked or damaged.

⚠ WARNING

Indicates a potential hazard that could result in serious injury or death.

ADJUSTING THE VALVE CLEARANCE

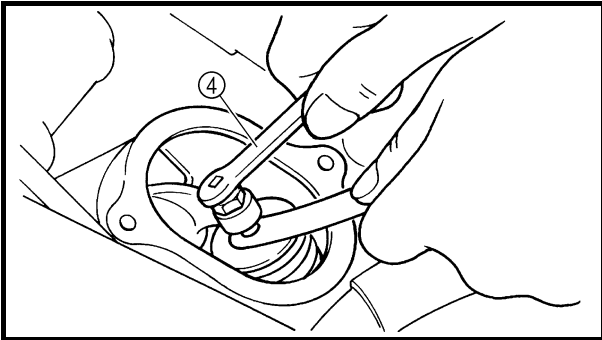
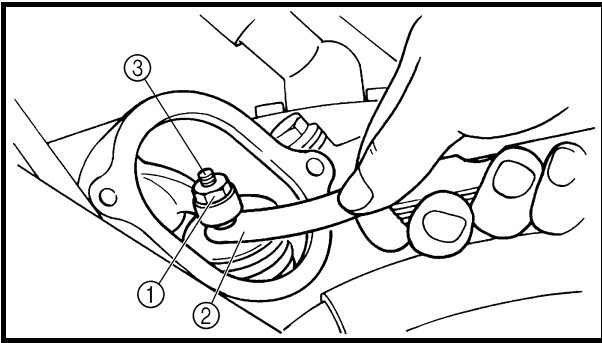

8.Adjust:

- Valve clearance

Adjustment steps:

- Loosen the locknut ①.
- Insert a feeler gauge ② between the adjuster end and the valve end.
- Turn the adjuster ③ clockwise or counterclockwise with the valve adjusting tool ④ until the proper clearance is obtained.



Tappet adjusting tool:
P/N. YM-08035, 90890-01311

- Hold the adjuster to prevent it from moving and then tighten the locknut.



Locknut:
20 Nm (2.0 m • kg, 14 ft • lb)

- Measure the valve clearance.
- If the clearance is incorrect, repeat the above steps until the proper clearance is obtained.

9.Install:

- All removed parts

NOTE:

Install all removed parts in the reverse order of their disassembly. Note the following points.

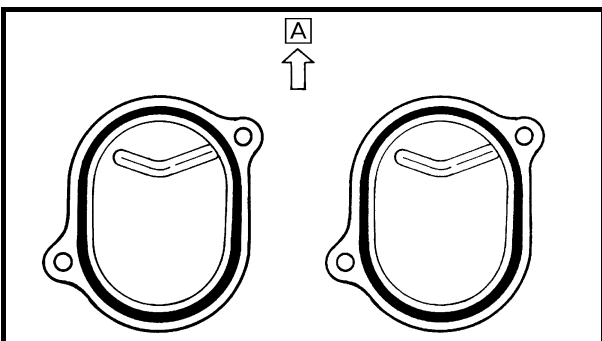

10.Install:

- Recoil starter

10 Nm (1.0 m • kg, 7.2 ft • lb)

- Spark plug

18 Nm (1.8 m • kg, 13 ft • lb)

- Tappet covers

10 Nm (1.0 m • kg, 7.2 ft • lb)

NOTE:

Install the tappet covers with the ridge facing up .

7.Measure:

- Compression pressure
 - Above the maximum pressure:
 - Check the cylinder head, valve surfaces, and piston crown for carbon deposits.
 - Below the minimum pressure:
 - Squirt a few drops of oil into the affected cylinder and measure again.
- Refer to the table below.

Compression pressure (with oil introduced into cylinder)	
Reading	Diagnosis
Higher than without oil	Worn or damaged pistons
Same as without oil	Defective ring(s), valves, cylinder head gasket or piston is possible.

	Compression pressure (at sea level): Standard: 1,270 kPa (12.7 kg/cm ² , 181 psi) Minimum: 1,105 kPa (11.1 kg/cm ² , 158 psi) Maximum: 1,422 kPa (14.2 kg/cm ² , 202 psi)
--	--

Measurement steps:

- Crank over the engine with the electric starter (be sure the battery is fully charged) with the throttle wide-open until the compression reading on the gauge stabilizes.

⚠ WARNING

When cranking the engine, ground the spark plug lead to prevent sparking.

8.Install:

- Spark plug  **18 Nm (1.8 m • kg, 13 ft • lb)**

9.Remove:

- Fuel tank side panel (right)
 - Seat
- Refer to “SEAT, CARRIERS, FENDERS AND FUEL TANK”.

CAUTION:

- Adding water instead of coolant lowers the antifreeze content of the coolant. If water is used instead of coolant, check, and if necessary, correct the antifreeze concentration of the coolant.
- Use only distilled water. However, soft water may be used if distilled water is not available.
- If coolant comes into contact with painted surfaces, immediately wash them with water.
- Do not mix different types of antifreeze.

13. Install:

- Radiator cap

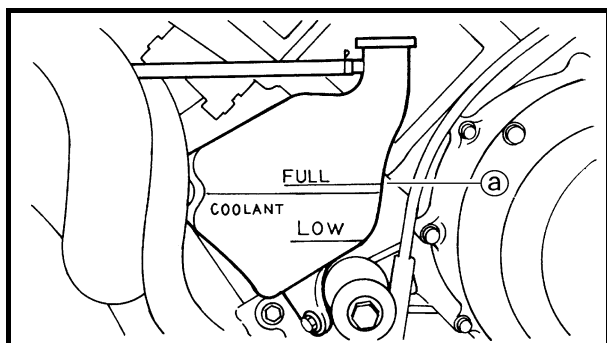

14. Fill:

- Coolant reservoir (with the recommended coolant to the maximum level mark (a))

15. Install:

- Coolant reservoir cap

16. Start the engine, warm it up for several minutes, and then turn it off.

17. Check:

- Coolant level
Refer to "CHECKING THE COOLANT LEVEL".

NOTE:

Before checking the coolant level, wait a few minutes until the coolant has settled.

18. Install:

- Left footrest board
Refer to "FOOTREST BOARDS".
- Front fender
- Engine skid plate
- Front carrier
- Engine side cover
- Fuel tank side panel (left)
- Seat
Refer to "SEAT, CARRIERS, FENDERS AND FUEL TANK".

k. Add brake fluid to the proper level.

Refer to "CHECKING THE BRAKE FLUID LEVEL".

⚠ WARNING

Check the operation of the brake after bleeding the brake system.

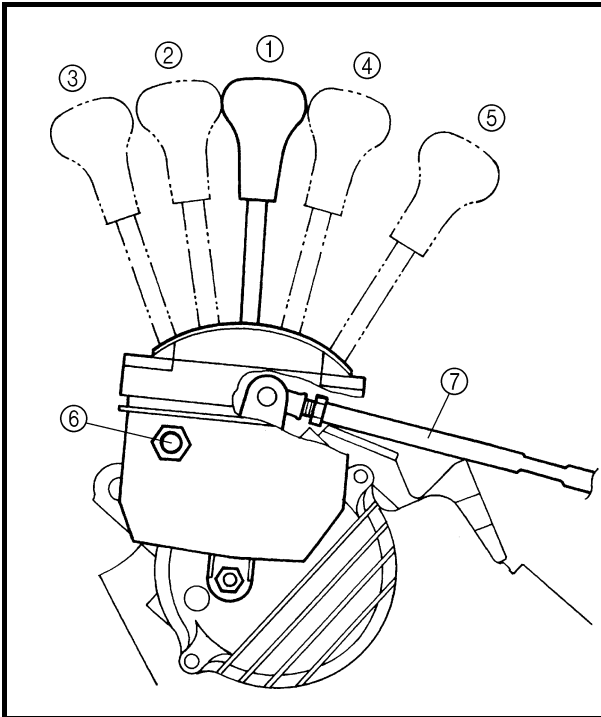

ADJUSTING THE SELECT LEVER CONTROL CABLE AND SHIFT ROD

- ① NEUTRAL
- ② HIGH
- ③ LOW
- ④ REVERSE
- ⑤ PARK
- ⑥ Control cable
- ⑦ Select lever shift rod

⚠ WARNING

Before moving the select lever, bring the machine to a complete stop and return the throttle lever to its closed position. Otherwise the transmission may be damaged.

1. Adjust:

- Rear brake pedal free play
Refer to "ADJUSTING THE REAR BRAKE".

2. Adjust:

- Select lever control cable
- Select lever shift rod

Adjustment steps:

Control cable:

- Make sure the select lever is in NEUTRAL.
- Adjust the control cable so there is zero free play in the cable. When the adjustment is correct, slack in the return spring ① will be taken up.

NOTE:

In some cases it will be necessary to further adjust the cable with the locknuts ② arrangement that holds the cable to its mount.

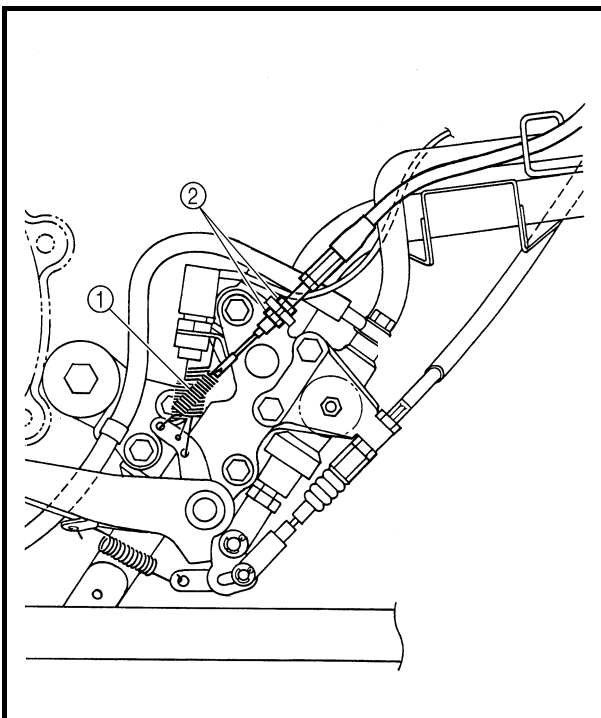

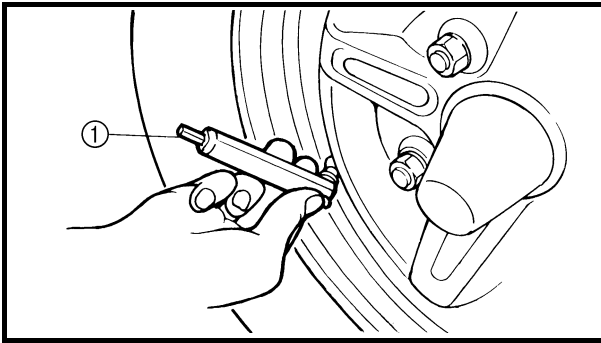

1. Measure:

- Tire pressure (cold tire pressure)
Out of specification → Adjust.

NOTE:

- The low-pressure tire gauge ① is included as standard equipment.
- If dust or the like is stuck to this gauge, it will not provide the correct readings. Therefore, take two measurements of the tire's pressure and use the second reading.

Cold tire pressure	Front	Rear
Standard	25 kPa (0.25 kg/cm ² , 3.6 psi)	25 kPa (0.25 kg/cm ² , 3.6 psi)
Minimum	22 kPa (0.22 kg/cm ² , 3.2 psi)	22 kPa (0.22 kg/cm ² , 3.2 psi)
Maximum	28 kPa (0.28 kg/cm ² , 4.0 psi)	28 kPa (0.28 kg/cm ² , 4.0 psi)

⚠ WARNING

Uneven or improper tire pressure may adversely affect the handling of this machine and may cause loss of control.

- Maintain proper tire pressures.
- Set tire pressures when the tires are cold.
- Tire pressures must be equal in both front tires and equal in both rear tires.

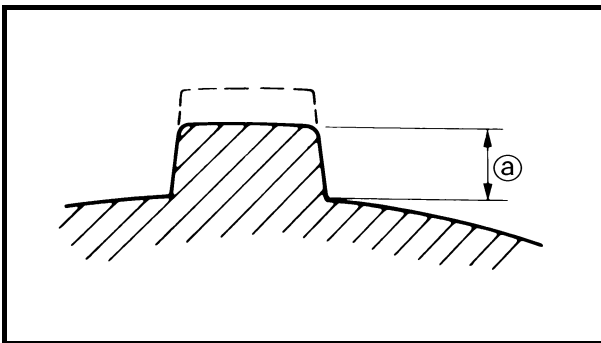

2. Check:

- Tire surfaces
Wear/damage → Replace.



Tire wear limit ②:
Front and rear: 3.0 mm (0.12 in)

⚠ WARNING

It is dangerous to ride with a worn-out tire. When tire wear is out of specification, replace the tire immediately.



Shims are supplied in the following thickness.

	Middle drive pinion gear shim	
Thickness (mm)	0.10	0.40
	0.15	0.50
	0.20	0.60
	0.30	

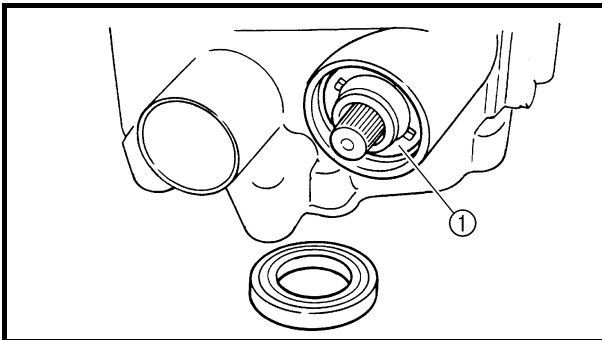

INSTALLING THE MIDDLE DRIVEN SHAFT

1. Install:

- Bearing retainer ① 

 **80 Nm (8.0 m • kg, 58 ft • lb)**

NOTE:

Attach the ring nut wrench ②.



Ring nut wrench:
P/N. YM-38404, 90890-01430

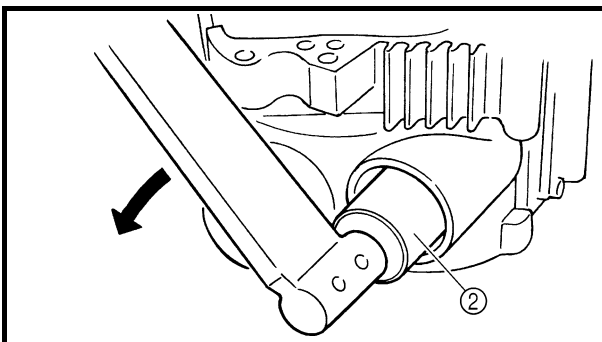

CAUTION:

The middle driven shaft bearing retainer has left-handed threads. To tighten the retainer turn it counterclockwise.

2. Install:

- Bearing retainer ① 

Installation steps:

- Attach the folded rag ②.
- Secure the bearing housing edge in the vise.
- Attach the bearing retainer wrench ③.

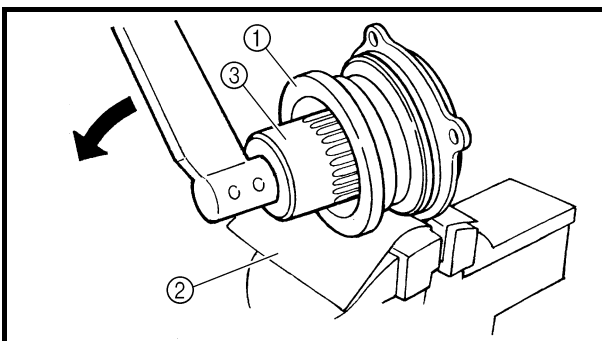

Bearing retainer wrench:
P/N. YM-04128, 90890-04128

**INSTALLING THE RADIATOR****1.Fill:**

- Cooling system
(with the specified amount of the recommended coolant)
Refer to “CHANGING THE COOLANT” in CHAPTER 3.

2.Check:

- Cooling system
Leaks → Repair or replace any faulty part.

CLICK HERE TO **DOWNLOAD** THE COMPLETE MANUAL

- Thank you very much for reading the preview of the manual.
- You can download the complete manual from: www.heydownloads.com by clicking the link below



- Please note: If there is no response to CLICKING the link, please download this PDF first and then click on it.

CLICK HERE TO **DOWNLOAD** THE COMPLETE MANUAL

CHAPTER 6. CARBURETION

CARBURETOR	6-1
CHECKING THE CARBURETOR	6-4
ASSEMBLING THE CARBURETOR	6-6
ADJUSTING THE FUEL LEVEL	6-7

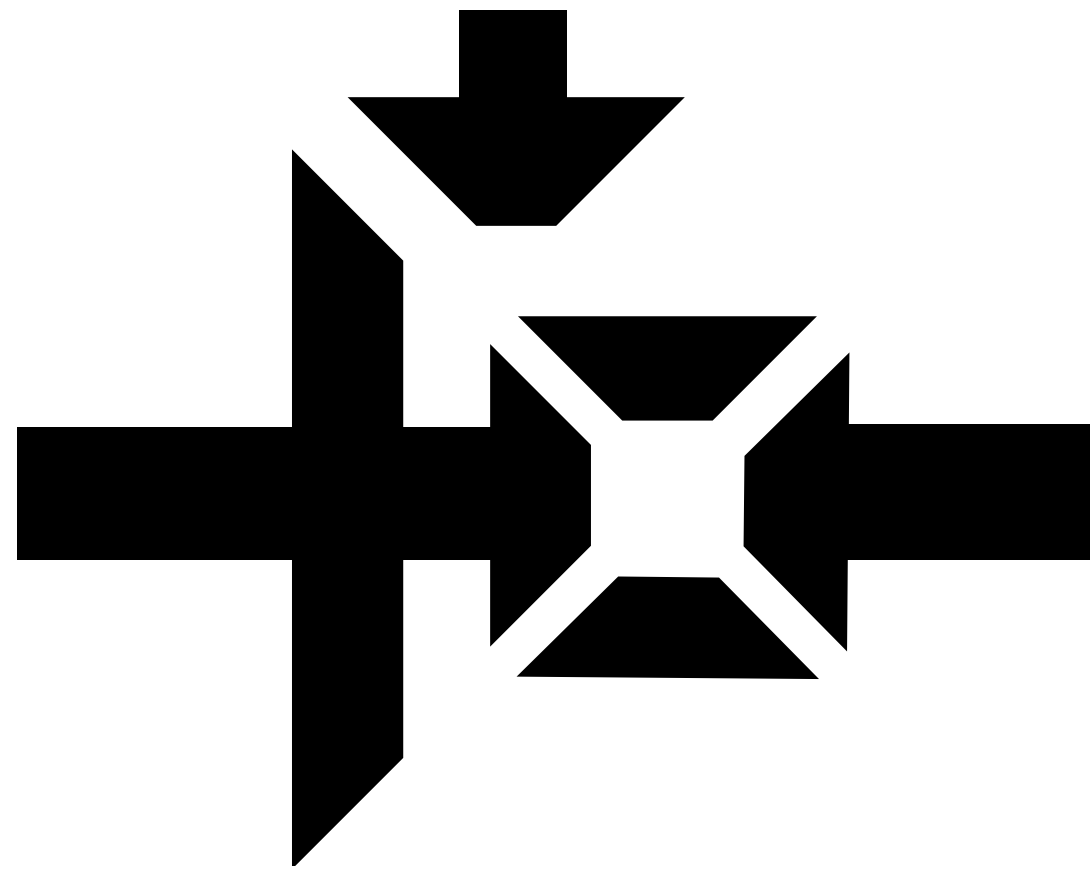

DRIV

7

FRONT CONSTANT VELOCITY JOINTS AND DIFFERENTIAL GEAR

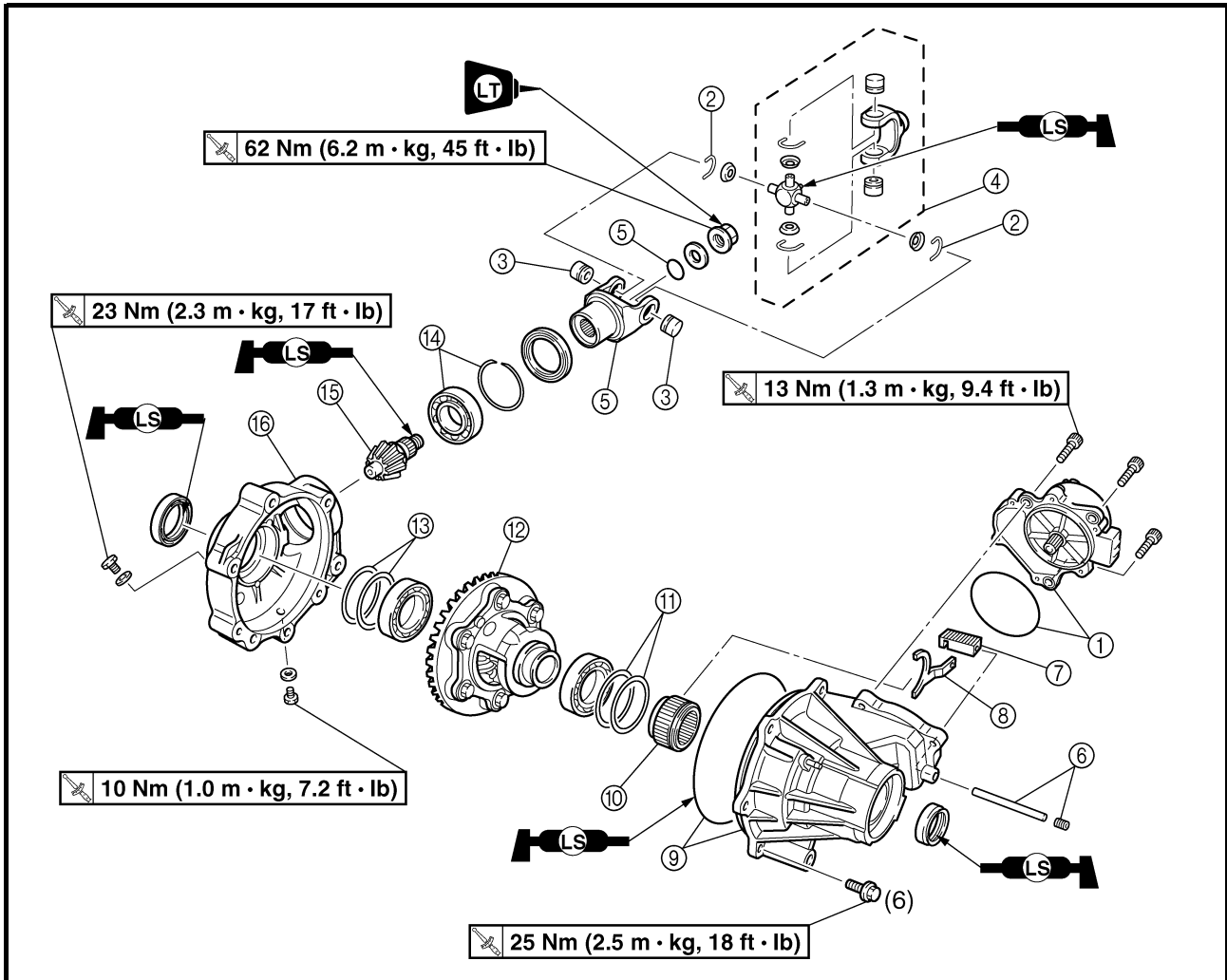

Order	Job name/Part name	Q'ty	Remarks
⑫	Differential gear assembly	1	For assembly, reverse the disassembly procedure.
⑬	Shim (right)	1	
⑭	Circlip/bearing	1/1	
⑮	Drive pinion gear	1	
⑯	Differential gear case	1	

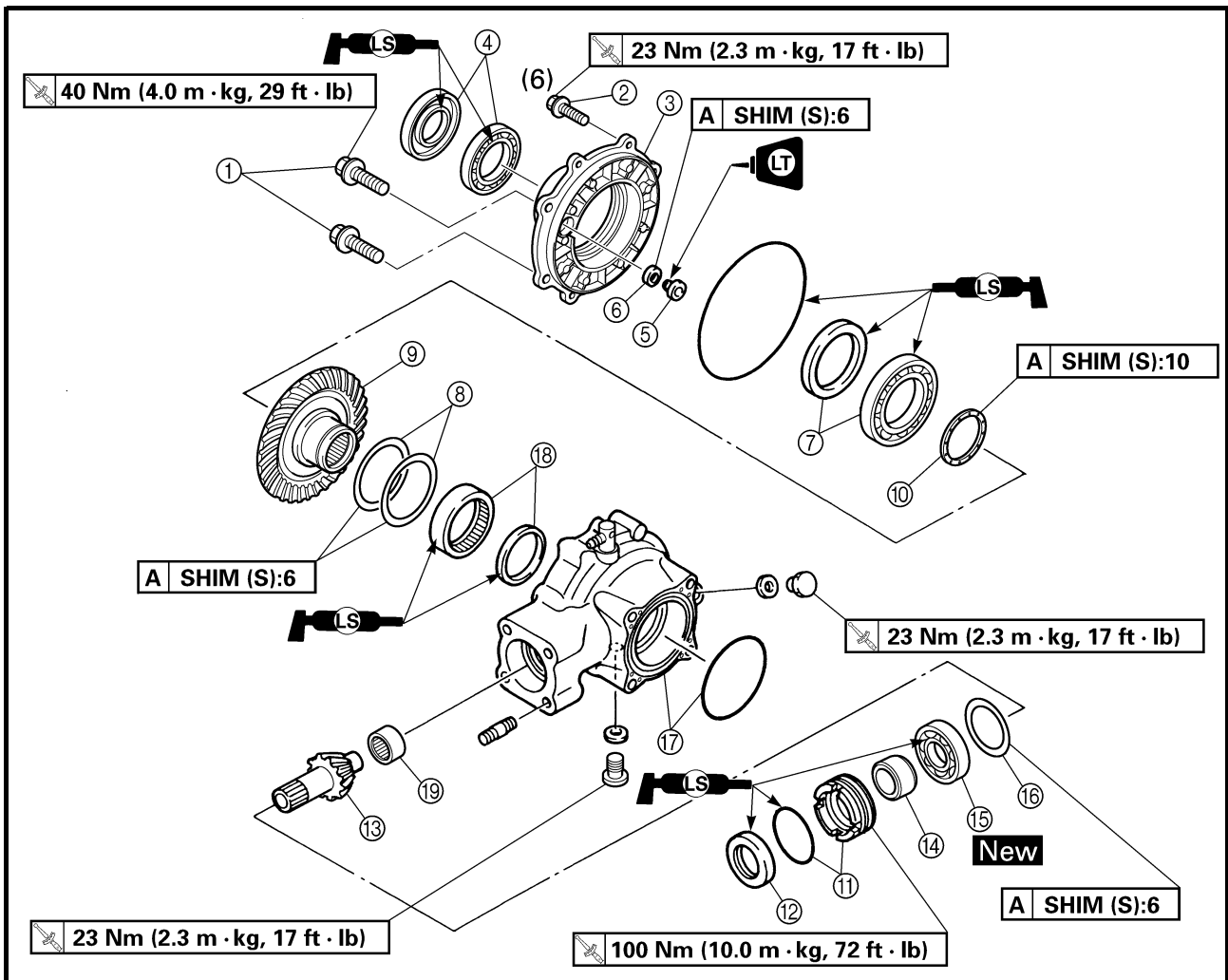

Order	Job name/Part name	Q'ty	Remarks
	Disassembling the final drive gear		Remove the parts in the order below.
①	Bolt	2	NOTE: _____ Working in a crisscross pattern, loosen each bolt 1/4 of a turn. After all the bolts are loosened, remove them.
②	Bolt	6	
③	Bearing housing	1	
④	Oil seal/bearing	1/1	
⑤	Ring gear stopper	1	
⑥	Ring gear stopper shim	1	
⑦	Oil seal/bearing	1/1	
⑧	Ring gear shim	1	
⑨	Ring gear	1	
⑩	Thrust washer	1	

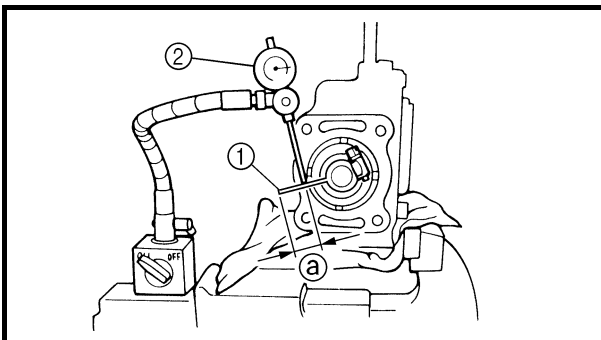
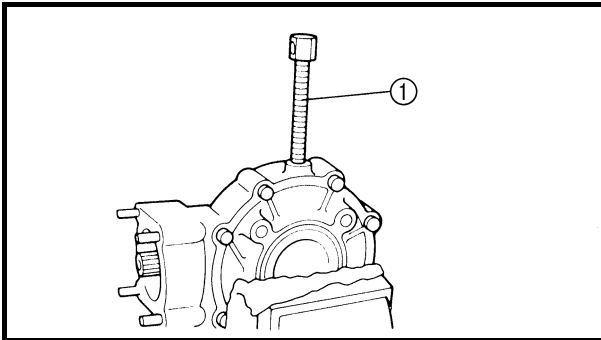
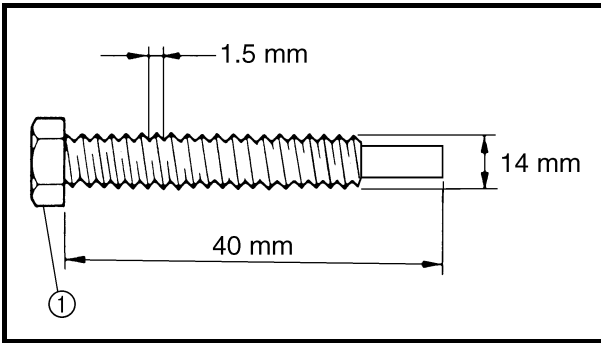

MEASUREMENT AND ADJUSTING THE FINAL GEAR LASH

Final gear lash measurement

1. Secure the gear case in a vise or another supporting device.
2. Remove:
 - Drain plug
 - Gasket
3. Install:
 - A bolt of the specified size ① (into the drain plug hole)

CAUTION:

Finger tighten the bolt until it holds the ring gear. Otherwise, the ring gear will be damaged.

4. Attach:
 - Gear lash measurement tool ①
 - Dial gauge ②



**Gear lash measurement tool:
P/N. YM-01475, 90890-01475**

① Measuring point is 31.46 mm (1.24 in)

5. Measure:
 - Gear lash
Gently rotate the gear coupling from engagement to engagement.



**Final gear lash:
0.1 ~ 0.2 mm (0.004 ~ 0.008 in)**

NOTE:

Measure the gear lash at four positions. Rotate the shaft 90° each time.

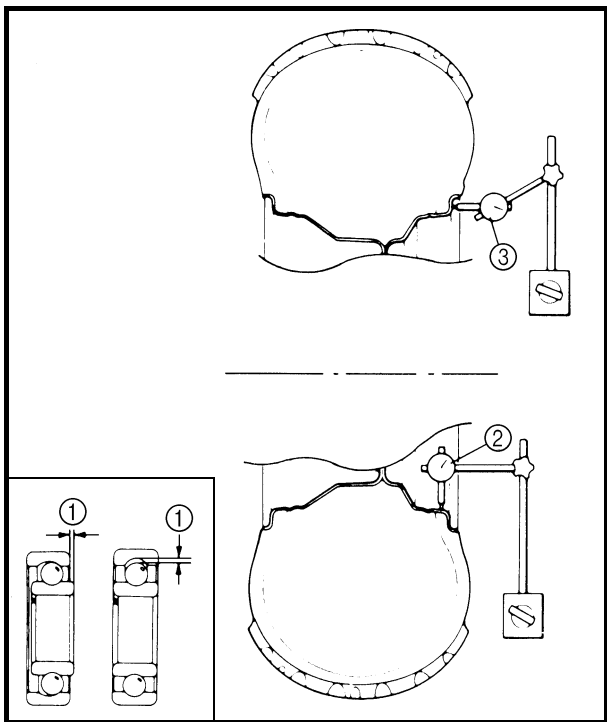

CHECKING THE WHEEL

1. Check:
 - Wheel
2. Measure:
 - Wheel runout
 - Over the specified limit → Replace the wheel or check the wheel bearing play ①.



Wheel runout limit:
 Radial ②: 2.0 mm (0.08 in)
 Lateral ③: 2.0 mm (0.08 in)

3. Check:
 - Wheel balance
 - Out of balance → Adjust.

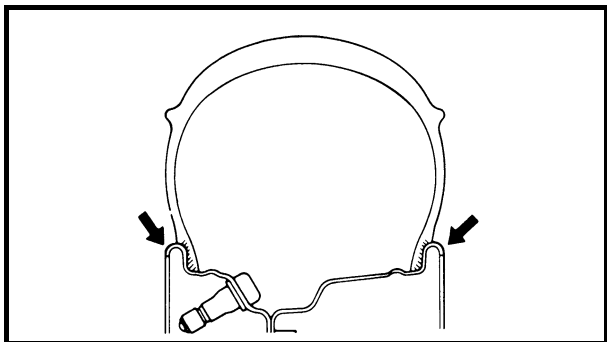

⚠ WARNING

After replacing the tire, ride conservatively to allow the tire to be properly seated in the rim. Failure to do so may cause an accident resulting in machine damage and possible operator injury.

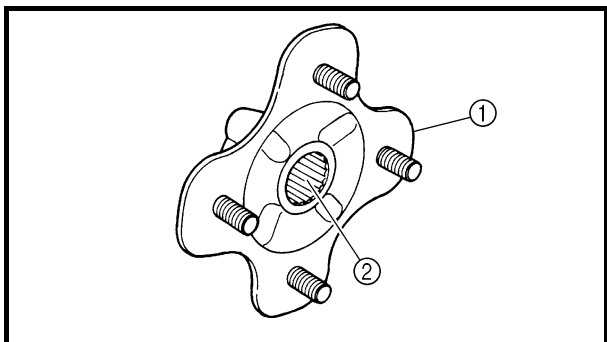

CHECKING THE WHEEL HUB

1. Check:
 - Wheel hub ①
 - Cracks/damage → Replace.
 - Splines (wheel hub) ②
 - Wear/damage → Replace.

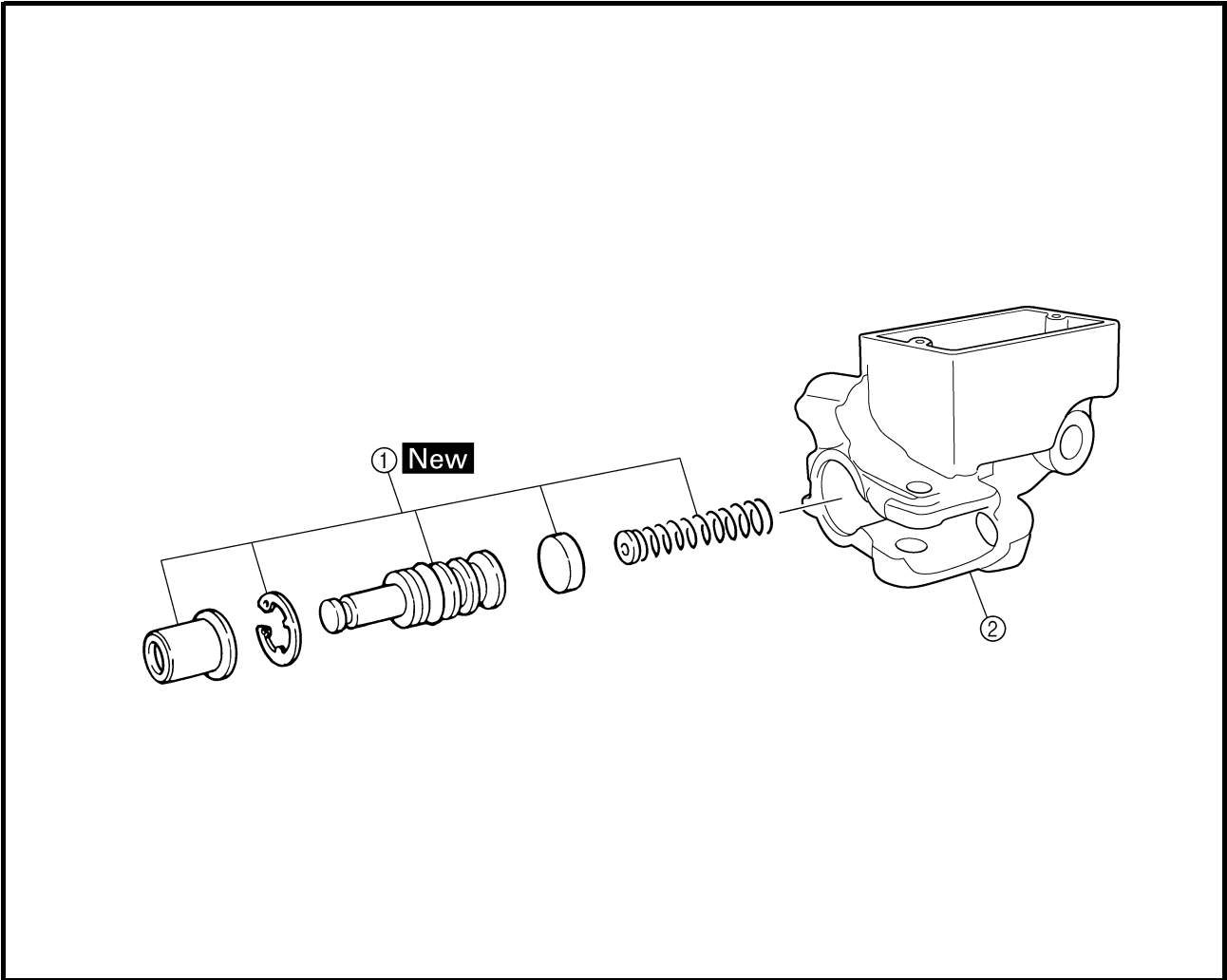

Order	Job name/Part name	Q'ty	Remarks
	Disassembling the front brake master cylinder		Remove the parts in the order below.
①	Brake master cylinder kit	1	Refer to "ASSEMBLING THE FRONT BRAKE MASTER CYLINDER". For assembly, reverse the disassembly procedure.
②	Brake master cylinder	1	

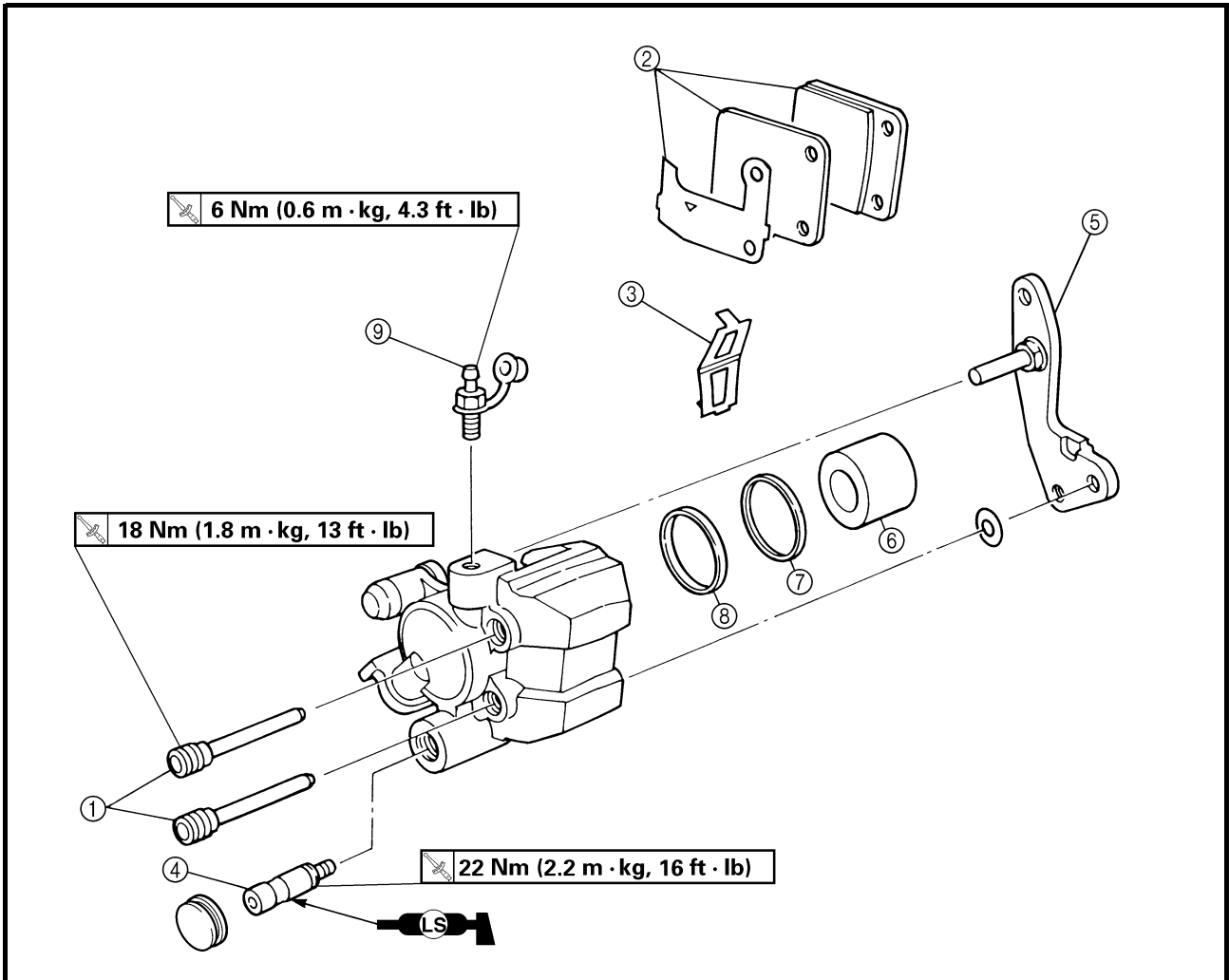

Order	Job name/Part name	Q'ty	Remarks
	Disassembling the front brake caliper		Remove the parts in the order below.
①	Brake pad holding bolt	2	
②	Brake pad/pad shim	2/1	
③	Pad spring	1	
④	Retaining bolt	1	
⑤	Caliper bracket	1	
⑥	Brake caliper piston	1	Refer to "DISASSEMBLING/ -ASSEMBLING THE FRONT AND REAR BRAKE CALIPER".
⑦	Dust seal	1	
⑧	Caliper piston seal	1	
⑨	Bleed screw	1	
			For assembly, reverse the disassembly procedure.



STEERING STEM

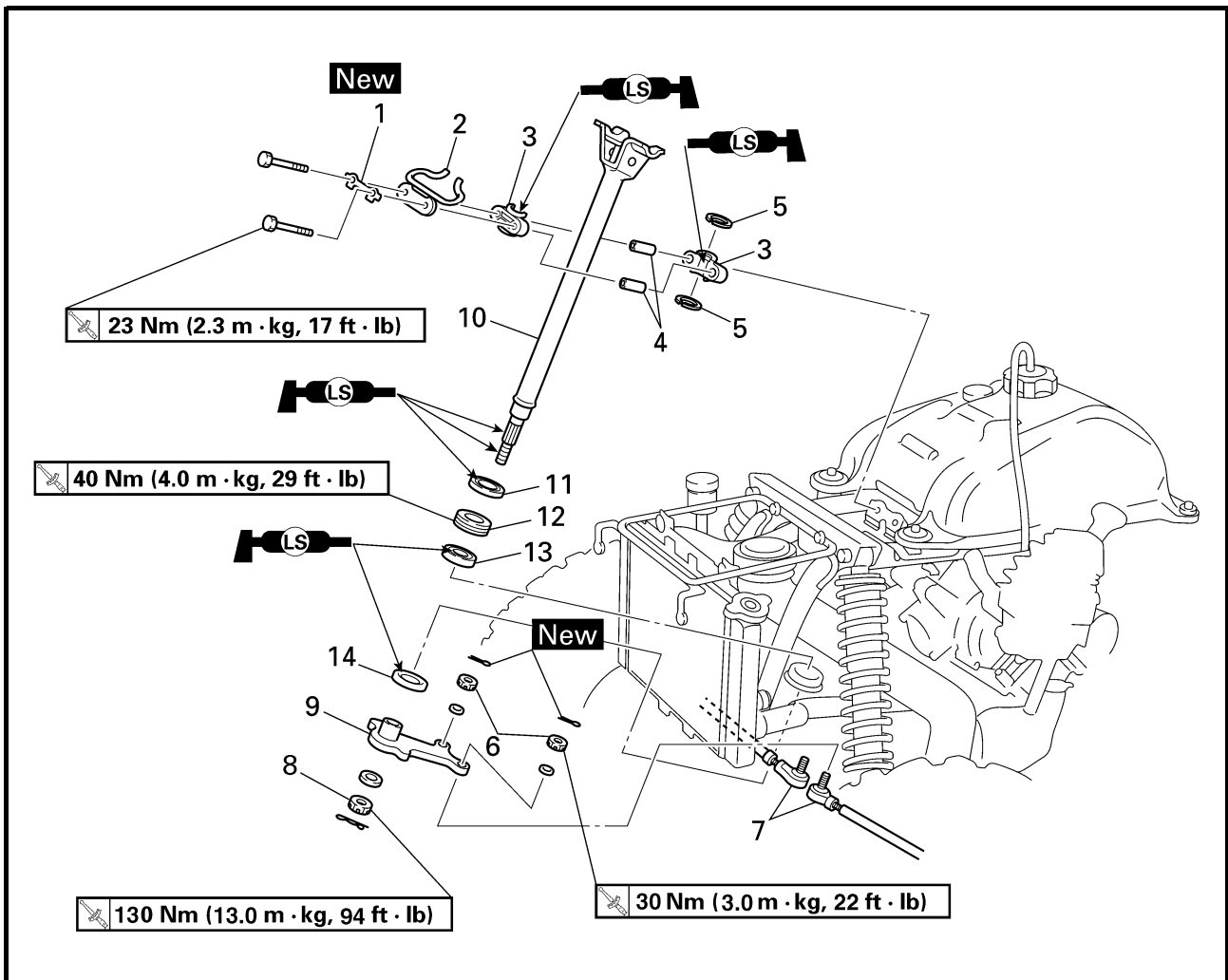

Order	Job name/Part name	Q'ty	Remarks
	Removing the steering stem		Remove the parts in the order below.
	Handlebar		Refer to "HANDLEBAR".
	Seat		Refer to "SEAT, CARRIERS, FENDERS AND FUEL TANK" in CHAPTER 3.
	Front fender		
1	Lock washer	1	Refer to "INSTALLING THE CABLE GUIDE".
2	Cable guide	1	
3	Steering stem bushing	2	
4	Collar	2	
5	Oil seal	2	
6	Tie rod end nut	2	
7	Tie rod	2	Disconnect.
8	Steering stem nut	1	
9	Pitman arm	1	
10	Steering stem	1	

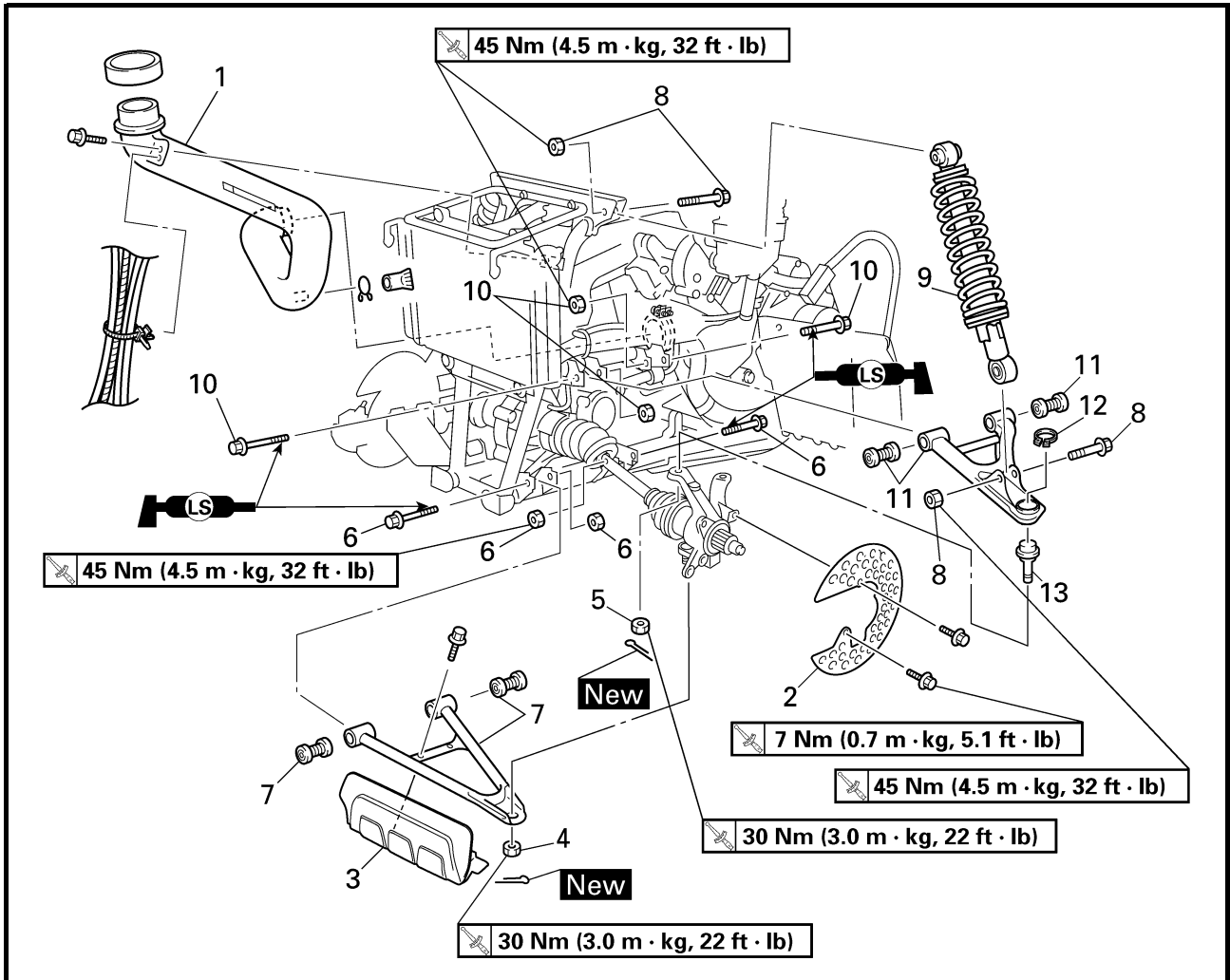

Order	Job name/Part name	Q'ty	Remarks
4	Nut	1	Refer to "REMOVING THE FRONT ARMS" and "INSTALLING THE FRONT ARMS AND FRONT SHOCK ABSORBER". For installation, reverse the removal procedure.
5	Nut	1	
6	Bolt/nut	2/2	
7	Front lower arm/bushing	1/2	
8	Nut/bolt	2/2	
9	Front shock absorber	1	
10	Bolt/nut	2/2	
11	Front upper arm/bushing	1/2	
12	Circlip	1	
13	Ball joint	1	

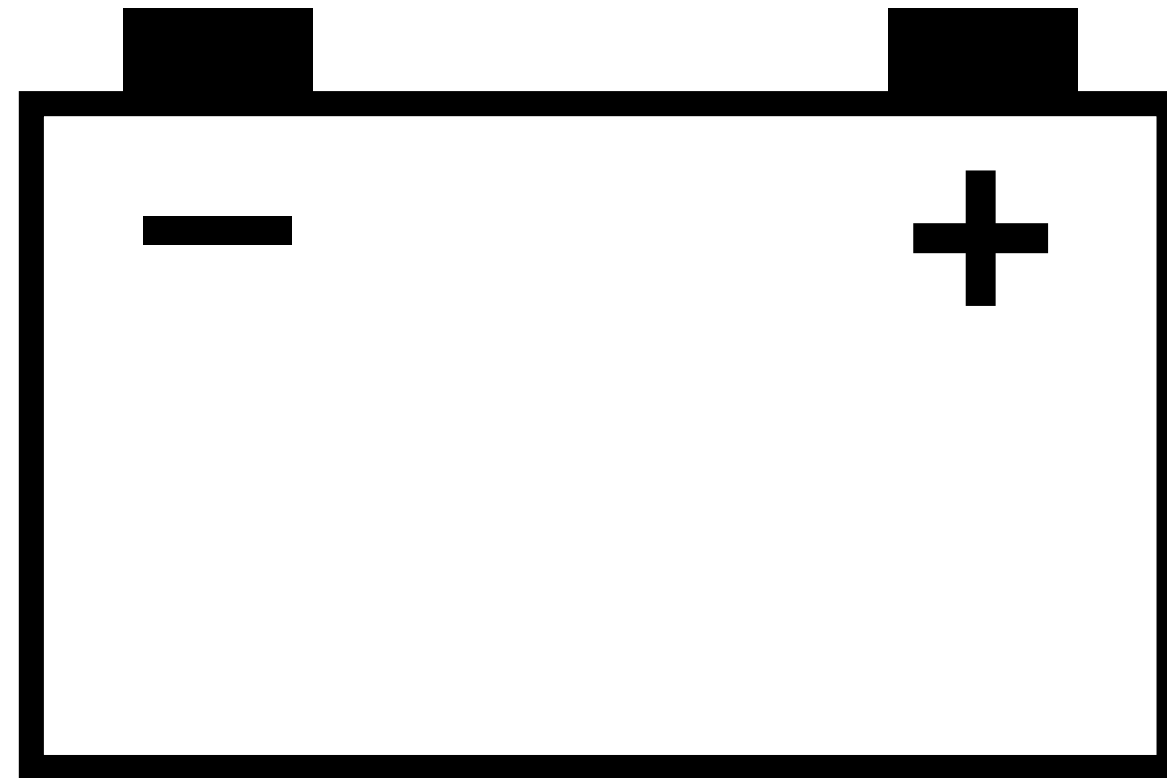

ELEEC

9

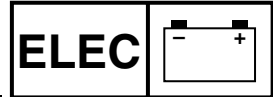

CHECKING THE CONDITION OF THE BULB SOCKETS

The following procedure applies to all of the bulb sockets.

1. Check:

- Bulb socket (for continuity)
(with the pocket tester)
No continuity → Replace.



Pocket tester:
P/N. YU-03112, 90890-03112

NOTE:

Check each bulb socket for continuity in the same manner as described in the bulb section; however, note the following.

- a. Install a good bulb into the bulb socket.
- b. Connect the pocket tester probes to the respective leads of the bulb socket.
- c. Check the bulb socket for continuity. If any of the readings indicate no continuity, replace the bulb socket.

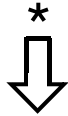

5. Main switch
Refer to "CHECKING THE SWITCH".

INCORRECT



Replace the main switch.



CORRECT

6. Engine stop switch
Refer to "CHECKING THE SWITCH".

INCORRECT



Replace the handlebar switch (left).



CORRECT

7. Start switch
Refer to "CHECKING THE SWITCH".

INCORRECT



Replace the handlebar switch (left).



CORRECT

EB803028

8. Wiring connection
• Check the connections of the entire starting system.
Refer to "CIRCUIT DIAGRAM".

POOR CONNECTION



Properly connect the starting system.

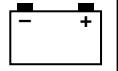

EB805020

CHECKING THE LIGHTING SYSTEM

1. If the headlights fail to come on:

1. Bulb and bulb socket

- Check the bulb and bulb socket for continuity.

NO CONTINUITY



Replace the bulb and/or bulb socket.

CONTINUITY



2. Voltage

- Connect the pocket tester (DC 20 V) to the headlight couplers.

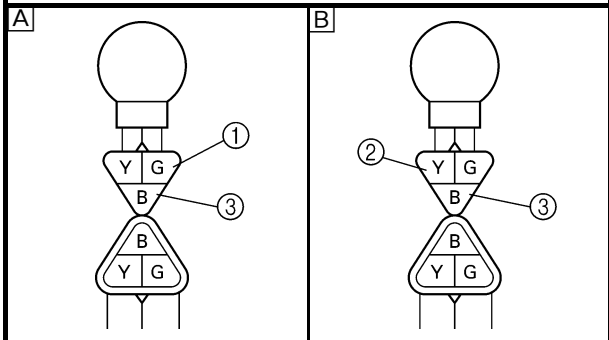

Tester (+) lead →
Green terminal ① or Yellow terminal ②
Tester (-) lead → **Black terminal ③**

A When the light switch is on “ ”.
B When the light switch is on “ ”.

- Turn the main switch to “ON”.
- Turn the light switch to “ ” or “ ”.
- Check the voltage (12 V) of the “Green” and “Yellow” leads on the bulb socket connector.

OUT OF SPECIFICATION



The wiring circuit from the main switch to the bulb socket connector is faulty, repair it.

MEETS SPECIFICATION



This circuit is not faulty.

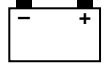

COOLING SYSTEM
CIRCUIT DIAGRAM

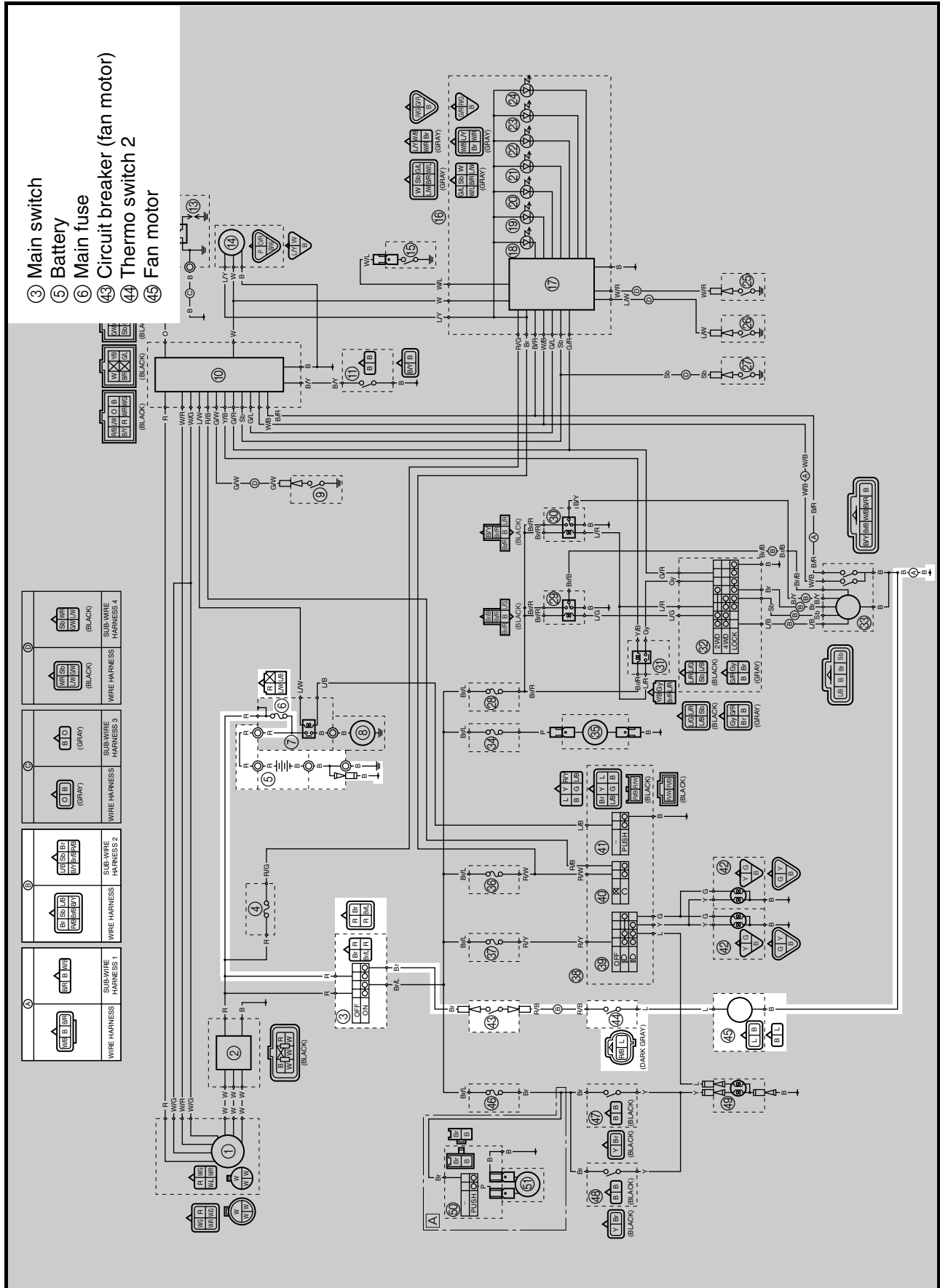

CLICK HERE TO **DOWNLOAD** THE COMPLETE MANUAL

- Thank you very much for reading the preview of the manual.
- You can download the complete manual from: www.heydownloads.com by clicking the link below



- Please note: If there is no response to CLICKING the link, please download this PDF first and then click on it.

CLICK HERE TO **DOWNLOAD** THE COMPLETE MANUAL