



**YAMAHA**

**XV16AL/XV16ALC  
XV16ATL/XV16ATLC**

**SERVICE MANUAL**

CLICK HERE TO **DOWNLOAD** THE COMPLETE MANUAL

- Thank you very much for reading the preview of the manual.
- You can download the complete manual from: [www.heydownloads.com](http://www.heydownloads.com) by clicking the link below



- Please note: If there is no response to CLICKING the link, please download this PDF first and then click on it.

CLICK HERE TO **DOWNLOAD** THE COMPLETE MANUAL

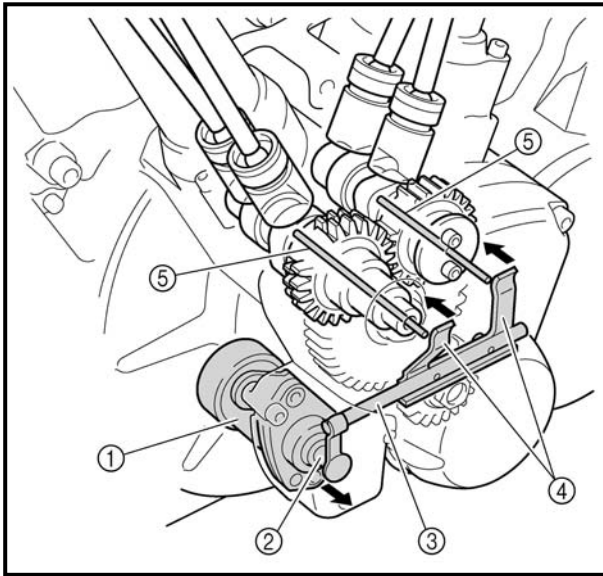

**Operation**

1. When the starter switch is pushed, electricity is run to the decompression solenoid ① causing it to push out the decompression solenoid rod ②.
2. When the decompression solenoid rod is pushed out, the decompression connector ③ moves the decompression levers ④ in the direction indicated by the arrows, and then the levers push the decompression rods ⑤ toward the camshaft side.

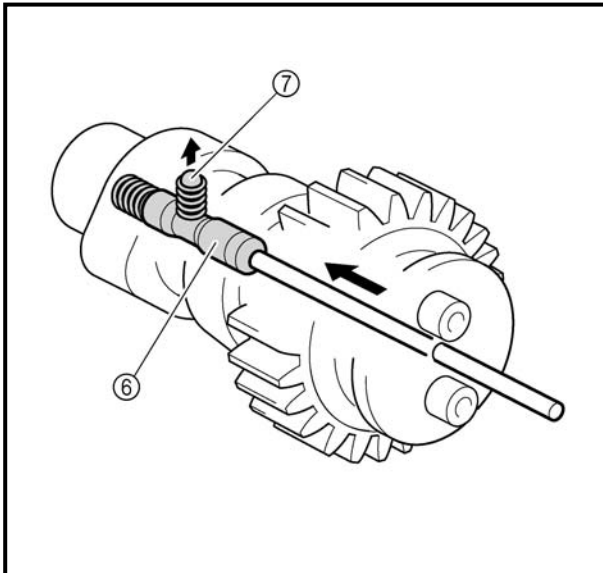

3. The decompression cam ⑥ is pushed in the direction indicated by the arrow, and then the pin ⑦ raises the projection of the decompression cam.

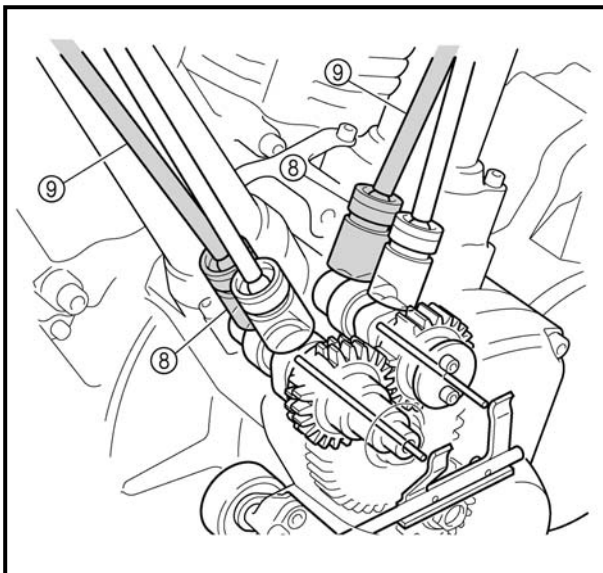

4. When the camshaft is rotated by the self-timing motor, the exhaust valve lifters ⑧ are lifted by the pin just before top dead center (TDC) and the exhaust valve push rod ⑨ and valve rocker arms are operated. Thus, opening the exhaust valve becomes easy.
5. When the engine starts and reaches a specific engine speed the decompression solenoid is turned off and the decompression system stops operating.



ENGINE SPECIFICATIONS

2

Item	Standard	Limit
<b>Engine</b>		
Engine type	Air-cooled, 4-stroke, OHV	----
Displacement	1,602 cm <sup>3</sup>	----
Cylinder arrangement	V-type 2-cylinder	----
Bore × stroke	95 × 113 mm (3.74 × 4.45 in)	----
Compression ratio	8.3:1	----
Engine idling speed	850 ~ 950 r/min	----
Vacuum pressure at engine idling speed	52 kPa (390 mm Hg, 15.4 in Hg)	----
Standard compression pressure (at sea level)	1,200 kPa (12.0 kgf/cm <sup>2</sup> , 171 psi) at 200 r/min	----
<b>Fuel</b>		
Recommended fuel	Unleaded fuel (for USA) Regular unleaded gasoline (for CDN)	----
Fuel tank capacity		
Total (including reserve)	20 L (17.6 Imp qt, 21.1 US qt)	----
Reserve only	3.5 L (3.08 Imp qt, 3.70 US qt)	----
<b>Engine oil</b>		
Lubrication system	Dry sump	----
Recommended oil		----
	Yamalube 4 (20W40) or SAE 20W40 type SE motor oil (40°F/5°C or above) (Non-Friction modified)	
Quantity		
Total amount	5.0 L (4.4 Imp qt, 5.3 US qt)	----
Without oil filter cartridge replacement	3.7 L (3.3 Imp qt, 3.9 US qt)	----
With oil filter cartridge replacement	4.1 L (3.6 Imp qt, 4.3 US qt)	----
Oil pressure (hot)	60 kPa (0.6 kgf/cm <sup>2</sup> , 8.5 psi) at 900 r/min	----
Relief valve opening pressure	0.60 MPa (6.0 kgf/cm <sup>2</sup> , 85 psi)	----
<b>Transfer gear oil</b>		
Recommended oil	SAE80API "GL-4" hypoid gear oil	----
Quantity	0.4 L (0.35 Imp qt, 0.42 US qt)	----
<b>Oil filter</b>		
Oil filter type	Cartridge (paper)	----
Bypass valve opening pressure	80 ~ 120 kPa (0.8 ~ 1.2 kgf/cm <sup>2</sup> , 11.3 ~ 17.1 psi)	----

# CHASSIS SPECIFICATIONS

**SPEC**

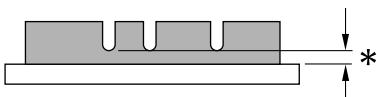
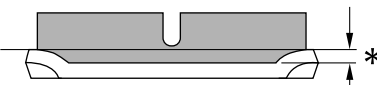

**2**

Item	Standard	Limit
<b>Rear tire</b>		
Tire type	With tube	----
Size	150/80 B16 71H	----
Model (manufacturer)	D404 (DUNLOP)/ G702 (BRIDGESTONE)	----
Tire pressure (cold)		
0 ~ 90 kg (0 ~ 198 lb)	250 kPa (2.5 kg/cm <sup>2</sup> , 36 psi)	----
90 kg (198 lb) ~ Maximum load*	280 kPa (2.8 kg/cm <sup>2</sup> , 40 psi)	----
High-speed riding	280 kPa (2.8 kg/cm <sup>2</sup> , 40 psi)	----
	* Load is the total weight of the cargo, rider, passenger and accessories.	
Min. tire tread depth	----	1.6 mm (0.06 in)
<b>Front brakes</b>		
Brake type	Dual-disc brake	----
Operation	Right-hand operation	----
Brake lever free play (lever end)	2 ~ 5 mm (0.08 ~ 0.20 in)	----
Recommended fluid	DOT 4	----
Brake discs		
Diameter × thickness	298 × 5 mm (11.7 × 0.20 in)	----
Min. thickness	----	4.5 mm (0.18 in)
Max. deflection	----	0.1 mm (0.004 in)
Brake pad lining thickness	6.0 mm (0.24 in)	0.5 mm (0.02 in)
		
Master cylinder inside diameter	15.8 mm (0.62 in)	----
Caliper cylinder inside diameter	30.1 mm (1.19 in) and 33.3 mm (1.31 in)	----
<b>Rear brake</b>		
Brake type	Single-disc brake	----
Operation	Right-foot operation	----
Brake pedal position (from the top of the brake pedal to the bottom of the rider footrest board)	100 mm (3.9 in)	----
Recommended fluid	DOT 4	----
Brake discs		
Diameter × thickness	320 × 7 mm (12.6 × 0.28 in)	----
Min. thickness	----	6.5 mm (0.26 in)
Max. deflection	----	0.1 mm (0.004 in)
Brake pad lining thickness	7.5 mm (0.30 in)	0.5 mm (0.02 in)
		

## TIGHTENING TORQUES

**SPEC**



Item	Thread size	Tightening torque			Remarks
		Nm	m·kgf	ft·lb	
Rear master cylinder and rear brake bracket	M8	23	2.3	17	
Rear brake reservoir tank	M6	4	0.4	2.9	
Union bolt (rear brake hose)	M10	30	3.0	22	
Footrest bracket and rear brake bracket	M8	16	1.6	11	
Footrest bracket and shift rod bracket	M8	16	1.6	11	
Front wheel axle	M18	78	7.8	56	
Front wheel axle pinch bolt	M8	19	1.9	13	
Rear wheel axle nut	M18	150	15.0	110	
Front brake caliper	M10	40	4.0	29	
Rear brake caliper	M10	40	4.0	29	
Brake disc and wheel	M8	23	2.3	17	
Caliper bleed screw	M8	6	0.6	4.3	
Driven pulley and rear wheel clutch hub	M12	95	9.5	68	
Rear brake caliper bracket and swingarm	M10	48	4.8	35	

**NOTE:**

1. First, tighten the ring nut to approximately 52 Nm (5.2 m · kg, 37 ft · lb) with a torque wrench, then loosen the ring nut completely.
2. Retighten the ring nut to specification.

2



EB206000

**CABLE ROUTING**

- ① Throttle cables
- ② Brake hose
- ③ Clutch cable
- ④ Left handlebar switch lead
- ⑤ Vacuum hose (air induction system)
- ⑥ Rear brake light switch lead
- ⑦ Rectifier/regulator

**A** Route the rear brake light switch lead in front of the rectifier/regulator bracket on the frame.

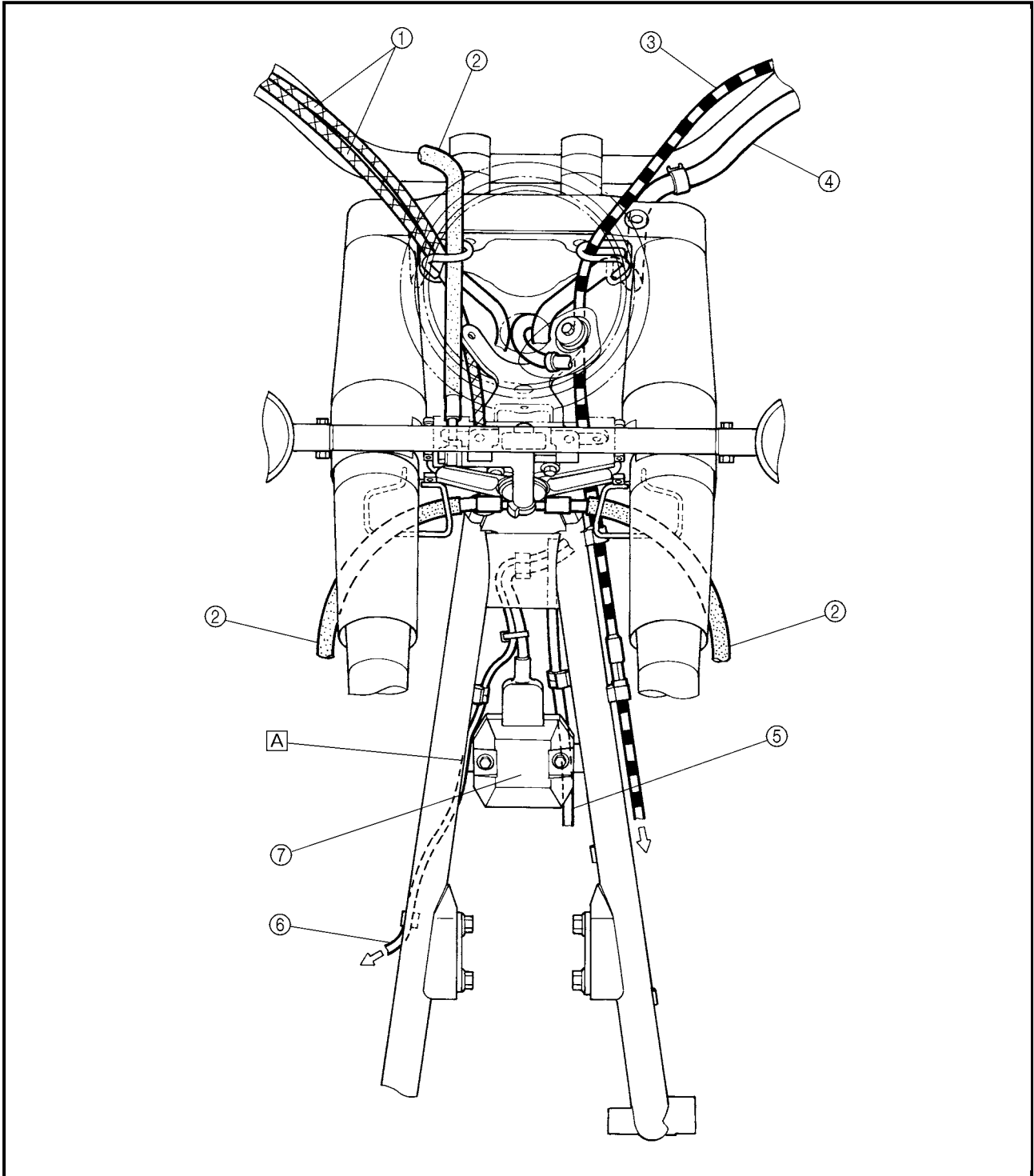
**2**

SEATS AND SIDE COVERS

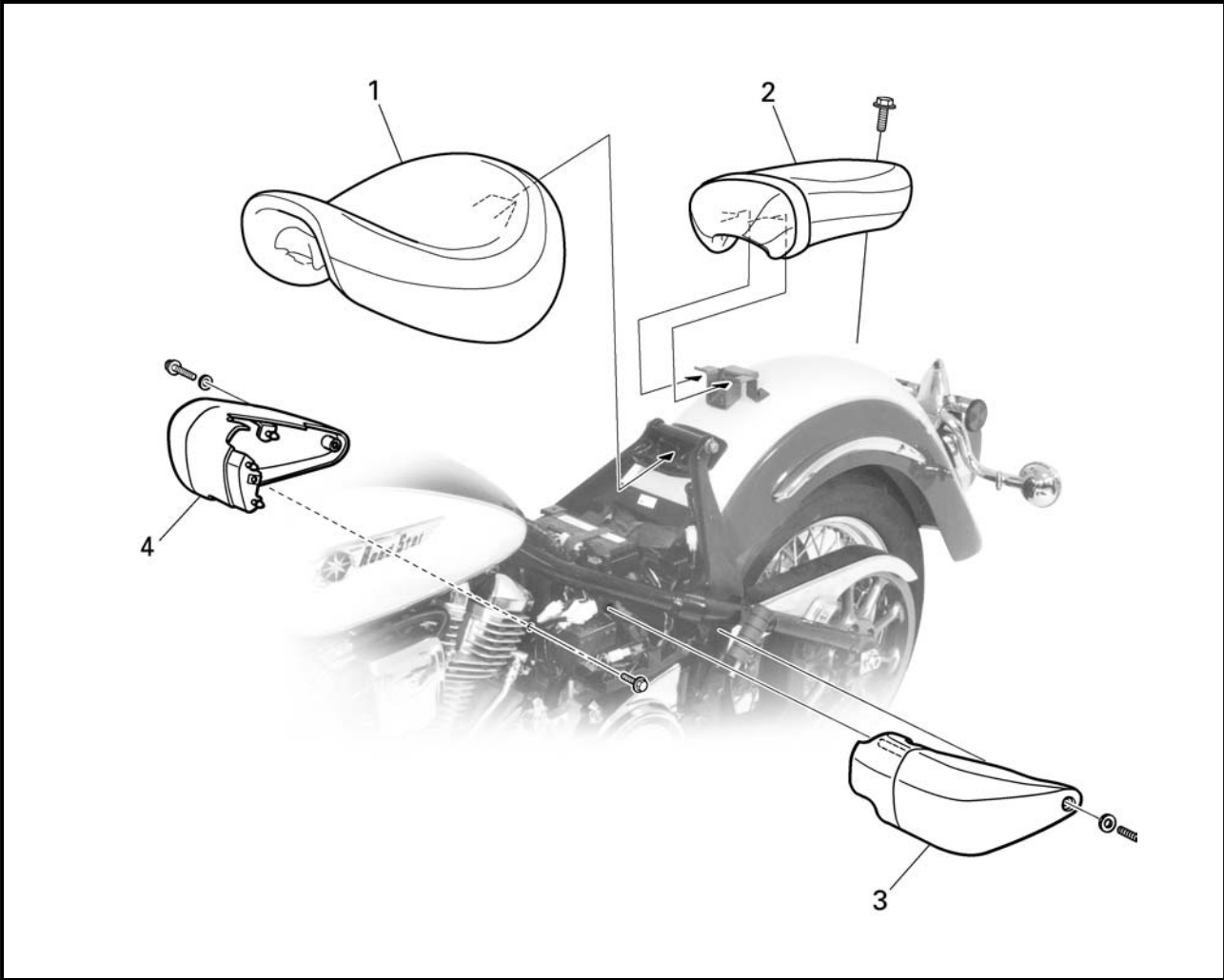

3

Order	Job/Part	Q'ty	Remarks
	<b>Removing the seats and side covers</b>		Remove the parts in the order listed.
1	Rider seat	1	
2	Passenger seat	1	
3	Left side cover	1	
4	Right side cover	1	
			For installation, reverse the removal procedure.



- c. Tighten the new oil filter cartridge to specification with an oil filter wrench.

	<b>Oil filter cartridge</b> <b>17 Nm (1.7 m · kg, 12 ft · lb)</b>
---	--



- 6. Check:
  - engine oil drain bolt gasket  
Damage → Replace.

- 7. Install:
  - engine oil drain bolt

	<b>43 Nm (4.3 m · kg, 31 ft · lb)</b>
---	---------------------------------------

- 8. Fill:
  - oil tank  
(with the specified amount of the recommended engine oil)

	<b>Quantity</b> <b>Total amount</b> <b>5.0 L (4.4 Imp qt, 5.3 US qt)</b> <b>Periodic oil replacement</b> <b>3.7 L (3.3 Imp qt, 3.9 US qt)</b> <b>With oil filter cartridge replacement</b> <b>4.1 L (3.6 Imp qt, 4.3 US qt)</b>
---	---

**NOTE:** \_\_\_\_\_

- Pour the engine oil in several stages.
- First, pour in 2.5 L (2.2 Imp qt, 2.6 US qt) of oil, and then start the engine and rev it 3 to 5 times. Stop the engine, and then pour in the remainder of the specified amount.

**CAUTION:** \_\_\_\_\_

**When starting the engine make sure the dipstick is securely fitted into the oil tank.**

- 9. Fill: (when the engine is disassembled)
  - crankcase and oil tank

	<b>Quantity</b> <b>Total amount</b> <b>5.0 L (4.4 Imp qt, 5.3 US qt)</b> <b>Oil tank</b> <b>2.0 L (1.8 Imp qt, 2.1 US qt)</b> <b>Crankcase</b> <b>3.0 L (2.6 Imp qt, 3.2 US qt)</b>
---	---

**3**



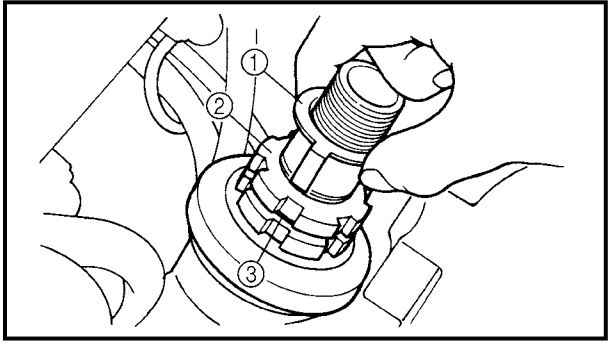

3

d. Check the steering head for looseness or binding by turning the front fork all the way in both directions. If any binding is felt, remove the lower bracket and check the upper and lower bearings.

Refer to "STEERING HEAD" in chapter 4.

- e. Install the rubber washer ③.
- f. Install the upper ring nut ②.
- g. Finger tighten the upper ring nut ②, then align the slots of both ring nuts. If necessary, hold the lower ring nut and tighten the upper ring nut until their slots are aligned.
- h. Install the lock washer ①.

**NOTE:** \_\_\_\_\_  
Make sure the lock washer tabs sit correctly in the ring nut slots.



- 7. Install:
  - upper bracket
  - washer
  - steering stem nut

 130 Nm (13.0 m · kg, 94 ft · lb)

- 8. Tighten:
  - upper bracket pinch bolt

 10 Nm (1.0 m · kg, 7.2 ft · lb)

- 9. Install:
  - meter assembly
 Refer to "FUEL TANK".

EAS00149  
**CHECKING THE FRONT FORK**

- 1. Stand the motorcycle on a level surface.

**⚠ WARNING** \_\_\_\_\_

**Securely support the motorcycle so that there is no danger of it falling over.**

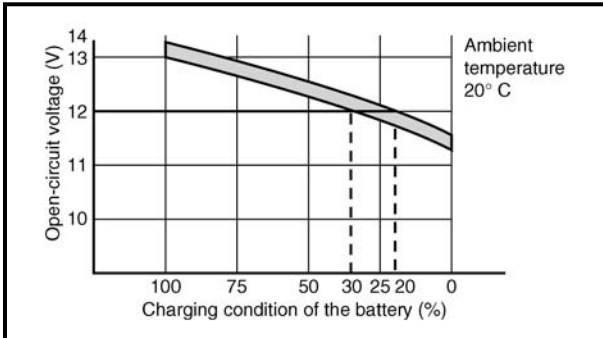
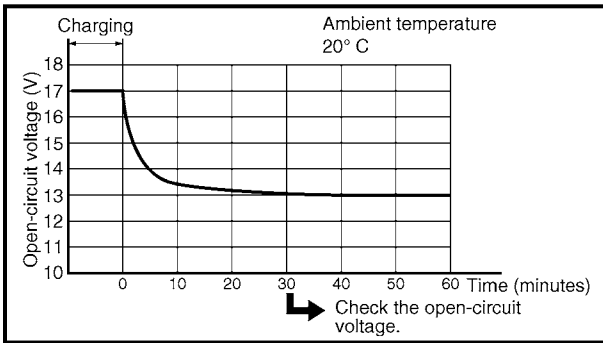

## 5. Charge:

- battery  
(refer to the appropriate charging method illustration)

### ⚠ WARNING

**Do not quick charge a battery.**

### CAUTION:

- Never remove the MF battery sealing caps.
- Do not use a high-rate battery charger since it forces a high-amperage current into the battery quickly and can cause battery overheating and battery plate damage.
- If it is impossible to regulate the charging current on the battery charger, be careful not to overcharge the battery.
- When charging a battery, be sure to remove it from the motorcycle. (If charging has to be done with the battery mounted on the motorcycle, disconnect the negative battery lead from the battery terminal.)
- To reduce the chance of sparks, do not plug in the battery charger until the battery charger leads are connected to the battery.
- Before removing the battery charger lead clips from the battery terminals, be sure to turn off the battery charger.
- Make sure the battery charger lead clips are in full contact with the battery terminals and that they are not shorted. A corroded battery charger lead clip may generate heat in the contact area and a weak clip spring may cause sparks.
- If the battery becomes hot to the touch at any time during the charging process, disconnect the battery charger and let the battery cool before reconnecting it. Hot batteries can explode!
- As shown in the following illustration, the open-circuit voltage of an MF battery stabilizes about 30 minutes after charging has been completed. Therefore, wait 30 minutes after charging is completed before measuring the open-circuit voltage.

3



## CONTENTS

### CHASSIS

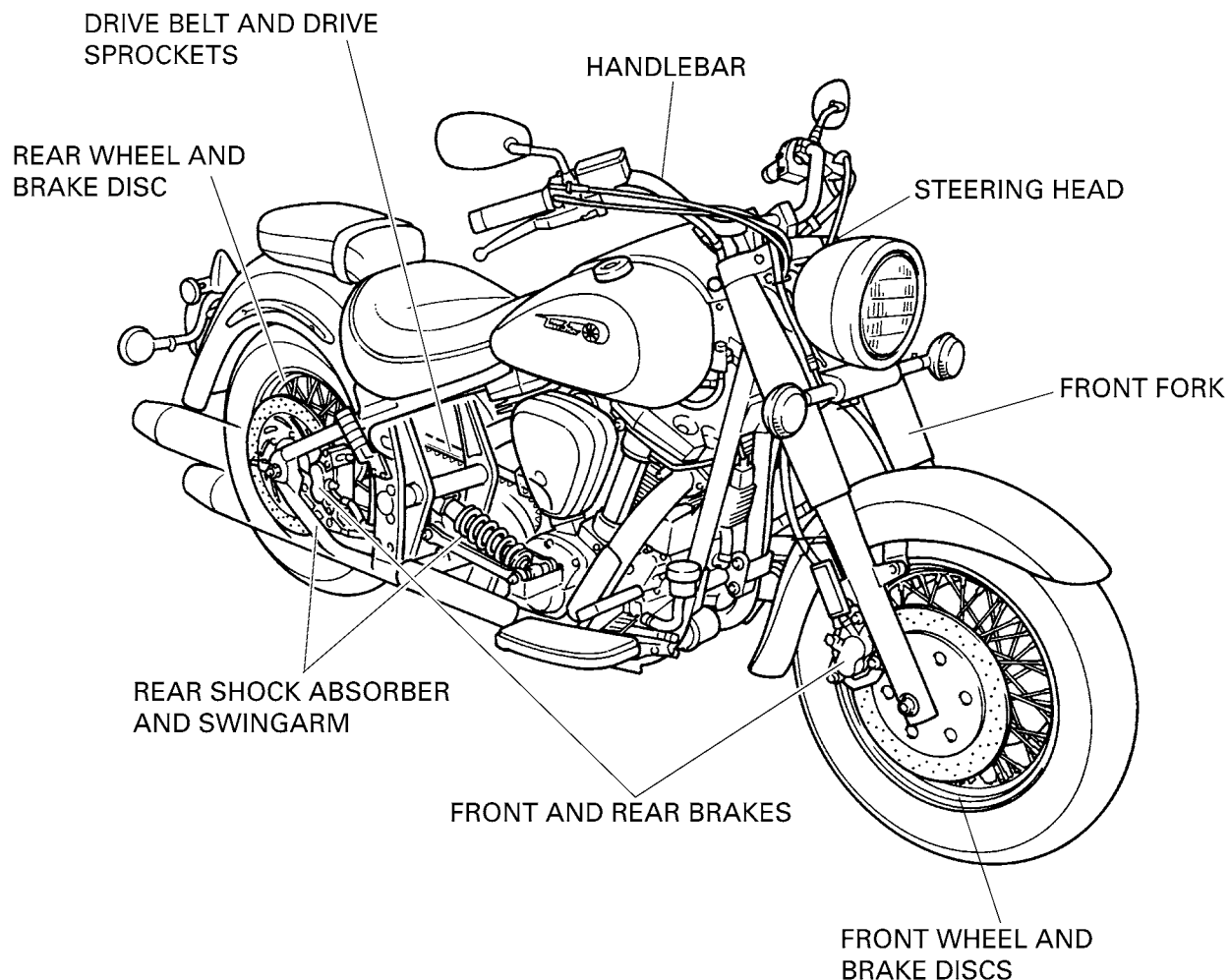

4

<b>FRONT WHEEL AND BRAKE DISCS</b> .....	4-1
REMOVING THE FRONT WHEEL .....	4-3
DISASSEMBLING THE FRONT WHEEL .....	4-3
CHECKING THE FRONT WHEEL .....	4-4
CHECKING THE BRAKE DISCS .....	4-6
ASSEMBLING THE FRONT WHEEL .....	4-7
INSTALLING THE FRONT WHEEL .....	4-7
ADJUSTING THE FRONT WHEEL STATIC BALANCE .....	4-9
<b>REAR WHEEL, BRAKE DISC AND REAR WHEEL PULLEY</b> .....	4-11
REMOVING THE REAR WHEEL .....	4-16
CHECKING THE REAR WHEEL .....	4-16
CHECKING THE REAR WHEEL DRIVE HUB .....	4-17
CHECKING AND REPLACING THE REAR WHEEL PULLEY .....	4-17
ASSEMBLING THE REAR WHEEL .....	4-18
INSTALLING THE REAR WHEEL .....	4-18
ADJUSTING THE REAR WHEEL STATIC BALANCE .....	4-21

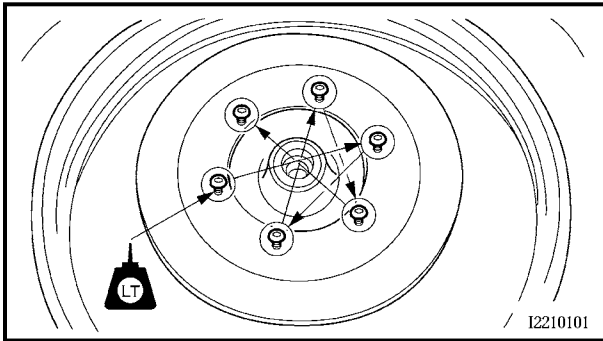

2. Install:
  - brake discs
  - brake disc covers

**23 Nm (2.3 m · kg, 17 ft · lb)**

**NOTE:**

- Apply locking agent (LOCTITE® 648) to the threads of the brake disc bolts.
- Tighten the brake disc bolts in stages and in a crisscross pattern.

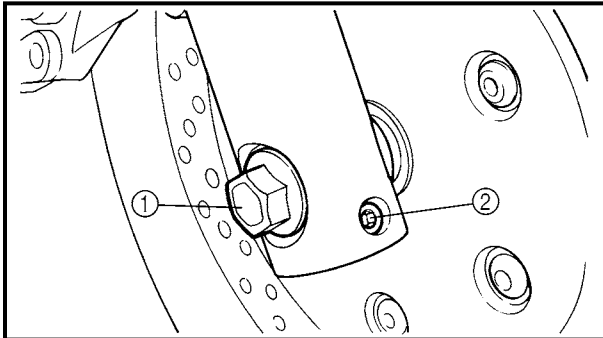

3. Install:
  - collars
  - front wheel
  - front wheel axle

4. Tighten:
  - front wheel axle ①

**78 Nm (7.8 m · kg, 56 ft · lb)**

- wheel axle pinch bolt ②

**20 Nm (2.0 m · kg, 14 ft · lb)**

**CAUTION:**

**Before tightening the wheel axle nut, push down hard on the handlebar several times and check if the front fork rebounds smoothly.**

**4**

5. Install:
  - brake calipers

**40 Nm (4.0 m · kg, 29 ft · lb)**

**⚠ WARNING**

**Make sure the brake hose is routed properly.**

6. Install:
  - reflectors

 **Rear wheel pulley self-locking nut**  
95 Nm (9.5 m • kg, 68 ft • lb)

**NOTE:** \_\_\_\_\_  
Tighten the self-locking nuts in stages and in a crisscross pattern.



**ASSEMBLING THE REAR WHEEL**

- 1. Install:
  - bearings
  - spacer
  - bearing
  - oil seal **New**

Refer to "FRONT WHEEL AND BRAKE DISCS".

EAS00572  
**INSTALLING THE REAR WHEEL**

- 1. Lubricate:
  - oil seal lips

 **Recommended lubricant**  
Lithium soap base grease

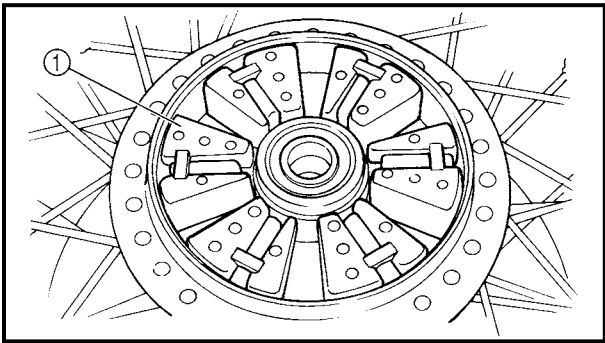

- 2. Install:
  - rear wheel drive hub dampers ①

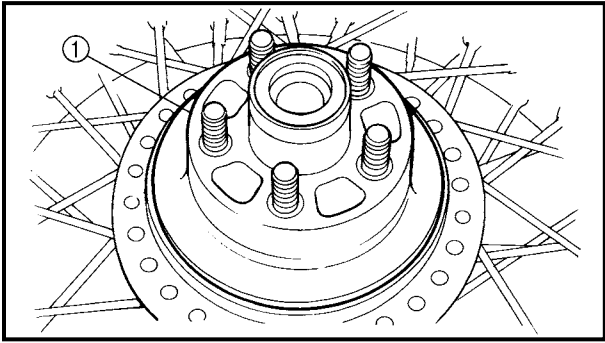

- 3. Install:
  - rear wheel drive hub assembly ①

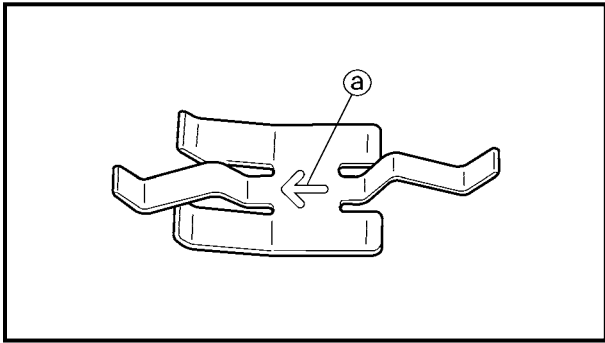

- b. Loosen the bleed screw and push the brake caliper pistons into the brake caliper with your finger.
- c. Tighten the bleed screw.

	<p><b>Bleed screw</b>  <b>6 Nm (0.6 m · kg, 4.3 ft · lb)</b></p>
---	--

- d. Install new brake pads and a new brake pad spring.

**NOTE:** \_\_\_\_\_  
 The arrow Ⓐ on the brake pad spring must point in the direction of disc rotation.



- 6. Install:
  - brake pad pins
  - brake pad clips
  - brake pad cover
  - brake caliper

	<p><b>40 Nm (4.0 m · kg, 29 ft · lb)</b></p>
---	--

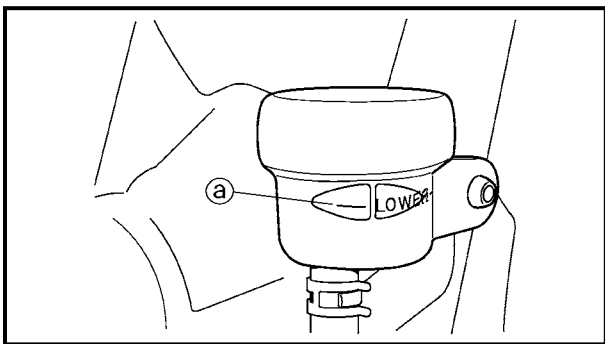

- 7. Check:
  - brake fluid level  
 Below the minimum level mark Ⓐ → Add the recommended brake fluid to the proper level.  
 Refer to “CHECKING THE BRAKE FLUID LEVEL” in chapter 3.

- 8. Check:
  - brake pedal operation  
 Soft or spongy feeling → Bleed the brake system.  
 Refer to “BLEEDING THE HYDRAULIC BRAKE SYSTEM” in chapter 3.

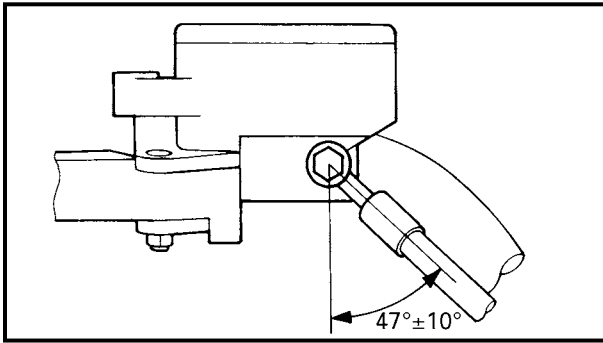

4. Install:

- copper washers **New**
- brake hose
- union bolt 30 Nm (3.0 m · kg, 22 ft · lb)

**⚠ WARNING**

Proper brake hose routing is essential to insure safe motorcycle operation. Refer to "CABLE ROUTING".

**NOTE:**

- While holding the brake hose, tighten the union bolt as shown.
- Turn the handlebar to the left and to the right to make sure the brake hose does not touch other parts (e.g., wire harness, cables, leads). Correct if necessary.

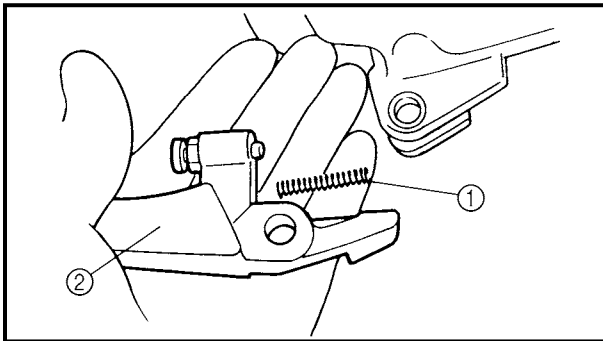

5. Install:

- brake lever spring ①
- brake lever ②

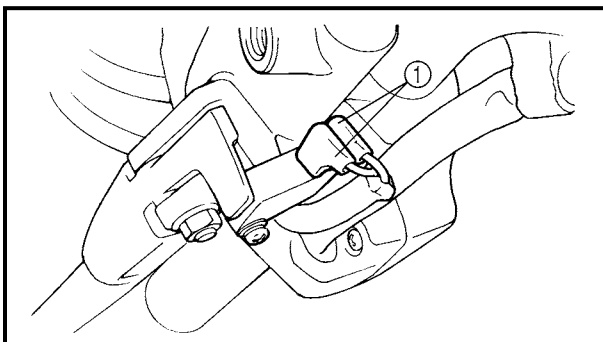

6. Connect:

- front brake light switch connectors ①

7. Fill:

- brake master cylinder reservoir (with the specified amount of the recommended brake fluid)

	<b>Recommended brake fluid DOT 4</b>
--	--



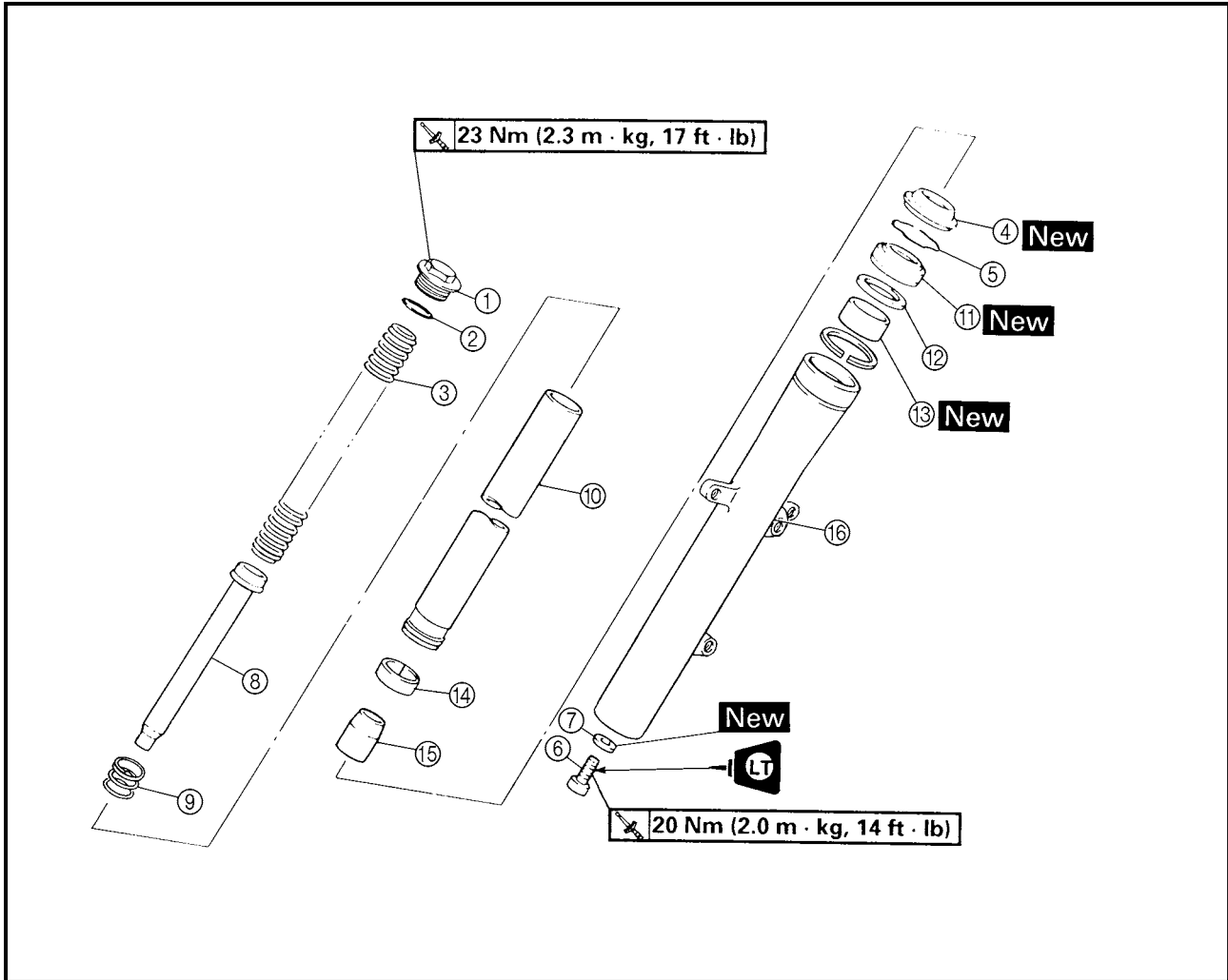

4

Order	Job/Part	Q'ty	Remarks
⑪	Oil seal	1	For assembly, reverse the disassembly procedure.
⑫	Seal spacer	1	
⑬	Outer tube bushing	1	
⑭	Inner tube bushing	1	
⑮	Oil flow stopper	1	
⑯	Outer tube	1	

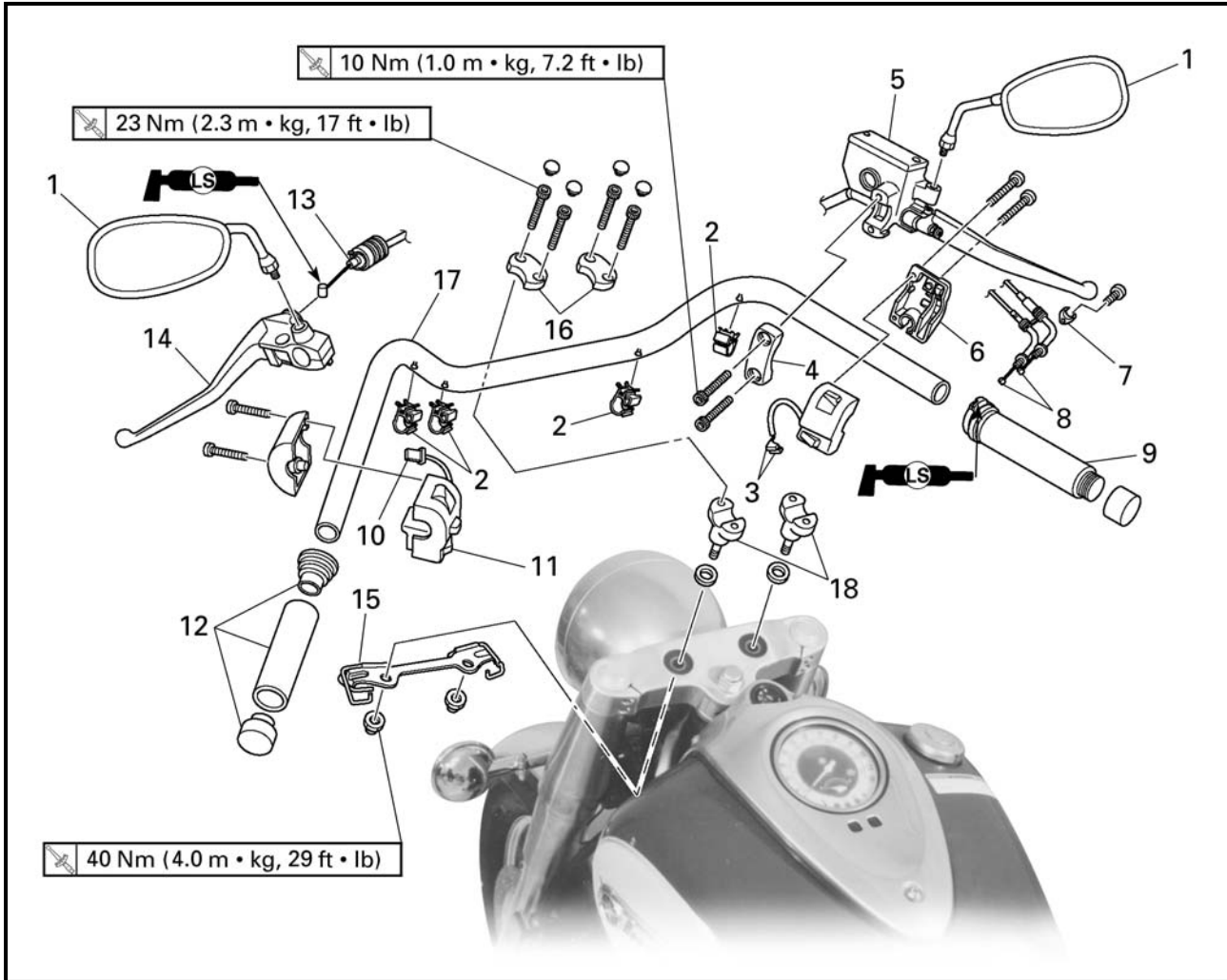

4

Order	Job/Part	Q'ty	Remarks
11	Left handlebar switch	1	
12	Handlebar grip	1	
13	Clutch cable	1	Disconnect.
14	Clutch lever holder	1	
15	Cable guide	1	
16	Upper handlebar holder	2	
17	Handlebar	1	
18	Lower handlebar holder	2	
			For installation, reverse the removal procedure.

**10.Install:**

- upper bracket
  - steering stem nut
  - front fork legs
- Refer to "FRONT FORK".

**11.Install:**

- handlebar
- Refer to "HANDLEBAR".
- front fork legs
- Refer to "FRONT FORK".
- meter assembly
- Refer to "FUEL TANK" in chapter 3.

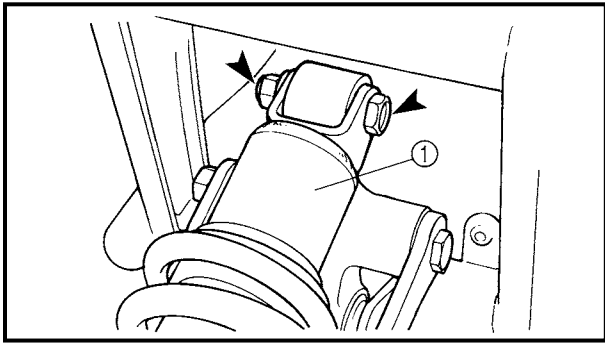

8. Install:
- rear shock absorber ①  
(onto the relay arm)

40 Nm (4.0 m · kg, 29 ft · lb)

9. Install:
- rear shock absorber and swingarm assembly
  - pivot shaft
  - washer
  - pivot shaft nut

125 Nm (12.5 m · kg, 90 ft · lb)

- covers

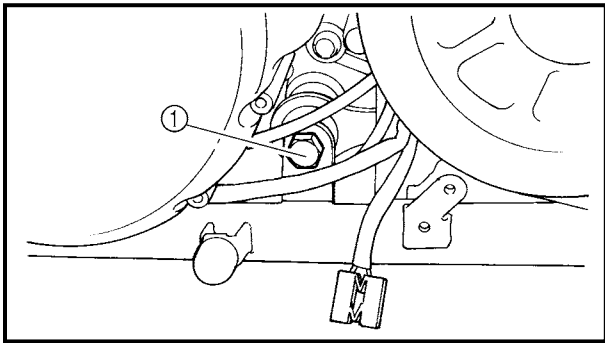

10. Install:
- bolt (shock absorber - connecting arm - frame) ①

**NOTE:** \_\_\_\_\_  
When installing the bolt (shock absorber - connecting arm - frame), hold the swingarm so that it does not drop down.  
\_\_\_\_\_

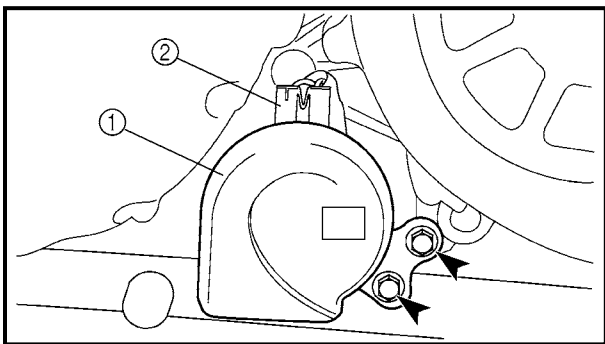

11. Install:
- horn ①
12. Connect:
- horn coupler ②

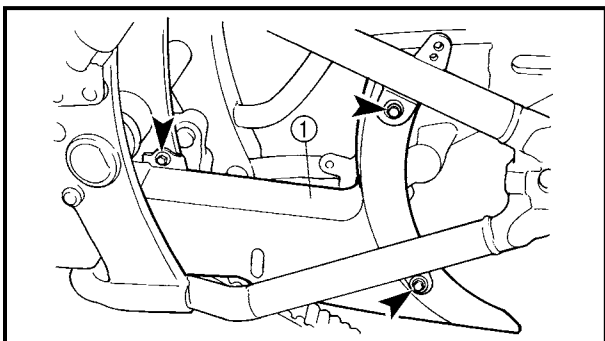

13. Install:
- lower drive belt cover ①

CLICK HERE TO **DOWNLOAD** THE COMPLETE MANUAL

- Thank you very much for reading the preview of the manual.
- You can download the complete manual from: [www.heydownloads.com](http://www.heydownloads.com) by clicking the link below



- Please note: If there is no response to CLICKING the link, please download this PDF first and then click on it.

CLICK HERE TO **DOWNLOAD** THE COMPLETE MANUAL



EAS00188

## ENGINE

## ENGINE

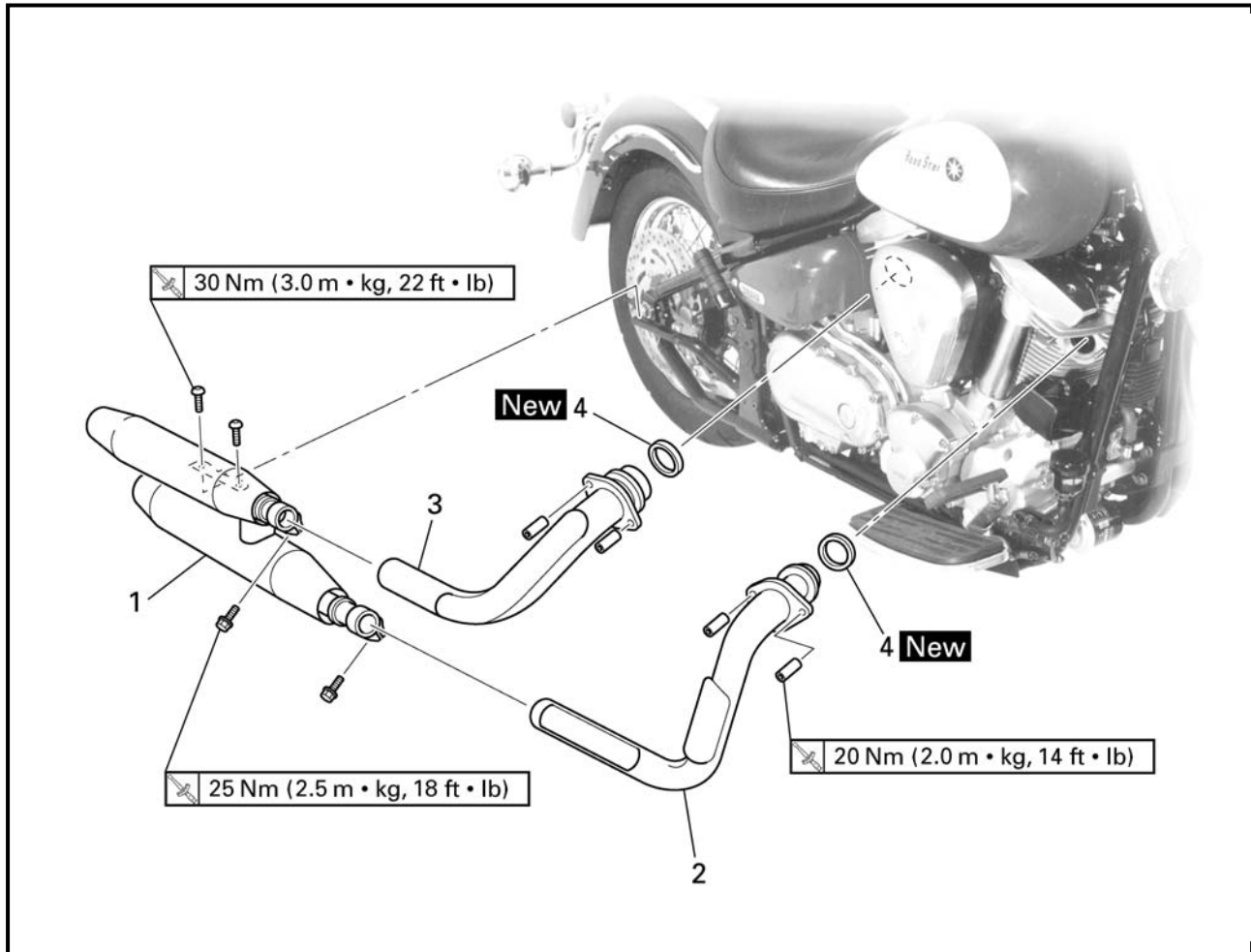

Order	Job/Part	Q'ty	Remarks
	<b>Removing the muffler and exhaust pipes</b>		Remove the parts in the order listed.
1	Muffler	1	
2	Front exhaust pipe	1	
3	Rear exhaust pipe	1	
4	Gasket	2	
			For installation, reverse the removal procedure.



## 18.Install:

- starter motor  
Refer to "STARTER MOTOR" in chapter 7.
- air induction system parts  
Refer to "AIR INDUCTION SYSTEM" in chapter 6.
- carburetor joint
- carburetor  
Refer to "CARBURETOR" in chapter 6.
- air filter case  
Refer to "AIR FILTER CASE" in chapter 3.
- fuel tank  
Refer to "FUEL TANK" in chapter 3.
- side covers
- rider seat  
Refer to "SEATS AND SIDE COVERS" in chapter 3.

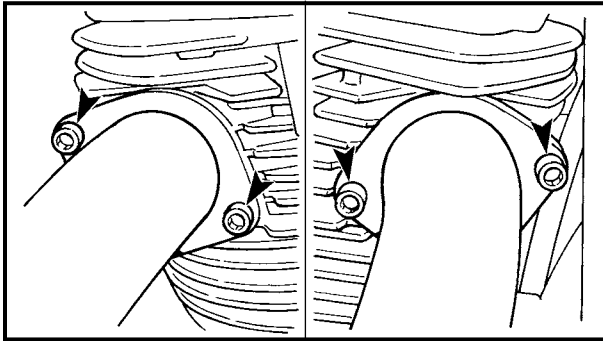

## 19.Install:

- gaskets
- exhaust pipes

**NOTE:**

Finger tighten the exhaust pipe nuts.

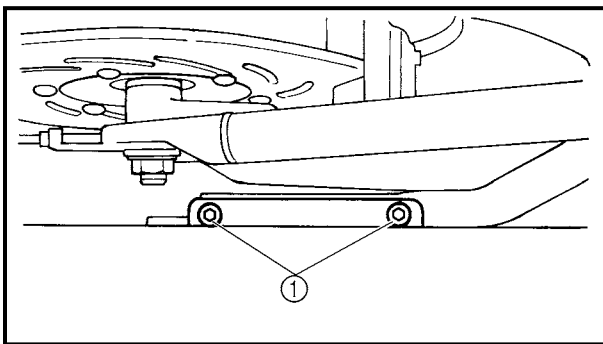

## 20.Install:

- muffler
- bolts ①

 30 Nm (3.0 m · kg, 22 ft · lb)

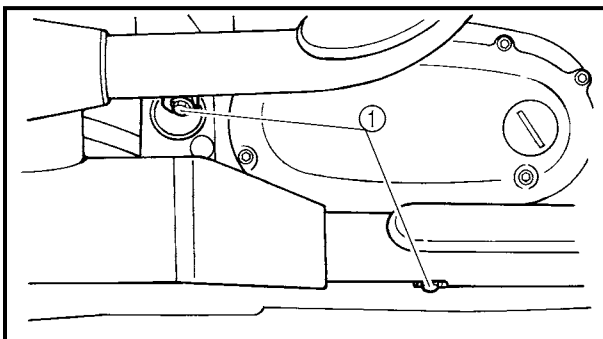

## 21.Tighten:

- exhaust pipe nuts

 20 Nm (2.0 m · kg, 14 ft · lb)

- clamp bolts ①

 25 Nm (2.5 m · kg, 18 ft · lb)

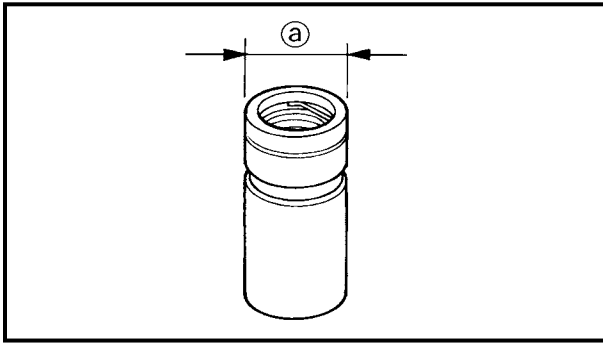

## 3. Measure:

- valve lifter outside diameter (a)
- Out of specification → Replace.



**Valve lifter case outside diameter**  
 22.9680 ~ 22.9744 mm  
 (0.9043 ~ 0.9045 in)

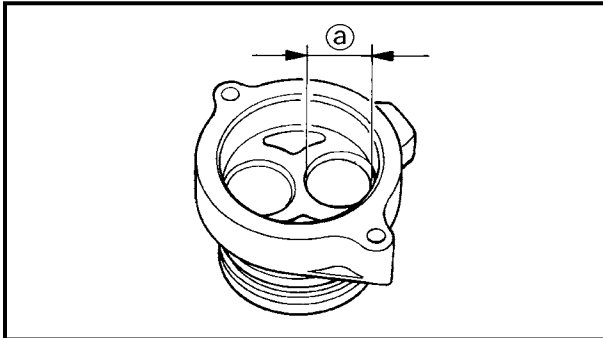

## 4. Measure:

- valve lifter case inside diameter (a)
- Out of specification → Replace.



**Valve lifter case inside diameter**  
 22.990 ~ 23.010 mm  
 (0.9051 ~ 0.9059 in)

## 5. Calculate:

- valve lifter-to-valve lifter case clearance

**NOTE:**

Calculate the clearance by subtracting the valve lifter case outside diameter.

Above 0.072 mm (0.0028 in) → Replace the defective part(s)



**Valve lifter-to-valve lifter case clearance**  
 0.0156 ~ 0.042 mm  
 (0.0006 ~ 0.0017 in)

**BLEEDING A VALVE LIFTER**

A valve lifter must be bled in the following cases.

- When installing a new valve lifter
- When the valve lifter leaks oil

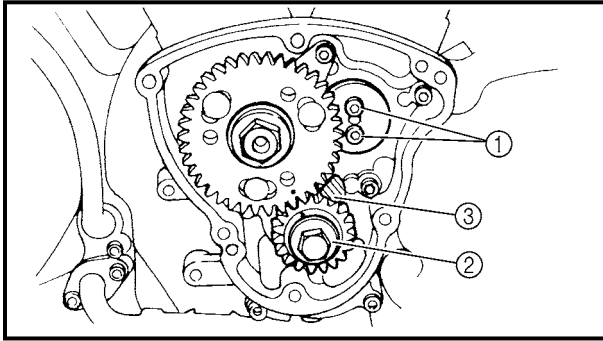

## REMOVING THE CAMSHAFTS

### 1. Loosen:

- front cylinder camshaft end cover bolts ①
- camshaft drive gear bolt ②

### NOTE:

- Place a folded copper washer ③ between the teeth of the camshaft drive gear and camshaft driven gear in order to lock them.
- Do not damage the teeth of the camshaft drive and camshaft driven gears.

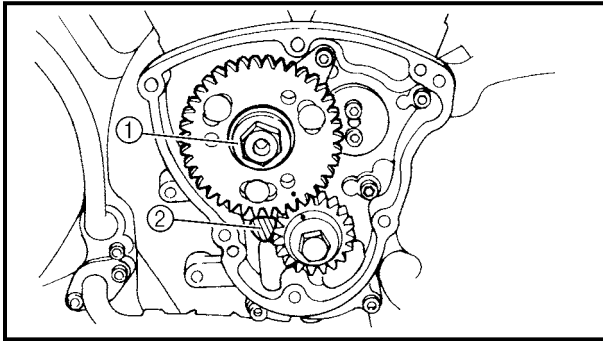

### 2. Loosen:

- camshaft driven gear nut ①

### NOTE:

- Place a folded copper washer ② between the teeth of the camshaft drive gear and camshaft driven gear in order to lock them.
- Do not damage the teeth of the camshaft drive and camshaft driven gears.

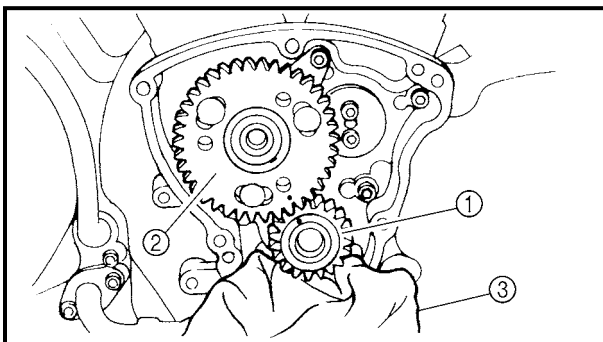

### 3. Remove:

- front cylinder camshaft end cover
- camshaft drive gear ①
- camshaft driven gear ②
- straight keys

### NOTE:

Cover the crankcase hole with a clean rag ③ to prevent the straight keys from falling into the crankcase.

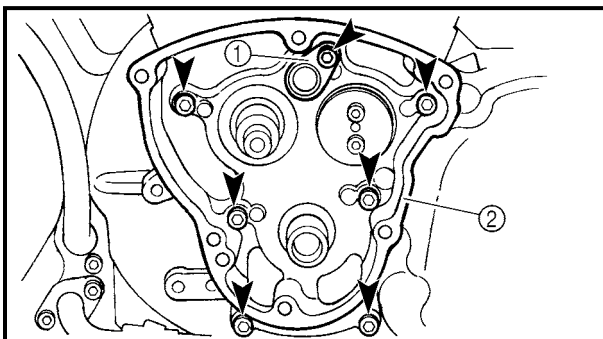

### 4. Remove:

- oil delivery pipe ①
- camshaft cover ②  
(along with the camshafts)

### NOTE:

Loosen each bolt 1/4 of a turn at a time, in stages and in a crisscross pattern. After all of the bolts are fully loosened, remove them.



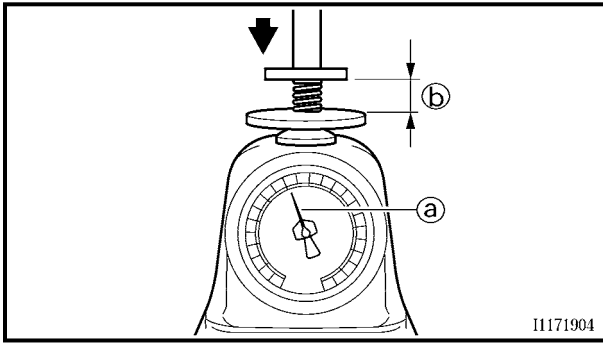

2. Measure:

- compressed valve spring force (a)  
Out of specification → Replace the valve spring.

(b) Installed length



**Compressed valve spring force (installed)**

**Intake and exhaust inner valve spring**

6.3 ~ 7.3 kg at 29.0 mm  
(13.9 ~ 16.1 lb at 1.14 in)

**Intake and exhaust outer valve spring**

13.9 ~ 16.1 kg at 31.0 mm  
(30.6 ~ 35.5 lb at 1.22 in)

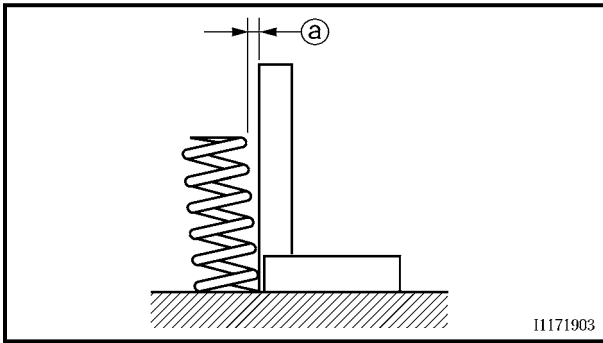

3. Measure:

- valve spring tilt (a)  
Out of specification → Replace the valve spring.



**Maximum valve spring tilt**

**Intake and exhaust inner valve spring**

2.4 mm (0.094 in)

**Intake and exhaust outer valve spring**

2.4 mm (0.094 in)

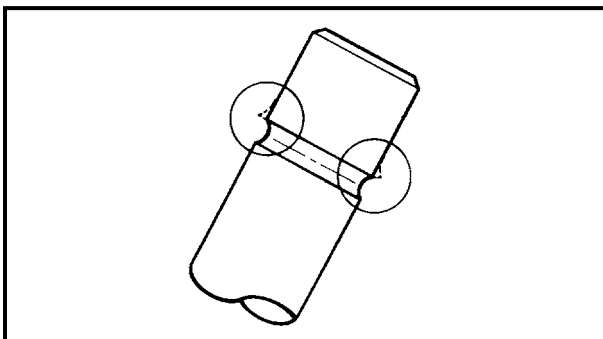

EAS00246

**INSTALLING THE VALVES**

The following procedure applies to all of the valves and related components.

1. Deburr:

- valve stem end  
(with an oil stone)

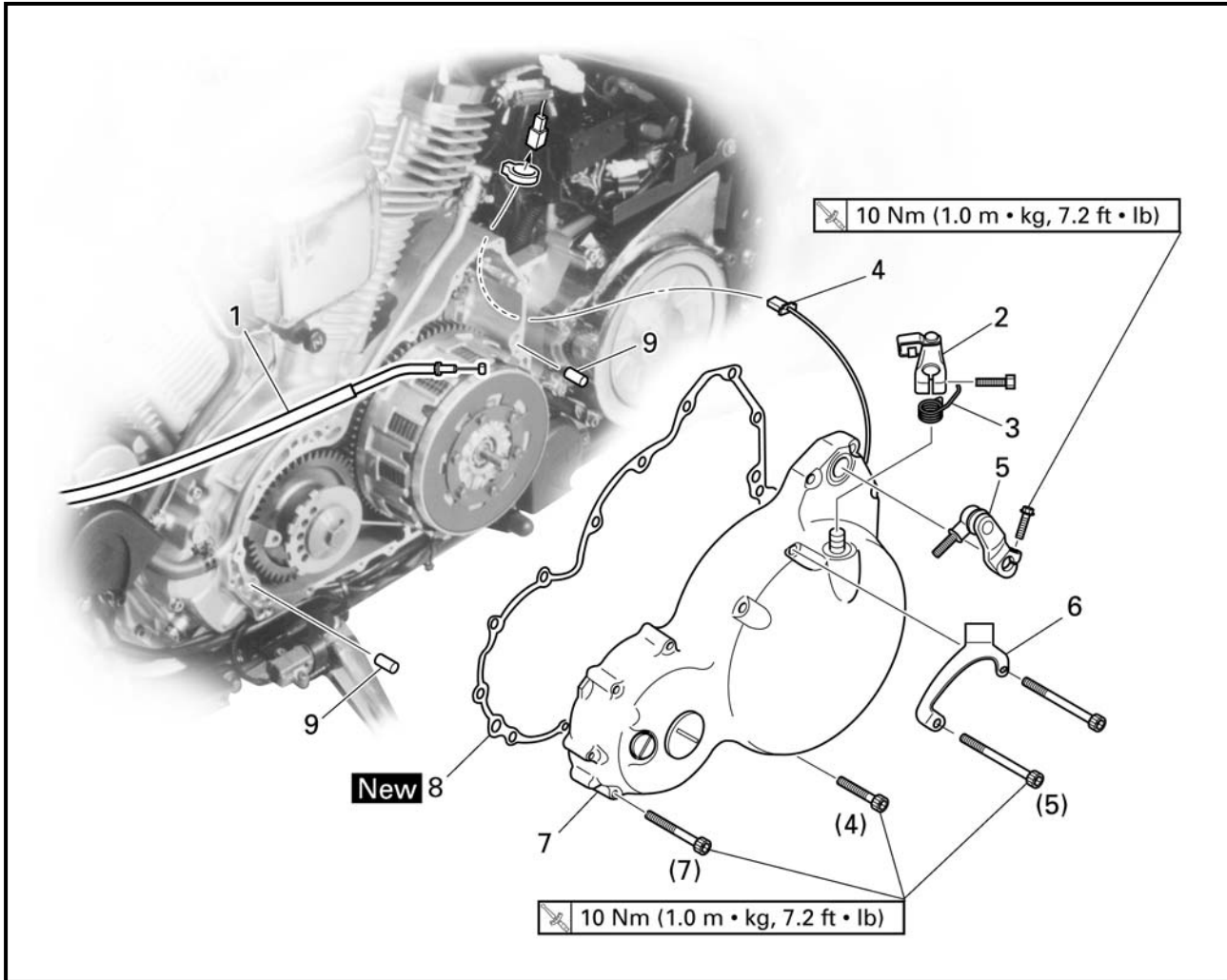

5

Order	Job/Part	Q'ty	Remarks
8	Clutch cover gasket	1	For installation, reverse the removal procedure.
9	Dowel pin	1	



**Universal clutch holder  
YM-91042**

5. Bend the lock washer tab along a flat side of the nut.
6. Lubricate:
  - friction plates
  - clutch plates  
(with the recommended lubricant)



**Recommended lubricant  
Engine oil**

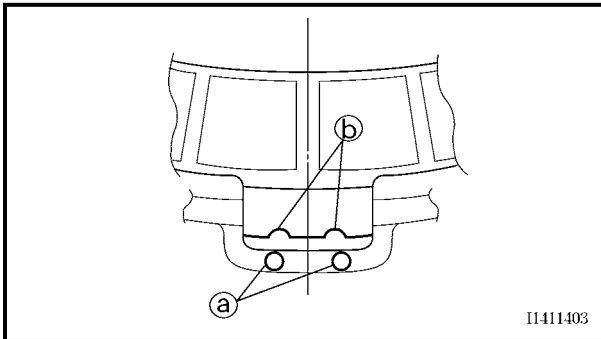

7. Install:
  - friction plates
  - clutch plates

**NOTE:** \_\_\_\_\_

- First, install a friction plate and then alternate between a clutch plate and a friction plate.
- Align the two embossed mark (a) on the clutch housing with the two semicircular slots (b) in the friction plates.

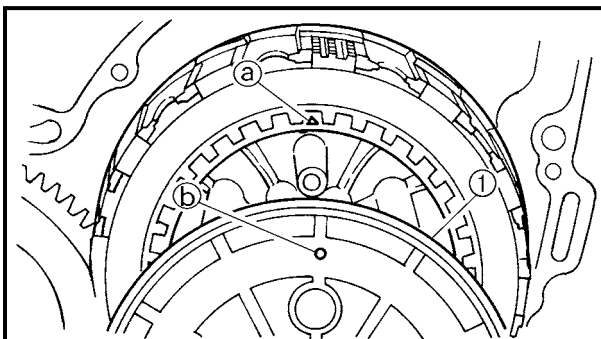

8. Install:
  - pressure plate ①

**NOTE:** \_\_\_\_\_

- Align the punch mark (a) on the pressure plate with the punch mark (b) on the clutch boss.



- c. When turning the starter clutch gear counterclockwise [B], it should turn freely, otherwise the starter clutch is faulty and must be replaced.

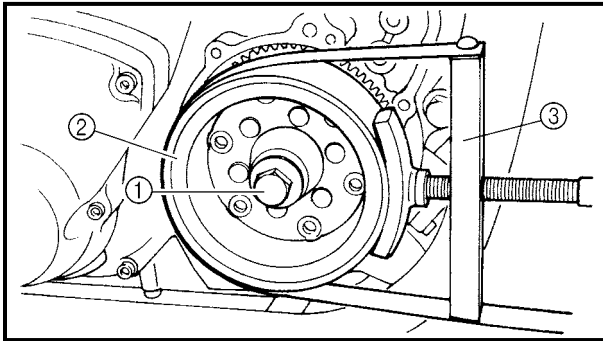
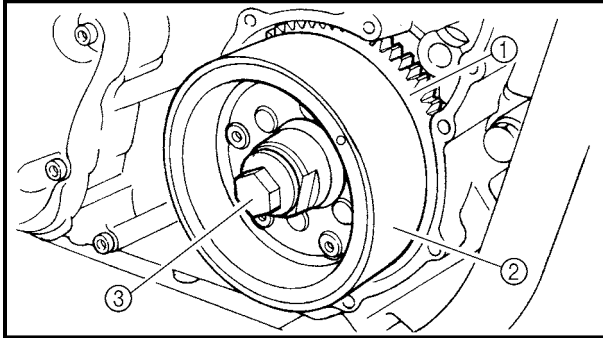

EAS00354

**INSTALLING THE GENERATOR**

1. Install:
  - starter clutch gear ①
  - generator rotor ②
  - washer
  - generator rotor bolt ③

**NOTE:** \_\_\_\_\_  
Clean the tapered portion of the crankshaft and the generator rotor hub.

2. Tighten:
  - generator rotor bolt ①

**160 Nm (16.0 m · kg, 115 ft · lb)**

**NOTE:** \_\_\_\_\_  
While holding the generator rotor ② with the sheave holder ③, tighten the generator rotor bolt.

	<b>Sheave holder</b> <b>YS-01880</b>
--	---

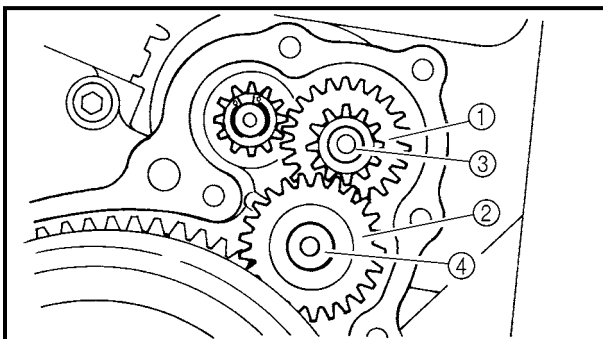

3. Install:
  - starter clutch idle gear #1 ①
  - starter clutch idle gear #2 ②
  - starter clutch idle gear shaft #1 ③
  - starter clutch idle gear shaft #2 ④

**5**

**REMOVING THE BATTERY**

1. Disconnect:
  - battery leads  
(from the battery terminals)

**⚠ WARNING**

**First, disconnect the negative battery lead, then the positive battery lead.**

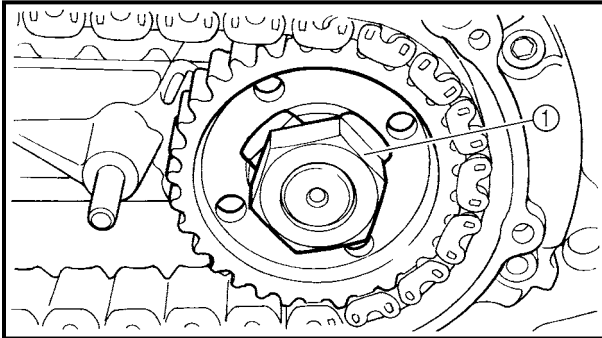
**REMOVING THE MIDDLE DRIVEN SHAFT****NOTE:**

Loosen the middle drive gear nut before removing the drive pulley.

1. Straighten the lock washer tab.
2. Loosen:
  - middle drive gear nut ①

**NOTE:**

When loosening the middle drive gear nut, press down on the brake pedal so the middle drive gear does not move.

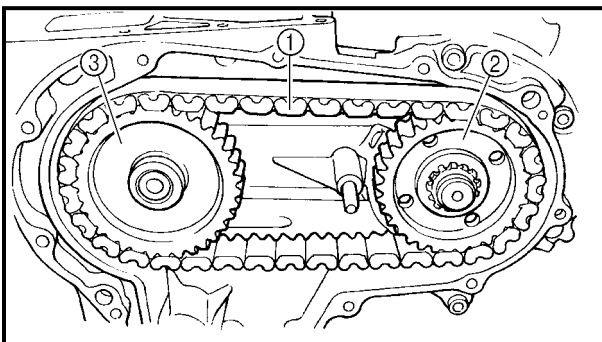
**3. Remove:**

- primary chain ①
- middle drive gear ②
- middle driven shaft ③

**NOTE:**

Remove the primary chain, middle drive gear and middle driven shaft at the same time.

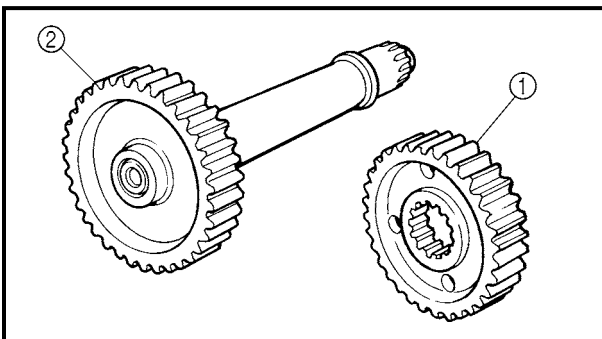
**CHECKING THE MIDDLE DRIVE****1. Check:**

- middle drive gear ①
- middle driven gear ②

Damage/wear → Replace the middle drive gear, middle driven shaft and primary chain as a set.

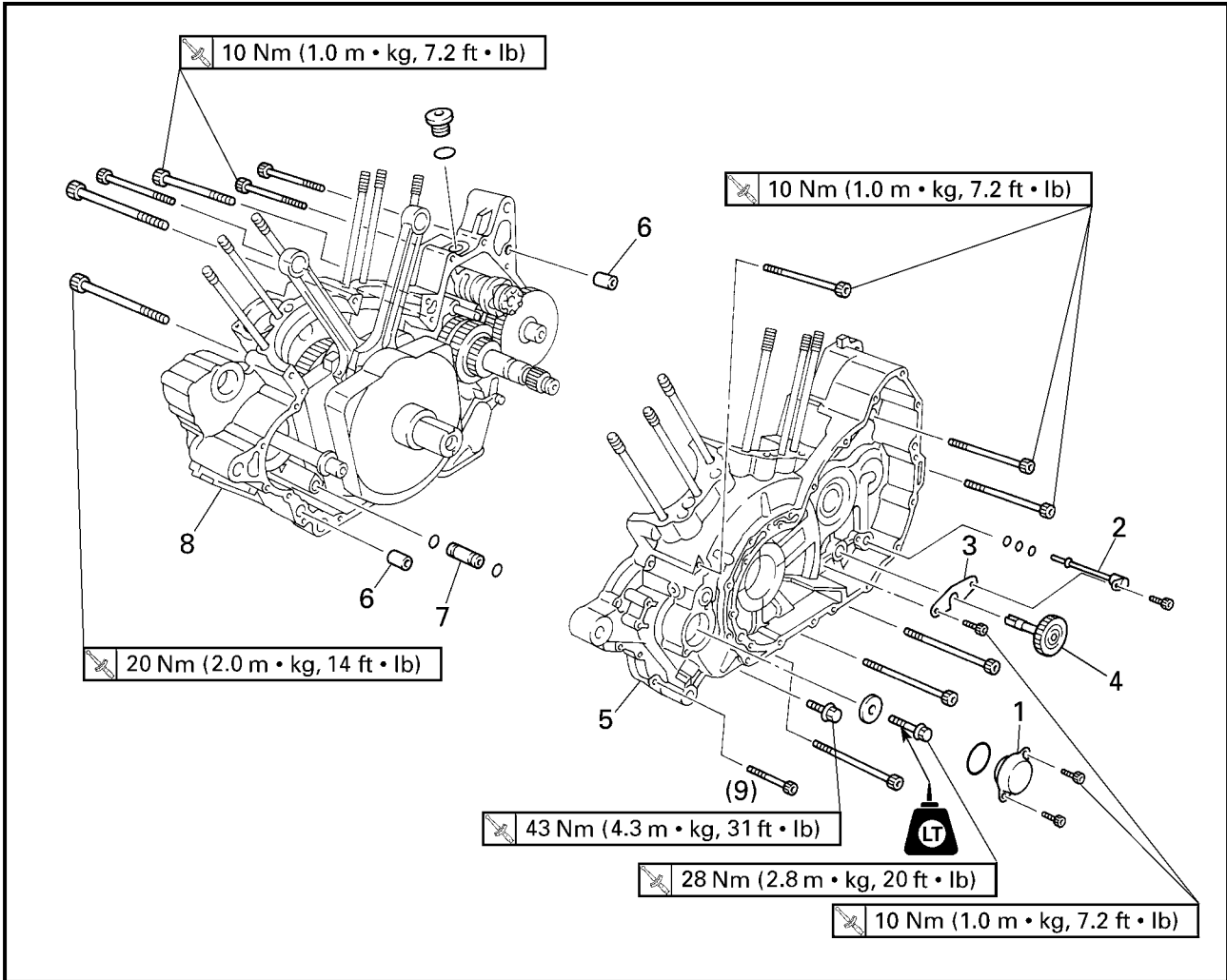

5

Order	Job/Part	Q'ty	Remarks
4	Engine oil pump driven gear	1	For installation, reverse the removal procedure.
5	Left crankcase	1	
6	Dowel	2	
7	Joint pipe	1	
8	Right crankcase	1	

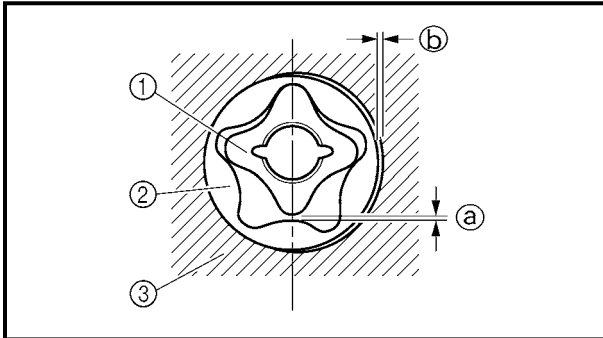
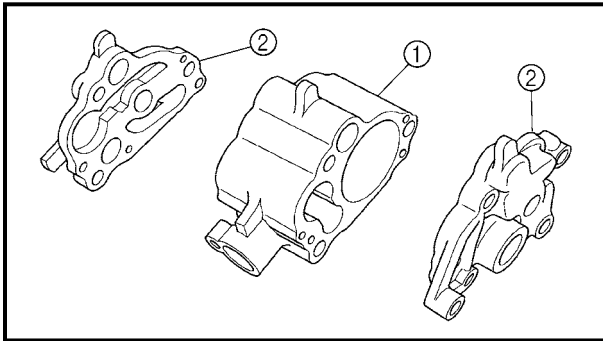

EAS00363

**CHECKING THE OIL PUMP**

1. Check:

- oil pump housing ①
- oil pump housing covers ②

Cracks/damage/wear → Replace the defective part(s).

2. Measure:

- inner rotor-to-outer rotor tip clearance ③
- outer rotor-to-oil pump housing clearance ④

Out of specification → Replace the oil pump.

- ① Inner rotor
- ② Outer rotor
- ③ Oil pump housing



**Inner rotor-to-outer rotor tip clearance**

0 ~ 0.12 mm (0 ~ 0.005 in)

**Outer rotor-to-oil pump housing clearance (feed pump)**

0.03 ~ 0.08 mm (0.001 ~ 0.003 in)

**Outer rotor-to-oil pump housing clearance (scavenging pump)**

0.06 ~ 0.11 mm (0.001 ~ 0.004 in)

3. Check:

- oil pump operation

Rough movement → Repeat steps (1) and (2) or replace the defective part(s).

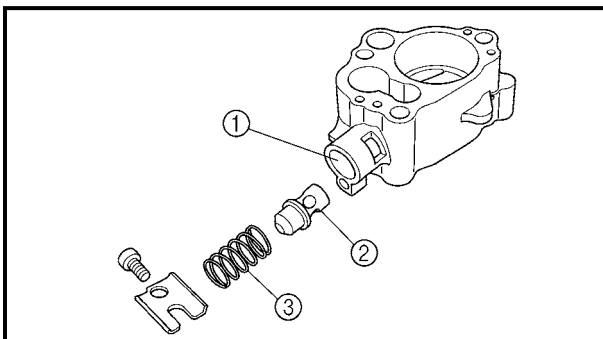
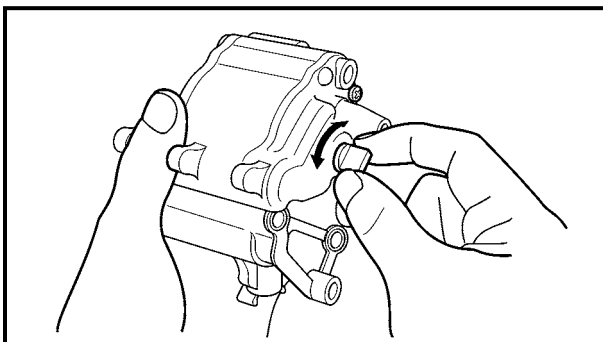

EAS00365

**CHECKING THE RELIEF VALVE**

1. Check:

- relief valve body ①
- relief valve ②
- spring ③

Damage/wear → Replace the defective part(s).

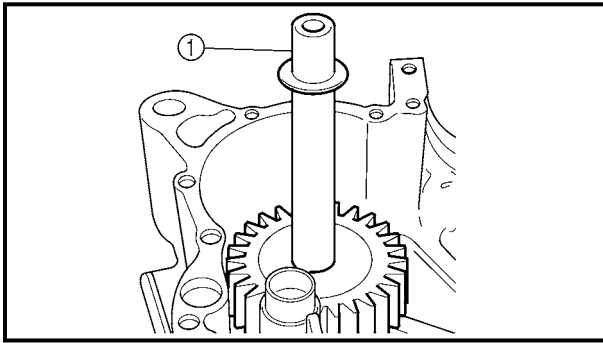
**INSTALLING THE CRANKSHAFT**

1. Install:

- generator shaft ①

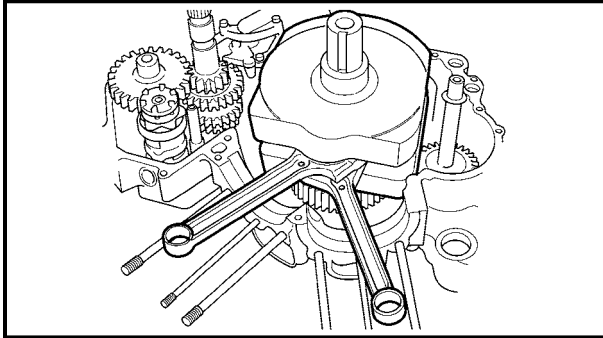

2. Install:

- crankshaft

**NOTE:**

- Make sure that the generator shaft drive gear teeth and generator shaft driven gear teeth mesh correctly.
- Align the right connecting rod with the front cylinder sleeve hole.

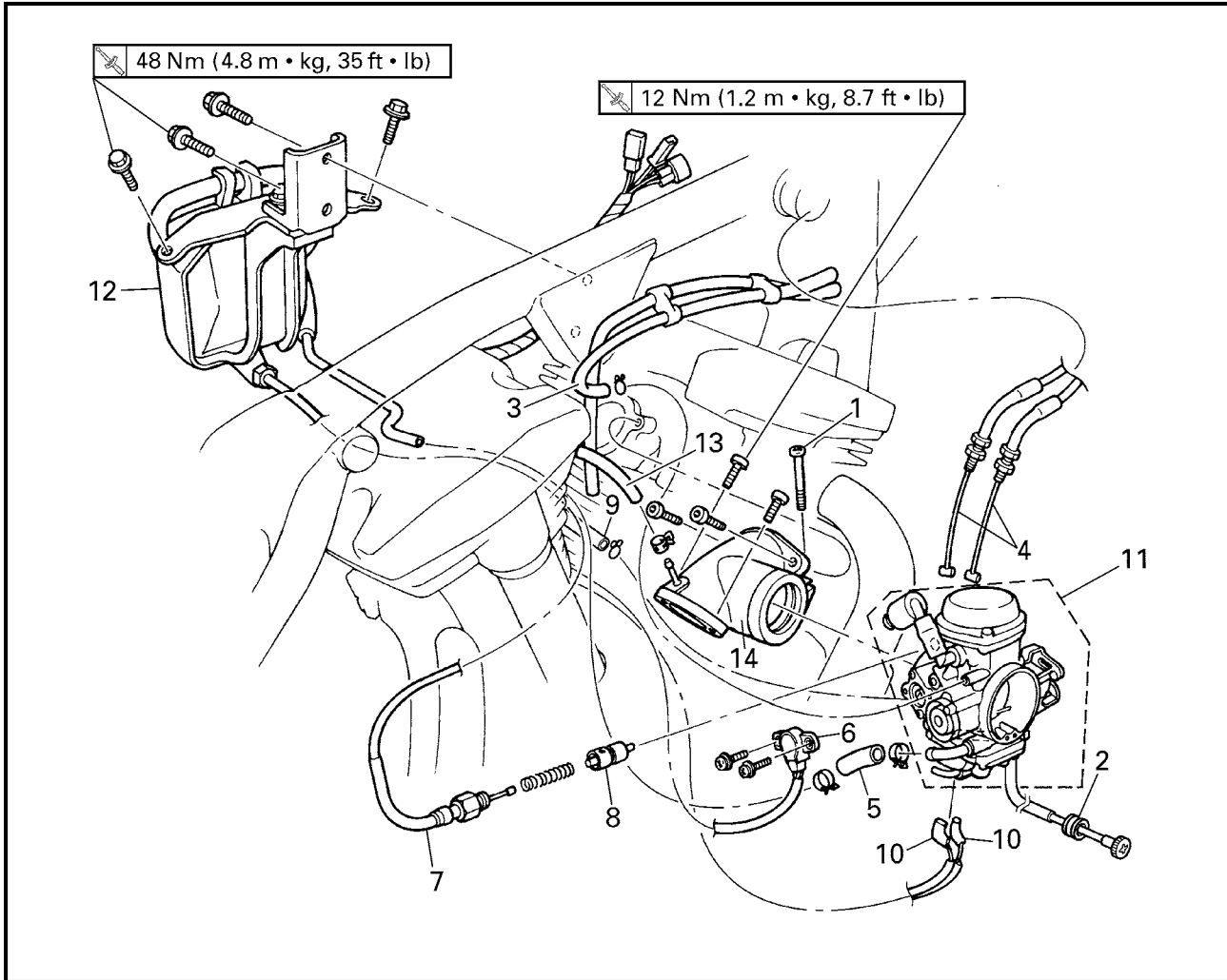

Order	Job/Part	Q'ty	Remarks
9	Charcoal canister hose (carburetor to charcoal canister)	1	Disconnect.
10	Carburetor heater connector	2	Disconnect.
11	Carburetor	1	
12	Fuel pump bracket assembly (with fuel pump)	1	
13	Vacuum hose	1	Disconnect.
14	Carburetor joint	1	
			For installation, reverse the removal procedure.



13. Install:
- throttle stop screw
  - drain hose

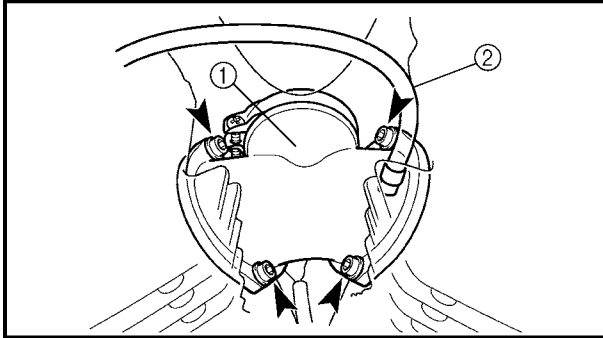

**INSTALLING THE CARBURETOR JOINT**

1. Install:
- carburetor joint ①

**12 Nm (1.2 m · kg, 8.7 ft · lb)**

2. Connect:
- vacuum hose ②

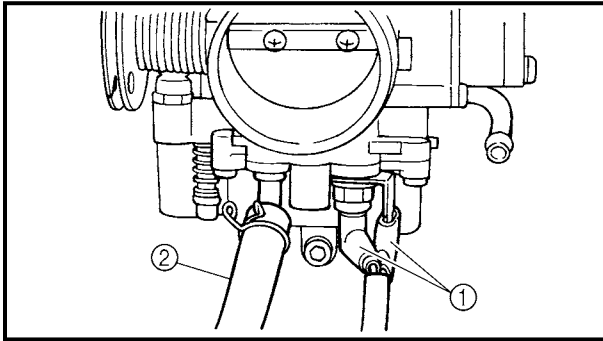

EAS00492

**INSTALLING THE CARBURETOR**

1. Connect:
- carburetor heater connectors ①
  - charcoal canister hose (carburetor to charcoal canister) ②

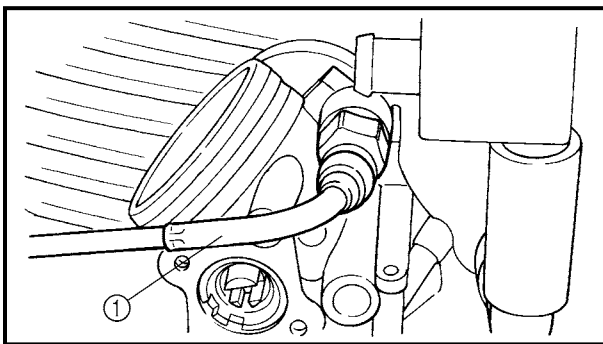

2. Install:
- starter plunger
3. Connect:
- starter cable ①

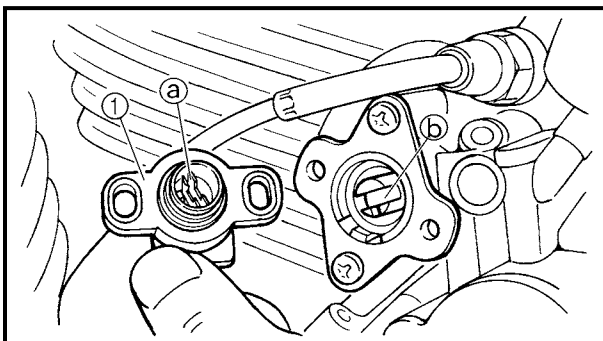

4. Install:
- throttle position sensor

**NOTE:** \_\_\_\_\_

- Align the slot ① of the throttle position sensor with the projection ② of the throttle lever shaft.
- For the correct installation, refer to "CHECKING AND ADJUSTING THE THROTTLE POSITION SENSOR".



EAS00509

AIR INDUCTION SYSTEM DIAGRAMS

- ① Reed valve
- ② Air cut valve
- ③ Air cleaner
- ④ Carburetor joint
- Ⓐ To the carburetor joint
- Ⓑ To the front cylinder head
- Ⓒ To the rear cylinder head
- Ⓓ To the air cut valve

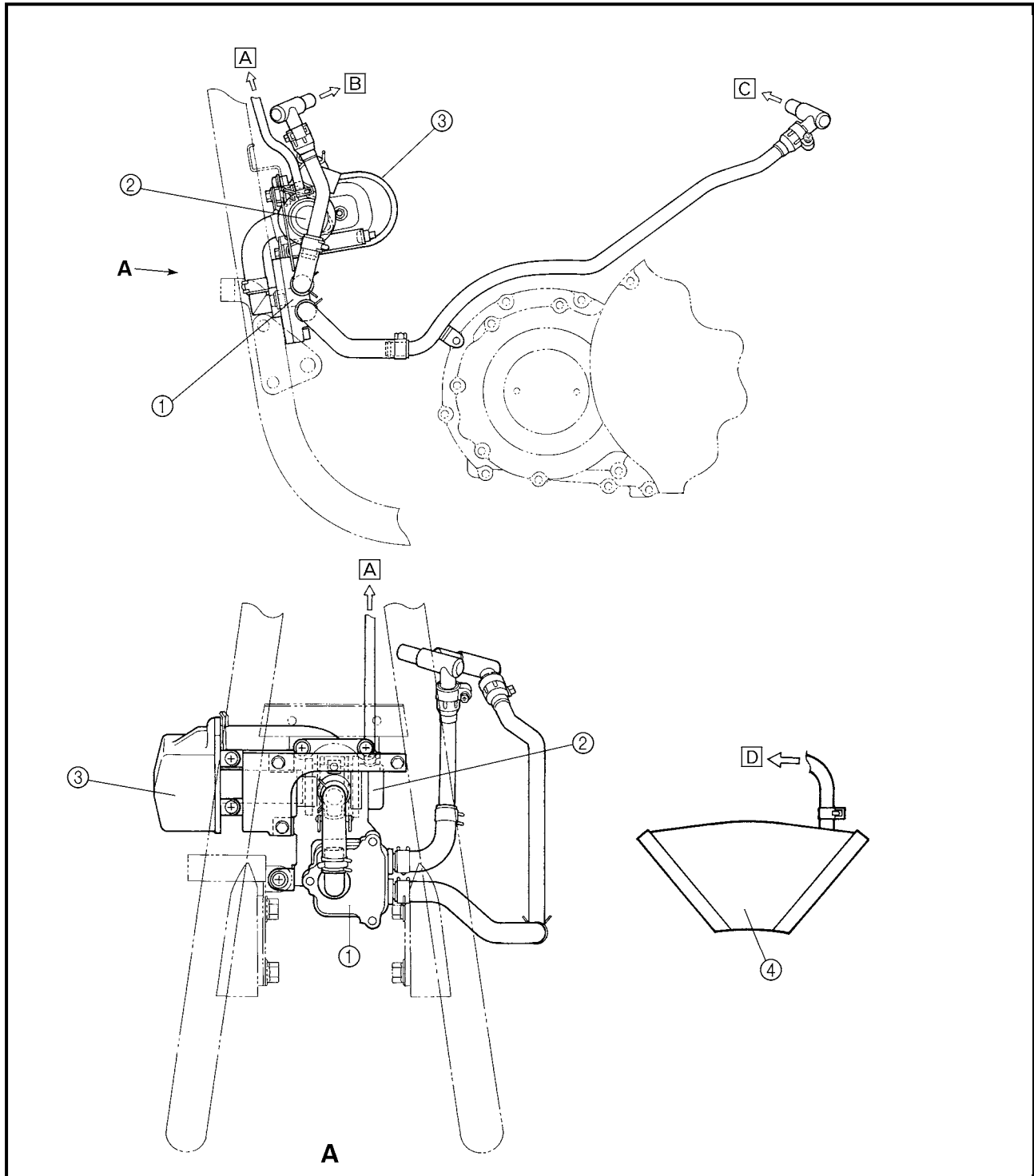

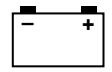

ESA00729

# ELECTRICAL SYSTEM

## ELECTRICAL COMPONENTS

- |                            |                    |                           |
|----------------------------|--------------------|---------------------------|
| ① Wire harness             | ⑪ Battery          | ⑳ Stator coil assembly    |
| ② Main switch              | ⑫ Starter relay    | ㉑ Rear brake light switch |
| ③ Front brake light switch | ⑬ Main fuse        | ㉒ Rectifier/regulator     |
| ④ Ignition coils           | ⑭ Thermo switch    |                           |
| ⑤ Throttle position sensor | ⑮ Fuse box         |                           |
| ⑥ Clutch switch            | ⑯ Speed sensor     |                           |
| ⑦ Decompression solenoid   | ⑰ Horns            |                           |
| ⑧ Relay unit               | ⑱ Neutral switch   |                           |
| ⑨ Turn signal relay        | ㉓ Sidestand switch |                           |
| ⑩ Ignitor unit             | ㉔ Pickup coil      |                           |

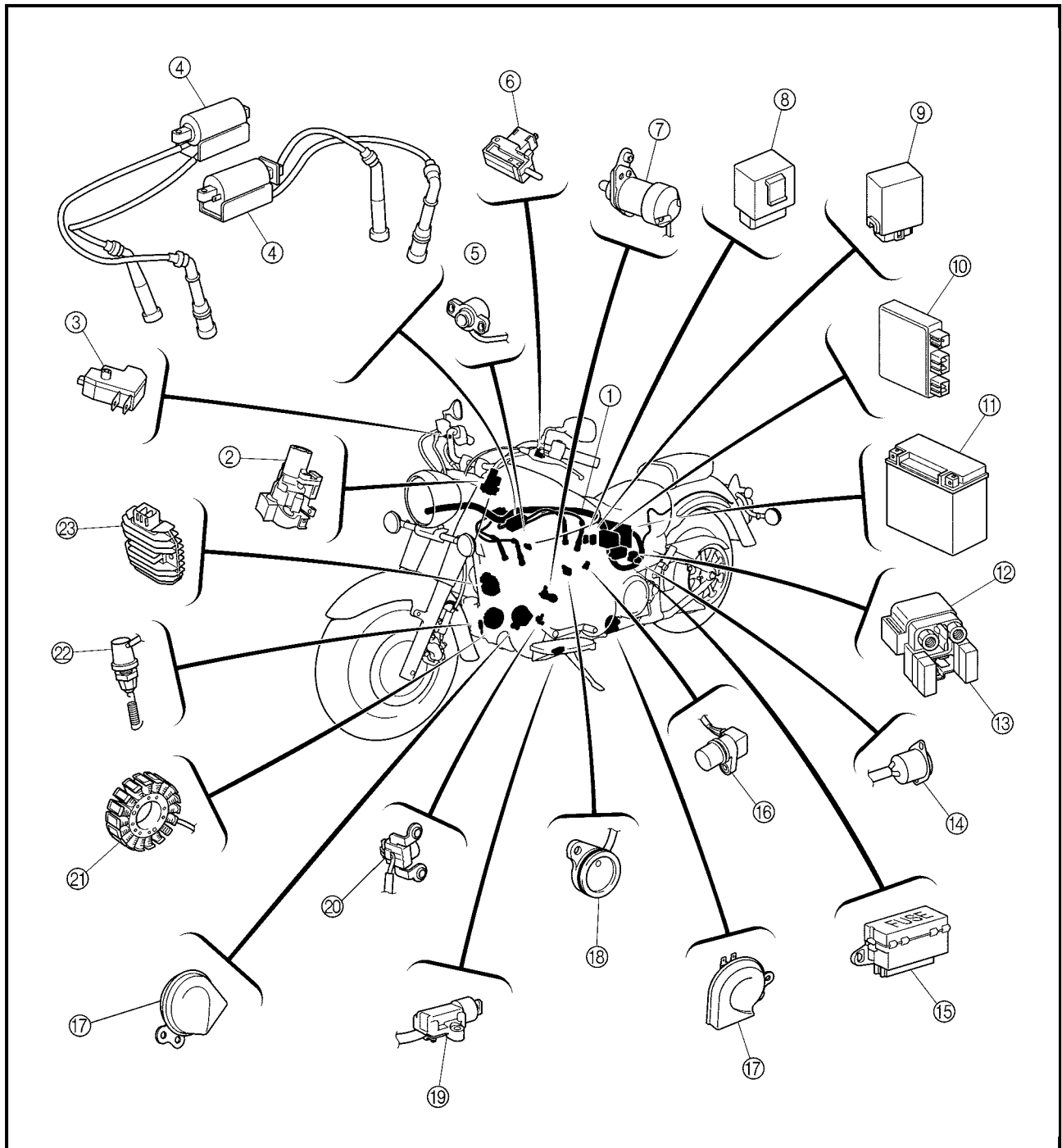

7

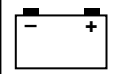

**CHECKING THE CONDITION OF THE BULB SOCKETS**

The following procedure applies to all of the bulb sockets.

1. Check:
  - bulb socket (for continuity)  
(with the pocket tester)
  - No continuity → Replace.



**NOTE:** \_\_\_\_\_

Check each bulb socket for continuity in the same manner as described in the bulb section; however, note the following.



- a. Install a good bulb into the bulb socket.
- b. Connect the pocket tester probes to the respective leads of the bulb socket.
- c. Check the bulb socket for continuity. If any of the readings indicate no continuity, replace the bulb socket.



**CHECKING THE LEDs**

The following procedure applies to all of the LEDs.

1. Check:
  - LED (for proper operation)



- a. Disconnect the meter assembly coupler (meter assembly side).
- b. Connect two jumper leads ① from the battery terminals to the respective coupler terminals as shown.

**⚠ WARNING** \_\_\_\_\_

- A wire that is used as a jumper lead must have at least the same capacity of the battery lead, otherwise the jumper lead may burn.
- This check is likely to produce sparks, therefore make sure that no flammable gas or fluid is in the vicinity.

- c. When the jumper leads are connected to the terminals the respective LED should illuminate.  
Does not light → Replace the meter assembly.

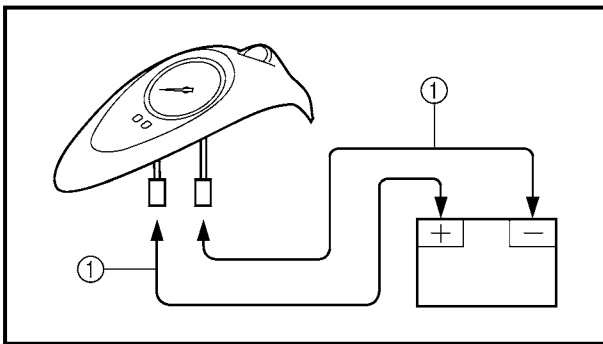

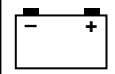

EB803404

### 6. Starter relay

- Disconnect the starter relay from the coupler.
- Connect the pocket tester ( $\Omega \times 1$ ) and battery (12 V) to the starter relay terminals as shown.

**Battery positive terminal** → red/white ①  
**Battery negative terminal** → blue ②

**Tester positive probe** → red ③  
**Tester negative probe** → black ④

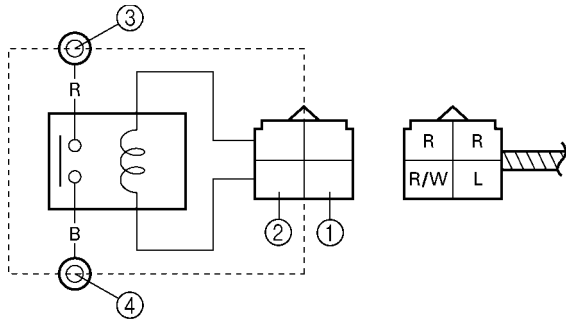

- Does the starter relay have continuity between red and black?

↓ YES

↓ NO

Replace the starter relay.

EB802411

### 7. Main switch

- Check the main switch for continuity. Refer to "CHECKING THE SWITCHES".
- Is the main switch OK?

↓ YES

↓ NO

Replace the main switch.

EB802412

### 8. Engine stop switch

- Check the engine stop switch for continuity. Refer to "CHECKING THE SWITCHES".
- Is the engine stop switch OK?

↓ YES

↓ NO

Replace the right handlebar switch.

EB802413

### 9. Neutral switch

- Check the neutral switch for continuity. Refer to "CHECKING THE SWITCHES".
- Is the neutral switch OK?

↓ YES

↓ NO

Replace the neutral switch.

EB802414

### 10. Sidestand switch

- Check the sidestand switch for continuity. Refer to "CHECKING THE SWITCHES".
- Is the sidestand switch OK?

↓ YES

↓ NO

Replace the sidestand switch.

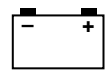

EB805000

# LIGHTING SYSTEM

## CIRCUIT DIAGRAM

- ③ Main switch
- ④ Battery
- ⑤ Main fuse
- ⑭ High beam indicator light
- ⑮ Meter light
- ⑯ Dimmer switch
- ⑰ Front turn signal/position light
- ⑱ Headlight
- ⑲ Tail/brake light
- ⑳ Headlight fuse

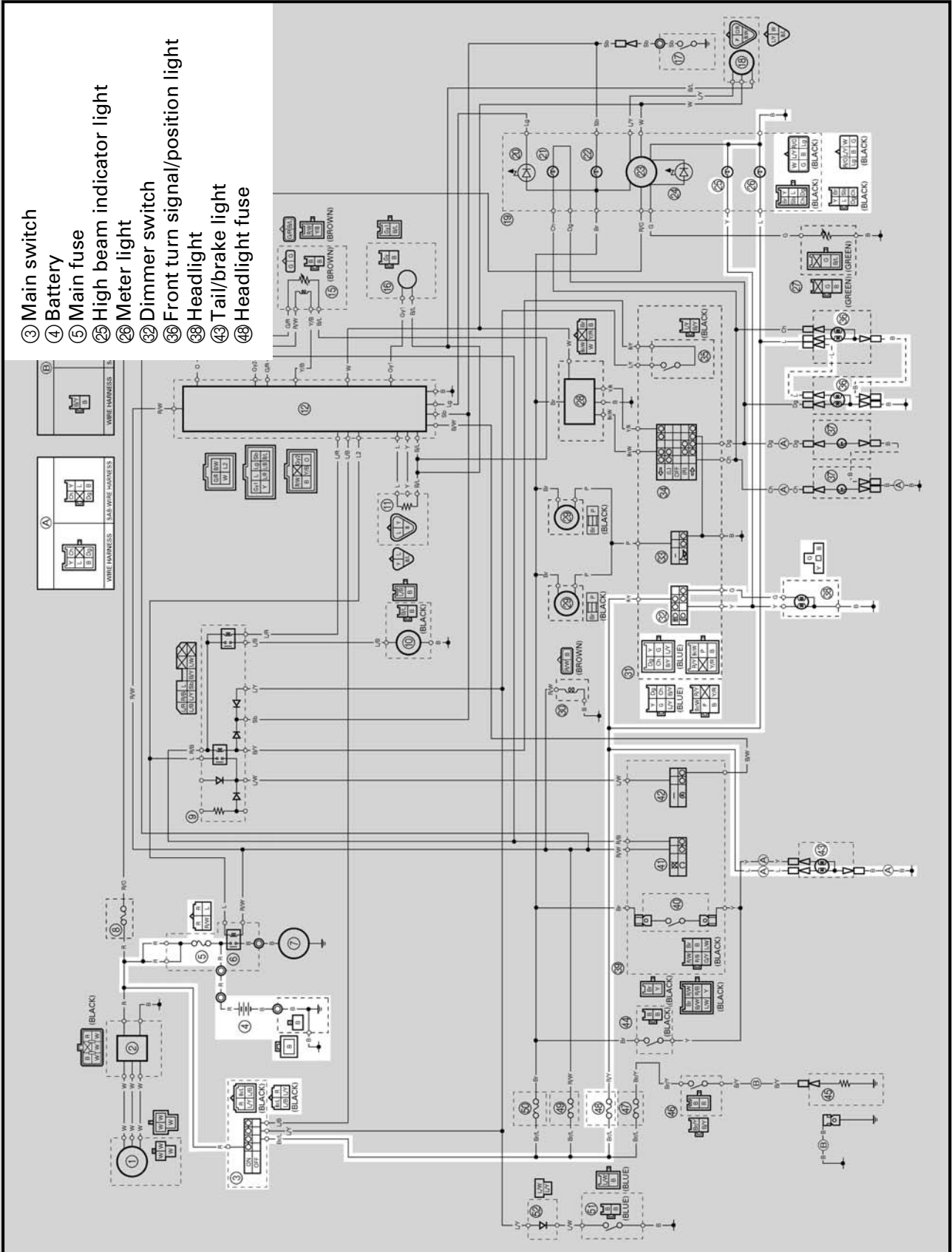

7

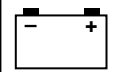

3. Turn signal switch

- Check the turn signal switch for continuity. Refer to "CHECKING THE SWITCHES".
- Is the turn signal switch OK?



Replace the left handlebar switch.

4. Voltage

- Connect the pocket tester (DC 20 V) to the turn signal relay coupler as shown.

**Tester positive probe → brown ①**  
**Tester negative probe → ground**

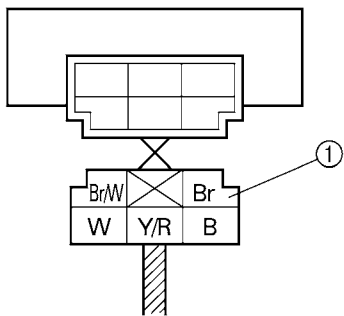

- Set the main switch to "ON".
- Measure the voltage (12 V) of brown ① at the turn signal relay coupler.
- Is the voltage within specification?



The wiring circuit from the main switch to the turn signal relay coupler is faulty and must be repaired.

5. Voltage

- Connect the pocket tester (DC 20 V) to the turn signal relay coupler as shown.

**Tester positive probe → brown/white ①**  
**Tester negative probe → ground**

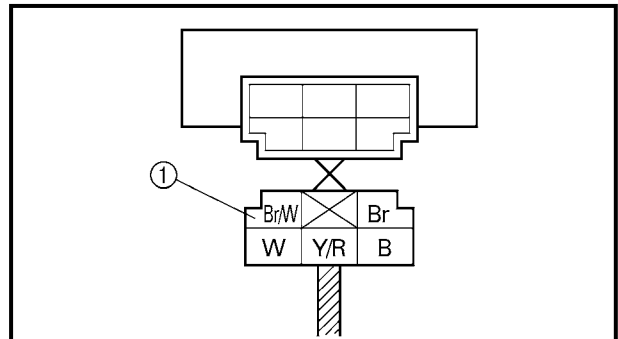

- Set the main switch to "ON".
- Set the turn signal switch to "←" or "→".
- Measure the voltage (12 V) of brown/white at the turn signal relay coupler.
- Is the voltage within specification?



The turn signal relay is faulty and must be replaced.

6. Voltage

- Connect the pocket tester (DC 20 V) to the turn signal light connectors (wire harness side) or the meter assembly coupler as shown.

- A** Turn signal light
- B** Turn signal indicator light

**Left turn signal light**  
**Tester positive probe → chocolate ①**  
**Tester negative probe → ground**  
**Right turn signal light**  
**Tester positive probe → dark green ②**  
**Tester negative probe → ground**

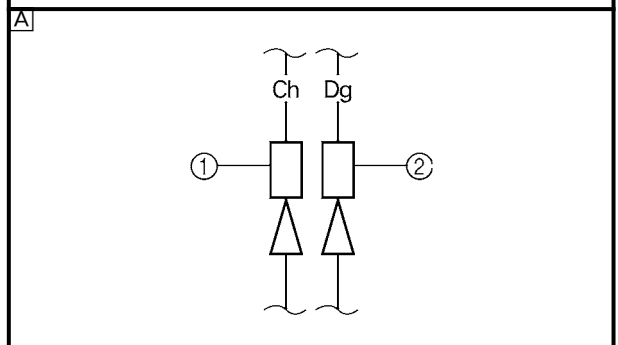

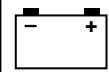

EAS00821

### TROUBLESHOOTING

**The carburetor heating system fails to operate.**

Check:

1. Main and carburetor heater fuses
2. Battery
3. Main switch
4. Thermo switch
5. Carburetor heater
6. Wiring  
(of the entire carburetor heating system)

**NOTE:**

- Before troubleshooting, remove the following part(s).
  - 1) rider seat
  - 2) fuel tank
  - 3) carburetor
  - 4) left side cover
- Troubleshoot with the following special tool(s).



**Pocket tester  
YU-03112**

EAS00738

#### 1. Main and carburetor heater fuses

- Check the main and carburetor heater fuses for continuity. Refer to "CHECKING THE FUSES" in chapter 3.
- Are the main and carburetor heater fuses OK?



Replace the fuse(s).

EAS00739

#### 2. Battery

- Check the condition of the battery. Refer to "CHECKING AND CHARGING THE BATTERY" in chapter 3.



**Minimum open circuit voltage  
12.8 V or more at 20 °C (68 °F)**

- Is the battery OK?



- Clean the battery terminals.
- Recharge or replace the battery.

EAS00749

#### 3. Main switch

- Check the main switch for continuity. Refer to "CHECKING THE SWITCHES".
- Is the main switch OK?



Replace the main switch.

EAS00823

#### 4. Thermo switch

- Remove the thermo switch from the plastic bracket.
- Connect the pocket tester to the thermo switch coupler as shown.

**Tester positive lead → black ①**  
**Tester negative lead → black ②**

- Immerse the thermo switch in a container filled with water ③.
- Place a thermometer ④ in the water.
- Slowly heat the water, then let it cool to the specified temperature as indicated in the table.
- Check the thermo switch for continuity at the temperatures indicated in the table.

CLICK HERE TO **DOWNLOAD** THE COMPLETE MANUAL

- Thank you very much for reading the preview of the manual.
- You can download the complete manual from: [www.heydownloads.com](http://www.heydownloads.com) by clicking the link below



- Please note: If there is no response to CLICKING the link, please download this PDF first and then click on it.

CLICK HERE TO **DOWNLOAD** THE COMPLETE MANUAL