

YAMAHA

Outboards

F15W

SERVICE MANUAL



LIT-18616-01-78

CLICK HERE TO **DOWNLOAD** THE COMPLETE MANUAL

- Thank you very much for reading the preview of the manual.
- You can download the complete manual from: www.heydownloads.com by clicking the link below



- Please note: If there is no response to CLICKING the link, please download this PDF first and then click on it.

CLICK HERE TO **DOWNLOAD** THE COMPLETE MANUAL



SAFETY WHILE WORKING

The procedures given in this manual are those recommended by Yamaha to be followed by Yamaha dealers and their mechanics.

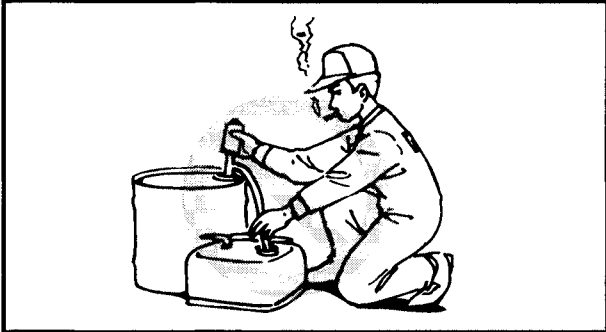

FIRE PREVENTION

Gasoline (petrol) is highly flammable. Petroleum vapor is explosive if ignited. Do not smoke while handling gasoline and keep it away from heat, sparks and open flames.

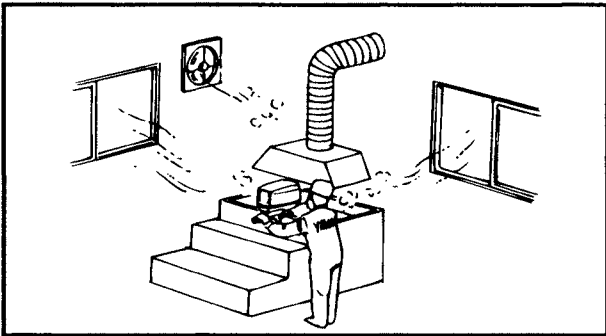

VENTILATION

Petroleum vapor is heavier than air and is deadly if inhaled in large quantities. Engine exhaust gases are harmful to breathe. When test-running an engine indoors, maintain good ventilation.

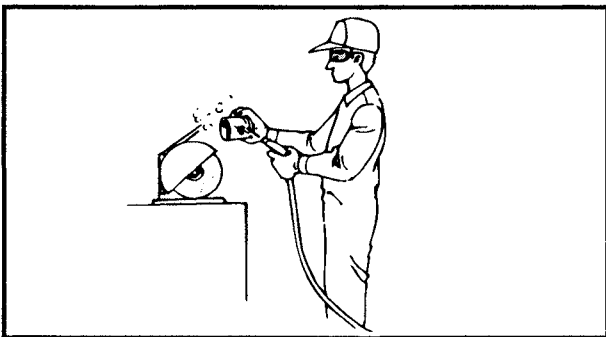

SELF-PROTECTION

Protect your eyes with suitable safety glasses or safety goggles, when grinding or when doing any operation which may cause particles to fly off. Protect hands and feet by wearing safety gloves or protective shoes if appropriate to the work you are doing.



OILS, GREASES AND SEALING FLUIDS

Use only genuine Yamaha oils, greases and sealing fluids or those recommended by Yamaha.



GENERAL SPECIFICATIONS

Item	Unit	Model			
		World wide	F15AMH	F15AEH	F15AE
		USA/CANADA	F15MHW	F15EHW	—
DIMENSION					
Overall length	mm (in)	1,003 (39.5)	1,003 (39.5)	643 (25.3)	
Overall width	mm (in)	427 (16.8)	427 (16.8)	369 (14.5)	
Overall height					
(S)	mm (in)	1,080 (42.5)			
(L)	mm (in)	1,207 (47.5)			
WEIGHT					
(With aluminum proper)					
(S)	kg (lb)	45.0 (99.2)	48.0 (105.8)	47.0 (103.6)	
(L)	kg (lb)	47.0 (103.6)	50.0 (110.2)	49.0 (108.0)	
PERFORMANCE					
Maximum output (ISO)	kW (hp) @ r/min	11.0 (15)/@ 5,000			
Full throttle operating	r/min	4,500~5,500			
Maximum fuel consumption	L (U.S, gal, Imp gal) @ 5,500 r/min	5.3 (1.39, 1.16)			
POWER UNIT					
Type		4 stroke, OHC, in-line			
Number of cylinders		2			
Displacement	cm ³ (cu. in)	323 (19.7)			
Bore x stroke	mm (in)	59.0x59.0 (2.32x2.32)			
Compression ratio		9.19			
Compression pressure	kPa (kg/cm ² , psi)	1,196 (12.2, 173.5)			
Number of carburetors		1			
Control system		Tiller control		Remote control	
Starting system		Recoil starter	Electric motor		
Ignition control system		C.D.I.			
Lighting coil		Single phase			
Lighting coil output	V-W / V-A	AC12-80	DC12-6/12-10 with rectifier		
Starting enrichment		Choke valve			
Spark plug		DPR6EA-9			
Exhaust system		Propeller hub			
Lubrication system		Wet sump			
Ignition timing	Degree°(BTDC)	5 ~30			
FUEL AND OIL					
Fuel type		Unleaded regular gasoline			
Fuel rating	PON*	86			
	(*PON: Pump Octane Number)				
	RON*	91			
	(*RON: Research Octane Number)				



Part to be tightened	Part name	Thread size	Q'ty	Tightening torque		
				Nm	m•kg	ft•lb
Oil drain plug	Bolt	M14	1	27	2.7	19.5
Exhaust manifold	Bolt	M6	2	11	1.1	8.0
Propeller	Nut	M10	1	17	1.7	12.3
Water inlet cover	Screw	M5	1	5	0.5	3.6
ELECTRICAL						
Oil pressure switch	Bolt	—	1	8	0.8	5.8
Starting motor terminal (A=7/16")	Nut	1/4"	1	9	0.9	6.5
Starting motor through bolt (A=3/8")	Bolt	3/16"	2	8	0.8	5.8

Nut (A)	Bolt (B)	General torque specifications		
		Nm	m•kg	ft•lb
8 mm	M5	5.0	0.5	3.6
10 mm	M6	8.0	0.8	5.8
12 mm	M8	18	1.8	13
14 mm	M10	36	3.6	25
17 mm	M12	43	4.3	31

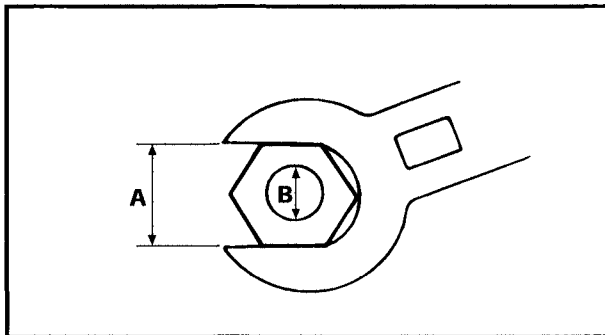

GENERAL TORQUE

This chart specifies the torques for tightening standard fasteners with standard clean dry ISO threads at room temperature. Torque specifications for special components or assemblies are given in applicable sections of this manual. To avoid causing warpage, tighten multifastener assemblies in crisscross fashion, in progressive stages until the specified torque is reached.





3. Measure:
 - Idle speed
 - Out of specification → Adjust.

	Idle speed: 950 ± 50r/min.
Measurement steps: <ul style="list-style-type: none"> • Start the engine and allow it to warm up for a few minutes. • Attach the tachometer to the spark plug lead of cylinder #1. 	
	Tachometer: 90890-06760

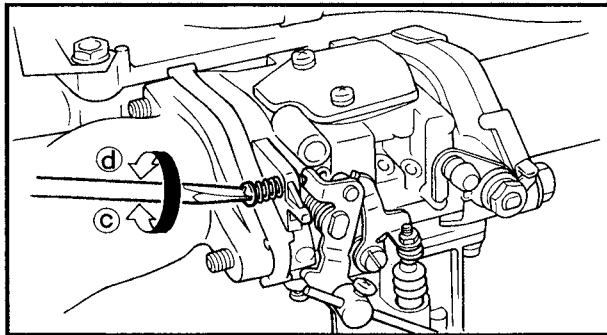
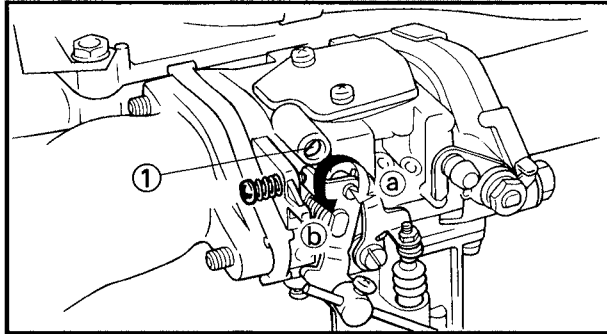

4. Adjust:
 - Idle speed

Adjustment steps: <ul style="list-style-type: none"> • Turn the pilot screw ① in direction ③ or ④ until the idle speed is highest position. • Turn the throttle stop screw in direction ⑤ or ⑥ until the specified idle speed is obtained. 	
Turning in ⑤ → Idle speed is increases. Turning out ⑥ → Idle speed is decreases.	

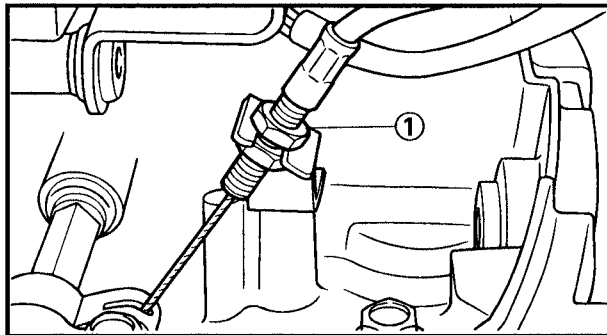

Start-in-gear protection adjustment (F15AMH)

1. Check:
 - Start-in-gear protection operation
 - Incorrect → Adjust.
2. Adjust:
 - Start-in-gear protection wire

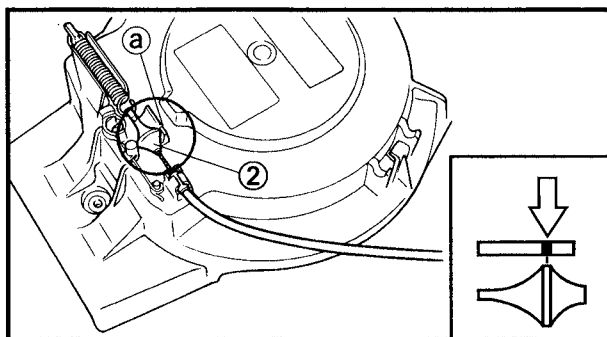

Adjustment steps: <ul style="list-style-type: none"> • Set the shift lever in neutral. • Loosen the locknut ①. • Adjust the start-in-gear protection wire adjuster so that the marking a of wire end ② aligns with the marking ③ of the starter case. • Tighten the locknut. 	
---	--

Compression pressure (With oil applied into cylinder)	
Reading	Diagnosis
Higher than without oil	Worn or damaged pistons
Same as without oil	Possible defective ring(s), valves, cylinder head gasket or piston → Repair.

7. Measure:

- Compression pressure

If it exceeds the maximum pressure allowed → Inspect the cylinder head, valve surfaces and piston crown for carbon deposits.

If it is below the minimum pressure → Squirt a few drops of oil into the affected cylinder and measure again.

Follow the table below.

	Compression pressure:
	Standard: 1,196 kPa (12.2 Kg/cm ² , 173.5 psi)

Measurement steps:

- Crank the engine with the throttle wide-open until the reading on the compression gauge stabilizes.

⚠WARNING

Before cranking the engine, ground all spark plug leads to prevent sparking.

8. Install:

- Spark plug



**CARBURETOR
EXPLODED DIAGRAM**

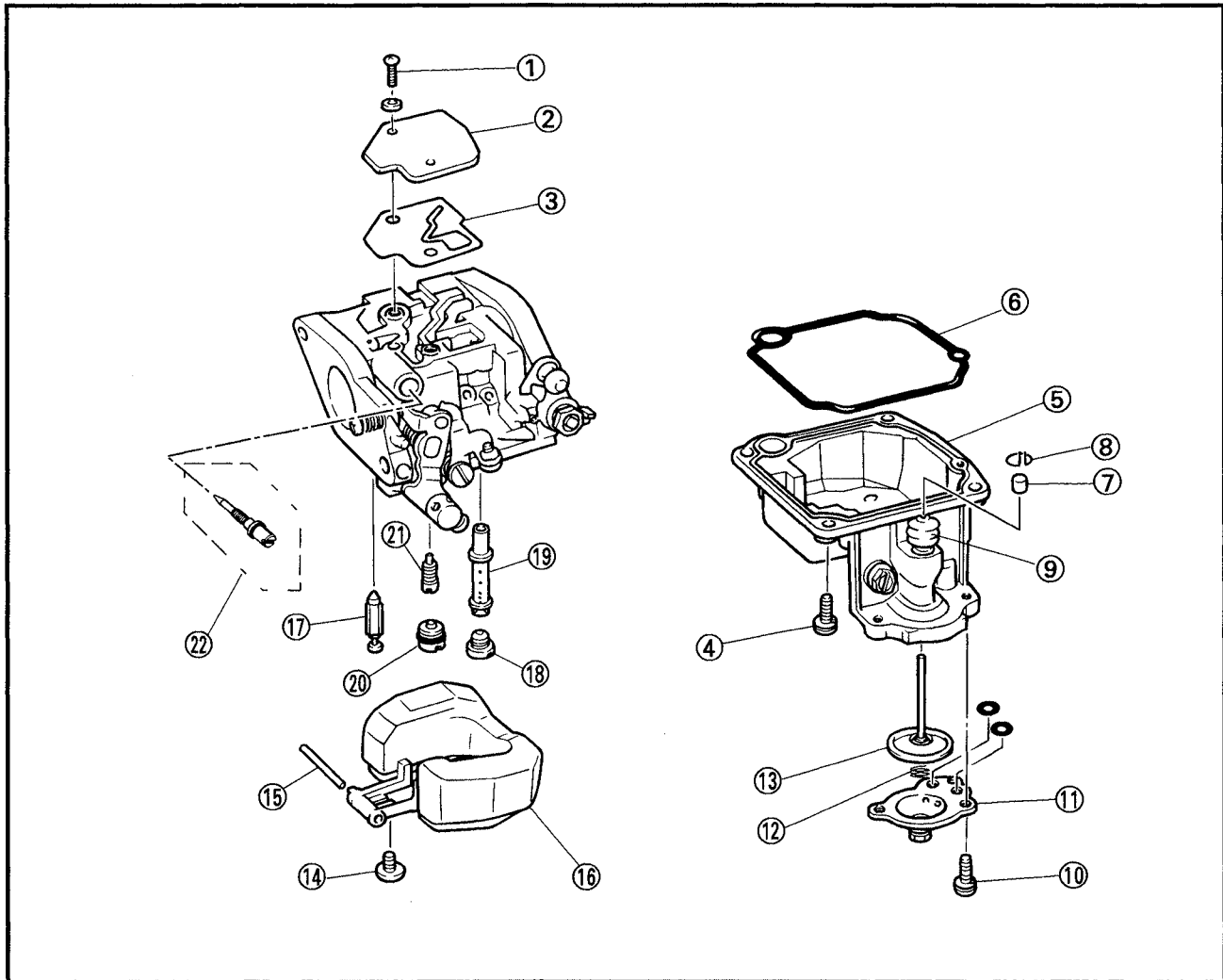

REMOVAL AND INSTALLATION CHART

Step	Procedure/Part name	Q'ty	Service points
	CARBURETOR DISASSEMBLY		Follow the left "Step" for disassembly.
	Carburetor assembly		
①	Screw	2	
②	Carburetor top cover	1	
③	Gasket (carburetor top cover)	1	
④	Screw (float chamber)	4	
⑤	Float chamber	1	
⑥	Packing	1	
⑦	Plunger rod cap	1	
⑧	Clip	1	
⑨	Rubber boot	1	
⑩	Screw	3	
⑪	Diaphragm cover	1	
⑫	Spring	1	

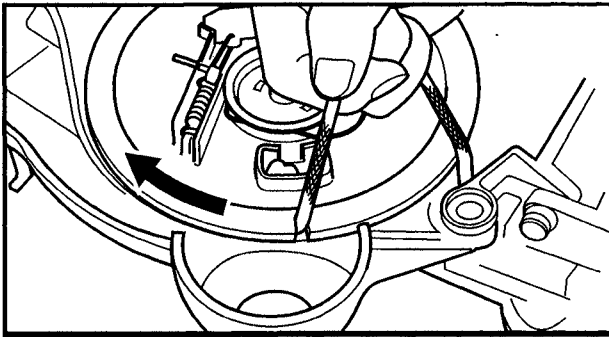

SERVICE POINTS

Sheave drum removal

1. Rotate:
 - Sheave drum
 Turn the sheave drum clockwise until the spring is free.

NOTE:

- Turn the sheave drum so that the cutaway on the outer surface of the sheave drum faces toward the starter handle.
- Pass the starter rope through the cut.

2. Remove:
 - Drive plate
 - Sheave drum

⚠WARNING

When removing the drive plate and sheave drum, be sure to turn the sheave drum upside down to prevent the spiral spring from popping up at you.

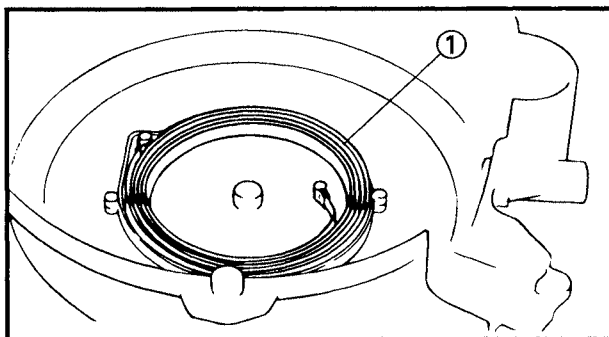

Spiral spring removal

1. Remove:
 - Spiral spring ①

⚠WARNING

Be careful so that the spiral spring does not pop out when removing it. remove it by allowing it out one turn of the winding each time.

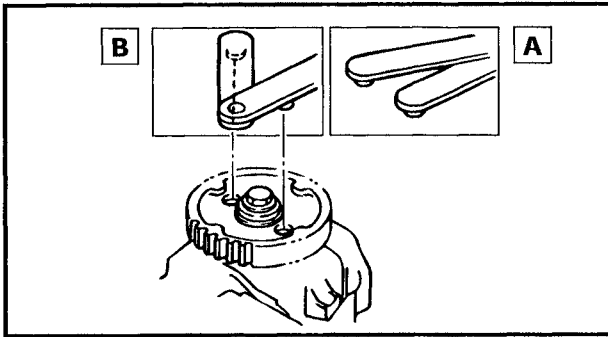
**Driven sprocket installation**

1. Install:
 - Bolt

**Flywheel holder:****YB-06139/90890-06522**

- A For USA and CANADA
- B Except for USA and CANADA

Timing belt slack inspection

1. Inspect:
 - Timing belt slackOut of specification → Replace.
Refer to the "POWER UNIT inspection" in chapter 3.

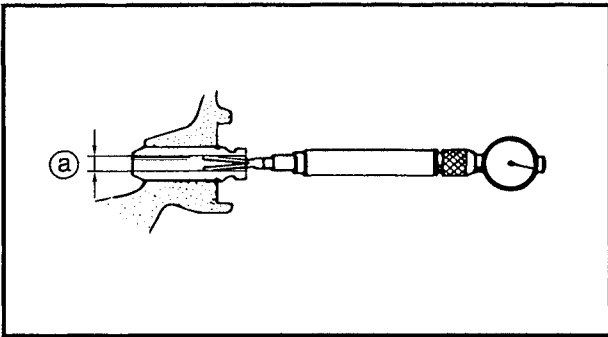

SERVICE POINTS

Valve inspection

1. Measure:
 - Valve guide inside diameter (a)
 Out of specification → Replace the valve guide.



Valve guide inside diameter:
5.500 ~5.512 mm
(0.2165 ~ 0.2170 in)

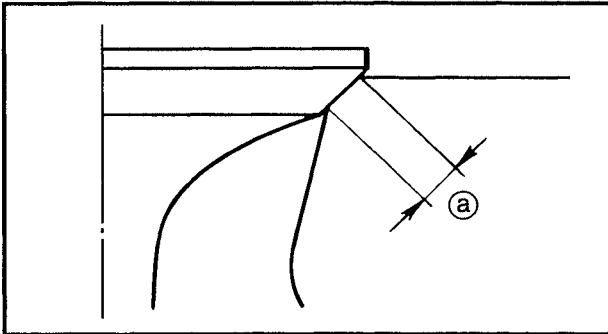

2. Measure:
 - Valve seat width (a)
 Out of specification → Reface the valve seat.



Valve seat width :
2.0 ~ 3.1 mm (0.079 ~ 0.122 in)

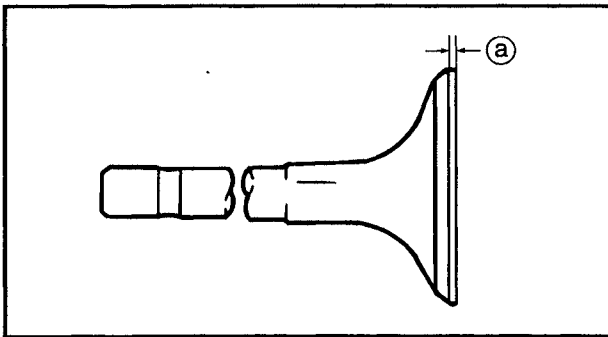

3. Measure:
 - Margin thickness (a)
 Out of specification → Replace the valve.



Margin thickness:
0.50 ~ 0.90 mm (0.020 ~0.035 in)

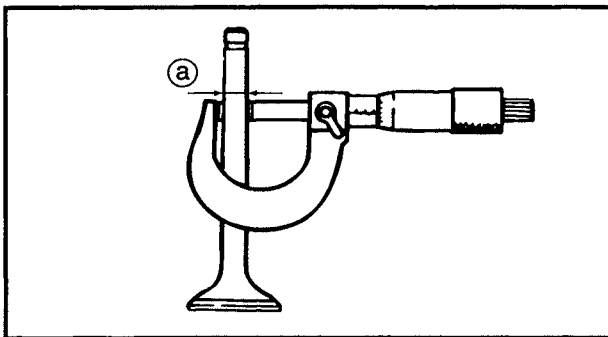

4. Measure:
 - Valve stem diameter (a)
 Out of specification → Replace the valve.



Diameter:
IN :5.475 ~5.490 mm
(0.2155 ~ 0.2161 in)
EX:5.460 ~5.475 mm
(0.2150 ~ 0.2156 in)



**CRANKCASE AND CRANKSHAFT
EXPLODED DIAGRAM**

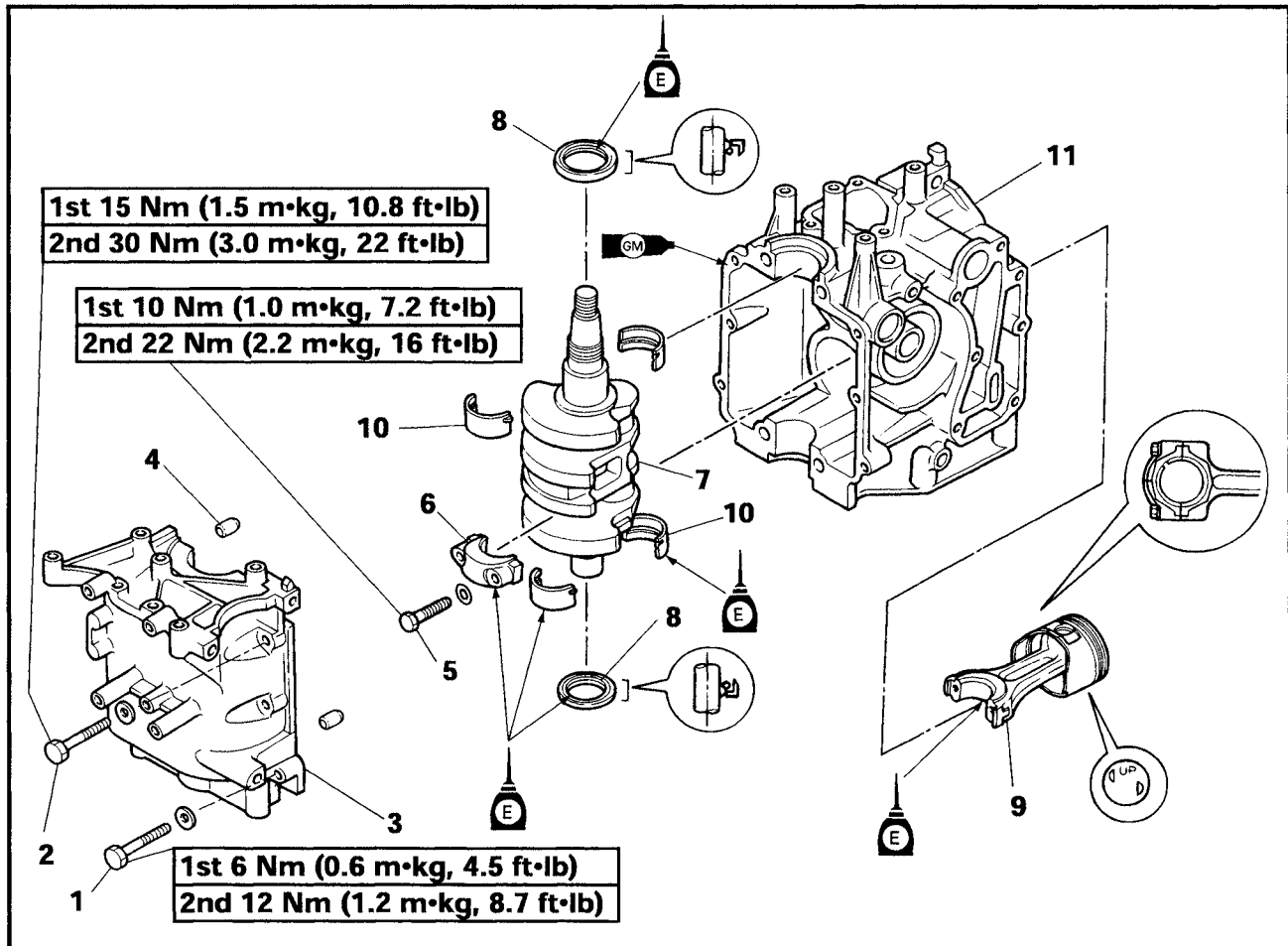

REMOVAL AND INSTALLATION CHART

Step	Procedure/Part name	Q'ty	Service points
	CRANKCASE AND CRANKSHAFT DISASSEMBLY		Follow the left "Step" for disassembly.
1	Bolt (crankcase)	6	M6 x 35 mm
2	Bolt (crankcase)	4	M8 x 55 mm
3	Crankcase	1	
4	Dowel pins	2	
5	Bolt (connecting rod cap)	4	M7 x 38 mm (Exclusive part)
6	Connecting rod cap	2	
7	Crankshaft	1	
8	Oil seal	2	
9	Connecting rod and piston ass'y	2	NOTE: _____ Install the connecting rod and piston ass'y upward "Y" mark side.
10	Main bearings	4	
11	Cylinder body	1	
			Reverse the disassembly steps for assembly.

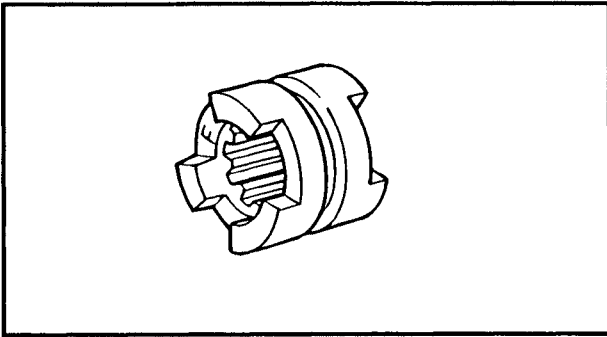
**SERVICE POINTS****Dog clutch inspection**

1. Inspect:
 - Dog clutch
Wear/Damage → Replace.

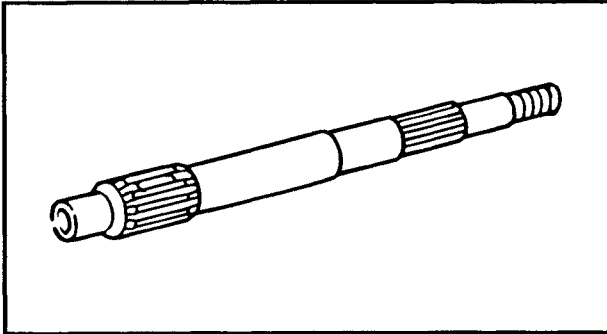
**Propeller shaft inspection**

1. Inspect:
 - Propeller shaft
Wear/Damage → Replace.

CLICK HERE TO **DOWNLOAD** THE COMPLETE MANUAL

- Thank you very much for reading the preview of the manual.
- You can download the complete manual from: www.heydownloads.com by clicking the link below



- Please note: If there is no response to CLICKING the link, please download this PDF first and then click on it.

CLICK HERE TO **DOWNLOAD** THE COMPLETE MANUAL

LOWR



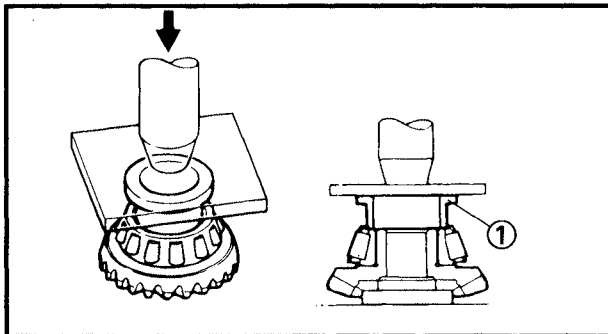
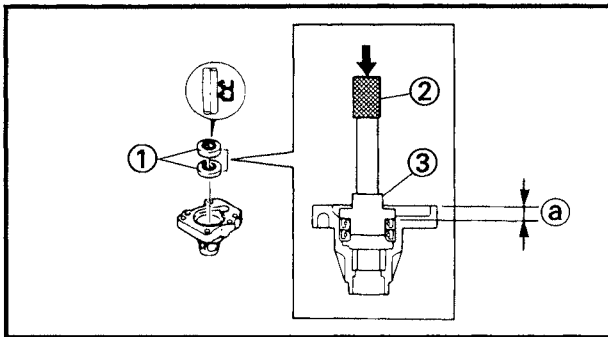
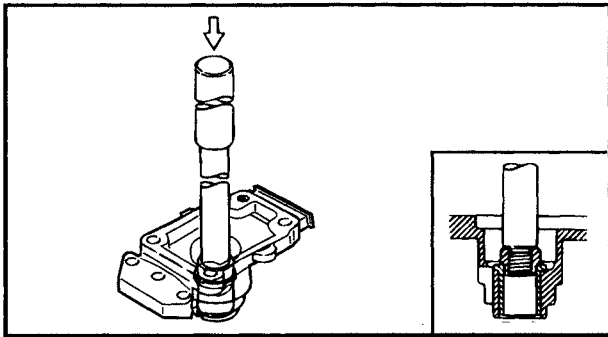
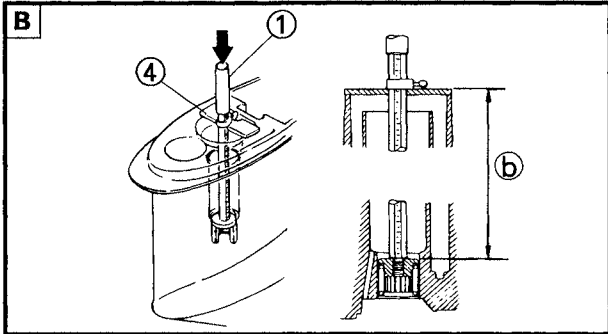
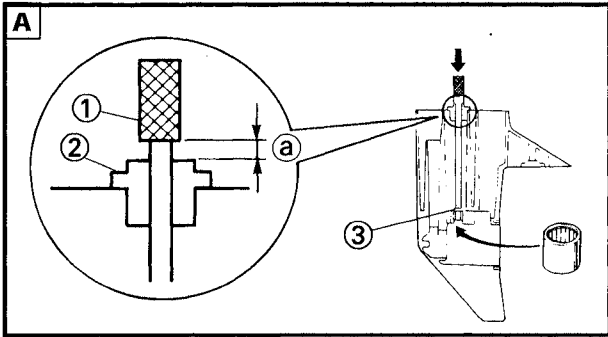

DRIVE SHAFT, FORWARD GEAR, SHIFT ROD AND OIL SEAL HOUSING

E



2. Install:
• Needle bearing

 **Needle bearing depth (a):**
17.8 mm (0.70 in)
Needle bearing depth (b):
172.7~173.2 mm (6.08~6.82 in)

 **Driver rod (1):**
YB-06229/90890-06602
Drive shaft needle bearing depth stop (2):
YB-06231
Needle bearing attachment (3):
YB-06230/90890-06617
Bearing depth plate (4):
90890-06603

- A** For USA and CANADA
B Except for USA and CANADA

NOTE: _____
Install the drive shaft needle bearing with the manufacturer's marks facing up.

Oil seal housing assembly

1. Install:
• Busing

 **Bushing attachment:**
YB-06028/90890-06649
Driver rod:
YB-06229/90890-06604

2. Install:
• Oil seal (1)

 **Depth (a):**
7.0 ~ 8.0 mm (0.28 ~0.31 in)

 **Driver rod (2):**
YB-06071/90890-06604
Bearing installer (3):
(Bearing inner race attachment)
YB-06022/90890-06613

Forward gear assembly

1. Install:
• Tapered roller bearing
(to the forward gear)

 **Bearing inner race attachment (1):**
90890-06644



SWIVEL AND STEERING BRACKET EXPLODED DIAGRAM

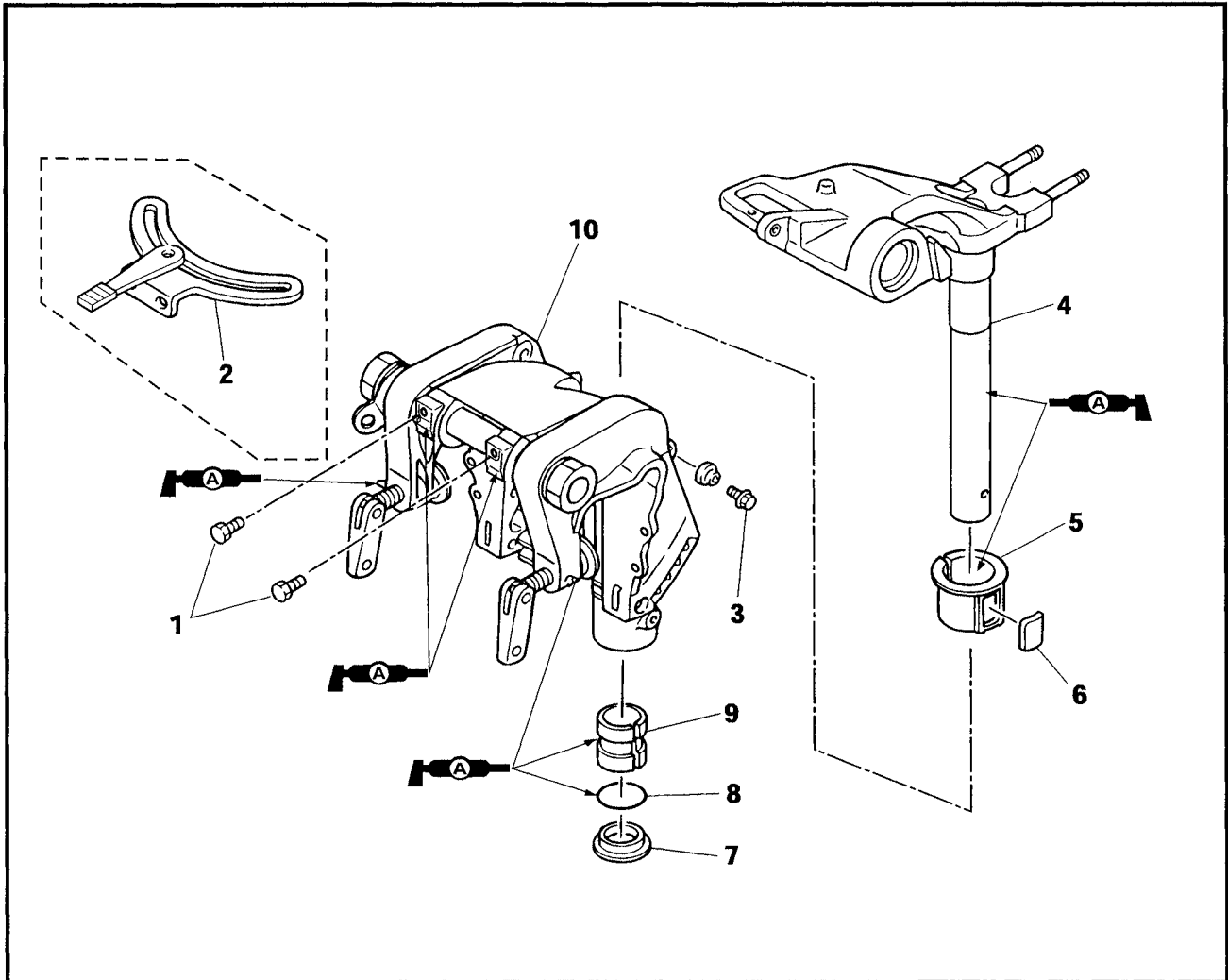

REMOVAL AND INSTALLATION CHART

Step	Procedure/Part name	Q'ty	Service points
	SWIVEL AND STEERING BRACKET REMOVAL		Follow the left "Step" for removal.
1	Bolt (AEH)	2	
2	Steering friction ass'y (AMH, AEH)	1	NOTE: _____
3	Friction bolt	1	Loosen the friction bolt.
4	Steering bracket	1	_____
5	Busing	1	
6	Key	1	
7	Bushing	1	
8	O-ring	1	
9	Bushing	1	
10	Swivel bracket ass'y	1	
			Reverse the removal steps for installation.



(Rear views)

F15 AMH

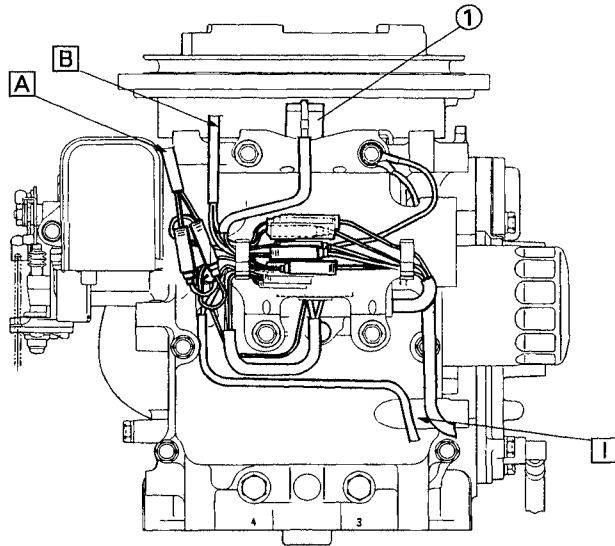

F15 AEH

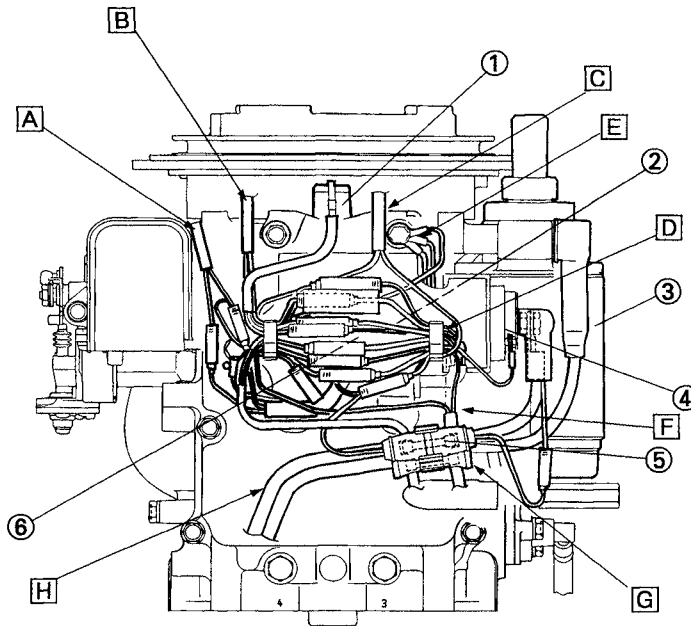

- ① Pulsar coil
- ② CDI unit
- ③ Starting motor (AEH)
- ④ Starter relay (AEH)
- ⑤ Fuse (AEH : 10A/20A)
- ⑥ Rectifier-regulator (AM, AEH)
Rectifier (AEH)

- A To lighting coil.
- B To low-oil-pressure warning indicator.
- C To starter switch. (AEH)
- D Clamp with the CDI unit lead and stop switch lead.
- E Mount with the CDI unit ground lead and the wireharness ground lead. (AEH :

- with starter relay ground lead)
- F To neutral switch.
- G Clamp the fuse holder to the battery lead. (AEH)
- H To wireharness.
- I To stop switch.



IGNITION SYSTEM PEAK VOLTAGE

⚠ WARNING

When checking the CDI unit do not touch any of the connections of the digital tester lead wires.

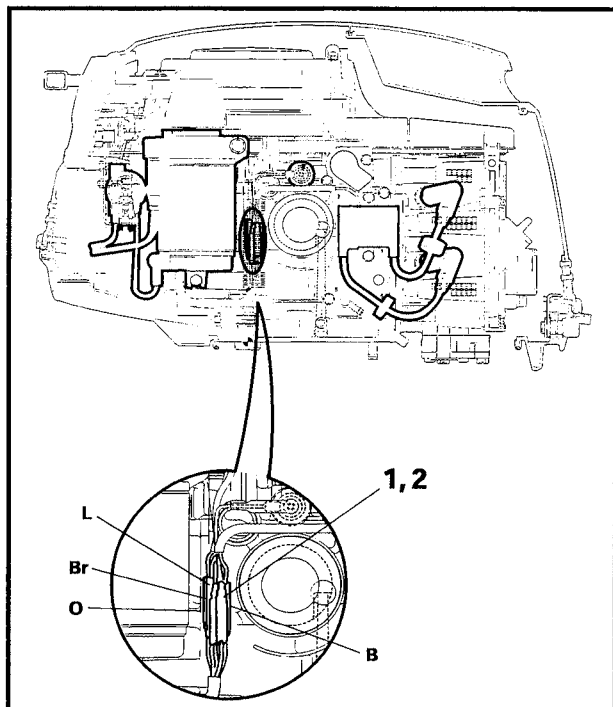

1. Measure:

- CDI unit output peak voltage
Below specification → Replace the ignition coil or check the CDI unit.

6A model

Output peak voltage O-B				
r/min	Cranking		1,500	3,500
	Opened	Closed		
V	120	115	160	160

10A model

Output peak voltage O-B				
r/min	Cranking		1,500	3,500
	Opened	Closed		
V	120	120	160	160

2. Measure:

- Charge coil output peak voltage
Below specification → Replace the charge coil.

6A model

Output peak voltage Br-L				
r/min	Cranking		1,500	3,500
	Opened	Closed		
V	130	135	180	180

10A model

Output peak voltage Br-L				
r/min	Cranking		1,500	3,500
	Opened	Closed		
V	130	135	180	180



**STARTING MOTOR (AEH, AE)
EXPLODED DIAGRAM**

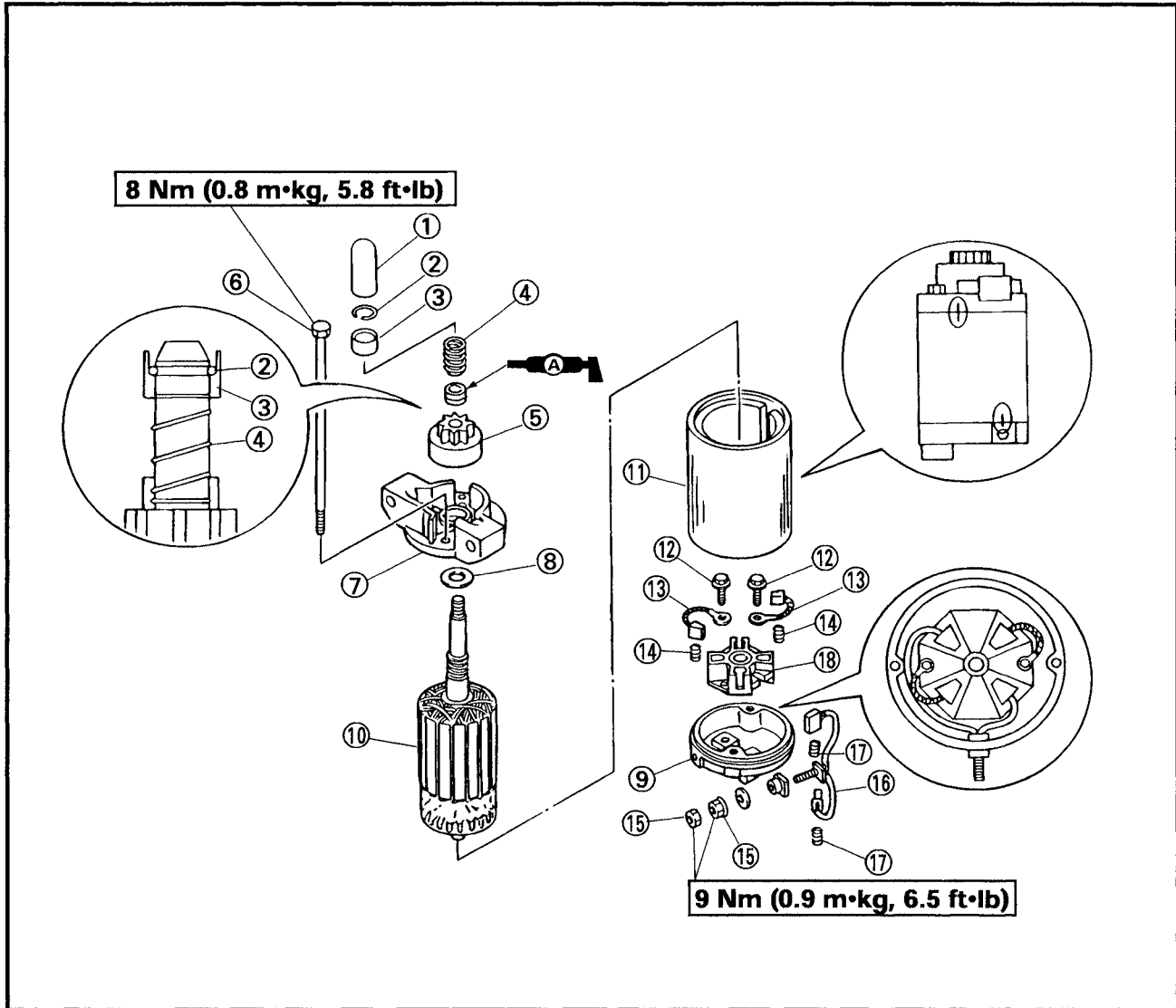

REMOVAL AND INSTALLATION CHART

Step	Procedure/Part name	Q'ty	Service points
	STARTING MOTOR DISASSEMBLY		Follow the left "Step" for disassembly.
①	Cap	1	
②	Clip	1	
③	Pinon stopper	1	
④	Spring	1	
⑤	Pinion	1	
⑥	Bolt	2	3/16" (3/8" Tool)
⑦	Front bracket	1	
⑧	Washer	1	
⑨	Rear bracket	1	
⑩	Armature	1	

TROUBLE ANALYSIS

NOTE:

The following items should be checked before the "Trouble analysis" chart is consulted.

- 1.The battery is charged and its specified gravity is within specification.
- 2.There are no incorrect wiring connections.
- 3.Wiring connections are properly secured and are not rusty.
- 4.The lanyard is attached to the engine stop switch.
- 5.The shift position is in neutral.
- 6.Fuel is reaching the carburetor.
- 7.The rigging and engine settings are correct.
- 8.The engine is free from any "Hull problem".

TROUBLE ANALYSIS CHART

Trouble mode										Check elements	
ENGINE WILL NOT START	ROUGH IDLING	ENGINE STALLS	ENGINE WILL NOT STOP	POOR PERFORMANCE	OVERHEATING	LOOSE STEERING	HARD SHIFTING	IRREGULAR WARNING INDICATION	POOR BATTERY CHARGING	Relative part	Reference Chapter
										FUEL SYSTEM	
<input type="radio"/>		<input type="radio"/>		<input type="radio"/>						Fuel hose	4
<input type="radio"/>				<input type="radio"/>						Fuel joint	4
<input type="radio"/>	<input type="radio"/>			<input type="radio"/>						Fuel filter	4
<input type="radio"/>				<input type="radio"/>						Fuel pump	4
<input type="radio"/>	<input type="radio"/>			<input type="radio"/>						Carburetor	4
	<input type="radio"/>	<input type="radio"/>		<input type="radio"/>						• Idle speed	3
	<input type="radio"/>	<input type="radio"/>		<input type="radio"/>	<input type="radio"/>					• Pilot screw*	*
<input type="radio"/>	<input type="radio"/>	<input type="radio"/>		<input type="radio"/>	<input type="radio"/>					• Pilot jet	3
		<input type="radio"/>		<input type="radio"/>						Throttle cable	3
										POWER UNIT	
<input type="radio"/>	<input type="radio"/>	<input type="radio"/>	<input type="radio"/>		<input type="radio"/>					Spark plugs	3
<input type="radio"/>	<input type="radio"/>			<input type="radio"/>						Compression	3
<input type="radio"/>										Timing belt	5
<input type="radio"/>										Valve clearance	3
<input type="radio"/>	<input type="radio"/>			<input type="radio"/>						Intake and exhaust valves	5
<input type="radio"/>	<input type="radio"/>			<input type="radio"/>						Intake and exhaust valve seat	5
<input type="radio"/>	<input type="radio"/>									Cylinder head gasket	5
<input type="radio"/>				<input type="radio"/>						Piston rings	5
<input type="radio"/>				<input type="radio"/>						Piston	5
					<input type="radio"/>					Thermostat	5
					<input type="radio"/>					Water passage	5

*Except for USA

OIL FILTER, THERMOSTAT AND EXHAUST COVER.....	31
DISASSEMBLING/ASSEMBLING THE OIL FILTER, THERMOSTAT AND EXHAUST COVER.....	31

BRACKET UNIT

STEERING HANDLE ASSEMBLY (F15AHP/F15PH)	33
REMOVING/INSTALLING THE STEERING HANDLE ASSEMBLY.....	33
DISASSEMBLING/ASSEMBLING THE STEERING HANDLE ASSEMBLY.....	34
INSTALLING THE PT SWITCH	36
BOTTOM COWLING ASSEMBLY	37
REMOVING/INSTALLING THE BOTTOM COWLING ASSEMBLY	37
SWIVEL AND STEERING BRACKET	40
REMOVING/INSTALLING THE SWIVEL AND STEERING BRACKET	40
POWER TILT (PT) UNIT	41
REMOVING/INSTALLING THE POWER TILT (PT) UNIT	41
DISASSEMBLING/ASSEMBLING THE POWER TILT (PT) CYLINDER ...	43
DISASSEMBLING THE POWER TILT (PT) CYLINDER	45
ASSEMBLING THE POWER TILT (PT) CYLINDER	46
DISASSEMBLING/ASSEMBLING THE VALVES AND PUMP 1	50
INSTALLING THE RELIEF VALVE.....	52
DISASSEMBLING/ASSEMBLING THE PT MOTOR.....	53
REMOVING THE ARMATURE	54
CHECKING THE PT MOTOR	54
CHECKING THE PT MOTOR ASSEMBLY	56
INSTALLING THE OIL SEAL	56
DISASSEMBLING/ASSEMBLING THE VALVES AND PUMP 2	57
CLAMP BRACKET	59
REMOVING/INSTALLING THE CLAMP BRACKET	59

ELECTRICAL SYSTEM

ELECTRICAL COMPONENTS.....	61
TOP VIEW AND PORT SIDE VIEW	61
FRONT VIEW (F15AEP/F15PH)	62
FRONT VIEW (F15AHP/F15PH)	63
STARTER MOTOR	64
DISASSEMBLING/ASSEMBLING THE STARTER MOTOR.....	64
REMOVING THE PINION NUT	66
CHECKING THE PINION GEAR	66
CHECKING THE ARMATURE	66
CHECKING THE BRUSH HOLDER.....	67



Item	Unit		Model	
			F15AEP	F15AEHP
			F15PR	F15PH
			F15PR	F15PH
Charge coil resistance (Br-L)		Ω	272 - 408	
Pulser coil resistance (W/G-B)		Ω	234 - 348	
Ignition coil resistance (O-B)		Ω	0.16 - 0.24	
Primary		Ω	0.16 - 0.24	
Secondary		k Ω	3.92 - 5.88	
IGNITION CONTROL SYSTEM				
Oil pressure switch		kPa (kg/cm ² , psi)	14.7 (0.15, 2.13)	
Engine speed limiter				
Rated timing		r/min	6,200	
Ignition off		r/min	6,800	
Reset		r/min	6,000	
STARTING SYSTEM				
Fuse		A	20	
STARTER MOTOR				
Type			Bendix	
Rating		Second	30	
Output		kW	1.1	
Brush length		mm (in)	12.6 (0.5)	
Limit		mm (in)	6.4 (0.25)	
Commutator undercut		mm (in)	2 (0.08)	
Limit		mm (in)	0.8 (0.03)	
CHARGING SYSTEM				
Lighting coil output peak voltage				
V1 (G-G/W)				
@ cranking 1 (500 r/min) open		V	6.5	
@ cranking 2 (500 r/min) loaded		V	6.0	
@ 1,500 r/min		V	21	
@ 3,500 r/min		V	46	
Rectifier output peak voltage				
V2 (R-B)				
@ cranking (500 r/min) open		V	6.0	
@ 1,500 r/min		V	20	
@ 3,500 r/min		V	45	
Charging current		A@ r/min	10 @ 5,000	
Lighting coil resistance (G-G/W)		Ω @20°C (68°F)	0.24 - 0.36	



REMOVING/INSTALLING THE POWER UNIT 1 (F15AEHP/F15PH)

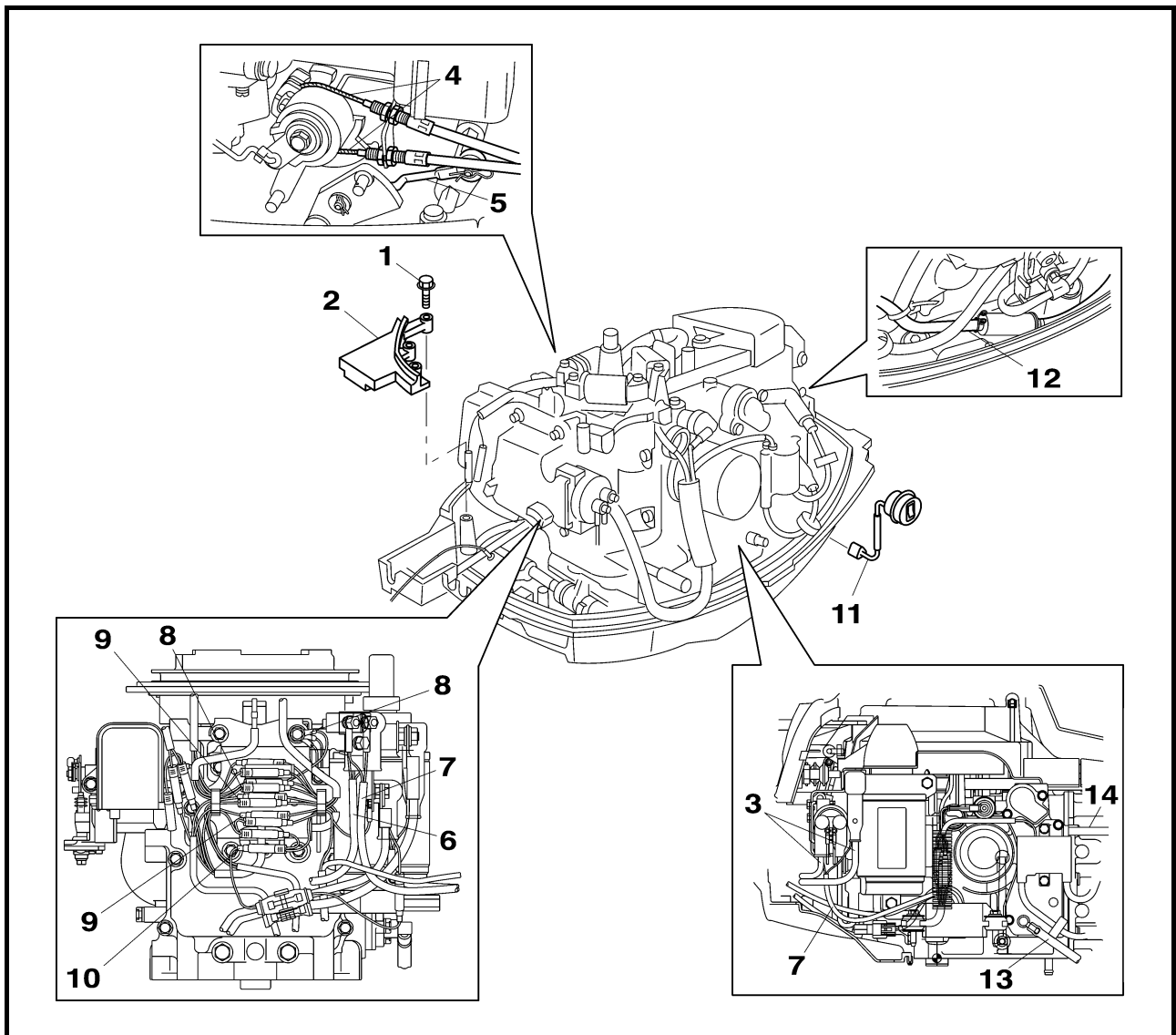

Step	Job/Part	Q'ty	Remarks
1	Bolt	3	
2	Fitting plate	1	
3	Battery cables	1	
4	Throttle cable	2	
5	Shift link rod	1	
6	PT motor lead	1	
7	PT relay lead	2	
8	Engine stop switch lead	1	
9	Neutral switch lead	1	
10	Fuse lead	1	
11	Trailer switch lead	1	(With trailer switch model only)
12	Fuel hose	1	
13	Pilot water hose	1	

Continued on next page.

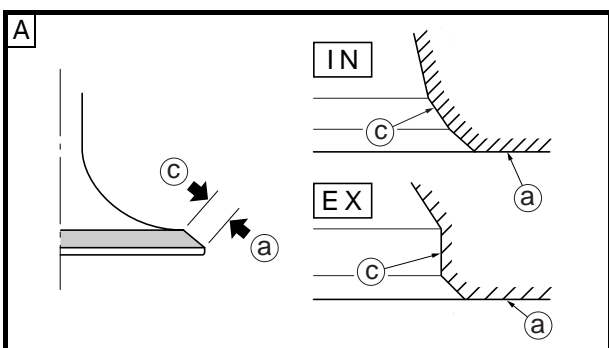
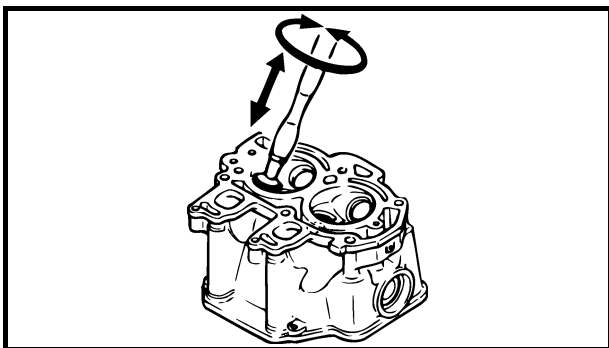
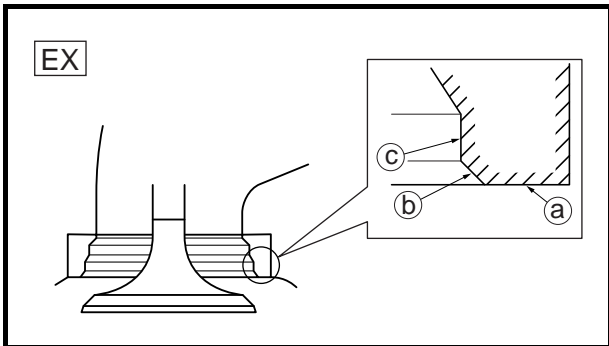
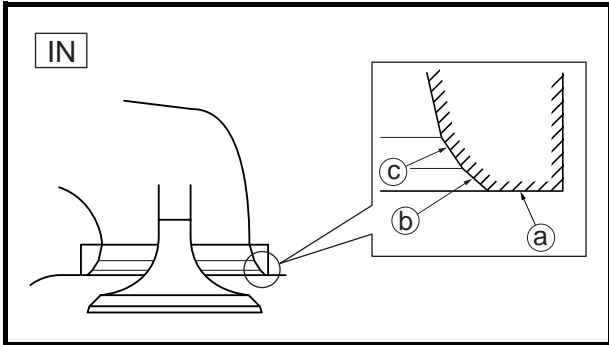

REFACING THE VALVE SEAT

Reface:
 • Valve seat

CAUTION:

When turning the valve seat cutter, keep an even downward pressure (4 - 5 kg) to prevent chatter mark.



Valve seat width
 (intake valve and exhaust valve):
 0.6 - 0.8 mm (0.02 - 0.03 in)



Valve seat cutter set:
 90890-06803
Valve seat cutter:
 90890-06556
Valve seat lapper:
 90890-06805

Cut section and seat cutter

Seat	Cut section	Seat cutter
IN	Ⓐ: 180°	180°: 90890-06556
	Ⓑ: 90°	90°: 90890-06312
	Ⓒ: 60°	60°: 90890-06315
EX	Ⓐ: 180°	170°: 90890-06313
	Ⓑ: 90°	90°: 90890-06312
	Ⓒ: 0°	60°: 90890-06315

NOTE:

After refacing the valve seat, lap the valve seat and valve face.

Refacing steps:

A Valve seat is centered on valve face but it is too wide.

	Valve seat cutter	Desired result
Ⓐ	180° cutter (IN) 170° cutter (EX)	Lap the face Ⓐ and face Ⓒ lightly to reduce the valve seat width.
Ⓒ	60° cutter (IN/EX)	

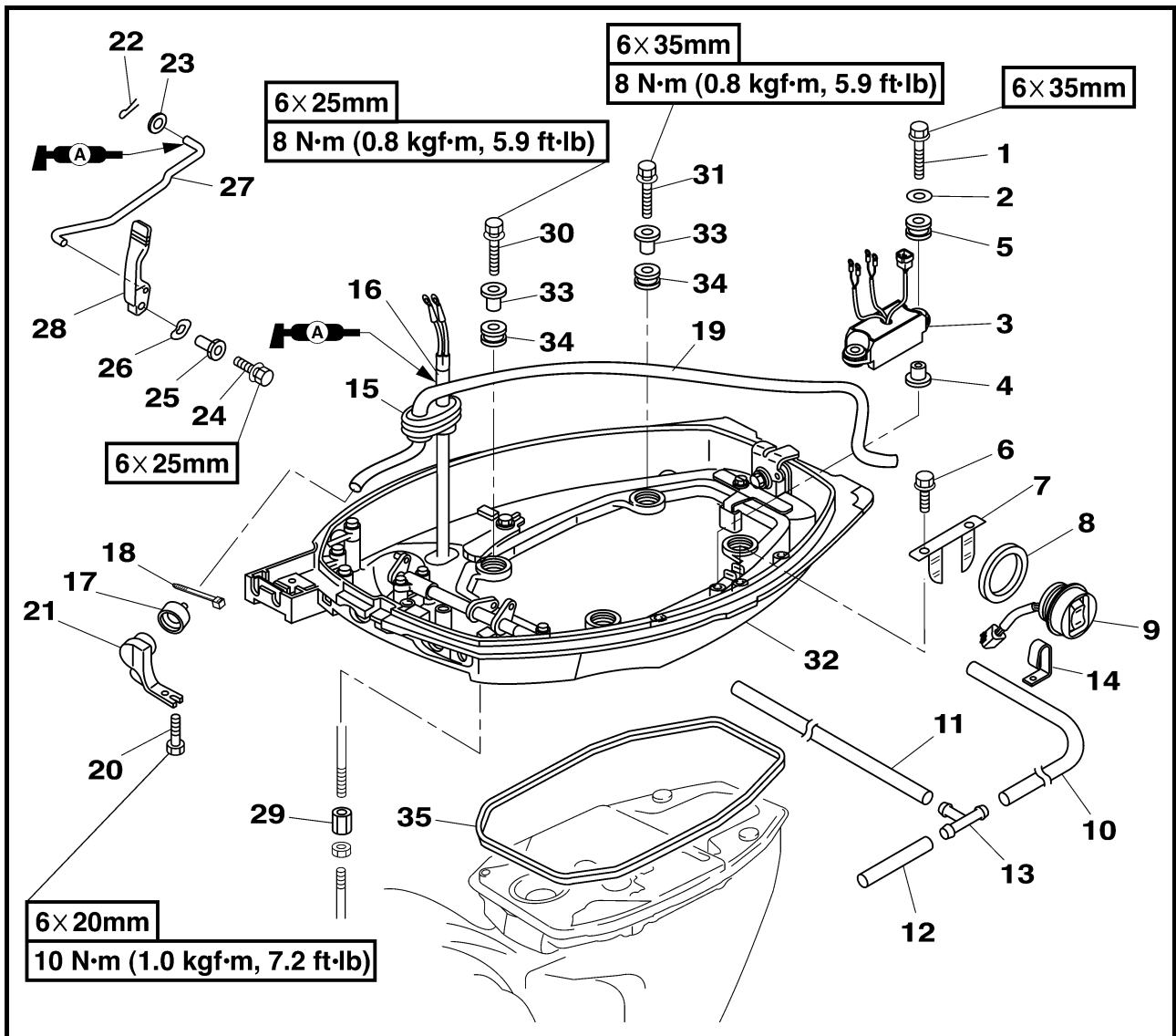

Step	Job/Part	Q'ty	Remarks
27	Shift rod link	1	
28	Gear shift handle	1	
29	Shift rod nut	1	
30	Bolt (with washer)	2	
31	Bolt (with washer)	2	
32	Bottom cowling assembly	1	
33	Collar	4	
34	Grommet	4	
35	Rubber seal	1	
			For installation, reverse the removal procedure.

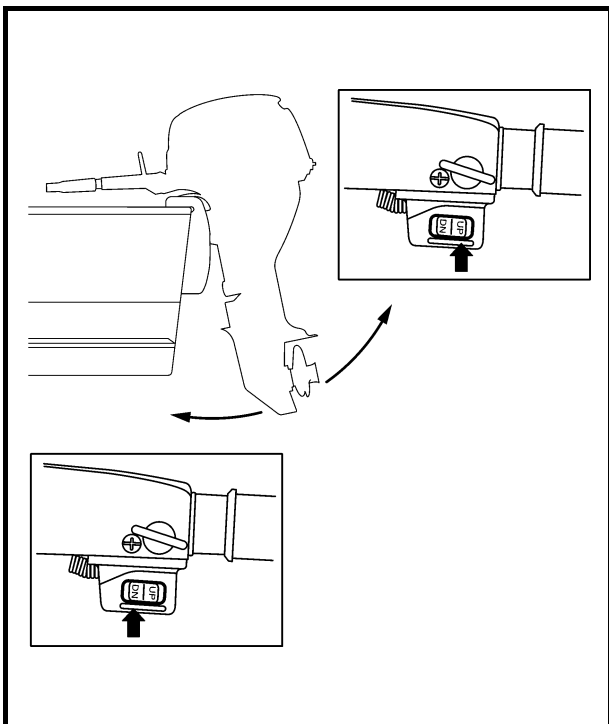
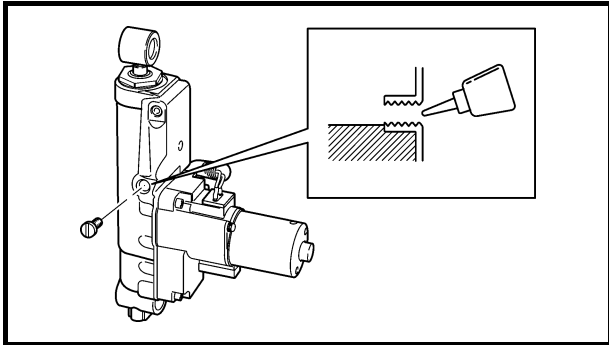
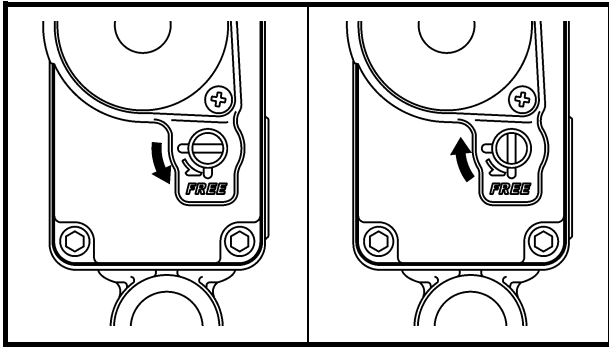

(7) Open the manual valve, leave it to stand for about 1 second and close it.

NOTE:

Check the fluid level and replenish if short.

(8) Leave it to stand for about 3 minutes and then repeat steps (6) and (7).

NOTE:

- Repeat for about 3 times until the up relief sound is confirmed without delay when the cylinder extends.
- Finally confirm the fluid level.

(9) Install the power tilt (PT) unit to the outboard motor.

NOTE:

Carrying and working should be done with the power tilt (PT) unit erected.

(10) Operate the PT switch to move down the tilt, relieve it for about 1 second, and then immediately move up the tilt.

NOTE:

- For moving up the tilt, stop it at about half the stroke.
- If it does not stop, air removal is not complete. Take the steps (6) and (7) with it installed to the outboard motor.
- Immediately after the tilt up, check that the outboard motor does not descend. Finally recheck the operation in this procedure.

(11) Move up the tilt and finally check the fluid level.

NOTE:

If short, replenish.

CLAMP BRACKET REMOVING/INSTALLING THE CLAMP BRACKET

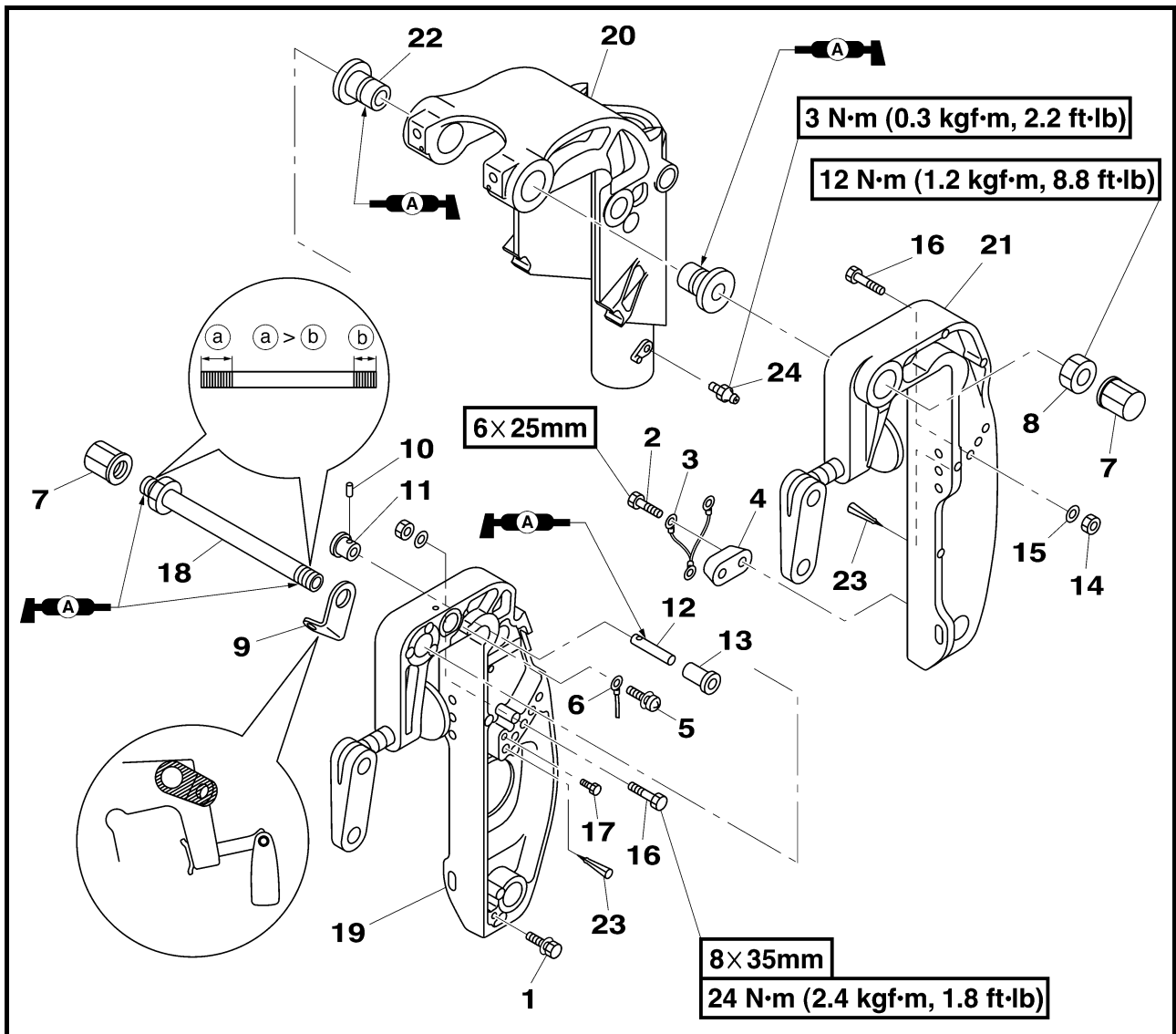

Step	Job/Part	Q'ty	Remarks
1	Bolt (with washer)	1	
2	Bolt	2	
3	Wire lead	1	
4	Anode	1	
5	Screw	1	
6	Wire lead	1	
7	Cap nut	2	
8	Clamp bracket cap	2	
9	Clamp bracket plate	1	
10	Spring pin	1	
11	Stopper knob	1	
12	Stopper shaft	1	
13	Bushing	1	

Continued on next page.

CLICK HERE TO **DOWNLOAD** THE COMPLETE MANUAL

- Thank you very much for reading the preview of the manual.
- You can download the complete manual from: www.heydownloads.com by clicking the link below



- Please note: If there is no response to CLICKING the link, please download this PDF first and then click on it.

CLICK HERE TO **DOWNLOAD** THE COMPLETE MANUAL