



F60TLRC T60TLRC FOUR STROKE

Service Manual



LIT-18616-FT-60

CLICK HERE TO **DOWNLOAD** THE COMPLETE MANUAL

- Thank you very much for reading the preview of the manual.
- You can download the complete manual from: www.heydownloads.com by clicking the link below



- Please note: If there is no response to CLICKING the link, please download this PDF first and then click on it.

CLICK HERE TO **DOWNLOAD** THE COMPLETE MANUAL

Symbols

The symbols below are designed to indicate the content of a chapter.

General information



Power unit



Specifications



Lower unit

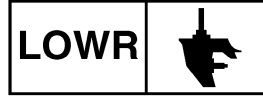

Periodic checks and adjustments



Bracket unit

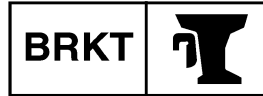

Fuel system



Electrical systems

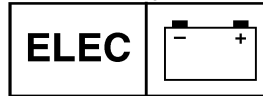

Symbols ① to ⑤ in an exploded diagram indicate the grade of lubricant and the lubrication point.

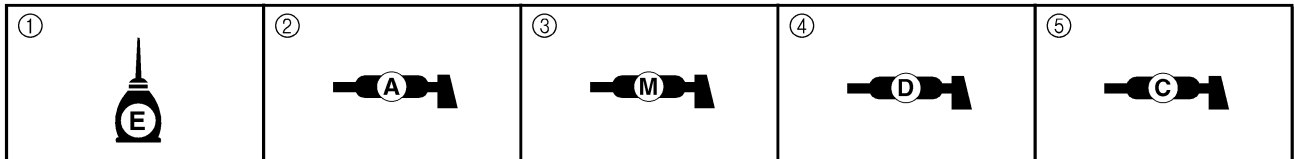

- ① Apply Yamaha 4-stroke motor oil
- ② Apply water resistant grease (Yamaha grease A, Yamaha marine grease)
- ③ Apply molybdenum disulfide grease
- ④ Apply anti-corrosion grease (Yamaha grease D)
- ⑤ Apply low temperature resistant grease (Yamaha grease C)

Symbols ⑥ to ⑪ in an exploded diagram indicate the type of sealant or locking agent and the application point.

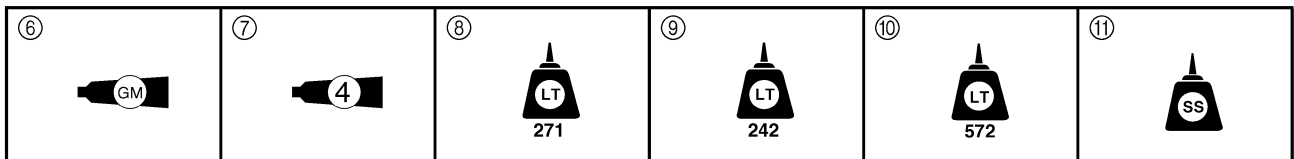

- ⑥ Apply Gasket Maker®
- ⑦ Apply Yamabond No. 4
- ⑧ Apply LOCTITE® No. 271 (Red LOCTITE)
- ⑨ Apply LOCTITE® No. 242 (Blue LOCTITE)
- ⑩ Apply LOCTITE® No. 572
- ⑪ Apply silicon sealant

Specifications

General specifications	2-1
Maintenance specifications	2-3
Power unit.....	2-3
Lower unit.....	2-7
Electrical	2-7
Dimensions.....	2-11
Tightening torques	2-14
Specified torques.....	2-14
General torques.....	2-16



— MEMO —



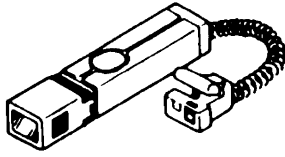

Timing light
90890-03141

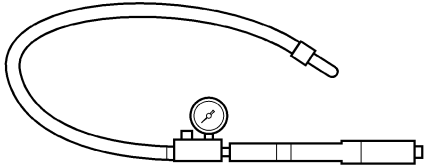

Leakage tester
90890-06762



2. Clean the electrodes ① with a spark plug cleaner or wire brush. Replace the spark plug if necessary.

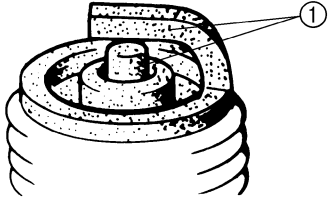

S62Y3260

3. Check the electrodes for erosion and excessive carbon or other deposits, and the gasket for damage. Replace the spark plug if necessary.
4. Check the spark plug gap ②. Adjust if out of specification.

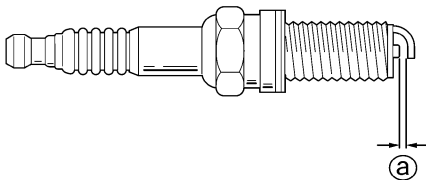

S62Y3270

Specified spark plug: DPR6EA-9 (NGK)

Spark plug gap ②:
0.8–0.9 mm (0.031–0.035 in)

5. Install the spark plug, tighten it finger tight ③, then to the specified torque with a spark plug wrench ④.

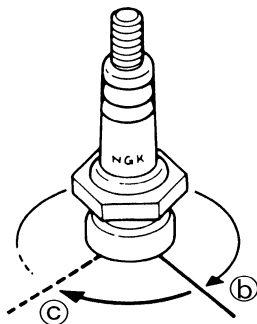

S62Y3280

Spark plug: 25 N·m (2.5 kgf·m, 18 ft·lb)

Checking the thermostat

1. Remove the cover ①, thermostat cover ②, and thermostat ③.

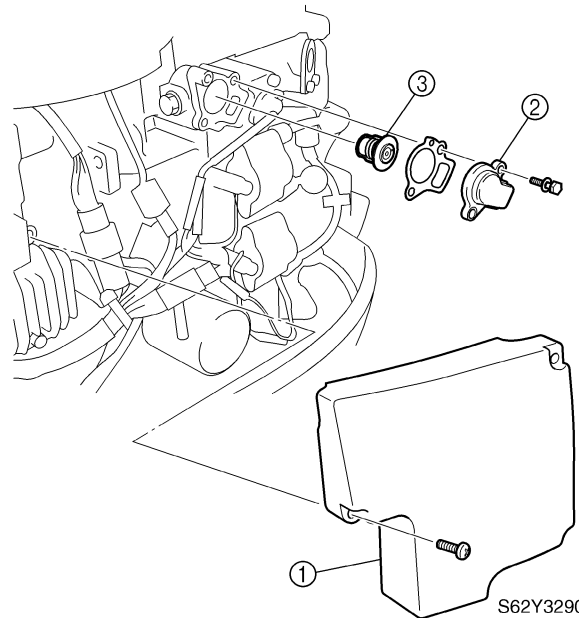

S62Y3290

2. Suspend the thermostat in a container of water.
3. Place a thermometer in the water and slowly heat the water.

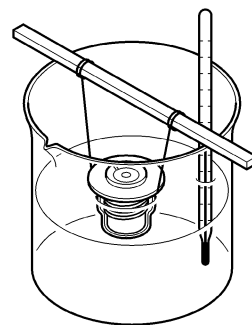

S62Y3300

3

NOTE:
Apply grease to the grease nipple until it flows from the bushings ①.

2. Apply anti-corrosion grease to the areas shown.

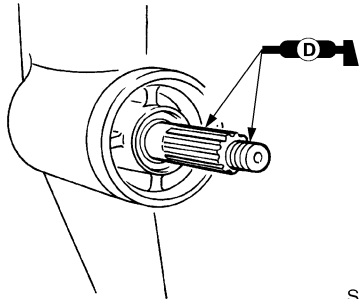

S62Y3730

Fuel filter and fuel pump

No.	Part name	Q'ty	Remarks	Tightening torques			
				Stage	N·m	kgf·m	ft·lb
1	Fuel filter cup	1					
2	O-ring	1	Not reusable				
3	Fuel filter element	1					
4	Body	1					
5	Float	1					
6	Screw	4	M5 × 35 mm				
7	Cover	1					
8	Fuel pump body 2	1					
9	Fuel pump body 1	1					
10	Nut	4					
11	Plunger	1					
12	Spring	1					
13	Spring	1					
14	Pin	1					
15	Diaphragm	1					
16	Screw	2	M3 × 6 mm				
17	Valve	2					
18	Nut	2					
19	Seal	1	Not reusable				
20	Gasket	1	Not reusable				

Ⓐ F50/F50A

Ⓑ T50/FT50B, FT50C

4

Carburetor

No.	Part name	Q'ty	Remarks	Tightening torques			
				Stage	N·m	kgf·m	ft·lb
1	Carburetor body	1					
2	Screw	4	M4 × 13 mm				
3	Cover	1					
4	Seal	1	Not reusable				
5	Pilot jet	1					
6	Main jet	1					
7	Needle valve	1					
8	Main nozzle	1					
9	O-ring	1	Not reusable				
10	Plug	1					
11	Float	1					
12	Screw	1	M4 × 6 mm				
13	Float pin	1					
14	Gasket	1	Not reusable				
15	Float chamber	1					
16	Drain screw	1					
17	O-ring	1	Not reusable				
18	Screw	4	M4 × 13 mm				
19	Fuel hose	1	Float chamber-to-body				
20	Prime Start	1					
21	Screw	1	M4 × 7 mm				
22	O-ring	1	Not reusable				
23	Bracket	1					
24	Body	1					
25	Screw	2	Carburetor #1: M4 × 17 mm Carburetor #3: M4 × 22 mm				
26	Gasket	1	Not reusable				

A Carburetors #1, #2, and #3

B Carburetor #4

C Carburetors #1 and #3

4

Cylinder body	5-51
Removing and installing the oil filter	5-55
Disassembling the cylinder body	5-55
Checking the piston diameter	5-56
Checking the cylinder bore	5-56
Checking the piston clearance	5-57
Checking the piston rings	5-57
Checking the piston ring grooves	5-58
Checking the piston ring side clearance	5-58
Checking the piston pin boss bore	5-58
Checking the piston pin	5-58
Checking the connecting rod small end inside diameter	5-59
Checking the connecting rod big end side clearance	5-59
Checking the connecting rod bolt	5-59
Checking the crankshaft	5-59
Checking the crankshaft main journal oil clearance	5-60
Checking the crankshaft pin oil clearance	5-61
Selecting the crankshaft main journal bearing.....	5-62
Selecting the connecting rod big end bearing	5-63
Assembling the cylinder body.....	5-64
Installing the power unit.....	5-67

Special service tools

For USA and Canada

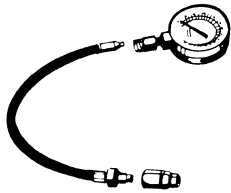

Compression gauge
YU-33223-1

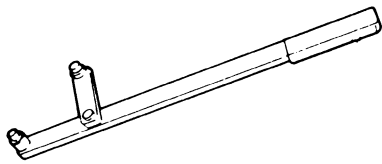

Flywheel magnet holder
YB-06139

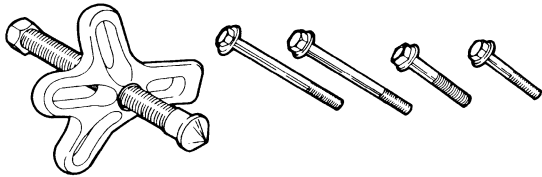

Universal puller
YB-06117

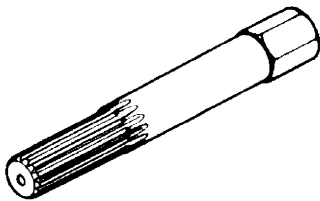

Crankshaft holder
YB-06562

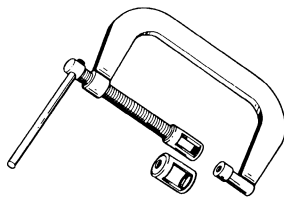

Valve spring compressor
YM-01253

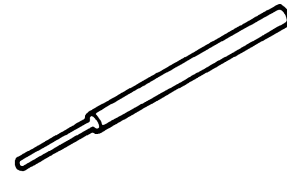

Valve guide remover
YM-01122

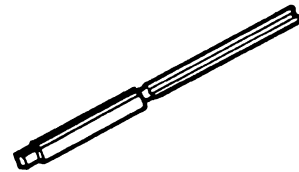

Valve guide reamer
YM-01196

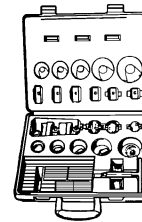

Valve seat cutter set
YM-91043-C

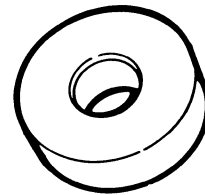

Drive shaft needle bearing depth stop
YB-34473

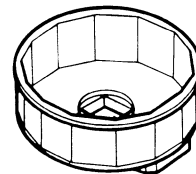

Oil filter wrench
YU-38411

Power unit

No.	Part name	Q'ty	Remarks	Tightening torques			
				Stage	N·m	kgf·m	ft·lb
1	Bracket	1					
2	Starter motor	1					
3	Spark plug cap	4					
4	Ignition coil	2					
5	Wiring harness	1					
6	Thermoswitch	1					
7	Holder	1					
8	Bolt	1	M6 × 12 mm				
9	Ground lead	3					
10	Bolt	1	M6 × 12 mm				
11	Oil pressure switch	1			9	0.9	6.5
12	Oil pressure switch lead	1					
13	Screw	1			2	0.2	1.4
14	Ignition coil lead	2					
15	Bolt	4	M6 × 30 mm		7	0.7	5.1
16	Thermoswitch lead	2					
17	Rectifier Regulator coupler	1					
18	CDI unit coupler	1					
19	Bolt	2	M8 × 25 mm		30	3.0	22
20	Bolt	3	M8 × 35 mm				
21	Nut	1					
22	Spring washer	1					
23	Starter motor lead	1					
24	Spring washer	1					
25	Nut	1			7	0.7	5.1
26	Bolt	1	M8 × 45 mm		30	3.0	22

5

Timing belt and sprockets

No.	Part name	Q'ty	Remarks	Tightening torques			
				Stage	N·m	kgf·m	ft·lb
1	Timing belt	1					
2	Drive sprocket	1					
3	Driven sprocket	1					
4	Bolt	1			8	0.8	5.8
5	Bolt	1	M8 × 20 mm		25	2.5	18
6	Tensioner	1					
7	Spring	1					
8	Nut	1			140	14	101
9	Retaining plate	2					
10	Woodruff key	1					
11	Bolt	1	M10 × 40 mm		38	3.8	28
12	Washer	1					
13	Bolt	2	M6 × 20 mm				
14	Blowby hose	1					
15	Clip	1					
16	Dowel pin	1					

5

- Remove the retaining bolt ④, then the camshaft ⑤ by pulling it downward.

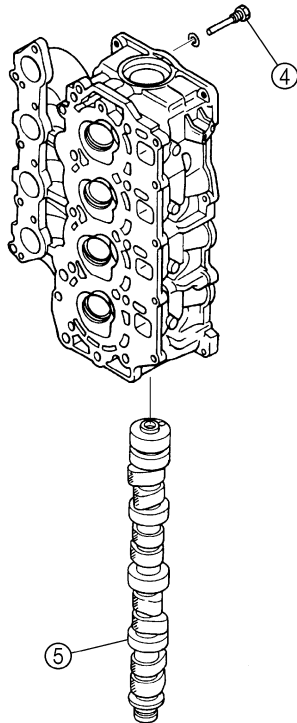

S62Y5280

- Remove the intake valve and exhaust valves.

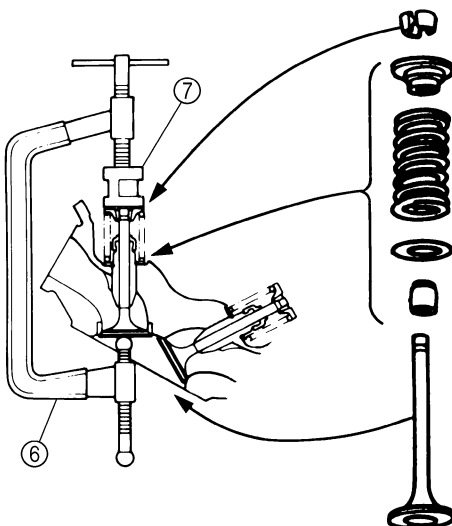

S62Y5290

NOTE:
When replacing the valve, also replace the valve guide and stem seal.

Valve spring compressor ⑥:

YM-01253 / 90890-04019

Valve spring compressor attachment ⑦:

90890-06320

Checking the valve springs

- Measure the valve spring free length ①. Replace if out of specification.

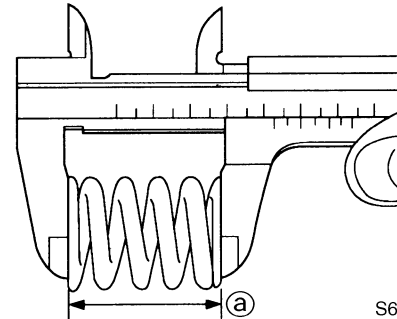

S62Y5300

Valve spring free length limit ①:

37.85 mm (1.490 in)

- Measure the valve spring tilt ②. Replace if out of specification.

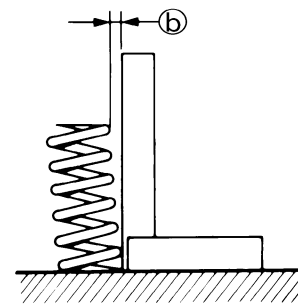

S62Y5310

Valve spring tilt limit ②: 1.7 mm (0.07 in)

Checking the valves

- Check the valve face for pitting or wear. Replace if necessary.

5

2. Tighten the cylinder head bolts to the specified torques in two stages and in the sequence shown.

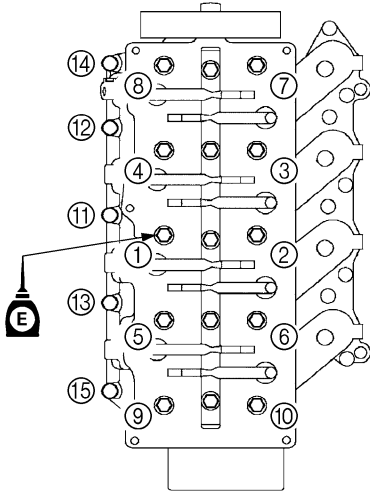

S62Y5670

- NOTE:** _____
Apply engine oil to the cylinder head bolts (M9) before installation.

Cylinder head bolt (M9):

1st: 23 N·m (2.3 kgf·m, 17 ft·lb)

2nd: 47 N·m (4.7 kgf·m, 34 ft·lb)

Cylinder head bolt (M6):

1st: 6 N·m (0.6 kgf·m, 4.3 ft·lb)

2nd: 12 N·m (1.2 kgf·m, 8.7 ft·lb)

3. Tighten the cylinder head cover bolts in the sequence shown.

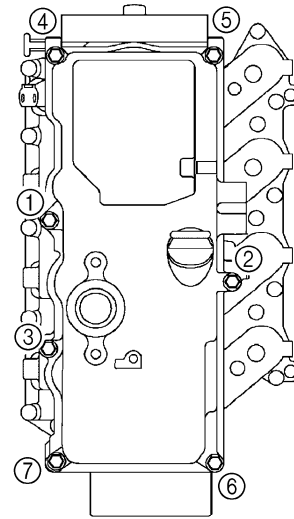

S62Y5680

2. Measure the crankshaft runout. Replace the crankshaft if out of specification.

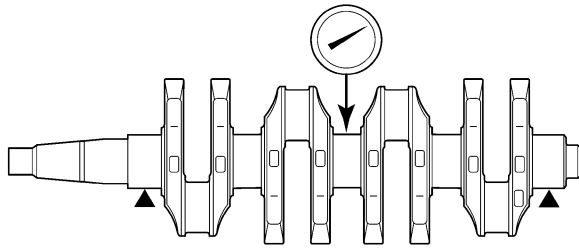

S62Y5870

Crankshaft runout limit:
0.03 mm (0.0012 in)

Checking the crankshaft main journal oil clearance

1. Clean the bearings, main journals, and bearing portions of the crankcase and cylinder body.
2. Place the cylinder body upside down on a bench.
3. Install half of the bearings ① and the crankshaft ② into the cylinder body ③.

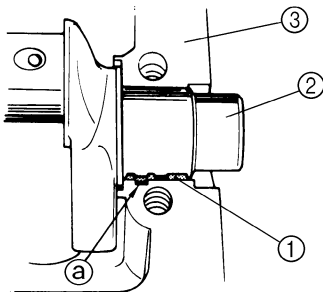

S62Y5910

CAUTION:

Install the bearings in their original positions.

NOTE:

Insert the projection ① of the bearing into the notch in the cylinder body.

4. Put a piece of Plastigauge® (PG-1) on each main journal parallel to the crankshaft.

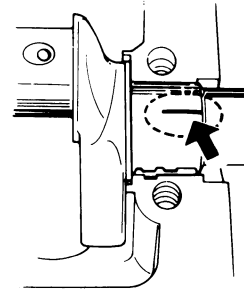

S62Y5920

NOTE:

Do not put the Plastigauge (PG-1) over the oil hole in the main journals of the crankshaft.

5. Install the remaining half of the bearings into the crankcase.

NOTE:

Insert the projection of the bearing into the notch in the crankcase.

6. Install the crankcase onto the cylinder body and apply engine oil onto the threads of the crankcase bolts.
7. Tighten the crankcase bolts to the specified torques in two stages and in the sequence shown.

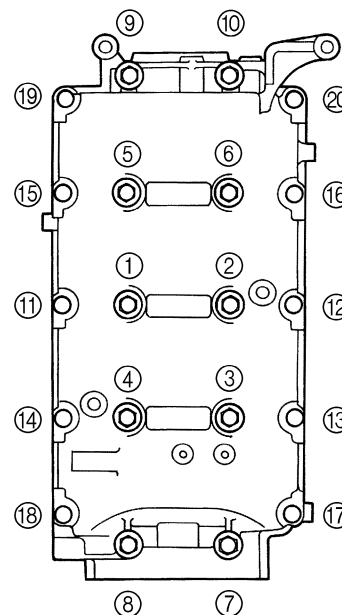

S62Y5930

— MEMO —

5

Lower unit (F50/F50A)

No.	Part name	Q'ty	Remarks	Tightening torques			
				Stage	N·m	kgf·m	ft·lb
1	Lower unit	1					
2	Plastic tie	1	Not reusable				
3	Hose	1					
4	Check screw	1			7	0.7	5.1
5	Gasket	2	Not reusable				
6	Bolt	4	M10 × 40 mm		40	4.0	29
7	Drain screw	1			7	0.7	5.1
8	Dowel pin	2					
9	Bolt	1	M8 × 35 mm				
10	Anode	1					
11	Bolt	1	M8 × 60 mm				
12	Thrust washer	1					
13	Propeller	1					
14	Washer	1					
15	Washer	1					
16	Cotter pin	1	Not reusable				
17	Propeller nut	1			35	3.5	25
18	Trim tab	1					
19	Bolt	1	M8 × 20 mm				

Water pump and propeller shaft housing (F50/F50A)

Installing the propeller shaft housing

1. Install the washer ①, propeller shaft assembly ②, and shift plunger ③, into the propeller shaft housing assembly ④.
2. Apply grease to the new O-rings.

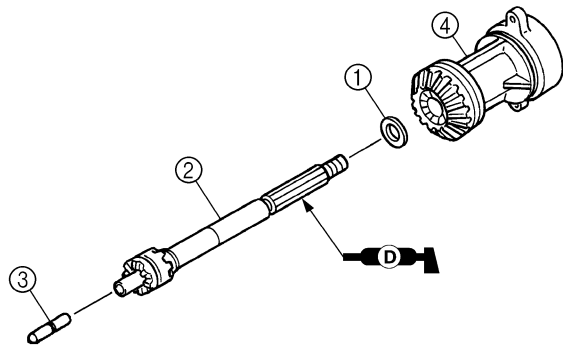

S62Y6180

3. Install the propeller shaft housing assembly into the lower case ⑤, and then tighten the bolts ⑥.

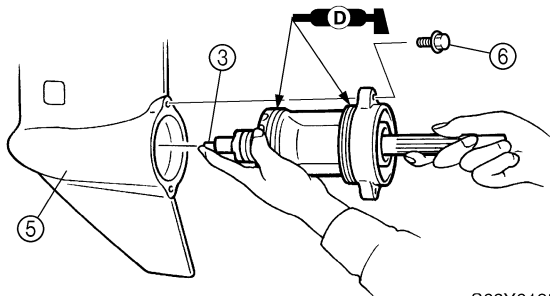

S62Y6185

NOTE: _____
When installing the propeller shaft assembly, be sure not to drop the shift plunger ③.

Installing the water pump

1. Install the new gasket and outer plate cartridge.
2. Install the Woodruff key into the drive shaft.
3. Align the groove on the impeller ① with the Woodruff key ②, and then install it to the drive shaft.

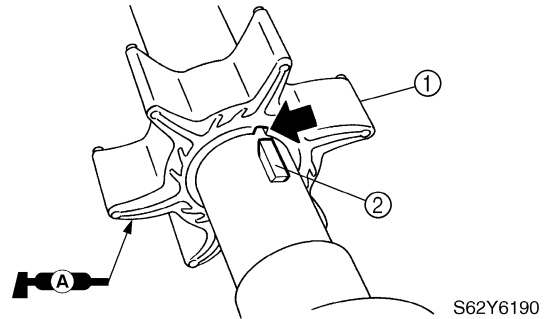

S62Y6190

4. Install the insert plate cartridge ③ into the water pump housing ④.

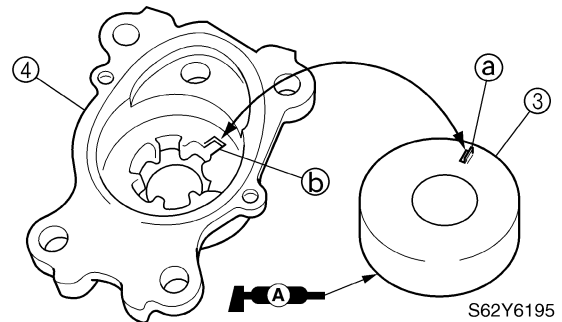

S62Y6195

NOTE: _____
Align the projection ③ of the insert plate cartridge with the hole ④ in the pump housing.

Drive shaft and lower case (F50/F50A)

2. Install the new oil seals to the oil seal housing as shown.

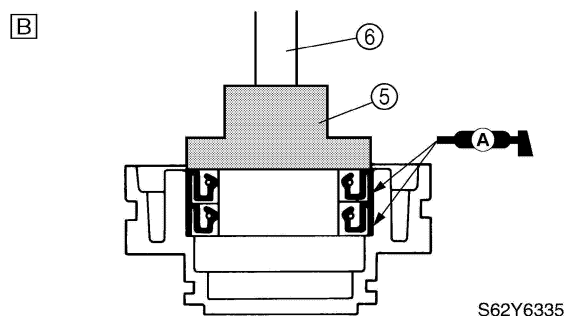
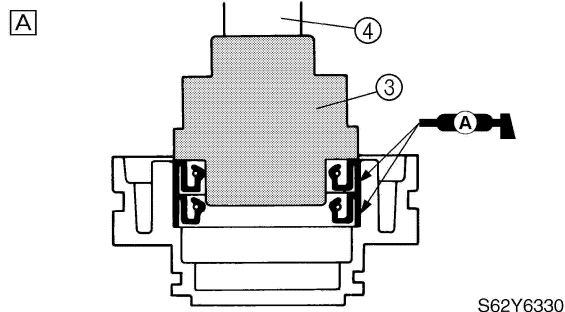

- [A] For USA and Canada
[B] For worldwide

Oil seal installer ③: YB-06168
Driver handle ④: YB-06071
Needle bearing attachment ⑤:
90890-06653
Driver rod L3 ⑥: 90890-06652

Installing the drive shaft

1. Install the forward gear, then the drive shaft assembly, pinion, and pinion nut, and then tighten the nut to the specified torque.

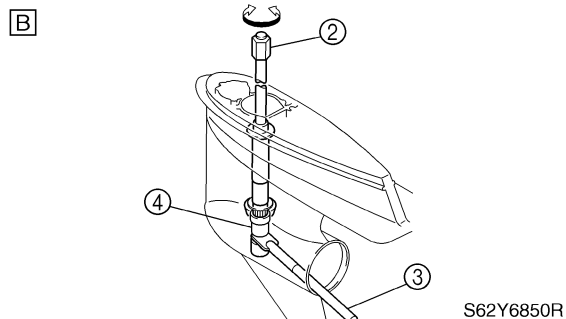
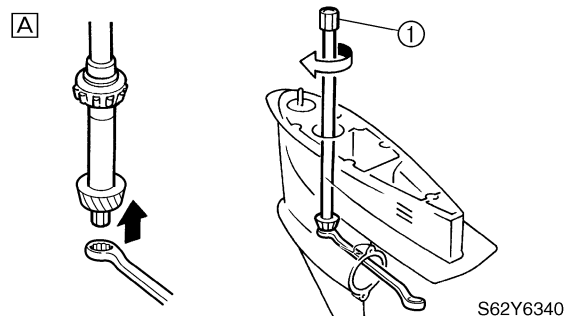

- [A] For USA and Canada
[B] For worldwide

Drive shaft holder ①: YB-06049
Drive shaft holder 4 ②: 90890-06518
Pinion nut holder ③: 90890-06505
Socket adapter 1 ④: 90890-06506

Pinion nut: 75 N·m (7.5 kgf·m, 54 ft·lb)

Installing the lower unit

1. Set the gearshift to the neutral position at power unit and lower unit.

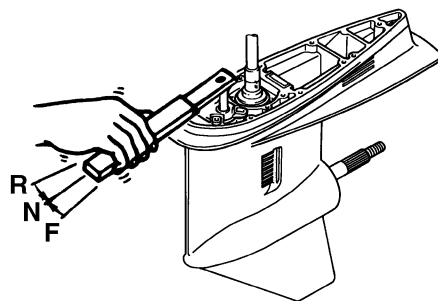
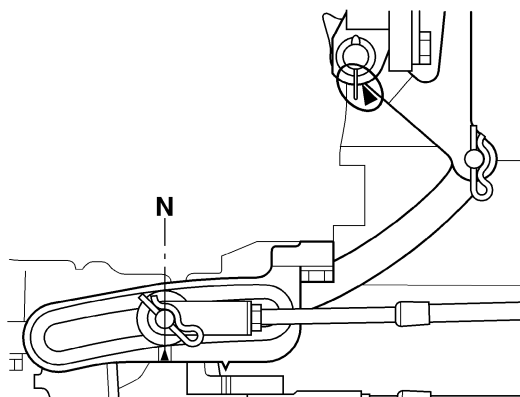

6

Shimming (F50A) (for worldwide)

Example:

If “M” is “22.45 mm” and “F” is “+5”, then

$$T1 = 22.75 + (+5)/100 - 22.45\text{mm} \\ = 0.30 + 0.05 \text{ mm} = 0.35 \text{ mm}$$

If “M” is “22.45 mm” and “F” is “-5”, then

$$T1 = 22.75 + (-5)/100 - 22.45\text{mm} \\ = 0.30 - 0.05 \text{ mm} = 0.25 \text{ mm}$$

3. Select the forward gear shim(s) (T1) as follows.

Calculated numeral at 1/100 place	Rounded numeral
1, 2	0
3, 4, 5	2
6, 7, 8	5
9, 10	8

Available shim thicknesses:

0.10, 0.12, 0.15, 0.18, 0.30, 0.40, and 0.50 mm

Example:

If “T1” is “0.45 mm”, then forward gear shim is 0.42 mm.

If “T1” is “0.50 mm”, then forward gear shim is 0.48 mm.

Selecting the reverse gear shims

1. Measure the backlash to find the shim thickness (T2). Add or remove shims if out of specification. For measuring procedures, see “Measuring the forward and reverse backlash” in this chapter.

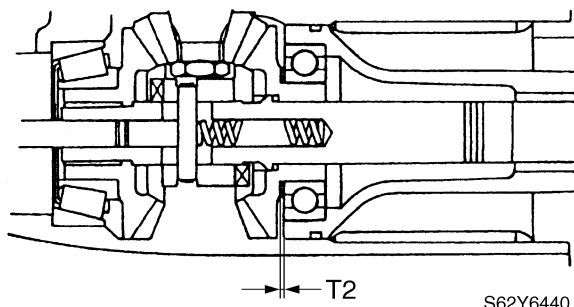

NOTE: Measure the backlash with the original shim(s). If the original shim(s) is unavailable, start with a 0.50 mm shim.

Available shim thicknesses:

0.10, 0.12, 0.15, 0.18, 0.30, 0.40, and 0.50 mm

Water pump and shift rod (T50/FT50B, FT50C)

Installing the water pump and shift rod

1. Install the shift rod assembly ①.

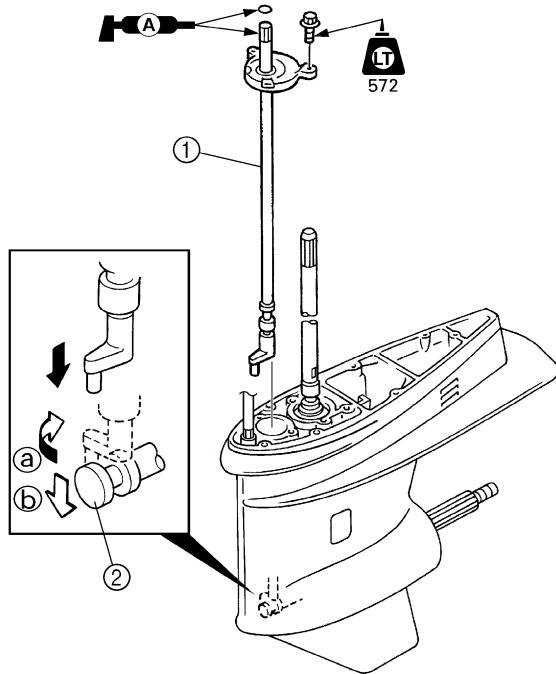

S62Y6555

NOTE:

Install the shift rod assembly into the lower case, turn it clockwise 90° (a), and then push it down (b) to connect it to the shift slider (2).

2. Install the new oil seals into the oil seal housing as shown.

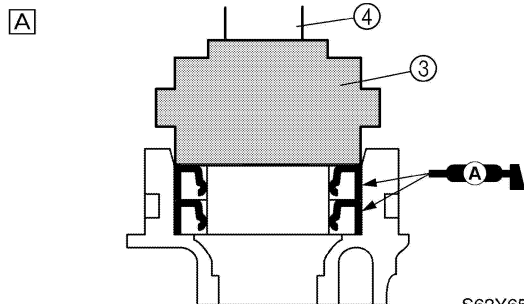

S62Y6560R

(B)

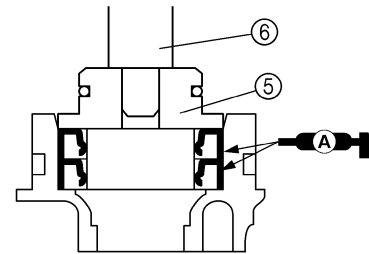

S62Y6565

- (A) For USA and Canada
- (B) For worldwide

Bearing housing oil seal installer (3):
 YB-06269
 Driver handle (4): YB-06071
 Needle bearing attachment (5):
 90890-06610
 Driver rod L3 (6): 90890-06652

3. Install the new O-ring (7).
4. Install the new gasket (8), oil seal housing (9), new gasket (10), and outer plate cartridge (11).

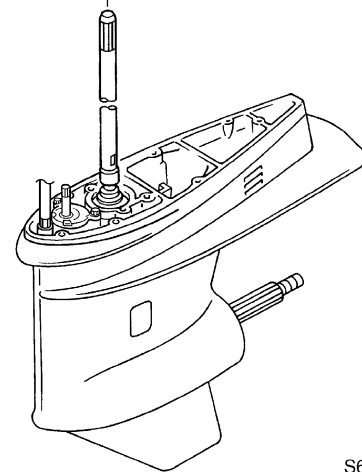
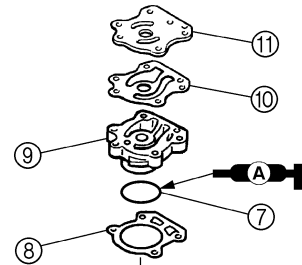

S62Y6570

5. Install the Woodruff key into the drive shaft.

6

Propeller shaft housing (T50/FT50B, FT50C)

Gland nut wrench ⑧: YB-34447
Ring nut wrench 3 ③: 90890-06511
Ring nut wrench extension ⑨:
90890-06513

Ring nut ⑦: 105 N·m (10.5 kgf·m, 76 ft·lb)

Drive shaft and lower case (T50/FT50B, FT50C)

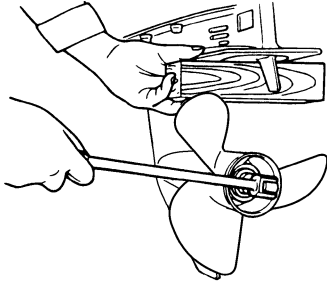

S62Y6520

⚠ WARNING

Do not hold the propeller with your hands when loosening or tightening it. Be sure to remove the battery leads from the batteries and the engine stop lanyard switch. Put a block of wood between the cavitation plate and propeller to keep the propeller from turning.

NOTE:

If the grooves in the propeller nut ④ do not align with the cotter pin hole, tighten the nut until they are aligned.

Propeller nut ④:
35 N·m (3.5 kgf·m, 25 ft·lb)

CLICK HERE TO **DOWNLOAD** THE COMPLETE MANUAL

- Thank you very much for reading the preview of the manual.
- You can download the complete manual from: www.heydownloads.com by clicking the link below



- Please note: If there is no response to CLICKING the link, please download this PDF first and then click on it.

CLICK HERE TO **DOWNLOAD** THE COMPLETE MANUAL

Backlash indicator gauge ⑥: YB-06265
 Backlash indicator ⑥: 90890-06706
 Magnetic plate ⑦: YB-07003
 Magnet base plate ⑦: 90890-07003
 Dial gauge ⑧: YU-03097
 Dial gauge set ⑧: 90890-01252
 Magnet flexible stand ⑨: YU-34481
 Magnet base ⑨: 90890-06705

- Slowly turn the drive shaft clockwise and counterclockwise and measure the backlash when the drive shaft stops in each direction.

Forward gear backlash:
 0.12–0.45 mm (0.005–0.018 in)

- Add or remove shims if out of specification.

Forward gear backlash	Shim thickness
Less than 0.12 mm (0.005 in)	To be decreased by $(0.29 - M) \times 0.57$
More than 0.45 mm (0.018 in)	To be increased by $(M - 0.29) \times 0.57$

M: Measurement

Available shim thicknesses:
 0.10, 0.12, 0.15, 0.18, 0.30, 0.40, and
 0.50 mm

- Remove the special service tools, and then install the water pump assembly.

Tiller handle (F50/F50A, T50/FT50B)

No.	Part name	Q'ty	Remarks	Tightening torques			
				Stage	N·m	kgf·m	ft·lb
31	Nut	2	M8 × 50 mm				
32	Collar	2					
33	Bolt	2					
34	Self-locking nut	1					
35	Bracket	1					
36	Steering lock shaft	1					
37	Steering lock knob	1					
38	Friction plate	1					
39	Friction piece	2					

Tiller handle (FT50C)

No.	Part name	Q'ty	Remarks	Tightening torques			
				Stage	N·m	kgf·m	ft·lb
1	Bolt	1	M8 × 30 mm				
2	Nut	1					
3	Wing nut	1					
4	Friction piece	1					
5	Bolt	1	M6 × 35 mm				
6	Friction rod	1					
7	Washer	1					
8	Nut	1					
9	Washer	2					
10	Link rod	1					
11	Nut	1					
12	Plate	1					
13	Bolt	3	M6 × 20 mm				
14	Grommet	1					
15	Cable guide	1					
16	Grommet	1					
17	Plastic tie	2					
18	Battery lead	1					

7

Bottom cowling

No.	Part name	Q'ty	Remarks	Tightening torques			
				Stage	N·m	kgf·m	ft·lb
31	Bolt	2	Models with trailer switch				
32	Bracket	1	Models with trailer switch				
33	Trailer switch	1	Models with trailer switch				
34	PTT motor lead	1	EHT/ET models				
35	Trim sensor coupler	1	EHT/ET models				
36	Screw	1	M6 × 24 mm EHT/ET models				
37	Grommet	1					
38	Flushing hose	1	Models with flushing device				
39	Adapter	1	Models with flushing device				
40	Bolt	1	M6 × 20 mm Models with flushing device				
41	Rubber seal	1					
42	Hose	1					

Upper case

No.	Part name	Q'ty	Remarks	Tightening torques			
				Stage	N·m	kgf·m	ft·lb
1	Oil seal	1	Not reusable				
2	Exhaust guide	1					
3	Grommet	1					
4	Grommet	1					
5	Anode	1					
6	Cover	1					
7	Bolt	1					
8	Cover	1					
9	Bolt	1					
10	Gasket	1	Not reusable				
11	Dowel pin	2					
12	Bolt	10	M6 × 25 mm				
13	Oil pan	1					
14	Gasket	1	Not reusable				
15	Exhaust manifold	1					
16	Bolt	1	M6 × 45 mm				
17	Gasket	1	Not reusable				
18	Gasket	1	Not reusable				
19	Bolt	6	M6 × 25 mm				
20	Muffler	1					
21	Gasket	1	Not reusable				
22	Pipe	1					
23	Rubber seal	1	Not reusable				
24	Gasket	1	Not reusable				
25	Relief valve housing	1					
26	Bolt	2	M6 × 25 mm				
27	Bolt	2	M6 × 16 mm				
28	Bolt	1	M6 × 25 mm				
29	Oil strainer	1					
30	Relief valve	1					
31	Spring	1					
32	Cotter pin	1	Not reusable				



Swivel bracket and steering arm

No.	Part name	Q'ty	Remarks	Tightening torques			
				Stage	N·m	kgf·m	ft·lb
1	Steering arm	1					
2	Washer	1					
3	Bushing	1					
4	O-ring	2	Not reusable				
5	Bushing	2					
6	Swivel bracket	1					
7	Bushing	1					
8	Port tilt stop lever	1					
9	Circlip	1					
10	Steering yoke	1					
11	Bushing	1					
12	Bushing	1					
13	Tilt stop lever joint	1					
14	Spring holder	1					
15	Bolt	1	M6 × 10 mm				
16	Spring	1					
17	Bushing	1					
18	Pin	2					
19	Bushing	1					
20	Starboard tilt stop lever	1					

Trim cylinder

No.	Part name	Q'ty	Remarks	Tightening torques			
				Stage	N·m	kgf·m	ft·lb
1	Tilt ram	1					
2	Dust seal	1	Not reusable				
3	Backup ring	1					
4	O-ring	1	Not reusable				
5	Tilt cylinder end screw	1					
6	O-ring	1	Not reusable				
7	Backup ring	1					
8	O-ring	1	Not reusable				
9	Trim cylinder end screw	1			80	8.0	58
10	O-ring	1	Not reusable				
11	O-ring	1	Not reusable				
12	Trim piston	1					
13	O-ring	1	Not reusable				
14	Trim cylinder	1					
15	O-ring	1	Not reusable				
16	Backup ring	1					
17	Ball	1					
18	Tilt piston	1					
19	Ball	4					
20	Absorber valve pin	4					
21	Spring	4					
22	Pin	4					
23	Pin	2					
24	Washer	1					
25	Bolt	1	M12 × 45 mm		61	6.1	44

10. Install the joint ⑳ and power trim and tilt motor ㉑ by installing the bolts ㉒, then tightening them to the specified torque.

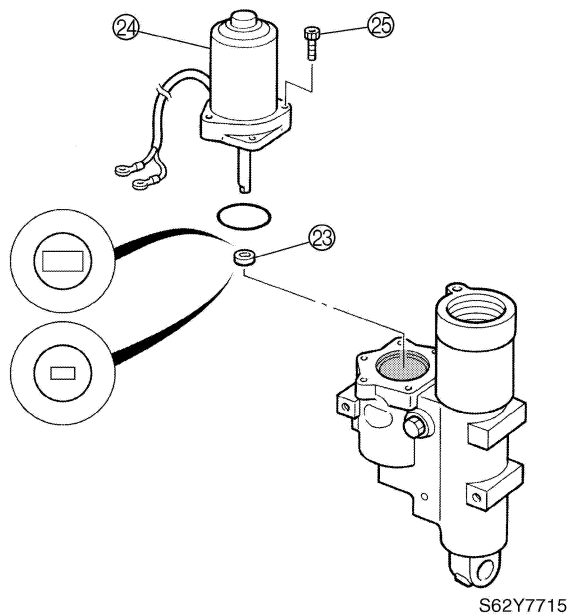

PTT motor bolt ㉒:
4 N·m (0.4 kgf·m, 2.9 ft·lb)

Assembling the trim cylinder

1. Install the dust seal ① into the tilt cylinder end screw ②.
2. Install the O-ring ③ to the end screw.
3. Install the tilt ram ④ into the end screw.

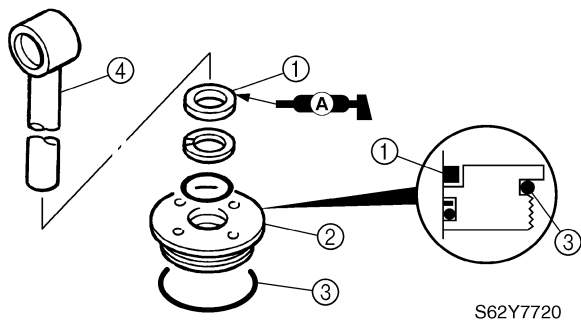

4. Install the backup ring ⑤ and O-rings ⑥ and ⑦ into the trim cylinder end screw ⑧.

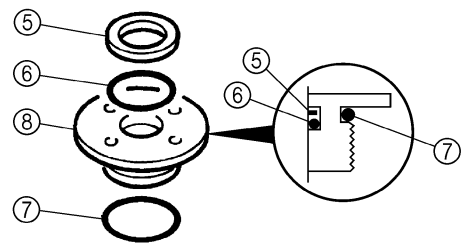

S62Y7730

5. Install the trim cylinder end screw onto the tilt ram.

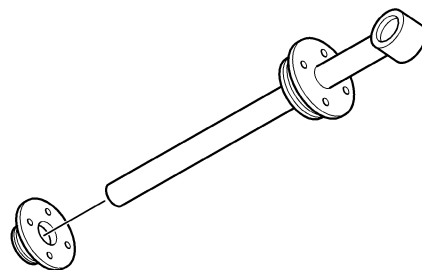

S62Y7740

6. Install O-rings ⑨ and ⑩ onto the trim piston ⑪, and then install the trim piston to the trim cylinder ⑫.

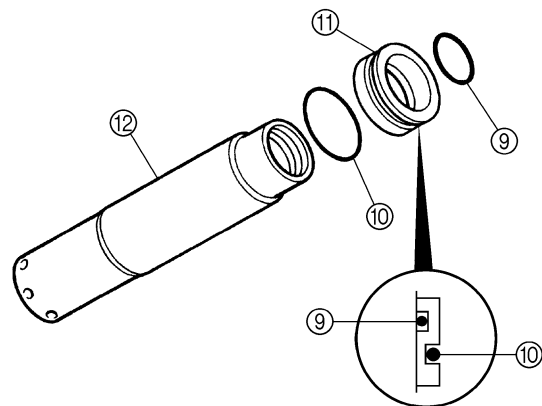

S62Y7750

Power trim and tilt motor / Power trim and tilt electrical system

Power trim and tilt electrical system

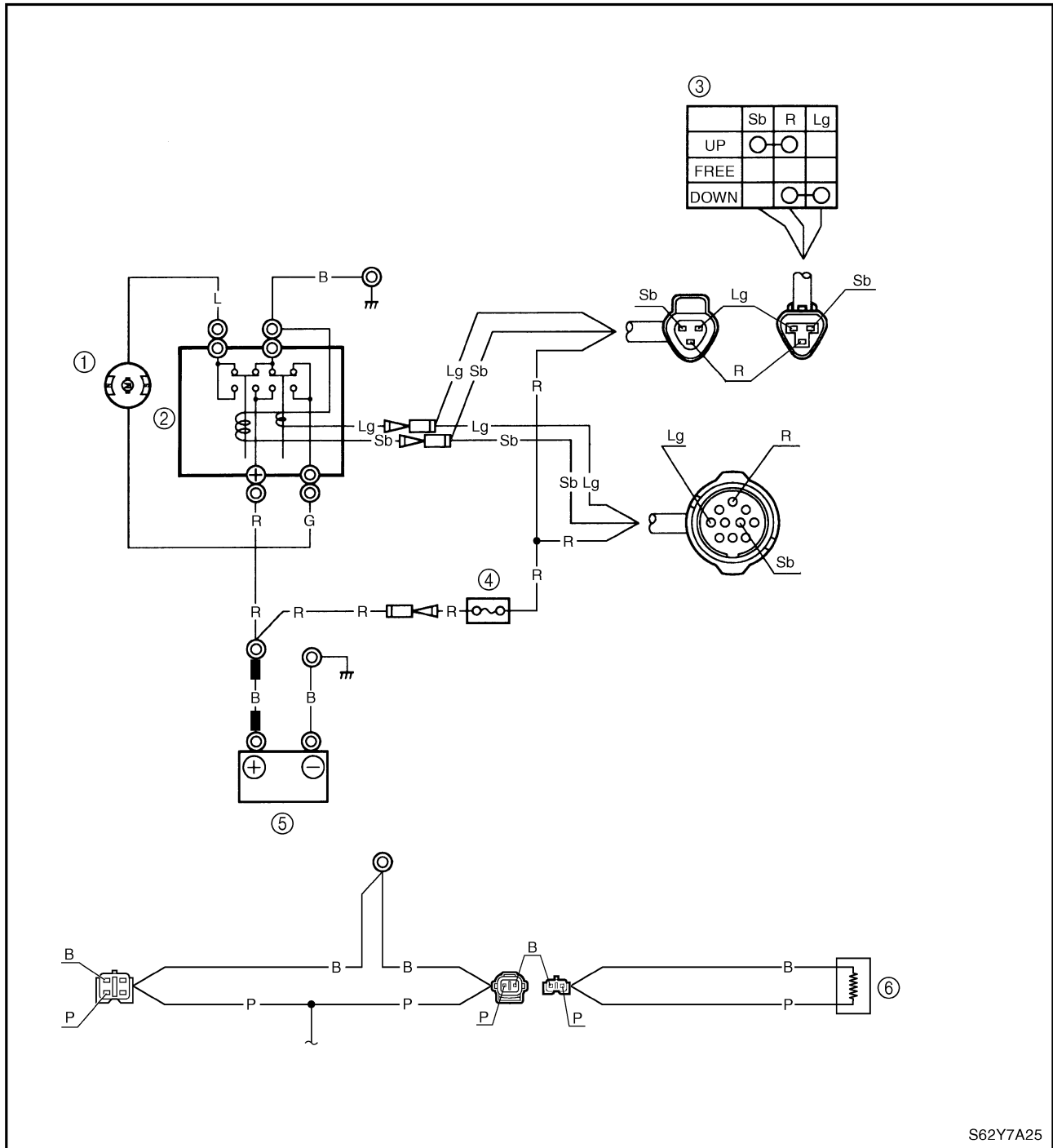

S62Y7A25

- ① Power trim and tilt motor
- ② Power trim and tilt relay
- ③ Power trim and tilt switch
- ④ Fuse
- ⑤ Battery
- ⑥ Trim sensor

- B : Black
- G : Green
- L : Blue
- Lg : Light green
- P : Pink
- R : Red
- Sb : Sky blue



Front view

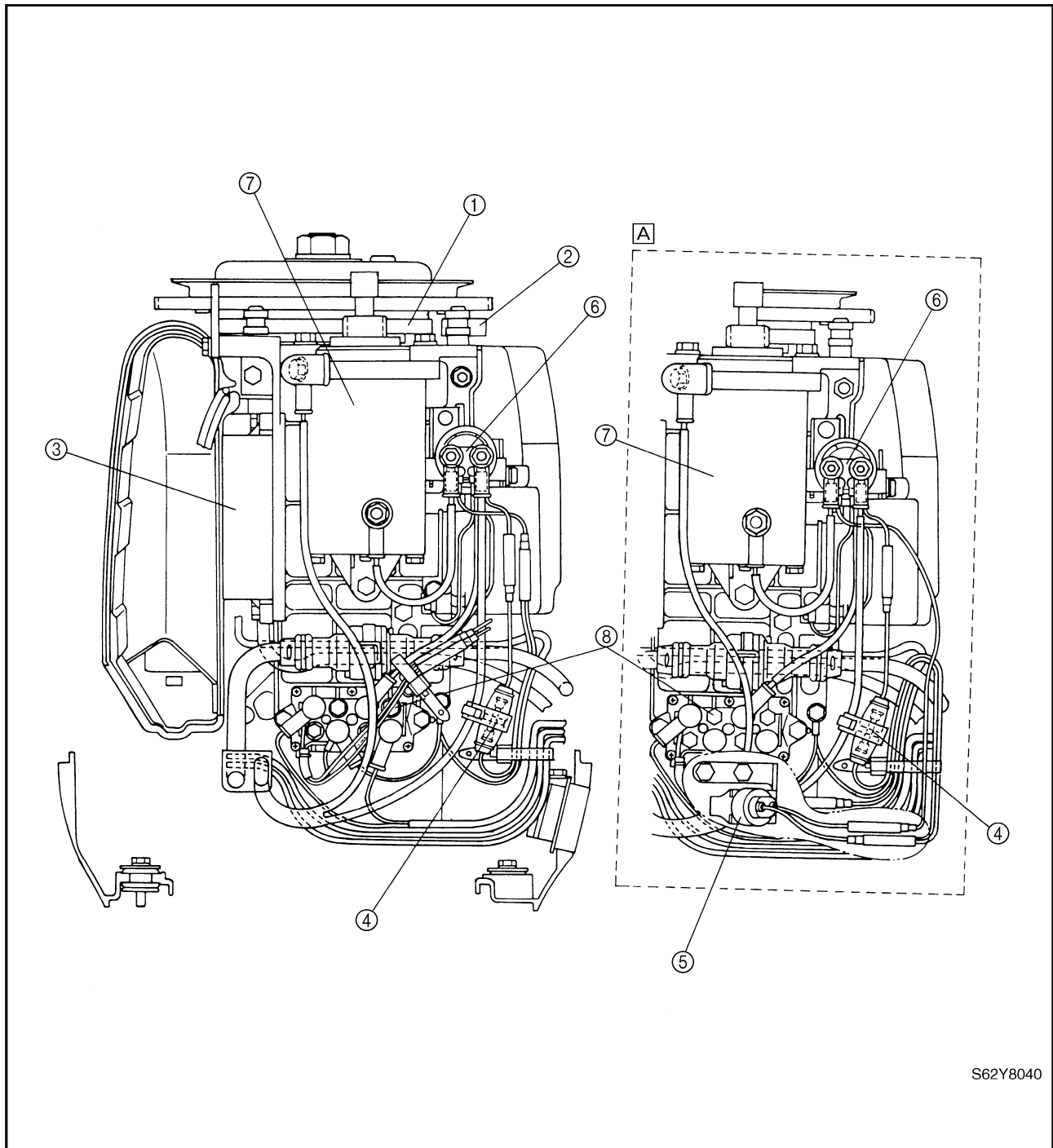

S62Y8040

- ① Stator
- ② Pulser coil
- ③ CDI unit
- ④ Fuse
- ⑤ Neutral switch (tiller handle model)
- ⑥ Starter relay
- ⑦ Starter motor
- ⑧ Power trim and tilt relay (power trim and tilt model)

▭ A Tiller handle model

Ignition system and Ignition control system

Digital multimeter: YU-34899-A
 Digital circuit tester: 90890-03174
 Peak voltage adaptor:
 YU-39991 / 90890-03172
 Test harness (2 pins):
 YB-06767 / 90890-06767

Charge coil output peak voltage:
 Brown (Br) – Blue (L)

r/min	Unloaded		Loaded	
	Cranking		1,500	3,500
DC V	144	137	169	129

Charge coil resistance (use as reference):
 Brown (Br) – Blue (L)
 272–408 Ω at 20 °C (68 °F)

Checking the pulser coil

1. Measure the pulser coil output peak voltage. Replace the pulser coil if below specification.

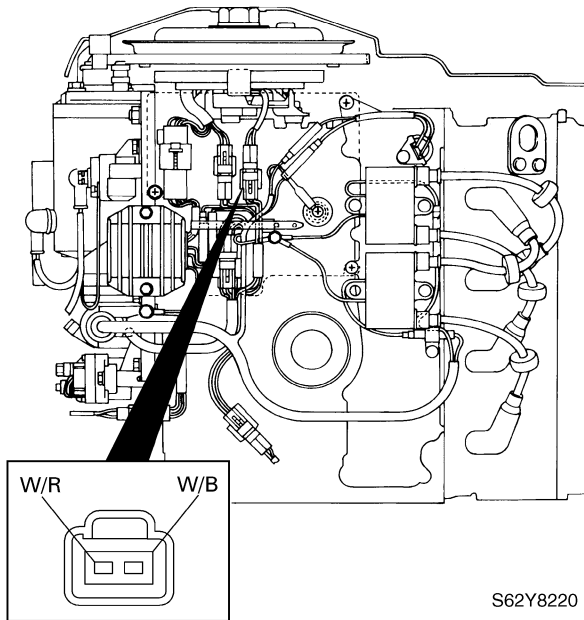

⚠ WARNING

When checking the peak voltage do not touch any of the connections of the digital tester leads.

NOTE:

- Use the peak voltage adaptor with the digital circuit tester.
- When measuring the peak voltage, set the selector on the digital circuit tester to the **DC voltage mode**.

Digital multimeter: YU-34899-A
 Digital circuit tester: 90890-03174
 Peak voltage adaptor:
 YU-39991 / 90890-03172
 Test harness (2 pins):
 YB-06767 / 90890-06767

Pulser coil output peak voltage:
 White/red (W/R) – White/black (W/B)

r/min	Unloaded		Loaded	
	Cranking		1,500	3,500
DC V	6.3	3.5	7.4	11.2

Pulser coil resistance (use as reference):
 White/red (W/R) – White/black (W/B)
 396–594 Ω at 20 °C (68 °F)

Checking the pulser coil air gap

1. Turn the flywheel magnet clockwise to align the projection of the flywheel magnet with the pulser coil projection.
2. Measure the gap between both projections with a thickness gauge. Adjust if out of specification.

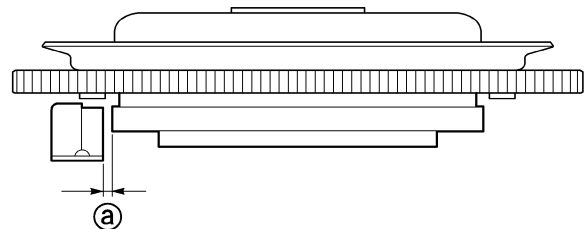

Pulser coil air gap $\text{\textcircled{a}}$:
 0.5–1.0 mm (0.020–0.039 in)

Checking the lighting coil

1. Measure the lighting coil output peak voltage. Replace the stator coil if below specification.

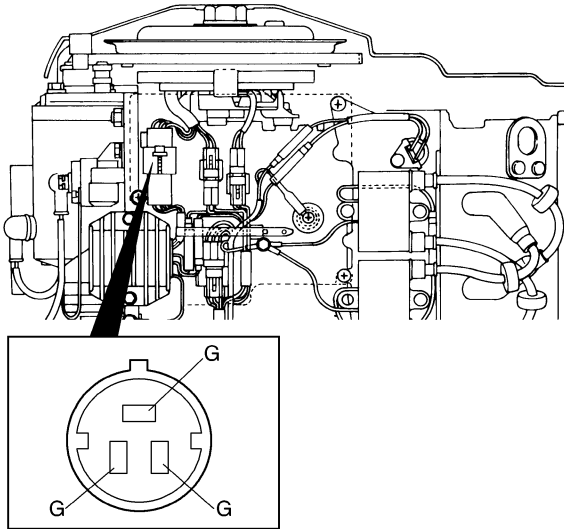

S62Y8470

⚠ WARNING

When checking the peak voltage do not touch any of the connections of the digital tester leads.

NOTE:

- Use the peak voltage adaptor with the digital circuit tester.
- When measuring the peak voltage, set the selector on the digital circuit tester to the **DC voltage mode**.

Digital multimeter: YU-34899-A
 Digital circuit tester: 90890-03174
 Peak voltage adaptor:
 YU-39991 / 90890-03172
 Test harness (3 pins):
 YB-06770 / 90890-06770

Lighting coil output peak voltage:
 Green (G) – Green (G)

r/min	Unloaded		
	Cranking	1,500	3,500
DC V	11.9	42	127

Lighting coil resistance (use as reference):
 Green (G) – Green (G)
 1.2–1.8 Ω at 20 °C (68 °F)

Checking the Rectifier Regulator

1. Measure the Rectifier Regulator output peak voltage. If below specification, measure the lighting coil output peak voltage. Replace the Rectifier Regulator if the output peak voltage of the lighting coil is above specification.

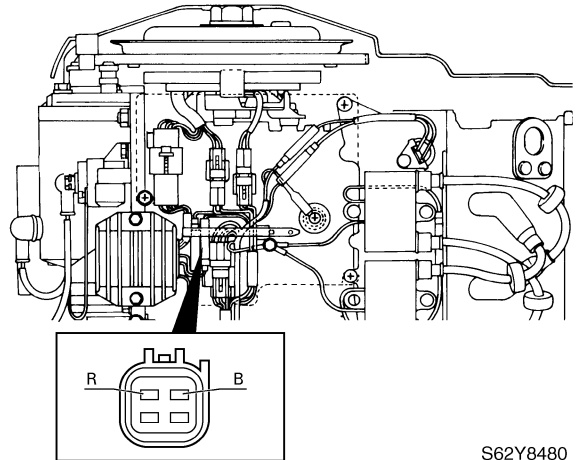

S62Y8480

⚠ WARNING

When checking the peak voltage do not touch any of the connections of the digital tester leads.

NOTE:

- Use the peak voltage adaptor with the digital circuit tester.
- When measuring the peak voltage, set the selector on the digital circuit tester to the **DC voltage mode**.

Digital multimeter: YU-34899-A
 Digital circuit tester: 90890-03174
 Peak voltage adaptor:
 YU-39991 / 90890-03172
 Test harness (4 pins):
 YB-06771 / 90890-06771

NOTICE

This Supplementary Service Manual has been prepared to introduce new service and new data information for the F60, T60 which is based on the F50, T50. For complete information on service procedures, it is necessary to use this Supplementary Service Manual together with the following manual.

F50C, T50C SERVICE MANUAL: 62Y-28197-1F-11 (LIT-18616-02-67)

Important information

Particularly important information is distinguished in this manual by the following notations:

 The Safety Alert Symbol means ATTENTION! BECOME ALERT! YOUR SAFETY IS INVOLVED!

WARNING

Failure to follow WARNING instructions could result in severe injury or death to the machine operator, a bystander, or a person inspecting or repairing the outboard motor.

CAUTION:

A CAUTION indicates special precautions that must be taken to avoid damage to the outboard motor.

NOTE:

A NOTE provides key information to make procedures easier or clearer.

**F60C, T60C
SUPPLEMENTARY SERVICE MANUAL
©2003 by Yamaha Motor Corporation, USA
1st Edition, September 2003
All rights reserved.
Any reprinting or unauthorized use
without the written permission of
Yamaha Motor Corporation, USA
is expressly prohibited.
Printed in USA
LIT-18616-02-68**

Identification / Propeller selection

Propeller selection

The performance of a boat and outboard motor will be critically affected by the size and type of propeller you choose. Propellers greatly affect boat speed, acceleration, engine life, fuel economy, and even boating and steering capabilities. An incorrect choice could adversely affect performance and could also seriously damage the engine.

Use the following information as a guide for selecting a propeller that meets the operating conditions of the boat and the outboard motor.

Propeller size

The size of the propeller is indicated on the propeller blade or outside of the propeller boss.

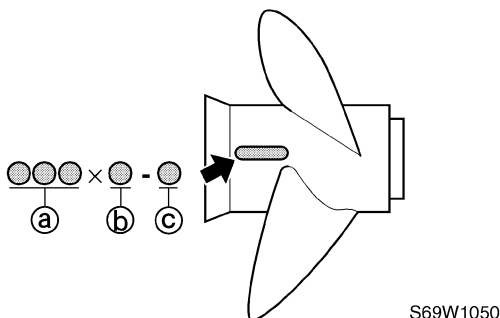
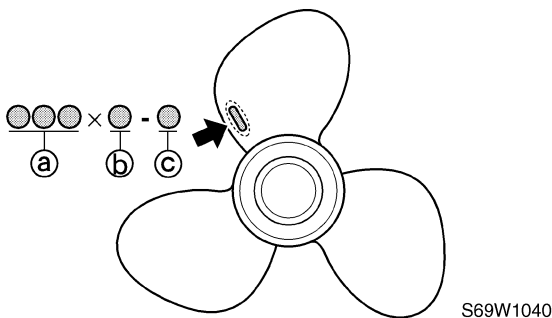
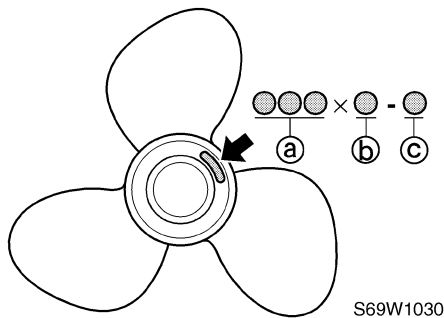

- Ⓐ Propeller diameter (in inches)
- Ⓑ Propeller pitch (in inches)
- Ⓒ Propeller type (propeller mark)

Selection

When the engine speed is at the full throttle operating range (5,000–6,000 r/min), the ideal propeller for the boat is one that provides maximum performance in relation to boat speed and fuel consumption.

F60

Propeller size (in)	Material
10 × 15 - G	Aluminum
10 3/8 × 13 - G	
10 5/8 × 12 - G	
10 3/4 × 16 - G	
11 × 15 - G	
11 5/8 × 11 - G	
11 3/4 × 10 - G	
12 1/4 × 9 - G	Stainless
10 1/4 × 14 - G	
10 1/4 × 15 - G	
10 1/4 × 16 - G	
10 5/8 × 13 - G	
11 1/2 × 13 - G	
11 3/4 × 12 - G	
12 × 11 - G	

T60

Propeller size (in)	Material
13 5/8 × 13 - K	Aluminum
14 × 11 - K	
14 × 11 - K (Dual thrust)	

Maintenance specifications

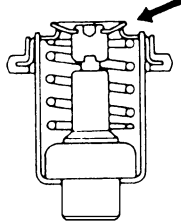
Item	Unit	Model	
		F60TR	T60TR
Crankcase main journal bearing thickness			
Yellow	mm (in)	1.502–1.506 (0.0591–0.0593)	
Red	mm (in)	1.498–1.502 (0.0590–0.0591)	
Pink	mm (in)	1.494–1.498 (0.0588–0.0590)	
Green	mm (in)	1.490–1.494 (0.0587–0.0588)	
Oil pump			
Type		Trochoid	
Outer rotor-to-housing clearance	mm (in)	0.09–0.15 (0.0035–0.0059)	
Outer rotor-to-inner rotor clearance limit	mm (in)	0.01–0.10 (0.0004–0.0039)	
Rotor-to-cover clearance	mm (in)	0.03–0.08 (0.0012–0.0031)	
Thermostat			
Opening temperature	°C (°F)	60 (140)	
Fully open temperature	°C (°F)	70 (158)	
			
Valve open lower limit	mm (in)	3.0 (0.12)	
Fuel pump			
Discharge	L (US gal, Imp gal)/hr at 6,000 r/min	70 (18.5, 15.4)	
Pressure	kPa (kgf/cm ² , psi)	49 (0.49, 7.0)	
Plunger stroke	mm (in)	5.85–9.65 (0.2303–0.3799)	
Carburetor			
ID mark		69W12	
Main jet	#	124	
Pilot jet	#	39	
Float height	mm (in)	5.2 (0.20)	
Engine idle speed	r/min	850 ± 50	

Special service tools

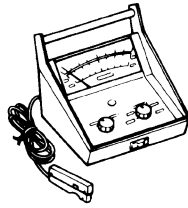

Inductive self-powered tachometer
YU-08036-B

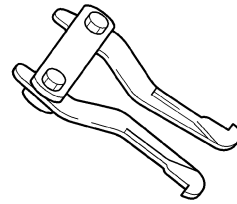

Puller claw
YB-06523

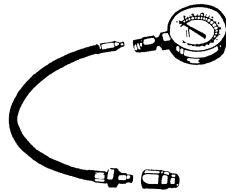

Compression gauge
YU-33223-1

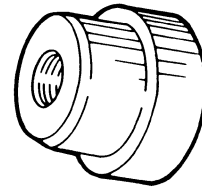

Bearing housing needle bearing remover
YB-06112, YB-06153

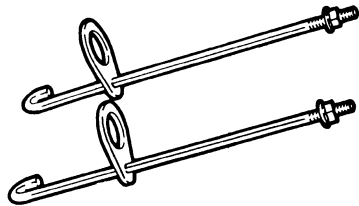

Bearing housing puller
YB-06207

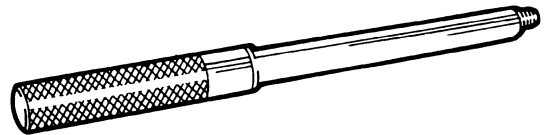

Driver handle
YB-06071

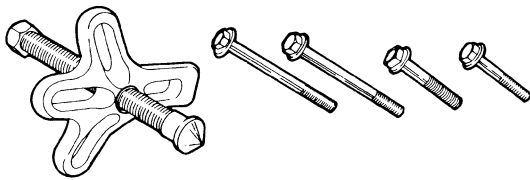

Universal puller
YB-06117

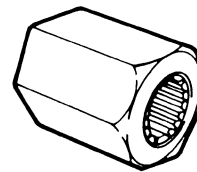

Drive shaft holder
YB-06049

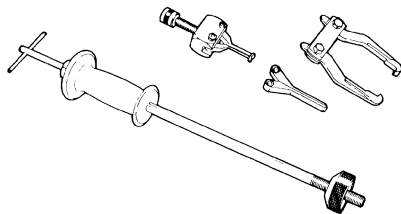

Slide hammer and adapters
YB-06096

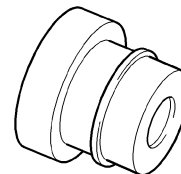

Drive shaft needle bearing remover and installer
YB-06063, YB-06155

3

Fuel line and fuel filter

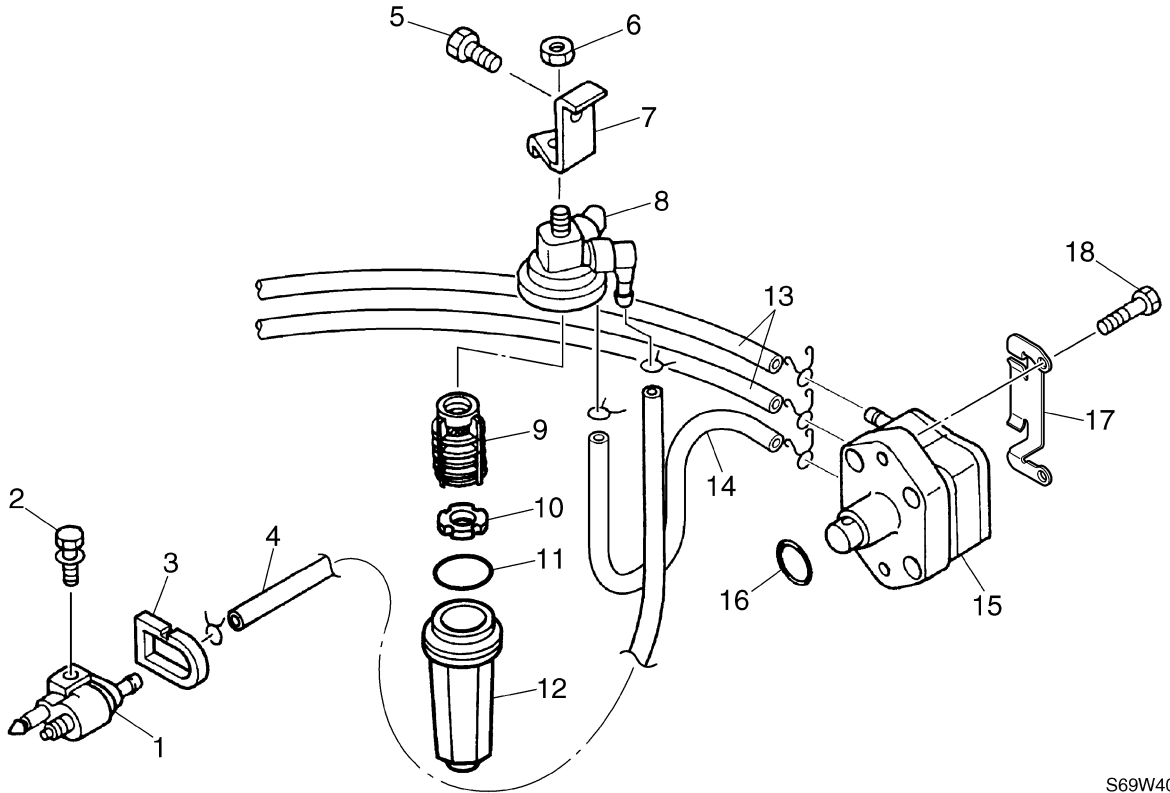

S69W4030

No.	Part name	Q'ty	Remarks
1	Fuel joint	1	
2	Bolt	1	M6 × 25 mm
3	Seal	1	
4	Fuel hose	1	Fuel joint-to-fuel filter
5	Bolt	1	M8 × 14 mm
6	Nut	1	
7	Bracket	1	
8	Body	1	
9	Fuel filter element	1	
10	Float	1	
11	O-ring	1	Not reusable
12	Cup	1	
13	Fuel hose	2	Fuel pump-to-carburetor
14	Fuel hose	1	Fuel filter-to-fuel pump
15	Fuel pump	1	
16	O-ring	1	Not reusable
17	Bracket	1	
18	Bolt	2	M6 × 30 mm

No.	Part name	Q'ty	Remarks
1	Rocker arm assembly	8	
2	Rocker arm shaft	1	
3	Cylinder head	1	
4	Exhaust valve	4	
5	Intake valve	4	
6	Camshaft	1	
7	Valve cotter	16	
8	Spring retainer	8	
9	Valve spring	8	
10	Spring seat	8	
11	Stem seal	8	Not reusable
12	Valve guide	8	Not reusable
13	Retaining bolt	1	
14	Gasket	1	Not reusable
15	Oil seal	1	Not reusable
16	Bolt	5	M8 × 22 mm
17	Rocker arm retainer	2	
18	Tensioner	2	
19	Rocker arm retainer	1	
20	Stopper guide	2	

4. Calculate the forward gear shim(s) (T1).

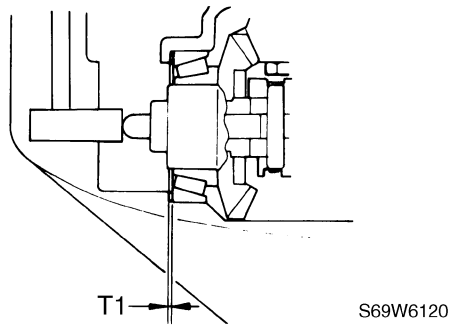

NOTE:

The sum of T1 and M should not be more than M0.

Calculation formula:

$$\text{Forward gear shim thickness (T1)} = M0 - M$$

5. Select the forward gear shim(s) (T1) as follows.

Calculated numeral at 1/100 place	Rounded numeral
1, 2	0
3, 4, 5	2
6, 7, 8	5
9, 10	8

Available shim thicknesses:

0.10, 0.12, 0.15, 0.18, 0.30, 0.40, and 0.50 mm

Example:

If "T1" is 0.45 mm, then the forward gear shim is 0.42 mm.

If "T1" is 0.60 mm, then the forward gear shim is 0.58 mm.

Propeller shaft housing (T60)

4. Install the reverse gear assembly into the propeller shaft housing using a press.

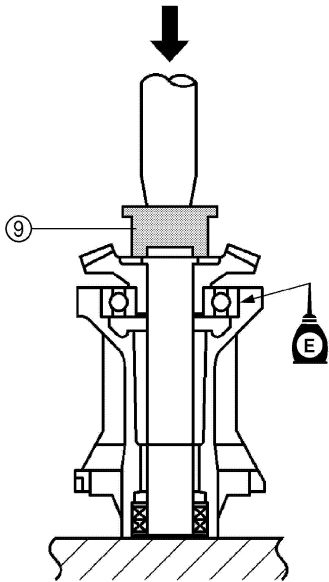

S68S6120



Forward gear bearing cup
installer ⑨:
YB-06109

Drive shaft and lower case (T60)

4. Install the trim tab ② to its original position, and then connect the speedometer hose ③.

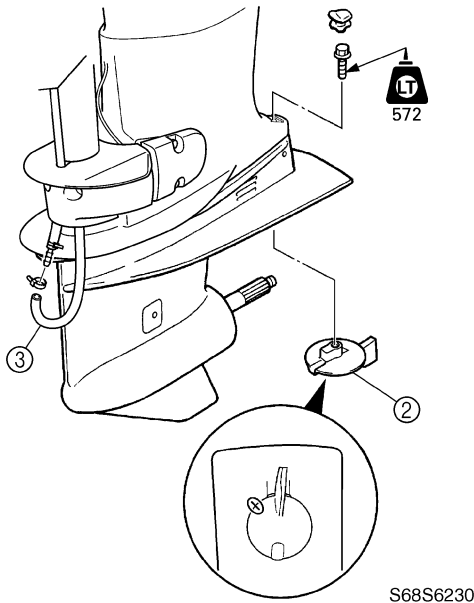

5. Install the propeller and propeller nut, and then tighten the nut finger tight. Place a block of wood between the anti-cavitation plate and propeller to keep the propeller from turning, and then tighten the nut to the specified torque.

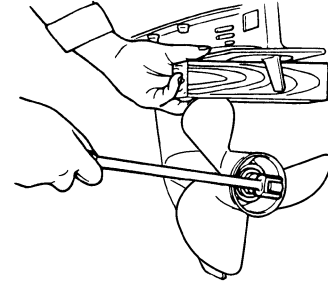
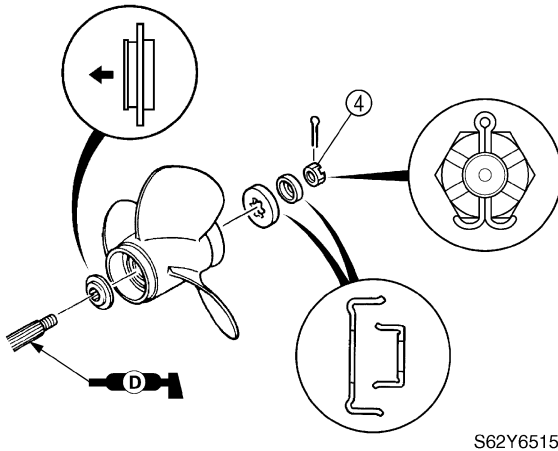

S69J6340

⚠ WARNING

- Do not hold the propeller with your hands when loosening or tightening it.
- Be sure to disconnect the battery leads from the battery and the clip from the engine stop lanyard switch.
- Put a block of wood between the anti-cavitation plate and propeller to keep the propeller from turning.

NOTE:

If the grooves in the propeller nut ④ do not align with the cotter pin hole, tighten the nut until they are aligned.



Propeller nut ④:
35 N·m (3.5 kgf·m, 25 ft·lb)

Upper case

No.	Part name	Q'ty	Remarks
1	Muffler assembly	1	
2	Upper case	1	
3	Muffler seal	1	
4	Rubber seal	1	
5	Dowel pin	2	
6	Grommet	1	
7	Damper	1	
8	Screw	2	ø5 × 16 mm
9	Baffle plate	1	
10	Bolt	4	M8 × 30 mm
11	Drive shaft bushing	1	
12	Circlip	1	
13	Ground lead	1	
14	Screw	1	ø6 × 8 mm
15	Cap	2	
16	Bolt	2	M12 × 170 mm
17	Washer	2	
18	Rubber washer	2	
19	Washer	2	
20	Lower mount	2	
21	Washer	2	
22	Mount cover	2	
23	Bolt	4	M8 × 30 mm
24	Bolt	2	M8 × 175 mm
25	Plate	1	
26	Bolt	3	M8 × 30 mm
27	Upper mount	1	
28	Nut	2	
29	Grease nipple	1	
30	Washer	2	
31	Nut	2	
32	Cover	1	
33	Bolt	2	M8 × 20 mm

Power trim and tilt unit (F60)

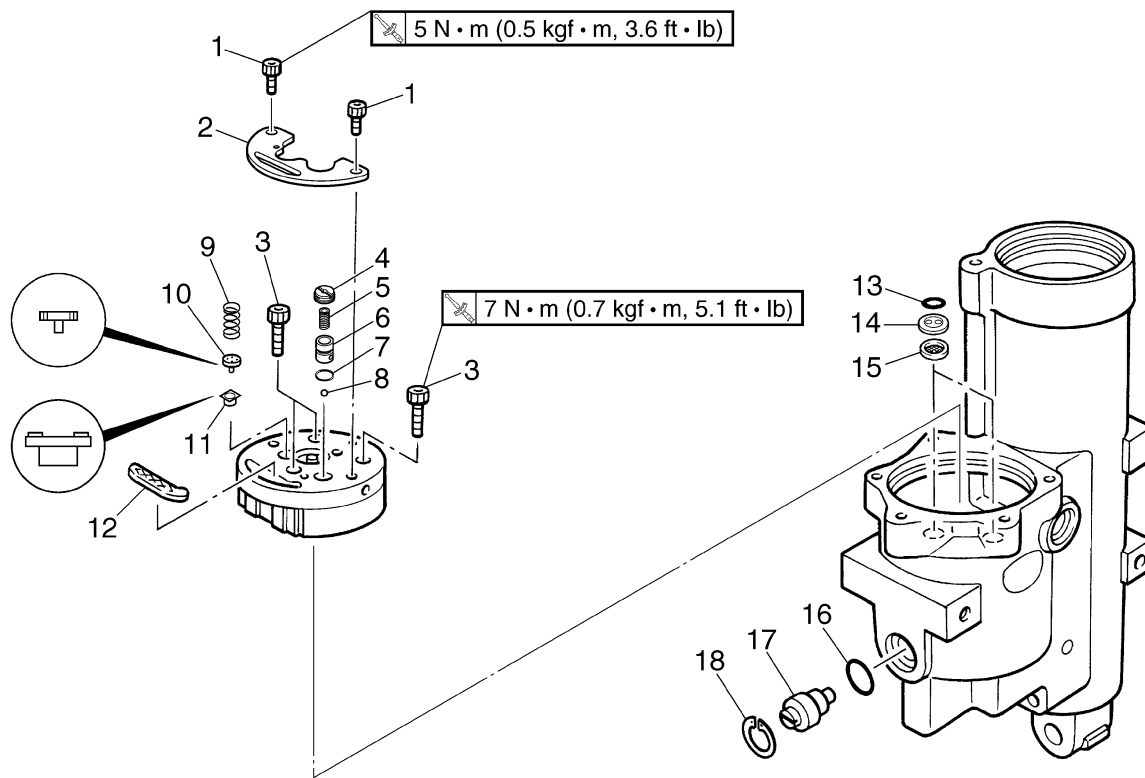

S69W7190

No.	Part name	Q'ty	Remarks
1	Bolt	2	M5 × 8 mm
2	Relief valve bracket	1	
3	Bolt	3	M6 × 40 mm
4	Valve lock screw	1	
5	Up-relief spring	1	
6	Valve support pin	1	
7	O-ring	1	Not reusable
8	Ball	1	
9	Down-relief spring	1	
10	Valve support pin	1	
11	Relief valve seal	1	
12	Filter	1	
13	O-ring	2	Not reusable
14	Spacer	2	
15	Filter	2	
16	O-ring	1	Not reusable
17	Manual valve	1	
18	Circlip	1	

Power trim and tilt unit (T60)

Disassembling the tilt cylinder

1. Hold the power trim and tilt unit ① in a vise using aluminum plates ② on both sides.

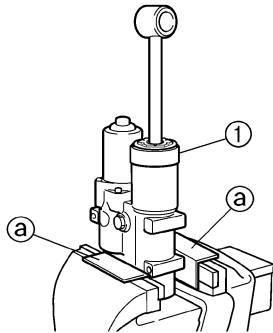

S68S7030

2. Loosen the tilt cylinder end screw ②, and then remove it.

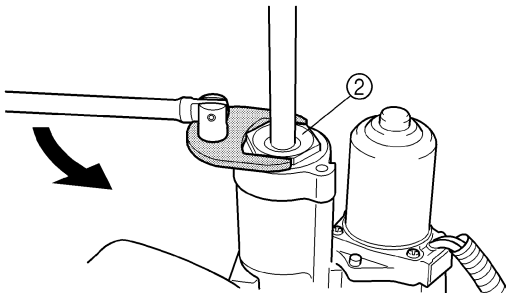

S68S7040

⚠ WARNING

Make sure that the ram is fully extended before removing the end screw.



Cylinder-end screw wrench:
YB-06588

3. Drain the power trim and tilt fluid.

Assembling the tilt cylinder

1. Install the free piston ① into the trim cylinder ② with the circlip ③.

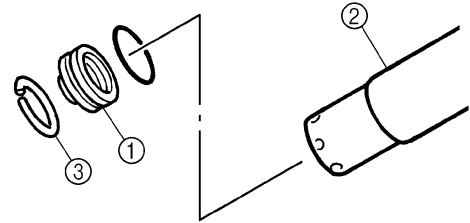

S68S7050

2. Install the trim cylinder base ④, springs ⑤, and plate ⑥ into the trim cylinder with the circlip ⑦.

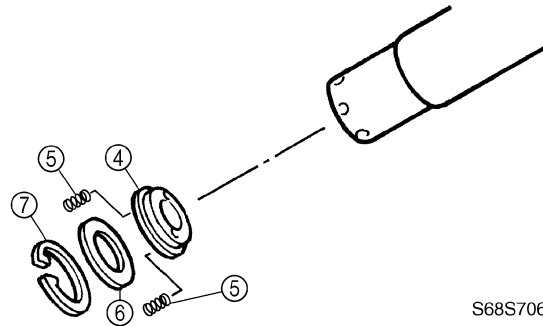

S68S7060

3. Hold the power trim and tilt unit ⑧ in a vise using aluminum plates ② on both sides.

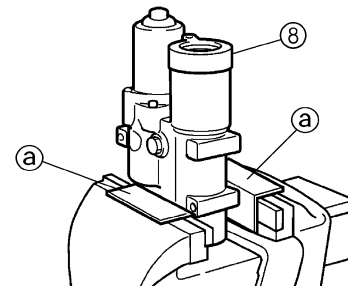

S68S7070

CLICK HERE TO **DOWNLOAD** THE COMPLETE MANUAL

- Thank you very much for reading the preview of the manual.
- You can download the complete manual from: www.heydownloads.com by clicking the link below



- Please note: If there is no response to CLICKING the link, please download this PDF first and then click on it.

CLICK HERE TO **DOWNLOAD** THE COMPLETE MANUAL