



READ THIS MANUAL CAREFULLY!
It contains important safety information.

OWNER'S MANUAL

BADGER

YFM80N(C)

▲WARNING

This ATV should not be ridden by anyone under 12 years of age.

LIT-11626-14-04

4EM-28199-1B

CLICK HERE TO **DOWNLOAD** THE COMPLETE MANUAL

- Thank you very much for reading the preview of the manual.
- You can download the complete manual from: www.heydownloads.com by clicking the link below



- Please note: If there is no response to CLICKING the link, please download this PDF first and then click on it.

CLICK HERE TO **DOWNLOAD** THE COMPLETE MANUAL

④

⚠ WARNING

IMPROPER TIRE PRESSURE OR OVERLOADING CAN CAUSE LOSS OF CONTROL.

LOSS OF CONTROL CAN RESULT IN SEVERE INJURY OR DEATH.

OPERATING TIRE PRESSURE : Set with tires cold

- Recommended : FRONT : 20 kPa, {0.20 kgf/cm²}, 2.9 psi
REAR : 20 kPa, {0.20 kgf/cm²}, 2.9 psi
- Minimum : FRONT : 17 kPa, {0.17 kgf/cm²}, 2.5 psi
REAR : 17 kPa, {0.17 kgf/cm²}, 2.5 psi

- Never set tire pressure below minimum.
It could cause the tire to dislodge from the rim.

LOADING

- Maximum Vehicle Load : 95 kg, (209 lbs).
Includes weight of operator, cargo and accessories.

4EM-21696-11

⑤

⚠ WARNING



NEVER ride as a passenger.

Passengers can cause a loss of control, resulting in SEVERE INJURY or DEATH.

5FE-2151H-01

Vehicle identification number

The vehicle identification number is stamped into the frame.

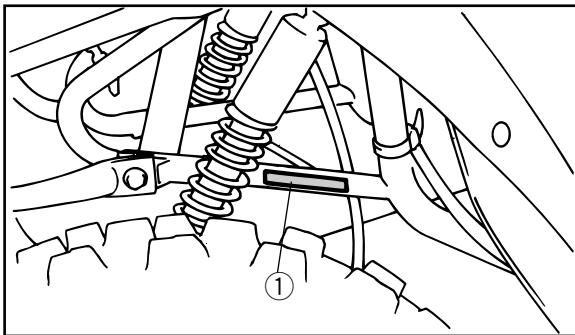

1. Vehicle identification number

NOTE: _____

The vehicle identification number is used to identify your machine.

Model label

The model label is affixed to the frame. Record the information on this label in the space provided. This information will be needed to order spare parts from your Yamaha dealer.

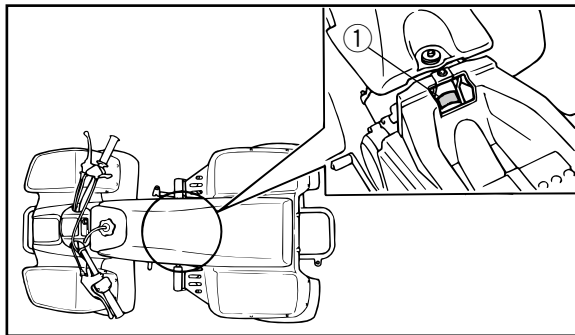

1. Model label

Seat

To remove the seat, pull the seat lock lever upward and pull up the seat at the rear.

To install the seat, insert the projection on the front of the seat into the seat holder and push down on the seat at the rear.

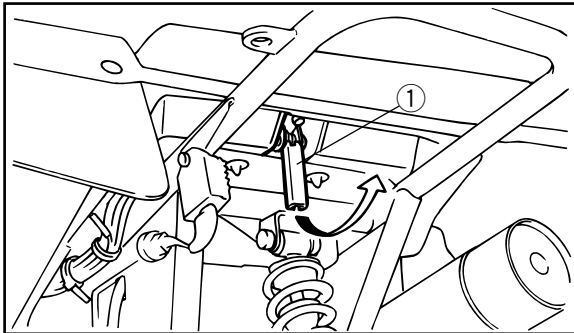

1. Seat lock lever

NOTE: _____

Make sure that the seat is securely fitted.

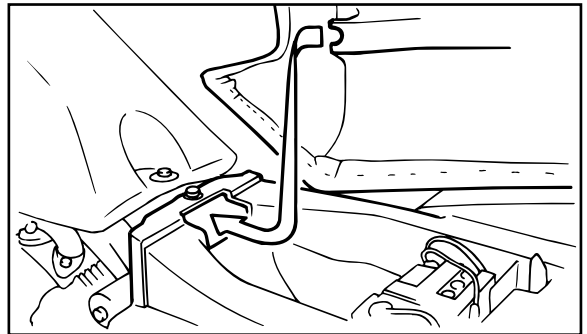

Tire wear limit

When the tire groove decreases to 3 mm (0.12 in) due to wear, replace the tire.

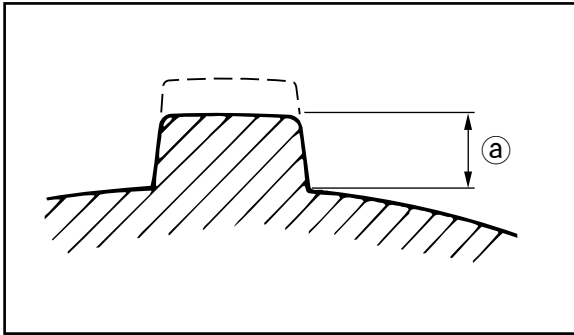

a. 3 mm (0.12 in)

Loading

As originally equipped, this ATV is not designed to carry cargo or tow a trailer. If you choose to add accessories so that you can carry cargo or tow a trailer, you must use common sense and good judgment. Keep the following points in mind:

- Never exceed the weight limits shown. An overloaded ATV can be unstable.

MAXIMUM LOADING LIMIT

Vehicle loading limit (total weight of cargo, rider and accessories):
95 kg (209 lb)

- Load cargo on the carriers as close to the center of the vehicle as possible. Put cargo at the rear of the front carrier and at the front of the rear carrier. Center the load from side to side.

- Tie down cargo securely to the carriers. Make sure cargo in the trailer cannot move around. A shifting load can cause an accident.
- Make sure the load does not interfere with controls or your ability to see where you are going.
- Ride more slowly than you would without a load. The more weight you carry, the slower you should go. Although conditions vary, it is good practice not to exceed 2nd gear whenever you are carrying heavier loads or when towing a trailer.
- Allow more braking distance. A heavier vehicle takes longer to stop.
- Avoid making sharp turns unless at very slow speeds.
- Avoid hills and rough terrain. Choose terrain carefully. Added weight affects the stability and handling of the ATV.

Do not operate after consuming alcohol or drugs.

Operator's performance capability is reduced by the influence of alcohol or drugs.



⚠ WARNING

POTENTIAL HAZARD

Operating this ATV after consuming alcohol or drugs.

WHAT CAN HAPPEN

**Could seriously affect your judgment.
Could cause you to react more slowly.
Could affect your balance and perception.
Could result in an accident.**

HOW TO AVOID THE HAZARD

Never consume alcohol or drugs before or while driving this ATV.

Know the terrain where you ride. Ride cautiously in unfamiliar areas.

Stay alert for **holes, rocks, or roots** in the terrain, and **other hidden hazards** which may cause the machine to upset.

⚠ WARNING

POTENTIAL HAZARD

Failure to use extra care when operating this ATV on unfamiliar terrain.

WHAT CAN HAPPEN

You can come upon hidden rocks, bumps, or holes, without enough time to react. Could result in the ATV overturning or going out of control.

HOW TO AVOID THE HAZARD

Go slowly and be extra careful when operating on unfamiliar terrain. Always be alert to changing terrain conditions when operating the ATV.

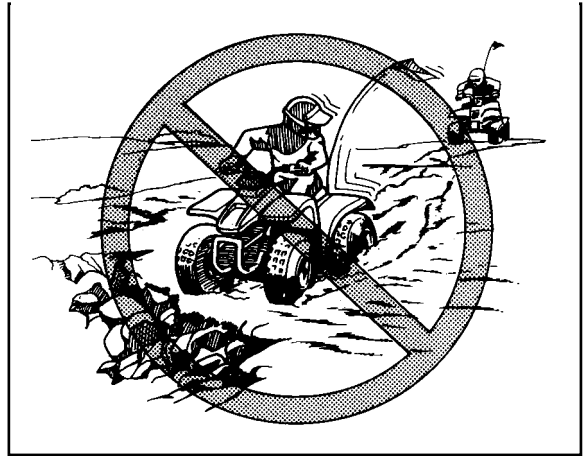

If your ATV has stalled or stopped and you believe you can continue up the hill, restart carefully to make sure you do not lift the front wheels which could cause you to lose control. If you are unable to continue up the hill, dismount the ATV on the uphill side. Physically turn the ATV around and then descend the hill.

If you start to roll backwards, DO NOT use the rear brake to stop or try to put the ATV in gear. The ATV could easily tip over backwards. Instead, dismount the ATV immediately on the uphill side.

WARNING

POTENTIAL HAZARD

Stalling, rolling backwards or improperly dismounting while climbing a hill.

WHAT CAN HAPPEN

Could result in the ATV overturning.

HOW TO AVOID THE HAZARD

Use proper gear and maintain steady speed when climbing a hill.

If you lose all forward speed:

Keep weight uphill.

Apply the brakes.

Lock parking brake, after you are stopped.

If you begin rolling backwards:

Keep weight uphill.

Never apply the rear brake while rolling backwards.

Apply the front brake.

SLIDING AND SKIDDING

Care should be used when riding on loose or slippery surfaces since the ATV may slide. If unexpected and uncorrected, sliding could lead to an accident.

To reduce the tendency for the front wheels to slide in loose or slippery conditions, positioning your weight over the front wheels will sometimes help.

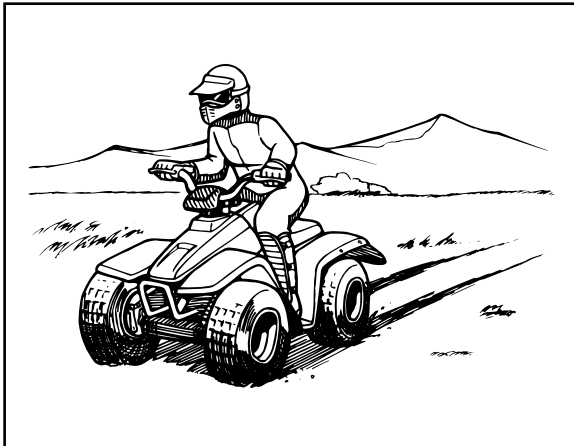

If the rear wheels of your ATV start to slide sideways, control can usually be regained (if there is room to do so) by steering in the direction of the slide. Applying the brakes or accelerating is not recommended until you have corrected the slide.

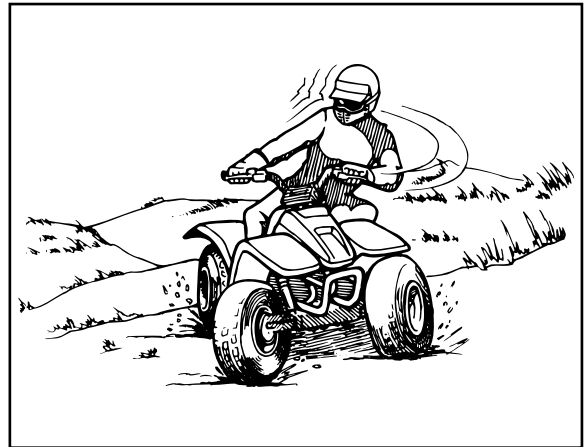

Final gear oil

1. Final gear oil measurement
 - a. Place the machine on a level place.
 - b. Remove the dipstick and wipe it off with a clean rag. Insert the dipstick in the filler hole without screwing it in.
 - c. Remove the dipstick and inspect the oil level.
 - d. The oil level should be between the maximum and minimum marks. If the level is low, add oil to raise it to the proper level.

CAUTION: _____

Be sure no foreign material enters the final gear case.

- e. Install the dipstick.

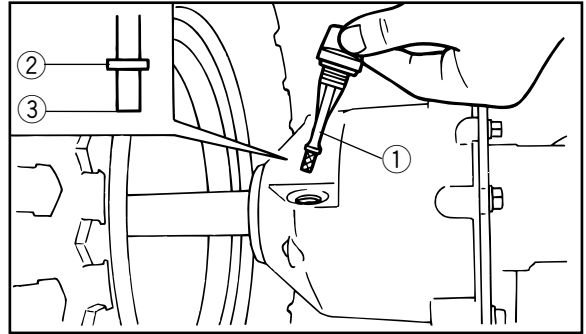

1. Dipstick
2. Maximum level mark
3. Minimum level mark

2. Final gear oil replacement
 - a. Place the machine on a level place.
 - b. Place a container under the final gear case.
 - c. Remove the dipstick and drain bolt to drain the oil.

Front brake lever free play adjustment

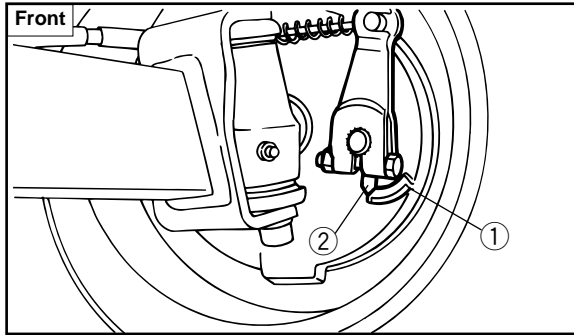

1. Wear limit

2. Wear indicator

NOTE: _____
 Before adjusting the brake, inspect the front brake shoes.

The front brake lever free play should be adjusted to 10 ~ 12 mm (0.4 ~ 0.5 in) at the brake lever pivot. If the free play is incorrect, adjust as follows:

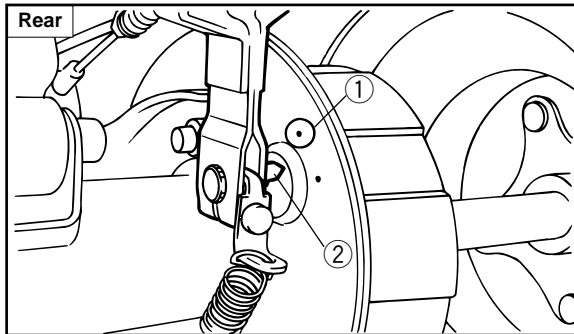

1. Wear limit

2. Wear indicator

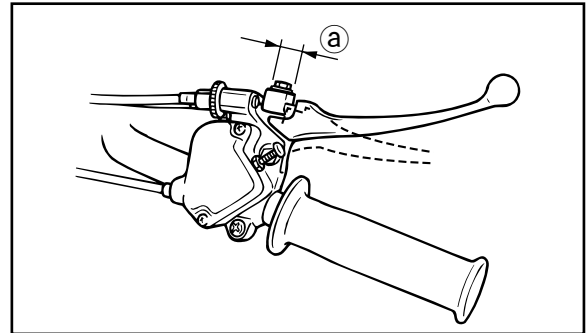

a. Free play 10 ~ 12 mm (0.4 ~ 0.5 in)

Replenishing the battery fluid

A poorly maintained battery will corrode and discharge quickly. The battery fluid should be checked at least once a month.

1. The level should be between the upper and lower level marks. Use only distilled water if refilling is necessary.

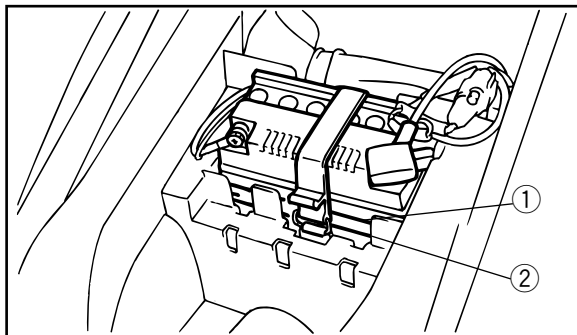

1. Maximum level mark
 2. Minimum level mark
2. Disconnect the negative (-) lead.
 3. Disconnect the positive (+) lead and remove the battery.

CAUTION:

Normal tap water contains minerals which are harmful to a battery. Therefore, refill only with distilled water.

4. When the machine is not to be used for a month or longer, remove the battery and store it in a cool, dark place. Completely recharge the battery before reusing.
5. If the battery is to be stored for a longer period than the above, check the specific gravity at least once a month and recharge the battery when it is too low.
6. Always make sure the connections are correct when putting the battery back in the machine. Make sure the breather hose is properly connected and is not damaged or obstructed.

Model	YFM80
Transmission: Primary reduction system Primary reduction ratio Secondary reduction system Secondary reduction ratio Transmission type Operation Gear ratio: 1st 2nd 3rd	Spur gear 65/20 (3.250) Shaft drive 19/18 × 34/10 (3.588) Constant mesh 3-speed Left foot operation 39/11 (3.545) 35/17 (2.059) 31/22 (1.409)
Chassis: Frame type Caster angle Trail	Steel tube 1° 3.8 mm (0.15 in)
Tire: Type Size : Front Size : Rear	Tubeless AT18 × 7-7 AT18 × 8-7

WARNING

Improper ATV use can result in SEVERE INJURY or DEATH.



**ALWAYS USE
AN APPROVED
HELMET AND
PROTECTIVE GEAR**



**NEVER USE
ON PUBLIC
ROADS**



**NEVER CARRY
PASSENGERS**



**NEVER USE
WITH DRUGS
OR ALCOHOL**

NEVER operate:

- without proper training or instruction.
- at speeds too fast for your skills or the conditions.
- on public roads - a collision can occur with another vehicle.
- with a passenger - passengers affect balance and steering and increase risk of losing control.

ALWAYS:

- use proper riding techniques to avoid vehicle overturns on hills and rough terrain and in turns.
- avoid paved surfaces - pavement may seriously affect handling and control.

LOCATE AND READ OWNER'S MANUAL. FOLLOW ALL INSTRUCTIONS AND WARNINGS.
(For replacement manual, call 1-800-532-1558)



YAMAHA























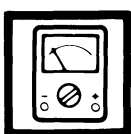

YAMAHA MOTOR CO., LTD.

MAINTENANCE SPECIFICATIONS

SPEC



Model	YFM80M/YFM80MC																			
Direction of winding (top view)	IN EX	Clockwise Clockwise 																		
Piston: Piston to cylinder clearance <Limit> Piston size "D"	0.025 ~ 0.045 mm (0.0010 ~ 0.0018 in) <0.15 mm (0.0059 in)> 46.96 ~ 46.98 mm (1.849 ~ 1.850 in)																			
Measuring point "H" Oversize Oversize Piston off-set Piston off-set direction Piston pin bore inside diameter Piston pin outside diameter	2nd 4th	6.5 mm (0.256 in) 47.5 mm (1.870 in) 48 mm (1.890 in) 0.75 mm (0.03 in) Inside 13.002 ~ 13.013 mm (0.5119 ~ 0.5123 in) 12.996 ~ 13.000 mm (0.5117 ~ 0.5118 in)																		
Clutch: Friction plate thickness Quantity Friction plate wear limit Clutch plate thickness Quantity Warp limit Clutch spring free length Quantity Clutch release method	2.92 ~ 3.08 mm (0.115 ~ 0.121 in) 6 2.9 mm (0.11 in) 1.2 ~ 1.6 mm (0.047 ~ 0.063 in) 5 0.06 mm (0.002 in) 28.3 mm (1.11 in) 8 Inner push, cam push																			
Carburetor: I. D. mark Main jet Main air jet Jet needle Needle jet Pilot outlet Pilot jet Valve seat size	(M.J.) (M.A.J.) (J.N.) (N.J.) (P.O.) (P.J.) (V.S.)	<table border="1" style="width: 100%; border-collapse: collapse;"> <thead> <tr> <th style="width: 50%; text-align: center;">4EMT</th> <th style="width: 50%; text-align: center;">4EMS</th> </tr> </thead> <tbody> <tr> <td style="text-align: center;">3GB 00</td> <td style="text-align: center;">4EMS 00</td> </tr> <tr> <td style="text-align: center;">#80</td> <td style="text-align: center;">#76.3</td> </tr> <tr> <td style="text-align: center;">ø1.2</td> <td style="text-align: center;">←</td> </tr> <tr> <td style="text-align: center;">3PZ5-3</td> <td style="text-align: center;">←</td> </tr> <tr> <td style="text-align: center;">D-8 (#559)</td> <td style="text-align: center;">←</td> </tr> <tr> <td style="text-align: center;">0.7</td> <td style="text-align: center;">←</td> </tr> <tr> <td style="text-align: center;">#12.5</td> <td style="text-align: center;">←</td> </tr> <tr> <td style="text-align: center;">1.2</td> <td style="text-align: center;">←</td> </tr> </tbody> </table>	4EMT	4EMS	3GB 00	4EMS 00	#80	#76.3	ø1.2	←	3PZ5-3	←	D-8 (#559)	←	0.7	←	#12.5	←	1.2	←
4EMT	4EMS																			
3GB 00	4EMS 00																			
#80	#76.3																			
ø1.2	←																			
3PZ5-3	←																			
D-8 (#559)	←																			
0.7	←																			
#12.5	←																			
1.2	←																			

① GEN INFO 	② SPEC 	
③ INSP ADJ 	④ ENG 	
⑤ COOL 	⑥ CARB 	
⑦ DRIV 	⑧ CHAS 	
⑨ ELEC 	⑩ TRBL SHTG ? 	
⑪ 	⑫ 	
⑬ 	⑭ 	
⑮ 	⑯ 	
⑰ 	⑱ 	
⑲ 	⑳ 	㉑ 
㉒ 	㉓ 	㉔ 

ILLUSTRATED SYMBOLS (Refer to the illustration)

Illustrated symbols ① to ⑩ are designed as thumb tabs to indicate the chapter's number and content.

- ① General information
- ② Specifications
- ③ Periodic inspection and adjustment
- ④ Engine
- ⑤ Cooling system
- ⑥ Carburetion
- ⑦ Drive train
- ⑧ Chassis
- ⑨ Electrical
- ⑩ Troubleshooting

Illustrated symbols ⑪ to ⑰ are used to identify the specifications appearing in the text.

- ⑪ Filling fluid
- ⑫ Lubricant
- ⑬ Special tool
- ⑭ Tightening
- ⑮ Wear limit, clearance
- ⑯ Engine speed
- ⑰ Ω , V, A

Illustrated symbols ⑱ to ㉔ in the exploded diagram indicate grade of lubricant and location of lubrication point.

- ⑱ Apply locking agent (Loctite®)
- ⑲ Apply engine oil
- ⑳ Apply gear oil
- ㉑ Apply molybdenum disulfide oil
- ㉒ Apply wheel bearing grease
- ㉓ Apply lightweight lithium-soap base grease
- ㉔ Apply molybdenum disulfide grease

CLICK HERE TO **DOWNLOAD** THE COMPLETE MANUAL

- Thank you very much for reading the preview of the manual.
- You can download the complete manual from: www.heydownloads.com by clicking the link below



- Please note: If there is no response to CLICKING the link, please download this PDF first and then click on it.

CLICK HERE TO **DOWNLOAD** THE COMPLETE MANUAL

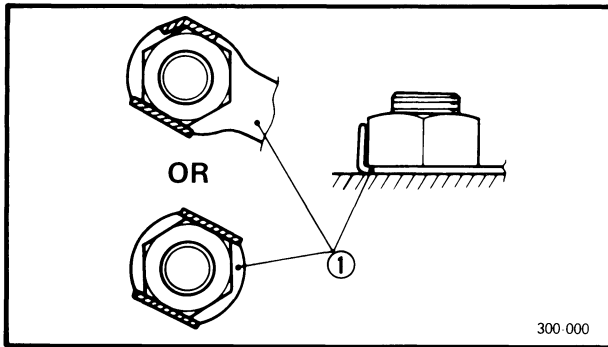

LOCK WASHERS/PLATES AND COTTER PINS

1. All lock washers/plates ① and cotter pins must be replaced when they are removed. Lock tab(s) should be bent along the bolt or nut flat(s) after the bolt or nut has been properly tightened.

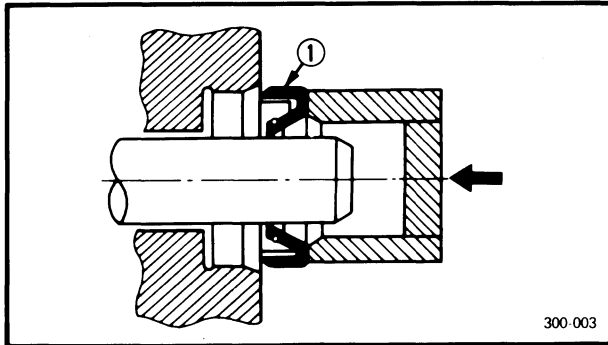

BEARINGS AND OIL SEALS

1. Install the bearing(s) and oil seal(s) with their manufacturer's marks or numbers facing outward. (In other words, the stamped letters must be on the side exposed to view.) When installing oil seal(s), apply a light coating of light-weight lithium base grease to the seal lip(s). Oil the bearings liberally when installing.

① Oil seal

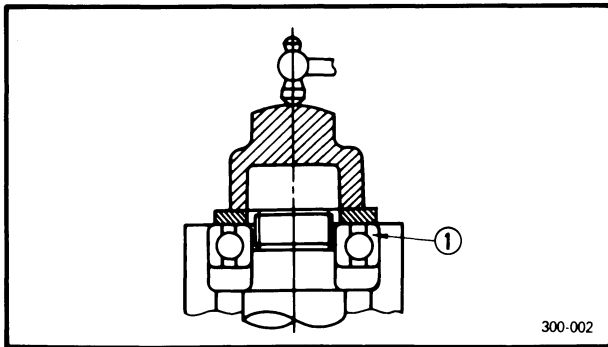

CAUTION:

Do not use compressed air to spin the bearings dry. This causes damage to the bearing surfaces.

① Bearing

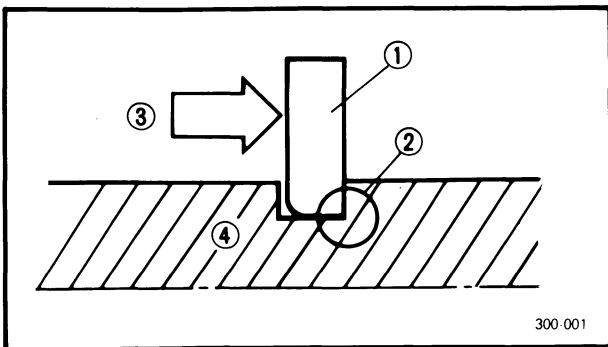

CIRCLIPS

1. All circlips should be inspected carefully before reassembly. Always replace piston pin clips after one use. Replace distorted circlips. When installing a circlip ①, make sure that the sharp edged corner ② is positioned opposite to the thrust ③ it receives. See the sectional view.

④ Shaft

MAINTENANCE SPECIFICATIONS



Model	YFM80(D)
Clutch: Friction plate: Thickness × Quantity <Wear limit> Clutch plate: Thickness × Quantity <Warp limit> Clutch spring: Free length × Quantity Clutch release method Clutch-in revolution Clutch-stall revolution	2.92 ~ 3.08 mm (0.115 ~ 0.121 in) × 6 <2.9 mm (0.114 in)> 1.2 ~ 1.6 mm (0.047 ~ 0.063 in) × 5 <0.06 mm (0.0024 in)> 30.1 mm (1.185 in) × 8 Inner push, cam push 2,100 ~ 2,300 r/min 2,800 ~ 3,000 r/min
Transmission: <Main axle deflection limit> <Drive axle deflection limit>	<0.08 mm (0.0031 in)> <0.08 mm (0.0031 in)>
Shifter: Shifter type	Cam drum and guide bar
Carburetor: Type/manufacturer/quantity I.D. mark Main jet (M.J.) Main air jet (M.A.J.) Jet needle-clip position (J.N.) Needle jet (N.J.) Cutaway (C.A.) Pilot jet (P.J.) Pilot outlet (P.O.) Pilot screw (P.S.) Valve seat (V.S.) Fuel level (F.L.) Float height (F.H.) Engine idling speed	VM16SH/MIKUNI/1 3GB00 #80 ø1.2 3PZ5-3 D-8 (#559) 3.5 #12.5 ø0.7 1-1/8 ø1.2 2.5 ~ 4.5 mm (0.10 ~ 0.18 in) Below carburetor body edge 20.0 ~ 22.0 mm (0.79 ~ 0.87 in) 1,700 ~ 1,900 r/min
Lubrication system: Oil filter type Oil pump type Tip clearance <Limit> Side clearance <Limit> Bypass valve setting pressure	Wire mesh Trochoid type 0.15 mm (0.0059 in) <0.20 mm (0.0079 in)> 0.06 ~ 0.10 mm (0.0024 ~ 0.0039 in) <0.15 mm (0.0059 in)> 80 ~ 120 kPa (0.8 ~ 1.2 kg/cm ² , 11 ~ 17 psi)
Shaft drive: Middle gear backlash Final gear backlash	0.17 ~ 0.31 mm (0.007 ~ 0.012 in) 0.17 ~ 0.31 mm (0.007 ~ 0.012 in)

- ① Oil pump driven gear
- ② Oil pump
- ③ Oil pump cover gasket
- ④ Oil strainer
- ⑤ Drain plug
- ⑥ Oil pump

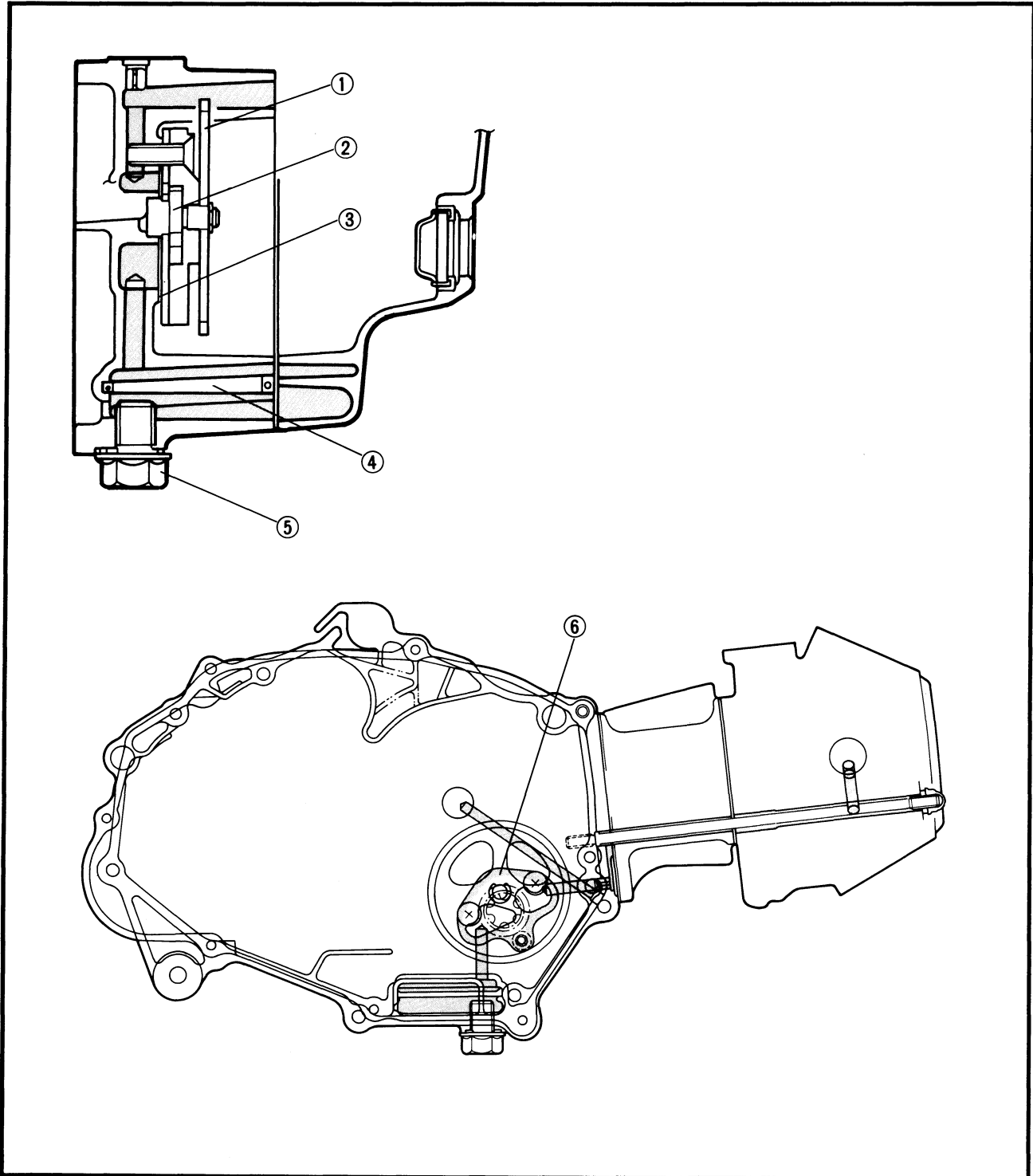



- Measure the valve clearance.
 - If the clearance is incorrect, repeat above steps until the proper clearance is obtained.
- *****

5. Install:

- Tappet covers (intake and exhaust)
- Side cover (cylinder head)
- Crankcase cover (left)
- Shift pedal

	Screw (cylinder head side cover): 7 Nm (0.7 m · kg, 5.1 ft · lb)
	Screw (left crankcase cover): 7 Nm (0.7 m · kg, 5.1 ft · lb)
	Bolt (shift pedal): 10 Nm (1.0 m · kg, 7.2 ft · lb)

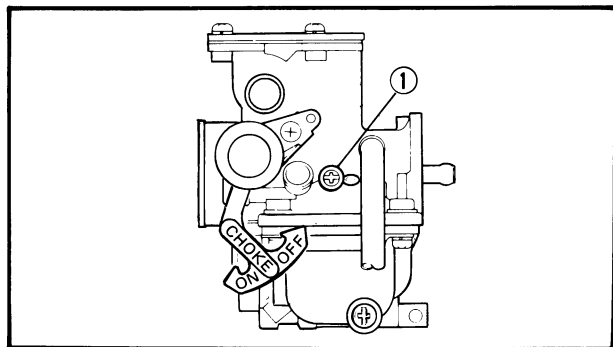

IDLE SPEED ADJUSTMENT

1. Adjust:

- Idle speed
Warm up the engine and turn the throttle stop screw ① to adjust.

	Idle speed: 1,700 ~ 1,900 r/min
--	---

THROTTLE LEVER ADJUSTMENT

NOTE: _____

Before adjusting the throttle lever free play, the engine idling speed should be adjusted.

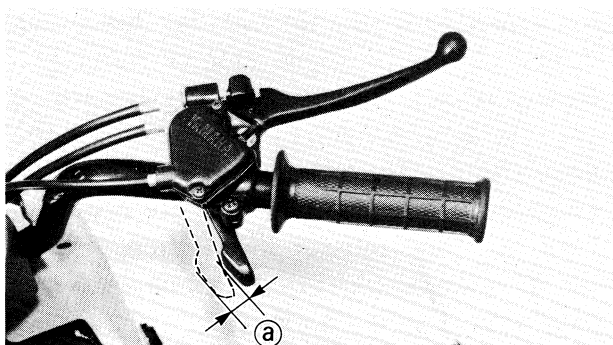

1. Place the machine on a level place.
2. Check:
 - Throttle lever free play ②
Out of specification → Adjust.

	Throttle lever free play: 3 ~ 5 mm (0.12 ~ 0.20 in)
--	---

- Turn it 1/8 counterclockwise.

NOTE: _____

Turn the adjuster counterclockwise to decrease the clutch free play and turn it clockwise to increase the free play.

- Tighten the locknut.



Locknut (clutch):
8 Nm (0.8 m • kg, 5.8 ft • lb)

3. Install:

- Cap cover



WHEEL BEARINGS CHECK

Front Wheel

1. Check:

- Front wheel bearings

Raise the front end of the machine, and spin the wheel by hand. Touch the front frame or knuckle while spinning the wheel. Excessive vibration → Replace bearings.

Rear Wheel

1. Block the front tire and raise the rear of the machine.

2. Check:

- Rear wheel bearings

Spin the wheel by hand and touch the rear wheel hub while spinning the wheel. Excessive vibration → Replace bearings.

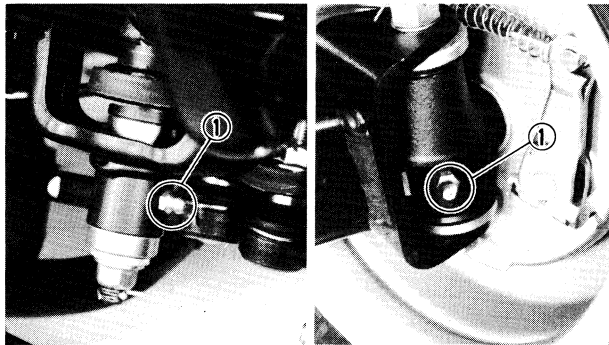

KNUCKLE SHAFT AND STEERING SHAFT LUBRICATION

1. Lubricate:

- Pivot points ①

Use a grease gun.



Lithium soap base grease

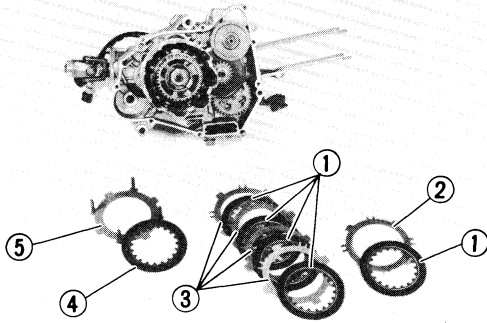

3. Remove:

- Friction plates ① (silver)
- Clutch plate ② (bent)
- Clutch plates ③
- Friction plate ④ (black)
- Thrust weight plate ⑤

4. Straighten:

- Lock washer tab

5. Remove:

- Nut ① (clutch boss)
- Lock washer
- Clutch boss assembly

NOTE:

Hold the clutch boss to loosen the nut (clutch boss) by the universal clutch holder ②.



Universal clutch holder:
YM-91042, 90890-04086

6. Remove:

- Balls ①
- Primary driven gear comp. ②

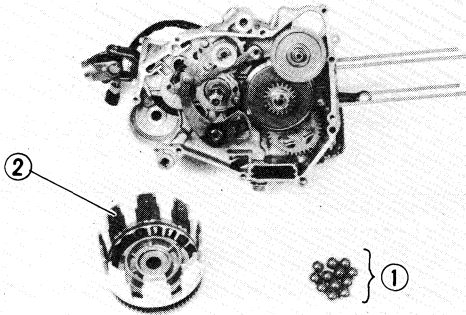

7. Remove:

- Spacer ①
- Thrust plate ②

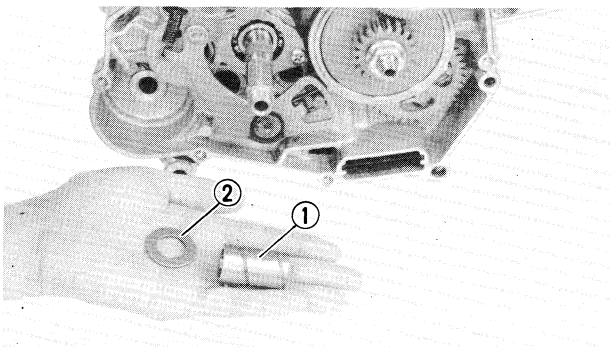

8. Remove:

- Push rod guide ①
- Push lever 1 ②

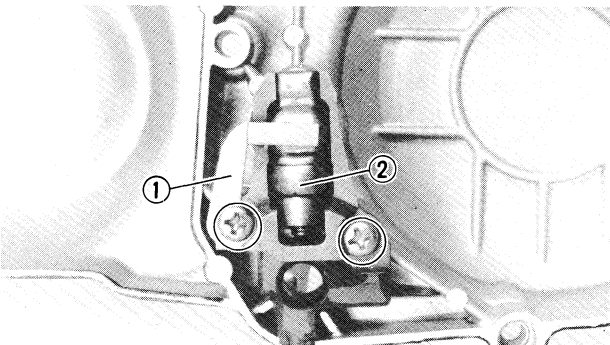



2. Clean the valve face to remove carbon deposits.

3. Inspect:

- Valve face
Pitting/Wear → Grind the face.

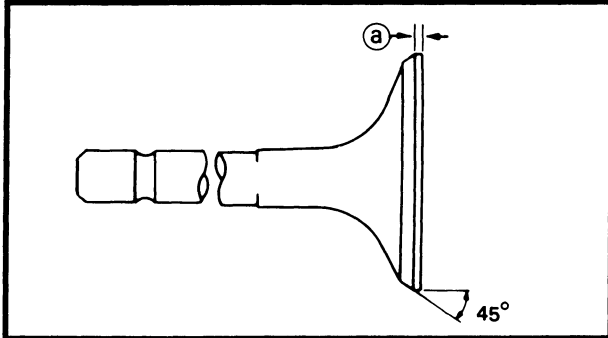

4. Measure:

- Margin thickness @
Out of specification → Replace.



Margin thickness limit:

Intake: 0.4 ~ 0.8 mm (0.016 ~ 0.032 in)

Exhaust: 0.8 ~ 1.2 mm (0.032 ~ 0.047 in)

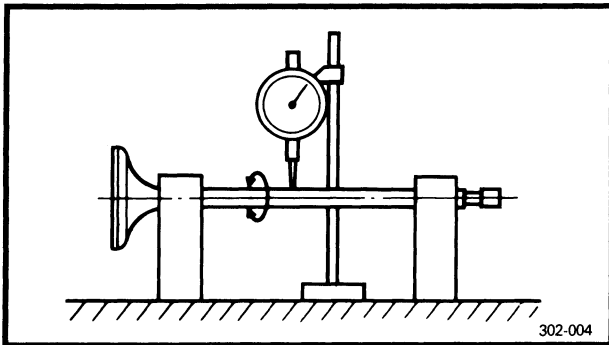

5. Check:

- Valve stem end
Mushroom shape or diameter larger than rest of stem → Replace.
- Runout
Out of specification → Replace.



Stem runout limit:

0.02 mm (0.0008 in)

NOTE:

- Always replace the guide if the valve is replaced.
- Always replace the oil seal if the valve is removed.

VALVE SEAT

1. Clean the valve face and valve seat to remove carbon deposits.

2. Inspect:

- Valve seat
Pitting/Wear → Reface the valve seat.



PISTON PIN

1. Inspect:

- Piston pin
Blue discoloration/Grooves → Replace then inspect lubrication system.

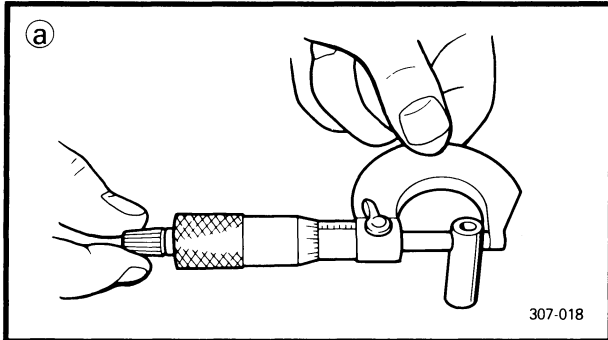

2. Measure:

- Outside diameter (a) (piston pin)
Out of specification → Replace.

 **Outside diameter (piston pin):**
12.996 ~ 13.000 mm
(0.5117 ~ 0.5118 in)

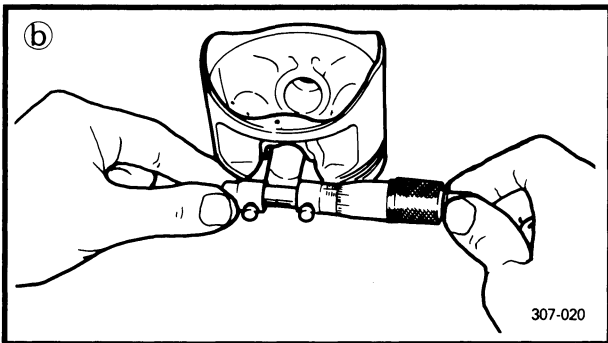

3. Measure:

- Piston pin-to-piston clearance
Out of specification → Replace piston.

Piston pin-to-piston clearance =
Bore size (piston pin) (b) –
Outside diameter (piston pin) (a)

 **Piston pin-to-piston clearance:**
0.002 ~ 0.017 mm
(0.0001 ~ 0.0007 in)
Limit: 0.07 mm (0.003 in)

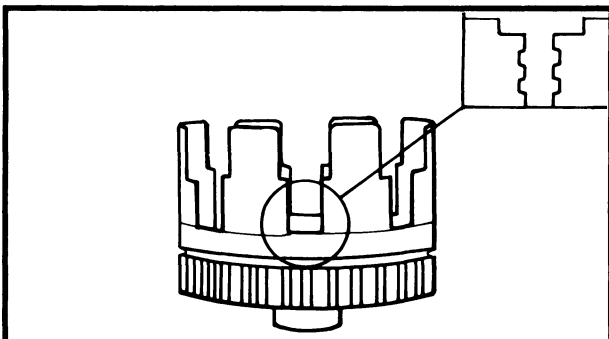

CLUTCH

1. Inspect:

- Dogs on the housing
Crank/Wear/Damage → Deburr or replace.
- Clutch housing bearing
Chafing/Wear/Damage → Replace.

NOTE:

Pitting on the clutch housing dogs will cause erratic operation.



CRANKSHAFT AND TRANSMISSION

- | | | |
|------------------------|-------------------------|-----------------------|
| ① Drive axle assembly | ⑪ 3rd pinion gear (22T) | ⑳ Crank (right) |
| ② 3rd wheel gear (31T) | ⑫ 2nd pinion gear (17T) | ㉑ Bearing |
| ③ Circlip | ⑬ Plain washer | ㉒ Oil pump drive gear |
| ④ 4th wheel gear (27T) | ⑭ Circlip | ㉓ Piston |
| ⑤ Plain washer | ⑮ Bearing | ㉔ Piston ring set |
| ⑥ 1st wheel gear (39T) | ⑯ Woodruff key | |
| ⑦ Circlip | ⑰ Crank (left) | |
| ⑧ Bearing | ⑱ Crank pin | |
| ⑨ Bearing | ⑲ Cylindrical bearing | |
| ⑩ Main axle | ⑳ Connecting rod | |

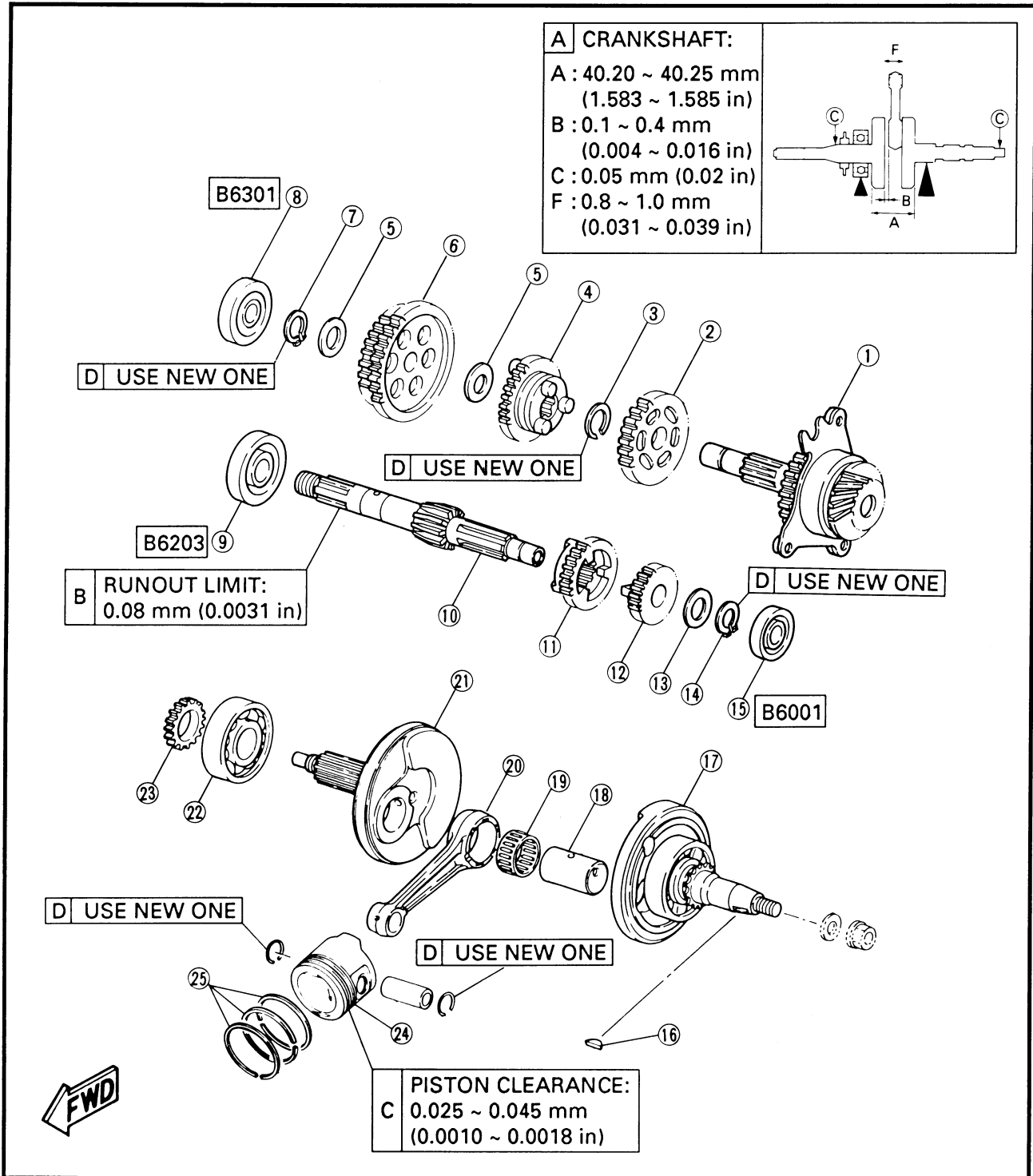

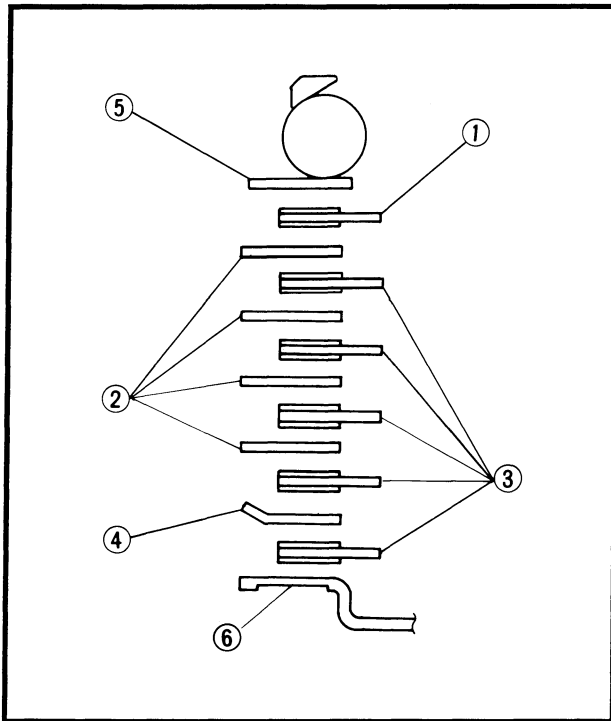

3. Install:

- Friction plate ① (black)
- Clutch plates ②
- Friction plates ③ (silver)
- Clutch plate ④ (bent)

- ⑤ Thrust weight plate
- ⑥ Pressure plate

NOTE:

Install the clutch plates and friction plates alternately on the clutch boss, starting with a friction plate and ending with a friction plate.

CAUTION:

- The friction plate (black) ① must be placed on the outside of the thrust weight plate.
- The clutch plate (bent) ④ must be placed on the inside of the first friction plate.

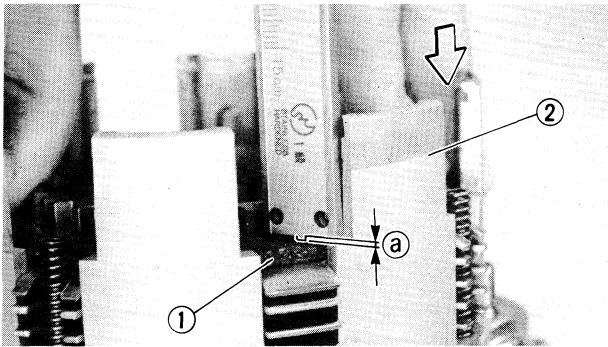

4. Adjust:

- Friction plate height

Adjustment steps:

- Push the friction plates ① down by hand.
- Measure the friction plate height ① (distance between the driven gear housing ② and friction plate ①.)

	Friction plate height ① : 1.30 ~ 1.65 mm (0.051 ~ 0.065 in)
--	---

- If the height is out of specification, adjust the friction plate height.
- Remove the following parts.
 - 1) Pressure plate
 - 2) Clutch plate (bent)
 - 3) Friction plates (silver and black)
 - 4) Clutch plates (4 pcs.)
- Select the suitable clutch plates (4 pcs.) by the following chart.

	Clutch Plates (4 pcs.)	
Thickness (mm)	1.2	1.4
	1.6	-



CARBURETION

CARBURETOR

- ① Throttle valve spring
- ② Needle set
- ③ Throttle valve
- ④ Throttle stop screw set
- ⑤ Pilot screw set
- ⑥ Choke lever
- ⑦ Pilot jet
- ⑧ Main nozzle
- ⑨ Main jet
- ⑩ Needle valve
- ⑪ Float
- ⑫ Drain screw

SPECIFICATION	
Main jet	#80
Jet needle	3PZ5-3
Pilot jet	#12.5
Pilot screw	1-1/8
Fuel level	2.5 ~ 4.5 mm (0.10 ~ 0.18 in)
Float height	20.0 ~ 22.0 mm (0.79 ~ 0.87 in)
Engine idling speed	1,700 ~ 1,900 r/min

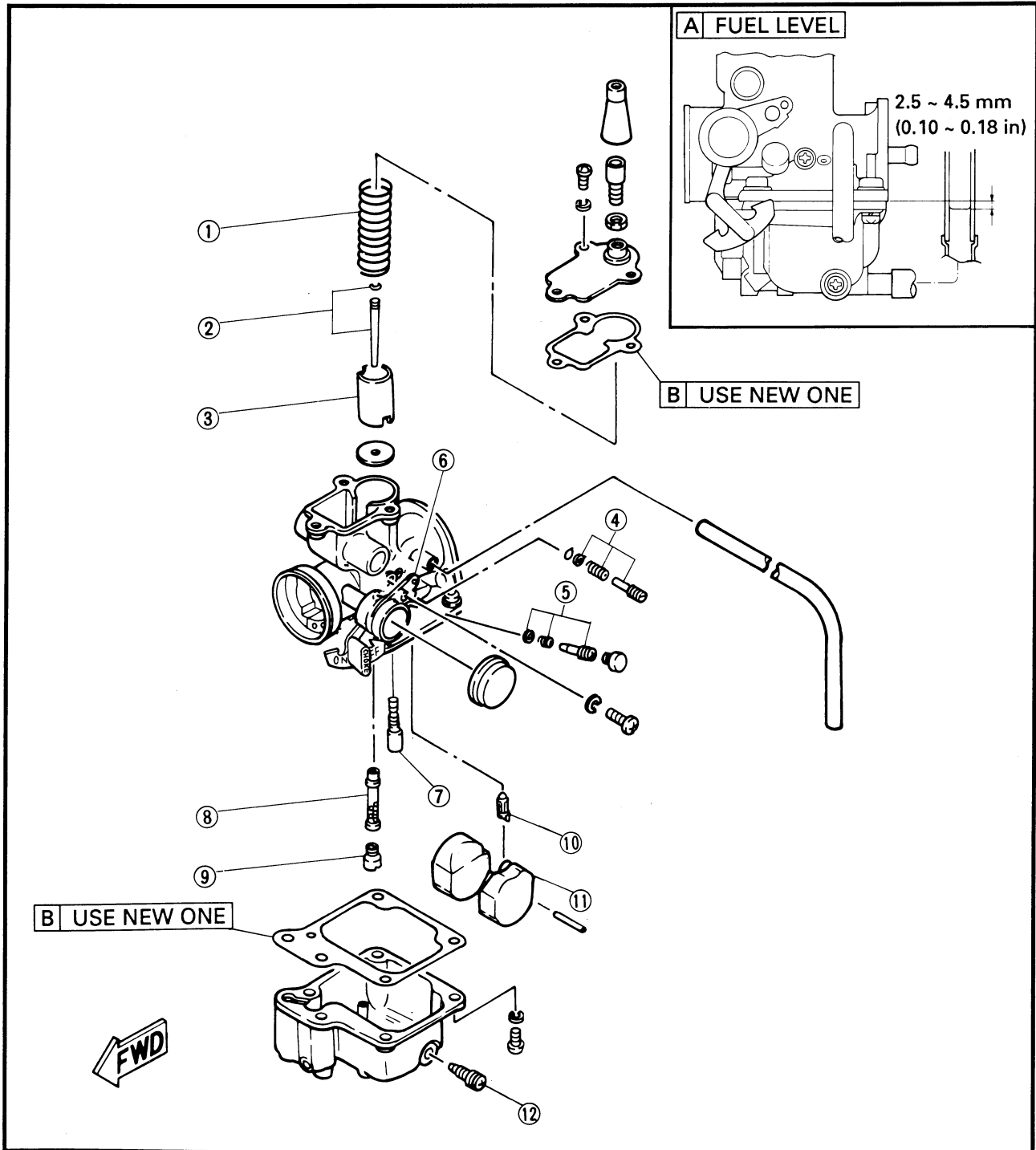

INSTALLATION

Reverse the "REMOVAL" procedure.
Note the following points.

1. Lubricate:
 - Oil seal lip
 - Bearing
 - Camshaft



Lithium-soap base grease

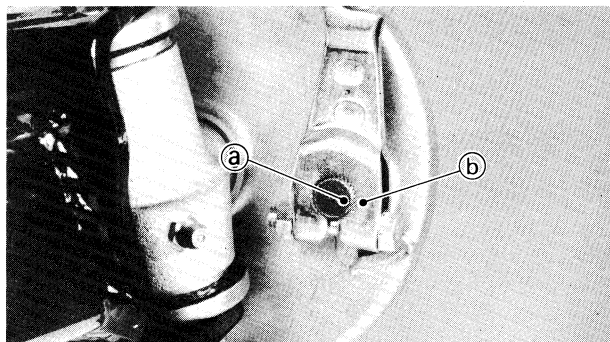

2. Install:

- Cam lever
- Camshaft
- Brake shoe plate
- Brake linings

NOTE:

- Align the punched mark (a) on the camshaft with the punched mark (b) on the cam lever.
- Be sure the boss (c) on the steering knuckle correctly engages with the projecting portion (torque stopper) (d) on the brake shoe plate.

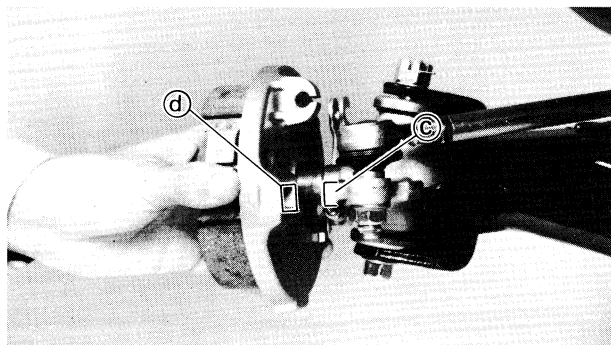

3. Connect:

- Brake cable (1)

NOTE:

Install the brake cable stopper (2) onto the brake cable (1) with the flat side (a) towards the brake shoe plate.

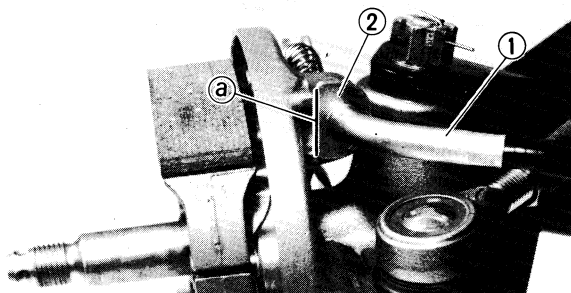

4. Tighten:

- Axle nut
- Nut (front wheel)



Axle nut:

70 Nm (7.0 m • kg, 50 ft • lb)

Nut (front wheel):

28 Nm (2.8 m • kg, 20 ft • lb)

REMOVAL**1. Remove:**

- Front cover
- Front fender

Refer to the "FRONT FENDER" section in the CHAPTER 3.

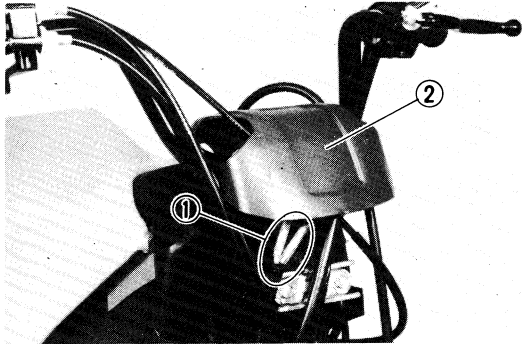
**2. Disconnect:**

- Neutral indicator light lead ①

3. Remove:

- Handlebar cover ②

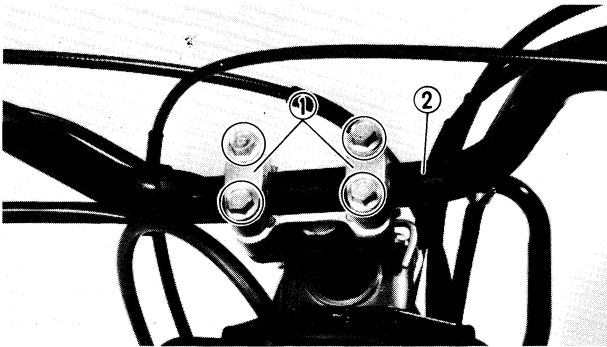
**4. Remove:**

- Handlebar holder ①
- Handlebar ②

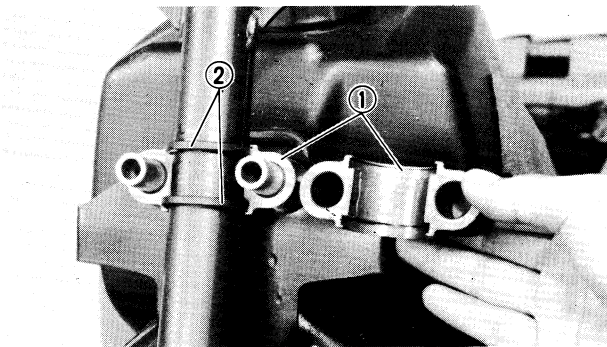
**5. Straighten:**

- Lock washer tabs

6. Remove:

- Steering shaft bracket
- Steering shaft bushings ①
- Oil seals ②

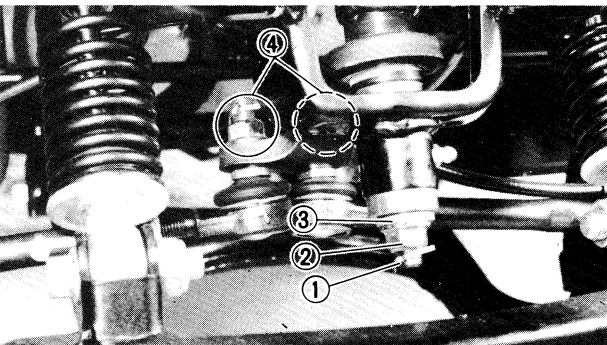
**7. Remove:**

- Cotter pin ①
- Nut ② (steering shaft)
- Plain washer ③
- Tie-rod end ④
- Steering shaft

REAR SHOCK ABSORBER AND SWINGARM

- ① Rear shock absorber
- ② Pivot shaft
- ③ Swingarm
- ④ Rubber boot

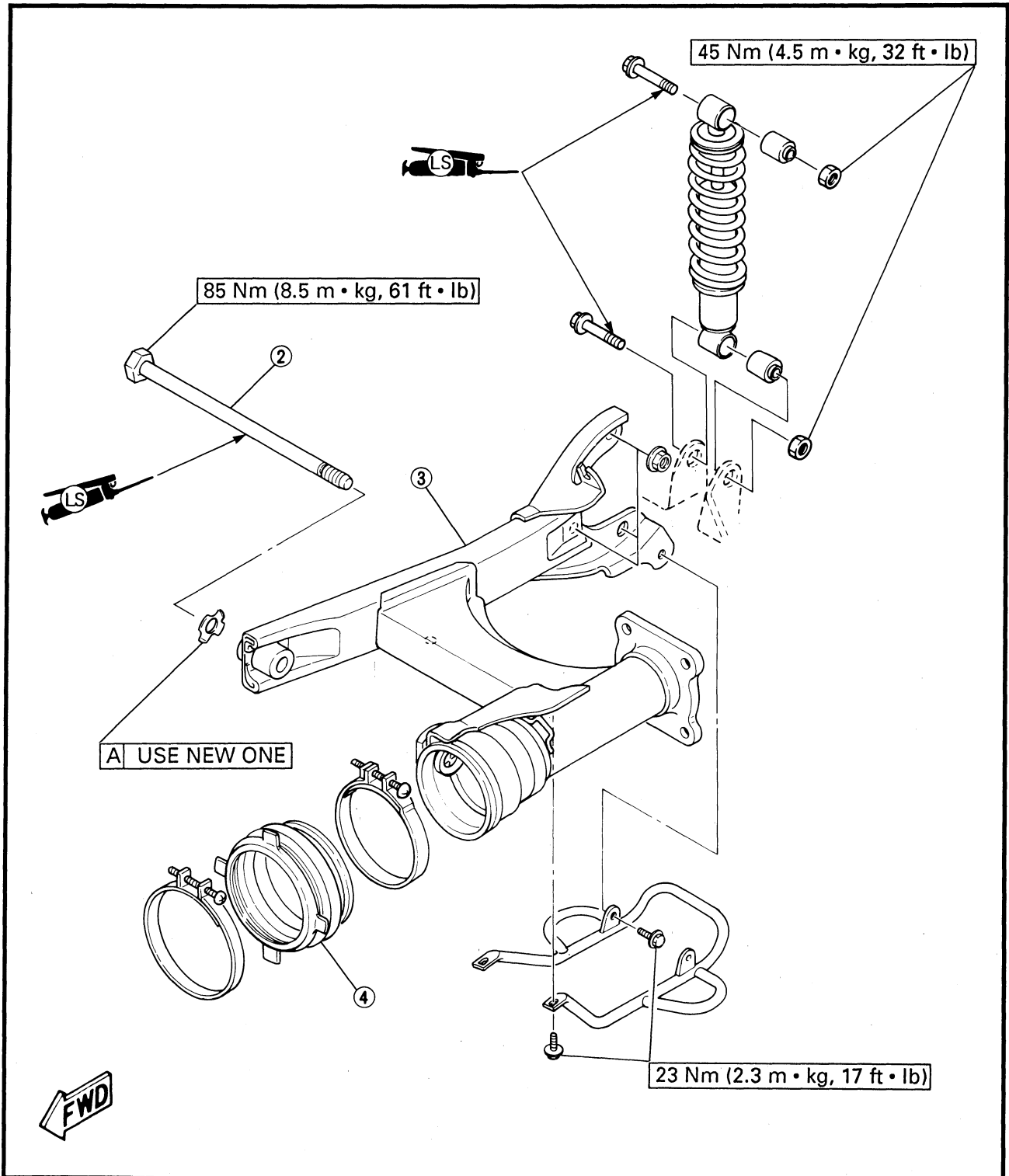



ELECTRICAL

YFM80 (D) CIRCUIT DIAGRAM

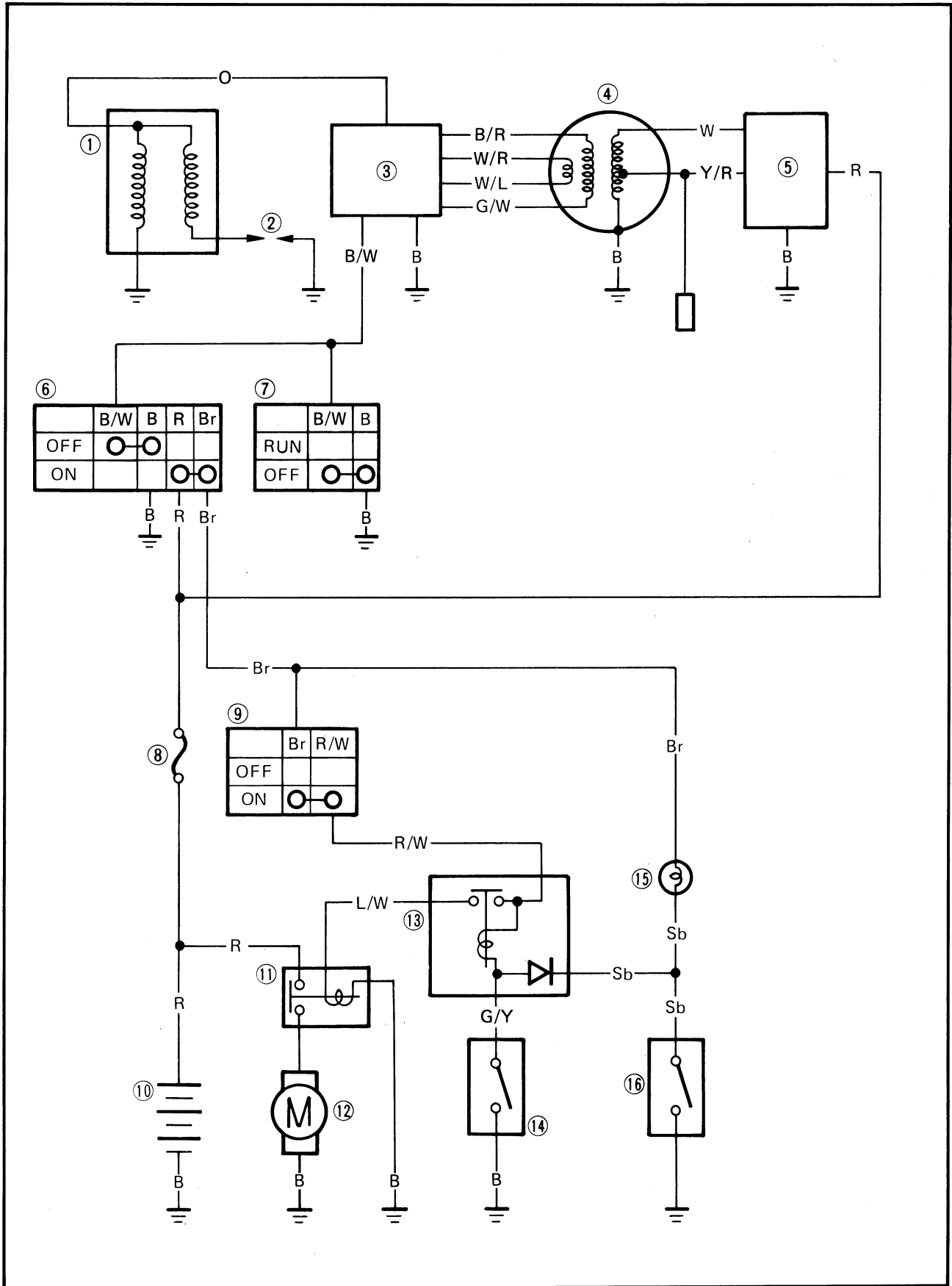

7



TROUBLESHOOTING

IF IGNITION SYSTEM SHOULD BECOME INOPERATIVE (NO SPARK OR INTERMITTENT SPARK)

Procedure

Check;

- 1. Spark plug
- 2. Ignition spark gap
- 3. Spark plug gap resistance
- 4. Ignition coil resistance
- 5. Main switch
- 6. "ENGINE STOP" switch
- 7. Pickup coil resistance
- 8. Source coil resistance
- 9. Wiring connection (entire ignition system)

NOTE:

- Remove the following parts before troubleshooting.
 - 1) Seat
 - 2) Front fender
 - 3) Fuel tank



Ignition checker:
 YM-34487
 90890-06754
Pocket tester:
 YU-03112
 90890-03112

1. Spark plug

- Check the spark plug condition.
- Check the spark plug type.
- Check the spark plug gap.

Replace to the "SPARK PLUG INSPECTION" section in the CHAPTER 3.

Standard spark plug:
 C7HSA (NGK), U22FS-U (N.D.)
 (For USA and OCE)
 CR7HS (NGK) (For EUR)



Spark plug gap:
 0.6 ~ 0.7 mm (0.024 ~ 0.028 in)



CORRECT

INCORRECT



Repair or replace spark plug.

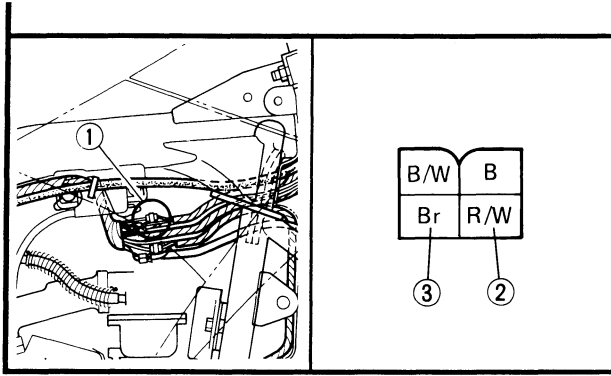

INCORRECT

Replace handlebar switch (right).

↓ CORRECT

12. Wiring connection

- Check the entire starting system for connections. Refer to the "WIRING DIAGRAM" section.

POOR CONNECTION

Correct.

CLICK HERE TO **DOWNLOAD** THE COMPLETE MANUAL

- Thank you very much for reading the preview of the manual.
- You can download the complete manual from: www.heydownloads.com by clicking the link below



- Please note: If there is no response to CLICKING the link, please download this PDF first and then click on it.

CLICK HERE TO **DOWNLOAD** THE COMPLETE MANUAL