

BRAKE SYSTEM

NDR030GB, NR045GB [B861]

CLICK HERE TO **DOWNLOAD** THE COMPLETE MANUAL

- Thank you very much for reading the preview of the manual.
- You can download the complete manual from: www.heydownloads.com by clicking the link below



- Please note: If there is no response to CLICKING the link, please download this PDF first and then click on it.

CLICK HERE TO **DOWNLOAD** THE COMPLETE MANUAL

Sideshift Cylinder Stroke	180 mm (7.09 in.)
Tilt Cylinder Stroke	36 mm (1.4 in.)
Fork Tilt Angle	
Down	3 degrees
Up	4 degrees

Battery Size Specifications

Model	Volts	Minimum Compartment Size Length x Width	Battery Size* Minimum/Maximum		Weight	
			Length	Width	Minimum	Maximum
NR035AE, NR040AE, NDR030AE, NS040/ 050AF	24	986 x 318 mm (38.8 x 12.5 in.)	986 mm (38.8 in.)	311.1 mm (12.25 in.)	568 kg (1250 lb)	863 kg (1900 lb)
		986 x 371 mm (38.8 x 14.6 in.)	986 mm (38.8 in.)	365 mm (14.38 in.)	681 kg (1500 lb)	953 kg (2100 lb)
		986 x 422 mm (38.8 x 16.6 in.)	986 mm (38.8 in.)	416 mm (16.38 in.)	726 kg (1600 lb)	1033 kg (2275 lb)
NR045CB, NDR030CB, NR045GB, NDR030GB	36	986 x 371 mm (38.8 x 14.6 in.)	986 mm (38.8 in.)	365 mm (14.38 in.)	704 kg (1550 lb)	953 kg (2100 lb)
		986 x 422 mm (38.8 x 16.6 in.)	986 mm (38.8 in.)	416 mm (16.38 in.)	840 kg (1850 lb)	1090 kg (2400 lb)
NR045CB, NDR030CB, NR045GB, NDR030GB	36	986 x 422 mm (38.8 x 16.6 in.)	986 mm (38.8 in.)	416 mm (16.38 in.)	840 kg (1850 lb)	1090 kg (2400 lb)
		986 x 478 mm (38.8 x 18.8 in.)	986 mm (38.8 in.)	473 mm (18.62 in.)	999 kg (2200 lb)	1294 kg (2850 lb)
		986 x 536 mm (38.8 x 21.1 in.)	986 mm (38.8 in.)	530 mm (20.88 in.)	1135 kg (2500 lb)	1362 kg (3000 lb)

Compartment width is across the width of the lift truck. Battery length installed across lift truck, battery width installed front to back.

*Maximum height for all batteries is 787 mm (31.0 in.).



WARNING

The battery must fit the battery compartment so the battery restraint system will operate correctly. Use the specified spacers to prevent the battery from moving more than 13 mm (0.5 in.) in any horizontal direction.

NOTE: Maximum tolerances are +0 and -13 mm (+0 and -0.5 in.) for the size of the battery compartment. The battery specification chart shows the maximum size tolerances that will permit the battery to still fit into the battery compartment.

General

This section describes disassembly and assembly, brush installation, inspection, and checks for malfunctions of DC motors. Inspect the commutator and brushes every 350 hours of operation. The commutator is the rotating electric connection between the armature and the electric power supplied by the battery. Brushes made of carbon compounds slide on the rotating commutator and are the path for electricity from the battery to the commutator and the armature. The maintenance of the commutator and the brushes is important to the good operation of a DC motor.

Traction motors and hydraulic pump motors are similar in design. The hydraulic pump motors are smaller than the traction motors, but the disassembly and maintenance of these motors are similar. The cooling fan in

the traction motors is fastened to the armature and can be removed from the armature. The cooling fan can be removed during disassembly of the traction motor.

The cooling fan in the hydraulic pump motors can be a press fit on the armature shaft and is not easily removed during disassembly of the motor. The armature and cooling fan must be removed from the drive end of the motor during disassembly.

The assembly and disassembly of the motor used for the power steering pump is described in the Steering System section. This motor is a permanent magnet motor.

Brush and Commutator Inspection

HYDRAULIC PUMP MOTOR AND TRACTION MOTOR

NOTE: The brushes and commutator can be inspected, the brushes can be replaced, and Stoning the Commutator can be done with the motor installed in the truck.

NOTE: Inspect the brushes and commutator every 350 hours for best operation and to prevent motor damage. The hydraulic pump motor normally has more start cycles than other motors, so it can have more wear and possible damage.

NOTE: The following procedure is for inspecting the brushes and commutator with the motor installed in the lift truck. The same inspections can be done with the motor removed. If the motor is removed, start at Step 3.

1. To rotate the commutator of the traction motor without moving the truck, the drive wheels must be raised. See Figure 1. Raise drive wheels so commutator of the traction motor can be rotated without moving lift truck. See **How To Raise Drive Wheels** in the **Operating Manual** or the **Periodic Maintenance** YRM section for your lift truck.

NOTE: For some models of lift trucks, the battery does not need to be removed to access the electric motors. Other models will require the removal of the battery before gaining access to the electric motors. To remove

the battery, either raise the hood panels or unfasten the floor plate, depending on which motor needs to be accessed.

2. Remove battery. See **How to Remove Battery** in the **Operating Manual** or the **Periodic Maintenance** YRM section for your lift truck. Remove access plate to motors. If the battery in your lift truck does not need removal for access to the motors, go to Step 3.

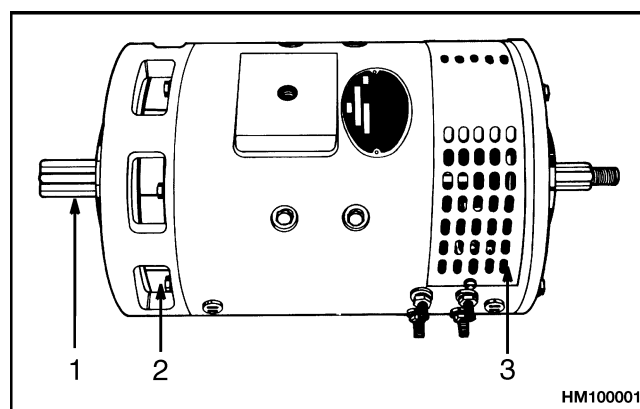

- | | |
|------------------------------|----------------|
| 1. ARMATURE
(DRIVE) SHAFT | 2. COOLING FAN |
| | 3. BRUSH COVER |

Figure 1. Traction Motor

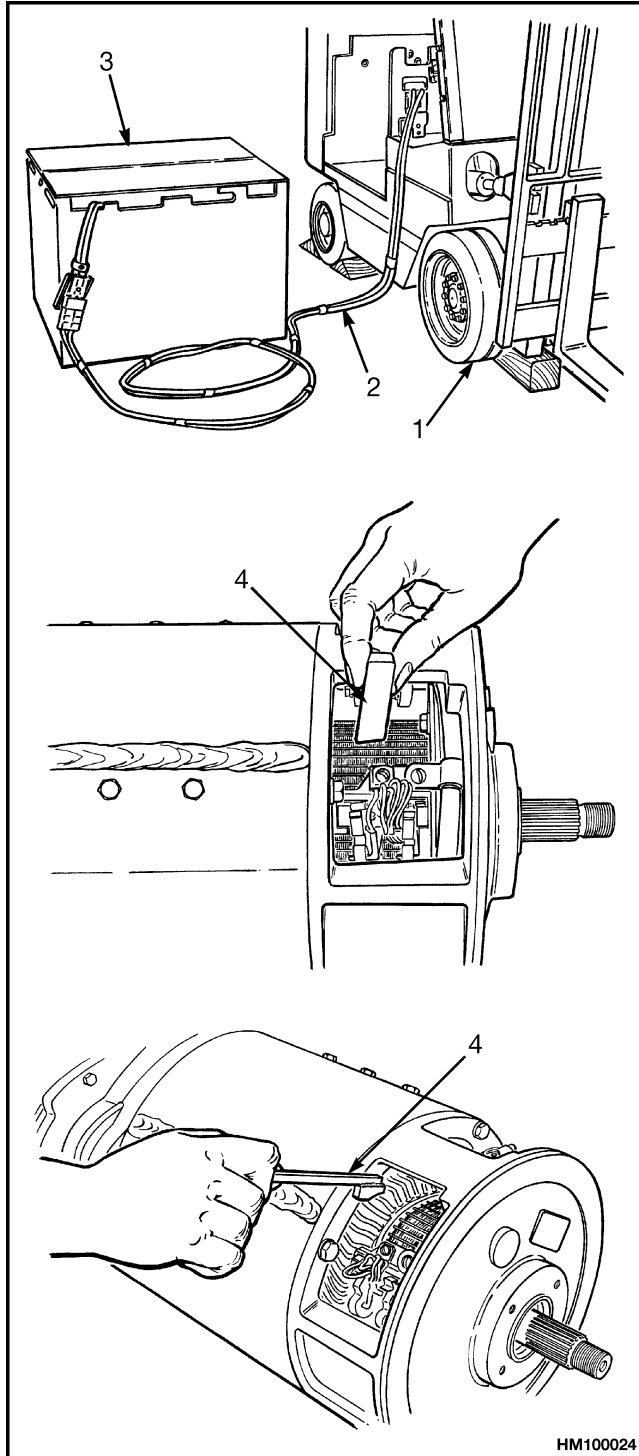

Legend for Figure 6

- | | |
|-----------------------|-----------------------|
| 1. RAISE DRIVE WHEELS | 3. BATTERY |
| 2. JUMPER | 4. BRUSH SEATER STONE |

Figure 6. Stoning the Commutator

TEST FOR SHORT CIRCUIT IN ONE ARMATURE WINDING

A short circuit in a motor winding is difficult to test because of the normal low resistance (less than 1 ohm) of a good armature. Special equipment is necessary to check for a short circuit in a motor winding. A motor with a short circuit in an armature winding will have a different sound when it begins to operate, but a service person must have experience to hear and understand the difference in sound. A winding with a short circuit will also run hotter than a good winding and can have indications of heat damage. A winding that shows heat damage when the other windings are normal can have a short circuit.

Another indication of a short circuit will be a higher than normal current draw by the motor. A higher than normal current draw can also indicate other problems or needed adjustments and does not always indicate a short circuit in a motor winding.

TEST FOR SHORT CIRCUIT TO ARMATURE SHAFT

NOTE: Clean the dirt and brush dust from the commutator area before making a test for a short circuit.

An ohmmeter ($R \times 10,000$ scale) can be used to test for a short circuit between an armature winding and the armature shaft. Put one probe on the armature shaft and the other probe on a commutator bar. See Figure 16. A resistance of less than 1 megohm indicates a problem between a winding and the armature shaft.

TEST FOR OPEN CIRCUIT IN FIELD COIL

The field windings in large electric motors normally have less than 1 ohm of resistance. If an ohmmeter ($R \times 1$ scale) is used to check the resistance between the two terminals of the winding, a resistance greater than 1 ohm indicates a problem in that winding or corrosion in the terminal connection. See Figure 17.

TEST FOR SHORT CIRCUIT IN FIELD COIL

A short circuit in a motor field winding is difficult to test because of the normal low resistance (less than 1 ohm) of a good field. Special equipment is necessary to check for a short circuit in a motor winding. A motor with a short circuit in a field winding will have a different sound when it begins to operate, but a service person

must have experience to hear and understand the difference in sound. A winding with a short circuit will also run hotter than a good winding and can have indications of heat damage.

Another indication of a short circuit will be a higher than normal current draw by the motor. A higher than normal current draw can also indicate other problems or needed adjustments and does not always indicate a short circuit in a motor winding.

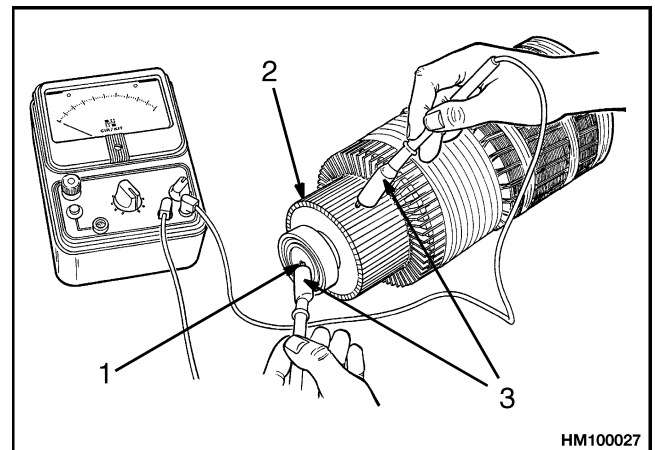

1. ARMATURE SHAFT
2. COMMUTATOR
3. PROBES TO OHMMETER

Figure 16. Test for Armature Short Circuit

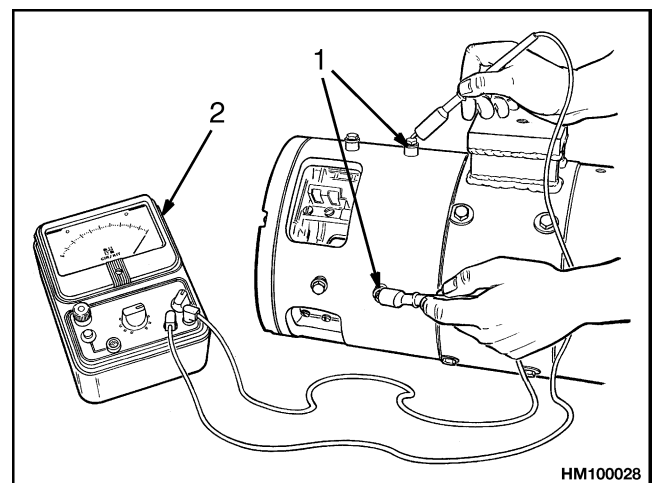

1. FIELD COIL TERMINAL
2. OHMMETER

Figure 17. Test for Open Field Circuit

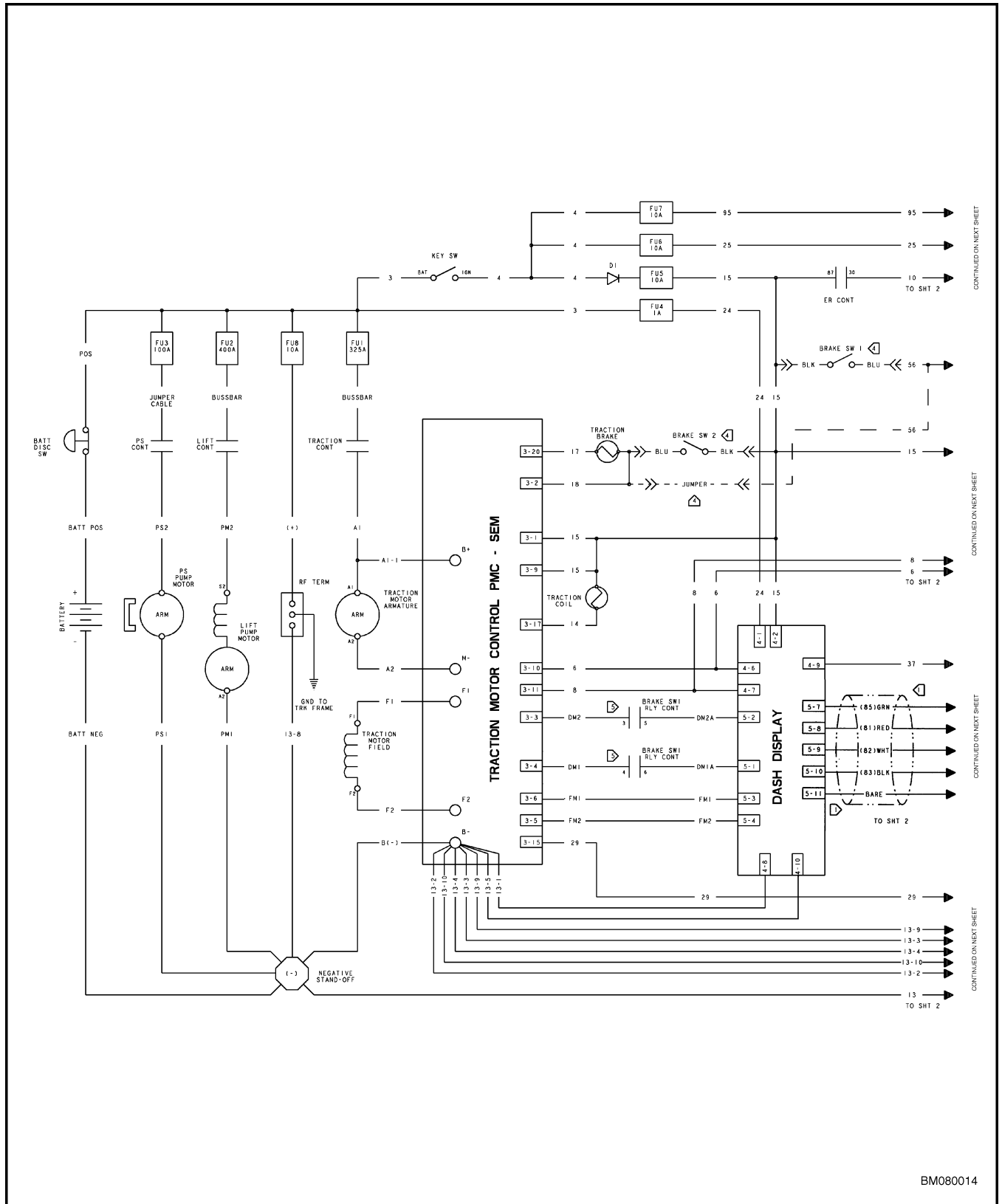

Figure 1. Schematic Diagram SEM MIB - II (Sheet 1 of 5)

BM080014

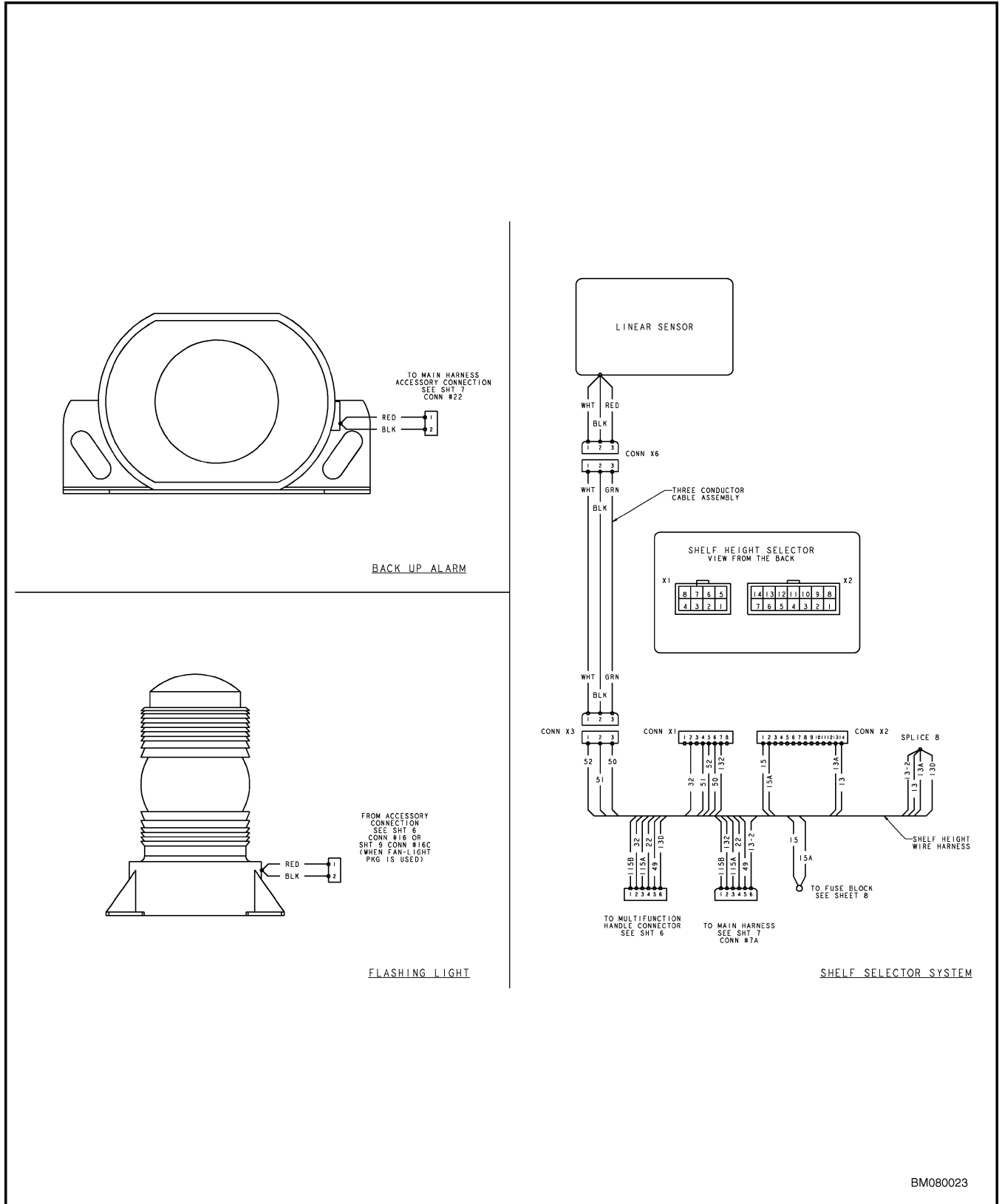

Figure 3. Wiring Diagram Optional Equipment SEM MIB - II (Sheet 2 of 2)

BM080023

General

The electrical control system consists of the following major components (see Figure 1):

- Main Interface Board (MIB)
- Proportional Electro-Hydraulic Valve
- SEM Traction Motor Controller
- Dash Display Assembly
- Control Handle Assembly
- Contactor Panel Assembly

See the section **Diagrams** 8000 YRM 982 or 8000 YRM 980 for additional information.

NOTE: Throughout this manual, the terms right, left, front, and rear relate to the viewpoint of an operator standing in the truck facing the forks.

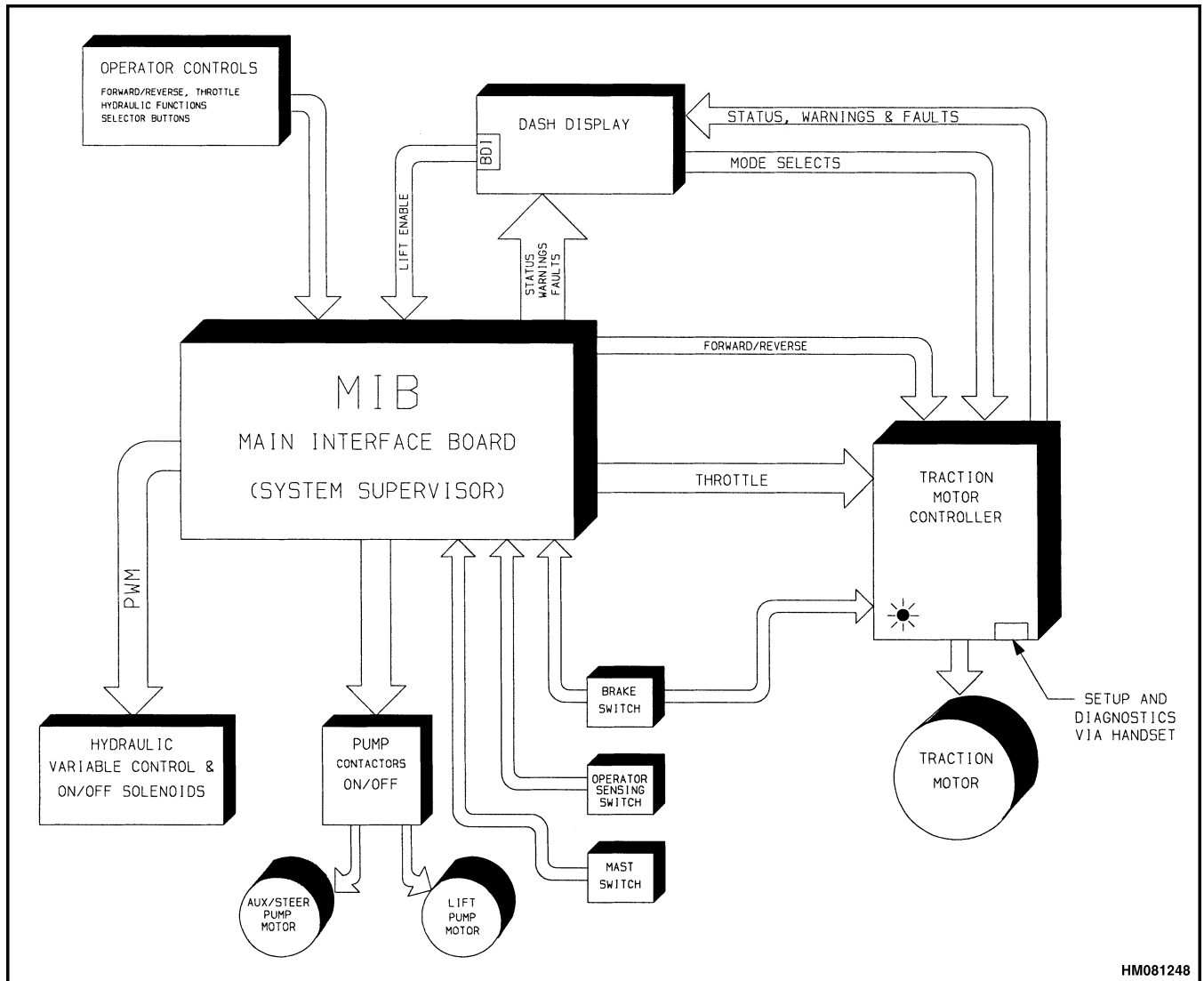

Figure 1. Logic Diagram

HM081248

Fuses

The fuses are located on the contactor panel assembly. Lift off the cover for access to the contactor panel assembly.



WARNING

Disconnect the battery and separate the connector before opening the compartment cover or inspecting/repairing the electrical system. If a tool causes a short circuit, the high-current flow from the battery can cause an injury or parts damage.

When the lift truck has the provision for EE, the fuses FU1, FU2, and FU3 are enclosed in a fuse box on the contactor panel assembly. For access to the fuses, see Figure 6. Remove the capscrews and lockwashers retaining the floor insulator, wall insulator, and the fuse box enclosure to the base plate to test or remove the fuses.

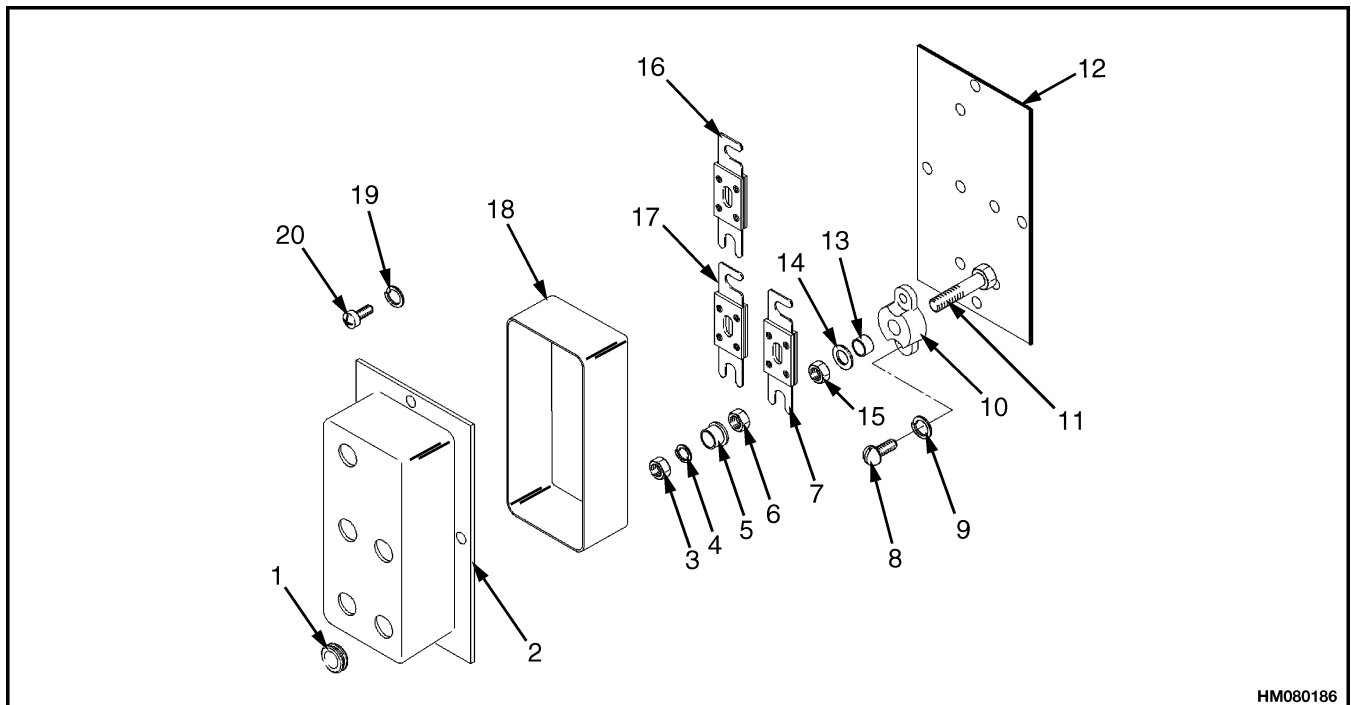

HM080186

- | | |
|-------------------------|-----------------------|
| 1. INSULATOR - TERMINAL | 11. CAPSCREW |
| 2. ENCLOSURE - FUSE BOX | 12. INSULATOR - FLOOR |
| 3. NUT | 13. SPACER |
| 4. LOCKWASHER | 14. WASHER |
| 5. SPACER | 15. NUT |
| 6. LOCK NUT | 16. FUSE 400 AMPS |
| 7. FUSE 100 AMPS | 17. FUSE 325 AMPS |
| 8. SCREW | 18. INSULATOR - WALL |
| 9. WASHER | 19. LOCKWASHER |
| 10. TERMINAL POST | 20. CAPSCREW |

Figure 6. Enclosed Fuse Box EE Application

- Remove the battery compartment cover for access to the MIB.

**WARNING**

The capacitor in the traction motor controller can hold an electrical charge after the battery is disconnected. To prevent electrical shock and injury, discharge the capacitor before inspecting or repairing any component. Wear safety glasses. Make certain the battery has been disconnected. Discharge the capacitors in the controller by connecting a load (such as a contactor coil or a horn) across the controller's B+ and B- terminals. **DO NOT use a screwdriver to discharge the traction motor controller.**

- Discharge the controller by connecting a load across terminals B+ and B-. See Figure 15. Disconnect the two plugs from the main interface board (MIB).

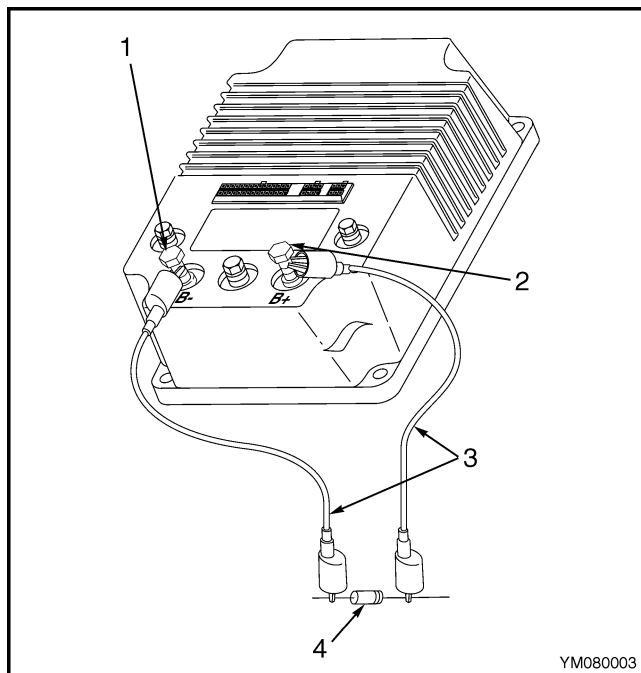

- NEGATIVE CONNECTION
- POSITIVE CONNECTION
- INSULATED JUMPER WIRES
- 200-OHM, 2-WATT RESISTOR

Figure 15. Discharging the Capacitors

- Remove the screws retaining the MIB to the MIB bracket.
- Remove the capscrews and lockwashers retaining the MIB bracket to the lift truck frame.

- Use a screwdriver in the slot of the lock on the connector to release the male plug. Pull and hold the lock away from the latch while pulling the J plugs from the MIB. See Figure 16. Disconnect both the J1 (white) and J2 (black) plugs from the MIB.

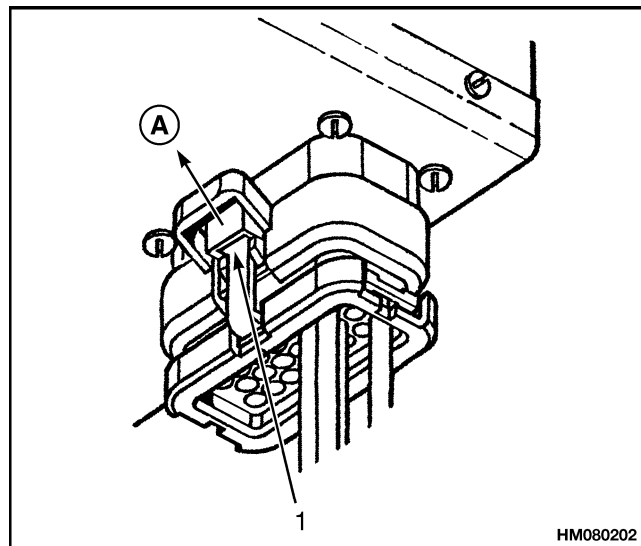

NOTE: PULL LOCK AWAY FROM THE CONNECTOR TO DISCONNECT.

A. PULL

- INSERT SCREWDRIVER INTO SLOT

Figure 16. MIB J Connector

- Lift the MIB bracket high enough to allow removal of the MIB.

NOTE: The MIB is not a repairable item and must be replaced if there is a problem with the board itself.

MIB, INSTALL**WARNING**

Disconnect the battery and separate the connector before opening the compartment cover or inspecting/repairing the electrical system. If a tool causes a short circuit, the high-current flow from the battery can cause an injury or parts damage.

- Move the lift truck to a safe, level area. Turn the key switch **OFF** and remove the key. Put a DO NOT OPERATE tag on the control handle. Put blocks under the drive wheels to keep the lift truck from moving. See **Periodic Maintenance** 8000 YRM 970. Refer to How To Put The Lift Truck On Blocks.

Table 13. MIB Function Code Values for NDR030CB (Continued)

Description	Default Value	Min./Max.
Forward-Maximum*	219	0/+239
Mast Up Speed*	130	0/+143
NOTE: *Not more than 255.		

Table 14. MIB Function Code Values for NR045GB Mast Full Height less than 333 Inches

Description	Default Value	Min./Max.
Drive Dead Band 1 (DDB1)	32	16/DDB2
Drive Dead Band 2 (DDB2)	64	DDB1/130
Hydraulic Dead Band 1 (HDB1)	32	16/HDB2
Hydraulic Dead Band 2 (HDB2)	64	HDB1/130
Hydraulic Ramp	70	40/120
Slow Reach (SRCH)	95	80/FRCH
Fast Reach (FRCH)	160	SRCH/200
NOTE: *Not more than 255.		

Table 14. MIB Function Code Values for NR045GB Mast Full Height less than 333 Inches (Continued)

Description	Default Value	Min./Max.
Slow Retract (SRT)	80	70/FRT
Fast Retract (FRT)	130	SRT/160
Tilt Down	95	0/105
Tilt Up	120	0/150
Sideshift Right	95	0/110
Sideshift Left	95	0/110
36 Volt		
Lift-Minimum	25	10/80
Lift-Maximum	190	80/210
Lower-Minimum	30	10/80
Lower-Maximum	170	80/190
Lift Neutral	15	15/30
Lower Neutral	20	10/30
36 Volt E		
Reverse-Maximum*	250	0/+255
Forward-Maximum*	250	0/+255
Mast Up Speed*	130	0/+143
NOTE: *Not more than 255.		

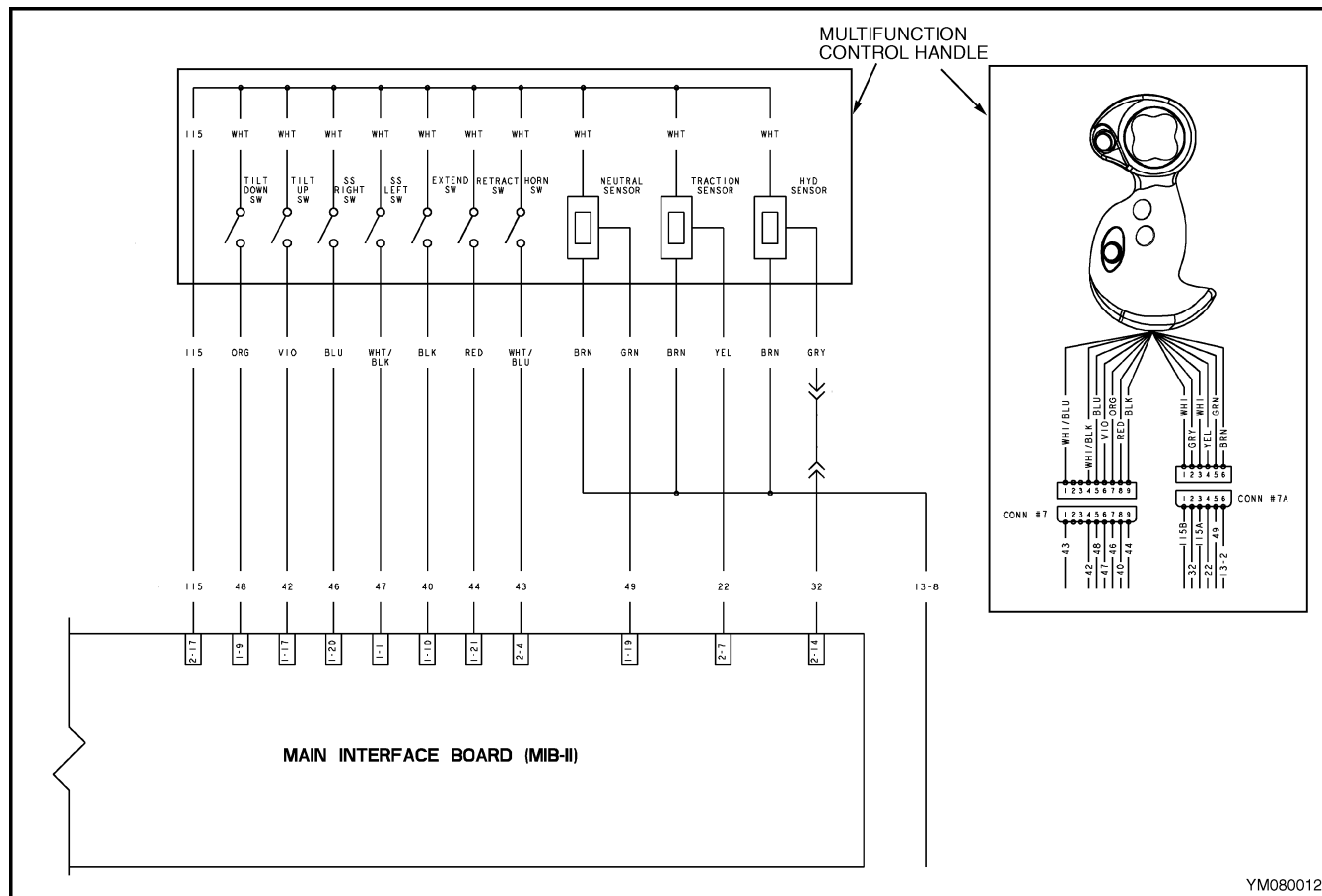

Figure 18. Multifunction Control Handle Plug - Pin and Wire Identification

MIB Code	Dash Display Message	Priority Level	Code Type	Signal Source
06XX	LIFT	27	STATUS	MIB
Condition Multifunction control handle positioned for LIFTING.		Logic Displayed when MIB terminal J2-17 is 12 volts and MIB terminal J2-14 increases from the neutral value.		
Truck Response Yellow LIFT/LOWER indicator illuminates. Lift pump starts and forks lift.				

MIB Code	Dash Display Message	Priority Level	Code Type	Signal Source
07XX	LOWER	27	STATUS	MIB
Condition Multifunction control handle positioned for LOWERING.		Logic Displayed when MIB terminal J2-17 is 12 volts and MIB terminal J2-14 decreases from the neutral value.		
Truck Response Yellow LIFT/LOWER indicator illuminates. Forks lower.				

MIB Code	Dash Display Message	Priority Level	Code Type	Signal Source
XX57	HYDRAULIC HANDLE ERROR	12	FAULT	MIB
<p>Condition Hydraulic signal from handle is outside of neutral band, but the neutral signal is high.</p> <p>Truck Response Lift - lower are disabled until brake is cycled.</p> <p>Possible Causes and Test Procedures</p> <ul style="list-style-type: none"> • Neutral band is much too small; handle fault; faulty wiring. 		<p>Refer to the Wiring Schematics</p> <p>Logic Hydraulic signal from handle is outside of neutral band, but the neutral signal is high.</p>		

MIB Code	Dash Display Message	Priority Level	Code Type	Signal Source
XX58	HYDRAULIC HANDLE ERROR	12	FAULT	MIB
<p>Condition Hydraulic signal from handle is too low.</p> <p>Truck Response Lift - lower are disabled until brake is cycled.</p> <p>Possible Causes and Test Procedures</p> <ul style="list-style-type: none"> • Handle fault; faulty wiring. 		<p>Refer to the Wiring Schematics</p> <p>Logic Hydraulic signal from handle is less than 0.2 volt.</p>		

MIB Code	Dash Display Message	Priority Level	Code Type	Signal Source
XX59	HYDRAULIC HANDLE ERROR	12	FAULT	MIB
<p>Condition Hydraulic signal from handle is too high.</p> <p>Truck Response Lift - lower are disabled until brake is cycled.</p> <p>Possible Causes and Test Procedures</p> <ul style="list-style-type: none"> • Handle fault; faulty wiring. 		<p>Refer to the Wiring Schematics</p> <p>Logic Hydraulic signal from handle is greater than 4.8 volts.</p>		

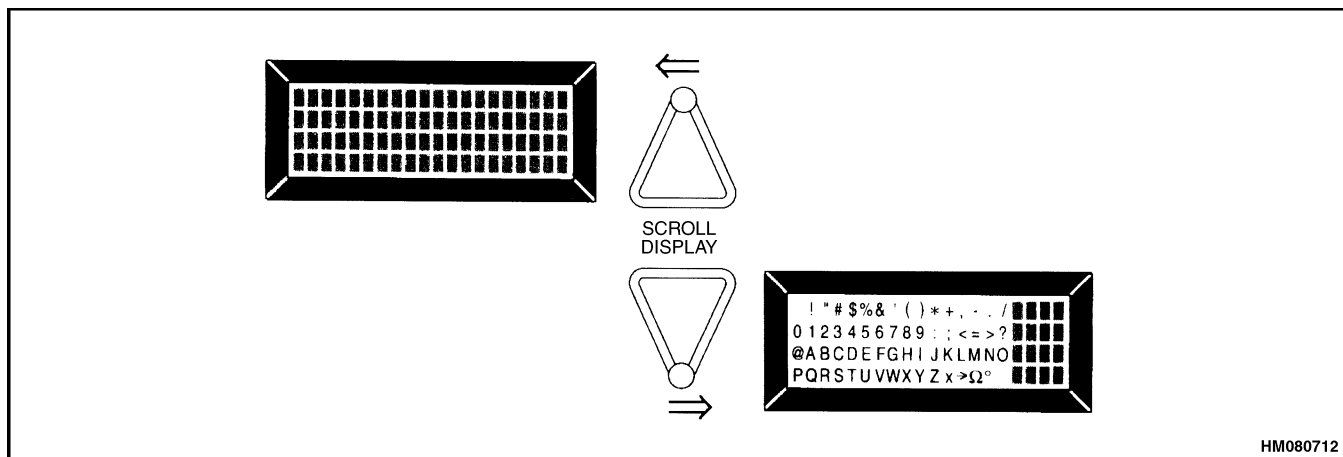

Figure 23. Programmer Handset Self Test

OPERATING MODES

Program Menu

Press the PROGRAM key to enter the PROGRAM mode. See Table 18. The LED in the corner of the PROGRAM key illuminates to indicate that the programmer has been placed in the PROGRAM mode. All of the adjustable functions and features are shown in the display window, four at a time, with the corresponding settings. The setting of the selected item (the item at the top of the display with the flashing arrow) can be changed using the CHANGE VALUE keys. The CHANGE VALUE keys have LEDs to indicate whether the key can be used to increase or decrease the value any further. When the LED is no longer lit, the limit for the key direction has been reached.

Press the MORE INFO key to display more detailed information for the setting selected, including a bar graph indicating the position of the current setting relative to the range for the setting, the unit of measure, and the specific minimum and maximum values for the setting. If the range is limited by the values assigned for a different function, the name of the limiting function is displayed in place of the minimum and maximum values.

Table 18. Program Menu

Program Menu Display	Description
M3 Brake C/L	Mode 3 braking current, in amps
M2 Brake C/L	Mode 2 braking current, in amps

Table 18. Program Menu (Continued)

Program Menu Display	Description
M1 Brake C/L	Mode 1 braking current, in amps
M3 Neut Brk %	Mode 3 neutral braking, as % of brake C/L
M2 Neut Brk %	Mode 2 neutral braking, as % of brake C/L
M1 Neut Brk %	Mode 1 neutral braking, as % of brake C/L
M3 Accel Rate	Mode 3 acceleration rate, in seconds
M2 Accel Rate	Mode 2 acceleration rate, in seconds
M1 Accel Rate	Mode 1 acceleration rate, in seconds
Taper Rate	Regen braking decrease rate, when transitioning to plug, in 1/32 seconds
M3 Max Speed	Mode 3 maximum speed, as % of top speed
M2 Max Speed	Mode 2 maximum speed, as % of top speed
M1 Max Speed	Mode 1 maximum speed, as % of top speed

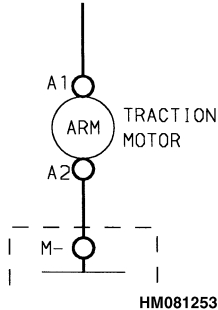
LED Code	Dash Display Message	Programmer Handset Display Message
1, 3	DRIVE CTRL FAULT CHECK FAULT CODE	M- FAULT
<p>Condition Handset is plugged into the traction motor controller. Key switch is in the ON position. Diagnostic menu is selected.</p> <p>Truck Response Traction is disabled until fault condition is corrected.</p> <p>Possible Causes and Test Procedures</p> <ul style="list-style-type: none"> M- output shorted or internal short in the traction motor. Verify voltage between battery- and M- to be 10% less than battery volts, with the multifunction control handle in neutral. Traction motor shorted. Check traction motor for shorted condition. 		 <p style="text-align: right;">HM081253</p>
		<p>Logic M- bus bar should measure approximately 10% less than battery volts. Pin 2-7 should measure near zero volts, with multifunction control handle in neutral. Pin 2-7 should measure near battery voltage, with corresponding direction selected.</p>

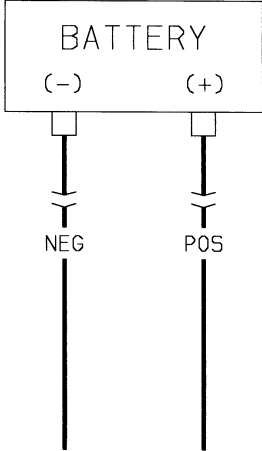
LED Code	Dash Display Message	Programmer Handset Display Message
4, 2	DRIVE CTRL LIMIT SPEED REDUCED	OVERVOLTAGE
		OVERVOLTAGE
<p>Condition Handset is plugged into the traction motor controller. Key switch is in the ON position. Diagnostic menu is selected.</p> <p>Truck Response Traction is disabled until fault condition is corrected.</p> <p>Possible Causes and Test Procedures</p> <ul style="list-style-type: none"> Truck voltage greater than 45 volts. Check to ensure proper battery is in the truck. Plugging the charger into the truck instead of the battery can also cause this fault. Check to ensure the proper battery charging procedure is followed. 		 <p style="text-align: right;">HM080718</p>
		<p>Logic Traction controller is designed to operate with 24- and 36-volt batteries only.</p>

Legend for Figure 2

- | | |
|-------------------|-------------------------------|
| 1. WASHER | 13. CLIPNUT |
| 2. LOCKWASHER | 14. LOCKWASHER |
| 3. CAPSCREW | 15. CAPSCREW |
| 4. CAPSCREW | 16. CAPSCREW |
| 5. MOUNTING CLIP | 17. SPRING CLIP |
| 6. CUSHION | 18. SPRING CLIP MOUNTING BAR |
| 7. CUSHION | 19. BATTERY COMPARTMENT COVER |
| 8. CUSHION | 20. BATTERY SIDE PLATE |
| 9. WASHER | 21. BATTERY ROLLER ASSEMBLY |
| 10. CAPSCREW | 22. LINER |
| 11. DOOR WELDMENT | 23. CAPSCREW |
| 12. HINGE PIN | |

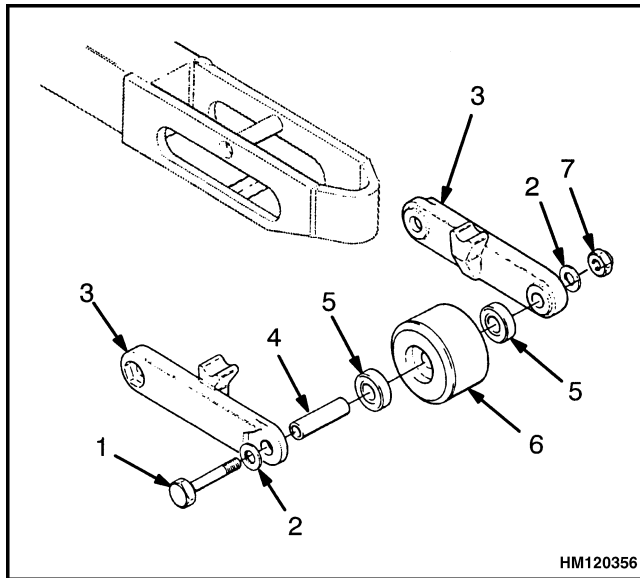

- | | |
|----------------|---------------|
| 1. AXLE SHAFT | 5. BEARING |
| 2. WASHER | 6. LOAD WHEEL |
| 3. BRACKET | 7. NUT |
| 4. AXLE SLEEVE | |

Figure 3. Tandem Load Wheels

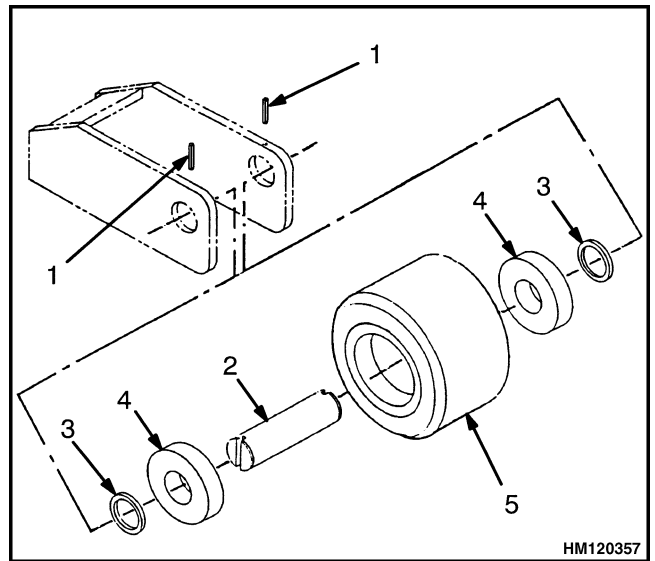

- | | |
|-------------|------------------------|
| 1. ROLL PIN | 4. BEARING |
| 2. AXLE | 5. LOAD WHEEL ASSEMBLY |
| 3. SPACER | |

Figure 4. Single Load Wheel

TABLE OF CONTENTS

General.....	1
Description	1
Control Handle.....	2
Description	2
Control Valve	2
Description	2
Trucks built before 15 July, 2002	3
Trucks built after 15 July, 2002	3
Control Valve-Manual Lowering	3
Trucks built before 15 July, 2002	3
Trucks built after 15 July, 2002	3
Remove	4
Install.....	4
Lift Pump and Motor	5
Description	5
Remove	5
Install.....	7
Disassemble.....	7
Assemble	7
Steering Pump.....	8
Hydraulic Tank.....	8
Description	8
Remove and Disassemble	8
Assemble and Install	9
Schematics	10
Figure 9. Hydraulic Schematic (Trucks built before 15 July, 2002).....	10
Figure 10. Hydraulic Schematic (Trucks built after 15 July, 2002)	11
Figure 11. Hydraulic Tank - Exploded View (Small Chassis)	12
Figure 12. Hydraulic Tank - Exploded View (Large Chassis).....	13
Troubleshooting	14

This section is for the following models:

NDR030GB, NR045GB [B861];
 NDR030AE, NR035/040/045AE [C815];
 NS040/050AF [C816];
 NDR030CB, NR045CB [D829]

5. Install the fittings in the manifold block.
6. Remove the filler cap from the tank.
7. Remove two screws and lockwashers attaching the strainer-filter to the tank cover. Remove the strainer-filter.
8. Using a siphoning pump, insert the suction hose into the hydraulic tank. Siphon out the hydraulic fluid from the tank into a container of suitable size.
9. On top of the tank, tag and remove three hoses which connect to breather, hydraulic filter, and steering control unit. Install plugs into the hose connections to prevent dirt from entering the system. Wipe up any hydraulic fluid that may have leaked during removal.
10. To access the lower hoses, first remove the hydraulic oil filter element. Then tag and remove the two suction hoses which connect to the steer pump and lift pump. Install plugs into the hose connections to prevent dirt from entering the system. Wipe up any hydraulic fluid that may have leaked during removal.
11. Tag and remove the power cables from the lift pump motor. Position cables away from the tank to allow room for removal.
12. If required, tag and remove the hoses which connect between the control valve and the mast assembly, and between the control valve and the lift pump. Install plugs into hose connections.
13. Remove the hydraulic tank from the lift truck.
14. If required, take off the tank cover and gasket by removing four lock nuts and washers.
2. Replace the hydraulic tank in the lift truck.
3. If disconnected, remove tags and plugs and reconnect hoses between the control valve and mast assembly, and between the control valve and lift pump.
4. Reconnect the power cables to the lift pump and remove the tags.
5. On the bottom of the tank, remove the tags and plugs and replace the two suction hoses which connect to the steer pump and lift pump. Replace the hydraulic oil filter element.
6. On top of the tank, remove the tags and plugs, and replace the three hoses which connect to the breather, hydraulic filter, and steering control unit.
7. Attach the strainer filter to the tank cover with two screws and lockwashers.
8. Fill the hydraulic tank with the recommended hydraulic oil. Refer to Table 1 for hydraulic tank capacities. See the **Periodic Maintenance** 8000 YRM 970 or the **Operator Manual** for fluid specifications.
9. Remove the blocks from under the drive/steer wheel, caster wheels, and load wheels.
10. Reconnect the battery.
11. Operate the lift truck through all functions. Check for oil leaks. Recheck the hydraulic tank for the correct oil level. Add oil if required.
12. Install the front and rear compartment covers. See the section **Frame** 100 YRM 975 for installation procedure. Refer to Covers, Panels, and Plates.

ASSEMBLE AND INSTALL

1. Replace the tank cover and gasket, if removed, with four lock nuts and washers.

INDUSTRIAL BATTERY

ALL ELECTRIC LIFT TRUCKS

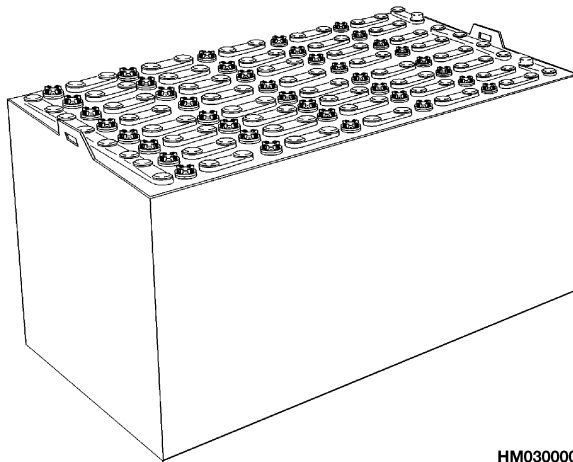

HM030000

CLEANING BATTERY

Keep the battery compartment clean and dry. Use a clean cloth to wash the battery with water. Dry with compressed air.

 **CAUTION**

Do not clean the battery with steam or hot water. Do not use a high-pressure hose.

Remove any electrolyte from the battery compartment to prevent corrosion. If there is electrolyte on the top of the battery, apply a solution of bicarbonate of soda. Mix a solution containing 0.5 kg of soda for every 4 liters of water. Apply the solution, then flush the solution from the battery with clean water. Wash the battery and battery compartment as needed, but within a 6 month period as the maximum time.

NOTE: If the top of the battery is wet from electrolyte, check that the electrolyte level is not too high or the battery charger is not operating correctly.

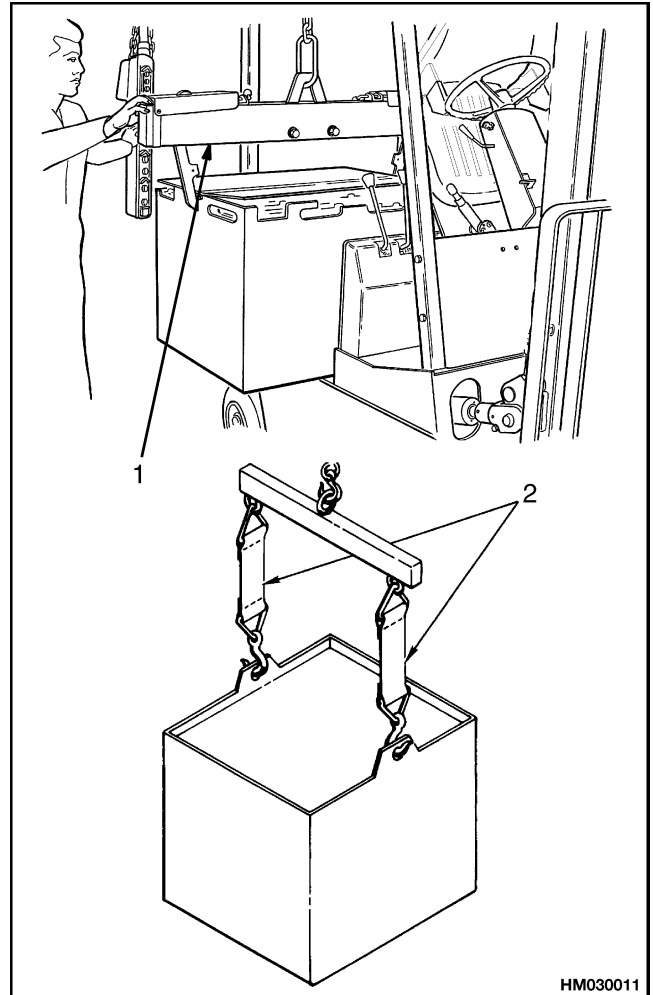

- 1. INSULATED SPREADER BAR
- 2. INSULATED STRAPS

Figure 10. Change the Battery

Battery Inspection Report Date _____									
Battery No. _____				Dept. Used In _____					
Battery Type _____				MFR. _____					
Serial No. _____				Date New _____					
Reading on Charge at _____ Amperes				Charger No. _____					
CELL NO.	CELL VOLTS	POSITIVE CADMIUM	SPECIFIC GRAVITY	TEMP.	CELL NO.	CELL VOLTS	POSITIVE CADMIUM	SPECIFIC GRAVITY	TEMP.
1					21				
2					22				
3					23				
4					24				
5					25				
6					26				
7					27				
8					28				
9					29				
10					30				
11					31				
12					32				

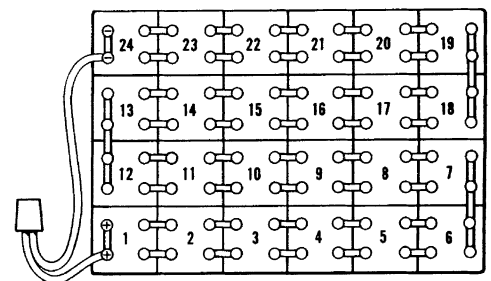

HM030012

Figure 11. Battery Inspection Report

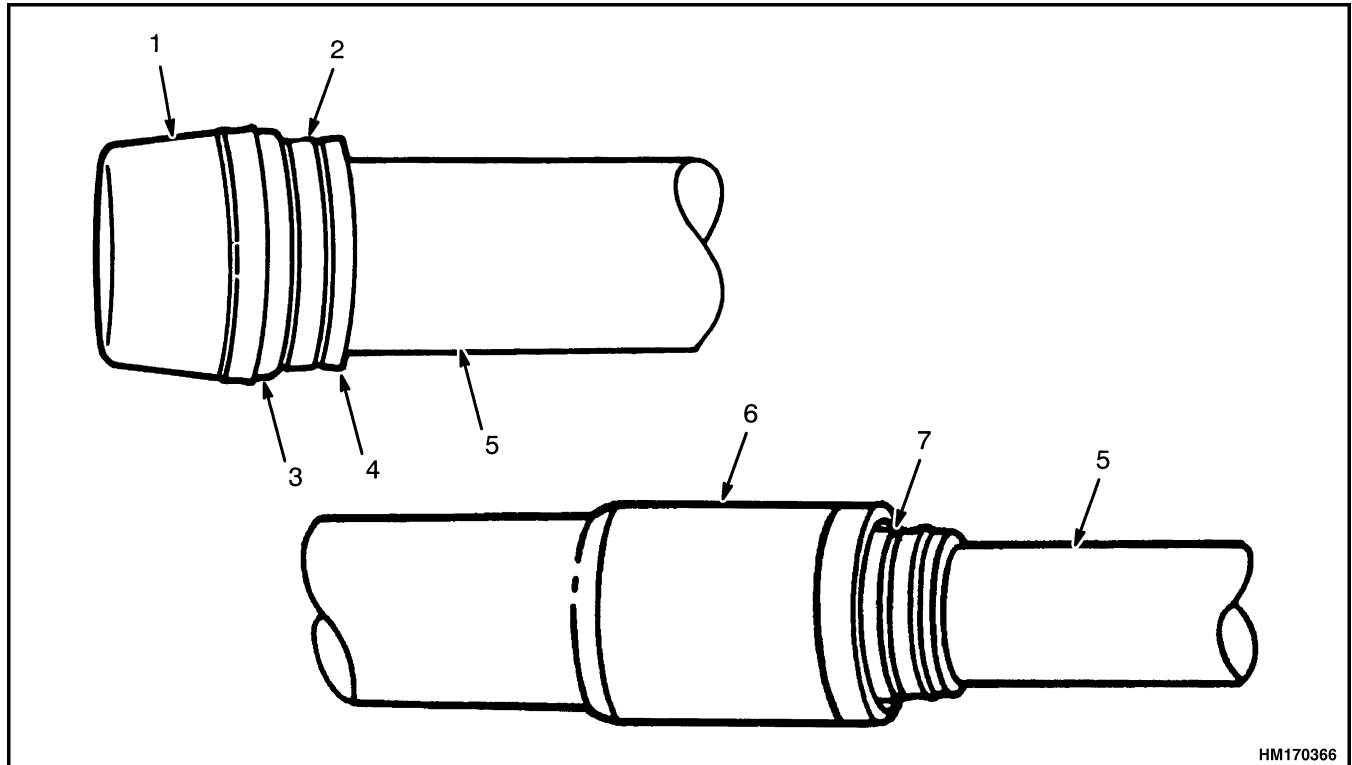

HM170366

- | | |
|---------------------------------|---------------------------------|
| 1. EXTERNAL INSTALLATION SLEEVE | 5. PISTON ROD |
| 2. SEAL | 6. CYLINDER SHELL |
| 3. WEAR RING | 7. INTERNAL INSTALLATION SLEEVE |
| 4. BACKUP RING | |

Figure 4. Seal Installation Sleeves

2. Install the seal and bearing (and spacer if equipped) on the piston rod. Use shim material and a clamp as a guide to move the seal past the threads of the shell.



CAUTION

A difficult and important step in assembling cylinders is the correct installation of the seals without damage. Most cylinder maintenance is caused by seal leakage. Special tools are available in the seal kit for correct installation of the seals.

3. Carefully push the piston and piston rod into the shell. Release the clamp on the seal when the seal travels past the threads of the shell.
4. Install the seals, O-rings, and wiper ring in the retainer. If the wiper ring has a spring backup ring, the spring must be toward the base of the lift cylinder.

5. Carefully install the retainer on the piston rod.
6. Engage the threads and tighten the retainer in the shell to 340 to 410 N•m (251 to 302 lbf ft). Use the correct spanner wrench. Do not hit the retainer with a hammer and driver.



CAUTION

Wrong installation of the special washer and spring can make the load lower too fast.

7. Install the lowering control valve. Make sure the special washer and the spring are installed correctly. A wrong installation can cause the load to lower too fast.
8. See the section **Mast - Repair 4000 YRM 482** for cylinder installation in the mast assembly.

CLICK HERE TO **DOWNLOAD** THE COMPLETE MANUAL

- Thank you very much for reading the preview of the manual.
- You can download the complete manual from: www.heydownloads.com by clicking the link below



- Please note: If there is no response to CLICKING the link, please download this PDF first and then click on it.

CLICK HERE TO **DOWNLOAD** THE COMPLETE MANUAL

General

This section has the descriptions and the operations for two-stage and three-stage mast assemblies with mast unit codes: A566, A567, A568, A569, A570, A571, A572, A573, A574, A575, A729, A730, A775, A776, and B736.

The mast unit code and serial number are stamped on the outside of the outer weldment of the mast.

The repair procedures for the mast assemblies are in **Mast Repair** 4000 YRM 482. The information for the main cylinders is in **Lift Cylinders** 4000 YRM 481. The information for the reach carriages is in **Reach Carriages** 4500 YRM 971.

A mast is used to raise a load vertically. Hydraulic cylinders are installed vertically on the masts. The cylinders

raise and lower the vertical frames or weldments and the reach or straddle carriage. These mast assemblies can be either two- or three-stage masts. See Figure 1. Each type of mast is described separately in this section.

The mast assemblies include the following parts:

- The outer mast weldment
- The inner mast weldment
- The intermediate mast weldment (three-stage only)
- The main cylinder(s)
- The free-lift cylinder (three-stage only)
- The load rollers
- The lift chains and sheaves
- The sheave support (three-stage only)
- The hydraulic tubing, hoses, and sheaves
- The electrical cable for the reach carriage

Mast Weldments

The main vertical frames of a mast assembly are called weldments. These weldments are assembled so they telescope. The inner mast weldment moves inside the outer mast weldment. The carriage moves inside the inner mast weldment. On a three-stage mast, there is an intermediate mast weldment located between the inner mast and outer mast weldments. The outer mast weldment is attached to the lift truck frame. The outer mast weldment can also be a support for the overhead guard on certain lift trucks.

When the telescopic weldments and the carriage lift a load, forces are put on the mast assembly. To decrease friction caused by these forces, load rollers, wear plugs,

side rollers, and thrust rollers are installed between the moving parts. Wear strips are also used on certain models. The side rollers and load rollers, with the wear plugs, travel along the channels within the weldments. The thrust rollers and wear strips travel on the outside edges of the weldments.

The two-stage masts have either one or two main hydraulic lift cylinders installed vertically on the outer weldment that raise the inner mast weldment. The three-stage masts have two main cylinders that raise the intermediate weldment, with lift chains raising the inner mast weldment, free-lift cylinder, and carriage. The free-lift cylinder raises lift chains that lift the carriage.

OPERATION

As the rods in the main cylinders extend, they move the inner mast weldment out of the outer mast weldment. See Figure 11. Since the chain sheaves are fastened to the inner mast weldment, the force from the cylinder rods transfer the lifting motion to the carriage.

The weight of the load, carriage, and inner mast weldment makes the rods retract to push the oil from the cylinders. The oil flows from the cylinders through the flow control valves, located at the base of the cylinders and in the manifold. It then flows to the hydraulic tank. Each main cylinder has a lowering control valve installed in its base. These lowering control valves control the lowering speed of a load if a hydraulic line breaks.

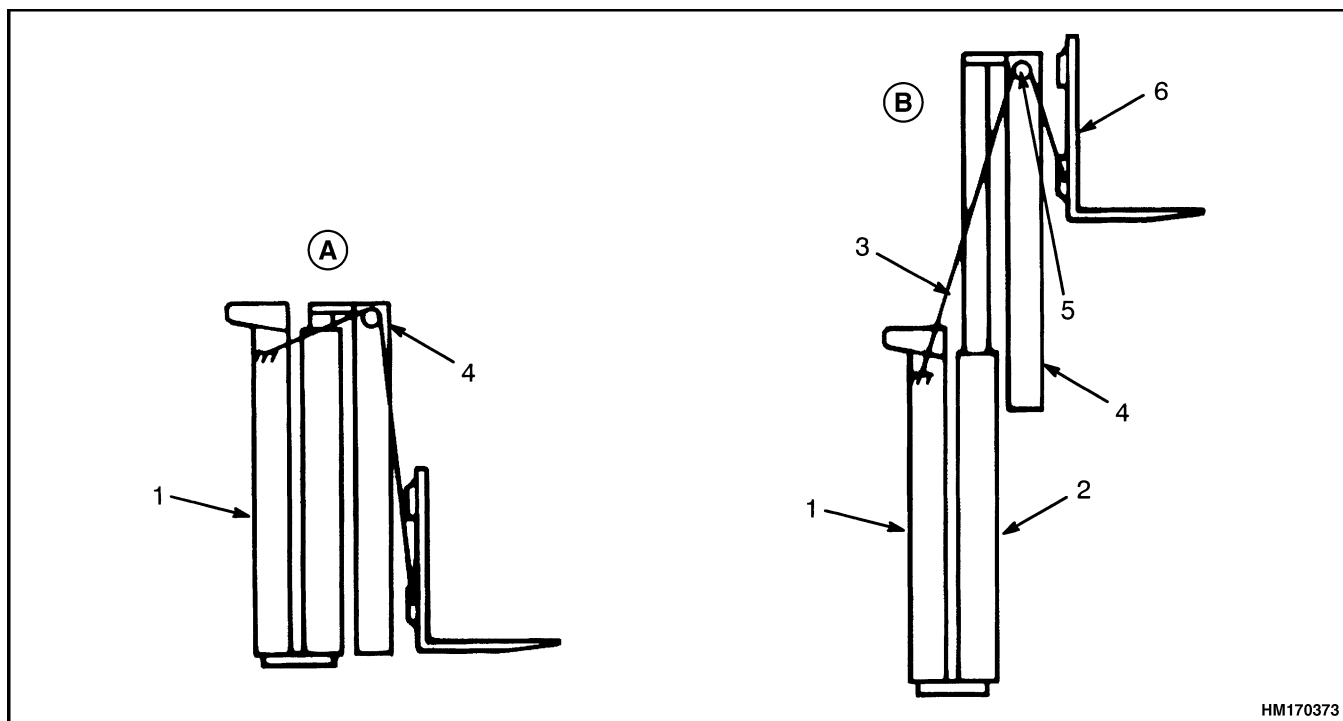

A. POSITION 1

1. OUTER WELDMENT
2. LIFT CYLINDERS (1 OR 2)
3. LIFT CHAINS (2)

B. POSITION 2

4. INNER WELDMENT
5. CHAIN SHEAVE (2)
6. CARRIAGE

Figure 11. Two-Stage Assembly Operation

Three-Stage Mast

DESCRIPTION

The three-stage mast assembly has three weldments. See Figure 12. There is an outer mast weldment, an intermediate mast weldment, and an inner mast weldment. The weldments are telescopic and have a load roller and wear strip (similar to the two-stage mast) or wear plug arrangement. The three-stage masts have three hydraulic cylinders: the free-lift cylinder and two

main cylinders. See Figure 13 and Figure 14. They are all single-stage lift cylinders. The free-lift cylinder fastens to the inner mast weldment and controls the movement of the carriage. The free-lift chains transfer force from the free-lift cylinder to the carriage. The two main cylinders fasten to the intermediate mast weldment and control the movement of the intermediate mast. The two outer lift chains transfer the force from the main cylinders to the inner mast weldment.

TABLE OF CONTENTS

General.....	1
Safety Procedures When Working Near Mast.....	1
Load Backrest Extension, Carriage, Load Rollers, Side Rollers, and Forks.....	3
Load Backrest Extension, Remove and Install.....	3
Carriage Assembly, Remove and Install.....	3
Carriage Load Rollers, Remove and Install.....	5
Side Rollers, Disassemble and Assemble.....	6
Fork, Replace.....	6
Forks - Hook Type.....	6
Remove	6
Install	8
Two-Stage Mast Assembly	8
Remove	8
Clean and Inspect	11
Lift Cylinders, Remove and Install Dual-Lift Cylinders	13
Lift Cylinder, Remove and Install Single-Lift Cylinders.....	14
Remove.....	14
Install	15
Inner Mast Assembly, Remove and Install	16
Hoses, Replace.....	16
Hose and Cable Sheaves, Replace	16
Two-Stage Lift Chains	18
Remove and Install	18
Clean and Inspect.....	18
Two-Stage Chain Sheave, Remove and Install	18
Load Rollers and Wear Plugs, Remove and Install.....	19
Two-Stage Mast Assembly, Install.....	20
Three-Stage Mast Assembly	21
Three-Stage Mast Assembly, Remove.....	21
Clean and Inspect	24
Free-Lift Cylinder, Remove and Install	24
Main Cylinders (Standard), Remove and Install.....	25
Inner and Intermediate Mast Assemblies, Remove and Install	27
Hoses, Replace.....	27
Hose and Cable Sheaves, Replace	27
Free-Lift Hose Sheave	29
Carriage Sheaves	29
Three-Stage Lift Chains, Remove and Install.....	30
General	30
Free-Lift Chains	30
Main-Lift Chains	30
Three-Stage Chain Sheaves, Disassemble and Assemble.....	30
Free-Lift Chain Sheaves	30
Main-Lift Chain Sheaves.....	31
Load Rollers and Wear Plugs, Remove and Install.....	31
Three-Stage Mast Assemble, Install	32
Mast Operation Check.....	33
Hydraulic System Leaks Check.....	33
Lift Chains Check	34
General	34
Clean and Inspect	34

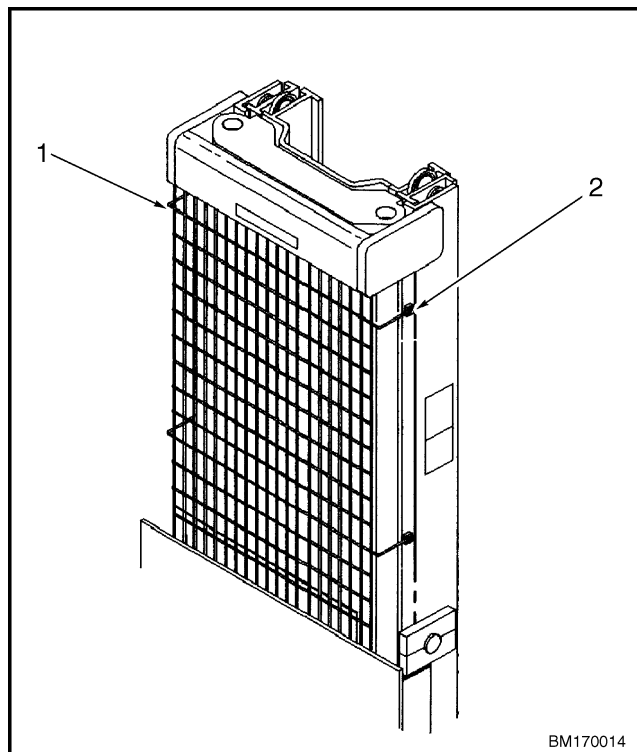

1. OPERATOR
GUARD

2. CAPSCREW

Figure 9. Operator Guard Walkie High Lift Trucks

2. For the Narrow Aisle lift trucks, remove the cap screws that fasten the rear legs to the overhead guard. See Figure 8. The overhead guard will be removed with the mast assembly.



CAUTION

Do NOT move the control button for the reach, retract, tilt, or sideshift functions. Oil will flow from the hoses for these functions.

3. Operate the LIFT/LOWER control to raise the inner weldment for access to the four cap screws, the shims, and the nutplates that fasten the bottom of the outer weldment to the truck frame. See Figure 10 or Figure 11.
4. Install safety chains to keep the mast components from moving. Remove the cap screws, washers, and clamps that fasten the lift cylinder hoses to the mast weldments. Do NOT disconnect any hydraulic fittings.
5. Remove the safety chains installed in Step 4. Do not damage hydraulic hoses as the mast lowers. Carefully operate the LIFT/LOWER control to lower the inner weldment fully. Make sure that all hydraulic pressure is removed from the system by holding the control in the LOWER position for approximately 5 seconds.
6. Mark the trunnion caps so they can be reassembled in the same position and on the same trunnion from which they are removed. Use chains to connect a crane or other lifting device to the top of the mast assembly. Make sure the chains will not damage the sheaves or other parts of the mast assembly. Make sure the chains and crane have the capacity to lift approximately 2000 kg (4409 lb). Use safety chains to fasten all the mast weldments together so they cannot move. If the reach carriage is installed, install a chain or sling to the reach carriage to keep the mast assembly from tipping during removal. Remove the four cap screws that fasten the trunnion caps.
7. Operate the crane until it gives support to the weight of the mast assembly. Move the crane to a position so that the mast assembly will be lifted vertically. Raise the mast assembly high enough to clear the trunnions. Move the mast assembly approximately 30 cm (1 ft) away from the truck for access to the hoses.
8. Use safety chains to fasten all the mast weldments together so they cannot move. Operate the crane until it gives support to the weight of the mast. Move the crane to a position so that the mast assembly will be lifted vertically. Raise the mast assembly just high enough to clear the trunnions. Move the mast assembly approximately 30 cm (1 ft) away from the truck for access to the hoses. Make sure that the mast assembly AND truck cannot move.
9. Install labels on all plugs and wires for the electrical cable for correct connection during installation. Disconnect the plugs and wires so that the cable is completely disconnected from the truck. The plugs are near the cable tension device inside the electrical compartment above the battery.
10. Move the mast assembly away from the truck.
11. If the mast will be disassembled, put the mast on a level floor with the overhead guard on the bottom as a support. Install a support under the other end. Make sure the mast is level. Keep the safety chains that were installed in Step 6 on the mast assembly.
12. If the mast will NOT be disassembled, put the mast on a level floor with the overhead guard on top.

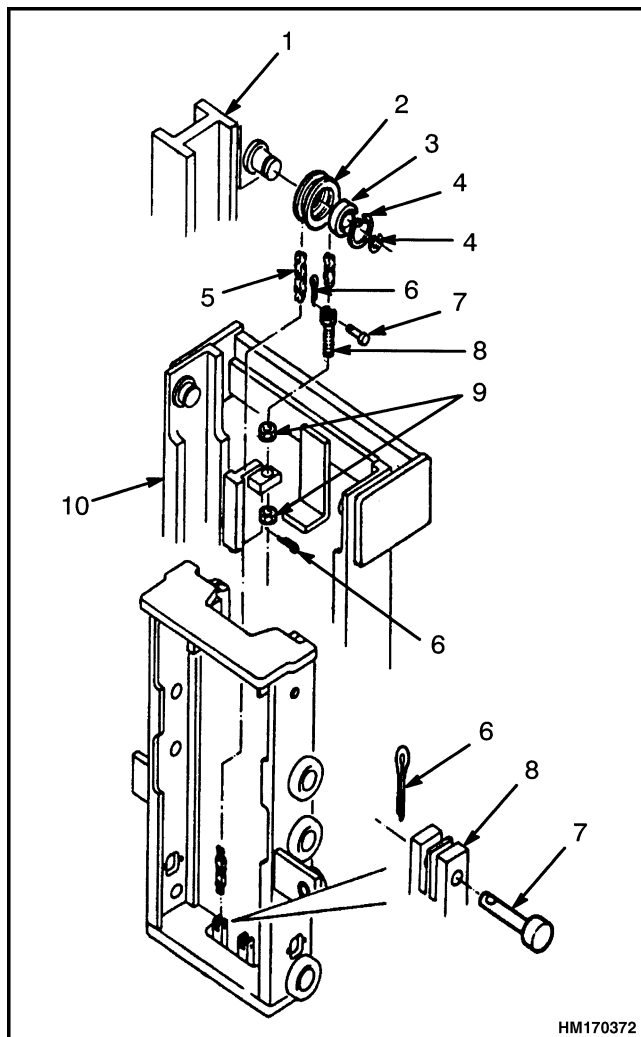

NOTE: REACH CARRIAGE SHOWN. CHAIN ANCHOR ON STANDARD CARRIAGE SIMILAR.

- | | |
|-------------------|--------------------|
| 1. INNER WELDMENT | 7. PIN |
| 2. CHAIN SHEAVE | 8. CHAIN ANCHOR |
| 3. BEARING | 9. ADJUSTMENT NUTS |
| 4. SNAP RING | 10. OUTER WELDMENT |
| 5. LIFT CHAIN | |
| 6. COTTER PIN | |

Figure 16. Removing Chain Sheave



WARNING

Keep control of the lift chains when disconnecting them from the chain anchor. This procedure will

prevent the lift chains from falling and causing an injury or damage.

3. Remove the cotter pin from the pin that fastens the lift chain to the chain anchor near the top of the outer weldment. Remove the anchor pins.
4. Put the lift chains over the carriage.



WARNING

Be careful when removing or installing snap rings. These snap rings are large and can come loose during removal or installation with enough force to cause an injury. Always use the correct snap ring pliers and wear eye and face protection during removal or installation.

5. Remove the snap ring from the sheave mounting stud.
6. Use a prybar to remove the sheave from the stud.
7. Remove the internal snap ring from the chain sheave.
8. Inspect all parts for wear or damage. Replace any worn or damaged parts.
9. If necessary, use a press to remove and install new ball bearings in the sheaves for the lift chains.
10. Reverse the procedure to install the chain sheaves.
11. Operate the truck and test for correct operation of the chain sheave.

LOAD ROLLERS AND WEAR PLUGS, REMOVE AND INSTALL

Read and follow the Safety Procedures When Working Near Mast, as well as all WARNINGS and CAUTIONS.

1. Remove the mast assembly as described in Remove. Remove the lift cylinders as described in Lift Cylinders, Remove and Install Dual-Lift Cylinders. See Figure 4, Figure 5, and Figure 17. Remove the chain sheaves as described in Two-Stage Chain Sheave, Remove and Install. The mast assembly must be horizontal with the carriage side on top.

Legend for Figure 21

- A. REACH OR SIDESHIFT CARRIAGE ONLY
- B. REAR VIEW
- C. FRONT VIEW

- | | |
|--|---|
| <ul style="list-style-type: none"> 1. HOSE BRACKET 2. HOSE BRACKET 3. TO FLOW REGULATOR 4. TO FREE-LIFT CYLINDER 5. TENSION DEVICE 6. CARRIAGE HOSE TO MANIFOLD BLOCK (EACH SIDE OF WELDMENT) 7. HOSE BRACKET (EACH SIDE OF WELDMENT) 8. TO REACH CARRIAGE 9. ELECTRICAL CABLE FOR REACH CARRIAGE | <ul style="list-style-type: none"> 10. TO LIFT TRUCK 11. HYDRAULIC HOSE (LIFT) 12. LIFT TRUCK FRAME 13. HOSE TO RIGHT MAIN CYLINDER 14. TUBE TO LEFT MAIN CYLINDER 15. FLOW REGULATOR HOUSING 16. REGULATOR MOUNT PLATE 17. MAIN LIFT CYLINDERS 18. OUTER WELDMENT |
|--|---|

Free-Lift Hose Sheave**WARNING**

The mast weldments can move and cause an injury even if the mast assembly has been removed from the lift truck. Make sure the mast assembly is level to prevent the components from moving without being moved. Use safety chains to prevent movement after components are in the correct position.

Remove the sheave for the hose to the free-lift cylinder as follows:

1. Fully retract the forks if the reach carriage is installed. Move the key to the **OFF** position. Disconnect the battery and put a tag or lock on the battery connector. Install safety chains between the tops of the inner and outer carriage weldments of the reach carriage to prevent carriage operation.
2. Operate the LIFT/LOWER control to raise the inner weldment. Use safety chains to fasten the carriage and inner weldment so that they cannot move and so that the bottom of the inner weldment is approximately 60 cm (2 ft) off the floor.
3. Lower the carriage so the safety chains are the support for the carriage and inner weldment. The lift hose for the free-lift cylinder must not have tension.
4. Remove the snap ring, washer, free-lift hose sheave, and spacer at the bottom of the intermediate weldment. See Figure 20.
5. Follow the reverse procedure to install the hose sheave for the free-lift cylinder.

Carriage Sheaves

Remove the sheaves for the hoses and cable to the carriage as follows:

1. Fully lower the carriage. Fully retract the forks if the reach carriage is installed. Install safety chains between the tops of the inner and outer carriage weldments of the reach carriage to prevent carriage operation.
2. Make sure that the system does not have hydraulic pressure. Hold the control (for each function) in the **FORWARD** position for approximately 5 seconds to release the pressure. Make sure the hydraulic pump does NOT operate. Move the key to the **OFF** position. Disconnect the battery and put a tag or lock on the battery connector.
3. Fasten the carriage hoses and electrical cable, if installed, to the top of the sheave support at the free-lift cylinder. Disconnect or remove the hoses at the carriage. Install caps to prevent dirt from entering the hydraulic system.
4. Install tags on the connectors and wires of the electrical cable at the carriage for correct connection later. Disconnect the electrical cable.
5. Install tags on the hydraulic hoses at the carriage for correct connection later. Disconnect the hoses and install caps to prevent dirt from entering the hydraulic system.
6. Remove the two capscrews and nuts that fasten the two halves of the hose and cable sheave together. See Figure 20. Do not let the sheave halves fall.
7. Carefully remove the capscrews that fasten the hose and cable sheaves at the top of the intermediate weldment. See Figure 20. Do not let any of the parts fall. These capscrews fasten to the stub shafts of the chain sheaves.

the same and the distance (Step 1) is also correct. Tighten the lock nuts.

NOTE: When the chain adjustments are complete, make sure the cotter pin at the bottom of the chain anchor can be installed under the adjustment nut. If there is no room to install the cotter pin, the chains are too short. Install the correct chains. Make sure the lock nuts on the chain anchors are tight against the mount plate. If there are not enough threads on the chain anchor for correct adjustment, new chains are too long or old chains are too worn. Links can be removed from old chains if the chains are less than 3 percent longer than the correct new chain. Replace old chains that are too long or new chains that are not the correct length.

6. Tighten the chain anchor jam nuts.
7. Check the mast operation as described in Mast Operation Check.
8. Install the mast operator guard if removed.

Three-Stage

1. Adjust the main-lift chains for equal tension.
2. Check chain tension by pushing on both main-lift chains at the same time. If the tension is not the same, remove the mast operator guard if installed. See Figure 8. Loosen both lock nuts at the chain anchors to make any adjustments.
3. Adjust the nuts on the chain anchors until the tension is the same. Tighten the lock nuts.
4. Check the mast operation as described in Mast Operation Check.
5. Install the mast operator guard (if removed).

ADJUST WEAR STRIPS

NOTE: The wear plugs and lift chains must be adjusted before the wear strips are checked for wear, replaced, and adjusted.

The wear strips and shims are fastened to the lower guide blocks of weldments that move. See Figure 27. The wear strips and shims are adjusted:

- For minimum clearance to prevent too much side movement of the weldments.
- To keep the weldments parallel.

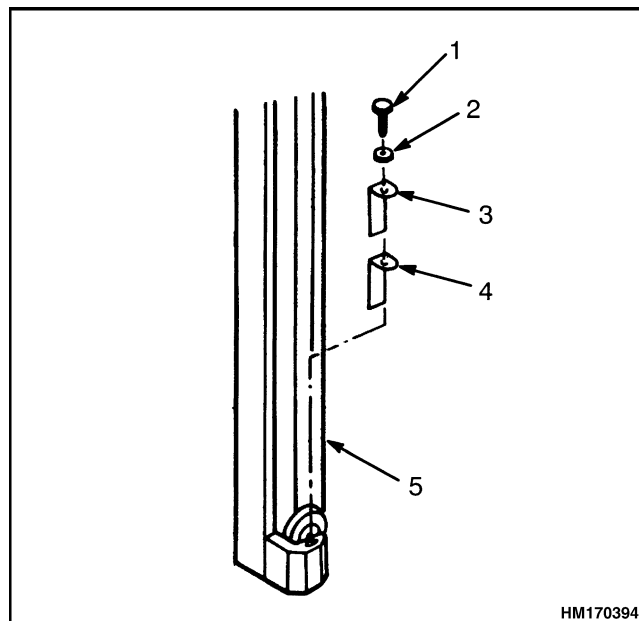

NOTE: WEAR STRIPS AND SHIMS ON THE THREE-STAGE INNER WELDMENT CAN BE USED ON EITHER SIDE. THERE ARE RIGHT AND LEFT WEAR STRIPS AND SHIMS ON TWO-STAGE INNER AND THE THREE-STAGE INTERMEDIATE WELDMENTS.

- | | |
|---------------|---------------------|
| 1. CAPSCREW | 4. SHIM |
| 2. WASHER | 5. WELDMENT CHANNEL |
| 3. WEAR STRIP | |

Figure 27. Typical Wear Strip Assembly

NOTE: Wear strips and shims on the three-stage inner weldment can be used on either side. There are right and left wear strips and shims on the two-stage inner and the three-stage intermediate weldments. See Figure 10 and Figure 27.

Check and adjust the wear strips as follows:

1. If installed, remove the mast operator guard. See Figure 8. Raise the carriage for access to the wear strips. Install safety chains as described in Safety Procedures When Working Near Mast.
2. Remove the capscrews, washers, wear strips, and shims. Replace all worn or damaged parts. One wear strip and one shim on each side is usually the correct adjustment. There must be the same number of shims under the wear strip on both sides of the weldment. Equal shims will keep the weldment parallel with equal clearance.

HFK400 Master Drive Unit

GENERAL



CAUTION

Some of the hardware used on the MDU and traction motor is metric. Use the correct tool to avoid damage.

The HFK400 is used on the NDR030AE, NR035/040/045AE, NS040AF, NS050AF, NDR030CB, NR045CB, NDR030GB, NR045GB, OS030EC, and OS/SS030BE models.

This manual has a description and the repair and adjustment procedures for the parts of the master drive unit (MDU) used on the narrow aisle and grocery reach series of lift trucks. The traction motor, steering, and brake repair procedures are in separate manuals.

DESCRIPTION

The main component parts of the MDU are the case, the motor pinion and large gear set, the pinion and spiral bevel gear set, the bearings, and the axle and wheel. See Figure 1. The traction motor fastens to an adapter ring fastened to the MDU. This adapter ring is part of the large ball bearing and allows the MDU to turn on the axis of the traction motor for steering. The traction motor does not turn with the MDU.

Six capscrews fasten the large ball bearing and MDU to the articulating axle. There is a small pinion gear on the traction motor armature shaft. This gear turns a large gear on the pinion shaft in the MDU. The pinion shaft turns a spiral bevel gear on the axle to turn the drive wheel. The brake is fastened to the other end of the traction motor shaft and provides friction for braking to stop rotation of the shaft. The braking action works through the gears to stop the unit.

DRIVE UNIT MAINTENANCE AND REPAIR

Remove



WARNING

The lift truck and components are heavy. Be sure that all lifting devices (hoists, cables, chains, slings, etc.) are suitable and of adequate capacity to lift the lift truck or component. The lift truck can weigh up to approximately 3541 kg (7800 lb) empty.

1. Move the steering control so the drive wheel is in a position for straight travel.

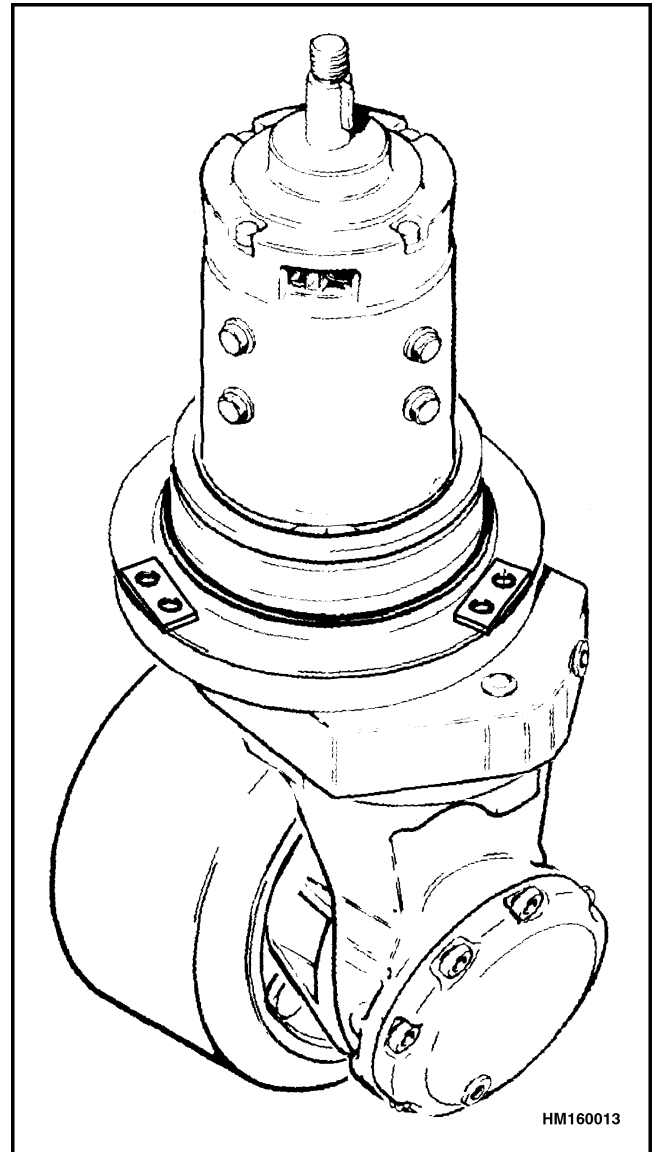

Figure 1. Master Drive Unit With Motor and Wheel







WARNING

Disconnect the battery and separate the connector before opening the drive unit compartment door and before inspecting or repairing the electrical system. If a tool causes a short circuit, the high-current flow from the battery can cause injury or parts damage.

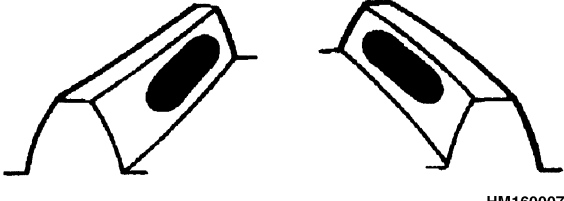
2. Disconnect and remove the battery. Use the battery removal procedure described in either the **Operating Manual** or **Periodic Maintenance** 8000 YRM 970.

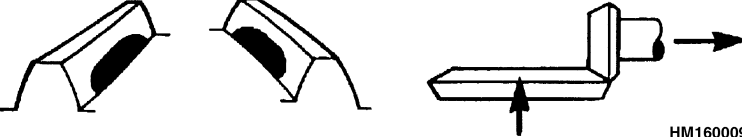
Table 1. Tooth Contact Pattern

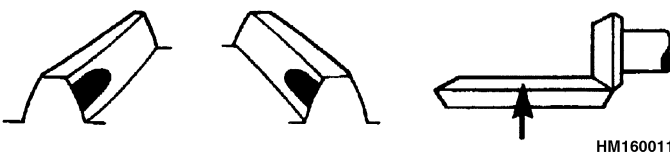
<p style="text-align: center;">Correct Contact Pattern</p>  <p style="text-align: right;">HM160007</p>	<p>Step 1. Apply a colored dye or grease to approximately 12 of the teeth of the spiral bevel gear.</p> <p>Step 2. Apply a small friction load to the edge of the gear so that the gear does not turn easily. Rotate the gear one revolution by turning the large gear on the spiral bevel pinion.</p> <p>Step 3. Check the tooth contact pattern on the spiral bevel gear. Make sure that the pattern is checked on the side of the tooth where the pinion teeth apply the force.</p>
Wrong Tooth Contact Pattern	
<p style="text-align: center;">Tip Contact</p>  <p style="text-align: right;">HM160008</p>	<p>The spiral bevel pinion is too far from the center of the spiral bevel gear. Some movement in the direction of the arrows can be necessary. Adjust the thickness of the shim as described in the assembly procedure.</p>
<p style="text-align: center;">Base Contact</p>  <p style="text-align: right;">HM160009</p>	<p>The spiral bevel pinion is too close to the center of the spiral bevel gear. Some movement in the direction of the arrows can be necessary. Adjust the thickness of the shim sets as described in the assembly procedure.</p>
<p style="text-align: center;">Inner Contact</p>  <p style="text-align: right;">HM160010</p>	<p>The spiral bevel pinion is too far from the center of the spiral bevel pinion. Some movement of the spiral gear away from the spiral bevel pinion can be necessary. Adjust the shim sets at the spiral bevel gear as described in the assembly procedure.</p>
<p style="text-align: center;">Outer Contact</p>  <p style="text-align: right;">HM160011</p>	<p>The spiral bevel pinion is too far from the center of the spiral bevel pinion. Some movement of the spiral gear toward the spiral bevel pinion can be necessary. Adjust the shim sets at the spiral bevel gear as described in the assembly procedure.</p>

33. Adjust the dial indicator to zero. Turn the wheel shaft in both directions to measure any deflection. The admissible range for backlash is between 0.03 to 0.11 mm (0.0012 to 0.0043 in.). If the backlash needs to be adjusted at this point, the total thickness of the outer plus the inner shims must remain constant (i.e., if you remove a shim from beneath the inner bearing cup, you must add it to the shims beneath outer bearing cup). The ideal backlash is 0.07 mm (0.003 in.).

34. After the proper backlash and preload have been obtained, remove the bevel gear and wheel shaft in order to mount the thread-protective shield and the radial shaft seal.

35. Thoroughly clean the seat of the thread-protective shield on the housing with Loctite Fast Cleaner 706 or equivalent.

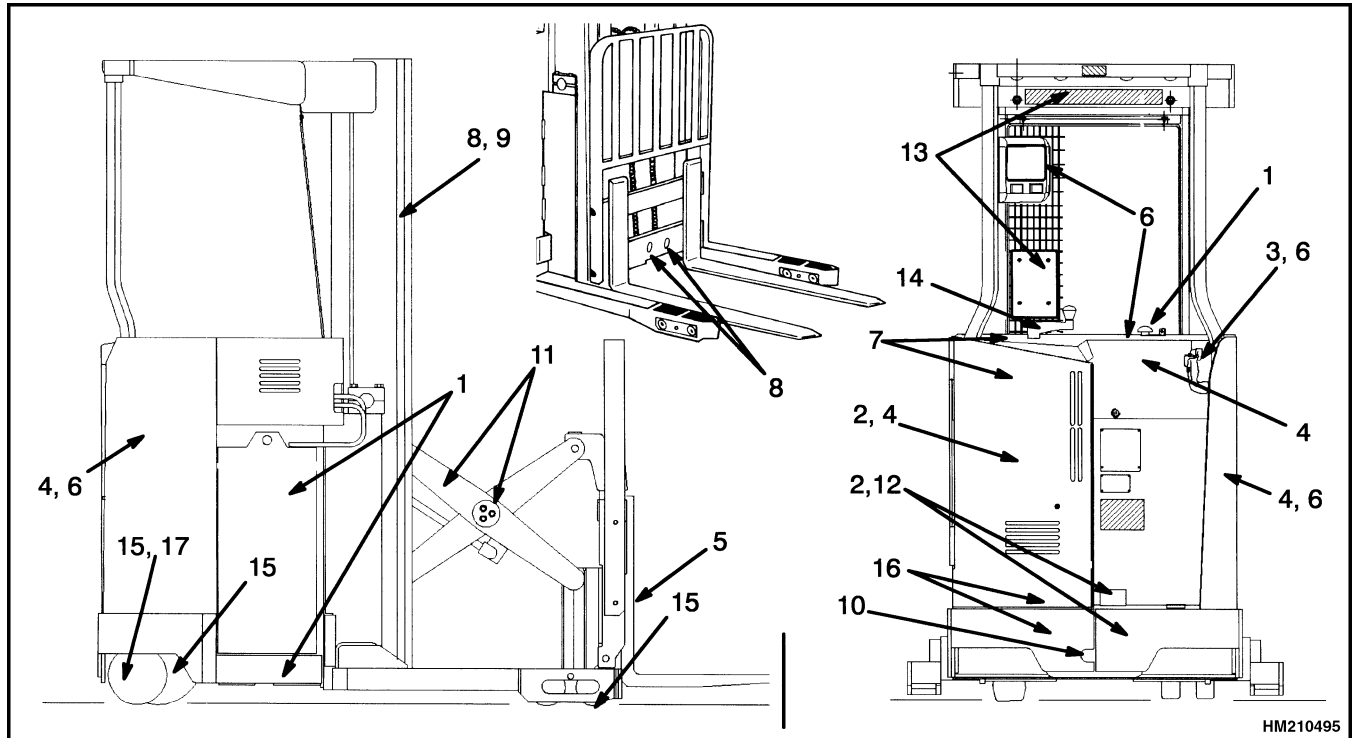

Figure 3. Maintenance Points

Table 1. Maintenance Schedule

Item No.	Item	8 hr/ 1 day ⁴	350 hr/ 2 mo ⁴	2000 hr/ 1 yr ⁴	Procedure or Quantity	Specification
1	Battery Restraint Panels Power Disconnect	X X X		⁵	Check Level Check Condition Check Operation	See Specifications
2	Brake Fluid Rods and Drum Splines Master Cylinder	X	X L	C	Check Operation 0.45 liter (0.12 gal) As Required Drain, Flush, Fill	SAE J-1703 Brake Fluid Antiseize Lubricant ³ SAE J-1703 Brake Fluid
3	Control Handle	X			Check Operation	
4	Electrical Circuits Contactors Motor Brushes	X	X X		Check Operation Check Condition Check Condition	
5	Forks-All Hook Fork Guides and Locks	X X	L		Check for Damage As Required	Antiseize Lubricant ³

X=Check C=Change L=Lubricate

¹ Hydraulic Oil

² Chevron EP Hydraulic Oil 68 or equivalent

³ Antiseize Lubricant

⁴ Whichever comes first

⁵ Equalization Charge approximately each month but not more than each week

⁶ Multipurpose Grease with 2-4% Molybdenum Disulfide for normal operations

⁷ Change after 150 to 500 hours. No subsequent change for life of unit

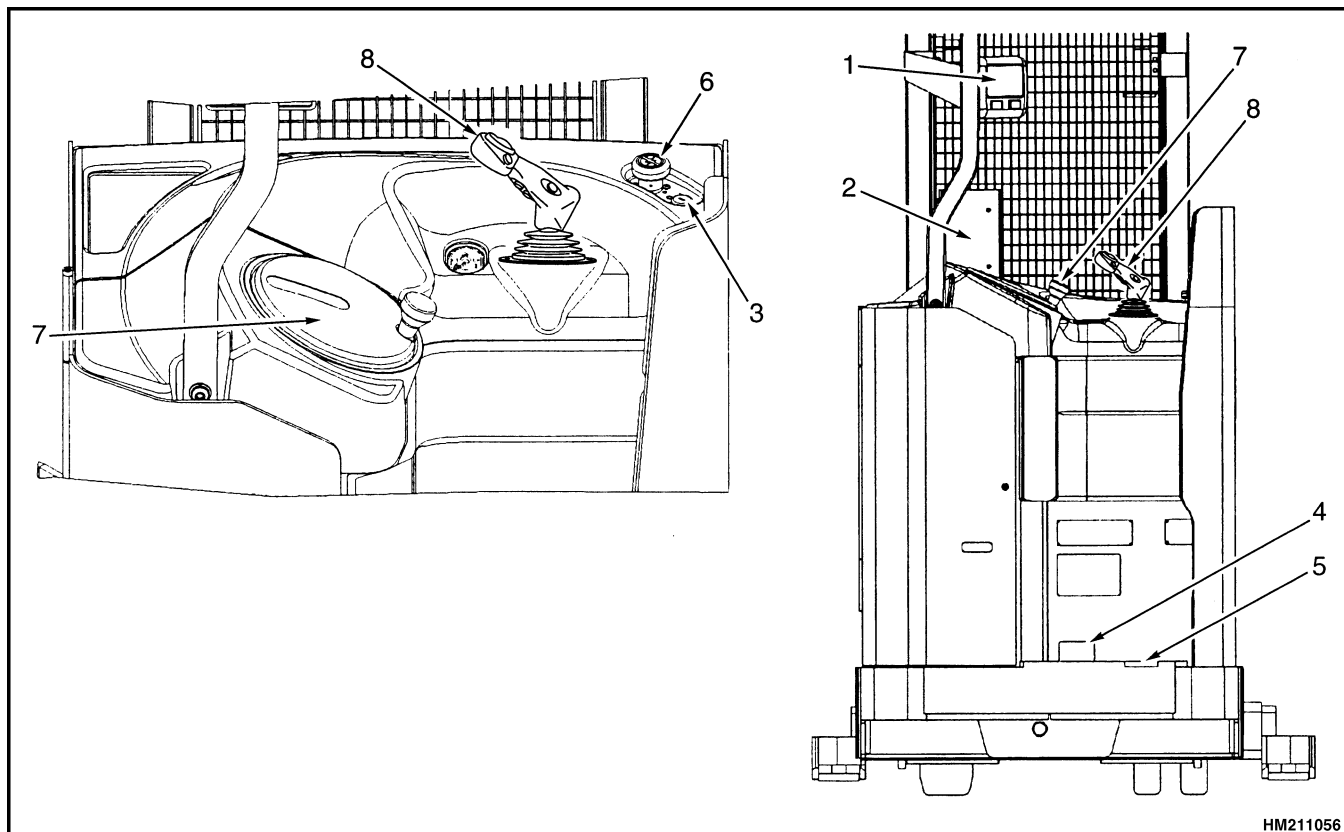

HM211056

1. INSTRUMENT DISPLAY
2. OPERATOR MANUAL
3. KEY SWITCH
4. BRAKE PEDAL

5. OPERATOR SENSING SWITCH
6. BATTERY POWER DISCONNECT
7. STEERING DISK
8. MULTIFUNCTION CONTROL HANDLE

Figure 11. Operating Controls

The dash display is powered even when the vehicle is not being operated. When the battery is disconnected, the dashboard contains an internal backup battery, capable of memory retention of the battery indicator and hourmeter.

The **message center** is a 16-character, dot matrix LCD (Liquid Crystal Display) with a green backlighting. The 16-character, alphanumeric display shows the hourmeter readings, lift truck performance status, and warning or fault codes in English. When a warning message is received, the warning/fault indicator will blink as a yellow light. When a fault message is received, the warning/fault indicator will blink as a red light.

The **function selection lights** display the selected hydraulic function. Status messages will be displayed for LIFT, REACH, TILT, and SIDESHIFT. The function selection lights will display the current hydraulic function, independent of the present LCD display.

The **battery indicator** has a 10-bar multicolor LED (Light Emitting Diode) to indicate battery charge status. The bars are green, yellow, and red. As battery power is used, the LED light bar turns off; first green, then yellow, then red. The next-to-bottom red bar will flash, indicating a nearly discharged battery. At empty, the bottom red bar will alternately flash with the LO-BATT indicator LED (a crossed battery symbol). The lift function for the lift truck will be locked out at this point. Continued operation with a discharged battery can damage the battery, motors, or the contactors.

The **drive mode display** allows the operator to select the level of lift truck performance most suited to the application. Operation of the drive mode switch will cause the green indicator and corresponding drive mode to increase from Turtle to Mid to Rabbit. A solid green light is used to indicate the current drive mode. Mode changes only occur when the direction handle is in the neutral position. If the drive mode switch is pressed while traveling, a blinking green light will illuminate next to the

Battery Maintenance

HOW TO CHARGE BATTERY



WARNING

If the lift truck was operated with a low battery, check all contactors for welded contacts before a charged battery is connected.

Make sure the key switch is OFF and the park brake is set before connecting the battery.

The acid in the electrolyte can cause injury. Use water to flush the area and make the acid neutral with a water and soda solution. Acid in the eyes must be flushed with water. Batteries generate explosive fumes when they are being charged. Keep fire, sparks, and burning material away from the battery charger area. Avoid sparks from the battery connections. Charge batteries only in the special area for charging batteries. When the battery is being charged, keep the vent caps clear. The battery charger area must have ventilation so that explosive fumes are removed. Open the battery cover on a covered battery. Disconnect the battery when doing cleaning and maintenance.



CAUTION

Never connect the battery charger plug to the plug of the lift truck. You can damage the electronic controller. Make sure the battery charger voltage is the correct voltage for the battery.

NOTE: Use only battery chargers approved by the battery manufacturer or dealer.

Correct use of the hydrometer and proper operation of the battery charger is important. See Figure 17. Follow the instructions of the charger manufacturer. Never let the battery discharge below the minimum value given by the battery manufacturer. A fully charged battery will have a specific gravity of 1.265 to 1.310 at 25°C (77°F). Never charge a battery at a rate that will raise the electrolyte temperature above 49°C (120°F). Never let a battery stay discharged for long periods.

NORMAL CHARGE: This charge is the charge that is normally given to a battery that is discharged from normal service. Many users give this charge at a regular interval based on usage. This practice will keep the battery fully charged if the battery is not discharged below the limit. Always use a hydrometer to check the battery if the interval charge cycle is used. Frequent charging

of a battery that has a 2/3 or more charge can decrease battery life.

EQUALIZING CHARGE: This charge is at a low rate and balances the charge in all of the cells. The equalizing charge is normally given approximately once a month. It is a charge at a slow rate for 3 to 6 hours in addition to the regular charging cycle.

Do NOT give an equalizing charge more than once a week. The most accurate specific gravity measurements for a charged battery will be after an equalizing charge. If the specific gravity difference is more than 0.020 between cells of the battery after an equalizing charge, there can be a defective cell. Consult your battery dealer.

Also see the section the **Industrial Battery 2240 YRM 1** for additional information on the charging and maintenance of a battery.

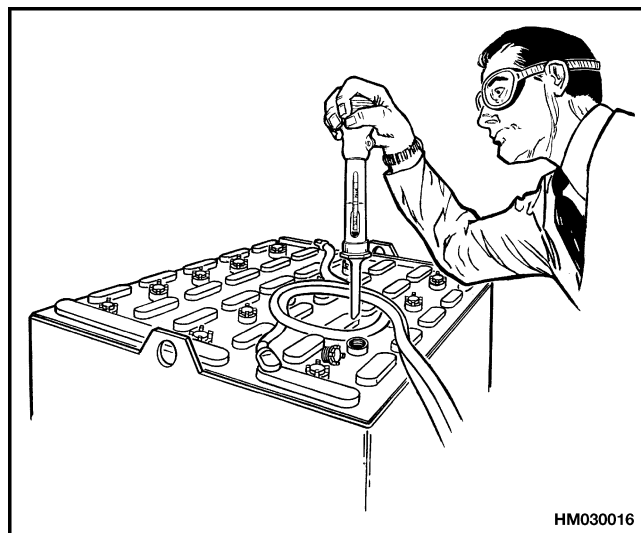

HM030016

Specific Gravity Reading	Electrolyte Temp.	Correction Points	Correct Value
1.210	31°C (88°F)	+0.003	1.213
1.210	27°C (81°F)	+0.001	1.211
1.210	25°C (77°F)	0.000	1.210
1.210	18°C (64°F)	-0.004	1.206

±0.001 for each 2°C from the 25° base value.

Figure 17. Battery Check

Legend for Figure 2

- | | |
|----------------------------|-------------------------|
| 1. COVER PLATE | 20. EXTERNAL SNAP RING |
| 2. VALVE ASSEMBLY | 21. FRONT PIVOT PINS |
| 3. 6x4 FITTING WITH O-RING | 22. WASHER |
| 4. 4x4 FITTING WITH O-RING | 23. LOCKWASHER |
| 5. LOCKWASHER | 24. CAPSCREW |
| 6. BOLT | 25. LOCKWASHER |
| 7. 6x4 FITTING WITH O-RING | 26. FITTING WITH O-RING |
| 8. HOSE ASSEMBLY | 27. RETAINING PLATE |
| 9. HOSE ASSEMBLY | 28. LOCKWASHER |
| 10. HOSE ASSEMBLY | 29. CAPSCREW |
| 11. HOSE ASSEMBLY | 30. WELDMENT |
| 12. HOSE ASSEMBLY | 31. STOP ASSEMBLY |
| 13. HOSE ASSEMBLY | 32. STOP PAD |
| 14. HOSE ASSEMBLY | 33. WASHER |
| 15. HOSE ASSEMBLY | 34. LOCKWASHER |
| 16. WIRE CLAMP | 35. CAPSCREW |
| 17. CAPSCREW | 36. CAPSCREW |
| 18. WIRE ASSEMBLY | 37. WIRE TIE |
| 19. SHEAVE | |

Repair - General

NOTE: Most repairs of the reach carriage can be done without removing the carriage from the mast. These repair procedures require that the carriage is installed in the mast and the scissor arms are fully extended.

**WARNING**

The reach carriage can fall or tip easily and cause an injury when not installed in the mast. If the reach carriage cannot be installed in a mast during repair, make sure the inner frame is fastened to a support that cannot move. The inner frame must be in the same position as it is in the mast. The inner frame must also be fastened so that it cannot move on the support. The support must be strong enough to allow full extension of the reach carriage without tipping.

**WARNING**

Hydraulic oil is hot after system operation and can cause burns. Do not disconnect any hydraulic lines of the system until the oil for the system is cool.

**CAUTION**

Make sure the lift truck is in a location that is level and has access to a crane or other lifting device before doing any repairs on the reach carriage.

NOTE: It is usually not necessary to completely disassemble the reach carriage. Do only the steps of the procedures necessary to make the required repairs.

Read and follow the Safety Procedures When Working Near Mast in the section **Mast Repair** 4000 YRM 482, as well as all **WARNINGS** and **CAUTIONS**.

Load Backrest Removal and Installation**WARNING**

The load backrest is heavy and can cause an injury. Do not try to remove it without using a lifting device.

1. Use a hoist to secure the load backrest in position.
2. Loosen the four capscrews that fasten the load backrest to the carriage assembly.

3. Lift the load backrest off the mobile frame.
4. Reverse the procedure to install the load backrest. Tighten the capscrews to 102 N•m (75 lbf ft).

**WARNING**

The outer frame is heavy and can cause an injury during installation. NEVER put any part of your body between the outer frame and the scissor arm assembly. Tipping is even more possible if the forks are installed. Make sure to install the chains or slings between the crane and outer frame to prevent tipping.

1. Use a crane as a support for the outer frame. Move the outer frame into the approximate position for installation on the scissor arm assembly.

**CAUTION**

Do not let the load bearings or shims fall off the scissor arms.

2. Make sure the shims and load bearings are installed in the correct positions on the scissor arms. If necessary, use tape to keep the load bearings on the scissor arms. Do not let the load bearings fall during installation of the outer frame.

NOTE: Correct placement of shims is critical for the operation of the reach mechanism. Unless the shims are installed correctly, the reach mechanism will not operate.

**WARNING**

There are pinch points on the reach carriage that can cause an injury. Use clamps and blocks to prevent the scissor arms from moving. Install the clamps and blocks at the channels of the inner frame to make sure that the load bearings cannot move in the channel. See Figure 7.

**CAUTION**

Do NOT operate any functions if the outer frame has been removed. Hydraulic oil can come out of the hoses.

NOTE: Another installation method for the outer frame is to raise the scissor arms and inner frame as a unit. Operate the lift system of the lift truck to raise the scissor arms and inner frame above the outer frame. Use the crane and a bar to align the channels of the outer frame under the load bearings of the scissor arms. Tilt the outer frame forward for clearance. Have another person slowly lower the scissor assembly so the load bearings

are in the channels. Tilt the outer frame to align the scissor arms for installation of the pins and retaining brackets.

NOTE: Use safety chains on the inner frame and mast weldments to keep the inner frame and mast weldments from moving. Install the safety chains as described in Safety Procedures When Working Near Mast in this section.

3. Use the crane to move the outer frame for alignment with the scissor arms. Tip the outer frame forward and align the channels with the load bearings of the scissor arms. Slowly lift the outer frame to install the load bearings in the channels.

NOTE: Another removal method for the outer frame is to raise the scissor arms and inner frame as a unit. All auxiliary hoses must be plugged to do this. Remove the safety chains and operate the lift system of the lift truck to raise the scissor arms and inner frame off the outer frame.

4. The load bearings must move in the channels and have minimum clearance with free movement. Keep the outer frame in vertical alignment and move it up and down on the load bearings. If necessary, add or remove shims for free movement and minimum clearance.
5. Install new bushings in the top end of each scissor arm. Lubricate the bushings with multipurpose grease. Tip the outer frame back and align the holes for the pivot pins with the bushings in the top scissor arms.
6. Keep the pivot pins (8, Figure 8 and Figure 9) in alignment to install the retaining brackets and hardware. Install the pins and brackets.
7. Install the hoses and wire at the base of the inner frame as marked during removal. For units without sideshift, see Figure 8. For units with sideshift, see Figure 9.
8. After all hydraulic lines and wire are connected, operate the functions to check for leaks and correct operation. Remove the air from the system as described in Carriage or Reach Assembly Adjustments. Install new cable ties at the original locations for clearance of hoses and electrical cables during operation.

**CAUTION**

Do not damage lift chains, hoses, or electrical cables as the carriage assembly is lifted out of the mast weldment.

- Carefully lift the reach assembly or inner frame assembly out of the rear weldment. Carefully lower the reach assembly or inner frame assembly to the floor.

**WARNING**

Make sure that the reach assembly is stable and cannot fall to cause an injury. Make sure the safety chains are still installed (Step 1). If the forks are removed, put the reach assembly (or inner frame assembly) on the floor so that the mast side is on top.

- The side rollers must be adjusted while the reach assembly is out of the mast channels. Adjust the side rollers as described in Adjust Side Rollers, Carriage or Reach Assembly Adjustments.

DISASSEMBLE

NOTE: It is usually not necessary to remove all the parts of the inner frame assembly. Remove only the necessary parts to do the repair. The thrust rollers are removed during removal of the inner frame assembly.

- If necessary, remove the reach cylinders. See Reach Cylinders.
- Remove the jam nuts and setscrews for the wear plugs.
- If necessary, replace the wear plugs by pushing at the back of the wear plug. See Figure 13.

**WARNING**

Be careful when removing or installing snap rings. These snap rings are large and can come loose during removal or installation with enough force to cause an injury. Always use the correct snap ring pliers, and wear eye and face protection during removal or installation.

- Remove the snap rings from the stub shaft for the load roller.
 - Use a prybar to remove the load roller from the stub shaft for the load roller. See Figure 14.
 - Remove the capscrews that fasten the side roller brackets. Remove the side rollers and shim sets. Install labels for correct installation of the shim sets in the same positions. When the new side rollers are installed, the shim arrangement will normally be the same or similar.
- NOTE:** Correct placement of shims is critical for the operation of the reach mechanism. Unless the shims are installed correctly, the reach mechanism will not operate.
- If necessary, remove the hydraulic lines and hoses at the base of the inner frame.

CLEAN AND INSPECT**CAUTION**

Do NOT use steam to clean the load bearings. Do not use compressed air on the bearings. The bearings are sealed and permanently lubricated. The air can force the lubricant out of the bearings.

Clean all of the parts of the inner frame with solvent. Dry the parts with compressed air. Inspect the parts of the inner frame for damage and wear. Inspect all rollers for cracks, flat spots, or bearings that do not turn freely. Replace any roller that shows wear or is damaged.

ASSEMBLE**WARNING**

The inner frame assembly is heavy and can cause an injury if it tips or falls. Make sure the inner frame assembly is stable before installing any parts.

NOTE: If the scissor arms are not installed, install the inner frame in the mast before installing the scissor arm assembly.

See Install.

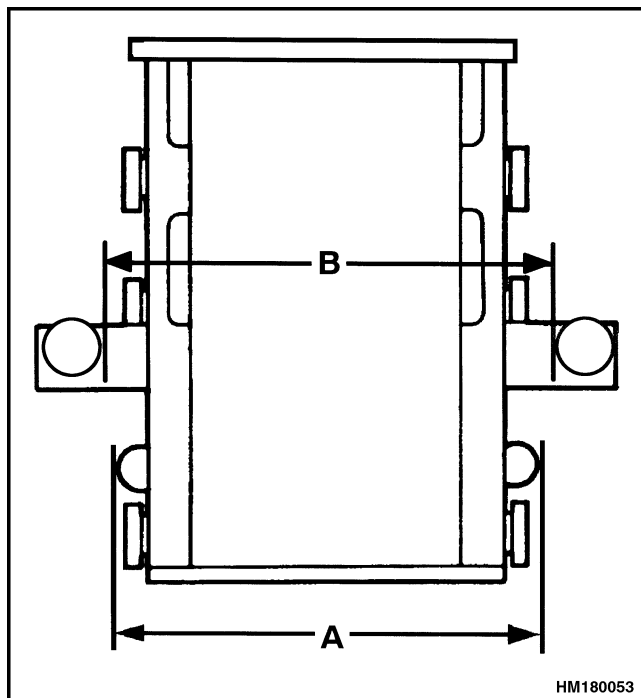

Figure 19. Reach Assembly Side and Thrust Roller Widths

3. If the distance **B** is more than 4 mm (0.16 in.) less than the maximum measurement of Step 1, install smaller size thrust rollers. If the distance **B** is more than 4 mm (0.16 in.) greater than the maximum measurement of Step 1, install larger size thrust rollers. Install the same size rollers on each side for a minimum clearance at the maximum measurement point (Step 1). Thrust rollers have outside diameters of 74, 76, or 78 mm (2.88, 2.96, or 3.04 in.).

ADJUST REACH CYLINDERS

NOTE: The reach cylinders must be adjusted if either reach cylinder has been replaced or the rod ends have been removed. Adjustment is also necessary if major parts of the reach mechanism have been replaced.

The reach mechanism must be adjusted so the outer frame or sidershifter assembly just touches the stops on the inner frame with the cylinders fully retracted. The mechanism must also extend the correct distance.

WARNING

The points between the scissor arms and the inner frame, outer frame are pinch points and can cause an injury. Do NOT put any part of your body between these assemblies if they can move. Always

move the key to the OFF position and disconnect the battery.

1. Remove the air from the reach system as described in Carriage or Reach Assembly Adjustments. Operate the reach mechanism to fully extend and retract the forks for several cycles.
2. Fully extend the forks, move the key to the **OFF** position, and disconnect the battery. Measure the distance between the contact surface of the inner frame and the stops on the outer frame. Measure the distance on both sides. The correct distance for a single-reach unit is $610 +3 -6$ mm ($24 +0.12 -0.25$ in.). The correct distance for a double-reach unit is $1067 +3 -6$ mm ($42 +0.12 -0.25$ in.).
3. If the distance is not within specifications on both sides, loosen the capscrews at the rod ends of the reach cylinders. Use a wrench on the wrench flats to rotate the cylinder rods for adjustment. Temporarily tighten the capscrews.
4. Operate the reach mechanism through several cycles and fully extend the forks. Move the key to the **OFF** position and disconnect the battery. Measure the distance on each side again. Both measurements must be within specifications **AND** the measurements must be within 3 mm (0.12 in.) of each other. If the measurements are not within specifications, repeat Step 3 and Step 4 until all measurements are correct. Temporarily tighten the capscrews without moving the rods after all measurements are correct.
5. Fully retract the forks and check each stop on the outer frame. The inner frame must be touching the stop pads.
6. Extend the reach mechanism, move the key to the **OFF** position, and disconnect the battery. Add or remove shims under each stop pad as necessary. Do **NOT** use more than 3/8" shims. Repeat Step 5 and Step 6 until the outer frame touches on both sides.
7. Fully extend the forks, move the key to the **OFF** position, and disconnect the battery. Loosen the capscrews at the rod ends of the reach cylinders. Use a wrench to rotate the cylinder rods 1/4-turn clockwise into the cylinder. This adjustment allows the stop pads to absorb the shock instead of the reach cylinders as the mechanism retracts. Tighten the rod end capscrews to 48 to 54 N•m (35 to 40 lbf ft).

TABLE OF CONTENTS

SEM Traction Motor Controller	1
Description/Features	1
Remove	1
Test.....	2
Install.....	3
Programmer Handset	3
Description/Features	3
SCROLL DISPLAY Keys	3
CHANGE VALUE Keys.....	3
MORE INFO Key	4
Operation	4
Connecting Handset to Traction Motor Controller	4
Disconnecting Handset from Traction Motor Controller	4
Programmer Self Test	5
Operating Modes.....	5
Program Menu	5
Test Menu	6
Diagnostics Menu	6
Diagnostic History.....	6
Special Program Menu	7
Programming the Traction Motor Controller.....	8
Troubleshooting	10
Status LED Diagnostics	10
Programmer Diagnostics.....	11
Diagnostics Menu.....	12
Test Menu.....	22

This section is for the following models:

NDR030GB, NR045GB [B861];
 NDR030AE, NR035/040/045AE [C815];
 NS040AF, NS050AF [C816];
 NDR030CB, NR045CB [D829]

Table 6. SEM Traction Motor Controller Factory Values and Minimum/Maximum Ranges (Continued)

Menu Display	Function Description		Batt. Volts	Factory Value	Min/Max Values Allowed	Units of Measure
M3 MAX SPEED	M3 Speed Limit	NDR030AE, NR035/040/045AE, NS040/050AF	24	100	25 to 100	% of Throttle
		NDR030AE, NR040AE, NS040/050AF	36			
		NDR030CB, NR045CB	36			
M2 MAX SPEED	M2 Speed Limit	NDR030AE, NR035/040/045AE, NS040/050AF	24	100	25 to 100	% of Throttle
		NDR030AE, NR040AE, NS040/050AF	36			
		NDR030CB, NR045CB	36			
M1 MAX SPEED	M1 Speed Limit	NDR030AE, NR035/040/045AE, NS040/050AF	24	65	25 to 65	% of Throttle
		NDR030AE, NR040AE, NS040/050AF	36			
		NDR030CB, NR045CB	36			
M1 = TURTLE M2 = MID M3 = RABBIT						

**WARNING**

The capacitor in the traction motor controller can hold an electrical charge after the battery is disconnected. To prevent electrical shock and injury, discharge the capacitor before inspecting or repairing any component. Wear safety glasses. Make certain the battery has been disconnected. Discharge the capacitors in the controller by connecting a load (such as a contactor coil or a horn) across the controller's B+ and B- terminals. **DO NOT use a screwdriver to discharge the traction motor controller.**

4. Discharge the capacitors in the traction motor controller by connecting a load (such as a contactor coil or a horn) across the controller's B+ and B- terminals.
5. Connect the PROGRAMMER HANDSET to the traction motor controller. Connect the cord of the handset plug into the 4-pin Molex, Mini-Fit Jr. receptacle on the front of the controller.

NOTE: Each time the programmer handset is connected to the controller, it acquires all of the controller function value settings and stores them in its temporary memory. This allows the user to revert back to the original settings at any time. The SPECIAL PROGRAM menu selection RESET ALL SETTINGS is used to

revert to the original settings. Any inadvertent change made to any of the function values can be "undone" in this manner, as long as the programmer has not been unplugged or the key switch turned **OFF** (power disconnected).

6. Reconnect the battery.

NOTE: The brake pedal must be released (up position) during Step 7.

7. Turn the key switch to the **ON** position. Ensure battery disconnect switch is closed.
8. Press the PROGRAM button on the PROGRAMMER HANDSET. The green LED in the corner of the PROGRAM button lights to indicate that the HANDSET has been placed in the PROGRAM mode.
9. Press the SCROLL DISPLAY buttons, as required, until the desired function is shown on the top line of the display.
10. Press the MORE INFO button to display additional information, if desired, on the selected function. The green LED in the corner of the MORE INFO button lights to indicate that the MORE INFO option has been selected.

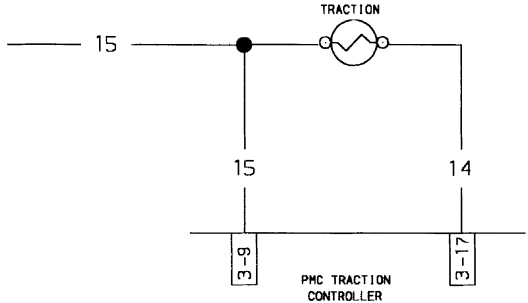
LED Code	Dash Display Message	Programmer Handset Display Message
3, 4	DRIVE CTRL FAULT	MISSING CONTACTOR
<p style="text-align: center;">Condition</p> <p>Handset is plugged into the traction motor controller. Key switch is in the ON position. Diagnostic menu is selected.</p> <p style="text-align: center;">Truck Response</p> <p>Traction is disabled until fault condition is corrected.</p> <p style="text-align: center;">Possible Causes and Test Procedures</p> <ul style="list-style-type: none"> • Traction contactor missing or contactor coil open. Check traction contactor coil for open condition. Contactor coil should measure approximately 17 ±1 ohms. If contactor coil is open, replace it. • Open wire between the traction motor controller and the contactor coil. Check for continuity between pin 17 at the traction motor controller and wire #14 at the contactor coil. Check for continuity between pin 9 at the traction motor controller and wire #15 at the contactor coil. These checks should read near 0 ohms. If they do not, locate the open and repair it. 		<p style="text-align: center;">MISSING CONTACTOR</p>  <p style="text-align: right;">HM080719</p>
		<p style="text-align: center;">Logic</p> <p>Displayed when lower-than-normal current is sensed in the traction controller coil.</p>

STEERING SYSTEM

**NDR030GB, NR045GB [B861];
NDR030AE, NR035/040/045AE [C815];
NS040AF, NS050AF [C816];
NDR030CB, NR045CB [D829]**

correctly. Remove the capscrews and lockwashers retaining the pump to the motor.

Assemble and Install

1. Install a new seal in the motor end housing.
2. Put multipurpose grease on the splines of the pump shaft. Align the pump shaft with the opening in the motor and install the pump on the motor using the two capscrews and lockwashers.
3. Install the mounting bracket on the motor.



WARNING

The motor and pump assembly have a weight of approximately 27 kg (60 lb). The steering pump motor has ceramic permanent magnets. Do not let the motor fall. The magnets can be damaged.

4. Install the steering pump and motor. Use the four capscrews, lockwashers, brackets, and rubber channel mounts to retain the pump and motor assembly.
5. Connect the hydraulic hoses to the fittings as identified during removal.
6. Connect the power cables on the motor.



WARNING

If the hoses are incorrectly connected, the disk will move rapidly with high force when the truck is started. Do not place the hands near the disk when starting the lift truck after connecting the pump.

7. Check the hydraulic level of the hydraulic tank. Test operate the steering pump. Connect the battery. Check for leaks. Install the instrument panel cover. Remove the blocks from both sides of the drive/steer tire, caster wheels, and the load wheels.

1. CAPSCREW
2. O-RING
3. FITTING
4. ELBOW

PUMP

Remove

1. Disconnect the battery. Block the drive tire, caster wheels, and load wheels on both sides to prevent movement of the lift truck.
2. Install labels on the hydraulic lines for proper installation at assembly. Disconnect the hydraulic lines and install caps on the lines and fittings.
3. Remove the two capscrews and lockwashers retaining the steering pump to the motor. Remove the pump from the motor. See Figure 8.

Install

1. Align the splined shaft of the pump with the motor and install the pump.
2. Install the two capscrews and lockwashers to retain the pump to the motor.

Disassemble

1. Disassemble the fittings, elbows, and O-rings from the pump body. See Figure 9.



WARNING

Be careful when removing or installing snap rings. These snap rings can come loose during removal or installation with enough force to cause an injury. Always use the correct snap ring pliers and wear eye and face protection during removal and installation.

2. Use a pair of snap ring pliers and remove the snap ring retaining the shaft seal to the drive gear shaft. Remove the shaft seal.
3. Mark the flange, pump body, and load-sensing valve assembly for orientation during assembly.
4. Remove the four capscrews from the pump body. Separate the mounting flange and the end cover from the pump body. Remove the backup rings, seals, bushings, and O-rings.
5. Remove the idler gear and drive gear.

5. ELBOW
6. ELBOW
7. PUMP

Troubleshooting

PROBLEM	POSSIBLE CAUSE	PROCEDURE OR ACTION
No steering action when the steering wheel is turned.	Low oil level or no oil in hydraulic tank.	Fill tank to correct level.
	Hydraulic hoses or connections are open.	Repair oil lines.
	The sleeve and spool in the control unit will not move.	Repair steering control unit.
The lift truck steers slowly. The steering tiller is difficult to turn.	Low oil level or no oil in hydraulic tank.	Fill tank to correct level.
	The hydraulic pump motor is inoperative.	Repair or replace pump motor.
	Hydraulic lines to the control unit are damaged or have a restriction.	Repair oil lines.
	The sleeve and spool in the control unit are worn.	Repair steering control unit.
	The parts of the metering section are worn.	Repair steering control unit.
	The check valve in the control unit does not open.	Clean or repair steering control unit.
The steering disk turns the drive wheels in the wrong direction.	The relief valve in the manifold block is damaged or not adjusted correctly.	Adjust relief valve or replace the steering control unit.
	Hydraulic hoses at the control unit are not connected correctly.	Connect lines correctly.
The steering continues to turn after the steering wheel stops.	The metering rotor is not aligned correctly.	Check the rotor for correct alignment and repair as required.
	The neutral position springs are broken.	Repair steering control unit.
	The spool or sleeve is damaged.	Repair steering control unit.

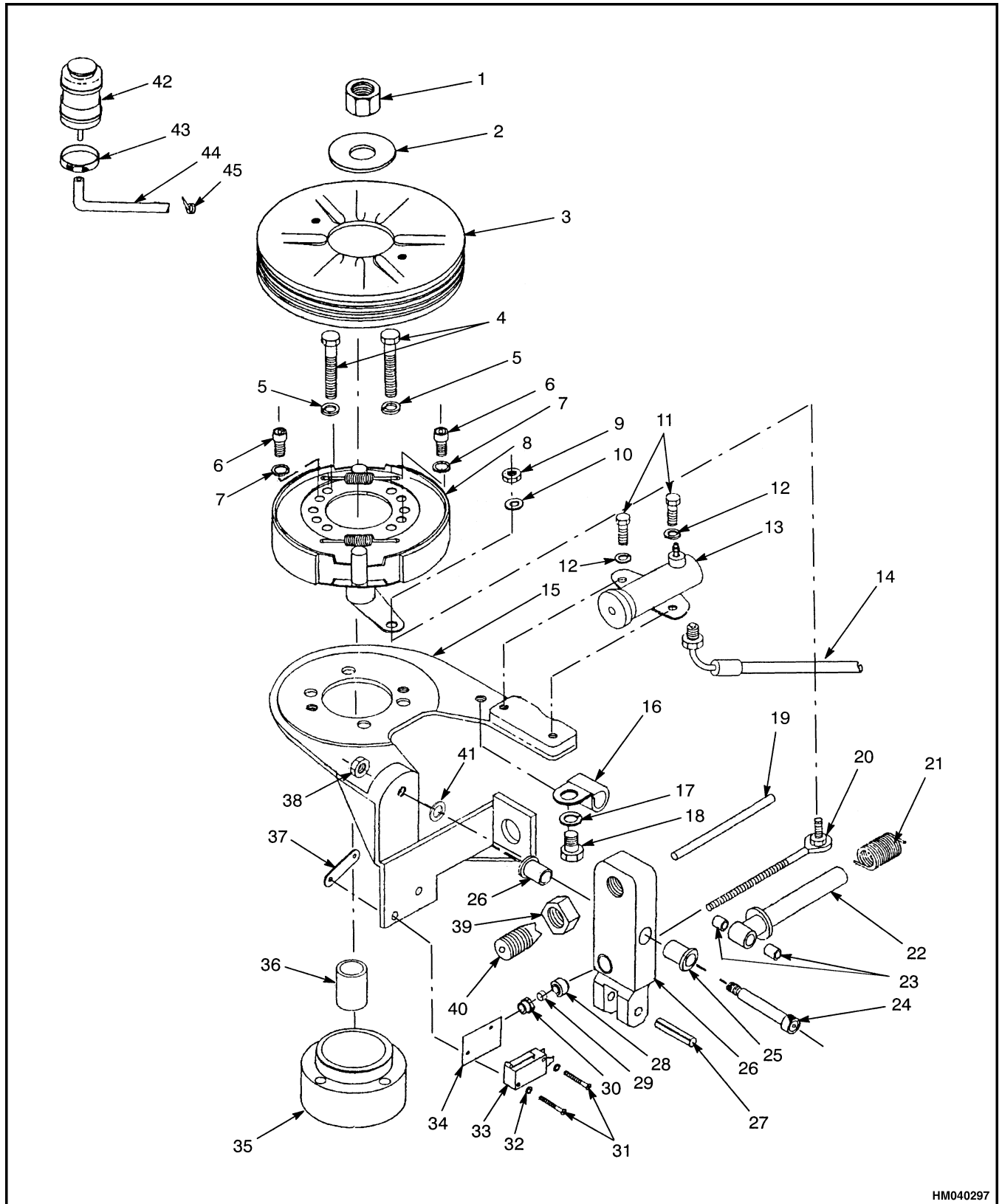

HM040297

Figure 2. Brake Assembly

CLICK HERE TO **DOWNLOAD** THE COMPLETE MANUAL

- Thank you very much for reading the preview of the manual.
- You can download the complete manual from: www.heydownloads.com by clicking the link below



- Please note: If there is no response to CLICKING the link, please download this PDF first and then click on it.

CLICK HERE TO **DOWNLOAD** THE COMPLETE MANUAL