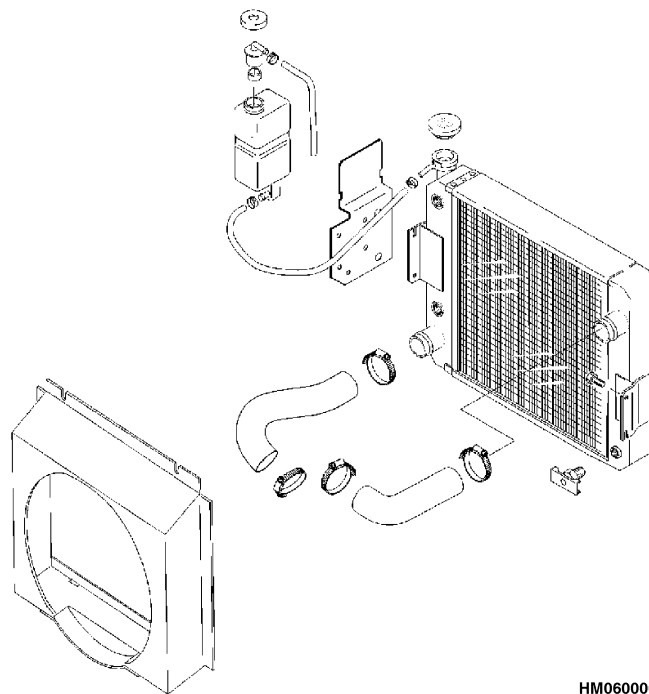


# COOLING SYSTEM

## INTERNAL COMBUSTION ENGINE POWERED UNITS



HM060000

CLICK HERE TO **DOWNLOAD** THE COMPLETE MANUAL

- Thank you very much for reading the preview of the manual.
- You can download the complete manual from: [www.heydownloads.com](http://www.heydownloads.com) by clicking the link below



- Please note: If there is no response to CLICKING the link, please download this PDF first and then click on it.

CLICK HERE TO **DOWNLOAD** THE COMPLETE MANUAL

Table 1. Movement Rates (Maximum) for Tilt Cylinders (Continued)

Lift Truck Model	Hydraulic Oil Temperature/Mast Tilt Rate			
	20°C (68°F)		60°C (140°F)	
	mm/min	in./min	mm/min	in./min
GDP/GLP80-120DB (GP/GDP/GLP170-280DB), GDP/GLP130-160EB (GP/GDP/GLP300-360EB)	1.8	0.07	11.7	0.05
GLC60-70CA (GC/GLC/GDC135-155CA)	1.2	0.05	8.2	0.32

## Tilt Cylinder Stroke and Mast Tilt Angle Adjustment

Adjust the tilt cylinders as described in the **Mast** section.

## Torque Specifications

### PISTON ROD NUT

#### ERP16-20ATF

163 to 190 N•m (120 to 140 lbf ft)

ERC20-30AGF (ERC040-065GH) (A908),  
ERC20-30AGF (ERC040-065RF/ZF RG/ZTG)  
(E108), ERP20-30ALF (B216), and ERP20-30ALF  
(ERP040-060DH) (D216/E216)

150 N•m (110 lbf ft)

ERC35-55HD/HG (ERC070-120HD/HG) (A839) and  
ERC35-55HG (ERC70-120HH) (B839/C839)

400 to 440 N•m (295 to 325 lbf ft)

GC/GLC030-040AF, GDP/GLP16-20AF  
(GP/GLP/GDP030-040AF), ERC/P16-20AAF  
(ERC030-040AF, AG/BG) (A814), and  
ERC/P16-20AAF (ERC030-040AH) (B814/C814)

163 to 190 N•m (120 to 140 lbf ft)

GC/GLC040-065RG/TG/ZG, GLP/GDP20-30RF/TF  
(GP/GLP/GDP040-060RG/TG/ZG)

150 N•m (110 lbf ft)

GP/GLP/GDP070-110LG/MG

400 to 440 N•m (295 to 325 lbf ft)

GDP60-70CA (GP/GLP/GDP135-155CA)

407 to 440 N•m (300 to 325 lbf ft)

GLP/GDP165-280DA

950 to 985 N•m (700 to 725 lbf ft)

GLP/GDP300-360EA

1105 to 1140 N•m (815 to 840 lbf ft)

GDP/GLP80-120DB (GP/GDP/GLP170-280DB),  
GDP/GLP130-160EB (GP/GDP/GLP300-360EB)

950 to 983 N•m (701 to 725 lbf ft)

GP130-160EB (GP300-360EB)

1105 to 1140 N•m (815 to 841 lbf ft)

GC/GLC030-040AF

163 to 190 N•m (120 to 140 lbf ft)

GC/GLC070-120LG/MG

400 to 440 N•m (295 to 325 lbf ft)

GLC60-70CA (GC/GLC/GDC135-155CA)

407 to 440 N•m (300 to 325 lbf ft)

### RETAINER

ERP16-20ATF

163 to 176 N•m (120 to 130 lbf ft)

ERC20-30AGF (ERC040-065GH) (A908),  
ERC20-30AGF (ERC040-065RF/ZF RG/ZG)  
(E108), ERP20-30ALF (B216), ERP20-30ALF  
(ERP040-060DH) (D216/E216)

170 to 237 N•m (125 to 175 lbf ft)

ERC35-55HD/HG (ERC070-120HD/HG) (A839) and  
ERC35-55HG (ERC70-120HH) (B839/C839)

400 to 500 N•m (295 to 370 lbf ft)

## General Check and Adjustment

There are no adjustments for the alternator or most regulators. One Delco alternator and the Leece-Neville alternator has a voltage adjustment.

Always check the general condition of the complete system before doing a complete check on each part. Check the general condition of the following parts: (1) battery, (2) battery cables and connections, and (3) alternator and regulator wires and connectors. Also check the condition and tension of the fan belt for the alternator.



### CAUTION

**NEVER operate the engine if the alternator output BAT terminal is not connected to the battery.**

**Do not short-circuit or connect jumper wires to any of the alternator terminals unless told to by the procedures.**

**Make sure polarity is correct before connecting a battery charger or another battery.**

Remove the battery cables and clean the terminals and cable connectors. Inspect the insulation on the wires. Make sure all the fasteners and connections are clean and tight. If necessary, use a water and soda solution to clean the top of the battery. Do NOT remove the cell caps or permit the water and soda solution to get in the battery.



### WARNING

**Put the transmission in NEUTRAL. Apply the parking brake.**



### CAUTION

**Do not change the polarity of the circuits. Do not connect any wires in the circuits, except as described in these instructions. Never connect the wire from the terminal marked BAT to an open circuit.**

When connecting a charger or another battery, connect the positive terminals to the positive terminal of the battery. Then connect the negative terminal to a clean metal part of the engine. Disconnect the charger or other battery in the reverse order. Problems in the charging circuit are indicated by one or more of the following:

- The starter motor turns slowly. The battery voltage is low because of low alternator output or a bad battery.
- The specific gravity readings are low. Battery is not fully charged or is damaged.
- The battery uses more than 30 ml (1 oz) of water per cell per month. The alternator output is too high.

The two problems of the charging circuit are low output and high output. Low output causes a low battery and difficult starting. A high output causes heating of the battery and evaporation of water from the electrolyte. The following two checks will find out if the alternator, regulator, or wiring has a charging fault. The two checks will also find out if the charging system has a correct output. Do the following two checks before removal, disassembly, or replacement of alternator or regulator.

**NOTE:** Information on alternators manufactured outside the United States is in the YRM sections for lift trucks that use those alternators.

5. Remove the armature from the drive end housing. Tilt the armature to disengage the linkage from the drive clutch. On some models it is necessary to remove the linkage before removing the armature.
6. Remove the thrust collar from the armature shaft. Put a metal tube with a 13 mm (0.5 in.) inside diameter over the end of the shaft. See Figure 4. Hit the tube to move the retainer. Remove the snap ring. Remove the drive clutch.
7. Remove the center bearing plate. Remove the seal from the plate.

## CLEAN



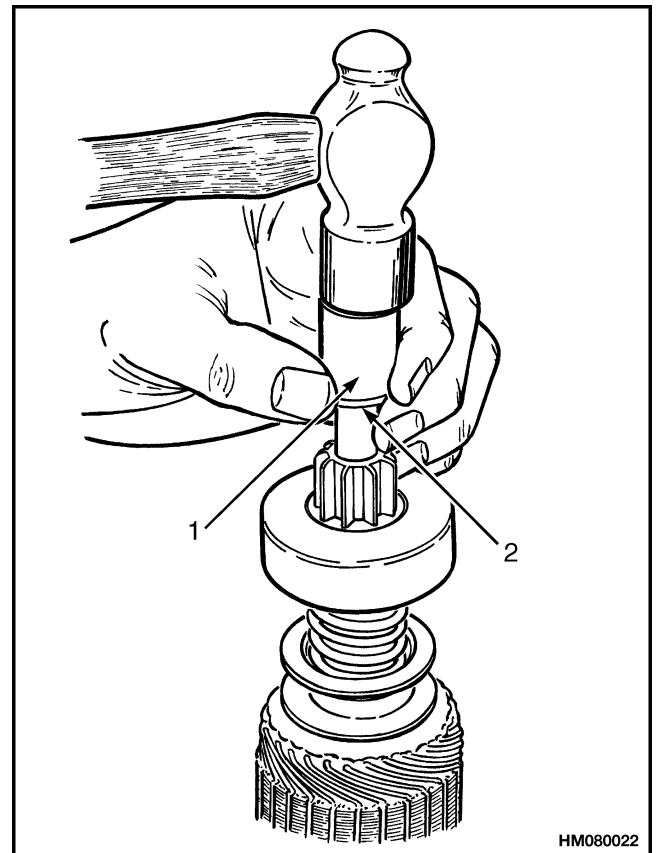
### CAUTION

Never use solvent on the drive clutch, armature, or field windings. Use a cloth to clean these parts.

Use solvent to clean all parts of the starter, except the windings and the drive clutch. Dry the parts with compressed air.

## ASSEMBLE


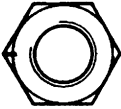
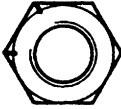
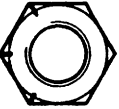
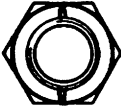





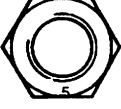



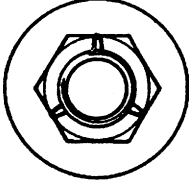
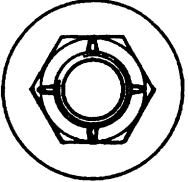
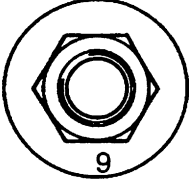
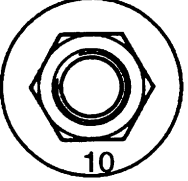
1. Install a new seal in the center bearing plate. See Figure 2 and Figure 5.
2. Lubricate the armature shaft and the bushings with a silicone lubricant.
3. Put the center bearing plate, drive clutch, retainer, snap ring, and thrust washer on the armature shaft. Install the snap ring, thrust washer, and retainer as shown in Figure 5.
4. Install the shaft assembly in the drive end housing. Make sure the linkage is engaged in the drive clutch. Install and tighten the four screws for the bearing plate.
5. Install the field frame over the armature. Retract the brush springs and slide the brushes on the commutator.



1. METAL TUBE, 13 mm (0.5 in.) INSIDE DIAMETER
2. RETAINER

**Figure 4. Retainer Removal**

Table 4. Torque Nuts With Nylon Insert

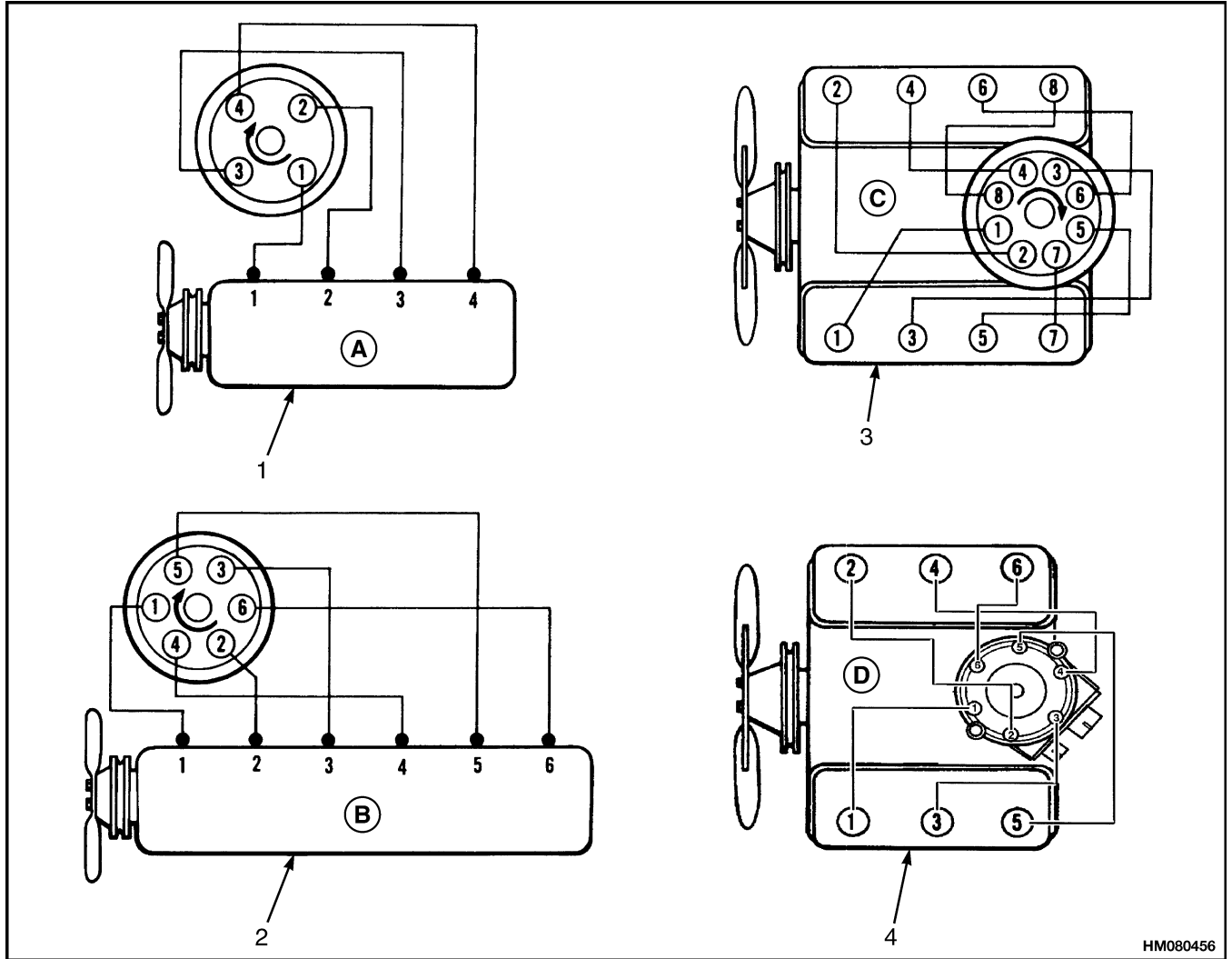
<b>TYPE OF FASTENER</b>	<b>METRIC FASTENERS</b> STRENGTH LEVELS: PROPERTY CLASS	<b>INCH FASTENERS</b> STRENGTH LEVELS: SAE GRADES
 <p>NYLON INSERT PREVAILING TORQUE NUTS</p>	<p>5      9      10</p>    <p>OR</p>    <p>OR</p>    <p>OR</p>   	<p>MARKINGS NOT REQUIRED</p>
 <p>NYLON INSERT PREVAILING TORQUE NUTS</p>	<p>9      10</p>   <p>OR</p>  	<p>MARKINGS NOT REQUIRED</p>

HM210069

Table 6. Torque Values for Inch Fasteners\*

Size and Pitch		Grade 2 <sup>1</sup>		Grade 5 <sup>2</sup>		Grade 8 <sup>3</sup>	
		lbf ft	N•m	lbf ft	N•m	lbf ft	N•m
1/4	1/4 20 UNC 28 UNF	4 5	6 6	6 7	9 10	9 10	12 14
5/16	5/16 18 UNC 24 UNF	8 9	11 13	13 14	18 20	18 20	25 28
3/8	3/8 16 UNC 24 UNF	15 17	20 23	23 26	31 36	33 37	44 50
7/16	7/16 14 UNC 20 UNF	24 27	33 36	37 41	50 56	52 58	71 79
1/2	1/2 13 UNC 20 UNF	37 41	50 56	57 85	77 115	80 90	110 120
9/16	9/16 12 UNC 18 UNF	53 59	72 80	82 91	110 125	115 130	155 175
5/8	5/8 11 UNC 18 UNF	73 83	99 110	115 130	155 175	160 180	215 245
3/4	3/4 10 UNC 16 UNF	130 145	175 195	200 225	270 300	280 315	380 425
7/8	7/8 9 UNC 14 UNF	125 140	170 185	320 355	435 480	455 500	615 680
1	1 8 UNC 14 UNF	185 210	255 285	485 540	655 735	680 765	925 1,040
1-1/8	1-1/8 7 UNC 12 UNF	265 300	360 405	595 670	805 905	965 1,080	1,310 1,470
1-1/4	1-1/4 7 UNC 12 UNF	375 415	510 565	840 930	1,140 1,260	1,360 1,500	1,850 2,050
1-3/8	1-3/8 6 UNC 12 UNF	490 560	665 760	1,100 1,250	1,490 1,700	1,780 2,040	2,420 2,760
1-1/2	1-1/2 6 UNC 12 UNF	650 735	885 995	1,460 1,650	1,980 2,230	2,370 2,670	3,210 3,620

\* Unless otherwise specified <sup>1</sup> Approximately equal to metric Property Class 5.8 <sup>2</sup> Approximately equal to metric Property Class 8.8 <sup>3</sup> Approximately equal to metric Property Class 10.9



HM080456

- A. FIRING ORDER 1-3-4-2
- B. FIRING ORDER 1-5-3-6-2-4

- C. FIRING ORDER 1-8-4-3-6-5-7-2
- D. FIRING ORDER 1-6-5-4-3-2

- 1. FOUR CYLINDER
- 2. SIX CYLINDER

- 3. V8
- 4. V6

Figure 8. Firing Order

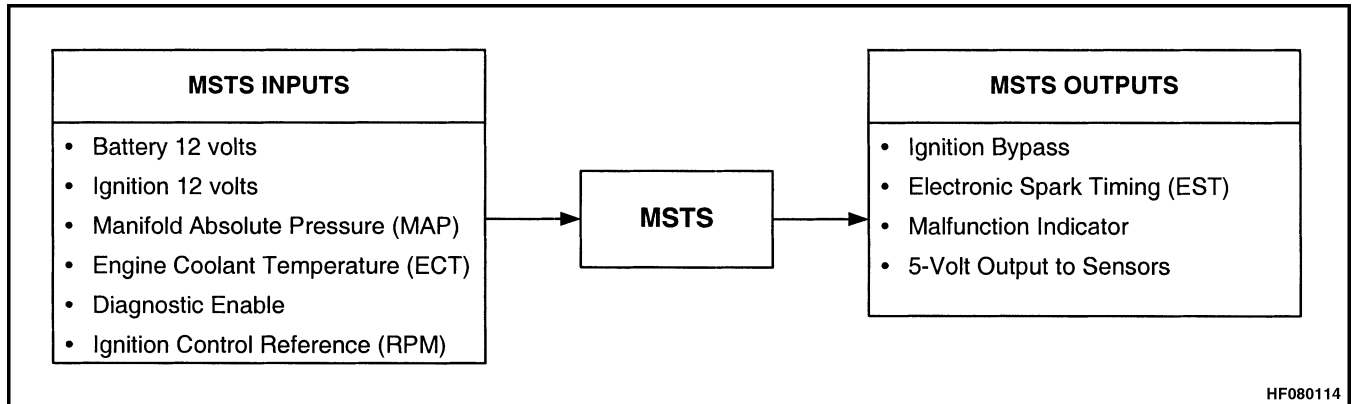


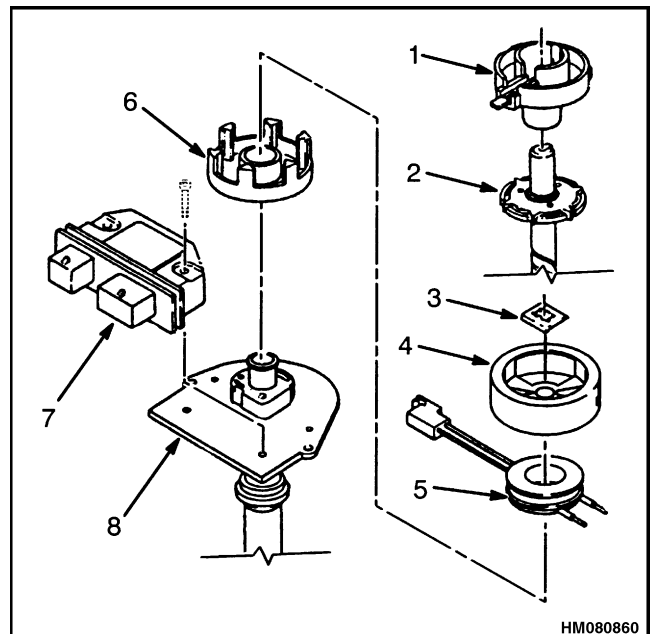
Figure 3. Electronic Engine Control System

## Operation

### DISTRIBUTOR

The distributor uses an internal magnetic pickup assembly that consists of a permanent magnet, pole piece with internal teeth and pickup coil. See Figure 4. When the rotating teeth of the timer core (permanent magnet) line up with the teeth of the pole piece, voltage is induced in the pickup coil. This voltage signals the ignition control module to trigger the primary ignition circuit bypass mode. Current flow in the primary circuit is interrupted and a high voltage of up to 35,000 volts is induced in the ignition coil secondary winding. This high voltage is directed through the secondary ignition circuit to fire the spark plugs.

The principle of magnetic induction also controls the polarity of the voltage generated in the pickup coil. An increasing magnetic field will generate a voltage in the coil that is the opposite polarity of a magnetic field that is decreasing. This signal pulse causes the integrated circuits in the ignition module to generate a square wave signal. The ignition module and a magnetic pulse generator control the primary circuit to the ignition coil when the engine is started. After the engine is started, the MSTS module receives the square wave signal from the magnetic pulse generator and ignition module as one of the signals to control the EST. The pole piece has the same number of teeth as the engine has cylinders so that a spark voltage is correctly sent to each spark plug as the shaft in the distributor rotates.



- |                     |                    |
|---------------------|--------------------|
| 1. ROTOR            | 5. COIL            |
| 2. TIMER CORE/SHAFT | 6. POLE PIECE      |
| 3. RETAINER         | 7. IGNITION MODULE |
| 4. SHIELD           | 8. HOUSING         |

Figure 4. Distributor

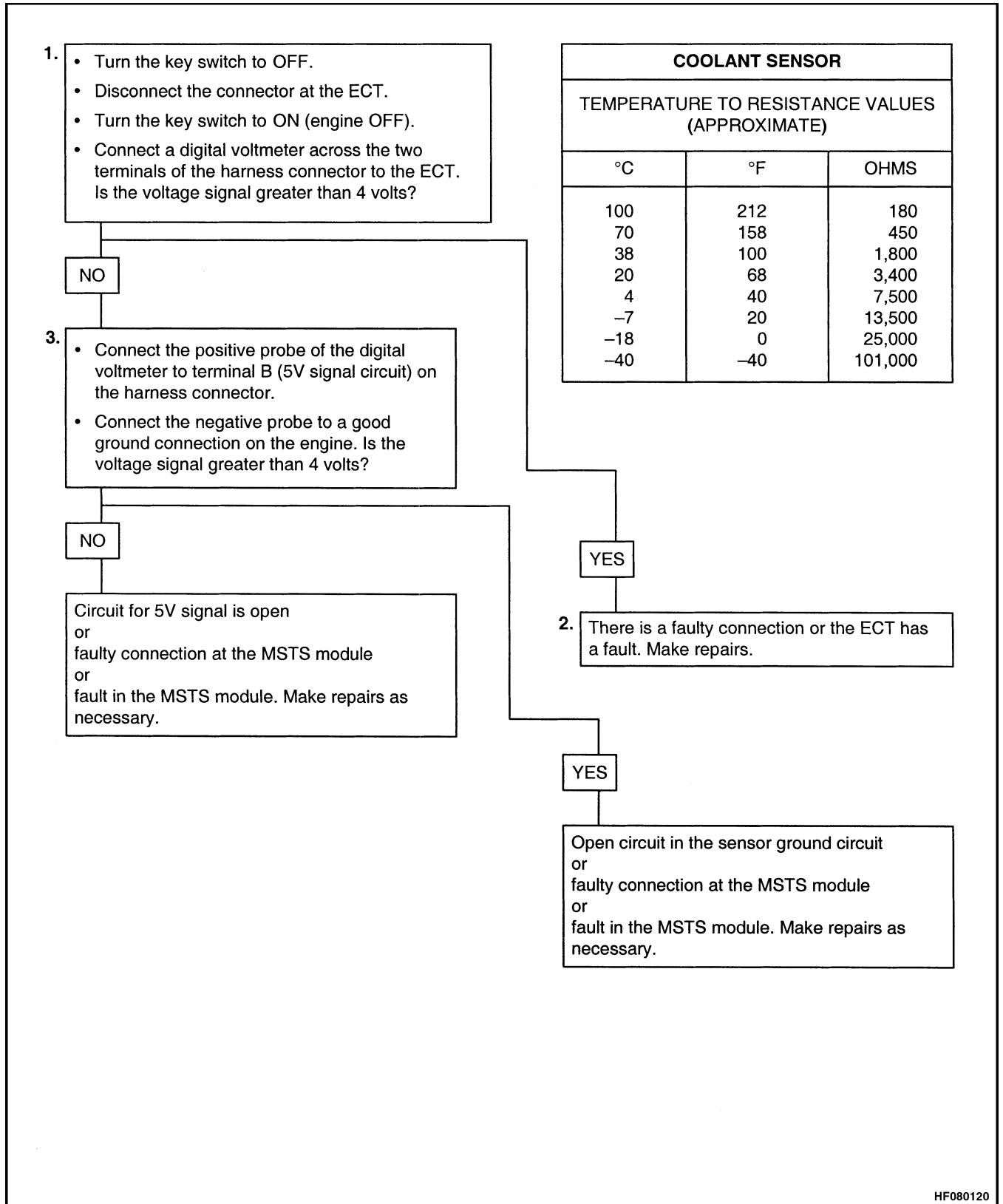


Figure 21. ECT Sensor Troubleshooting Diagram (Low Temperature)

## TABLE OF CONTENTS

General.....	1
Description and Operation.....	1
General .....	1
Electronic Control Module (ECM).....	1
Diagnostic Connector .....	1
How ECM Begins Operation.....	5
Electronic Engine Control.....	6
What ECM Does .....	6
Distributor .....	8
Ignition Module .....	8
When Engine Is Being Started.....	9
When Engine Is Running .....	10
Electronic Control Module (ECM) with Ignition Module Distributor, Corrections .....	10
Fuel Control.....	11
Throttle Body Injection (TBI).....	12
Fuel Injectors .....	12
Fuel Pressure Regulator.....	12
Throttle Position Sensor (TPS) .....	13
Idle Air Control (IAC).....	13
GM 4.3L Engine Governor System.....	14
GM 3.0L Engine Governor System.....	14
Vacuum Ports.....	16
Fuel Pump .....	16
ECM Sensors and Controllers.....	18
Manifold Absolute Pressure (MAP).....	18
Engine Coolant Temperature (ECT) Sensor .....	18

This section is for the following models:

GM 3.0L Engine GP/GLP/GDP2.00-3.00RF/TF (GP/GLP/GDP040-060RG/TG/ZG) [A875];  
 GC/GLC040-065RG/TG/ZG [E187]  
 GM 4.3L Engine GDP60-70CA (GP/GLP/GDP135-155CA) [A878];  
 GLC60-70CA (GC/GLC/GDC135-155CA) [A879];  
 GP/GLP/GDP070-110LG/MG [B813];  
 GC/GLC070-120LG/MG [B818]

# ELECTRONIC ENGINE CONTROL

## TROUBLESHOOTING AND REPAIR

### GM 3.0L ENGINE

GP/GLP/GDP2.00-3.00RF/TF

(GP/GLP/GDP040-060RG/TG/ZG) [A875];

GC/GLC040-065RG/TG/ZG [E187]

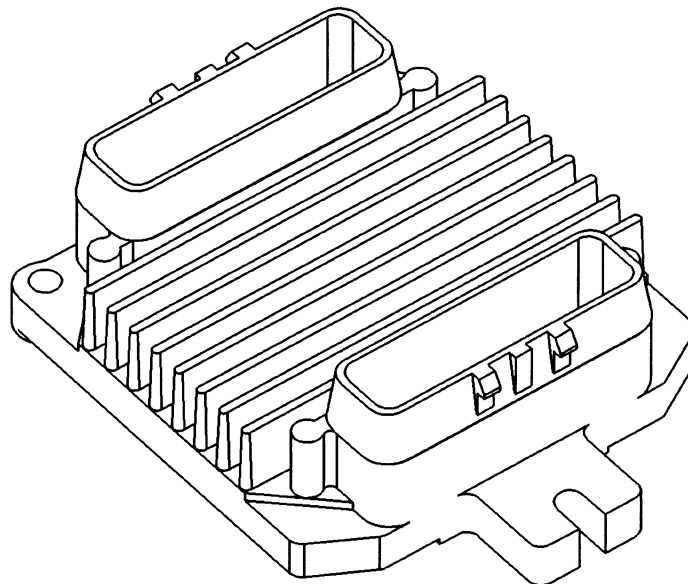
### GM 4.3L ENGINE

GDP60-70CA (GP/GLP/GDP135-155CA) [A878];

GLC60-70CA (GC/GLC/GDC135-155CA) [A879];

GP/GLP/GDP070-110LG/MG [B813];

GC/GLC070-120LG/MG [B818]



HM081022

## A-3 - Starter Rotates Engine, Engine Will Not Run

### CIRCUIT DESCRIPTION

Before using this chart, battery condition, engine cranking speed, and fuel quantity must be checked to make sure they are correct. See Figure 12.

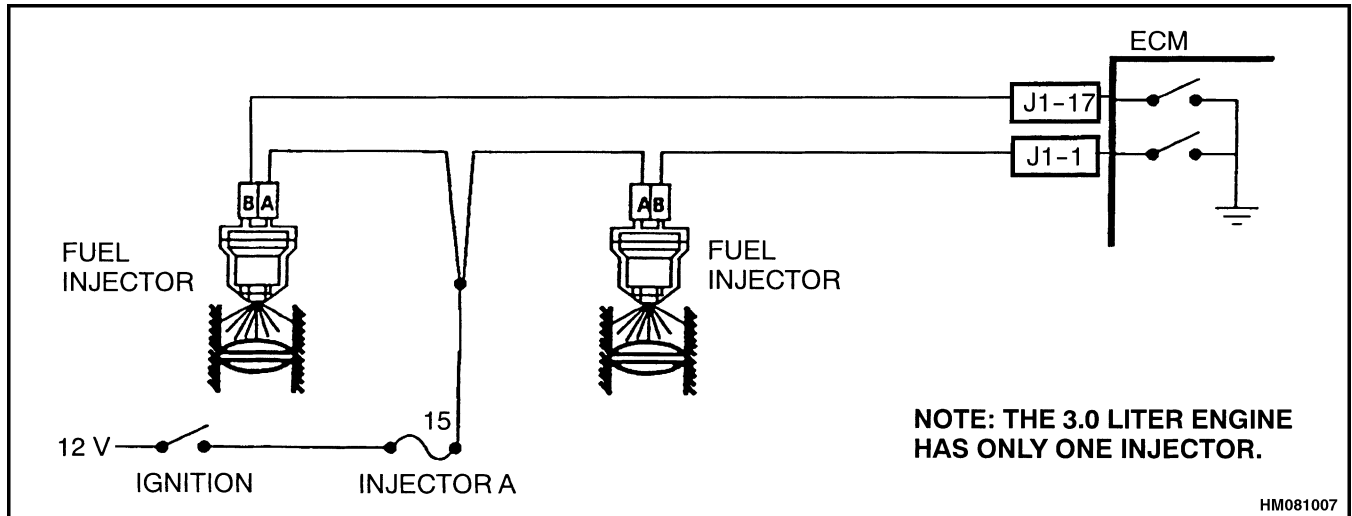


Figure 12. Chart A-3 - Starter Rotates Engine, Engine Will Not Run

### TEST DESCRIPTION

The numbers below are a reference to the bold numbers in Figure 13.

1. A Malfunction Indicator Lamp ON is a test to determine if there is battery and ignition voltage at the ECM.
  - If no SCAN data is caused by an ECM problem, Figure 11 will diagnose the ECM.
  - If throttle or coolant sensors are not within these ranges, the ECM can be using the wrong mode for starting.
  - SCAN Tool will display RPM during cranking if pulses are received at the ECM.
2. If RPM was indicated during crank, the ignition module is receiving a crank signal, but No Spark at this test indicates the ignition module is not triggering the coil.
3. While cranking engine, there must be no fuel spray with the injector electrical connector disconnected. Replace injector or seals if fuel sprays or drips.

4. Test light will flash, indicating the ECM is controlling the injector.
5. Fuel spray from the injector indicates that fuel is available. However, the engine can be getting too much fuel. No fuel spray from injector indicates a fault in the fuel system or no ECM control of injector.

### OTHER TROUBLESHOOTING CHECKS

- Water or foreign material can cause a no start condition during freezing weather. The engine can start after approximately 5 minutes in a heated shop.
- A MAP sensor voltage reading between 0.5 to 3.0 volts can cause a no start condition. Disconnect the MAP sensor. If the engine starts, replace the MAP sensor. See MAP Sensor, Replace in Sensors Repair.
- If fuel pump fuse is damaged, test current draw of pump motor in tank. If more than 5 to 6 amps, correct the circuit or replace the pump motor in the tank.

## DTC 31 Engine Governor Circuit

### CIRCUIT DESCRIPTION

The ECM sends a controlled signal pulse to the governor control module (circuit **JR**) to drive the governor motor. See Figure 32.

Depending on the need of the engine for the governor, the module translates the ECM data into the correct value of D.C. current (circuits **JP** and **JQ**) to the motor. This current causes the motor to limit engine speed

by loosening the throttle cable. The system is capable of reducing the throttle back to near idle position.

A DTC 31 will find a damaged ECM, governor module, motor, linkage, or wiring. If DTC 31 is set, the ECM will limit engine RPMs by momentarily reducing fuel (at a slightly higher RPMs than governor calibration).

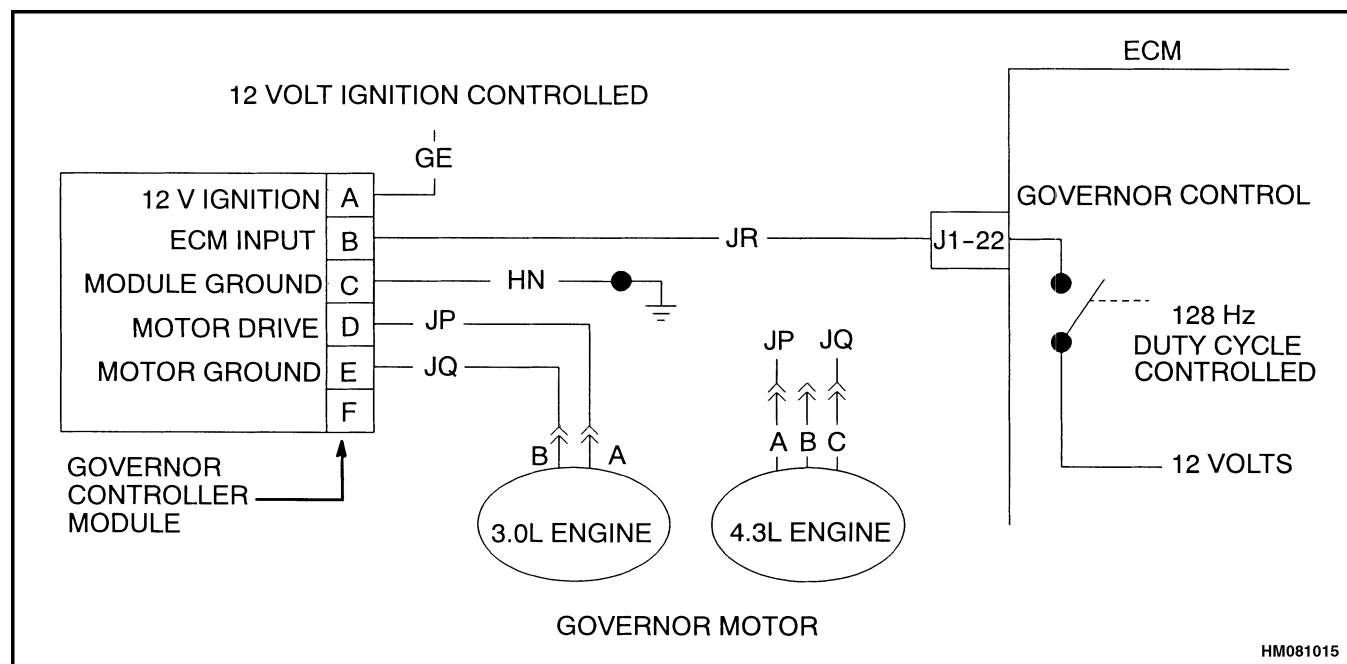


Figure 32. DTC 31 Engine Governor Circuit

### TEST DESCRIPTION

The numbers below are a reference to bold numbers in Figure 33.

DTC 31 will set if the ECM is commanding near 100% authority.

1. This check determines if the governor control module has a voltage supply to operate.



### CAUTION

**DO NOT** hold current to the motor for longer than 30 seconds, as the motor can be damaged.

2. Applying Battery + to motor will not let the throttle plate open.
3. This test requires complete governor control to determine if ECM or governor system has a fault. Throttle plate must not open during this test.

### OTHER TROUBLESHOOTING CHECKS

A SCAN Tool displays governor TPS. Watch this value as engine rpm increases beyond the governor limits. This test will allow you to see the ECM's control try to limit engine speed.

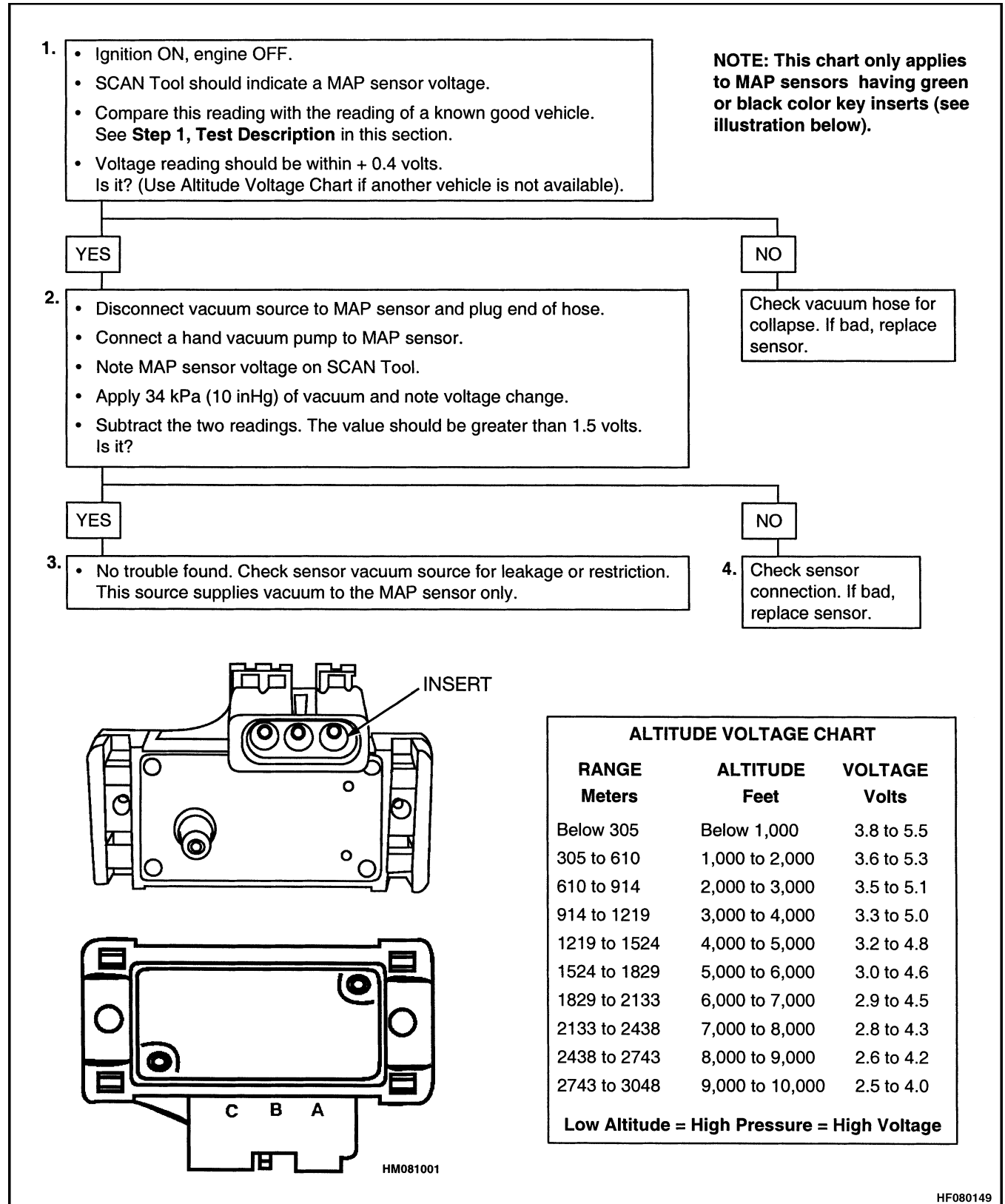
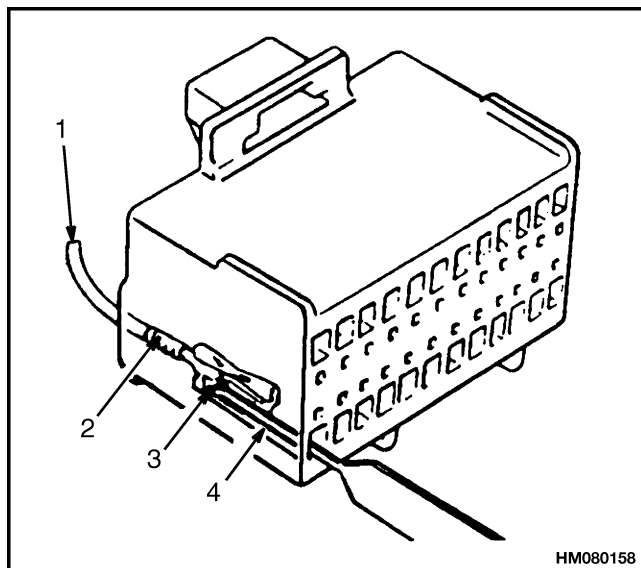


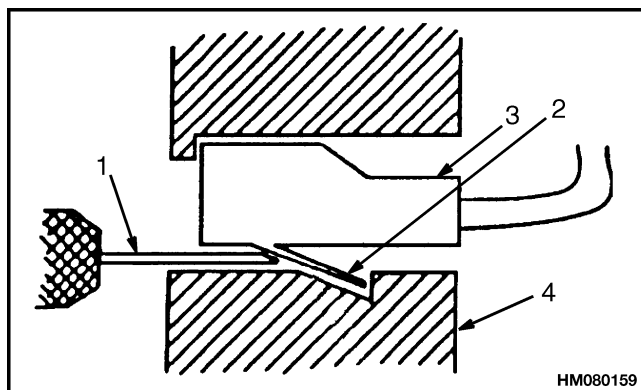
Figure 49. Chart B-2 - Manifold Absolute Pressure (MAP) Sensor Output Test



- |             |                                  |
|-------------|----------------------------------|
| 1. WIRE     | 4. YALE TOOL KIT<br>OTC P/N 7733 |
| 2. TERMINAL |                                  |
| 3. LOCK TAB |                                  |

**Figure 78. Micro-Pack Connector**

**Metri-Pack® Connectors**, shown in Figure 79, come in several sizes and types that are used on the wire harness. These connectors are made by Packard Electric Company. The typical connectors used on lift trucks are No. 56, No. 150, No. 280, No. 480, and No. 630. Some of these connectors are push-to-seat and others are pull-to-seat. Make sure connector is correctly identified before it is changed. Terminals can be damaged if they are removed or installed wrong.



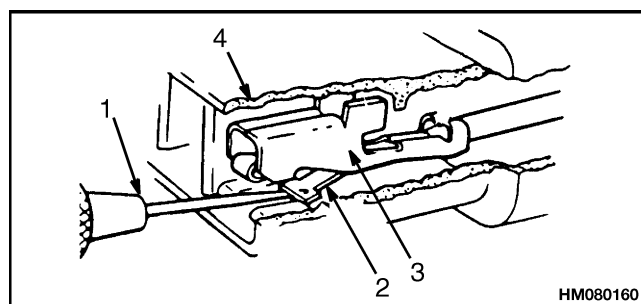
- |             |                      |
|-------------|----------------------|
| 1. PICK     | 3. TERMINAL          |
| 2. LOCK TAB | 4. CONNECTOR<br>BODY |

**Figure 79. Metri-Pack Push-to-Seat Connector**

**NOTE:** Not all **Metri-Pack** connectors have a seal.

Do the following procedures to remove and install a terminal:

1. Open any secondary locks that hold wires and seals in their positions. Slide seals along wires from ends of connector.
2. Hold wire and use it to push terminal to its forward position in connector body. Hold terminal in this position.
3. Find lock tab for terminal in connector channel. Push a removal tool (pick) of correct size into connector channel. See Figure 78 and Figure 80.



- |             |                      |
|-------------|----------------------|
| 1. PICK     | 3. TERMINAL          |
| 2. LOCK TAB | 4. CONNECTOR<br>BODY |

**Figure 80. Metri-Pack Pull-to-Seat Connector**

4. Use removal tool to move lock tab and release terminal from its seat.

**Push-To-Seat** - Gently pull wire to remove terminal from back of connector. See Figure 80.

**Pull-To-Seat** - Gently push wire to remove terminal through front of connector. See Figure 81.



### CAUTION

Work carefully and do not use enough force to damage terminal or connector.

5. Inspect terminal and connector for damage. Make repairs as necessary. See Figure 82.
6. If terminal will be used again, make sure lock tab is correctly bent so that terminal will be locked in connector again.

## Counterweight Repair

### WARNING

The lift truck must be put on blocks for some types of maintenance and repair. The removal of the following assemblies will cause large changes in the center of gravity: mast, drive axle, engine and transmission, and counterweight. When the lift truck is put on blocks, put additional blocks in the following positions to maintain stability:

- Before removing the mast and drive axle, put blocks under the counterweight so the lift truck cannot fall backward.
- Before removing the counterweight, put blocks under the mast assembly so the lift truck cannot fall forward.

The surface must be solid, even, and level when the lift truck is put on blocks. Make sure that any blocks used to support the lift truck are solid, one-piece units. See the Operating Manual or Periodic Maintenance 8000 YRM 707 for your lift truck.

The counterweight is held in position on the frame by two hooks that are part of the frame. One M24 × 3 capscrew holds the counterweight to the lower part of the frame.

### REMOVE

### WARNING

Do not operate the lift truck if the capscrew for the counterweight is not installed. When the capscrew is removed, the counterweight can fall from the lift truck.

### WARNING

LPG can cause an explosion. Do not cause sparks or permit flammable material near the LPG system. LPG fuel systems can be disconnected indoors only if the lift truck is at least 8 m (26 ft) from any open flame, motor vehicles, electrical equipment, or ignition source.

Close the shutoff valve on the LPG tank before any part of the engine fuel system is disconnected. Run the engine until the fuel in the system is used and the engine stops.

If the engine will not run, close the shutoff valve on the LPG tank. Loosen the fitting on the supply hose from the LPG tank where it enters the filter unit. Permit the pressure in the fuel system to decrease

slowly. Fuel leaving the fitting removes heat. Use a cloth to protect your hands from the cold fitting.

1. If the lift truck has an LPG fuel system, use the following procedure to remove the LPG tank and bracket so that the counterweight can be removed. See Figure 5.

Additional information on the LPG fuel system can be found in the following sections: **LPG Fuel System, GM 2.2L and 3.0L Engines** 900 YRM 498, **LPG Fuel System, Mazda FE Engine** 900 YRM 523, or **Electronic Controlled LPG/Gasoline Fuel System, GM 3.0L and 4.3L EPA Compliant Engines** 900 YRM 1088.

- a. LPG tanks can be removed and replaced indoors only if the lift truck is at least 8 m (26 ft) from any flame or ignition source.
  - b. Move the lift truck to the area where tanks are changed.
  - c. Turn the shutoff valve clockwise until the valve is completely closed.
  - d. Run the engine until it stops, then turn the key switch to the **OFF** position.
  - e. Disconnect the quick-disconnect fitting.
  - f. Release the LPG tank latch and remove the tank from the bracket.
2. If an overhead exhaust is installed, remove it as shown in Figure 12.

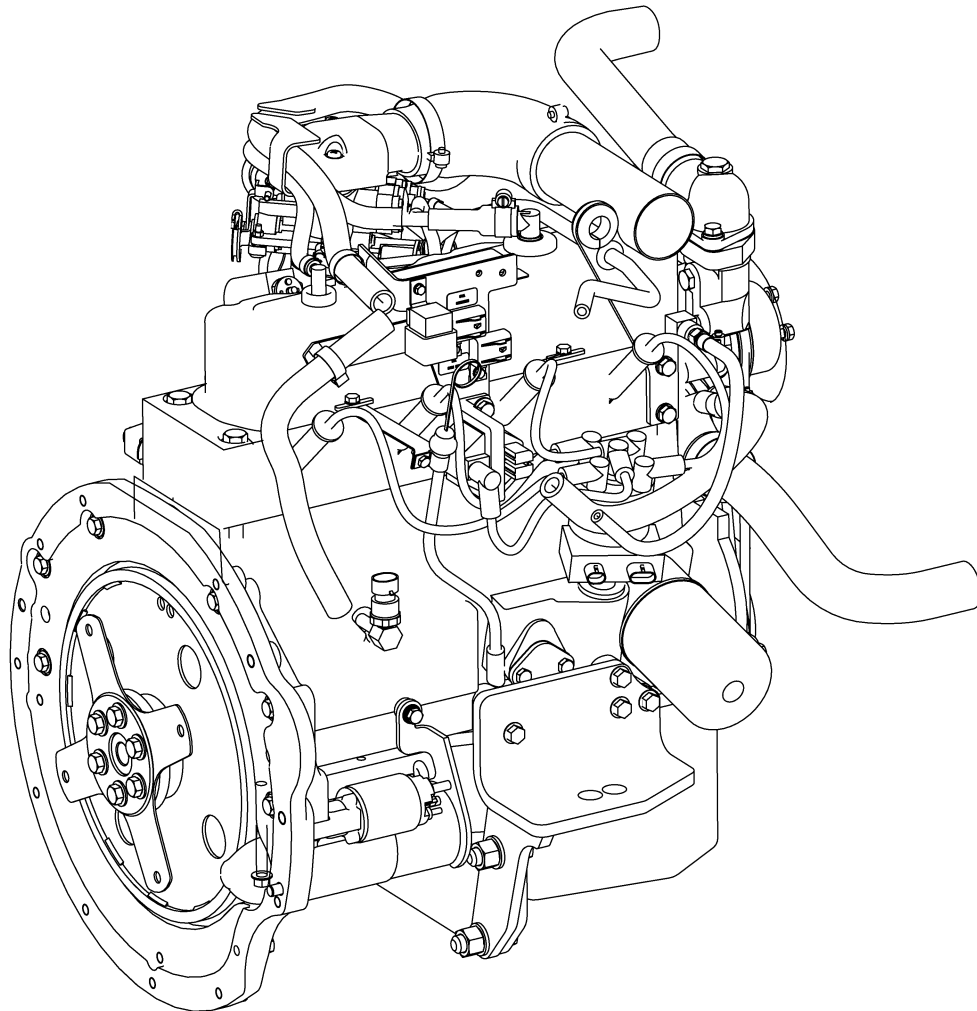
### WARNING

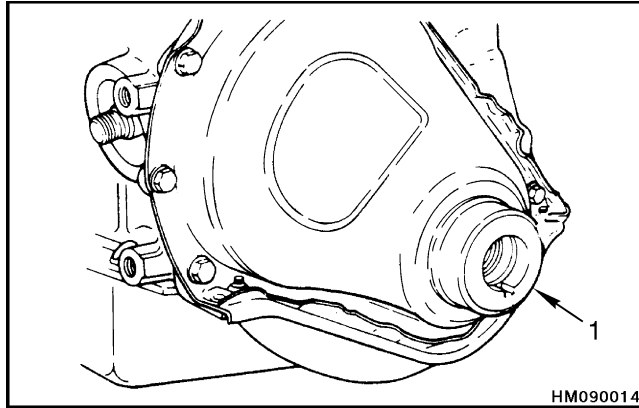
The counterweight is heavy. Make sure that the eyebolt and lifting devices have enough capacity to lift the weight. The approximate weights of the counterweight castings are shown in Table 1.

3. Install a lifting eye in the lifting hole of the counterweight. See Figure 5. Connect a crane to the lifting eye and raise the crane until it holds part of the weight of the counterweight. Remove the capscrew that holds the counterweight to the frame. Use the crane to lift the counterweight from the lift truck. Put the counterweight on the floor so that it has stability and will not fall over. Remove the spacers from the mounts.

# **GM ENGINE REPAIR**

## **GM 3.0 LITER ENGINE**





1. CENTERING TOOL

**Figure 25. Timing Gear Cover Centering Tool**

6. Install the timing gear cover. Install the two screws for the oil pan and the screws for the timing gear cover and tighten the screws with your fingers.

Make sure the oil seal is correctly aligned. Tighten the screws to 10 N•m (89 lbf in).

7. Remove the centering tool.
8. Install the vibration damper. Use a tool that presses on the center of the vibration damper. See Figure 24. Do not use a tool that pushes on the outside diameter of the vibration damper. Make sure the hub of the vibration damper is against the crankshaft gear.
9. Install the pulley on the vibration damper. Tighten the capscrews to 44 N•m (32 lbf ft). Install the drive belts and adjust the belts as required. See the **Periodic Maintenance** section for your lift truck model for the adjustment procedures.
10. If the cooling system is complete, fill the system with coolant and check for leaks.

## Timing Wheel Repair

### TIMING WHEEL, REMOVAL

1. Shut down the engine.
2. Place the number one cylinder at TDC on the compression stroke.
3. Remove serpentine belt. See **Periodic Maintenance** for your lift truck.
4. Remove three bolts, washers, and serpentine belt pulley from timing wheel.



#### CAUTION

When removing the timing wheel, **DO NOT** use a puller that pulls on the outside diameter of the timing wheel as damage can occur.

**NOTE:** The timing wheel is pressed onto the crankshaft. It must be pulled off with a puller.

5. Remove the timing wheel. Carefully use a puller that pulls on the center of the timing wheel. Do not use a puller that pulls on the outside diameter of the timing wheel.
6. If necessary, remove two woodruff keys from the crankshaft.

### TIMING WHEEL, INSTALL

**NOTE:** When installing timing wheel, ensure wheel is facing correct side out.

**NOTE:** There is a small hole near the large gap in the teeth. This hole must be aligned with the mark on the serpentine belt pulley when installing.

1. If the woodruff keys were removed, install them into the crankshaft.



#### CAUTION

When replacing the timing wheel, use a rubber mallet on the center and **NOT** the outside diameter of the timing wheel as damage can occur.

**Verify that timing wheel is against the crankshaft. Not pressing the timing wheel against the crankshaft can result in further damage to equipment.**

2. Install the timing wheel. Use a rubber mallet to start tapping the timing wheel on the crankshaft. Do not use a tool that pushes on the outside diameter of the timing wheel. Make sure the hub of the timing wheel is against the crankshaft gear.
3. Drive the timing wheel onto the shaft with a series of taps. As soon as you are certain it is square, you

**RING GEAR, REPLACE****WARNING**

Wear eye protection for this operation to prevent eye injury from metal chips. You will be using a hammer and driver to remove the ring gear.

1. Use the following procedure to remove the ring gear from the flywheel:
  - a. During removal or installation, do not heat the ring gear greater than 230°C (450°F). Heat the circumference of the ring gear evenly and carefully remove it from the flywheel with a hammer and driver.

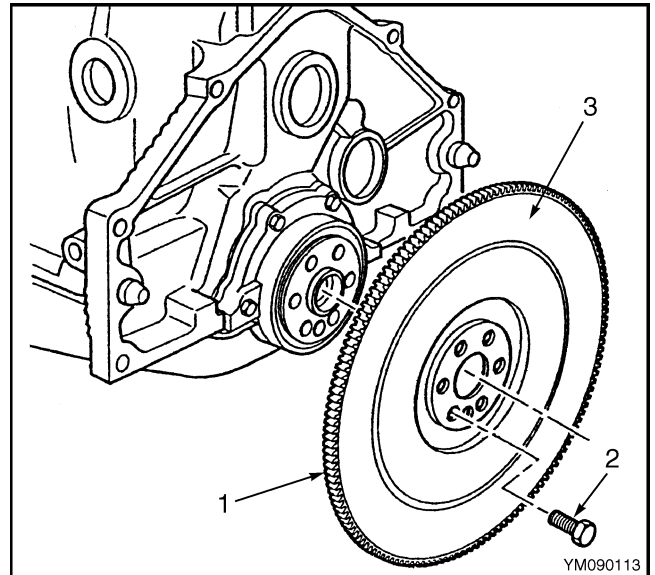
**WARNING**

Hot parts. Wear protective clothing and gloves to prevent burns.

- b. Heat the new ring gear to 200°C (390°F) in an oven and install the ring gear on the flywheel. Push the ring gear fully against the shoulder of the flywheel.
- c. The bearing in the flywheel can be replaced. Push the old bearing from the flywheel and push in a new bearing.

**FLYWHEEL, INSTALL**

1. Install the engine flywheel. See Figure 64.
2. Install the flywheel bolts and tighten them to 88 N•m (65 lbf ft).



- |              |             |
|--------------|-------------|
| 1. RING GEAR | 3. FLYWHEEL |
| 2. BOLT      |             |

*Figure 64. Flywheel Installation*

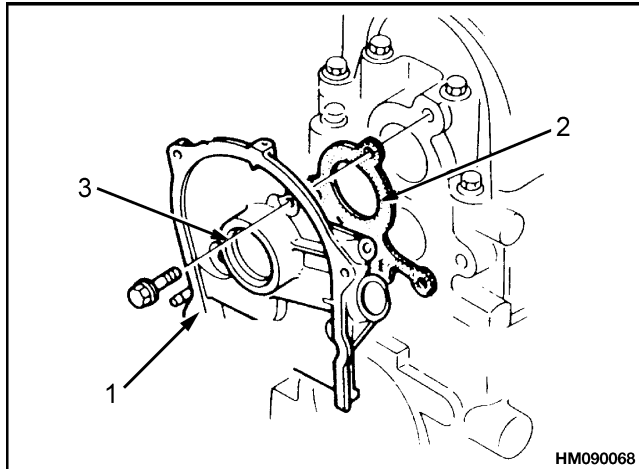
**Cooling System Repair****WATER PUMP****Remove**

**NOTE:** This section covers the removal, inspection, and installation of the water pump and the removal and installation of the thermostat. For a description of how the water pump, thermostat, and other components of the cooling system operate, see the section **Cooling System** 700 YRM 626.

1. Drain engine coolant from the cooling system.
2. Remove the water pump bolts. See Figure 65.
3. Remove the water pump and gasket. Discard the water pump gasket.

**Inspect**

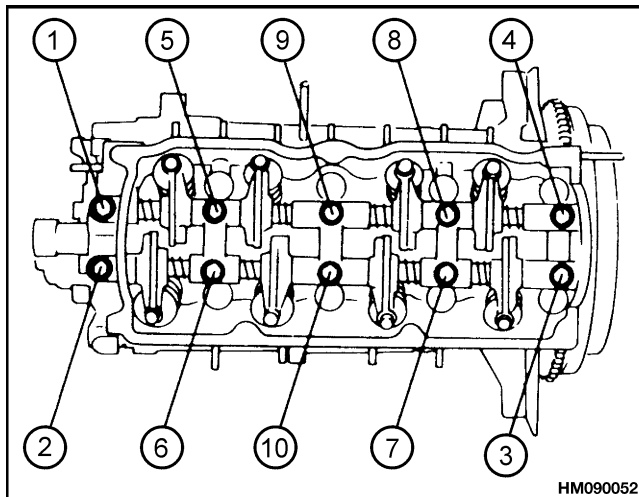
1. Inspect the water pump for the following:
  - a. Worn or damaged gasket sealing surfaces.
  - b. Excessive side-to-side play in the pulley shaft.
  - c. Leakage at the water inlet housing or rear cover gasket areas.
  - d. Leakage at the water pump vent hole. A stain around the vent hole is acceptable. If leakage occurs at the vent hole with the engine running and the cooling system pressurized, replace the pump.



- 1. FRONT HOUSING
- 2. GASKET
- 3. OIL SEAL

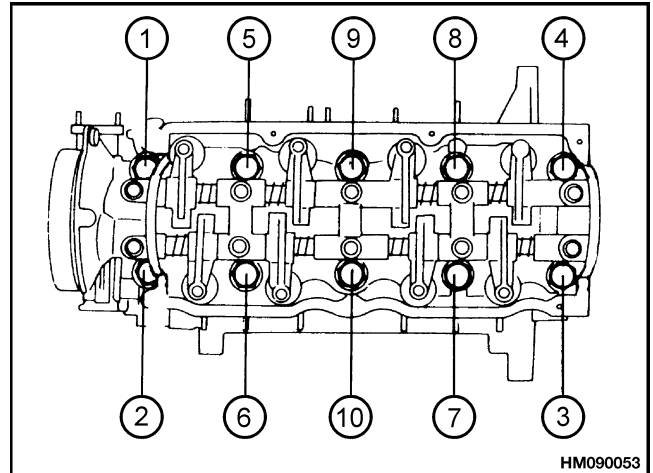
**Figure 4. Front Housing**

- 12. Remove valve cover.
- 13. Loosen capscrews for rocker shaft supports in proper sequence. See Figure 5. Remove rocker shaft assembly and camshaft.



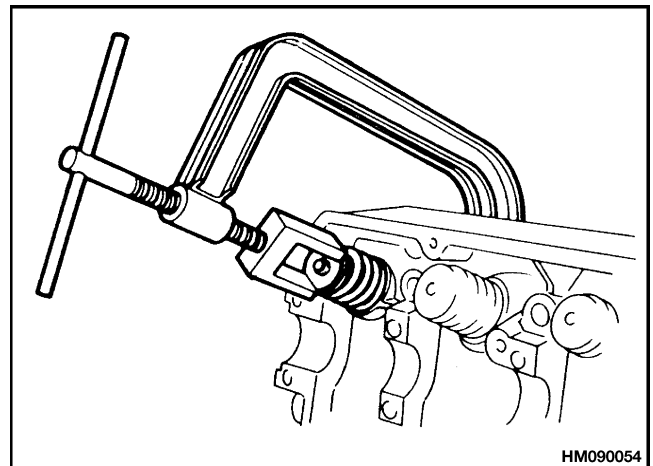
**Figure 5. Rocker Assembly Removal Sequence**

- 14. Remove capscrews for cylinder head in proper sequence. See Figure 6.
- 15. Lift cylinder head from the block.



**Figure 6. Cylinder Head Removal Sequence**

- 16. Use valve spring compressor to remove valve retainers, springs, and valves from head. See Figure 7.



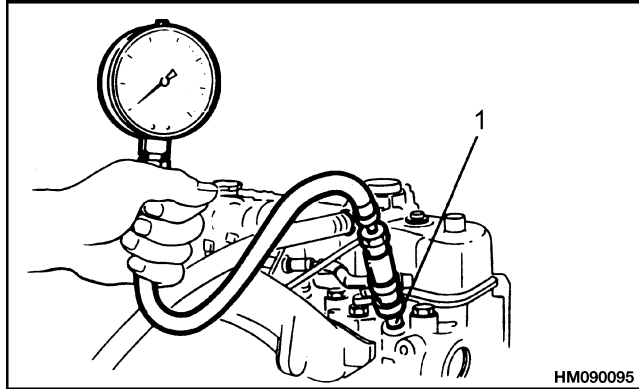
**Figure 7. Valve Removal**

**CLEAN**

**WARNING**

Cleaning solvents can be flammable and toxic and can cause skin irritation. When using cleaning solvents, always follow the solvent manufacturer's recommended safety procedures.

Clean all parts in solvent. Make sure all oil passages are clean and all machined surfaces are smooth.



## 1. ADAPTER

**Figure 53. Compression Pressure Check**

4. If the readings are lower than minimum reading, there is a problem with the valves, piston rings, or cylinder head gasket. Do the following tests to find the problem:
  - a. Add approximately 30 ml (1.0 oz) of engine oil to each cylinder at spark plug hole.
  - b. Crank engine approximately 10 revolutions to distribute oil.
  - c. Install compression gauge and do same tests as described in Step 3.
    - If pressure reading increases to normal reading, low pressure was caused by worn or damaged piston rings. Cylinder bore may also be damaged.
    - If pressure reading does not increase, low pressure was caused by worn valves, valve seats, or valve guides.
    - If low pressure readings are in two cylinders next to each other, cylinder head may be leaking.

## Engine Timing Adjustment

See Ignition System Check and Adjustment in the section **Electrical System, Mazda FE and F2 Gasoline/LPG Engines** 2200 YRM 524 for the adjustment procedure for engine timing.

The correct timing for the GP/GLP/GDP16-20AF/BF (GP/GLP/GDP030-040AF/BF), GC/GLC030-040AF, and GLP/GDP16-20AF (GP/GLP/GDP030-040AF) units is as follows:

- **Gasoline Engine** = 0° BTDC @ 725 ±25 rpm (white mark)

- **LPG Engine** = 8° BTDC @ 725 ±25 rpm

The correct timing for the GC/GLC040-065RG/TG/ZG and GP/GLP/GDP2.0-3.0RF/TF (GP/GLP/GDP040-060RG/TG/ZG) units is as follows:

- **Gasoline Engine** = 0° BTDC @ 725 ±25 rpm (white mark)
- **LPG Engine** = 9° BTDC @ 725 ±25 rpm (red mark)

## Throttle Linkage Adjustment

Whenever the throttle linkage is disassembled, the throttle cable must be adjusted after installation.

### GASOLINE ENGINES

See the section **Gasoline Fuel System** 900 YRM 547 for the correct adjustment procedure for lift truck models:

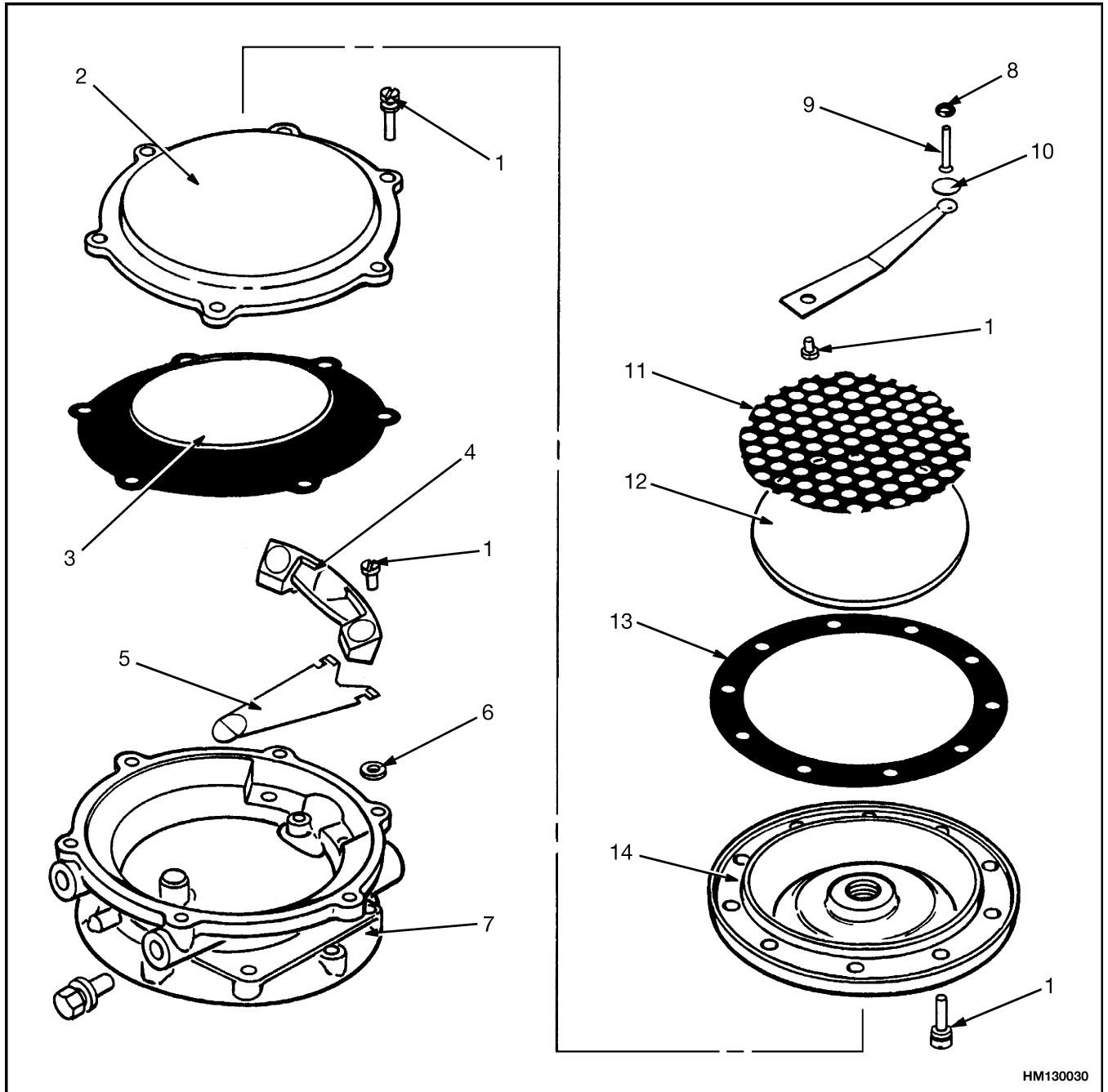
- GP/GLP/GDP16-20AF/BF (GP/GLP/GDP030-040AF/BF), GC/GLC030-040AF, and GLP/GDP16-20AF (GP/GLP/GDP030-040AF)

See the section **Gasoline Fuel System, Mazda FE and F2 Engines** 900 YRM 502 for the correct adjustment procedure for lift truck models:

- GP/GLP/GDP2.0-3.0RF/TF (GP/GLP/GDP040-060RG/TG/ZG) and GC/GLC040-065RG/TG/ZG

### LPG ENGINES (IMPCO)

For earlier units, see the section **LPG Fuel System, Mazda FE Engine** 900 YRM 523 for the correct adjustment procedure.



HM130030

- 1. SCREW
- 2. DIAPHRAGM COVER
- 3. DIAPHRAGM
- 4. FULCRUM
- 5. LEVER
- 6. WASHER
- 7. BODY

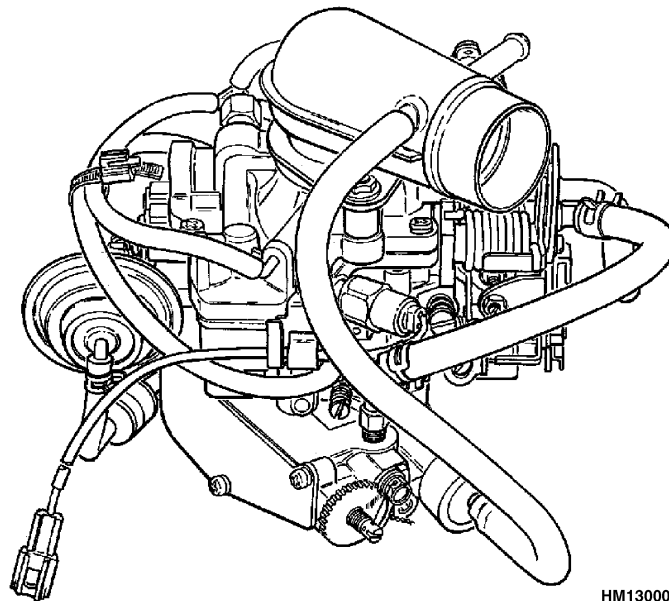
- 8. O-RING
- 9. PIN
- 10. VALVE PAD
- 11. SCREEN
- 12. FILTER
- 13. GASKET
- 14. FILTER COVER

Figure 11. Fuel Valve and Fuel Filter

# **GASOLINE FUEL SYSTEM**

## **MAZDA FE AND F2 ENGINES**

**GP/GLP/GDP2.00-3.00RF/TF  
(GP/GLP/GDP040-060RG/TG/ZG) [A875];  
GC/GLC040-065RG/TG/ZG [E187]**

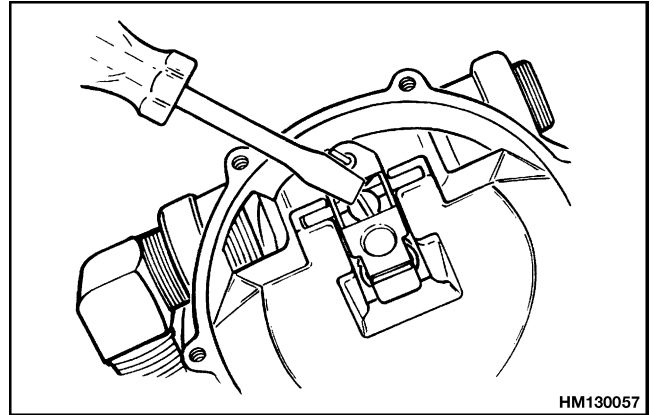


HM130000

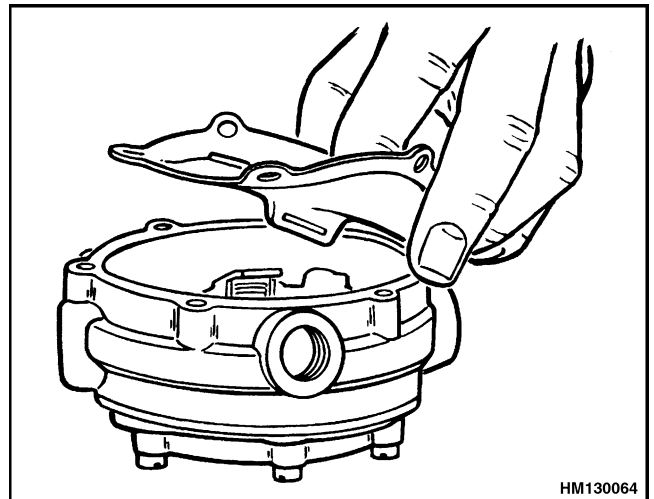


**STEP 8.**

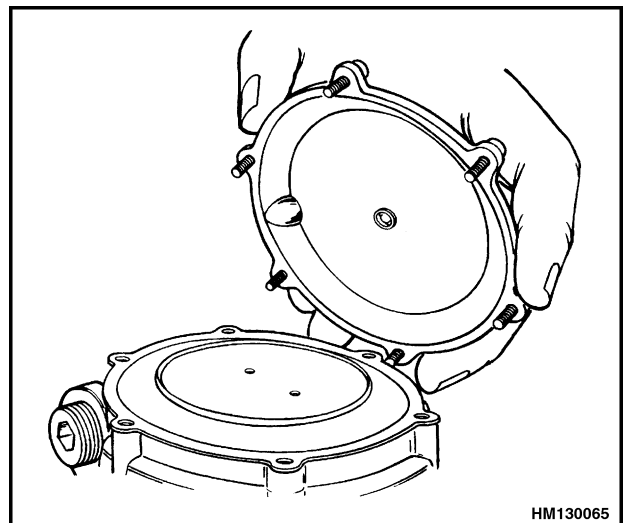
Tighten the screw. Make sure the lever moves freely.

**STEP 9.**

Slide the lever into the slot in the diaphragm bracket. Install the diaphragm.

**STEP 10.**

Install the cover and tighten the screws.

**INSTALL**

**NOTE:** Use a liquid thread sealant on all fittings with threads at the vaporizer.

Install the mount capscrews. Connect all the lines to the fittings. Fill the radiator with coolant. Check for leaks.

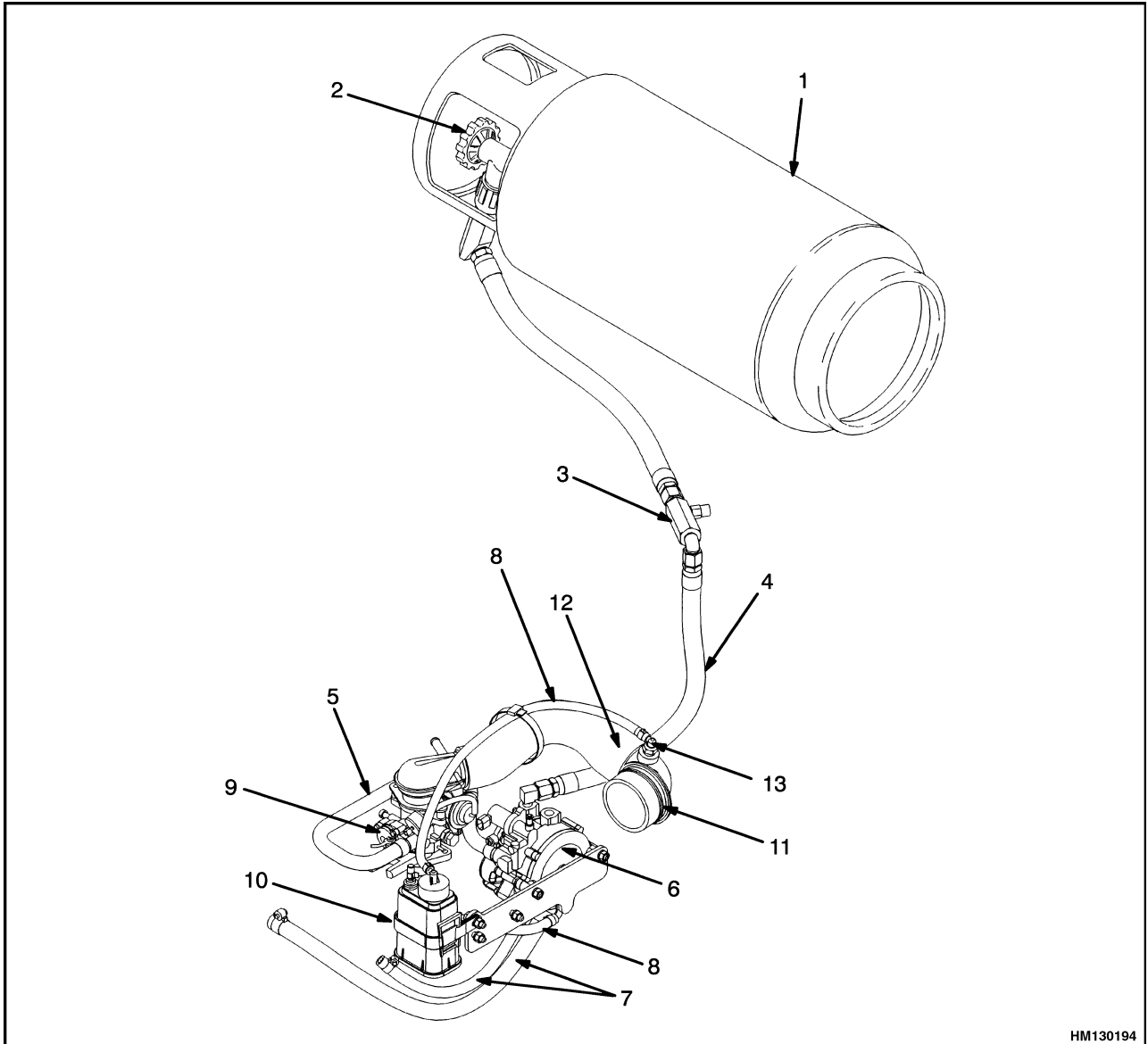
## General

This section has the description, operation, and repair procedures for the parts of the LPG fuel system used on the Mazda FE and F2 engines and the GM 3.0L engine.

## Description and Operation

The LPG fuel system has a fuel tank and valve, hydrostatic relief valve, regulator, carburetor, solenoid valve,

fuel pressure sensor and indicator lamp, and a governor. The LPG arrangement is shown in Figure 1.



HM130194

- |                    |                         |                                |
|--------------------|-------------------------|--------------------------------|
| 1. LPG TANK        | 6. REGULATOR/FILTER     | 11. AIR FILTER DISCHARGE ELBOW |
| 2. SHUTOFF VALVE   | 7. COOLING SYSTEM HOSES | 12. AIR INTAKE HOSE            |
| 3. RELIEF VALVE    | 8. VACUUM/BALANCE LINE  | 13. ORIFICE FITTING            |
| 4. LIQUID LPG HOSE | 9. LPG CARBURETOR       |                                |
| 5. LPG VAPOR HOSE  | 10. RESONATOR           |                                |

**Figure 1. Aisan LPG Open-Loop System**

PROBLEM	POSSIBLE CAUSE	PROCEDURE OR ACTION
Engine is hard to start. (Cont.)	Primary diaphragm on regulator is damaged.	Replace diaphragm.
	Idle mixture adjusting screw on regulator is out of adjustment.	Perform the adjustment procedures located in Regulator Adjustment.
Engine does not idle smoothly. (Lean fuel/air mixture)	Vacuum hose is either damaged or disconnected.	Replace damaged hose or connect hose that is disconnected.
	There is an air leak between carburetor and governor.	Replace gasket if it is broken or tighten mounting nuts to correct torque.
	There is tar accumulation in regulator.	Remove drain plug and drain tar from regulator.
	Fuel filter is clogged.	Replace fuel filter and clean tar from regulator.
	Main fuel shutoff solenoid valve is clogged.	Clean main fuel shutoff solenoid valve.
	Idle fuel shutoff solenoid valve is clogged.	Clean idle fuel shutoff solenoid valve.
	Idle mixture adjusting screw may be clogged with tar.	Clean or replace idle mixture adjusting screw as necessary.
	Power adjusting screw on carburetor is out of adjustment.	Perform adjustment procedures located in Carburetor Adjustment.
	Idle mixture adjusting screw on regulator is out of adjustment.	Perform adjustment procedures located in Regulator Adjustment.
Engine does not idle smoothly. (Rich fuel/air mixture)	Resonator hose is disconnected or damaged.	Connect resonator hose or replace resonator hose.
	Resonator is damaged.	Replace resonator.
	Power adjusting screw on carburetor is out of adjustment.	Perform adjustment procedures located in Carburetor Adjustment.
	Idle mixture adjusting screw on regulator is out of adjustment.	Perform adjustment procedures located in Regulator Adjustment.

4. Install seal, fuel injector, and two screws on carburetor.
5. Install idle air bypass adjusting screw into carburetor until screw is seated. Unscrew idle air bypass adjusting screw the number of turns specified for the engine in the lift truck. See Table 1.

**Table 1. Adjusting Screw**

Engine	FE	F2	GM
Number of Loosening Turns	1	1	1

6. Using two screws, install idle-up diaphragm on carburetor.
7. Install diaphragm (as noted during removal), spring, cover, and three screws. Tighten screws to 1.5 to 2.0 N•m (13 to 18 lbf in).

## INSTALL

1. Install new gasket on governor. See Figure 1. Install carburetor on governor.
2. Connect power valve hose.
3. Connect hose from carburetor (spark advance port) to distributor.
4. Connect hose to idle control actuator.
5. Connect both fuel inlet hoses (large hose to carburetor and smaller hose to fuel injector).
6. Connect hose from air cleaner to bonnet.
7. Connect throttle cable at carburetor. Check and adjust throttle linkage as described in Throttle Linkage Adjustment.

## Fuel Injector Repair

### REMOVE

1. Turn shutoff valve clockwise until valve is completely closed. See Figure 11.
2. Run engine until it stops, then turn key to **OFF** position.
3. Disconnect hose from fuel injector.
4. Remove two mounting screws. Remove fuel injector and seal from carburetor.

### CLEAN AND INSPECT

1. Use a clean cloth to remove any carbon deposits around nozzle.



### WARNING

Compressed air can move particles so that they cause injury to the user or to other personnel. Make sure that the path of the compressed air is away from all personnel. Wear protective goggles or a face shield to prevent injury to the eyes.



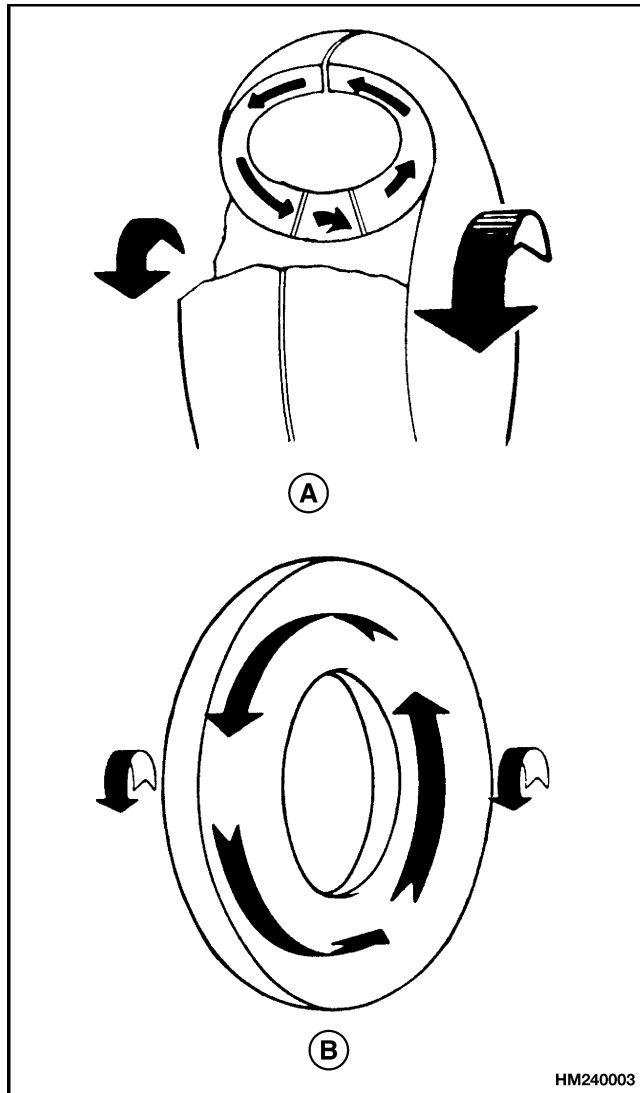
### CAUTION

Do not insert wire more than 2.0 mm (0.08 in.) into fuel injector nozzle. Otherwise, internal parts of fuel injector may be damaged.

2. Use a 1.2 mm (0.05 in.) diameter piece of steel wire to clean out inside of nozzle. Insert and pull out wire approximately 10 times while adding 343 to 490 kPa (50 to 71 psi) of pressure through fuel supply port.
3. Use an ohmmeter to check fuel injector coil for continuity. The coil resistance should be 3.5 to 4.5Ω.
4. Apply 12 VDC to both connector terminals of fuel injector. A clicking sound should be heard.

## INSTALL

1. Insert seal and fuel injector into carburetor.
2. Install two mounting screws. Tighten screws to 6.4 to 7.9 N•m (57 to 70 lbf in).
3. Connect hose to fuel injector.

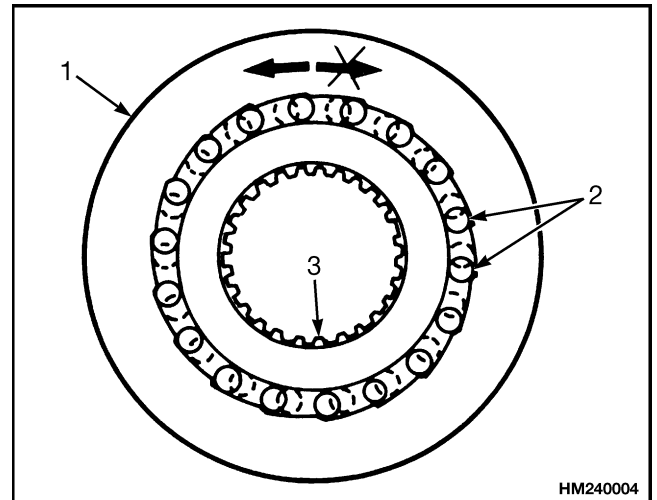


A. VORTEX FLOW      B. ROTARY FLOW

**Figure 3. Flow Types**

The stator is between the turbine and impeller in the center of the torque converter. When the oil hits the stator blades, the stator clutch prevents the stator from turning in the direction opposite of engine rotation. The blades of the stator change the direction of the oil so that the oil enters the impeller in the direction of engine rotation. See Figure 4. The energy that remains in the

oil flow as it leaves the stator is added to the new energy being added to the impeller by the engine. This use of energy, controlled by the stator, permits the torque converter to multiply the torque of the engine.



1. OUTER RACE      3. SPLINES ON INNER RACE  
2. ROLLERS

**Figure 4. Stator Clutch**

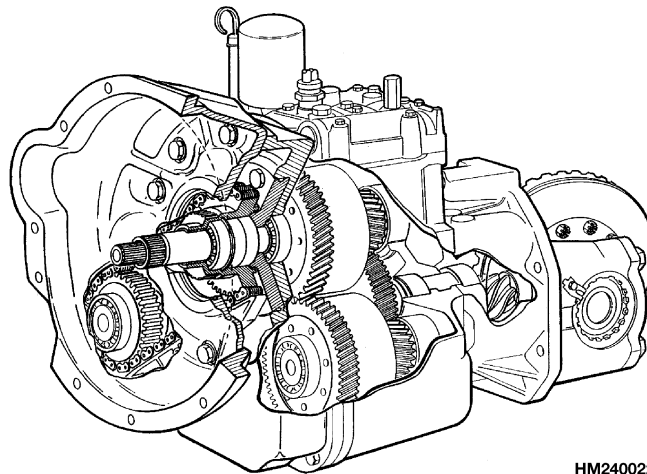
Resistance to the flow of oil in the turbine, because of centrifugal force, increases as the speed of the turbine increases. This resistance decreases the energy and amount of oil flow to the impeller from the stator. When the flow to the impeller decreases, the additional force added to the impeller decreases. Less torque is generated when less torque is needed.

When the lift truck is traveling at a constant speed on level ground, the turbine and impeller rotate at approximately the same speed. See Figure 5. The centrifugal force of the oil is the same for both the impeller and turbine. The oil does not flow through the stator, and torque is not multiplied. The rotating oil hits the back of the stator blades and turns the stator in the direction of engine rotation. The stator clutch permits the stator to turn with engine rotation. The impeller, turbine, stator, and oil rotate as a unit when torque multiplication is not required.

# SINGLE-SPEED POWERSHIFT TRANSMISSION

## TROUBLESHOOTING AND REPAIR

GP/GLP/GDP2.00-3.00RF/TF  
(GP/GLP/GDP040-060RG/TG/ZG) [A875];  
GC/GLC040-065RG/TG/ZG [E187]

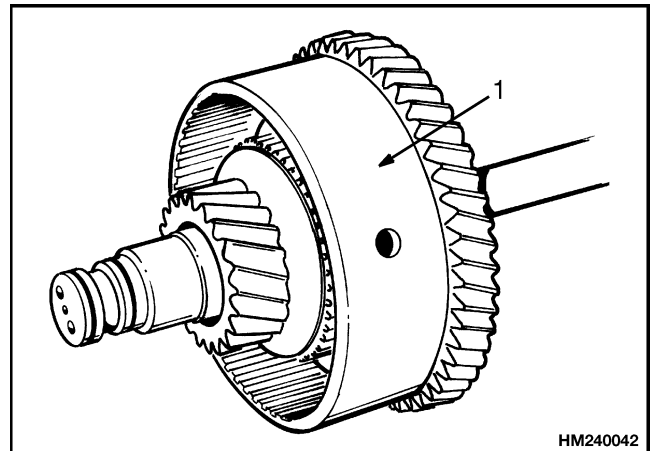


HM240022

**NOTE:** Make sure the orientation of the thrust needle bearing and the snap ring is the same as shown in the arrangement in STEP 4.

**STEP 5.**

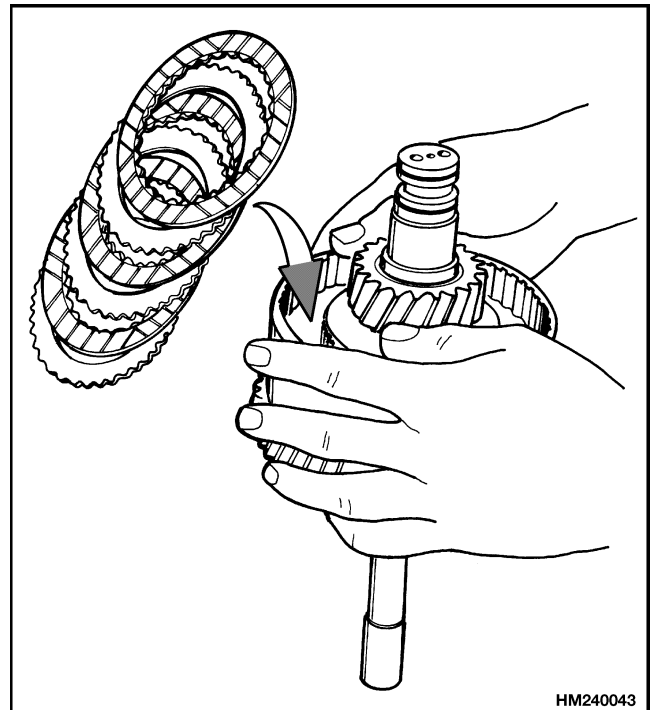
Install the output gear on the clutch shaft. Install the second thrust washer and thrust needle bearings. For lift trucks with Exedy clutch packs, there is only one thrust needle bearing and it is installed with the smooth side against the needle bearing (output gear). Install the snap ring. See the thrust washer and thrust bearing arrangement in STEP 4.



1. OUTPUT GEAR

**STEP 6.**

For lift trucks with Exedy clutch assemblies, install the conical plate (see Figure 12). When installing the conical plate, be sure the cone side fits against the piston. For all lift trucks, install the separator plates and friction discs. Begin with a separator plate against the piston and finish with a friction disc against the pressure plate.



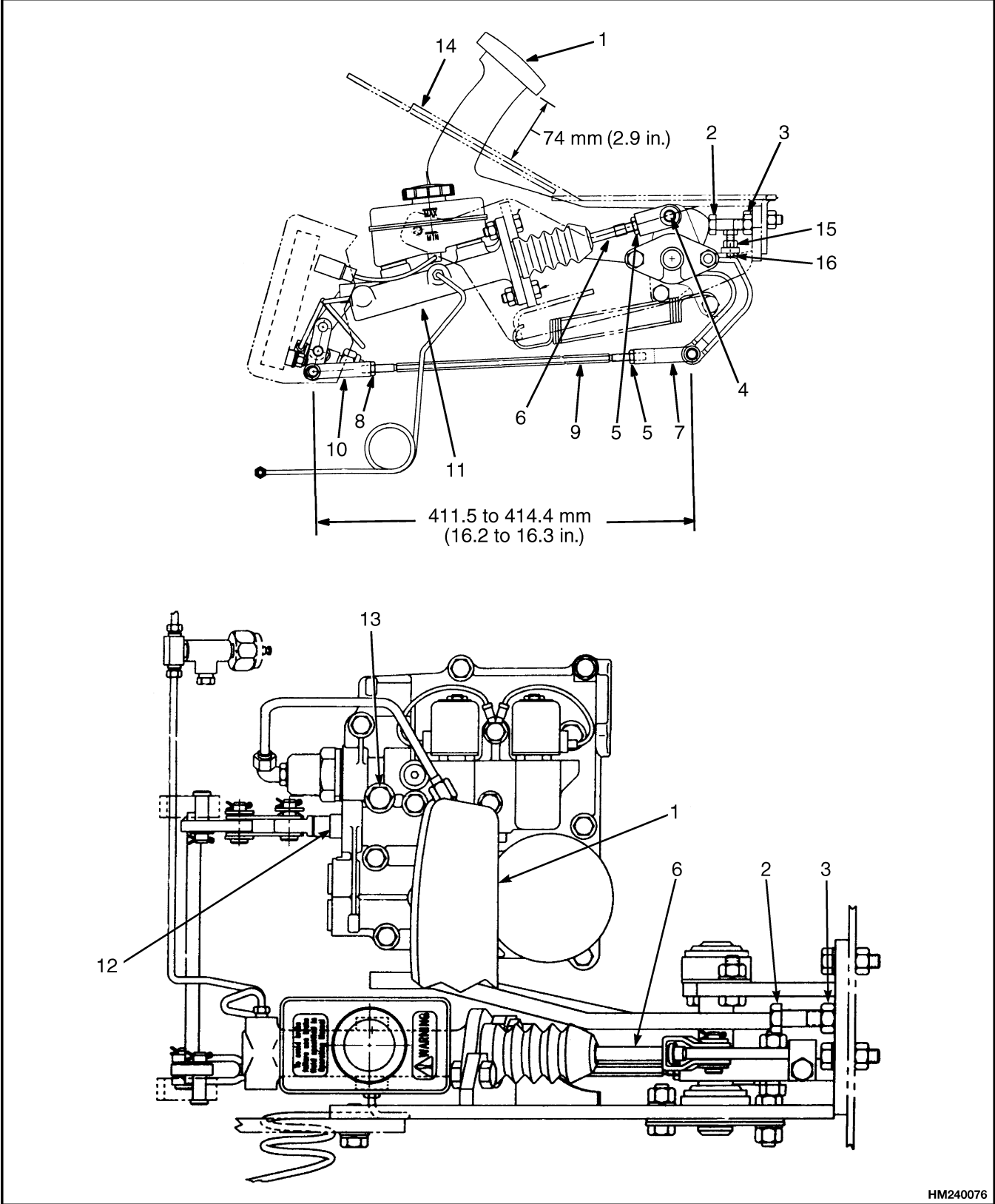
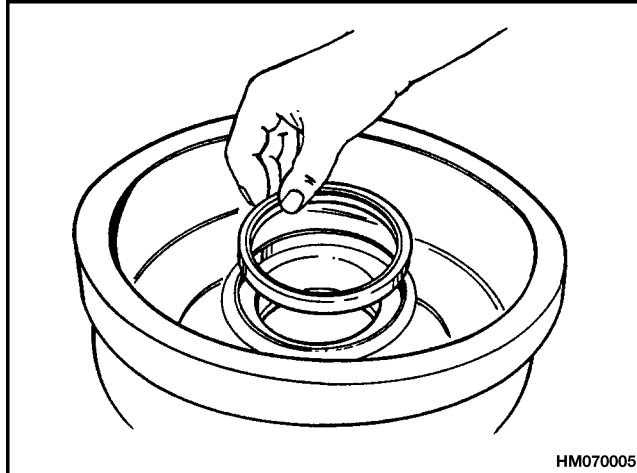
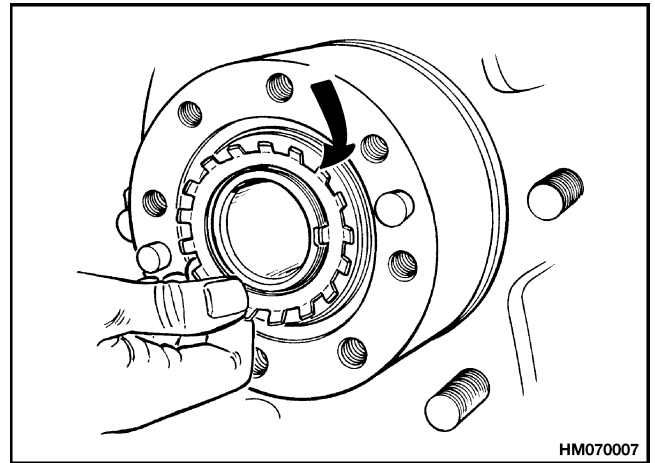


Figure 40. Inching/Brake Pedal Adjustment GC040-065TF/RF



*Figure 6. Oil Seal Installation*



*Figure 7. Lock Plate Installation*

## Torque Specifications

### GP2.00-3.00RF/TF (GP040-060RG/TG/ZG)

#### Back Plate to Axle Mount Capscrews

225 N•m (166 lbf ft)

#### Wheel Cylinder Capscrews

18 to 27 N•m (13 to 20 lbf ft)

#### Spindle to Differential Housing

66 N•m (49 lbf ft)

#### Axle Shaft Capscrews

98 N•m (75 lbf ft)

#### Axle Mounts to Frame

325 to 380 N•m (240 to 280 lbf ft) Torque wrench on head of capscrew.

#### Wheel Nuts

490 to 510 N•m (361 to 376 lbf ft)

### GC040-065TF/RF

#### Back Plate to Axle Mount Capscrews

255 N•m (188 lbf ft)

#### Wheel Cylinder Capscrews

18 to 27 N•m (13 to 20 lbf ft)

#### Spindle to Differential Housing

90 N•m (66 lbf ft)

#### Axle Shaft Capscrews

90 N•m (66 lbf ft)

#### Axle Mounts to Frame

473 N•m (350 lbf ft) Torque wrench on nut.

#### Wheel Nuts

237 to 305 N•m (175 to 225 lbf ft)

## TABLE OF CONTENTS

General.....	1
Description .....	1
Operation.....	2
Steering Wheel and Column Assembly Repair .....	3
Assembly Components, Remove .....	3
Steering Control Unit, Disassemble .....	8
Steering Control Unit, Clean .....	8
Steering Control Unit, Assemble.....	8
Assembly Components, Install.....	10
System Air Removal .....	12
Troubleshooting .....	12

This section is for the following models:

ERC20-30AGF (ERC040-065RG/ZG) [E108];  
 ERC/P16-20AAF (ERC030-040AG/BG) [A814];  
 ERP20-30ALF [B216];  
 GC/GLC030-040AF [B809];  
 GLP/GDP16-20AF (GP/GLP/GDP030-040AF) [B810];  
 GP/GLP/GDP2.00-3.00RF/TF (GP/GLP/GDP040-060RG/TG/ZG) [A875];  
 GC/GLC040-065RG/TG/ZG [E187];  
 ERP20-30ALF (ERP040-060DH) [D216];  
 ERP20-32ALF (ERP040-065DH) [E216];  
 ERC/P16-20AAF (ERC030-040AH) [B814];  
 ERC20-32AGF (ERC040-065GH) [A908];  
 ERC35-55HG (ERC70-120HH) [B839/C839]

## General

This section has a description and the service procedures for the parts of the brake system. The brake system includes the following parts: master cylinder, brake shoes, wheel cylinders, inching/brake pedal and linkage, and parking brake system. A troubleshooting section is included at the end of this section.

## Description and Operation

### SERVICE BRAKES

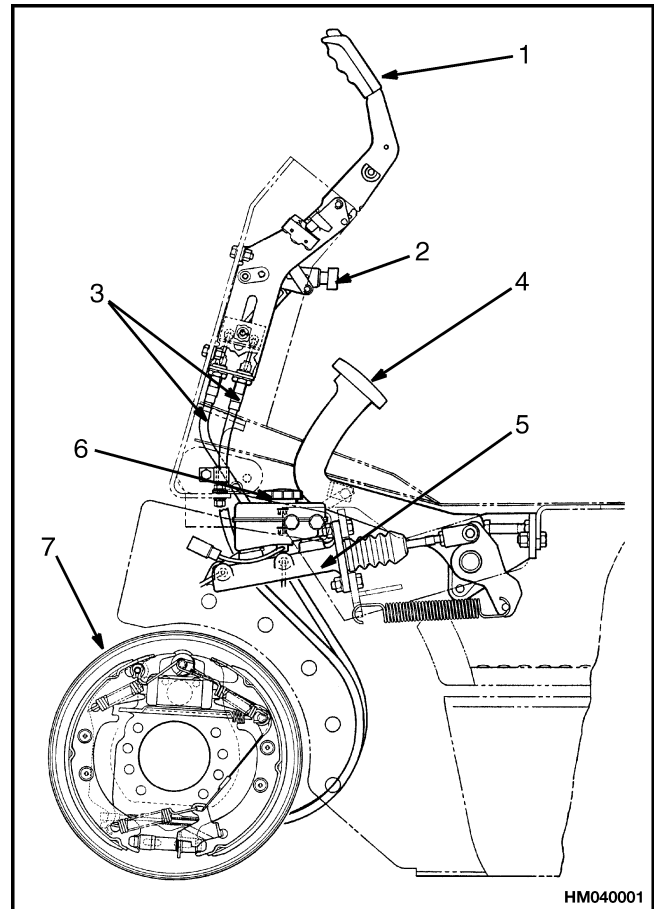
A service brake assembly is installed on the mounts at each end of the drive axle. See Figure 1. The parts of the service brake assembly are shown in Figure 4. When the brake pedal is pushed, fluid pressure from the master cylinder causes the pistons in the wheel cylinder to extend. The pistons expand the brake shoes against the drums.

The clearance between the brake shoes and the brake drum is adjusted automatically. An adjuster linkage turns the adjuster wheel to adjust the clearance. When the lift truck moves in the reverse direction and the brakes are applied, the rear brake shoe and the adjuster links move with the drum. This linkage moves the adjuster lever to rotate the adjuster wheel. The adjuster wheel can turn only when there is clearance between the lining of the brake shoe and the brake drum. The adjuster wheel can also be turned with a tool. A slot in the back plate gives access to the adjuster wheel.

### MASTER CYLINDER

The master cylinder is designed for a dual-circuit system. The master cylinder has two separate pistons that operate in the single bore of the master cylinder. The reservoir for the fluid is pressed into the two ports on top of the master cylinder and held in position by seals. The operation of the master cylinder is as follows:

When the brakes are OFF, the hydraulic fluid can move freely between the dual-circuit system and the separate chambers of the fluid reservoir. See Figure 2.



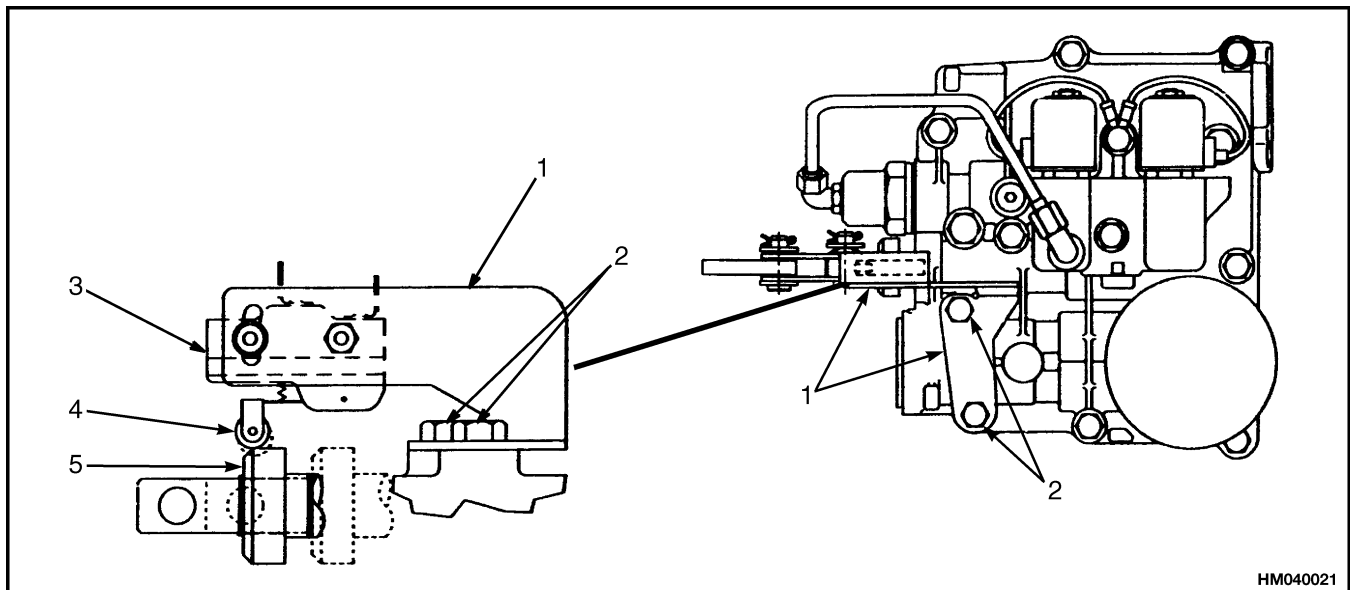
1. PARKING BRAKE LEVER
2. ADJUSTMENT KNOB
3. PARKING BRAKE CABLES
4. INCHING/BRAKE PEDAL
5. MASTER CYLINDER
6. BRAKE FLUID RESERVOIR
7. BRAKE ASSEMBLY

**Figure 1. Brake System**

## Neutral Start Switch Adjustment, Foot Directional Control Pedal GC/GLC040-065RG/TG/ZG

**NOTE:** Before the neutral start switch is adjusted, make sure the adjustments for the clearance of the brake shoes and the inching/brake pedal overlap are correct.

1. Disconnect the wire harness from the neutral start switch. Connect an ohmmeter or other continuity checker to the switch contacts.
2. Loosen the nuts that fasten the switch to the bracket. Loosen the capscrews that fasten the bracket to the control valve. The switch and the bracket must move freely.
3. Move the inching spool of the control valve to the fully extended position.
4. Adjust the switch bracket so that the roller of the switch is on the forward corner of the disc of the inching spool. See Figure 16. Tighten the capscrews that fasten the bracket without moving the bracket. Tighten the capscrews to 19 N•m (14 lbf ft).
5. Slowly rotate the neutral start switch down until the meter indicates that the switch contacts close. Hold the switch in this position and tighten the nuts so that the switch cannot move. Connect the wire harness connectors to the switch contacts.



- |                         |                       |
|-------------------------|-----------------------|
| 1. SWITCH BRACKET       | 4. SWITCH ROLLER      |
| 2. BRACKET CAPSCREWS    | 5. NEUTRAL START DISK |
| 3. NEUTRAL START SWITCH |                       |

**Figure 16. Neutral Start Switch Adjustment (Foot Directional Control Only)**

**ASSEMBLE AND INSTALL**

1. Put oil on all parts of the pump and valves. Use the hydraulic oil shown in the **Periodic Maintenance** section. Make sure to keep the parts clean. See Figure 3, Figure 4, Figure 5, and Figure 7.
2. Install the bottom plug and O-ring for the regulator plunger. See Figure 5. Install the orifice in the regulator plunger. Install the spring and regulator plunger in the housing. Install the O-ring and plug at the top of the housing.
3. Install the O-rings on the relief valve housing. See Figure 5. Install the relief valve housing in the valve end housing. Install the relief valve poppet and spring. Install the O-ring, adjuster, and lock nut. Do not tighten the adjuster or lock nut until the setting is adjusted as described in Steering Relief Pressure Check and Adjustment.
4. Use new seals and install the pressure plates, bushings (on newer models), and gears. Make sure to install the pressure plates as removed during disassembly. See the notes made during disassembly. Make sure all seals are complete and in the correct positions.
5. Make sure the dowels are installed in the end that has the drive shaft and on the side that has the inlet.

Install a new oil seal in the flange end housing. Put tape on the drive shaft splines and carefully install the flange end housing. Do not move the pressure plates. Make sure the seals do not move out of the correct position.

6. Carefully install the valve end housing on the pump body using the four capscrews and lockwashers. Make sure the pressure plates do not move and that the seals stay in the correct position. Make sure the marks made during disassembly are aligned. Tighten the capscrews to 46 to 49 N•m (34 to 36 lbf ft).
7. Put a liquid gasket material on the pump flange. Hold the pump in the correct position on the engine. Install the capscrews and washers that fasten the pump to the transmission housing.
8. Connect the hydraulic lines as shown by the tags. Do not tighten the inlet fitting. Fill the tank using the hydraulic oil shown in the **Periodic Maintenance** section. Let some of the oil run out around the pump inlet fitting. Tighten the fittings. This procedure will make sure the pump has oil for first operation.
9. Adjust the steering relief setting as described in Steering Relief Pressure Check and Adjustment.

**Steering Relief Pressure Check and Adjustment**

**NOTE:** Adjust the relief pressure for the lift and tilt system as described in the section for the **Main Control Valve** 2000 YRM 516.

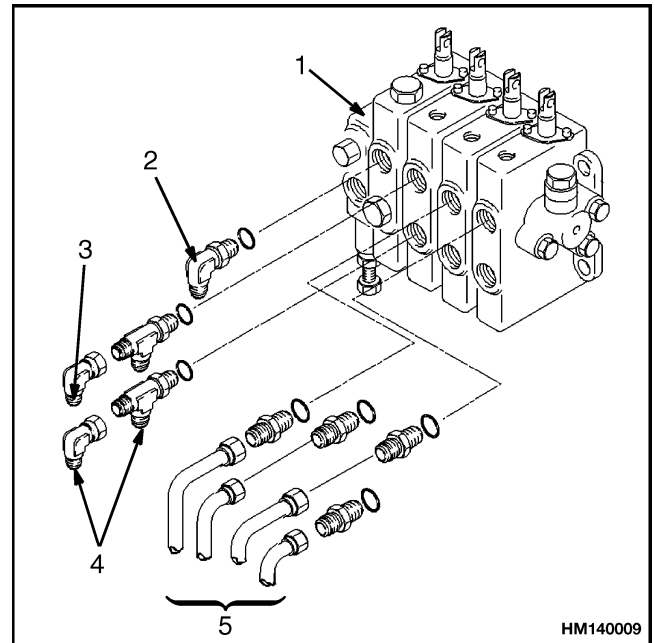
1. Connect a tachometer to the engine. See Figure 1 and Figure 6.
2. Connect a gate valve and pressure gauge to the test port located at the tee fitting. The tee fitting is on the inlet line near the steering control unit.
3. Operate the engine at 700 rpm. Operate the hydraulic system until the oil temperature is 55 to 65°C (130 to 150°F). Turn the steering wheel to the stop and hold it in that position.
4. Check the gauge. The correct pressure is 10.6 to 11.7 MPa (1540 to 1700 psi).
5. If the pressure is less than the specifications, loosen the lock nut and turn the adjuster for the relief valve clockwise. See Figure 6. If the pressure is higher than the specification, turn the adjuster counterclockwise. After the setting is correct, hold the adjuster and tighten the lock nut.
6. Remove the pressure gauge, gate valve, and tachometer. Install the test port cap.

**Legend for Figure 8**

- |                        |                                       |
|------------------------|---------------------------------------|
| 1. INLET SECTION       | 12. END CAP                           |
| 2. O-RING              | 13. CHECK VALVE                       |
| 3. RELIEF VALVE (LIFT) | 14. SPOOL END                         |
| 4. PLUG                | 15. TILT CONTROL SPOOL                |
| 5. LIFT/LOWER SPOOL    | 16. TILT SPOOL                        |
| 6. SEAL                | 17. TILT SECTION                      |
| 7. RETAINER            | 18. AUXILIARY SPOOL                   |
| 8. LIFT/LOWER SECTION  | 19. AUXILIARY SECTION                 |
| 9. SPRING CUP          | 20. RELIEF VALVE (TILT AND AUXILIARY) |
| 10. SPRING             | 21. OUTLET SECTION                    |
| 11. SCREW              | 22. THROUGH-BOLT                      |

**INSTALL**

1. Install the control valve on the frame bracket. Install the bracket and control valve on the frame of the lift truck. See Figure 6 and Figure 7. Install the side strut to the frame.
2. Install the link pins and cotter pins in the control valve spools.
3. Install the linkage assembly. See Figure 6 and Figure 7. Connect the side strut and end plates. Install the spring for the control lever with the detent. Check the operation of the levers. Make sure the levers operate as described at the front of this section.
4. Connect the hydraulic lines to the control valve. See Figure 9.
5. Install the cover tray to the mount plate. See Figure 6 and Figure 7. Make sure the cover trays fit over the edges of the boot. Adjust the cover trays as necessary so that they fit in the opening of the hood.
6. Add the hydraulic oil to the tank. See the section **Periodic Maintenance** for your lift truck for the correct specifications.
7. Operate the system and check for leaks and correct operation. Adjust the relief valves as described in Pressure Relief Valve Check and Adjustment.



1. MAIN CONTROL VALVE
2. TO/FROM LIFT CYLINDERS
3. TO/FROM PISTON END OF TILT CYLINDERS
4. TO/FROM ROD END OF TILT CYLINDERS
5. TO/FROM ATTACHMENT CYLINDERS

**Figure 9. Hydraulic Line Arrangement**

### Digital Display

The four-digit, digital display on the right side of the instrument panel is the display for the traction hourmeter, lift pump hourmeter, and the status codes. The hourmeter and traction motor indicators will be **ON** when the display shows hours of operation of the traction system. The hourmeter and lift pump motor indicators will be **ON** when the display shows hours of operation of the hydraulic system. The status code indicator will be **ON** when the display shows status codes.

### Status Codes Push Button

Push and hold the push button to display all the status codes in the memory for detected faults of the traction system. The traction motor indicator will be **ON** to show that the status codes are for the traction system. If the push button is released and then pushed and held again, the digital display will start over showing all the status codes for the traction system. Push the button twice and hold the push button to display all the status codes in the memory for detected faults of the lift system. The lift pump motor indicator will be **ON** to show that the status codes are for the lift system. If the push button is released and then pushed twice and held again, the digital display will start over, showing all the status codes for the lift system.

### Performance Level Indicators

These indicators show the performance level set by the operator by the push button under them. There are four possible performance levels available from the slowest (left indicator - turtle) to the fastest (right indicator - rabbit). See Figure 5.

### Performance Level Push Button

This push button sets the performance level of the lift truck as follows:

- Level 1 - Low performance for handling fragile loads.
- Level 2 - Medium level for more economy of battery charge.
- Level 3 - Higher level for faster load handling, but less economy.
- Level 4 - Maximum level for maximum performance operation.

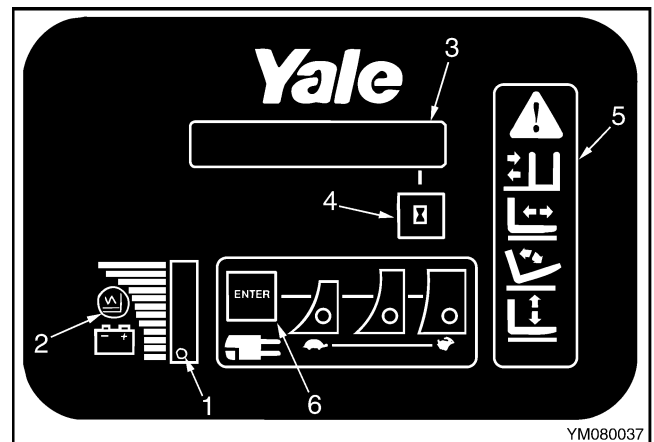
A service person can set all four levels to the same level setting.

## CURTIS 1215 DISPLAY PANEL

### Description and Features

**NOTE:** See the section **Battery Indicators** 2260 YRM 138 for a more complete description of the operation and the adjustment and repair procedures.

The Curtis 1215 display panel is a rectangular display unit that operates with the main interface board and the traction motor controller. See Figure 6. The panel is located in the front cover over the battery compartment of the NR/NDR030-045AD, NS040-050AE, and NR/NDR030-045CA lift trucks. It is used exclusively with the Curtis 1215 traction motor controller. For additional information, see the section **Traction Motor Controller and Handset** 2200 YRM 608.



1. BATTERY FUEL GAUGE INDICATOR
2. LOW BATTERY INDICATOR
3. LCD SCREEN
4. DISPLAY MODE (SWITCH 1)
5. HYDRAULIC FUNCTION INDICATORS
6. DRIVE MODE (SWITCH 2)

**Figure 6. Curtis 1215 Display Panel**

Two different versions of the display panel are available, depending on ambient temperature.

Standard models	–25 to 70°C (–13 to 158°F)
Freezer models	–40 to 70°C (–40 to 158°F)

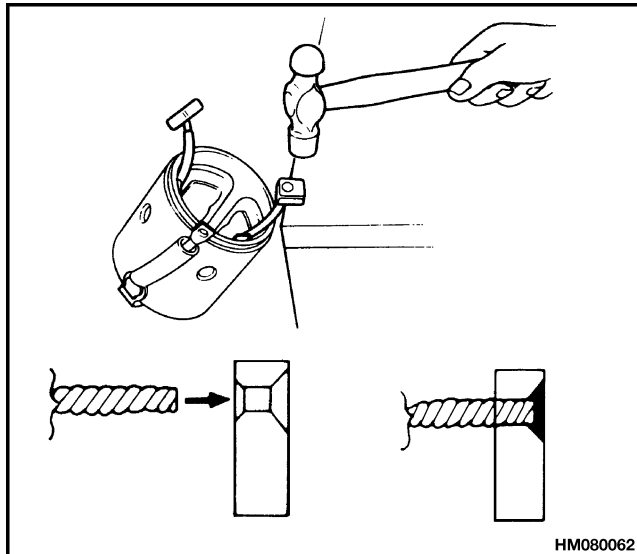


Figure 5. Starter Motor Brushes

**Legend for Figure 5**

**NOTE:** USE A HAMMER TO BREAK BRUSH FROM WIRE.

**NOTE:** USE A SOLDERING IRON TO REMOVE OLD SOLDER FROM WIRE. TWIST END OF BRUSH WIRE TO PUT WIRES TOGETHER. PUT WIRE IN BRUSH AND SOLDER BRUSH TO WIRE. MAKE SURE SOLDER SURFACE ON BRUSH IS FLAT.

## Coil Replacement



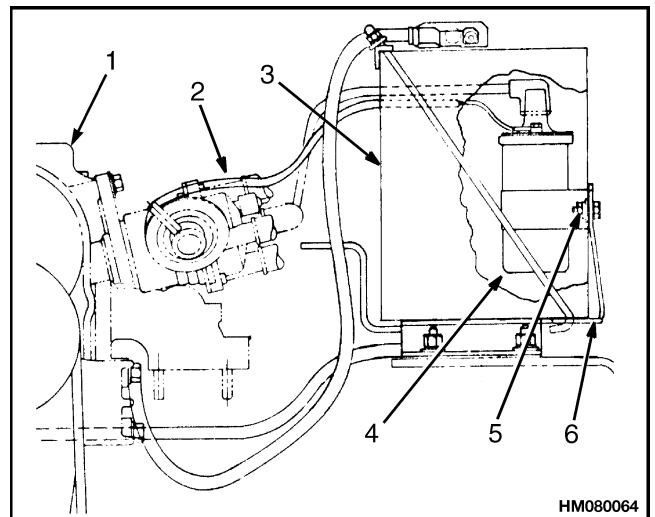
### WARNING

Always disconnect the battery ground cable before making repairs to prevent possible damage and injury. Install a tag on the battery terminal so that no one connects the cable on the terminal.

**NOTE:** Use the Troubleshooting, General Checks and Adjustments, Starter Checks, Ignition System Check and Adjustment, and Charging Circuit Checks of this section before starting any repair procedures. Make sure repair or replacement of the part is necessary before removal, disassembly, or replacement of the part.

The coil is installed on a bracket near the battery tray.

1. Put labels on wires connected to coil for correct connection during installation. See Figure 6.
2. Remove two capscrews, nuts, and washers that fasten coil to battery bracket.
3. Install replacement coil using capscrews, nuts, and washers.
4. Connect all wires to coil as marked on labels.



**NOTE:** GC/GLC040-065RG/TG/ZG SHOWN.

1. ENGINE
2. DISTRIBUTOR
3. BATTERY
4. IGNITION COIL
5. SCREW, NUT, AND WASHER (2)
6. BATTERY BRACKET

Figure 6. Coil Replacement

## General

This section describes the operation of the Micro-processor Spark Timing System (MSTS). The MSTS ignition system is used on engines that use an LPG fuel system. Distributor Repair, Ignition Module Replacement, Ignition Coil Replacement, MSTS Module

Replacement, ECT Sensor Replacement, MAP Sensor Replacement, and Troubleshooting procedures are also in this section.

## Description

The general operation of the MSTS system is described in the following paragraphs. The description of the components and a circuit analysis is given in the paragraphs under Operation.

### WHAT MSTS DOES

The MSTS module receives signals from sensors mounted on the engine and electronically processes the information to adjust the ignition timing for the best fuel use and engine performance. See Figure 1.

The MSTS module receives signals from the following sensors:

- Manifold Absolute Pressure (MAP) sensor. This sensor is a pressure transducer that measures the atmospheric pressure before the engine is started. The MSTS module uses this pressure as a reference. This sensor then measures changes in pressure in the intake manifold during engine operation.
- Engine Coolant Temperature (ECT) sensor. This sensor is a thermistor (resistor that is calibrated to change its value as its temperature changes).
- The ignition module is a small electronic module within the distributor. This module is a signal converter that senses the operation of the distributor. A sensing coil in the distributor senses the rotation of the timer core, and the ignition module senses the speed of rotation. A square wave generator in the ignition module converts the pulses from the sensing coil to a square wave signal that is sent to the MSTS module. If the signals from the ignition module to the MSTS indicate that the engine is rotating at less than 400 rpm, the MSTS module determines

that the engine is being rotated by the starter. The ignition module controls the ignition for an engine being started. The Electronic Spark Timing (EST) function from the MSTS module is de-energized. If the signals from the ignition module to the MSTS module indicate that the engine is rotating at greater than 400 rpm, the MSTS module determines that the engine is running and the (EST) controls the ignition.

### HOW MSTS BEGINS OPERATION

When the ignition switch is turned to **ON**, the MSTS module measures the atmospheric pressure (BARO signal) from the MAP sensor. The MSTS module also checks the signal from the ECT. When the starter is engaged, the ignition module sends electronic pulses to the MSTS module. The frequency of the pulses indicates to the MSTS module that the engine is being started. The ignition module also electronically energizes (**ON**) and de-energizes (**OFF**) the primary circuit of the ignition coil to create a spark at the spark plugs.

When the engine starts, the frequency of the pulses from the ignition module increases and indicates to the MSTS module that the engine is running. The MSTS module then sends a bypass signal to the ignition module that removes control of the spark (ignition) timing from the ignition module. The MSTS module takes control of the ignition timing and follows its program to give ignition timing for the best engine operation. When the engine is operating, the MSTS module continuously checks the signals from the MAP, ECT, and distributor speed to make timing adjustments for the engine operating conditions.

3. Use the vacuum pump to apply 34 kPa (10 inHg) of vacuum to the MAP sensor. See Table 3. Look at the voltage change indicated on the voltmeter. The voltage change will normally occur as quickly as the vacuum is applied to the MAP sensor.
4. Compare the voltage indicated on the voltmeter with the voltage indicated in Test 1, Step 6. The correct voltage indicated in this step will be 1.2 to 1.3 volts less than the voltage indicated in Test 1, Step 6.
5. If the voltage signals are correct, check for vacuum leaks in the hoses and connections. If the voltage signals are not correct, replace the MAP sensor.

## ENGINE COOLANT TEMPERATURE (ECT) SENSOR

**NOTE:** This troubleshooting is normally used only if there is a problem when the engine coolant is cold. A fault in the ECT normally causes a problem before the engine coolant has increased to operating temperature. The problem can be a short delay when the throttle is opened or a decrease in engine power.

### Circuit Description

The ECT sensor uses a thermistor to control the signal voltage to the MSTS module. See Figure 16. The

MSTS module (terminal **G**) applies a 5-volt reference voltage to the ECT. When the engine coolant is cold, the thermistor resistance is higher than when the engine coolant is at operating temperature. As the temperature of the engine coolant increases after the engine is started, the resistance decreases and the signal voltage decreases. When the engine is operating at 85 to 95°C (185 to 203°F), the signal voltage is approximately 1.5 to 2.0 volts.

### Test Description

The bold numbers on the troubleshooting chart have the following indications (see Figure 17):

1. This step checks if there is a fault in the wiring or the MSTS module or if the fault is in the ECT.
2. Make sure the electrical connections do not have dirt and corrosion. If an ohmmeter is connected across terminals **A** and **B** of the ECT, the resistance normally decreases as the temperature of the engine coolant increases.
3. This step checks if there is a fault in the wiring to the ECT or the sensor ground.

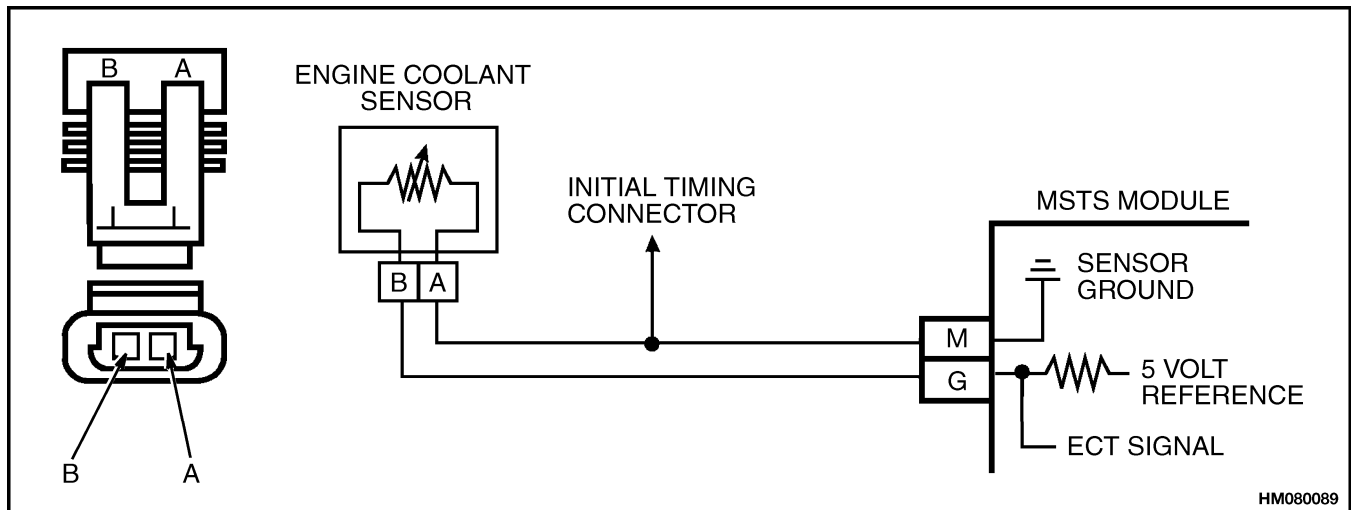


Figure 16. ECT Sensor Troubleshooting

Table 2. SCAN Tool Information

<b>Test under following conditions: Idle speed, upper radiator hose hot, throttle closed, NEUTRAL, all accessories OFF</b>		
<b>SCAN Position</b>	<b>Units Displayed</b>	<b>Values</b>
Engine Speed	rpm	+100 rpm from
Idle Speed	rpm	ECM idle command (changes with temperature)
Coolant Temp.	°C (°F)	85 to 100°C (185 to 212°F)
Ignition Volts	volts	12.5 to 14.5 V
MAP	Volts/kPa	1 to 2 (depends on Vac. and BARO pressure), 30-40 kPa
BARO	Volts/kPa	1 to 2 (depends on BARO pressure), 98-102 kPa
Throttle Position	volts	0.45 to 1.25 V
Throttle Angle	0 to 100%	0
Governor TPS	0 to 100%	0
Desired Governor TPS	0 to 100%	0
Governor Enable	Yes/No	Yes
Governor rpm Control	Active/Not Active	Not Active
Governor rpm Mode	High rpm/Normal	Normal
Idle Air Control	Counts/Steps	Between 5 and 50
rpm Overspeed	Yes/No	No
Fuel Trim	Steps	N/A
Injector Pulse Width	mSec	0.8 to 3.0 mSec
Spark Advance	No. of Degrees	Varies
Base Timing	N/A	N/A
Knock Signal	Yes/No	No
Knock Retard	No. of Degrees	0 Degrees
Governor mph Control	Active/Not Active	Not Active
Vehicle Speed	mph	0 mph
mph Overspeed	Yes/No	No
Low Oil Pressure	Yes/No	No
Power Steering Switch	Normal/High	Normal
Emergency Stop	Active/Not Active	Not Active
Lift Mode	Active/Not Active	Not Active
EEPROM ID	Number	XXXX (varies with calibration) - 2201
Time From Start	hrs, min, sec	0:00:00 - 18:12:15

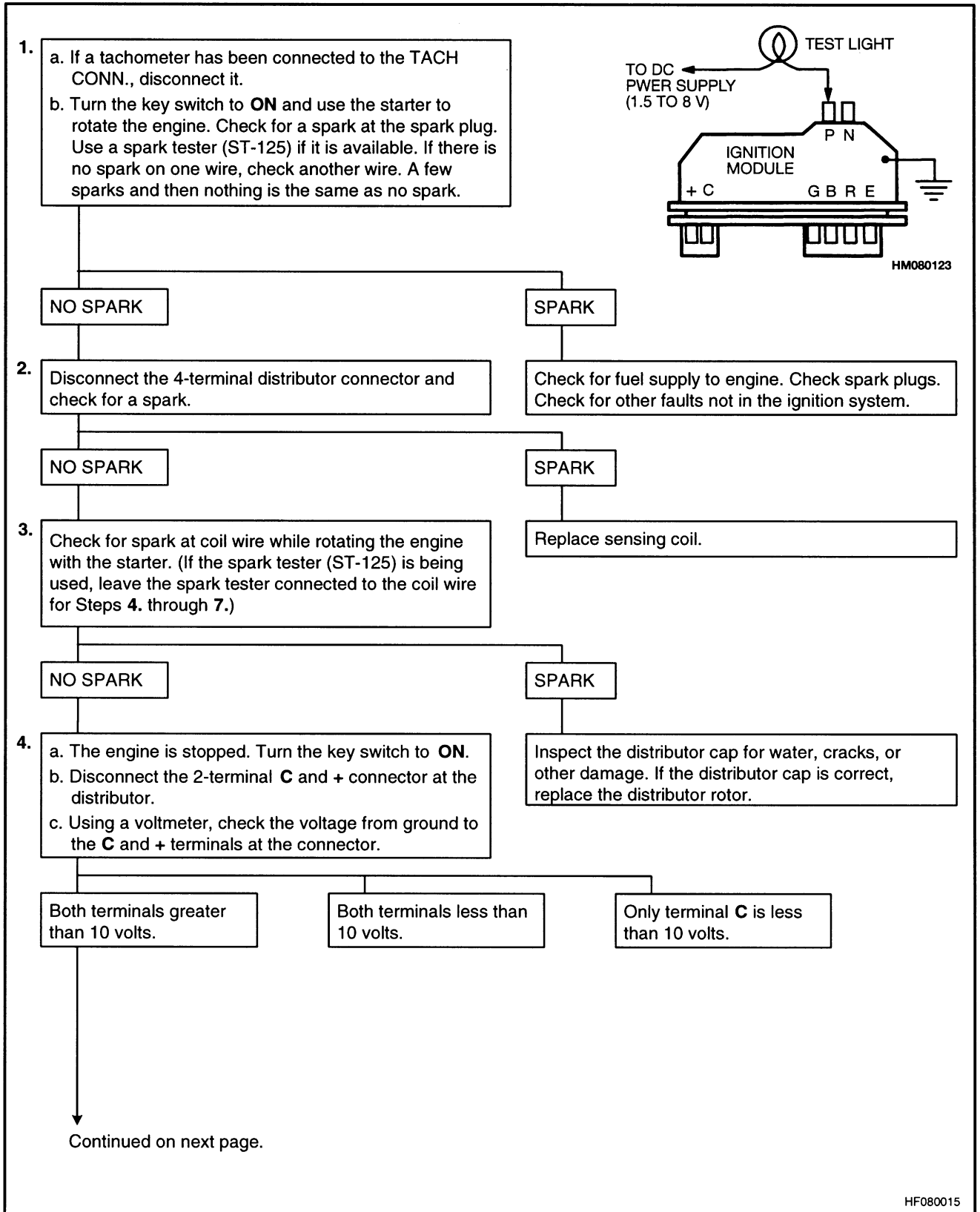


Figure 21. A-8 - Ignition System Troubleshooting (Sheet 1 of 2)

**IGNITION SYSTEM**

- Spark plugs for correct heat range.
- Ignition wires and cables for shorts or damaged insulation.

**ENGINE**

- For oil in the combustion chamber. Valve oil seals for leaking.
- Combustion chambers for excessive carbon buildup. Remove carbon with top engine cleaner using the instructions on can.
- Combustion chamber pressure by doing a compression test.
- Basic engine parts, such as cam, head, pistons, are not correct.

**COOLING SYSTEM**

- Problems from engine running too hot: - Low engine coolant level. - Loose water pump belt. - Restriction in airflow to radiator, or restriction in water flow through radiator. Correct coolant solution.

**FUEL SYSTEM**

To check if the condition is caused by a rich or lean system, test the vehicle under the same conditions in which the symptom occurs as described by the customer.

- Fuel pressure while condition exists. Use A-7 - Fuel System Troubleshooting.

**FAULT: ENGINE MOMENTARILY DOES NOT INCREASE POWER WHEN THROTTLE CHANGES****Definition:**

The engine momentarily does not increase power when the throttle is opened further. The engine can stop when the throttle is opened rapidly from idle.

**Check:**

Make a careful visual check as described in the earlier paragraphs.

- Engine thermostat operates correctly and at the correct heat range.
- Alternator output voltage. Repair if less than 9 or more than 16 volts.

**SENSORS**

- Throttle Position (TP) sensor. Check TP sensor for correct operation. Voltage will increase evenly as throttle is moved toward Wide Open Throttle (WOT).
- MAP sensor output.

**IGNITION SYSTEM**

- Dirty spark plugs or damaged secondary cables.
- Ignition system connection, circuit HX.

**FUEL SYSTEM**

- Fuel pressure. Use A-7 - Fuel System Troubleshooting.
- Dirty fuel.
- Low fuel pressure after a cold start or during acceleration. If fuel pressure drops below 62 kPa (9 psi), there can be a bad fuel pump or a restriction in the fuel system.

**GOVERNOR SYSTEM**

- Throttle cables.
- Governor motor.

**FAULT: ONE OR MORE CYLINDERS DO NOT OPERATE CORRECTLY. THE ENGINE DOES NOT IDLE CORRECTLY.****Definition:**

The operation of one cylinder is not regular, and the problem increases when the engine load increases. Problem normally does not occur above 1500 rpm. The engine has a rough idle or has a large variation in idle speed.

**Check:**

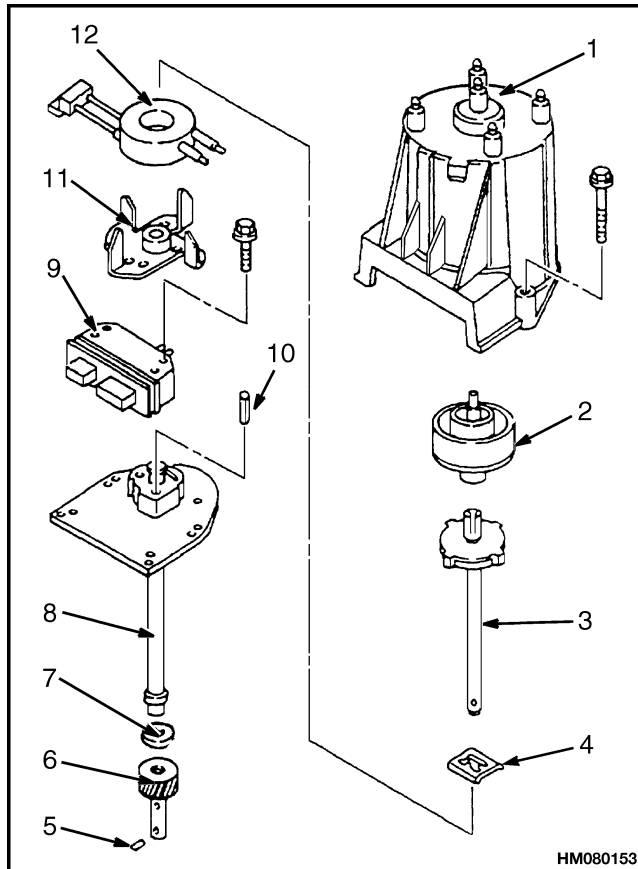
Make a careful visual check as described in the earlier paragraphs.

**IGNITION SYSTEM**

- Start engine, let engine become steady, then disconnect Idle Air Control (IAC) motor. Remove one spark plug cable at a time, using pliers with insulation. Be sure to connect the cable that was removed to ground while testing.
- If there is a decrease in rpm on all cylinders (equal to within 50 rpm), go to FAULT: Rough Idle Or Engine Stalls During Idle. Connect IAC valve.
- If there is no decrease in rpm on one or more cylinders, check for spark on the cylinder(s) using an oscilloscope or spark tester. Check one spark plug cable at a time. If no spark, see SYSTEM TEST CHARTS. If there is a spark, remove spark plug(s) in these cylinders and check for:
  - Cracks in the insulator, wrong gap, burned electrodes, or wear.
  - Spark plug cables by connecting ohmmeter to ends of each cable in question. If meter reads over 30,000 ohms, replace cable(s).

## Disassemble

1. Remove the rotor. See Figure 61. Make a match-mark on the gear and the shaft so they can be assembled in the same position.



- |                     |                   |
|---------------------|-------------------|
| 1. CAP              | 7. SEAL           |
| 2. ROTOR            | 8. HOUSING        |
| 3. SHAFT/TIMER CORE | 9. MODULE         |
| 4. RETAINER         | 10. ALIGNMENT PIN |
| 5. PIN              | 11. POLE PIECE    |
| 6. DRIVE GEAR       | 12. COIL          |

**Figure 61. Distributor**

2. Use a punch to remove the roll pin (5) from the shaft.
3. Remove the gear.
4. Remove the shaft with the timer core from the housing.
5. Remove the retainer from the housing. Use a screwdriver as a pry bar.

6. Disconnect the sensing coil from the ignition module.



## CAUTION

Carefully lift and release the lock tab on the connector to the sensing coil. The lock tab can be easily broken if too much force is applied with a screwdriver or other tool.

7. Use a screwdriver to lift the lock tab. Remove the sensing coil.
8. Remove the two screws that hold the ignition module in the housing. Remove the ignition module.

## Inspect

1. Inspect the shaft for a loose fit between the shaft and its bushing in the housing. If the bushing or the shaft is worn so that the shaft moves from side to side in the bushing, replace the shaft or the housing.
2. Inspect the housing for cracks or damage.

## Assemble

**NOTE:** Yale Part No. 504069721 is a silicon bearing grease used between electronic components and their heat sinks. A small container of silicon grease is enclosed in the package with a new ignition module.

1. Apply silicon grease to the bottom of the ignition module. See Figure 61. Install the ignition module into the housing and tighten the two screws.
2. Install the sensing coil. The tab on the bottom of the sensing coil fits into the anchor hole in the housing.
3. Connect the sensing coil to the ignition module. Make sure the lock tab on the connector is fastened.
4. Install the retainer.
5. Install the shaft assembly into the housing.
6. Install the seal on the housing. Install the gear on the end of the shaft.
7. Align the marks on the gear and shaft. Install the roll pin (5). Turn the shaft assembly and make sure the teeth of the timer core on the shaft assembly do not touch the pole piece.

## TABLE OF CONTENTS

General.....	1
Description and Operation.....	1
General .....	1
Electronic Control Module (ECM).....	1
How ECM Begins Operation.....	3
Electronic Engine Control.....	3
What ECM Does .....	3
Distributor .....	4
Ignition Module .....	4
When the Engine is Being Started.....	5
When the Engine is Running .....	6
Electronic Control Module (ECM) Corrections.....	6
What the ECM Does .....	7
Fuel Control Operation.....	7
Starting Mode .....	7
Clear Excess Fuel (clear flood) Mode.....	7
Run Mode .....	8
Acceleration Mode .....	8
Deceleration Mode.....	8
Fuel Cutoff Mode .....	8
Fuel System Components.....	8
Fuel Pump Electrical Circuit.....	8
Throttle Body Injection .....	8
Throttle Position (TP) Sensor.....	8
Idle Air Control (IAC) Valve .....	9
Fuel Injector .....	10
Fuel Pressure Regulator.....	10
Idle Speed Control .....	10
Maximum RPM Control.....	10
Governor System .....	10
ECM Sensors and Controllers.....	11
Manifold Absolute Pressure (MAP) Sensor .....	11
Engine Coolant Temperature (ECT) Sensor .....	12
Positive Crankcase Ventilation .....	12

This section is for the following models:  
 GP/GLP/GDP2.00-3.00RF/TF (GP/GLP/GDP040-060RG/TG/ZG) [A875];  
 GC/GLC040-065RG/TG/ZG [E187]

The hang-on sideshift carriage lets the operator move the forks and load from side to side. This function makes it easier for the operator to align the forks with a load or align the load with a stack. The hang-on sideshift carriage hangs on the fork bars of the standard carriage. Special bushings fit between the hang-on sideshift carriage and the fork bars. A sideshift cylinder is installed on a plate that fits on the standard carriage. The sideshift cylinder moves the hang-on sideshift carriage on the standard carriage.

The integral sideshift carriage lets the operator move the forks and load from side to side. This function makes it easier for the operator to align the forks with a load or align the load with a stack. The integral sideshift carriage is a complete carriage and sideshift assembly. The sideshift cylinder moves the sideshift carriage on the standard carriage. See Figure 2.

## MAST MOUNTS

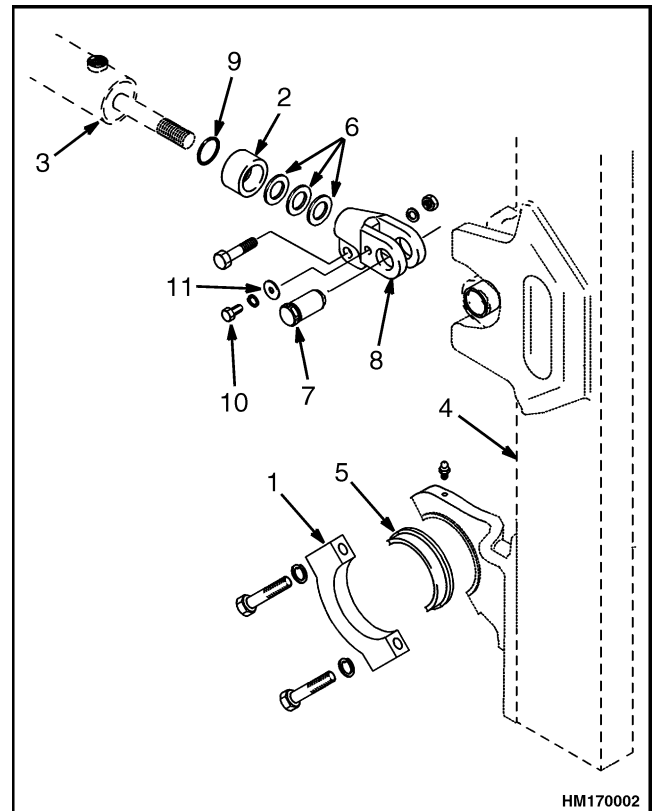
The mast can tilt forward and backward. Tilt cylinders are fastened between the frame of the lift truck and the outer mast weldment to change the angle of the mast and forks.

On GP/GLP/GDP16-20AF/BF (GP/GLP/GDP030-040AF/BF), GC/GCL030-040AF, GLP/GDP16-20AF (GP/GLP/GDP030-040AF), and EPC/P16-20AAF (ERC030-040AF, AG/BG) (A814), and ERC/P16-20AAF (ERC030-040AH) (B814) trucks, the mast pivots directly on the drive axle housing. The mounts are part of a casting that includes the lower crossmember for the outer channel. Each mount has a retainer cap that attaches the mast to the axle housing. Each mast mount uses one bushing. There are no bushings used in the retainer caps. See Figure 3.

On the ERP20-30ALF (B216), GC/GLC040-065RG/TG/ZG (E187), ERC20/25/30AGF (ERC040-065RF/ZF, RG/ZG) (E108), ERC20-32AGF (ERC040-065GH) (A908), GP/GLP/GDP20-30RF/TF (GP/GLP/GDP040-060RG/TG/ZG) (A875), and ERP20-30ALF (ERP040-060DH) (D216) trucks, pivot pins are installed in the drive axle hangers. The outer mast weldment has

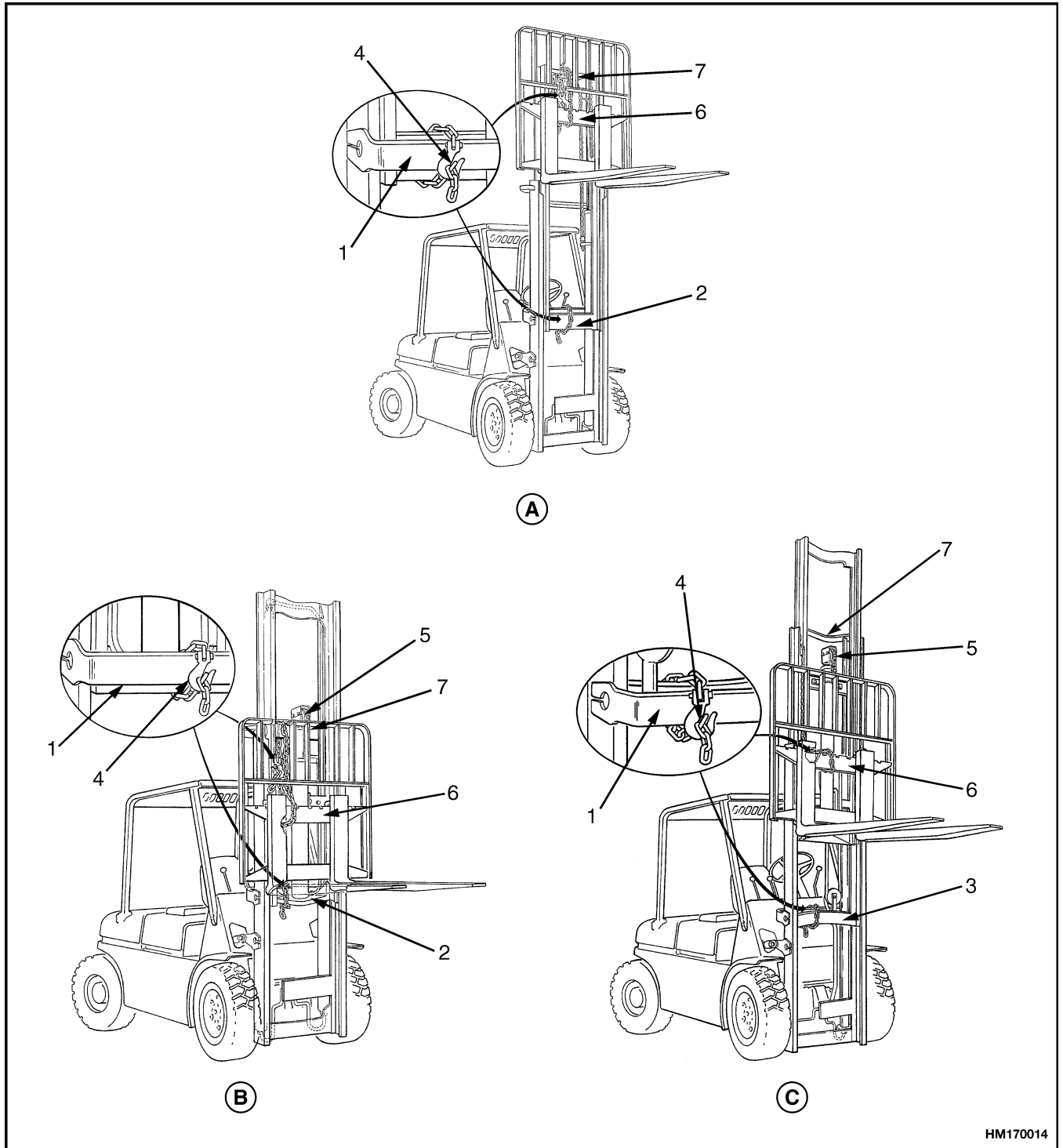
mounts that fit on the pivot pins. Capscrews hold the mast to the pivot pins. See Figure 4.

On ERP030-040TH trucks, the mast pivots on two stubshafts welded to the sides of the outer mast weldment. The mast mounts are part of the transmission housing, which bolt to the truck frame. Each mount uses one bushing. Each mount has a retainer cap that attaches the mast to the mast mount. Each retainer is held in place with four capscrews. See Figure 5.



- |                        |                 |
|------------------------|-----------------|
| 1. RETAINER CAP        | 6. SHIMS        |
| 2. SPACER              | 7. PIN          |
| 3. TILT CYLINDER       | 8. ROD END      |
| 4. OUTER MAST WELDMENT | 9. O-RING       |
| 5. BUSHING             | 10. CAPSCREW    |
|                        | 11. FLAT WASHER |

**Figure 3. Mast Mounts**



HM170014

**A. TWO-STAGE LFL MAST**

**B. TWO-STAGE FFL MAST**

**C. THREE-STAGE FFL MAST**

- 1. OUTER MAST UPRIGHT
- 2. INNER MAST UPRIGHT
- 3. INTERMEDIATE MAST UPRIGHT

- 4. HOOK
- 5. FREE-LIFT CYLINDER
- 6. CROSSMEMBER
- 7. CROSSMEMBER

**Figure 1. Two-Stage LFL, Two-Stage FFL, and Three-Stage FFL Masts**



CLICK HERE TO **DOWNLOAD** THE COMPLETE MANUAL

- Thank you very much for reading the preview of the manual.
- You can download the complete manual from: [www.heydownloads.com](http://www.heydownloads.com) by clicking the link below



- Please note: If there is no response to CLICKING the link, please download this PDF first and then click on it.

CLICK HERE TO **DOWNLOAD** THE COMPLETE MANUAL

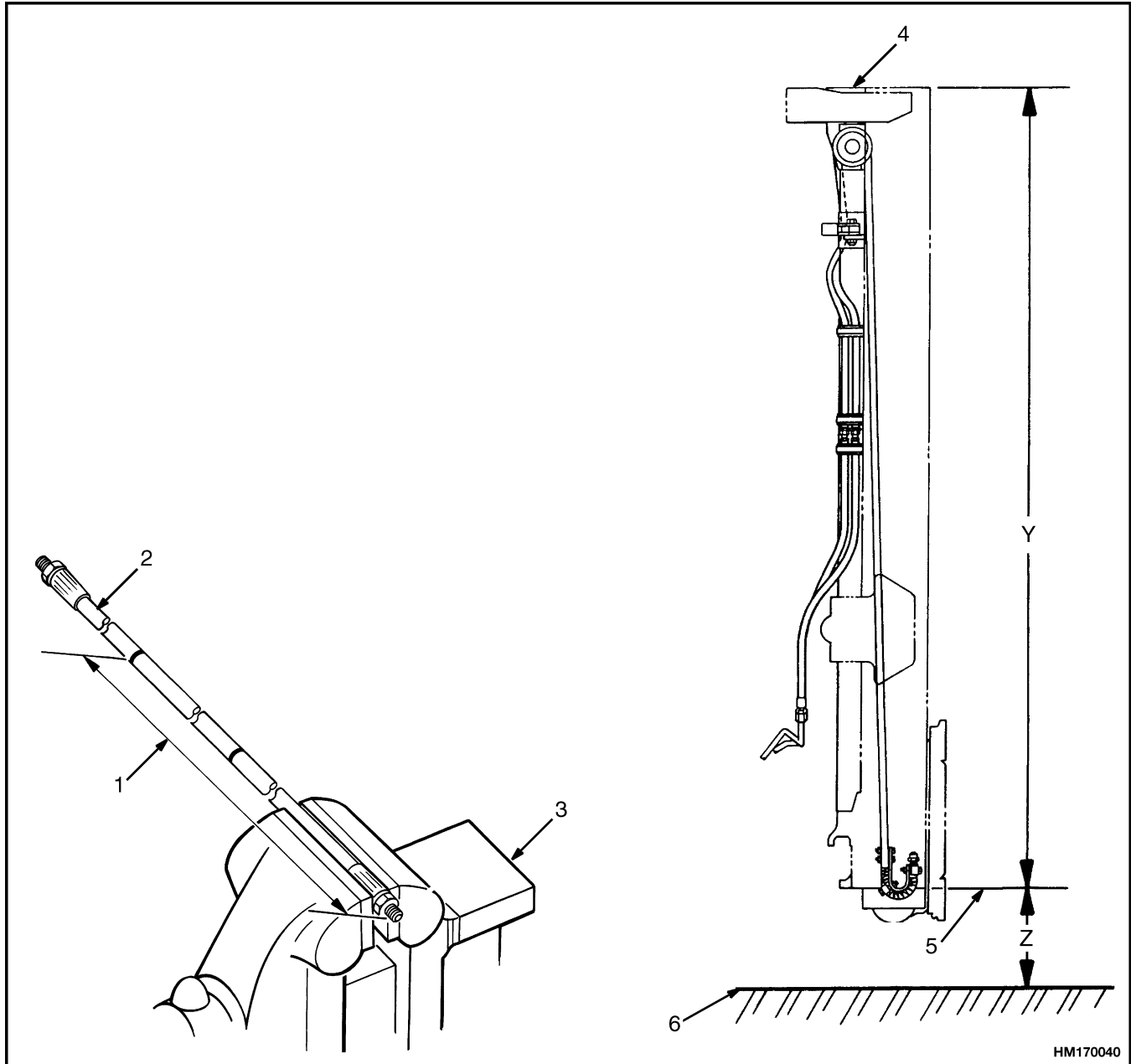
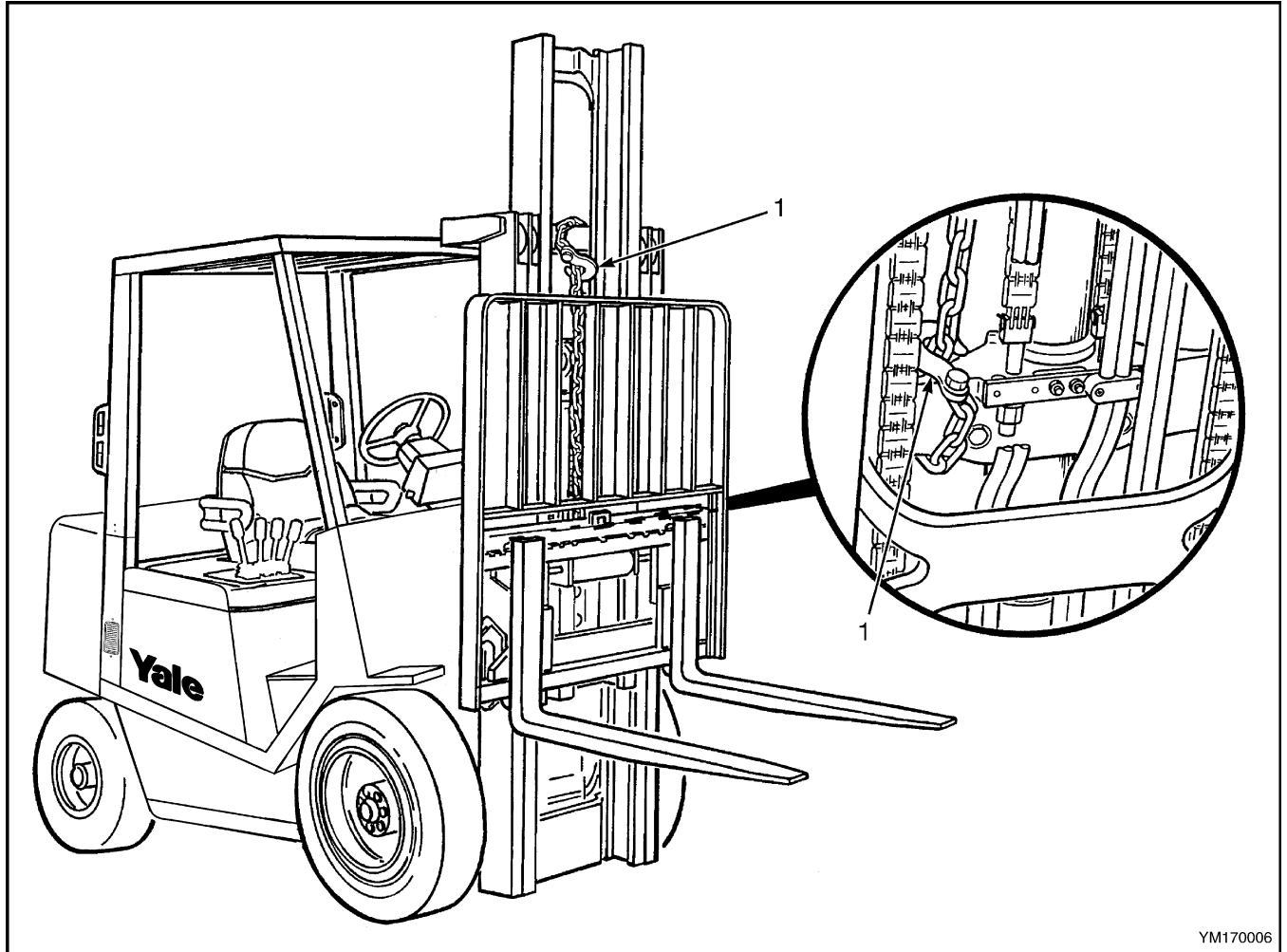


Figure 27. Header Hose Measurement, Two-Stage Limited Free-Lift Mast



YM170006

1. HOOK

2. SHACKLE

**Figure 36. Safety Chain Installation, Two-Stage Full Free-Lift and Three-Stage Full Free-Lift Mast (Sheet 2 of 2)**

**NOTE:** To make the alignment of dimension **E** easier, use a crane with a capacity of at least 908 kg (2002 lb) to raise the carriage high enough to attach a safety chain as shown in Figure 36.

7. Align the mark for dimension **E** at the bottom of the clamp to create the proper hose tension. Tighten the hardware to 8 N•m (71 lbf in). Install the hose guards. Tighten the capscrews that mount the guards to 66 N•m (49 lbf ft).
8. Position the hoses at the hose sheave. See Figure 43 and Figure 44. The hose sheave and stub-shaft must be installed on the hose before they are attached to the mast. Tighten the hardware to 53 N•m (39 lbf ft).
9. Put the clamps over the hoses and attach the clamps to the upper brackets. (DO NOT tighten the hardware.)

**NOTE:** To make the alignment of dimension **G** easier, use a crane to raise the inner channel high enough to install a safety chain as shown in Figure 36.

10. Align mark **G** on hoses **A** and **D** at the bottom edge of clamp to create the proper tension. Align mark **G** on hoses **B** and **C** at the top edge of clamp to create the proper tension. Tighten the hardware to 8 N•m (71 lbf in).
11. Install the clamps.
12. Connect the header hoses to the cowl hoses.
13. Use the rubber clamps and strap clamps to attach the hoses to the main lift cylinders. Make sure the hoses do not stretch or fold while tilting the mast fully forward and backward.
14. With no load on the forks, check the header hose adjustment by operating the mast through the full lift cycle two times. When properly adjusted, the hoses will not be so tight that they compress when they pass over the sheaves nor will they be so loose that they touch the load backrest or any crossmember that is next to a sheave. If the hoses require additional adjustment, see Three-Stage FFL Mast, Adjust Hoses After Install.

### THREE-STAGE FFL MAST, ADJUST HOSES AFTER INSTALL

**NOTE:** The lift chains and carriage height must be correctly adjusted before the header hoses can be adjusted. See the section Lift Chains Adjustment for adjustment procedures.

1. If the tension of the hoses is correct between the carriage and the clamp at the free-lift bracket, go to Step 2. If the tension of the hoses is wrong, loosen the clamps and pull (if the hoses are loose) or push (if the hoses are tight) on the hoses so they move 15 mm (0.6 in.). Tighten the hardware to 8 N•m (71 lbf in). See Figure 36, Figure 42, Figure 43, and Figure 44.
2. If the tension of the hoses is correct between the clamp at the upper bracket and the clamp at the free-lift bracket, go to Step 3. If the tension of the hoses is wrong, loosen the clamps and pull (if the hoses are too loose) or push (if the hoses are too tight) on the hoses so they move 15 mm (0.6 in.), plus the amount the hoses were moved in Step 1. Tighten the hardware to 8 N•m (71 lbf in).
3. With no load on the forks, check the header hose adjustment by operating the mast through the full lift cycle two times. When properly adjusted, the hoses will not be so tight that they compress when they pass over the sheaves nor will they be so loose that they touch the load backrest or any crossmember that is next to a sheave. If necessary, repeat Step 1 and Step 2 until the hoses are properly adjusted.

Table 1. Maintenance Schedule (Continued)

Item No.	Item	8 hr/ 1 day	250 hr/ 6 wk	500 hr/ 3 mo	1000 hr/ 6 mo	2000 hr/ 1 yr	Procedure or Quantity	Specification
9	Engine Oil (Diesel) Mazda XA and HA En- gines	X CIL	C				See NOTE 2  7.4 liter (7.8 qt)	-15 to 40°C (5 to 104°F) SAE 10W-30 -10 to 50°C (14 to 122°F) SAE 15W-40 API CG4/CH4 ACEA E3/E5 MIL-PRF-2104G
6	Engine Oil Filter		C				1 See NOTE 2	See Parts Manual
	Fuel Filter, Diesel	X			C		Clean or Replace See NOTE 3	See Parts Manual
	Water Separator, Diesel (Prefilter)	X CIL			C		Remove Water Clean or Replace	See Parts Manual
12	Brake Fluid	CIL	X				0.2 liter (0.4 pt)	SAE J-1703
23	Hydraulic Oil GP/GLP/GDP040- 060RG/TG/ZG	X	X			C	See NOTE 4 35.0 liter (37.0 qt)	API CC or CC/SE -18°C (0°F) and Above SAE 10W
23	Hydraulic Oil GC/GLC040-065RG/ TG/ZG	X	X			C	See NOTE 4 34.0 liter (36.0 qt)	API CC or CC/SE -18°C (0°F) and Above SAE 10W
4	Cooling System Mazda FE and F2 En- gines	X CIL				C	See NOTE 5 11.0 liter (11.6 qt)	50% Water and 50% Ethylene Glycol Boron-Free Antifreeze
4	Cooling System GM 3.0L	X CIL				C	See NOTE 5 11.0 liter (11.6 qt)	50% Water and 50% Ethylene Glycol Boron-Free Antifreeze
4	Cooling System GM 3.0L EPA Compli- ant Engine	CIL X			C		See NOTE 5 11.0 liter (11.6 qt)	50% Water and 50% Ethylene Glycol Boron-Free Antifreeze
4	Cooling System Mazda XA and HA Diesel	X CIL				C	See NOTE 5  11.0 liter (11.6 qt)	50% Water and 50% Ethylene Glycol Boron-Free Antifreeze
	Cooling System Clean Debris From Ra- diator Core		X					
7	Air Filter	CIL	X				Clean or Replace See NOTE 3 and NOTE 4	See Parts Manual
7	Air Filter Element GM 3.0L EPA Compli- ant Engine					C	Clean or Replace See NOTE 6	See Parts Manual

X=Check C=Change L=Lubricate CIL=Check Indicator Light during operation

### Timing Belt

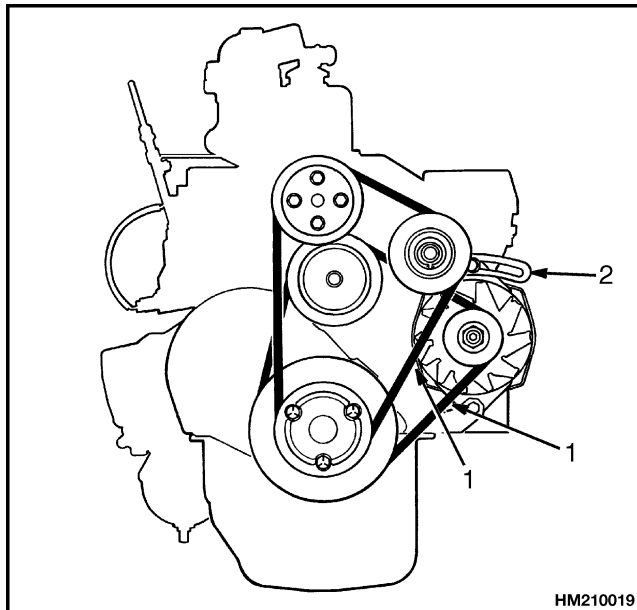
Check timing belt for wear and damage. The cover for the timing belt must be removed for checks and adjustments. See the section **Mazda Engine, FE and F2 600 YRM 496** for more information. Small cracks that run across the belt are acceptable. A belt with cracks that run the length of the belt or a belt with missing pieces is not acceptable.

Check tension by pushing on drive belt to check deflection. When the pressure is 90 N (20 lbf), the correct deflection is approximately 13 mm (0.5 in.). To change the adjustment of the timing belt, do the following:

1. Loosen lock bolt for tensioner and apply spring tension to belt.
2. When the belt tension is correct, tighten lock bolt to 20 to 35 N•m (15 to 26 lbf ft).

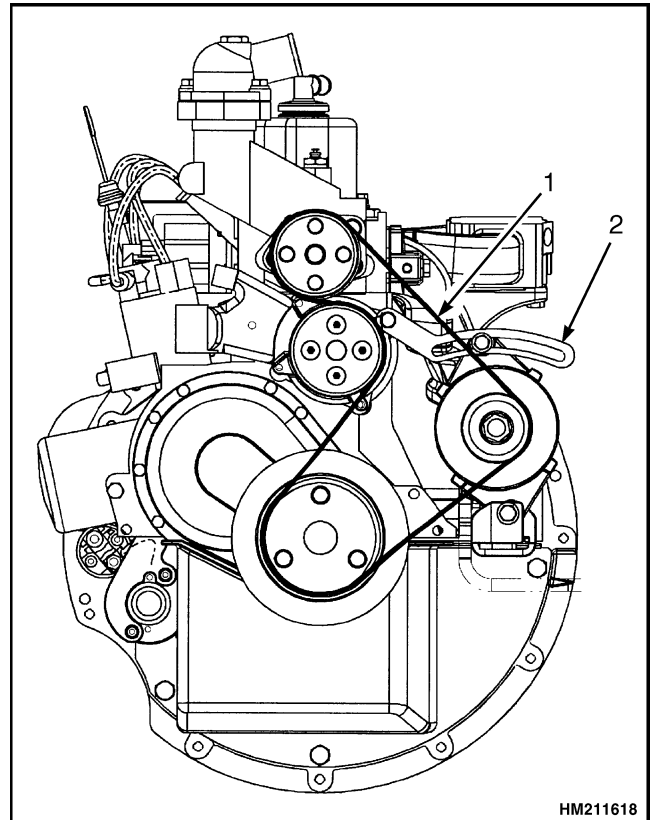
### GM 3.0L

Check drive belts for fan, alternator, and water pump for wear and damage. See Figure 20 and Figure 21.



1. CHECK TENSION HERE
2. ALTERNATOR SUPPORT BRACKET

**Figure 20. Drive Belts Check, GM Engines With V-Belts**



1. CHECK TENSION HERE
2. ALTERNATOR SUPPORT BRACKET

**Figure 21. Drive Belt Check, GM Engines With Serpentine Belt**

For V-shaped drive belts, check tension on fan belt by pushing on drive belt to check deflection. When the pressure is 90 N (20 lbf), the correct deflection is approximately 14 to 16 mm (0.55 to 0.63 in.). Loosen support bracket for idler pulley to adjust tension of V-belt.

For V-shaped drive belts, check tension on alternator belt by pushing on drive belt to check deflection. When the pressure is 90 N (20 lbf), the correct deflection is approximately 10 to 13 mm (0.4 to 0.5 in.). Loosen support bracket for alternator to adjust tension of V-belt.

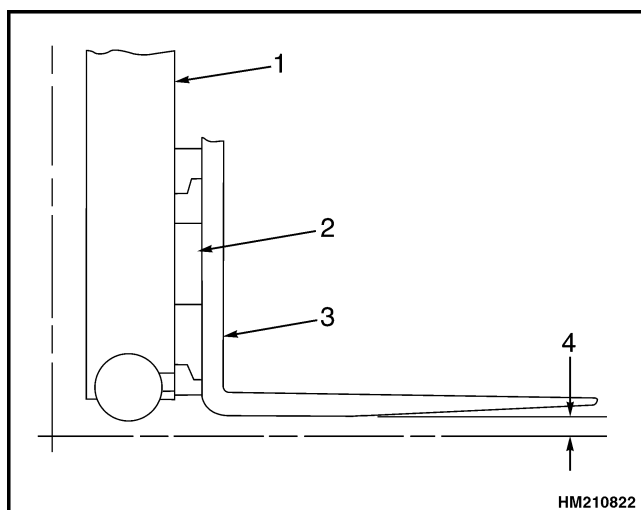
For the serpentine drive belt, check the tension on the fan belt by pushing the drive belt to check deflection. When the pressure is 133 N•m (30 lbf), the correct deflection is approximately 4 to 6 mm (0.16 to 0.24 in.). Loosen the support bracket for the alternator to adjust tension of serpentine belt.

**NOTE:** When the chain adjustments are complete, make sure the threads on the nuts of the chain anchors are completely engaged. Make sure all of the adjustment is not removed from the chain anchors. The chain anchors must be able to move on their mounting.

1. When adjusting lift chains on forklift trucks equipped with either pin or hook-type forks installed, go to Step 2. If forklift truck is normally equipped with a hook-type carriage and has an attachment without forks, go to Step 3. If forklift truck is normally equipped with a pin-type carriage and has an attachment without forks, go to Step 4.

**NOTE:** Prior to performing adjustment procedures, make sure the forklift truck is parked on a level surface and the mast is in the vertical position.

2. Adjust chain anchors which support the carriage until the bottom of the fork heel is  $6 \pm 3$  mm ( $0.24 \pm 0.12$  in.) above floor level. See Figure 43.



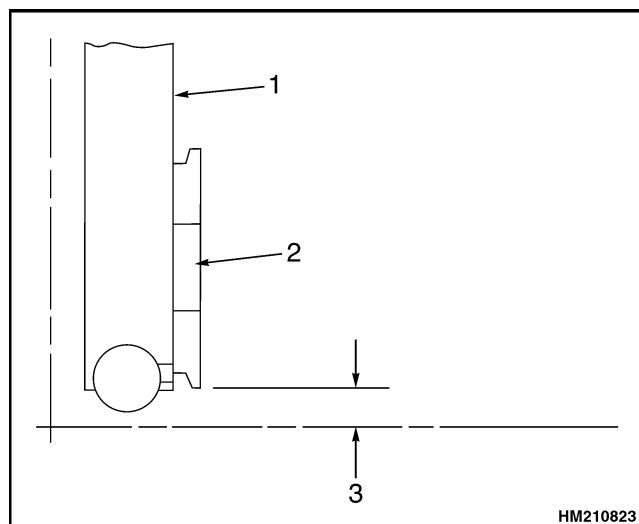
1. MAST
2. CARRIAGE
3. FORK
4. HEEL OF FORK IS  $6 \pm 3$  mm ( $0.25 \pm 0.12$  in.) ABOVE FLOOR LEVEL.

**Figure 43. Lift Chain Adjustment, Hook- or Pin-Type Forks**

3. Adjust chain anchors which support the carriage until the bottom of the lower carriage bar is above the floor level as shown in Table 2. See Figure 44.

**Table 2. Hook-Type Carriage Chain Adjustment**

Class II and III	$82.5 \pm 3$ mm ( $3.25 \pm 0.12$ in.)
Class IV	$133.5 \pm 3$ mm ( $5.26 \pm 0.12$ in.)



1. MAST
2. CARRIAGE
3. DISTANCE FROM FLOOR TO LOWER CARRIAGE BAR

**Figure 44. Lift Chain Adjustment, Hook-Type Carriage**

4. Adjust chain anchors which support the carriage until the center line of the fork pin is above the floor level as shown in Table 3. See Figure 45.

**Table 3. Pin-Type Carriage Chain Adjustment**

GP070-090LJ	$545 \pm 3$ mm ( $21.5 \pm 0.12$ in.)
GP100-120MJ	$708 \pm 3$ mm ( $27.87 \pm 0.12$ in.)
GP135-155CA	$907 \pm 3$ mm ( $35.71 \pm 0.12$ in.)

## Lift Truck Weights

Unit	kg	lb
GC040RG	2,813	6,202
GC050RG/TG/ZG	3,173	6,995
GC060TG/ZG	3,574	7,880
GC065TG/ZG	3,721	8,203
GP20RF (GP040RG)	3,720	8,201
GP25TF (GP050ZG)	4,070	8,973
GP30TF (GP060TG)	4,555	10,041

**NOTE:** All pneumatic tire units are equipped with gasoline engine, standard carriage, forks, two-stage limited free-lift mast, and 91 kg (200 lb) operator.

**NOTE:** All cushioned tire units are equipped with powershift transmission, standard tires, and overhead guard (without the front end).

## Tire Pressure

Bias Ply Tires		
GP20-30RF/TF (GP040-060RG/TG/ZG)		
Tire Size	kPa	psi
6.00 × 9, 10 ply	860	125
6.50 × 10, 10 ply	795	115
7.00 × 12, 12 ply	860	125
28 × 9 - 15, 12 ply	825	120

Radial Tires			
GP20-30RF/TF (GP040-060RG/TG/ZG)			
Tire Size	kPa	psi	Warning
6.00 R9	1000	145	<div style="border: 1px solid black; padding: 5px;"> <p style="text-align: center;"><b>! WARNING</b></p> <p><b>SPECIAL RADIAL TIRES AND WHEELS</b></p> <p>Use <b>ONLY</b> the Michelin® tires specified on the Nameplate, inflated to the specified pressure. Use only lock ring style wheels with radial tires. Do not use two piece (bolt together) wheels with radial tires.</p> <p>Other types or brands of radial tires, or mixing with bias-ply tires can cause improper handling or increase risk of tipover. Use of other wheels can cause wheel failure.</p> <p>Improper handling, tipover, or wheel failure can result in <b>SERIOUS INJURY OR DEATH!</b></p> <p>Consult your dealer for this lift truck for the correct tire and wheel specification and lift capacity rating before installing bias-ply tires. All tires and wheels <b>MUST</b> be the same type.</p> </div>
6.50 R10	1000	145	
7.00 R12	1000	145	
225/75 R15	1000	145	

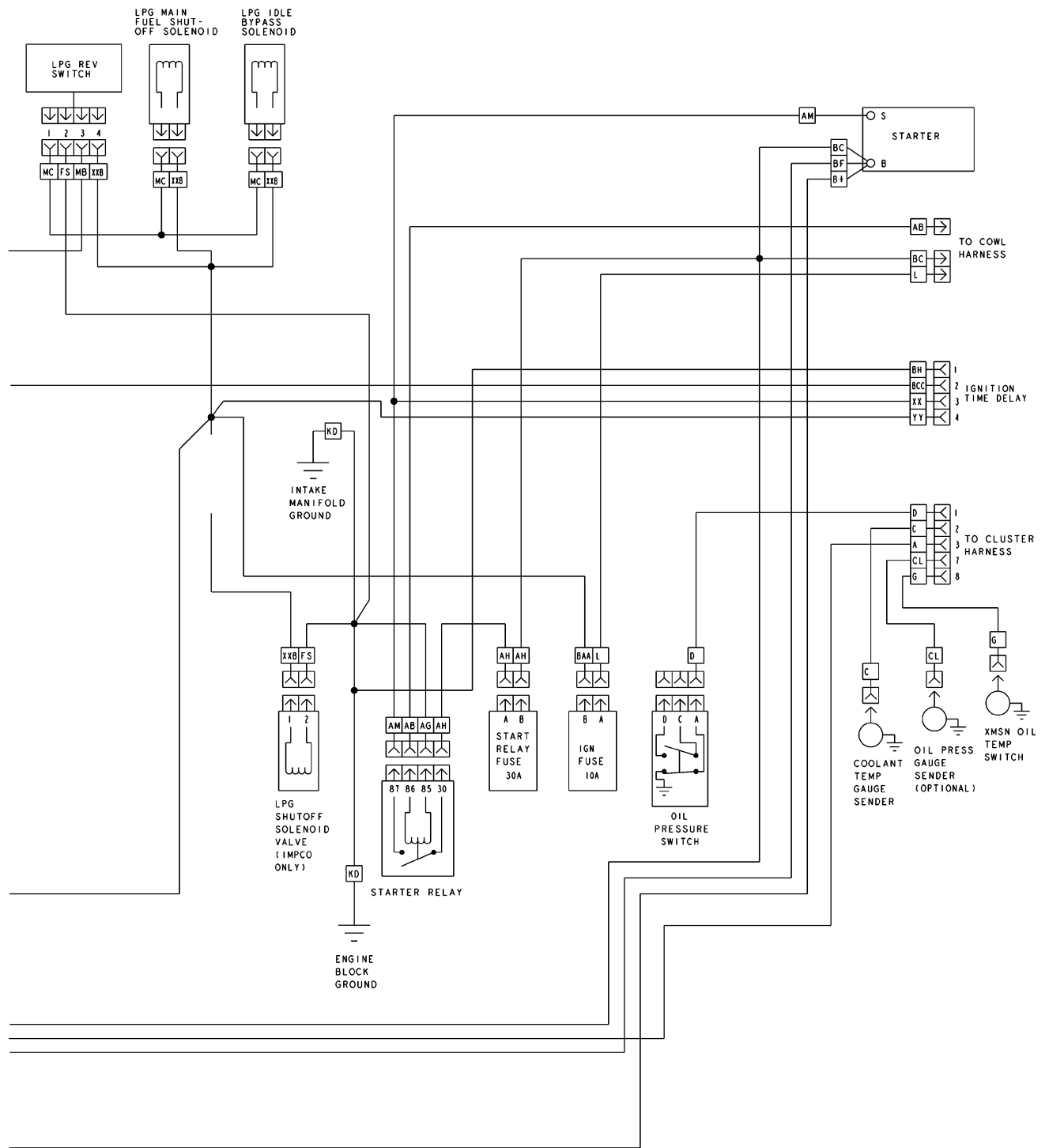
BM210009

**DIESEL ENGINES (EUROPEAN MODELS)**

Mazda XA Engine								
Two-Stage Limited Free-Lift								
Unit	Lifting*				Lowering*			
	No Load		Rated Load		No Load		Rated Load	
	m/sec	ft/min	m/sec	ft/min	m/sec	ft/min	m/sec	ft/min
<b>GDP20RF</b>	0.61	119	0.55	108	0.42	83	0.50	99
<b>GDP25RF</b>	0.61	119	0.54	105	0.42	83	0.50	99
<b>GDP30RF</b>	0.53	104	0.46	91	0.42	83	0.50	99
<b>* Hydraulic oil temperature 65°C (149°F). Plus or minus 10% acceptable for lifting and lowering.</b>								

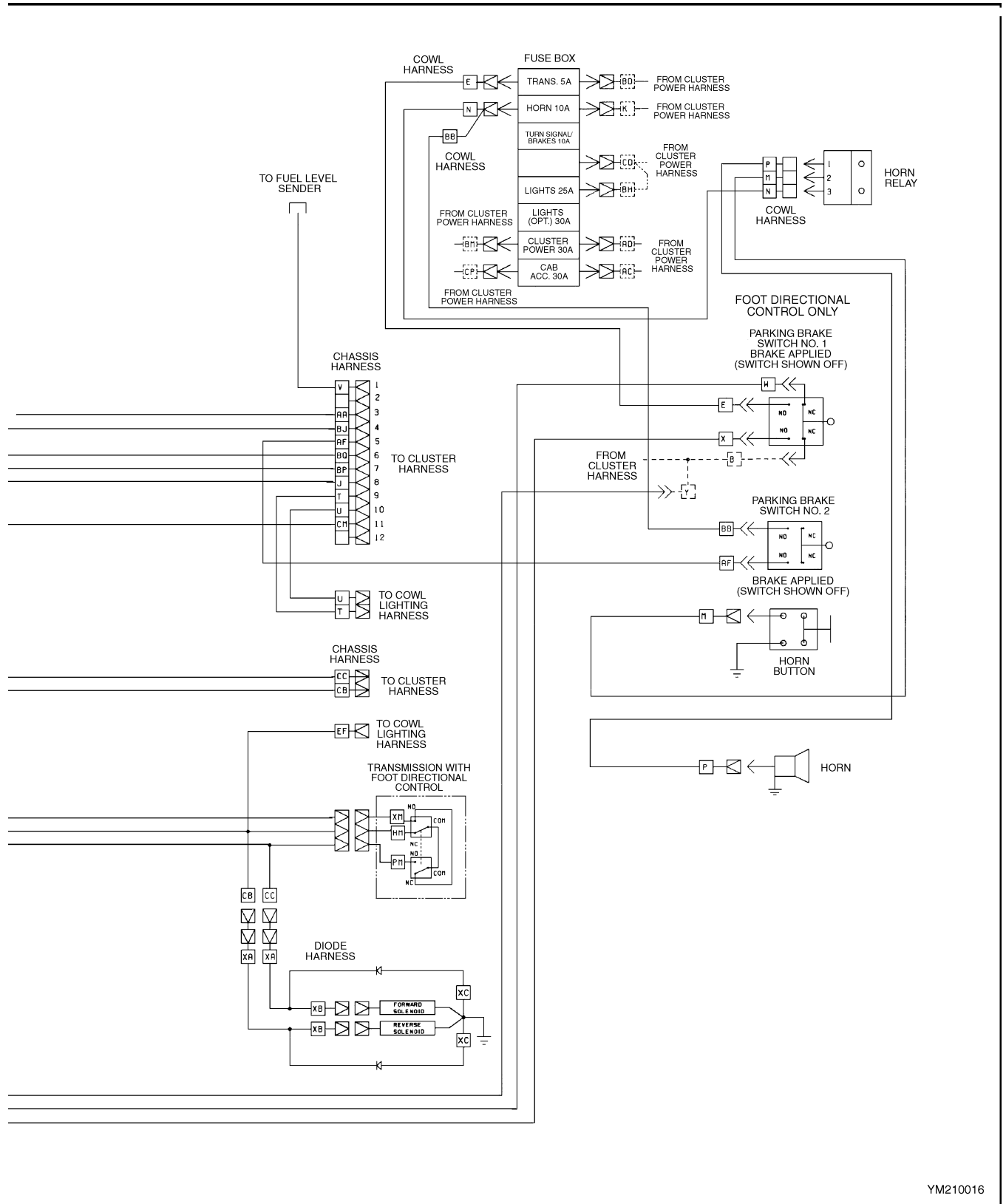
Mazda XA Engine								
Two-Stage Full Free-Lift								
Unit	Lifting*				Lowering*			
	No Load		Rated Load		No Load		Rated Load	
	m/sec	ft/min	m/sec	ft/min	m/sec	ft/min	m/sec	ft/min
<b>GDP20RF</b>	0.55	107	0.50	98	0.42	83	0.50	99
<b>GDP25RF</b>	0.55	107	0.49	96	0.42	83	0.50	99
<b>GDP30RF</b>	0.52	102	0.46	90	0.42	83	0.50	99
<b>* Hydraulic oil temperature 65°C (149°F). Plus or minus 10% acceptable for lifting and lowering.</b>								

Mazda XA Engine								
Three-Stage Full Free-Lift								
Unit	Lifting*				Lowering*			
	No Load		Rated Load		No Load		Rated Load	
	m/sec	ft/min	m/sec	ft/min	m/sec	ft/min	m/sec	ft/min
<b>GDP20RF</b>	0.58	113	0.53	103	0.42	83	0.50	99
<b>GDP25RF</b>	0.58	113	0.51	100	0.42	83	0.50	99
<b>GDP30RF</b>	0.52	101	0.45	89	0.42	83	0.50	99
<b>* Hydraulic oil temperature 65°C (149°F). Plus or minus 10% acceptable for lifting and lowering.</b>								



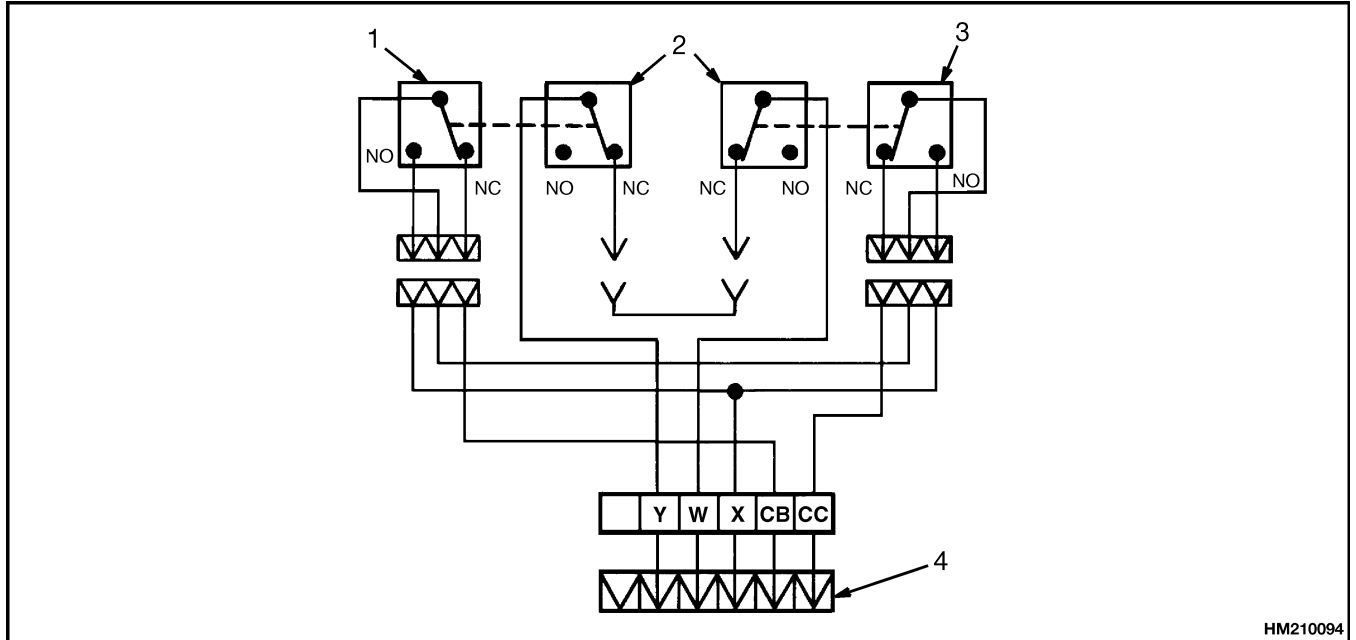
HS210005

Figure 5. GM 3.0L LPG Engine Without MSTs Wiring Schematic (Late Models)



YM210016

Figure 17. GM 3.0L Engine Chassis Wiring Schematic (Early Models)



HM210094

**COLOR CODES:** Y = WHITE, W = GREEN, X = RED, CB = LIGHT GREEN (REV SOLENOID), CC = ORANGE/BLACK (FWD SOLENOID)

- 1. REVERSE CONTROL SWITCH
- 2. NEUTRAL START SWITCH
- 3. FORWARD CONTROL SWITCH
- 4. CONNECTOR-TO-COWL WIRING HARNESS

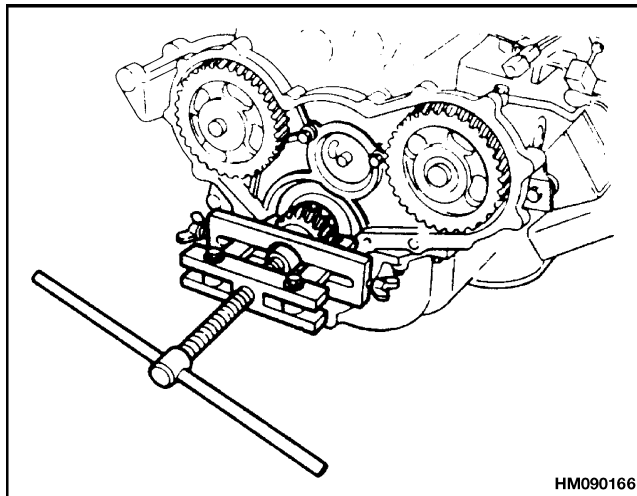
**Figure 27. Transmission Control Lever Schematic**

5. Adjust the valves. See the Checks and Adjustments section for the valve adjustment procedures.
6. Use a new gasket and install the valve cover. Tighten the capscrews to 30 to 45 N•m (22 to 33 lbf ft).

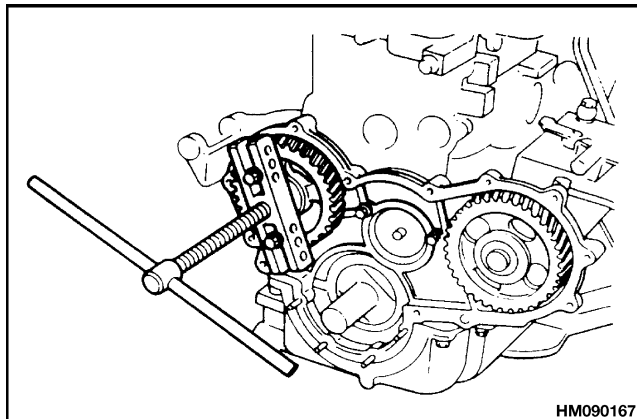
## Timing Gears Repair

### REMOVE

1. Remove the timing gear cover.
2. Remove the capscrews for the thrust plate and idler gear and hub. Remove the parts from the engine.
3. Use a puller and remove the crankshaft timing gear. See Figure 16.
4. Remove the capscrew, washer, and lock plate for the camshaft gear. Remove the friction gear. See Figure 17. Use a puller and remove the camshaft timing gear.

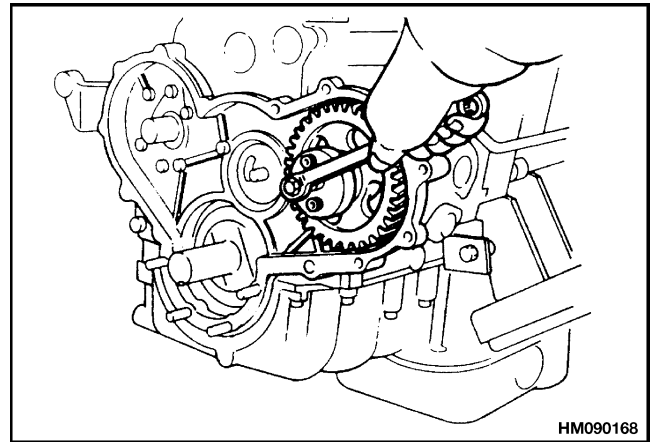


**Figure 16. Crankshaft Gear Removal**



**Figure 17. Camshaft Timing Gear Removal**

5. Remove the nut, washer, and friction gear for the fuel injection pump. See Figure 18. Use a removal tool to remove the timing gear. See the section Special Tools. Remove the mounting nuts for the fuel injection pump, then remove the fuel injection pump.
6. If necessary, the timing gear case can be removed from the engine block.



**Figure 18. Injection Pump Timing Gear Removal**

### CLEAN AND INSPECT

#### WARNING

Cleaning solvents can be flammable and toxic and can cause skin irritation. When using cleaning solvents, always follow the solvent manufacturer's recommended safety procedures.

Clean all of the parts in solvent. Make sure that all oil passages are clean. Check the gears for damaged teeth, burned surfaces, or worn surfaces. Measure the inner diameter of the idler gear and the outer diameter of the idler hub. The standard clearance between the two parts is 0.034 to 0.084 mm (0.0013 to 0.0033 in.). Maximum clearance is 0.15 mm (0.0059 in.). If the clearance exceeds the limits, install a new bushing in the idler gear and use a new hub.

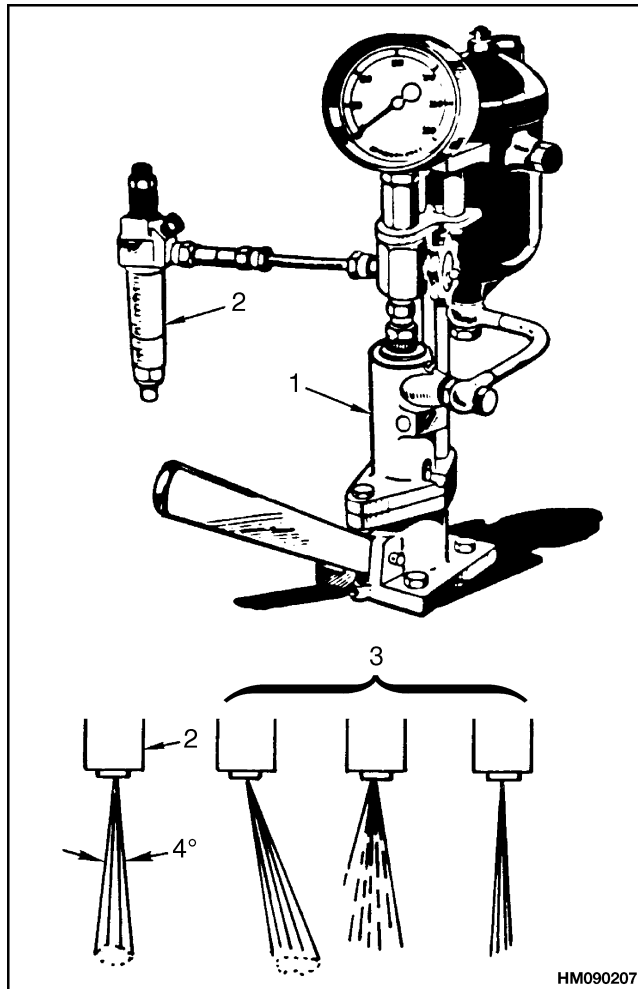


Figure 65. Fuel Injectors Check

**Legend for Figure 65**

1. INJECTOR TESTER
2. FUEL INJECTOR (CORRECT PATTERN)
3. PATTERN NOT CORRECT

**Install**

1. Install the complete fuel injectors in the cylinder head.
2. Install and connect the fuel lines to the injectors. Install the line clamps if they were removed.
3. Remove the air from the fuel system. See Fuel System Air Removal.
4. When the engine can be operated, check for fuel leaks.

## Flywheel and Ring Gear Repair

### FLYWHEEL, REMOVE

**NOTE:** The procedures to remove and install the flywheel and replace the ring gear that follow, apply only to model GDP2.00-3.00RF/TF (GDP040-060RF/TF).

1. Remove the capscrews for the flywheel, then remove the flywheel and the drive plate.
2. If necessary, remove the flywheel housing.

### RING GEAR, REPLACE

**⚠ WARNING**

**Wear eye protection for this operation to prevent eye injury from metal chips. You will be using a hammer and chisel to break the ring gear.**

Before the ring gear is removed, check the position of the chamfer on the teeth.

1. Use a hammer and chisel to break the ring gear. Make sure that you do not damage the flywheel. See Figure 66.



**Legend for Figure 18**

- |                            |                     |                                  |
|----------------------------|---------------------|----------------------------------|
| 1. FUEL INJECTOR           | 5. FUEL RETURN LINE | 10. CHECK PORT FOR FUEL PRESSURE |
| 2. FUEL PRESSURE REGULATOR | 6. FUEL FILTER      | 11. BAFFLE                       |
| 3. THROTTLE BODY           | 7. FUEL PUMP        |                                  |
| 4. FUEL PRESSURE LINE      | 8. SCREEN           |                                  |
|                            | 9. FUEL TANK        |                                  |

A small turbine pump connected to an electric motor is installed in the fuel tank below the liquid level. See Figure 19. The fuel pressure regulator on the throttle body keeps the fuel pressure at a constant 72 kPa (10.5 psi). Fuel that is not used by the throttle body is returned to the fuel tank. A screen is connected to the fuel pump to prevent large particles from entering fuel system. Baffles are installed in fuel tank to make sure that fuel is always available to the fuel pump during normal operation of the lift truck.

A fuel filter must be used in series with the fuel pump to prevent any dirt from entering the fuel injectors in the throttle body. The orifices in the fuel injectors are very small in diameter, and a particle of dirt can stop the operation. A liquid level sender for the fuel gauge is often fastened to the support for the fuel pump.

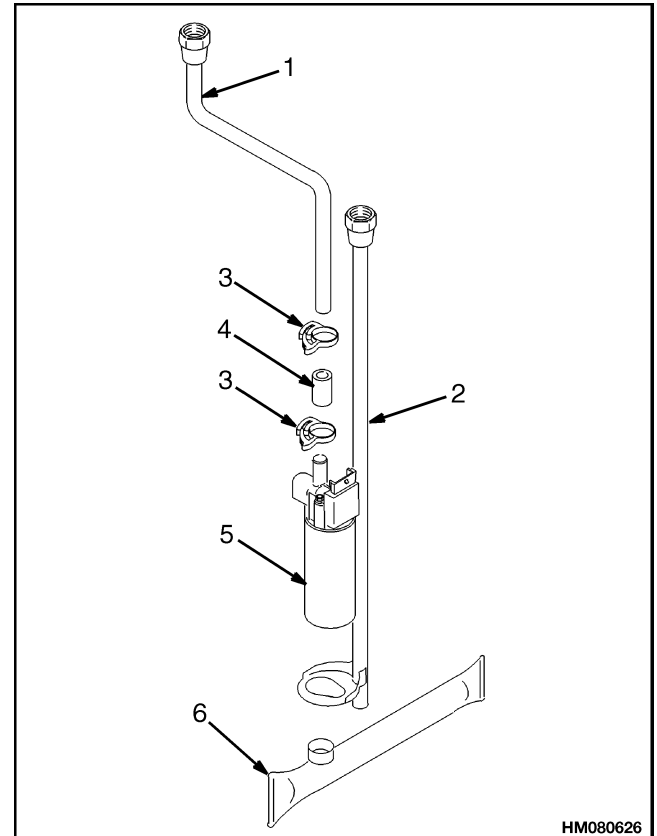
A fuse and fuel pump relay switch for the fuel pump are mounted in the engine compartment. See Figure 2 and Figure 3. When the key switch is first turned to **ON**, the ECM energizes the fuel pump relay for 2 seconds. This action quickly raises the fuel pressure to the fuel injectors. If the engine is not started within 2 seconds, the ECM de-energizes the fuel pump relay; and the fuel pump turns off. When the engine is cranked by the starter, the ECM energizes the fuel pump relay again so that the fuel pump operates.

This ECM control also prevents the fuel pump from operating if the ignition switch is turned to **ON** and the engine is not running.

When the engine is running or being cranked by the starter, the ECM receives reference pulses from the EST distributor or the DIS module. The ECM then energizes the fuel injectors.

The fuel pump can also be energized by the oil pressure switch. When the engine is being cranked by the starter and engine oil pressure is approximately 28 kPa (4 psi), the oil pressure switch closes a circuit to operate the fuel pump. If the fuel pump relay is not operating correctly, a long cranking time for a cold engine

will be the result. The oil pressure switch will energize the fuel pump when the engine oil pressure increases to approximately 28 kPa (4 psi).



- |   |                        |
|---|------------------------|
| 1. OUTLET FUEL LINE                       | 4. FLEXIBLE COUPLING   |
| 2. RETURN FUEL LINE AND FUEL PUMP SUPPORT | 5. FUEL PUMP AND MOTOR |
| 3. CLAMP (2)                              | 6. SCREEN              |

**Figure 19. Fuel Pump**

Table 4. On-Board Diagnostic System Checks

Step	Action	Value	Yes	No
1	Turn ignition <b>ON</b> , leaving engine OFF Is Malfunction Indicator Lamp (MIL) illuminated steady? or is MIL flashing DTC 12?		Go to Step 2. Go to Step 7.	Go to A-1 No Malfunction Indicator Lamp.
2	Install SCAN Tool Does SCAN Tool display DTC 12?		Go to Step 3.	Go to A-2 No Scan Data, No DTC-12, Malfunction Indicator Lamp ON.
3	Does SCAN Tool display ECM data?		Go to Step 4.	Go to A-2 No Scan Data, No DTC-12, Malfunction Indicator Lamp ON.
4	Does engine start?		Go to Step 5.	Go to A-3 Engine Cranks but Does Not Run.
5	Were any other DTCs displayed?		Go to applicable DTC chart. Start with lowest numbered DTC.	Go to Step 6.
6	Compare SCAN Tool data with typical values shown in Rinda SCAN Tool Information Are values normal or within range?		Go to Troubleshooting, Poor Operation.	Troubleshoot the components, circuit, or system the SCAN Tool indicates is not within normal values.
7	Check for grounded diagnostic test circuit <b>438</b> . Was problem found?		Go to Step 1.	Go to Step 8.
8	Replace ECM. Is action complete?		Verify repair.	

## Troubleshooting Charts

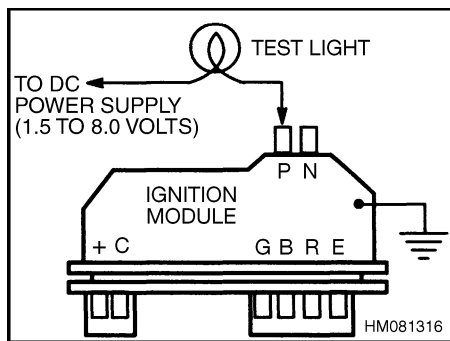
### GENERAL



#### WARNING

This troubleshooting requires the operation of the engine for some tests. Make sure tests are done carefully to prevent injury:

- Put the lift truck on a level surface. Lower the carriage and forks and apply the parking brake. Make sure the lift truck cannot move and cause an injury during the tests. Use blocks, as necessary, to prevent movement of the lift truck.
- The fuel system and the engine must operate correctly. Any problems or leaks in the fuel system and the engine must be repaired before doing troubleshooting.
- The fan and the drive belts can remove fingers or cause other injuries. Be careful that your hands and tools do not touch the moving fan or the drive belts.



**Figure 15. Ignition Module**

6. Use the test light to check for a short circuit in the EST module or in circuit from the ignition coil to the EST module. Check for approximately 12 volts between the **TACH CONN.** and ground. If the voltage is low (approximately 1 to 6 volts), there can be a fault in the ignition coil. This condition can cause a failure in the ignition coil from too

much heat. If there is an open circuit in the primary winding of the ignition coil, a low voltage can leak through the EST module from the **B+** to the **TACH CONN.** terminal.

9. EST module normally goes ON when 1.5 to 8 volts are applied to terminal **P**. When EST module is ON, voltage between **TACH CONN.** and ground will normally decrease to 7 to 9 volts. This test checks if the sensing coil or EST module has a fault. When 1.5 to 8 volts are momentarily applied to terminal **P**, this voltage acts as a trigger voltage that replaces voltage from sensing coil. The procedure shows a test light, but any low-voltage, low-current source can be used as a trigger voltage.
10. When momentary trigger voltage is removed, a spark is normally generated through the ignition coil. If no spark occurs, replace ignition coil. If a spark occurs, check sensing coil and rotating timer core.

**Table 14. Ignition System Troubleshooting**

Step	Action	Value	Yes	No
1	Did you perform the On-Board Diagnostic (OBD) System Check?		Go to Step 2.	Go to On-Board Diagnostic (OBD) System Check.
2	<ol style="list-style-type: none"> <li>1. Disconnect tachometer.</li> <li>2. Turn ignition switch to <b>ON</b>.</li> <li>3. Use the starter to rotate the engine; do not start the engine.</li> <li>4. Using a spark tester, check for a spark at the No. 1 spark plug wire. If there is no spark on the No. 1 wire, check another wire.</li> </ol> <p>Is spark present?</p>		Go to Step 13.	Go to Step 3.
3	Disconnect the four-terminal ignition module connector located on the distributor and check for spark. See Figure 15. Is there spark?		Go to Step 14.	Go to Step 4.
4	<ol style="list-style-type: none"> <li>1. Turn ignition switch to <b>ON</b>, leaving the engine <b>OFF</b>.</li> <li>2. Use the starter to rotate the engine; do not start the engine.</li> <li>3. Using a spark tester, check for a spark at the coil wire.</li> </ol> <p>Is spark present?</p>		Go to Step 15.	Go to Step 5.

Table 25. DTC 42 Electronic Spark Timing (EST) - Grounded EST Circuit, Open or Grounded Bypass Circuit

Step	Action	Value	Yes	No
1	Was the On-Board Diagnostic (OBD) system check performed?		Go to Step 2.	Go to On-Board Diagnostic (OBD) System Check.
2	<ol style="list-style-type: none"> <li>1. Clear codes from the ECM. Go to Diagnostic Aids.</li> <li>2. Start engine and run at idle speed for at least 1 minute and check for Code 42.</li> </ol> <p>Does Code 42 appear?</p>		Go to Step 3.	Code 42 is not constant or regular. If no other codes are stored, go to Troubleshooting, Poor Operation.
3	Connect a test light between battery voltage and circuit <b>437</b> at the ECM connector. Is the light off?		Go to Step 4.	Go to Step 7.
4	<ol style="list-style-type: none"> <li>1. Connect an ohmmeter between ground and circuit <b>436</b> at the ECM cable connector.</li> <li>2. Connect a test light between battery voltage and circuit <b>437</b> at the ECM cable connector.</li> <li>3. When the test light probe touches circuit <b>437</b>, the resistance will correctly make a switch from less than 1,000 ohms to greater than 2,000 ohms.</li> </ol> <p>Does resistance change?</p>		Go to Step 6.	Go to Step 5.
5	With the ohmmeter still connected between ground and circuit <b>436</b> at the ECM connector, disconnect the four-way connector at the ignition module. Does resistance go high (open circuit)?		Go to Step 8.	Go to Step 9.
6	<ol style="list-style-type: none"> <li>1. Connect the ECM connector to the ECM.</li> <li>2. Start the engine and run at idle for at least 1 minute and check for Code 42.</li> </ol> <p>Is Code 42 present?</p>		Go to Step 10.	Code 42 is not constant or regular. If no other codes are stored, go to Troubleshooting, Poor Operation.
7	Disconnect the four-way connector at the ignition module. Is the light off?		Go to Step 11.	Go to Step 12.
8	Locate and repair open in circuit <b>437</b> or replace faulty ignition module if open in circuit <b>437</b> is not found. Is action complete?		Verify repair.	

## Install

1. Use a new gasket and install TBI on manifold. Tighten fasteners for TBI to 25 N•m (18 lbf ft).
2. Use new O-rings and washers on fuel lines. Connect fuel pressure and fuel return lines. Tighten fuel line nuts to 27 N•m (20 lbf ft).
3. Connect vacuum hoses.
4. Connect throttle cable at throttle cam. Check adjustment of throttle cables as described in Governor System 3.0L Engine Repair and Governor System 4.3L Engine Repair.
5. Install wiring harness grommet for fuel injector. Connect wires to IAC valve, TPS, and fuel injector.
6. Connect negative cable at battery.
7. Turn key switch **ON** (do not start the engine) and check for fuel leaks.
8. Use a new gasket and connect air filter to TBI.
9. Set position of pintle valve of IAC as follows:
  - a. Depress throttle pedal a small amount.
  - b. Start and run engine for 3 seconds.
  - c. Turn key switch **OFF** for 10 seconds.
  - d. Start engine and check for correct idle operation.

## FUEL METER BODY

### Remove

1. Disconnect negative cable at battery.
2. Disconnect and remove parts that connect air filter to TBI.

3. Disconnect electrical connector at fuel injector. Remove grommet and wires from body. See Figure 39 and Figure 40.



### WARNING

To reduce the risk of fire and personal injury, relieve the fuel system pressure before servicing fuel system components.

After relieving system pressure, a small amount of fuel may be released when servicing fuel lines or connections. To reduce the chance of personal injury, cover fuel line fittings with a shop towel before disconnecting to catch any fuel that may leak out. Place towel in an approved container when disconnect is completed.

4. Disconnect fuel lines at fuel meter body. Hold fittings in fuel meter body to keep them from turning when fuel lines are disconnected.
5. For 4.3L engine, remove fuel line fitting from inlet port in fuel meter body.
6. Remove screws that hold fuel meter body to throttle body.
  - a. For 3.0L engine, remove fasteners that hold TBI to manifold.
  - b. For 4.3L engine, remove fuel meter body and gasket.



### WARNING

Cleaning solvents can be flammable and toxic and can cause skin irritation. When using cleaning solvents, always follow the recommendations of the manufacturer.

7. Clean gasket surfaces on fuel meter body and throttle body with cleaning solvent.

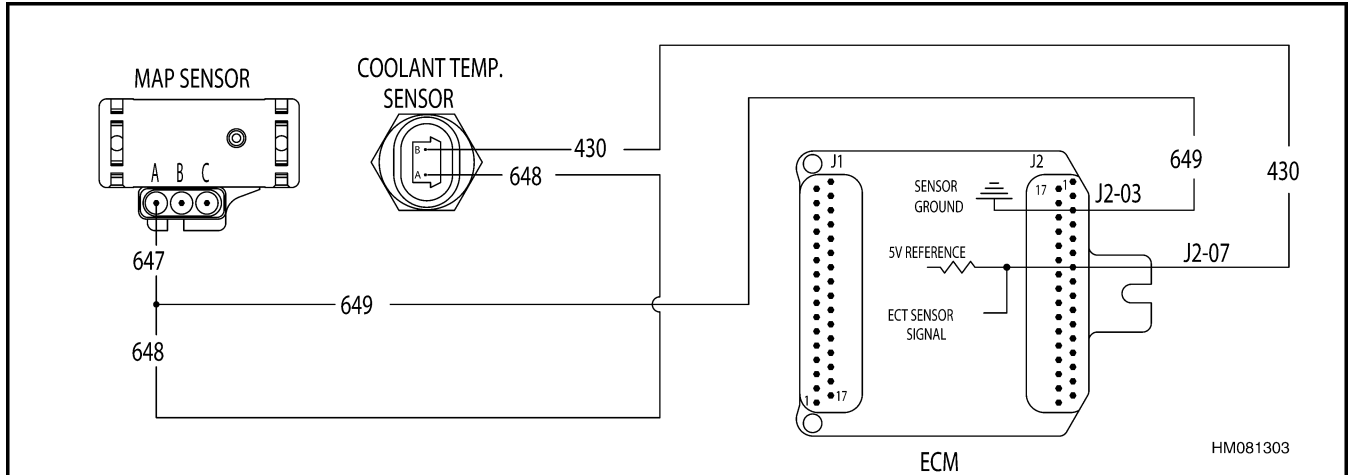


Figure 70. Wiring Connections (Sheet 1 of 2)

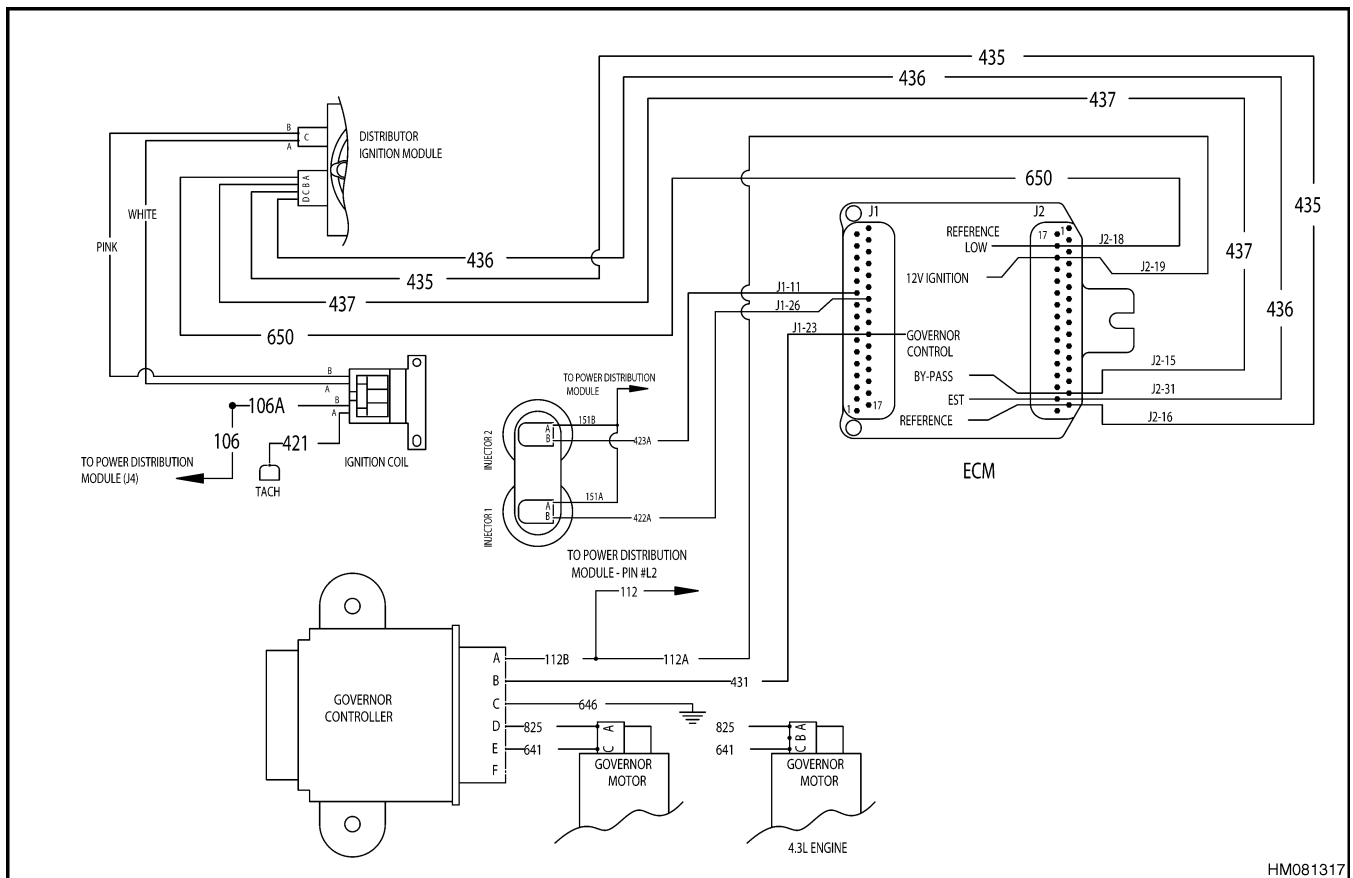


Figure 70. Wiring Connections (Sheet 2 of 2)



**Legend for Figure 23**

- |  |  |
|--|--|
| <ol style="list-style-type: none"> <li>1. MIXER</li> <li>2. BOLTS, THROTTLE BODY TO ADAPTER</li> <li>3. THROTTLE CABLE BRACKET</li> <li>4. THROTTLE CABLE CONNECTION</li> <li>5. FOOT PEDAL POSITION (FPP) SENSOR</li> <li>6. SCREWS</li> <li>7. LOW PRESSURE REGULATOR (LPR) MOUNTING BRACKET</li> <li>8. BOLTS, LPR MOUNTING BOLTS</li> <li>9. VACUUM FITTING</li> <li>10. MANIFOLD GASKET</li> <li>11. THROTTLE BODY TO MANIFOLD ADAPTER</li> <li>12. SCREWS</li> </ol> | <ol style="list-style-type: none"> <li>13. TEMPERATURE MANIFOLD ABSOLUTE PRESSURE (TMAP) SENSOR</li> <li>14. BOLTS, ADAPTER TO MANIFOLD</li> <li>15. O-RING</li> <li>16. BOLTS, THROTTLE BODY TO ADAPTER</li> <li>17. THROTTLE BODY</li> <li>18. FUEL TRIM VALVE (FTV)</li> <li>19. BOLTS</li> <li>20. THROTTLE POSITION SENSOR (TPS)</li> <li>21. GOVERNOR MOTOR</li> <li>22. SCREWS, THROTTLE BODY TO MIXER</li> <li>23. MIXER INLET FITTING</li> <li>24. PIN</li> </ol> |
|--|--|
- 
9. Connect the fuel supply line to the mixer and secure clamp.
  10. Connect the FTV electrical connector.
  11. Connect the governor electrical connector.
  12. Connect the FPP and TPS electrical connectors.
  13. Connect the throttle cable.
  14. Connect the air inlet duct.
  15. Connect the negative battery cable.
  16. Start the vehicle and check the propane fuel system for leaks at each serviced fitting. Refer to Propane Fuel System Leak Test.
  17. Connect the laptop computer and check for DTC codes and no MIL light. See the section **Electronic Control Module (ECM) Diagnostic Troubleshooting, GM 3.0L and 4.3L EPA Compliant Engines 2200 YRM 1090.**

**MIXER REPLACEMENT****Remove**

See Figure 22 for the 3.0L, Figure 23 for the 4.3L, for the following steps:

1. Disconnect the negative battery cable.
2. Remove the air intake duct.
3. Remove the throttle body assembly. Refer to Throttle Body Replacement, Remove.

**NOTE:** Cover throttle body adapter opening to prevent debris from entering engine until assembly.

4. Remove the four screws to the throttle body assembly to mixer.
5. Remove and discard the mixer to throttle body assembly O-ring.

**Install**

See Figure 22 for the 3.0L, Figure 23 for the 4.3L, for the following steps:

**NOTE:** Lightly lubricate the O-ring of the mixer to throttle body O-ring before installing.

1. Install mixer to throttle body O-ring onto the throttle body.
2. Install the mixer to the throttle body assembly and secure with the four screws and torque to 9 N•m (80 lbf in).
3. Install throttle body. Refer to Throttle Body Replacement, Install.
4. Connect the negative battery cable.

**COOLANT HOSE REPLACEMENT****Remove**

1. Drain coolant.
2. Using hose clamp pliers, disconnect both hose clamps on each hose.
3. Remove the coolant inlet hose from each fitting.
4. Remove the coolant outlet hose.

Table 4. FPP Replacement Procedure (Continued)

Step	Action	Value(s)	Yes	No
9	<ul style="list-style-type: none"> <li>Turn the ignition key to the <b>OFF</b> position.</li> <li>Connect the governor motor wire harness connector.</li> </ul> <p>Is the governor motor wire harness connector connected?</p>		Go to step 10.	
10	<ul style="list-style-type: none"> <li>Remove all test equipment except the laptop computer.</li> <li>Connect any disconnected components, fuses, etc.</li> <li>Using the laptop computer, clear DTC information from the ECM.</li> <li>Turn the ignition <b>OFF</b> and wait 30 seconds.</li> <li>Start the engine and operate the vehicle to full operating temperature.</li> <li>Observe the MIL.</li> <li>Observe engine performance and driveability.</li> </ul> <p>Does the engine operate normally with no stored codes?</p>		System OK.	Go to On-Board Diagnostics System Check in the section <b>Electronic Control Module (ECM) Diagnostic Troubleshooting, GM 3.0L and 4.3L EPA Compliant Engines 2200 YRM 1090.</b>

**ELECTRONIC CONTROL MODULE (ECM) REPLACEMENT**

**Remove**

1. Disconnect negative battery cable.
2. Remove ECM from mounting bracket.
3. Push connector lock back to unlock connector.
4. Unplug ECM and remove.

**Install**




**CAUTION**

The ECM is calibrated for each engine. Verify you have the correct ECM.

1. Plug connector into ECM.

2. Push lock into place.
3. Mount ECM into mounting bracket.
4. Connect the battery cable.
5. Connect the laptop computer and check for DTC codes or MIL lights. See the section **Electronic Control Module (ECM) Diagnostic Troubleshooting, GM 3.0L and 4.3L EPA Compliant Engines 2200 YRM 1090.**
6. Start engine.
7. Check for any DTC codes and clear them.
8. Verify engine is in closed loop and no MIL lights are present.

Table 11. No Start (Continued)

Checks	Action
Engine Mechanical Checks	 <b>CAUTION</b> <b>The LPG fuel system works on a fumigation principle of fuel introduction and is more sensitive to intake manifold leakage than the gasoline fuel supply system.</b> <ul style="list-style-type: none"> <li>• Check for the following: <ul style="list-style-type: none"> <li>– Vacuum leaks</li> <li>– Improper valve timing</li> <li>– Low compression</li> <li>– Bent pushrods</li> <li>– Worn rocker arms</li> <li>– Broken or weak valve springs</li> <li>– Worn camshaft lobes.</li> </ul> </li> </ul>
Exhaust System Checks	<ul style="list-style-type: none"> <li>• Check the exhaust system for a possible restriction: <ul style="list-style-type: none"> <li>– Inspect the exhaust system for damaged or collapsed pipes.</li> <li>– Inspect the muffler for signs of heat distress or for possible internal failure.</li> </ul> </li> <li>• Check for possible plugged catalytic converter. Refer to Restricted Exhaust System Diagnosis.</li> </ul>

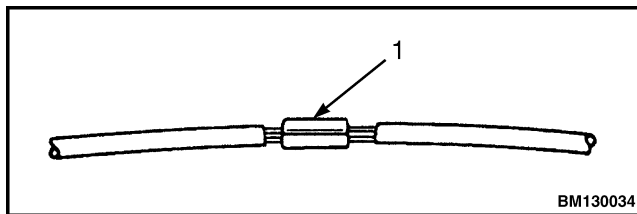
## Wire Harness Repair

### ON VEHICLE SERVICE WIRING HARNESS REPAIR

**NOTE:** The most common fault that occurs in an electronic engine control system is caused by a bad connection in the wiring. Work carefully and make sure that connectors are not damaged during troubleshooting.

The ECM wire harness electrically connects the ECM to solenoids, switches, and sensors in the engine and passenger compartment. A wiring harness must be replaced with a wire harness that has the same part number. If a repair (wire splice) must be made to a wiring harness, replacement wire must have a high-temperature insulation.

The signal wires in the electronic control system have a low voltage and low current. All splice wires must be high quality so that a fault is not made in the circuit by the wire splice. Use solder on the wire splices when possible. See Figure 36.



#### 1. SPLICE AND SOLDER

**Figure 36. Splice and Solder**

Some connectors are made as a one-piece unit. A damaged one-piece connector must be replaced with a wire splice into the wiring harness. Some connectors can be replaced or a terminal within the connectors can be replaced. These connectors are described in the paragraphs under Connectors and Terminals.

### CONNECTORS AND TERMINALS



#### CAUTION

Use care when probing a connector or replacing terminals in them. It is possible to short between opposite terminals. If this happens to the wrong terminal pair, it is possible to damage certain components. Always use jumper wires between connectors for circuit checking. NEVER probe through the Weather-Pack seals.

Be careful when using a probe to check the voltages on the terminals in a connector. It is easy to cause a short circuit between two terminals with opposite voltages. Electronic components can be easily damaged by a short circuit. Always use a **Jumper With A 15 Amp Fuse** between connectors when checking circuits. Never damage the insulation or a seal on a connector when making a check or doing troubleshooting. The **Connector Test Adapter Kit** has a variation of adapters and connectors that can be used when troubleshooting a circuit.

When Troubleshooting, open circuits are often difficult to see because of dirt, corrosion, or a terminal that is not in alignment in its socket. When Troubleshooting for an open circuit, always check for loose connections and a terminal that can have corrosion. A fault that is not regular nor constant can also be caused by a loose connection or a terminal that has corrosion.

Always verify the type of connector to be repaired. Some smaller models of connectors look similar but have a different construction.

4. Start Windows.
5. From the Start menu select Programs.
6. Select IMPCO Display.
7. Place the ignition key in the **ON** position.
8. The system Gauge screen should now appear and a green banner in the upper left hand will read Connected.

power schematic. Also check for +12 switched power at ECM pin 21 with the ignition key on.

3. Check for power at the diagnostic link connector for +5-volts between pins C (LT GRN/RED) and pin D (BLK) with the ignition key in the on position.

### Diagnostic Communication Error

The ECM 5-volt reference circuit powers the Spectrum diagnostic link cable. In the event that the 5-volt reference signal is open or shorted to ground, you will not be able to connect to the system. If you are unable to connect, follow the quick checks listed below:

You may still be able to retrieve a code using the blink code function of the MIL if none of the above recommendations prove useful. In the event of a 5-volt reference signal malfunction, DTC 531-External 5V Ref Lower Than Expected or DTC 532-External 5 V Ref Higher Than Expected should set. If you find one of these codes using the blink code function of the MIL, follow the DTC diagnostic chart recommendations in the DTC section of this manual.

1. Be sure you are using the correct password and latest software for the system you are connecting to.
2. Check the ECM system power and ground circuits. Refer to DTC 261 - System Voltage Low for the

### DIAGNOSTIC TROUBLE CODES

The System Fault screen is used to view and clear DTCs, which have been set. See Figure 1.

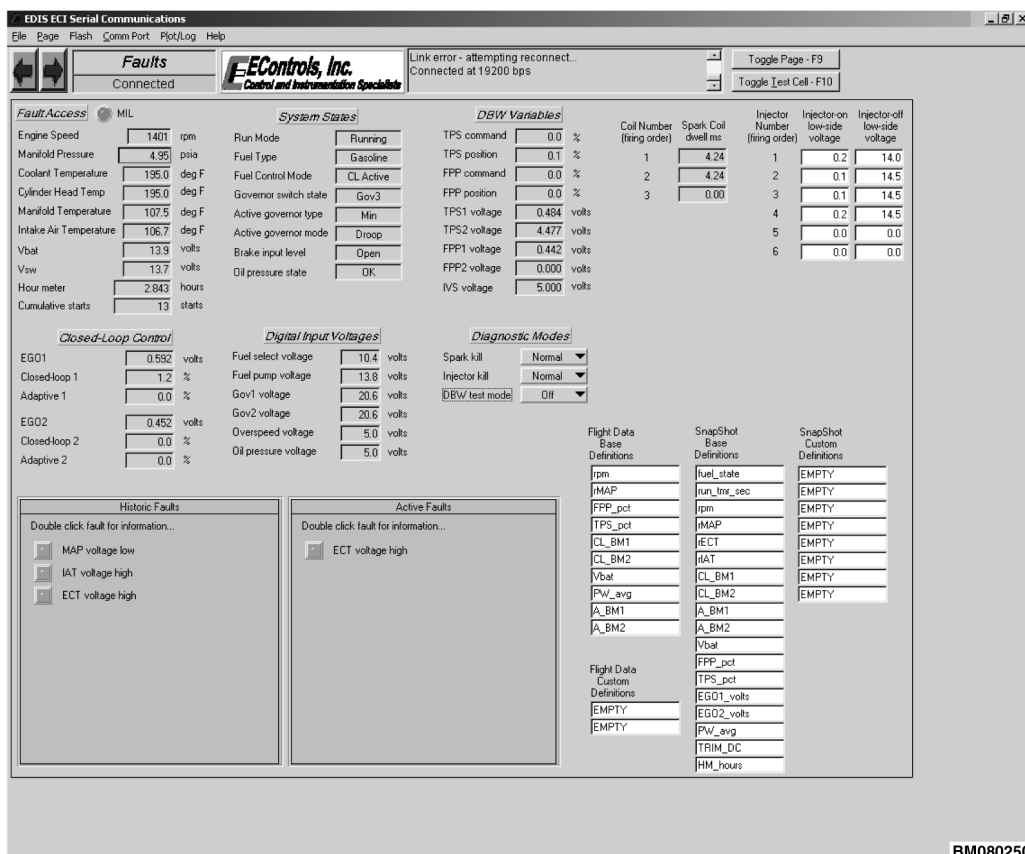
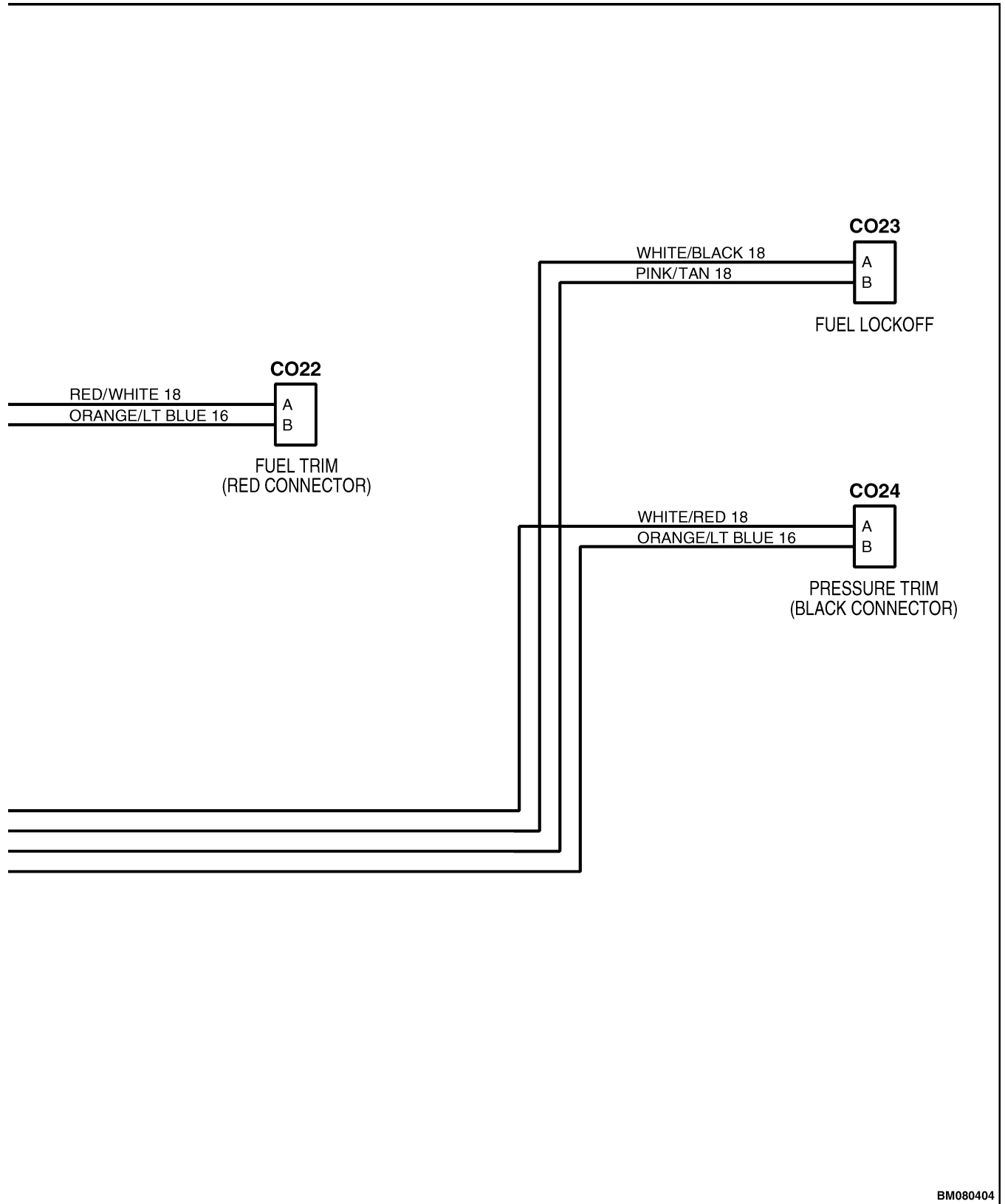
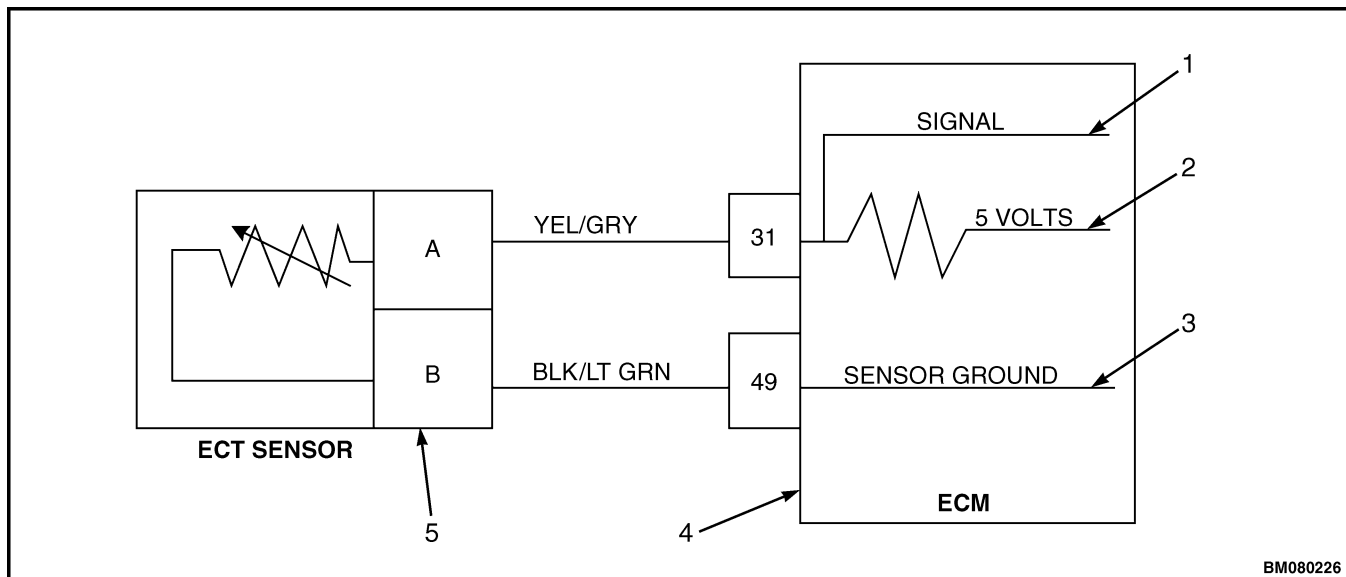


Figure 1. System Fault Screen



BM080404

Figure 9. 3.0L LPG Jump Harness



BM080226

- 1. SIGNAL
- 2. 5 VOLTS
- 3. SENSOR GROUND
- 4. ELECTRONIC CONTROL MODULE (ECM)
- 5. ENGINE COOLANT TEMPERATURE (ECT) SENSOR

Figure 19. ECT Sensor Circuit

Table 35. DTC 123 - ECT Higher Than Expected 1

Step	Action	Value(s)	Yes	No
1	Did you perform the On-board diagnostics (OBD) system check?		Go to step 2.	Go to On-Board Diagnostics System Check/Malfunction Indicator Lamp.
2	<ul style="list-style-type: none"> <li>• Key <b>ON</b>.</li> <li>• Laptop computer connected in system data mode.</li> <li>• Warm engine to normal operating temperature, then run the engine above 1000 rpm for 60 seconds.</li> </ul> <p>Does laptop computer display ECT temperature of 104°C (220°F) or greater, with the engine running over 500 rpm?</p>		Go to step 3.	Intermittent problem. Go to Preliminary and Intermittent Checks.
3	<ul style="list-style-type: none"> <li>• Verify with a temperature gauge that the engine coolant is over 107.2°C (225°F).</li> </ul> <p>Does the temperature gauge indicate 107.2°C (225°F) or greater?</p>		Repair the cooling system.	Go to step 4.
4	Verify ECT circuit function. Follow diagnostic test procedure for DTC 122 - ECT Voltage Low.			

Table 43. DTC 144 - Camshaft Sensor Loss (Continued)

Step	Action	Value(s)	Yes	No
3	<ul style="list-style-type: none"> <li>Key <b>ON</b> and engine <b>OFF</b>.</li> <li>Disconnect the CMP sensor connector C006.</li> <li>Using a DVOM, check for voltage at the CMP sensor connector pin B and engine ground.</li> </ul> <p>Do you have voltage?</p>	5.0 volts	Go to step 4.	Repair the circuit as necessary. Refer to Wire Harness Repair. Go to step 11.
4	<ul style="list-style-type: none"> <li>Key <b>OFF</b>.</li> <li>Disconnect ECM connector C001.</li> <li>Using a DVOM, check for continuity between CMP connector pin A and ECM connector pin 14.</li> </ul> <p>Do you have continuity between them?</p>		Go to step 5.	Repair the circuit as necessary. Refer to Wire Harness Repair. Go to step 11.
5	<ul style="list-style-type: none"> <li>Using a DVOM, check for continuity between CMP connector pin B and ECM connector pin 50.</li> </ul> <p>Do you have continuity between them?</p>		Go to step 6.	Repair the circuit as necessary. Refer to Wire Harness Repair. Go to step 11.
6	<ul style="list-style-type: none"> <li>Inspect the CMP connector C006 terminals for damage, corrosion or contamination.</li> </ul> <p>Did you find a problem?</p>		Repair the circuit as necessary. Refer to Wire Harness Repair. Go to step 11.	Go to step 7.
7	<ul style="list-style-type: none"> <li>Inspect the ECM connector C001 terminals 13, 14, and 50 for damage, corrosion or contamination</li> </ul> <p>Did you find a problem?</p>		Repair the circuit as necessary. Refer to Wire Harness Repair. Go to step 11.	Go to step 8.
8	<ul style="list-style-type: none"> <li>Replace CMP sensor. Pay special attention to CMP sensor reluctor wheel inspection.</li> </ul> <p>Is the replacement complete?</p>		Go to step 10.	
9	<ul style="list-style-type: none"> <li>Replace the ECM.</li> </ul> <p>Is the replacement complete?</p>		Go to step 11.	

**IAT sensor** - check for a shifted sensor that could cause the ECM to sense lower than actual temperature of incoming air. This can cause a rich exhaust condition.

**ECT sensor** - check for a skewed sensor that could cause the ECM to sense engine temperature colder than it actually is. This could also cause a rich exhaust condition.

**Table 51. DTC 242 - Adaptive Rich Fault (Low Limit-Gasoline)**

Step	Action	Value(s)	Yes	No
1	<ul style="list-style-type: none"> <li>Perform the On-board (OBD) system check.</li> </ul> <p>Are any other DTCs present?</p>		Go to step 3.	Go to step 2.
2	<p>Visually and physically check the following items:</p> <ul style="list-style-type: none"> <li>The air intake duct for being collapsed or restricted.</li> <li>The air filter for being plugged.</li> <li>The HO<sub>2</sub>S sensor installed securely and the wire leads not contacting the exhaust manifold or ignition wires.</li> <li>ECM grounds for being clean and tight. Refer to GM 3.0L Wiring Schematics and Connectors.</li> <li>Fuel system diagnostics. Refer to the section <b>Electronic Controlled LPG/Gasoline Fuel System, GM 3.0L and 4.3L EPA Compliant Engines 900 YRM 1088.</b></li> </ul> <p>Was a repair made?</p>		Go to step 6.	Go to step 4.
3	<ul style="list-style-type: none"> <li>Diagnose any other DTC codes before proceeding with this chart.</li> </ul> <p>Have any other DTC codes been detected, diagnosed and repaired?</p>		Go to step 6.	Go to step 4.
4	<ul style="list-style-type: none"> <li>Key <b>OFF</b>.</li> <li>Disconnect HO<sub>2</sub>S sensor wire harness connector.</li> <li>Disconnect ECM wire harness connector.</li> <li>Key <b>ON</b>.</li> <li>Using a DVOM, check for voltage at HO<sub>2</sub>S connector signal pin B and engine ground.</li> </ul> <p>Do you have voltage?</p>		Repair the circuit as necessary. Refer to Wire Harness Repair. Go to step 6.	Go to step 5.

## DTC 513 - A/D LOSS

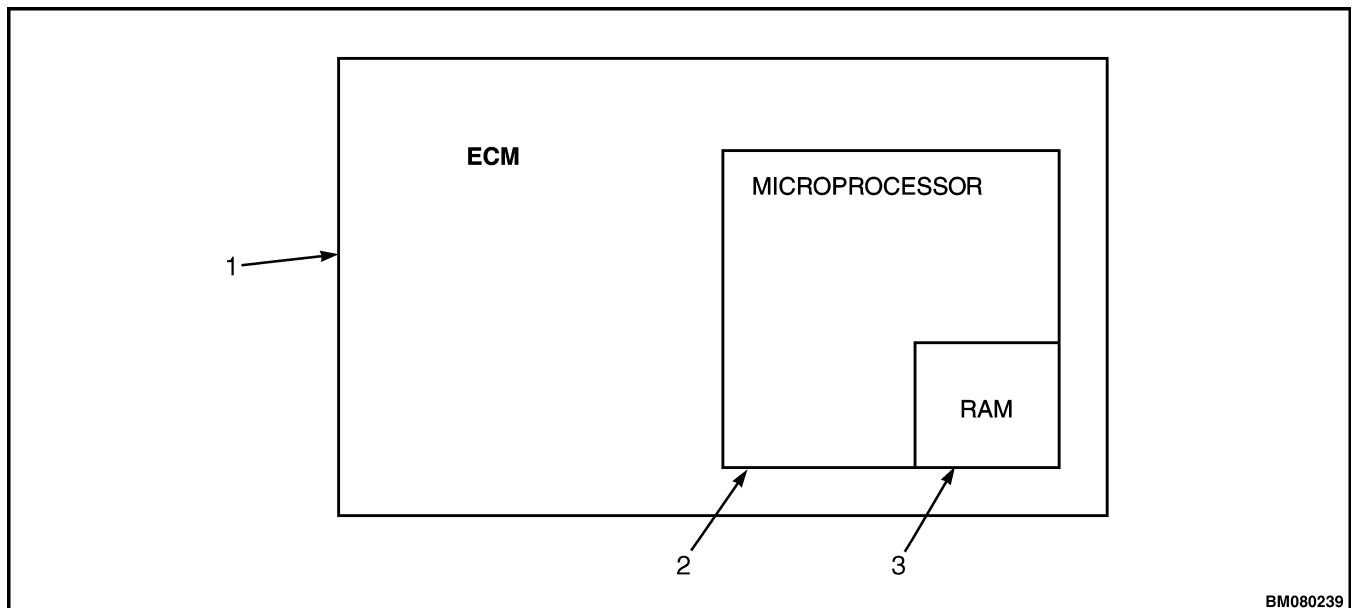
### Circuit Description

The ECM has checks that must be verified each time an instruction is executed. Several different things can happen within the microprocessor that will cause this fault. The ECM will reset itself in the event this fault is set, and the MIL will be on until the code is cleared. This fault should be erased after diagnosis by removing battery power. It will not self-erase. See Figure 44.

During this active fault, power derate (level 2) will be enforced. When this is enforced, maximum throttle position will be 20 percent. This is enforced until the fault is manually cleared.

### Conditions for Setting the DTC

- Electronic control module.
- Check condition - key **ON**.
- Fault condition - internal microprocessor error.
- MIL - on until code is cleared by technician.
- Adaptive - disabled for the remainder of the key **ON** cycle.
- Closed loop - enabled.
- Power Derate - level 2 until fault is cleared manually.



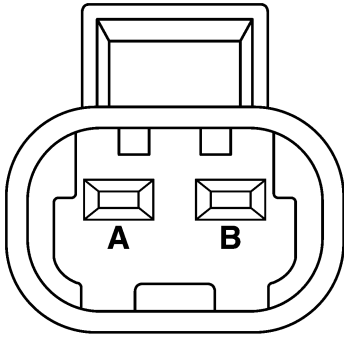
1. ELECTRONIC CONTROL MODULE (ECM)
2. MICROPROCESSOR
3. RAM

*Figure 44. ECM Microprocessor*

Table 69. DTC 612 - FPP Low Voltage (Continued)

Step	Action	Value(s)	Yes	No
8	<ul style="list-style-type: none"> <li>Check FPP connector wire terminals for damage, corrosion or contamination.</li> </ul> <p>Did you find a problem?</p>		Repair the circuit as necessary. Refer to Wire Harness Repair. Go to step 18.	Go to step 6.
9	<ul style="list-style-type: none"> <li>Probe FPP connector signal circuit pin C with a test light connected to battery voltage.</li> </ul> <p>Does the laptop computer display FPP voltage of 4.8 volts or greater?</p>		Go to step 10.	Go to step 14.
10	<ul style="list-style-type: none"> <li>Key <b>OFF</b>.</li> <li>Disconnect ECM wire harness connector.</li> <li>Using a DVOM, check for continuity between FPP sensor connector 5-volt reference pin A and ECM connector 5-volt reference pin 50.</li> </ul> <p>Do you have continuity between them?</p>		Go to step 11.	Repair the circuit as necessary. Refer to Wire Harness Repair. Go to step 18.
11	<ul style="list-style-type: none"> <li>Using A DVOM, check for continuity between ECM 5-volt reference pin 50 and engine ground.</li> </ul> <p>Do you have continuity between them?</p>		Repair the circuit as necessary. Refer to Wire Harness Repair. Go to step 18.	Go to step 12.
12	<ul style="list-style-type: none"> <li>Using a DVOM, check for continuity between ECM connector 5-volt reference pin 50 and ECM sensor ground pin 49.</li> </ul> <p>Do you have continuity between them?</p>		Repair the circuit as necessary. Refer to Wire Harness Repair. Go to step 18.	Go to step 13.
13	<ul style="list-style-type: none"> <li>Inspect FPP and ECM connector terminal terminals for damage, corrosion or contamination.</li> </ul> <p>Did you find a problem?</p>		Repair the circuit as necessary. Refer to Wire Harness Repair. Go to step 18.	Go to step 17.
14	<ul style="list-style-type: none"> <li>Key <b>OFF</b>.</li> <li>Disconnect ECM wire harness connector C001.</li> <li>Using a DVOM, check for continuity between FPP connector signal pin C and ECM connector FPP signal pin 38.</li> </ul> <p>Do you have continuity between them?</p>		Go to step 15.	Repair the circuit as necessary. Refer to Wire Harness Repair. Go to step 18.

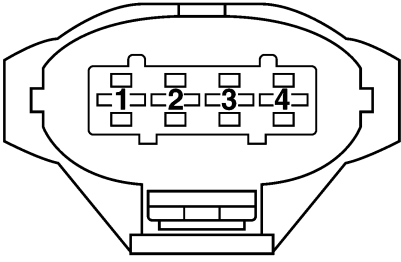
**Table 87. Throttle Connector C012**



BM080381

Pin	Wire Color	Function
1	Tan/Orange	DBW -
2	Pink/White	DBW +

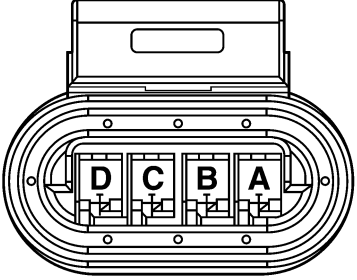
**Table 88. Bosch TMAP Connector C013 (Gasoline Fuel System Only)**



BM080382

Pin	Wire Color	Function
1	Black/Light Green	Analog Return
2	Tan	IAT
3	Light Green/Red	5 Volt Reference
4	Light Green	MAP

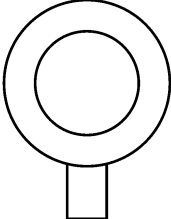
**Table 89. Motorola TMAP Connector C013 (LPG Fuel System Only)**



BM080626

Pin	Wire Color	Function
A	Black/Light Green	Analog Return
B	Tan	IAT
C	Light Green/Red	5 Volt Reference
D	Light Green	MAP

**Table 90. Starter Solenoid Connector C014**



BM080374

Pin	Wire Color	Function
A	White	Starter Relay

## DTC 112 - IAT LOW VOLTAGE MOTOROLA® TMAP

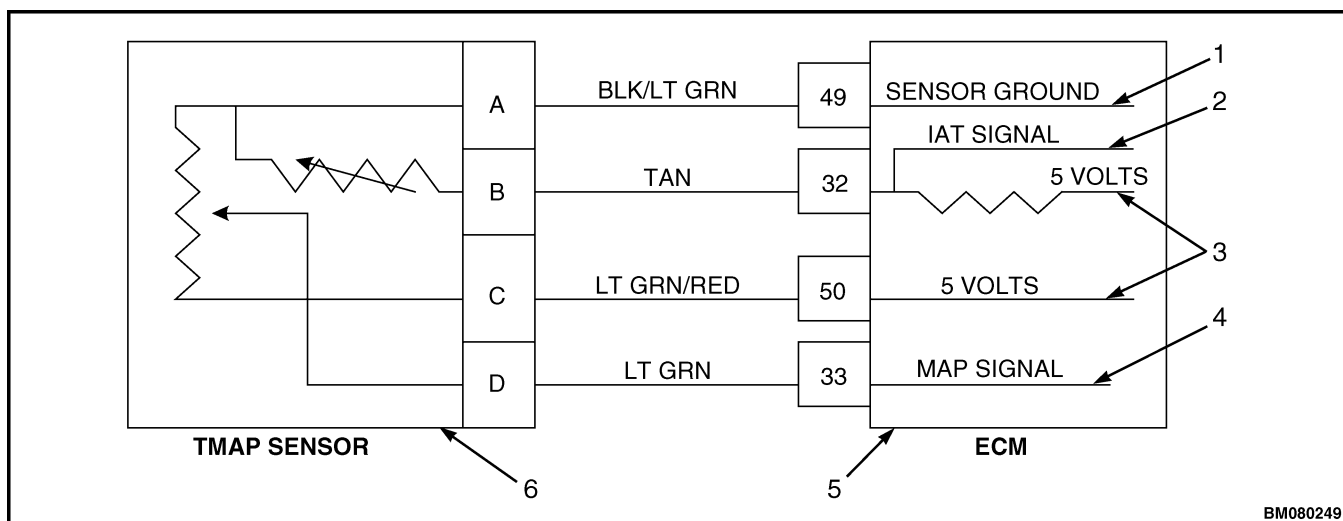
### Circuit Description

The TMAP is a combined intake air temperature (IAT) and manifold absolute pressure (MAP) sensor. A temperature-sensitive resistor is used in the TMAP located in the intake manifold of the engine. It is used to monitor incoming air temperature; and the output, in conjunction with other sensors, is used to determine the airflow to the engine. The ECM provides a voltage divider circuit so that when the air is cool, the signal reads higher voltage, and lower when warm. The IAT is a calculated value based mainly on the IAT sensor at high airflow, and influenced more by the engine coolant temperature (ECT) at low airflow. See Figure 67.

This fault will set if the signal voltage is less than 0.05 volts for 1 second anytime the engine is cranking or running. The ECM will use the default value for the IAT sensor in the event of this fault.

### Conditions for Setting the DTC

- Intake air temperature.
- Check condition - engine cranking or running.
- Fault condition - IAT sensor voltage less than 0.05 volts for 1 second.
- MIL - on during active fault and for 2 seconds after active fault.
- Adaptive - disabled during active fault.



1. SENSOR GROUND
2. INTAKE AIR TEMPERATURE (IAT) SIGNAL
3. 5 VOLTS
4. MANIFOLD ABSOLUTE PRESSURE (MAP) SIGNAL
5. ELECTRONIC CONTROL MODULE (ECM)
6. TEMPERATURE MANIFOLD ABSOLUTE PRESSURE (TMAP) SENSOR

**Figure 67. TMAP Sensor Circuit**

Table 121. DTC 131 - MAP High Pressure (Bosch® TMAP) (Continued)

Step	Action	Value(s)	Yes	No
10	<ul style="list-style-type: none"> <li>Correct TMAP mechanical connection.</li> </ul> <p>Has TMAP mechanical connection been corrected?</p>		Go to step 11.	
11	<ul style="list-style-type: none"> <li>Remove all test equipment except the laptop computer.</li> <li>Connect any disconnected components, fuses, etc.</li> <li>Using the laptop computer, clear DTC information from the ECM.</li> <li>Turn the ignition <b>OFF</b> and wait 30 seconds.</li> <li>Start the engine and operate the vehicle to full operating temperature.</li> <li>Observe the MIL.</li> <li>Observe engine performance and driveability.</li> <li>After operating the engine within the test parameters of DTC 131, check for any stored codes.</li> </ul> <p>Does the engine operate normally with no stored codes?</p>		System OK.	Go to On-Board Diagnostics System Check/Malfunction Indicator Lamp.

Table 128. DTC 135 - BP Low Pressure (Motorola® TMAP) (Continued)

Step	Action	Value(s)	Yes	No
17	<ul style="list-style-type: none"> <li>Replace TMAP sensor.</li> </ul> <p>Is the replacement complete?</p>		Go to step 18.	
18	<ul style="list-style-type: none"> <li>Remove all test equipment except the laptop computer.</li> <li>Connect any disconnected components, fuses, etc.</li> <li>Using the laptop computer, clear DTC information from the ECM.</li> <li>Turn the ignition <b>OFF</b> and wait 30 seconds.</li> <li>Start the engine and operate the vehicle to full operating temperature.</li> <li>Observe the MIL.</li> <li>Observe engine performance and driveability.</li> <li>After operating the engine within the test parameters of DTC 135 check for any stored codes.</li> </ul> <p>Does the engine operate normally with no stored codes?</p>		System OK.	Go to On-Board Diagnostics System Check/Malfunction Indicator Lamp.



## DTC 512 - INVALID INTERRUPT

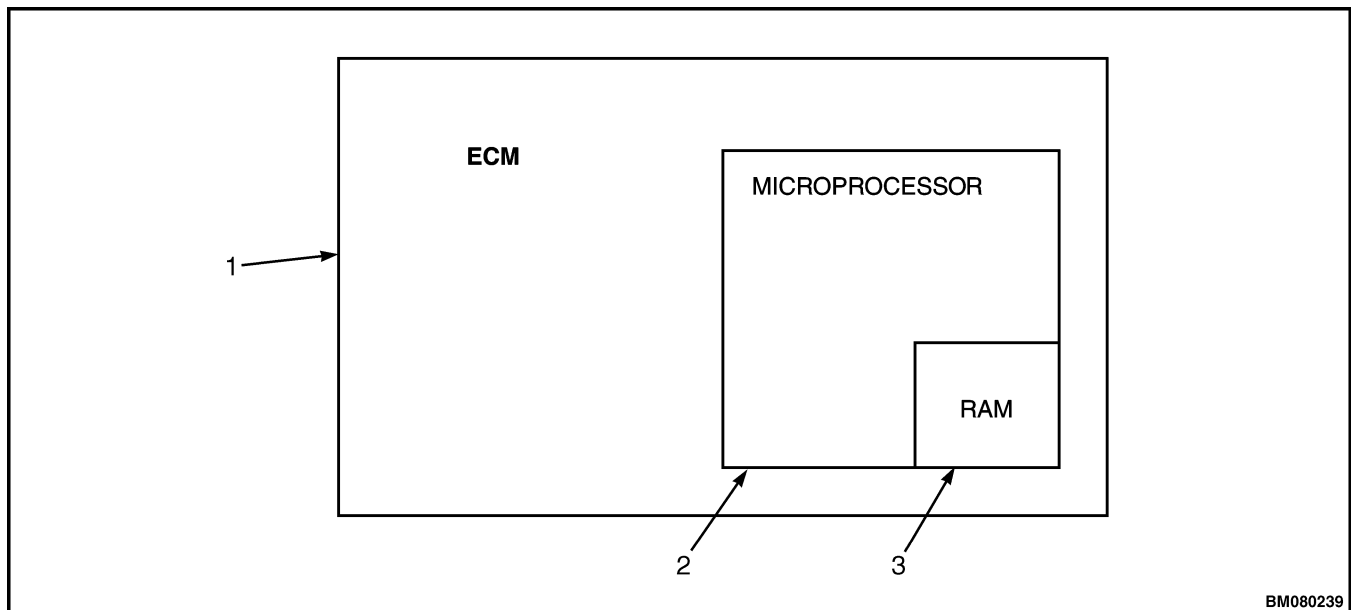
### Circuit Description

The ECM has checks that must be verified each time an instruction is executed. Several different things can happen within the microprocessor that will cause this fault. The ECM will reset itself in the event this fault is set, and the MIL will be on until the code is cleared. This fault should be erased after diagnosis by removing battery power. It will not self-erase. See Figure 101.

During this active fault, power derate (level 2) will be enforced. When this is enforced, maximum throttle position will be 20 percent. This is enforced until the fault is manually cleared.

### Conditions for Setting the DTC

- Electronic control module.
- Check condition - key **ON**.
- Fault condition - internal microprocessor error.
- MIL - on until code is cleared by technician.
- Adaptive - disabled for the remainder of the key **ON** cycle.
- Closed loop - enabled.
- Power derate - level 2 until fault is cleared manually.



1. ELECTRONIC CONTROL MODULE (ECM)
2. MICROPROCESSOR
3. RAM

*Figure 101. ECM Microprocessor*

Table 154. DTC 611 - FPP High Voltage (Continued)

Step	Action	Value(s)	Yes	No
14	<ul style="list-style-type: none"> <li>• Key <b>OFF</b>.</li> <li>• Disconnect ECM connector.</li> <li>• Check continuity between FPP sensor connector ground pin B and ECM connector FPP sensor ground pin 49.</li> </ul> <p>Do have continuity between them?</p>		Go to step 10.	Repair the circuit as necessary. Refer to Wire Harness Repair. Go to step 15.
15	<ul style="list-style-type: none"> <li>• Remove all test equipment except the laptop computer.</li> <li>• Connect any disconnected components, fuses, etc.</li> <li>• Using the laptop computer clear DTC information from the ECM.</li> <li>• Turn the ignition <b>OFF</b> and wait 30 seconds.</li> <li>• Start the engine and operate the vehicle to full operating temperature.</li> <li>• Observe the MIL.</li> <li>• Observe engine performance and driveability.</li> <li>• After operating the engine within the test parameters of DTC 611, check for any stored codes.</li> </ul> <p>Does the engine operate normally with no stored codes?</p>		System OK.	Go to On-Board Diagnostics System Check/Malfunction Indicator Lamp.

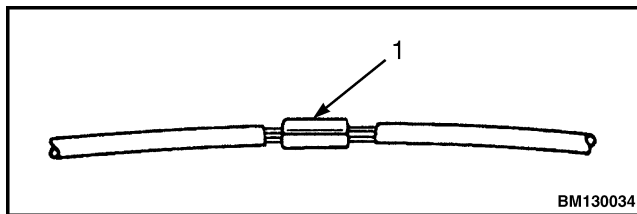
## Wire Harness Repair

### ON VEHICLE SERVICE WIRING HARNESS REPAIR

**NOTE:** The most common fault that occurs in an electronic engine control system is caused by a bad connection in the wiring. Work carefully and make sure that connectors are not damaged during troubleshooting.

The ECM wire harness electrically connects the ECM to solenoids, switches, and sensors in the engine and passenger compartment. A wiring harness must be replaced with a wire harness that has the same part number. If a repair (wire splice) must be made to a wiring harness, replacement wire must have a high-temperature insulation.

The signal wires in the electronic control system have a low voltage and low current. All splice wires must be high quality so that a fault is not made in the circuit by the wire splice. Use solder on the wire splices when possible. See Figure 118.



#### 1. SPLICE AND SOLDER

**Figure 118. Splice and Solder**

Some connectors are made as a one-piece unit. A damaged one-piece connector must be replaced with a wire splice into the wiring harness. Some connectors can be replaced or a terminal within the connectors can be replaced. These connectors are described in the paragraphs under Connectors and Terminals.

### CONNECTORS AND TERMINALS

#### CAUTION

Use care when probing a connector or replacing terminals in them. It is possible to short between opposite terminals. If this happens to the wrong terminal pair, it is possible to damage certain components. Always use jumper wires between connectors for circuit checking. NEVER probe through the Weather-Pack seals.

Be careful when using a probe to check the voltages on the terminals in a connector. It is easy to cause a short circuit between two terminals with opposite voltages. Electronic components can be easily damaged by a short circuit. Always use a **Jumper With A 15 Amp Fuse** between connectors when checking circuits. Never damage the insulation or a seal on a connector when making a check or doing troubleshooting. The **Connector Test Adapter Kit** has a variation of adapters and connectors that can be used when troubleshooting a circuit.

When Troubleshooting, open circuits are often difficult to see because of dirt, corrosion, or a terminal that is not in alignment in its socket. When Troubleshooting for an open circuit, always check for loose connections and a terminal that can have corrosion. A fault that is not regular nor constant can also be caused by a loose connection or a terminal that has corrosion.

Always verify the type of connector to be repaired. Some smaller models of connectors look similar but have a different construction.

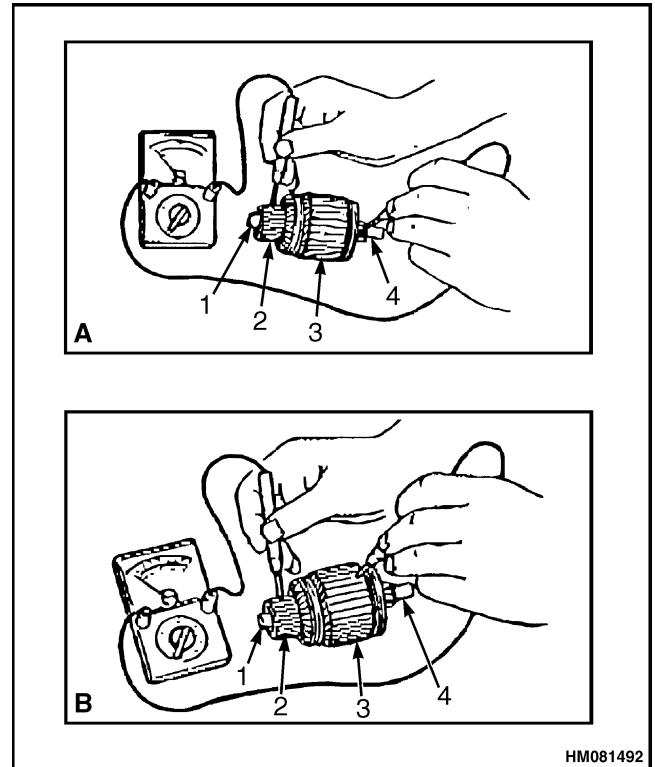
**NOTE:** Be aware that the thrust ball and packing may come out of the gear shaft assembly when the following step is performed.

5. Remove the armature and yoke assembly from the front cover.
6. Remove the armature from the yoke.
7. If the packing and thrust ball did not come out of the gear shaft assembly in Step 5, remove them from the gear shaft assembly.
8. Remove the three planetary gears from inside the internal gear.
9. Remove the lever cover and disk from the front cover.
10. Remove the pinion set from the front cover.
11. Remove the lever from the pinion set.

## INSPECT

### Armature

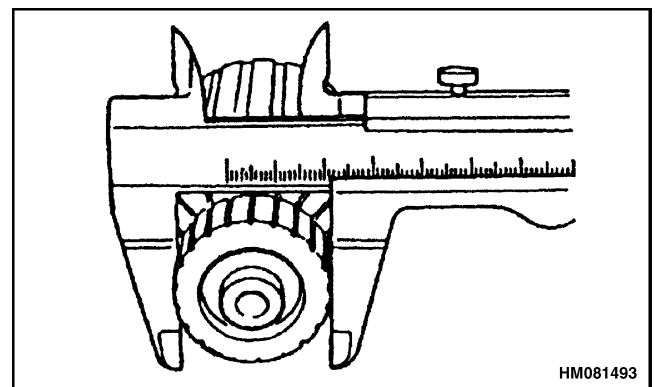
1. Using an ohmmeter, check for continuity between the commutator and shaft, and between the commutator and core. See Figure 14. If there is continuity, the commutator is grounded. Replace the armature.
2. Measure the commutator diameter. See Figure 15. Standard diameter is 29.4 mm (1.16 in.), and minimum diameter is 28.8 mm (1.13 in.). If the commutator is not within these measurements, replace the armature.
3. Check the surface of the commutator for any damage, and inspect the depth of the mica. See Figure 16. The standard depth of the mica is 0.5 to 0.8 mm (0.02 to 0.03 in.). Undercut the grooves to the standard depth if the measurement is 0.2 mm (0.008 in.) or less.



- A.** COMMUTATOR/SHAFT CHECK  
**B.** COMMUTATOR/CORE CHECK

- |               |          |
|---------------|----------|
| 1. ARMATURE   | 3. CORE  |
| 2. COMMUTATOR | 4. SHAFT |

**Figure 14. Armature Inspection**



**Figure 15. Armature Diameter Check**

## General

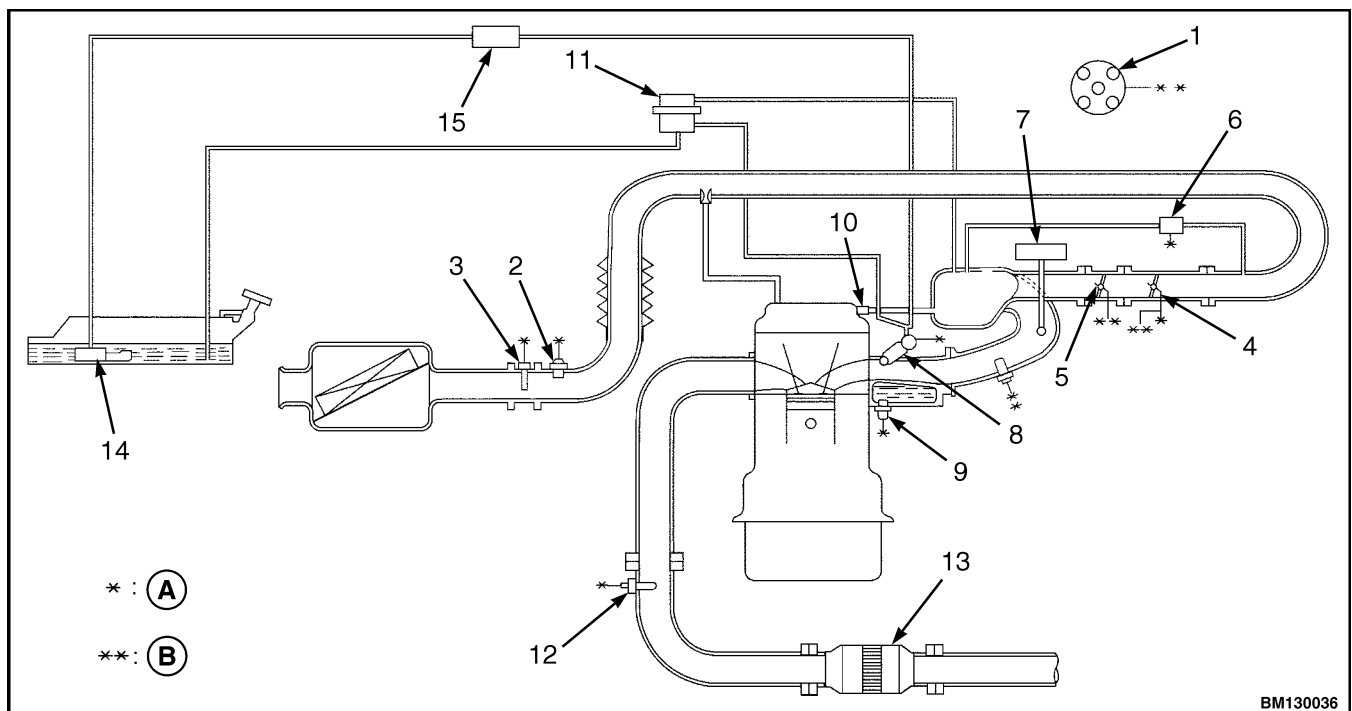
This section has the description, operation, repair procedures, and the electronic troubleshooting procedures for the engine control unit (ECU) controlling the idle, fuel, spark, and timing for the Mazda 2.0L and 2.2L EPA and CARB compliant gasoline engines. For the description and operation of the diagnostic tools and

electronic troubleshooting procedures for the electronic control module (ECM) controlling the governor, refer to the section **Governor Electronic Control Module (ECM) Diagnostic Troubleshooting, Mazda 2.0L and 2.2L EPA and CARB Compliant Engines 2200 YRM 1092.**

## Description of Operation

An engine control unit (ECU) has been adopted on the gasoline fuel system, with an electronic centralized control of the ignition and fuel injection timing. Based on the adoption of the ECU, the electronic gasoline injection

(EGI) system has been adopted on the gasoline fuel system, and the electronic spark advance (ESA) system has been adopted on the ignition system. See Figure 1.



### A. TO ENGINE CONTROL UNIT (ECU)

1. CAMSHAFT POSITION (CMP) SENSOR (INTEGRATED IN THE DISTRIBUTOR)
2. INTAKE AIR TEMPERATURE (IAT) SENSOR
3. MASS AIR FLOW (MAF) SENSOR
4. THROTTLE POSITION (TP) SENSOR
5. ELECTRONIC GOVERNOR SENSOR AND MOTOR (ELECTRONIC GOVERNOR ASSEMBLY)
6. IDLE AIR CONTROL (IAC) VALVE
7. BOOST SENSOR

### B. TO GOVERNOR CONTROL UNIT (GCU)

8. FUEL INJECTOR
9. ENGINE COOLANT TEMPERATURE (ECT) SENSOR
10. POSITIVE CRANKCASE VENTILATION (PCV) VALVE
11. PRESSURE REGULATOR
12. HEATED OXYGEN SENSOR (HO<sub>2</sub>S)
13. THREE WAY CATALYTIC (TWC) CONVERTER
14. FUEL PUMP
15. FUEL FILTER

**Figure 1. Control System Diagram**

Table 8. Service Codes (Continued)

Service Code	Diagnosis Category	MIL	DC <sup>*1</sup>	PC <sup>*2</sup>	FFD <sup>*3</sup>	Memory Function	Diagnosis Outcome
P0134	HO <sub>2</sub> S signals (Inactive)	ON	2	Yes	Yes	Yes	Refer to Service Code P0134 HO <sub>2</sub> S Signals: Inactive.
P0171	Fuel injection control system (A/F ratio lean)	ON	2	Yes	Yes	Yes	Refer to Service Code P0171 Fuel Injection Control System: A/F Ratio Lean.
P0172	Fuel injection control system (A/F ratio rich)	ON	2	Yes	Yes	Yes	Refer to Service Code P0172 Fuel Injection Control System: A/F Rich.
P0340	CMP sensor signals	ON	1	-	Yes	Yes	Refer to Service Code P0340 CMP Sensor Signals.
P1504	IAC valve	ON	1	-	Yes	Yes	Refer to Service Code P1504 IAC System.
P1562	Battery backup power supply	ON	1	-	Yes	Yes	Refer to Service Code P1562 Battery Backup Power Supply.
P1608	ECU internal circuit failure	-	-	-	-	-	Refer to Service Code P1608 ECU Internal Circuit Breakage.
<sup>*1</sup> : Drive Cycle (DC) <sup>*2</sup> : Pending Code (PC) <sup>*3</sup> : Freeze Frame Data (FFD)							

## Service Code P1504 IAC System

### FAILURE DETECTION CONDITION

**NOTE:** The threshold value depends on the battery voltage and IAC control signal duty value when detected.

- If the ECU detects that ECU 4AB terminal (IAC positive) voltage is above high-side threshold or below low-side when the IAC control duty target is above 18 percent, the ECU determines that the IAC valve circuit has a malfunction.
- If the ECU detects that ECU 4Y (IAC negative) voltage is above 2 volts, or IAC control duty target is below threshold (according to battery voltage), the ECU determines that the IAC valve circuit has a malfunction.

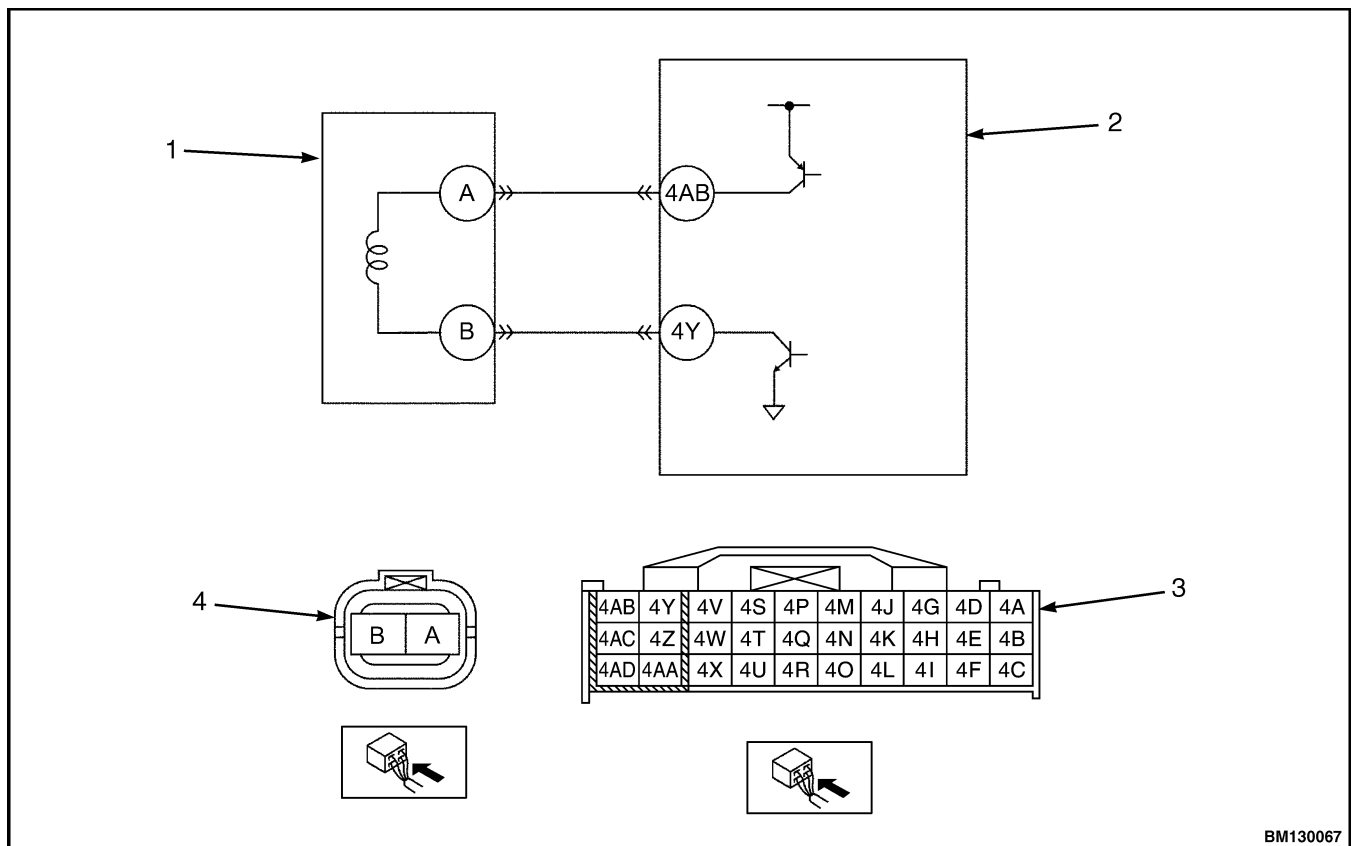
### POSSIBLE SOURCES

Refer to Figure 33 for the following:

- IAC valve circuit failure.
- Connector or terminal failure.
- Harness between the IAC valve A terminal and ECU 4AB terminal short-circuits to ground.
- Harness breakage between the IAC valve A terminal and ECU 4AB terminal.
- Harness between the IAC valve B terminal and ECU 4Y terminal short-circuits to ground.
- Harness between IAC valve B terminal and ECU 4Y terminal short-circuits to power supply system.
- Harness breakage between the IAC valve B terminal and ECU 4Y terminal.
- ECU failure.

### FAIL/SAFE

Stops IAC.



1. IAC VALVE
2. ECU

3. CONNECTOR AT ECU HARNESS SIDE
4. CONNECTOR AT IAC VALVE SIDE

Figure 33. IAC Valve Wiring Diagram

Table 18. ECU Terminal Voltage (Reference) (Continued)

Terminal	Signal	Connected to	Test condition		Voltage (V)	Action	
2V	Load correction signal	GCU	Ignition switch <b>ON</b>		Battery voltage	<ul style="list-style-type: none"> <li>Inspect GCU.</li> <li>Inspect related harness.</li> </ul>	
			Idle	Steering wheel at straight ahead position, or other	Battery voltage		
				Steering wheel fully turned, or other	Below 1.0		
2Y	Power supply	Power supply	Ignition switch <b>OFF</b>		Below 1.0	<ul style="list-style-type: none"> <li>Inspect main relay.</li> <li>Inspect related harness.</li> </ul>	
			Ignition switch <b>ON</b>		Battery voltage		
2Z	Backup power supply	Battery	Constant		Battery voltage	<ul style="list-style-type: none"> <li>Inspect related harness.</li> </ul>	
2AB	GND	Ground	Constant		Below 1.0	<ul style="list-style-type: none"> <li>Inspect related harness.</li> </ul>	
2AC	GND	Ground	Constant		Below 1.0	<ul style="list-style-type: none"> <li>Inspect related harness.</li> </ul>	
4I	Diagnostic test mode	TEST connector (TEN)	Ignition switch <b>ON</b>	Terminal Open	Battery voltage	<ul style="list-style-type: none"> <li>Inspect related harness.</li> </ul>	
				Terminal shorted	Below 1.0		
4K	IGT	Igniter	<ul style="list-style-type: none"> <li>Inspect using the wave profile. (See Using an Oscilloscope (Reference).)</li> </ul>		<ul style="list-style-type: none"> <li>Inspect igniter.</li> <li>Inspect related harness.</li> </ul>		
4Q	Fuel pump control	Fuel pump relay	Ignition switch <b>ON</b>		Battery voltage	<ul style="list-style-type: none"> <li>Inspect fuel pump relay.</li> <li>Inspect related harness.</li> </ul>	
			Cranking		Below 1.0		
			Idle		Below 1.0		
4S	MIL	GCU	Ignition switch <b>ON</b>		Below 1.0	<ul style="list-style-type: none"> <li>Inspect GCU.</li> <li>Inspect related harness.</li> </ul>	
			Idle	When normal			Battery voltage
				When malfunctioning			Below 1.0
4W	Fuel injection control (No. 1)	Fuel injector No. 1	<ul style="list-style-type: none"> <li>Inspect using the wave profile. (See Using an Oscilloscope (Reference).)</li> </ul>		<ul style="list-style-type: none"> <li>Inspect fuel injector.</li> <li>Inspect related harness.</li> </ul>		

# **GOVERNOR ELECTRONIC CONTROL MODULE (ECM) DIAGNOSTIC TROUBLESHOOTING**

**MAZDA FE AND F2 EPA AND CARB COMPLIANT ENGINES**

**GP/GLP/GDP2.00-3.00RF/TF  
(GP/GLP/GDP040-060RG/TG/ZG) [A875]**

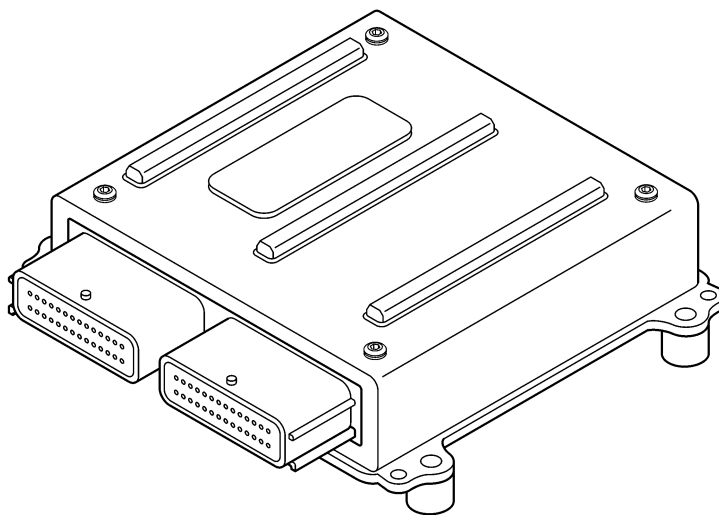


Table 6. DTC 121 - ECT Voltage High (Continued)

Step	Action	Value(s)	Yes	No
8	<ul style="list-style-type: none"> <li>Using a jumper, connect the ECT signal pin A at the ECT connector to engine ground.</li> </ul> <p>Does laptop computer display ECT voltage of 0.05 or less?</p>		Go to step 9.	Go to step 12.
9	<ul style="list-style-type: none"> <li>Key <b>OFF</b>.</li> <li>Disconnect ECM wire harness connector.</li> <li>Using a DVOM check for continuity between ECT sensor ground pin B and ECM connector pin 49.</li> </ul> <p>Do you have continuity between them?</p>		Go to step 10.	Repair the circuit as necessary. Refer to Wire Harness Repair. Go to step 14.
10	<ul style="list-style-type: none"> <li>Inspect ECM connector pins 31 and 49 for damage, corrosion, or contamination.</li> </ul> <p>Did you find a problem?</p>		Repair the circuit as necessary. Refer to Wire Harness Repair. Go to step 14.	Go to step 11.
11	<ul style="list-style-type: none"> <li>Replace the ECM.</li> </ul> <p>Is the replacement complete?</p>		Go to step 14.	
12	<ul style="list-style-type: none"> <li>Key <b>OFF</b>.</li> <li>Disconnect ECM wire harness connector.</li> <li>Using a DVOM, check for continuity between ECT connector signal pin A and ECM connector terminal 31.</li> </ul> <p>Do you have continuity between them?</p>		Go to step 13.	Repair the circuit as necessary. Refer to Wire Harness Repair. Go to step 14.

Table 14. DTC 262 - System Voltage High

Step	Action	Value(s)	Yes	No
1	Did you perform the On-board diagnostics (OBD) system check?		Go to step 2.	Go to On-Board Diagnostics System Check/Malfunction Indicator Lamp.
2	<ul style="list-style-type: none"> <li>• Key <b>ON</b> and engine running.</li> <li>• Laptop computer connected in system data mode.</li> <li>• Run engine greater than 1500 rpm.</li> </ul> <p>Does laptop computer display system voltage less than 18 volts?</p>		Intermittent problem. Go to Preliminary and Intermittent Checks.	Go to step 3.
3	<ul style="list-style-type: none"> <li>• Check voltage at battery terminals with DVOM, with engine speed greater than 1500 rpm.</li> </ul> <p>Is it greater than 18 volts?</p>		Go to step 4.	Go to step 5.
4	<ul style="list-style-type: none"> <li>• Repair the charging system.</li> </ul> <p>Has the charging system been repaired?</p>		Go to step 6.	
5	<ul style="list-style-type: none"> <li>• Replace the ECM.</li> </ul>		Go to step 6.	
6	<ul style="list-style-type: none"> <li>• Remove all test equipment except the laptop computer.</li> <li>• Connect any disconnected components, fuses, etc.</li> <li>• Using the laptop computer, clear DTC information from the ECM.</li> <li>• Turn the ignition <b>OFF</b> and wait 30 seconds.</li> <li>• Start the engine and operate the vehicle to full operating temperature.</li> <li>• Observe the MIL.</li> <li>• Observe engine performance and driveability.</li> <li>• After operating the engine within the test parameters of DTC 262, check for any stored codes.</li> </ul> <p>Does the engine operate normally with no stored codes?</p>		System OK.	Go to On-Board Diagnostics System Check/Malfunction Indicator Lamp.

Table 25. DTC 611 - FPP High Voltage

Step	Action	Value(s)	Yes	No
1	Did you perform the On-board diagnostics (OBD) system check?		Go to step 2.	Go to On-Board Diagnostics System Check/Malfunction Indicator Lamp.
2	<ul style="list-style-type: none"> <li>Key <b>ON</b> and engine <b>OFF</b>.</li> <li>Laptop computer connected in system data mode.</li> </ul> <p>Does the laptop computer display FPP voltage of 4.8 volts or greater with the foot pedal in the idle position?</p>		Go to step 8.	Go to step 3.
3	<ul style="list-style-type: none"> <li>Slowly increase FPP while observing FPP voltage.</li> </ul> <p>Does laptop computer FPP voltage ever exceed 4.8 volts?</p>		Go to step 4.	Intermittent problem. Go to Preliminary and Intermittent Checks.
4	<ul style="list-style-type: none"> <li>Key <b>OFF</b>.</li> <li>Disconnect FPP sensor connector.</li> <li>Inspect connector and wire terminals for damage, corrosion, or contamination.</li> </ul> <p>Did you find a problem?</p>		Repair the circuit as necessary. Refer to Wire Harness Repair. Go to step 15.	Go to step 5.
5	<ul style="list-style-type: none"> <li>Disconnect ECM connector C001.</li> <li>Check continuity between FPP sensor connector ground pin B and ECM connector FPP sensor ground pin 49.</li> </ul> <p>Do have continuity between them?</p>		Go to step 6.	Repair the circuit as necessary. Refer to Wire Harness Repair. Go to step 15.
6	<ul style="list-style-type: none"> <li>Key <b>ON</b>.</li> <li>Using a DVOM, check for voltage at ECM wire harness connector FPP signal pin 38 and ECM sensor ground terminal pin 49.</li> </ul> <p>Do you have voltage between them?</p>		Repair the circuit as necessary. Refer to Wire Harness Repair. Go to step 15.	Go to step 7.
7	<ul style="list-style-type: none"> <li>Using a DVOM, check for voltage at ECM wire harness connector between ECM FPP signal pin 38 and engine ground.</li> </ul> <p>Do you have voltage between them?</p>		Repair the circuit as necessary. Refer to Wire Harness Repair. Go to step 15.	Intermittent problem. Go to Preliminary and Intermittent Checks.

## DTC 636 - TPS1 Lower Than TPS2

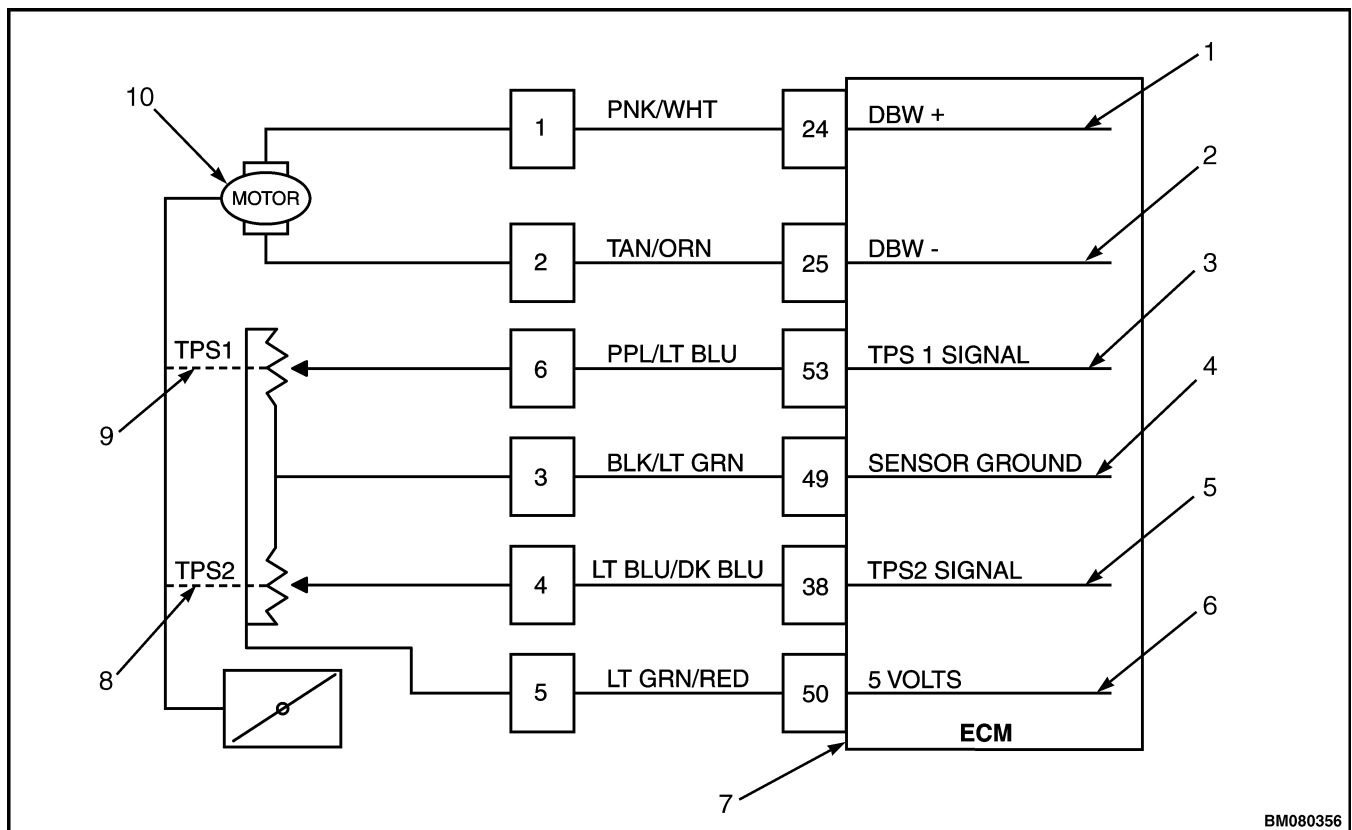
### CIRCUIT DESCRIPTION

There are two throttle position sensors located within the throttle which use variable resistors to determine signal voltage based on throttle plate position. See Figure 33. Two sensors are used for improved safety and redundancy. Both sensors read low voltage when closed and high voltage when open, but the output voltage is shifted to allow distinction between the two sensors. TPS1 will read approximately 1.7 volts lower than TPS2. The TPS1 and TPS2 percentages are calculated from these voltages. Although the voltages are different, the calculated values for the throttle position percentages should be very close to the same. The TPS values are used by the ECM to determine if the throttle is opening as commanded.

This fault will set if TPS1 is 30 percent (or more) lower than TPS2. At this point, the throttle is considered to be out of specification, or there is a problem with the TPS signal circuit. During this fault, the MIL light will be on and the engine will shut down.

### CONDITIONS FOR SETTING THE DTC

- Throttle position sensor No. 1 and No. 2.
- Check condition - key switch **ON**.
- Fault condition - TPS1 lower than TPS2 (30 percent difference or more).
- MIL - on during active fault.
- Engine shut down.



1. DRIVE BY WIRE (DBW) +
2. DRIVE BY WIRE (DBW) -
3. TPS1 SIGNAL
4. SENSOR GROUND
5. TPS2 SIGNAL

6. 5 VOLTS
7. ELECTRONIC CONTROL MODULE (ECM)
8. THROTTLE POSITION SENSOR 2 (TPS2)
9. THROTTLE POSITION SENSOR 1 (TPS1)
10. MOTOR

Figure 33. TPS Circuit

CLICK HERE TO **DOWNLOAD** THE COMPLETE MANUAL

- Thank you very much for reading the preview of the manual.
- You can download the complete manual from: [www.heydownloads.com](http://www.heydownloads.com) by clicking the link below



- Please note: If there is no response to CLICKING the link, please download this PDF first and then click on it.

CLICK HERE TO **DOWNLOAD** THE COMPLETE MANUAL