



# Wacker Neuson Group

Service Manual

**Wheel Loader**

**WL32**



**Vehicle type**

**WL32**

**Date**

**12/2015**

**Document Number**

**1000350669**

**Language**

**[en]**

CLICK HERE TO **DOWNLOAD** THE COMPLETE MANUAL

- Thank you very much for reading the preview of the manual.
- You can download the complete manual from: [www.heydownloads.com](http://www.heydownloads.com) by clicking the link below



- Please note: If there is no response to CLICKING the link, please download this PDF first and then click on it.

CLICK HERE TO **DOWNLOAD** THE COMPLETE MANUAL

## Explanation of symbols and abbreviations

The indication **left** or **right** in the descriptions always refers to the travel direction of the machine.

Symbols	Explanation
•	Identifies a general list
1	Identifies a list in a table (position numbers)
2	
1.	Identifies activities that must be performed in a certain order
2.	
➡	Identifies results
▶	Identifies things to be avoided in the warning and safety instructions
Abbreviations	Explanation
<b>Fig.</b>	Figure
<b>Order no.</b>	Order, item or part number
<b>o/h</b>	Operating hours
<b>BMK</b>	Oil and fuel identifiers
<b>FMI</b>	Failure Mode Identifier
<b>FOPS</b>	Falling Object Protective Structure
<b>(opt)</b>	Option
<b>ROPS</b>	Roll Over Protective Structure
<b>SW</b>	Quickhitch (loader unit)
<b>(WSxx)</b>	Wrench size, for example WS13 = wrench size 13

## E.3 Tightening torques

### General tightening torques

Screw dimensions	Tightening torques in Nm <sup>1</sup>		
	8.8	10.9	12.9
M4	3	4	5
M5	5.5	8	10
M6	10	14	16
M8	23	34	40
M10	46	67	79
M12	79	115	135
M14	125	185	220
M16	195	290	340
M18	280	400	470
M20	395	560	660
M22	540	760	890
M24	680	970	1150
M27	1000	1450	1700
M30	1350	1950	2300

1. These values are valid for screws with untreated, non-lubricated surfaces.

### Specific tightening torques

Designation	Screw dimensions	Tightening torque
Wheel nut	M14 x 1.5	150 Nm
	M18 x 1.5	285 Nm
	M20 x 1.5	400 Nm
High-pressure limiting valve	M8	22 Nm

**Shape H with O-ring and chamber ring**

<b>Dimension</b>	<b>Tightening torque (very lightweight series) in Nm</b>	<b>Tightening torque (lightweight series) in Nm</b>	<b>Tightening torque (heavy series) in Nm</b>
M8 x 1	10	-	-
M10 x 1	20	18	-
M12 x 1.5	-	30	35
M14 x 1.5	-	45	55
M16 x 1.5	-	60	80
M18 x 1.5	-	70	105
M20 x 1.5	-	-	140
M22 x 1.5	-	125	125
M26 x 1.5	-	180	180
M27 x 2	-	180	180
M33 x 2	-	300	380
M42 x 2	-	450	500
M48 x 2	-	600	600
G 1/8 A	20	20	25
G 1/4 A	-	35	45
G 3/8 A	-	70	75
G 1/2 A	-	100	100
G 3/4 A	-	180	180
G 1 A	-	300	300
G 1-1/4 A	-	450	450
G 1-1/2 A	-	540	540

## **Safety instructions for work on traveling drive and axles**

- Keep the loader unit as low as possible when jacking up the machine in order to keep the center of gravity as close to the ground as possible.
- Only use suitable equipment, for example a workshop jack, to jack up and support the machine.

## **Safety instructions for work on the braking system**

- Repair work on the brakes may only be performed by personnel trained for working on braking systems! When in doubt, the work must be performed by manufacturer service personnel!
- Only perform repair work on the braking system if the machine is secured (see Operator's Manual).
- Be careful when handling brake fluid.

## **Safety instructions for work on the frame**

### **Welding work**

- Welding work may only be performed by persons who are trained for this task!
- Welding work on receptacles which contain or contained substances that are flammable, combustible, explosive, or can produce harmful vapors, gasses, mist or dust during welding work may only be performed by persons designated for such work and supervised by a competent person. If you have any problems or questions, be sure to contact the manufacturer's service personnel!
- Park the machine on level and firm ground and prevent it from rolling away.
- Stop the engine, operate and remove the battery master switch.
- If welding work is to be performed at the bottom of the machine, lift the machine with suitable lifting gear and support it safely.
- Disconnect the battery before performing welding work (see Operator's Manual, "Removing the battery").
- Disconnect the plug-and-socket connections on the diesel engine control unit.
- Disconnect plug-and-socket connection on chassis control unit.
- Protect bare clamps and connections from short circuits!
- Attach the welding current terminal directly next to the weld! Only the chassis and the frame are suitable as ground connections. The ground connection on the machine must be free from paint, grease and oil. The following components must not be used as ground connections:
  - Diesel engine, variable displacement motor
  - Radiator
  - Variable displacement pump, hydraulic pump
  - Steering orbitrol
  - Valves
  - Hydraulic cylinders, lines and hoses
  - Axles
  - Pin
  - Bearing
  - Exhaust System
  - Ground cable, cables in general

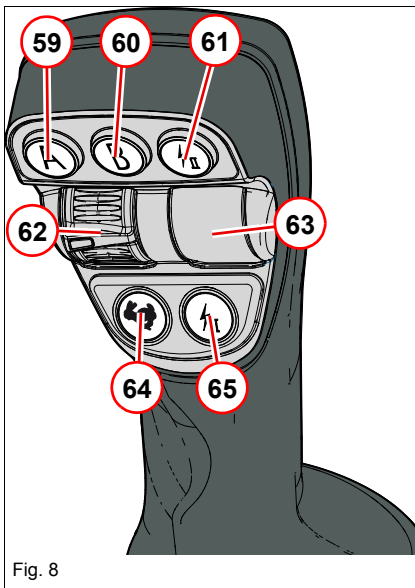
**Loader unit control lever**
**Front view**

**Control elements**

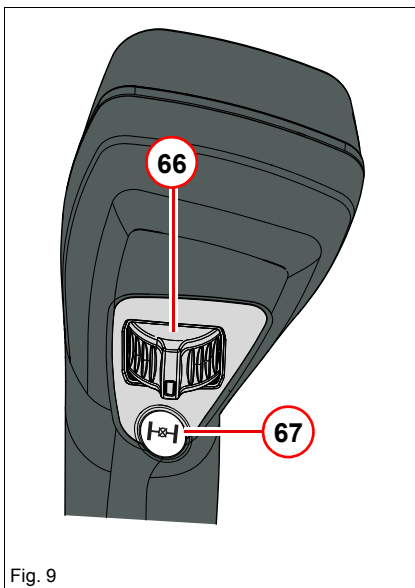
59	Button A
60	Button B
61	Button for front electrical connection II
62	Forward/reverse wheel
63	Not assigned Scroll wheel for 4th control circuit (option)
64	High speed/creep gear button
65	Button for front electrical connection I

**Rear view**

**Control elements**

66	3rd control circuit scroll wheel
67	Differential lock button

# 1 Maintenance

## 1.1 Information on maintenance

### Responsibilities and prerequisites

- The maintenance and inspection personnel must have specialized knowledge about the maintenance and inspection work on the machine.
  - ➔ The necessary expertise can be obtained at training sessions from Wacker Neuson Service.
- Perform maintenance and inspection work only with suitable protective equipment.
  - Wear ear protectors in case of high noise levels.

### Safety instructions

#### Information on maintenance

- Only perform maintenance and inspection work after having read and understood the Operator's Manual.
- Pay attention to the basic safety instructions and to all the warning labels affixed on the machine.
- The Operator's Manual describes the work to be performed.
  - However, the descriptions of the work processes provide the required information only to experienced personnel having appropriate knowledge.
- Always store the Operator's Manual in the place provided for it on the machine.

#### Information on the machine and the attachment

- Only perform maintenance and inspection work if the machine is secured.
- A raised loader unit can fall suddenly and cause serious injury.
- A raised loader unit must be secured with a suitable support if it is absolutely necessary to work underneath it.
- Lower attachments on the ground ensuring that no movements can occur when releasing mechanical or hydraulic connections.
- Secure equipment or components that are to be attached or removed, or whose installation position is to be changed, with the aid of suitable lifting gear or with mounting or support devices to prevent unintentional movement, slipping or falling.
- Remove dirt from steps and handholds to keep them safe and ready for use.



<b>Work to be performed</b>	<b>Operating hours: 250, 750, 1000, 1250, 1750, 2000, 2250, 2750, 3000, etc.</b>	<b>Operating hours: 1500, 2500, 3500, 4500, etc.</b>	<b>Once a month</b>	<b>Once a year</b>
Check the gearbox, engine and hydraulic system for leaks	•	•	•	•
Check the engine, the hydraulic and water radiators for dirt	•	•	•	•
Check the coolant level and antifreeze	•	•	•	•
Check the tension and condition of the V-belt	•	•	•	•
Check the routing of the hoses and pipes		•		•
Check the piston rods of the hydraulic cylinders		•		•
Check the air filter hose	•	•	•	•
Examine the intake muffler for damage or exceptional wear		•		
Check the routing of Bowden cables and electric cables		•		•
Retighten all bolts; pay particular attention to the engine mountings, axle mountings and cardan shaft		•		•
Check the acid level of the battery	•	•	•	•
Clean the battery terminals and check the acid density		•		•
Check the instruments, indicator lights and acoustic warning devices	•	•	•	•
Check the electrical system	•	•	•	•
Check the service brake and parking brake, adjust them if necessary	•	•	•	•
Check the hydraulic steering	•	•	•	•
Check the light system (if equipped)	•	•	•	•
Check the exhaust system		•		•
Check the pivot pins and joint bushes		•		•
Check the center pivot bolts and bearings		•		•
Check the pressure limiting valves of the hydraulic system		•		•
Check the idling speed	•	•	•	•
Check the speed under load and without load		•		•
Check the starter and alternator (see engine manual)		•		•
Check the glow plugs and injectors (see engine manual)		•		•
Check valve clearance. Adjust if necessary (see engine manual)		•		
Check the injection nozzles (every 3000 operating hours, see engine manual)				
Check the engine cover lock for correct function, adjust it if necessary	•	•	•	•
Check the protective ROPS/FOPS structure		•		•
Check the tire condition and tire pressure	•	•	•	•
Change the engine oil and engine oil filter (every 500 operating hours)				•

## Information on cleaning

---

### **Information**

Clean a new machine only with a sponge (for the first three months). As the bottom layers of the paintwork are not fully hardened yet, the paintwork can be damaged if cleaned with a high-pressure cleaner.

Observe the following when cleaning the machine with a high-pressure cleaner:

- ▶ Max. water pressure 130 bar.
- ▶ Max. water temperature 80 °C

In order to avoid damage to labels and other sensitive parts, do not hold the nozzle of the high-pressure cleaner too close to the machine.

---

## General safety check

Check the following points:

- Check all steel parts for damage and loose threaded fittings, in particular the protective ROPS/FOPS structure.
- Check the condition of the seat belt.
- Check the quickhitch for the attachments.
- Check whether all pivot pins are in their correct positions and secured with their locks.
- Check the climbing aids and handholds for correct position.
- Check the cabin windows for damage, cracks and stone impacts.
- Check the condition of the lights and working lights.
- Check the tires for damage and penetration of sharp-edged objects.
- Check the condition of all warning and information labels.

## Fuel system

---

 **WARNING****Injury hazard due to pressure!**

Fuel escaping under high pressure can cause injury to the skin and eyes.

The fuel lines between the fuel feed pump and the cylinder head are high-pressure fuel lines. There is a very high pressure in the high-pressure fuel lines at all times – even if the engine is stopped.

- ▶ Do not open the high-pressure fuel lines.

---

 **Information**

The fuel flows out of the tank and through a fuel filter with a water separator, and is pumped to the injection system by an electric feed pump. The filters and the feed pump are located in the engine compartment. They are accessed by opening the engine cover.

## Refueling with diesel fuel

---

 **CAUTION****Health hazard due to diesel fuel!**

Diesel fuel and fuel vapors are harmful to health!

- ▶ Avoid contact with the skin, eyes and mouth.
- ▶ Seek medical attention immediately in case of accidents with diesel fuel.

---

 **CAUTION****Fire hazard due to diesel fuel!**

Diesel fuel gives off flammable vapors.

- ▶ Do not smoke, avoid fire and open flames.
  - ▶ Never use fuel additives! Additives severely reduce the lubricity of the diesel fuel.
-

## Checking the antifreeze mixture

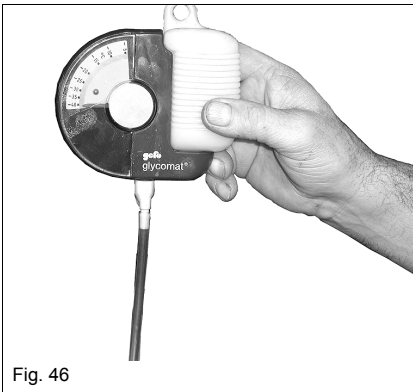

Fig. 46

The antifreeze prevents the coolant from freezing at temperatures below the freezing point and protects the engine block and radiator against internal corrosion. Under normal conditions, an antifreeze concentration of  $-20\text{ }^{\circ}\text{C}$  ( $-4\text{ }^{\circ}\text{F}$ ) to  $-30\text{ }^{\circ}\text{C}$  ( $-22\text{ }^{\circ}\text{F}$ ) is sufficient. The antifreeze concentration can be checked with an antifreeze tester.

## Cleaning the cooling system

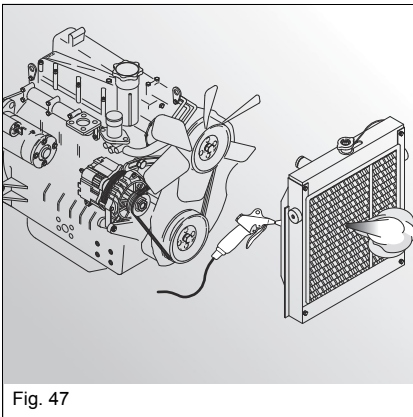

Fig. 47

### **NOTICE**

Risk of technical damage

- ▶ The higher the airborne dust load is, the more often do all radiators have to be checked and cleaned.
- ▶ Always cover up the intake connection of the air filter before cleaning.
- ▶ Do not damage the radiator fins when cleaning the radiator.
- ▶ Carefully straighten bent radiator fins.



### **Environment**

Risk of damage to the environment

- ▶ Only clean the machine in a suitable place where the waste water can be collected in an environmentally friendly manner.
- ▶ Collect contaminated waste water and dispose of it in an environmentally friendly manner.

Clean dirty radiators with compressed air. Very dirty radiators can also be cleaned with water and high pressure.

- Clean the engine radiator.
- Clean the hydraulic oil radiator.
- Clean the alternator only with compressed air.

## Adding hydraulic oil

### NOTICE

Risk of technical damage.

- ▶ Use the correct oil type, see chapter *Fluids and lubricants on page 1-15*.
- ▶ Carefully open the hydraulic oil filler neck to release the pressure in the hydraulic oil reservoir.

Add hydraulic oil if the hydraulic oil level is below the “Max” mark.

1. Unscrew the breather filter.
  - ➔ The residual pressure in the hydraulic oil reservoir is released.
2. Add hydraulic oil.
3. Check the hydraulic oil level.
  - ➔ The hydraulic oil level must be between the “Min” and “Max” marks.
4. Screw in the breather filter.

## Changing hydraulic oil

### NOTICE

Risk of technical damage.

- ▶ Use the correct oil type, see chapter *Fluids and lubricants on page 1-15*.
- ▶ Carefully open the hydraulic oil filler neck to release the pressure in the hydraulic oil reservoir.



### Environment

Use a suitable container to collect the hydraulic oil as it drains and dispose of it in an environmentally friendly manner!

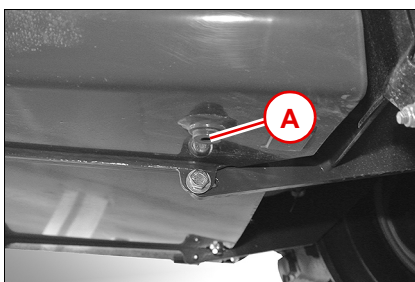

Fig. 59

1. Unscrew the breather filter.
  - ➔ The residual pressure in the hydraulic oil reservoir is released.
2. Position a suitable container with sufficient volume underneath the hydraulic oil reservoir – see *“Fluids and lubricants” on page 1-15*.
3. Open drain plug **A**.
4. Drain the hydraulic oil completely.
5. Close drain plug **A**.
6. Add new hydraulic oil – see *“Adding hydraulic oil” on page 1-51*.

## Replacing the hydraulic oil filter element



### Environment

Use a suitable container to collect the hydraulic oil as it drains and dispose of it in an environmentally friendly manner!

## 1.17 Axles/traveling drive

### Checking and replacing the axle oil

#### Preparations

1. Park the machine on firm, level and dry ground.
2. Apply the parking brake.
3. Lower the loader unit to the ground.
4. Stop the engine.

#### Checking the axle oil level

1. Position the machine so that the wheel check plugs c are centered.
2. Unscrew check plugs a, b and c.
  - The gearbox oil must be up to the bottom edge of the filler opening.
3. Add gearbox oil through the inspection holes if necessary.
4. Screw check plugs a, b and c back in.

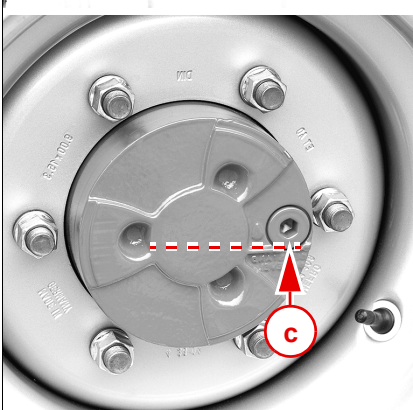
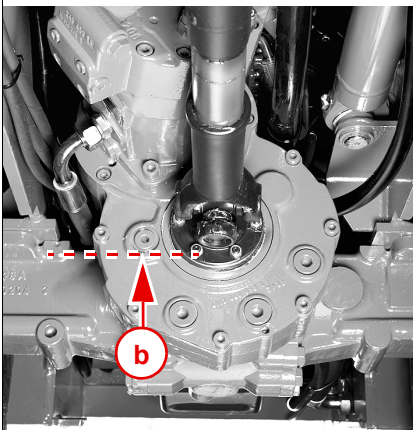
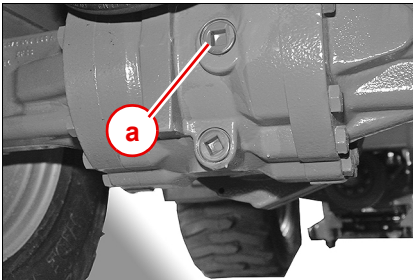

Fig. 69

## Regeneration of diesel particulate filter

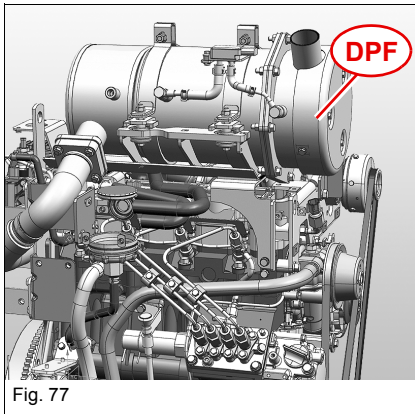

Fig. 77

### Description

The soot resulting from the combustion of the diesel fuel is collected and burned in the diesel particulate filter DPF at regular intervals. The exhaust gas reaches a temperature of up to 600 °C (1,112 °F) at the exhaust outlet during this process. This process is called regeneration.

The soot load is the contamination level in the diesel particulate filter. Among other things, this contamination level depends on the load on the diesel engine:

- High engine load = less deposits.
- Low engine load = more deposits.

### NOTICE

If the soot load of the diesel particulate filter reaches a critical value, the diesel particulate filter/engine can be damaged. Engine output is reduced if the soot load reaches a critical value.

- ▶ If engine output is reduced, immediately start and end manual regeneration in a safe environment – see [“Interrupting automatic regeneration manually” on page 1-73](#).

### Indicator lights

Three indicator lights indicate the regeneration status:

**62:** diesel particulate filter regeneration required.

- The indicator light illuminates if regenerating the diesel particulate filter is necessary.
  - Regeneration can be started manually.
  - Regeneration is automatically started.

**63:** interrupt diesel particulate filter regeneration.

- This indicator light illuminates if regeneration is interrupted.
  - Regeneration can be started manually.

**64:** high exhaust-gas temperature.

- This indicator light illuminates during regeneration. It goes out once regeneration is over and the exhaust system has cooled down.

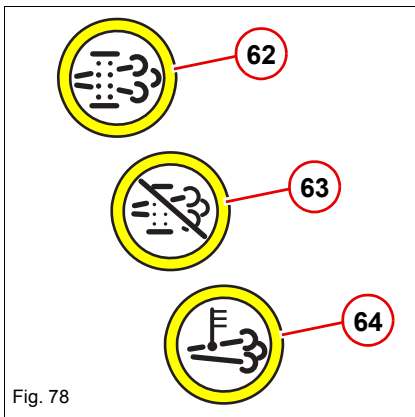

Fig. 78

## Removing/installing the engine

### Preparing work

Tools:

- Suitable lifting gear  
Load-bearing capacity min. 250 kg
- Suitable slings (cables and shackles) with corresponding load-bearing capacity
- Container for collecting oil
- Receptacle for collecting the coolant
- Plugs (different sizes) for closing the oil lines

### Technical data

BMK	Designation	Weight
	Engine	194 kg



### Environment

Use a suitable container to collect the fuel and coolant as they drain and dispose of them in an environmentally friendly manner!

### Removal



### WARNING

#### Contact with hot liquids and machine components

Death or serious injury due to skin burns.

- ▶ Wear suitable protective clothing.
- ▶ Let liquids and the diesel engine cool down.
- ▶ Observe instructions.

1. Remove the engine cover – see [“Removing/installing the engine cover” on page 10-1.](#)
2. Remove the base plate – see [“Removing/installing the base plate” on page 11-16.](#)
3. Drain the coolant. To do this, open drain plug **A** on the lower side of the radiator.
4. When only a small amount of fluid flows out, also open the filler inlet on the coolant reservoir.

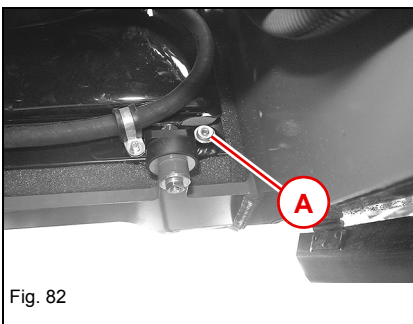

Fig. 82



## 2.6 Removing/installing the fuel tank

### Preparing work

Tools:

- Suitable receptacles for collecting the fuel

### Technical data



	Value	BMK	Remark/designation	
1	5.5 kg		Fuel tank	

For non-specified tightening torques, see chapter "Introduction/tightening torques"



### **Environment**

Use a suitable container to collect the fuel as it drains and dispose of it in an environmentally friendly manner!

## 4 Traveling drive

### 4.1 Traveling drive hose routing

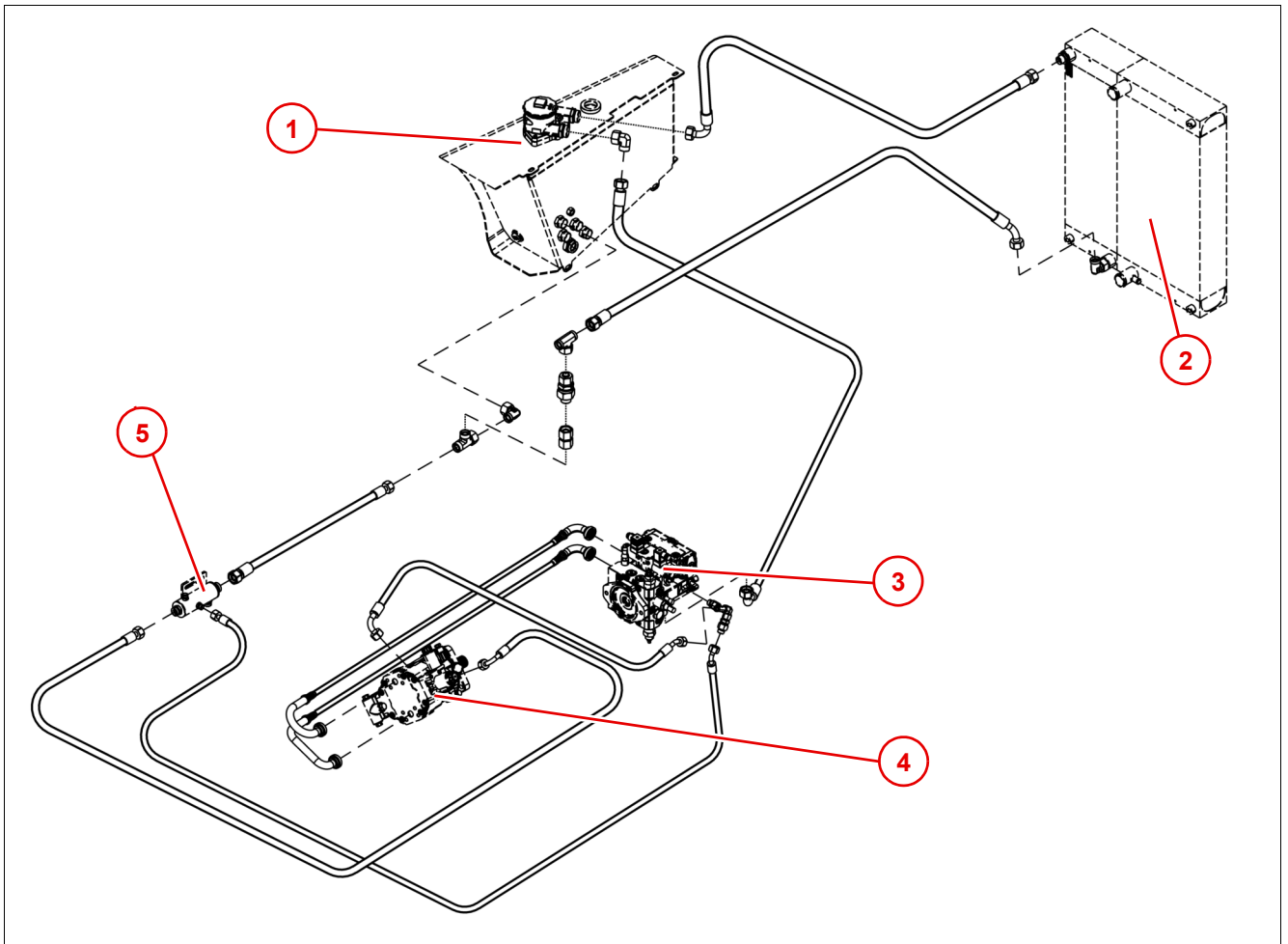

Pos.	Designation
1	Hydraulic oil reservoir
2	Hydraulic oil radiator
3	Variable displacement pump
4	Variable displacement motor
5	Manifold

CLICK HERE TO **DOWNLOAD** THE COMPLETE MANUAL

- Thank you very much for reading the preview of the manual.
- You can download the complete manual from: [www.heydownloads.com](http://www.heydownloads.com) by clicking the link below



- Please note: If there is no response to CLICKING the link, please download this PDF first and then click on it.

CLICK HERE TO **DOWNLOAD** THE COMPLETE MANUAL

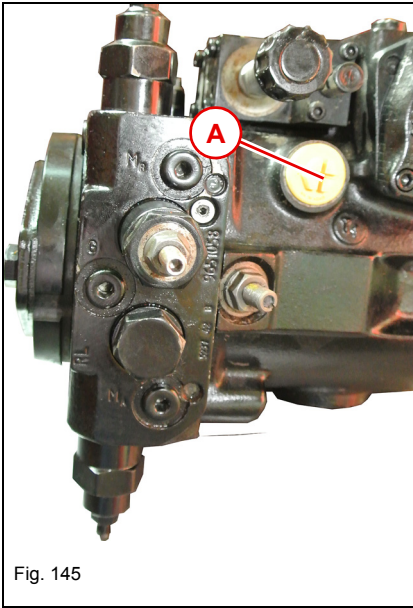

### Installation

1. Set the variable displacement pump down as pictured.
2. Remove plug **A**.
3. Fill the variable displacement pump approximately half full of hydraulic fluid – see *“Fluids and lubricants” on page 1-15.*
4. Install the threaded fitting on connection **A** and close it with a cap.
5. Fasten suitable lifting gear (for example a round sling) onto the variable displacement pump.

### CAUTION

#### Injury hazard due to heavy component.

- ▶ Use lifting gear of sufficient lifting capacity.
- ▶ Use functionally safe lifting gear.
- ▶ Use the lifting gear on firm and level ground.
- ▶ Fasten the lifting gear in a suitable position of the component, or in a position provided for this.

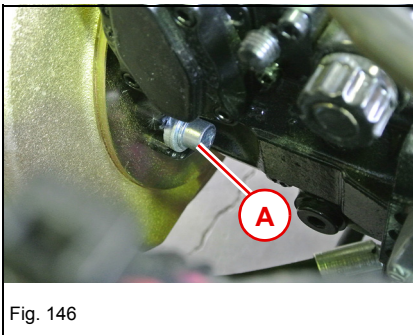

6. Install the variable displacement pump on the clutch bell. To do this, screw in and tighten one screw **A** on each side.

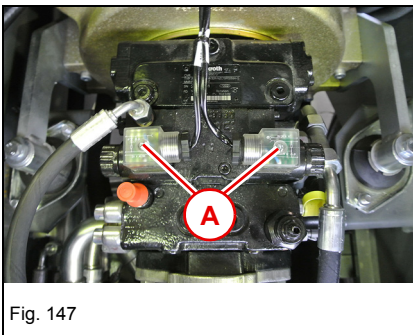

7. Fix hydraulic lines.
8. Install the gear pump – see *“Removing/installing the gear pump” on page 8-8.*
9. Plug on two connectors **A** and affix with screws.
10. Tilt back the control stand.
11. Start the engine and allow to run at low speed.
12. Check the hydraulic oil level – see *“Checking the hydraulic oil level” on page 1-50* and add hydraulic oil if necessary.

### CAUTION

#### Accident hazard due to reduced braking effect

Air can be drawn into the system when the brake circuit is opened.

- ▶ Bleed the brake circuit with brake bleed equipment.

## 4.6 Removing/installing the cardan shaft

### Preparations

1. Park the machine on firm, level and dry ground.
2. Apply the parking brake.
3. Lower the loader unit to the ground.
4. Stop the engine.
5. Block the oscillating articulation (see Operator's Manual).

### Removal

1. Remove all nuts (WS 13) at the front axle joint **A**.
2. Remove the cardan shaft from the front axle by sliding it backward.

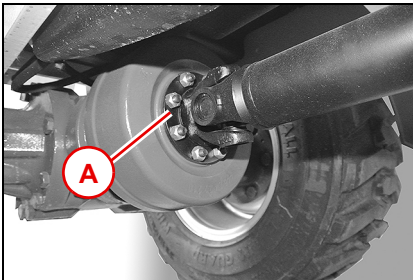

Fig. 163

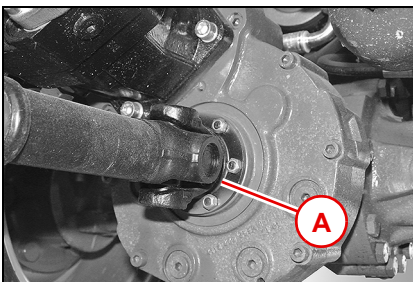

Fig. 164

3. Remove all nuts (WS 13) at the rear axle joint **A**.
4. Remove the cardan shaft from the rear axle by sliding it forward.

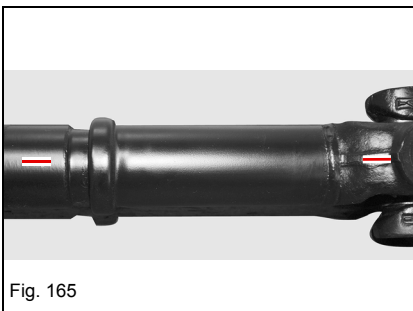

Fig. 165

### Installation

#### CAUTION

#### **Injury hazard due to incorrect installation of the cardan shaft!**

The cardan shaft joints can be damaged if they are not properly aligned. Persons standing in immediate proximity can be severely injured. The machine can be damaged.

- ▶ Align the cardan shaft on the mark.

1. Clean the contact area and the stud bolts on the front axle **A**.
2. Apply locking compound to stud bolts.
3. Slide the cardan shaft onto the stud bolts on the front axle.
4. Screw nuts **B** onto the threaded bolts and tighten them.

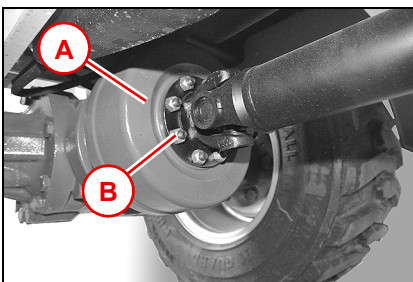
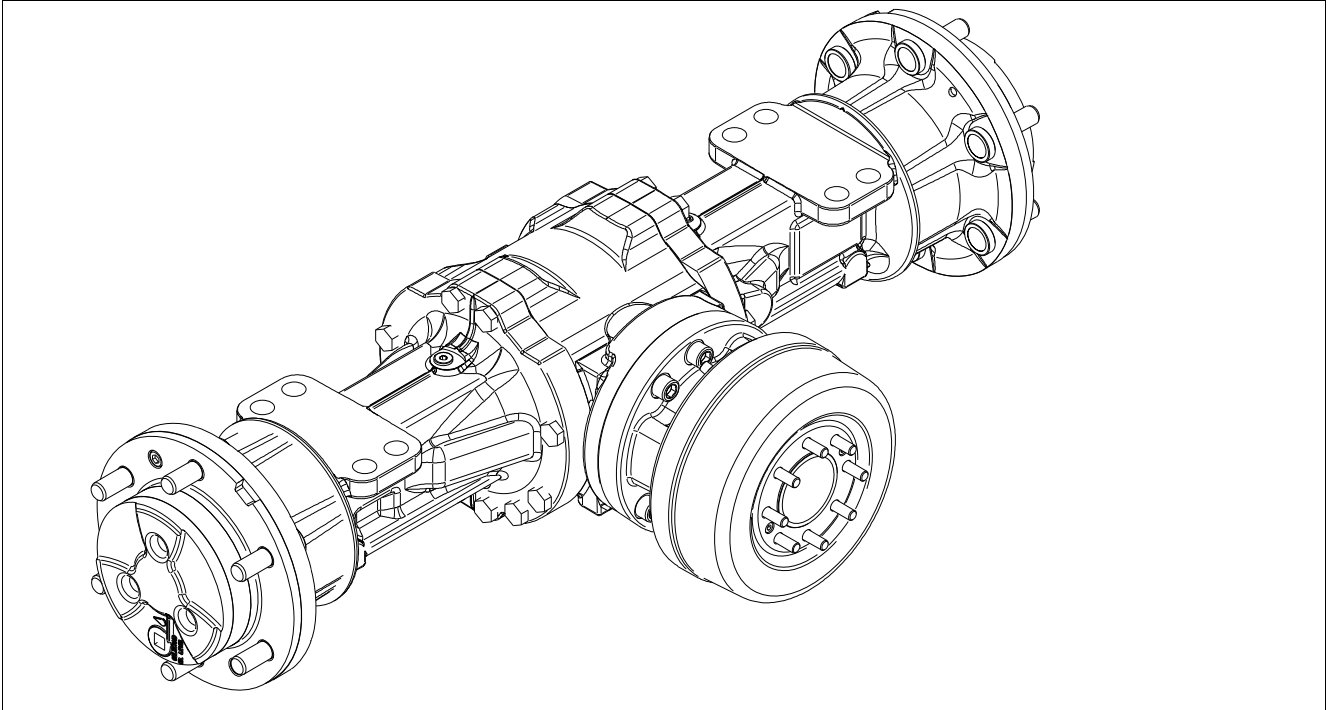

Fig. 166

## 5 Axles

### 5.1 Front axle

#### Overview



	<b>Value</b>	<b>BMK</b>	<b>Remark/designation</b>	
	175 kg		Front axle	
For non-specified tightening torques, see chapter "Introduction/tightening torques"				

## 6 Brake

### 6.1 Removing/installing the brake pedal

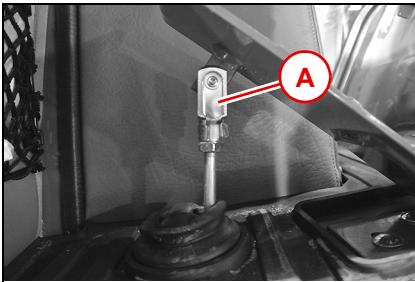

Fig. 189

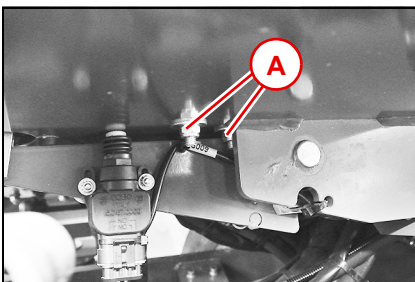

Fig. 190

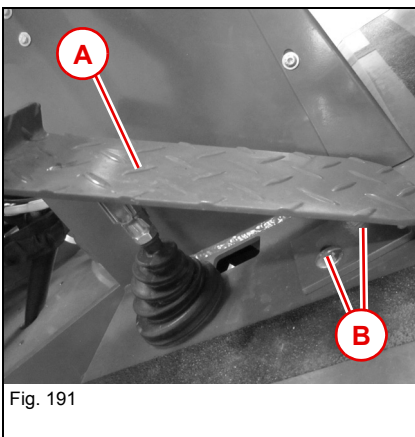

Fig. 191

1. Remove clamp **A**.

2. Tilt the control stand sideways – see [“Raising the control stand sideways” on page 1-17](#).

3. Unscrew nuts **A**.

4. Tilt back the control stand.

5. Pull out screws **B**.

6. Remove brake pedal **A**.

Install in the reverse order.

## Removing/installing the steering orbitrol

### Preparing work

Tools:

- Suitable receptacle for collecting the hydraulic oil
- Plugs (different sizes) for closing the oil lines

### Technical data

BMK	Designation	Weight
S4	Steering orbitrol	6 kg



### Environment

Use a suitable container to collect the hydraulic oil as it drains and dispose of it in an environmentally friendly manner!

### Removal

1. Release the pressure in the hydraulic system – see [“Releasing residual pressure in the hydraulic system” on page E-32.](#)
2. Unscrew cover plate **A**. Remove four screws for this.

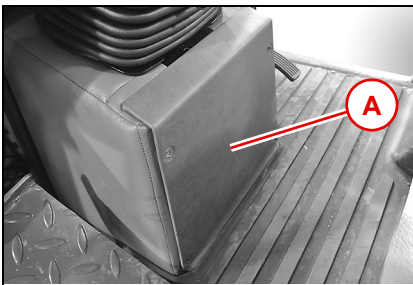

Fig. 202

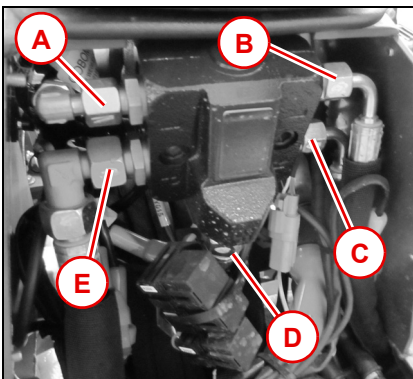

Fig. 203

3. Mark installation positions on all hydraulic lines.
4. Loosen union nut **A** on connection **T** and remove hydraulic hose.
5. Loosen union nut **B** on connection **L** and remove hydraulic hose.
6. Loosen union nut **C** on connection **R** and remove hydraulic hose.
7. Loosen union nut **D** on connection **EF** and remove hydraulic hose.
8. Loosen union nut **E** on connection **P** and remove hydraulic hose.
9. Close all openings with suitable plugs.



### **Checking the emergency steering features**

1. With the engine stopped, turn the steering wheel clockwise or anticlockwise until the articulation is at the limit.
2. If the steering wheel can be steered beyond the limit, replace the steering orbitrol – see *“Removing/installing the steering orbitrol” on page 7-3.*



## Environment

Use a suitable container to collect the hydraulic oil as it drains and dispose of it in an environmentally friendly manner!

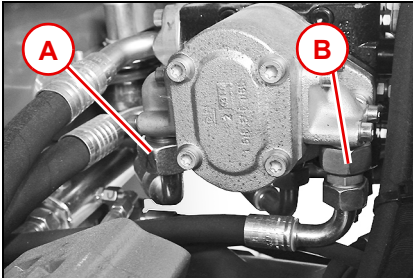

Fig. 233

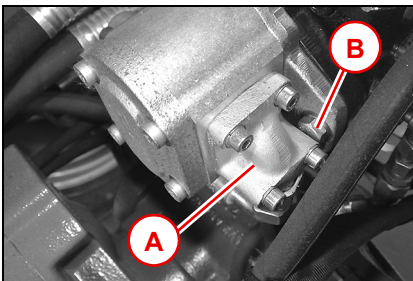

Fig. 234

## Remove

1. Release the pressure in the hydraulic system – see *“Releasing residual pressure in the hydraulic system”* on page E-32.
2. Unscrew union nut **A** and remove hydraulic hose.
3. Unscrew union nut **B** and remove hydraulic hose.
4. Close the openings oil-tight with the plugs.
5. Remove the mounting parts **A** of the pump on both sides. To do this, remove 4 cheese-head screws each.
6. Then screw off the pump. To do this, remove the hexagon head screws **B** and the corresponding spring washers.

Install in the reverse order.

## NOTICE

Pressure loss due to malfunctioning seals.

- ▶ Always use new O-rings when installing the mounting parts.
- ▶ Ensure that the O-rings are not damaged by sharp edges during installation.

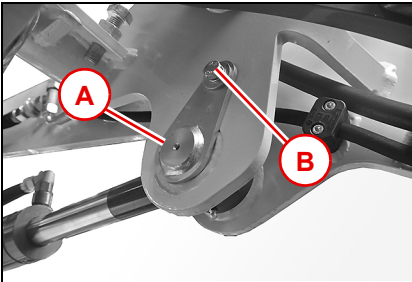

Fig. 253

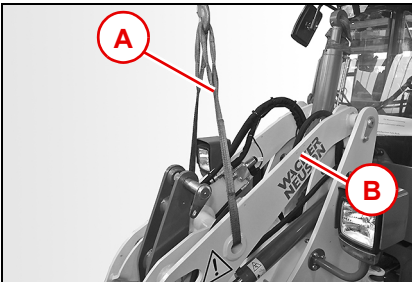

Fig. 254

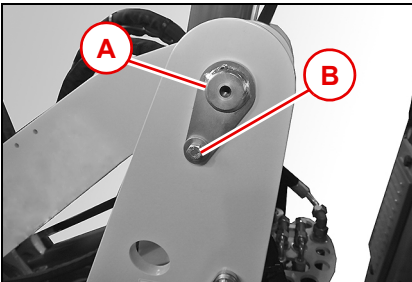

Fig. 255

10. Remove both lift cylinders from the loader unit. Unscrew one screw **B** each for this.

11. Expel one pin **A** each.

12. Place the lift cylinders on the front chassis section.

13. Secure loader unit **B** with suitable lifting gear **A**.

14. Unscrew one screw **B** on each side.

15. Expel one pin **A** each.

16. Lift loader unit with suitable lifting gear.

17. Reverse the machine away carefully.

Install in the reverse order.

### **NOTICE**

Pay attention to the following instructions for assembly:

- ▶ Apply a thin coat of grease to the pins and bearings before inserting the pins.
- ▶ Always use spring washers and washers for tightening the pins.
- ▶ After completing installation, apply grease to the cylinder and loader unit bearings.

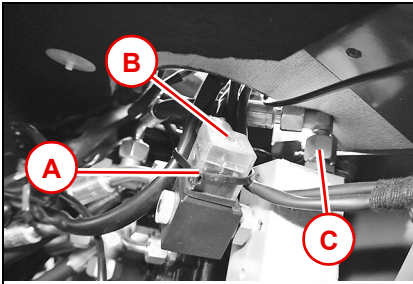

Fig. 267

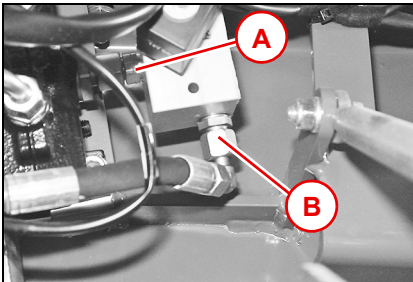
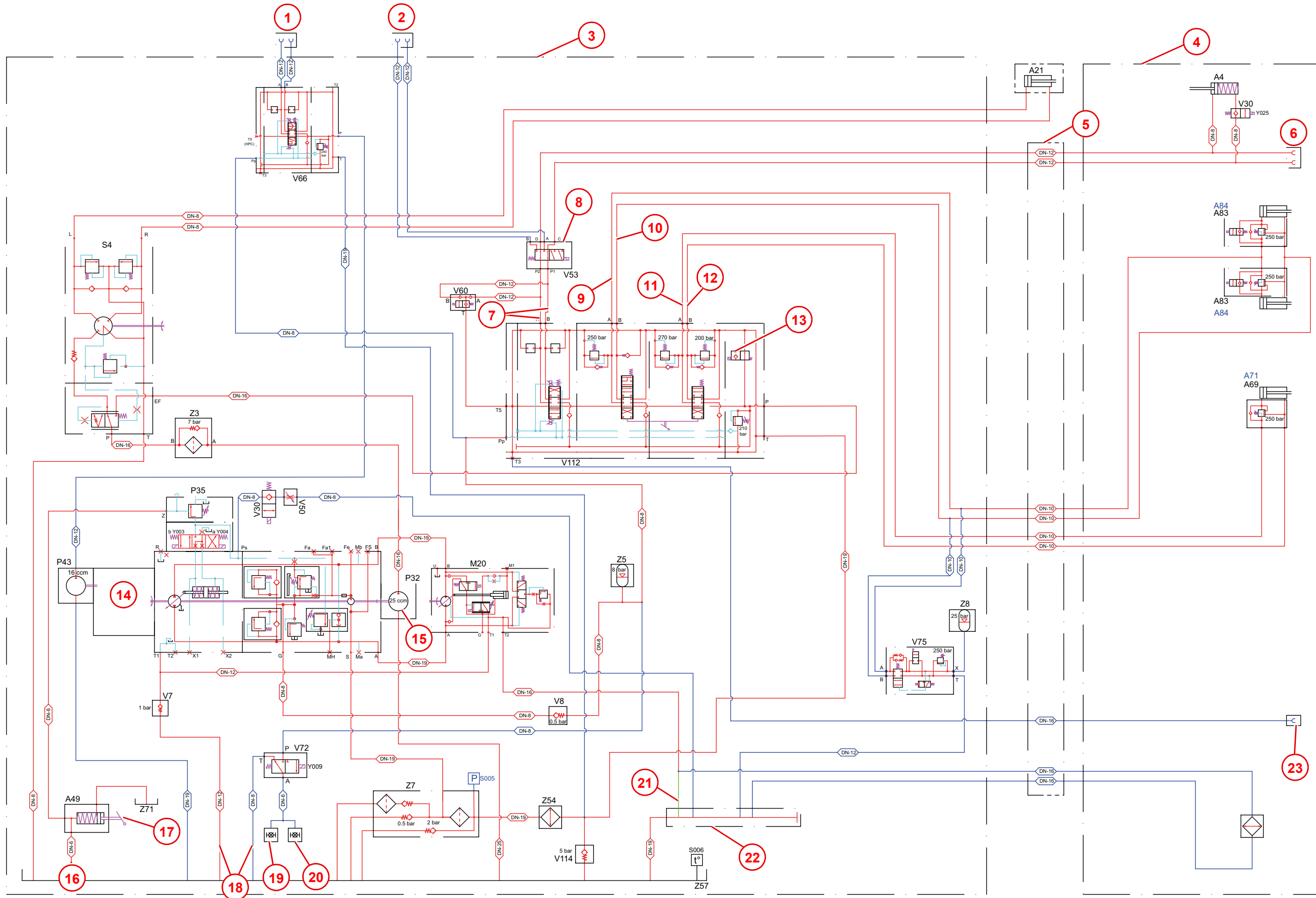

Fig. 268

1. Release the pressure in the hydraulic system – see *“Releasing residual pressure in the hydraulic system” on page E-32.*
2. Tilt the control stand sideways – see *“Raising the control stand sideways” on page 1-17.*
3. Remove cable ties **A**.
4. Loosen screw **B** and pull off the connector.
5. Loosen union nut **C** and remove hydraulic hose.
6. Close the openings oil-tight with the plugs.
7. Unscrew union nuts **A** and **C** and remove hydraulic hoses.
8. Close the openings oil-tight with the plugs.

Install in the reverse order.

8.17 Hydraulics diagram – HDS21/3 with HDS21/1 or 6/2 directional valve



## 9.2 Removing/installing the machine control unit

### Removal

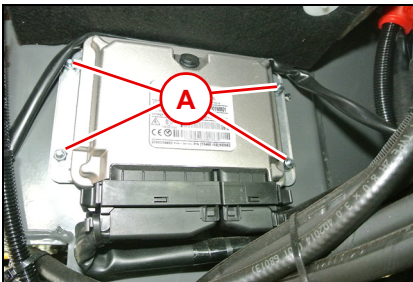

Fig. 274

1. Tilt the control stand sideways – see *“Raising the control stand sideways”* on page 1-17.
2. Remove all connectors.
3. Remove the four nuts **A**.
4. Remove the control unit.

### Installation

#### Information

No software is installed on the machine control unit when it is delivered. This software has to be installed with the Wacker Neuson diagnostic tool WANDA.

Then the machine configuration (serial number, options, characteristic valve curves, etc.) has to be loaded again.

- ▶ Ask Weidemann service (service@weidemann.de) for the configuration file. State the serial number and operating hours of the machine as you do so.
- ▶ Have a PC/notebook ready with WANDA software installed.

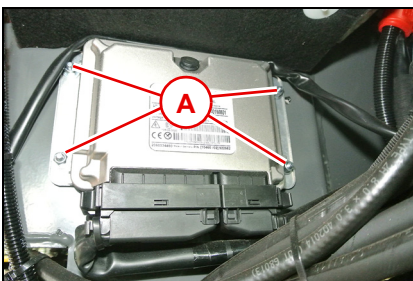

Fig. 275

1. Fasten the control unit with four nuts **A**.
2. Insert all connectors.

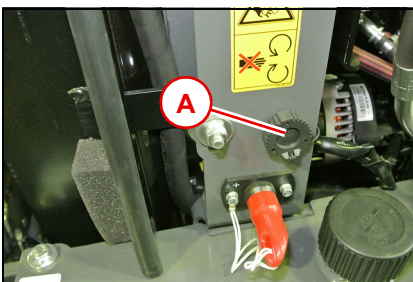
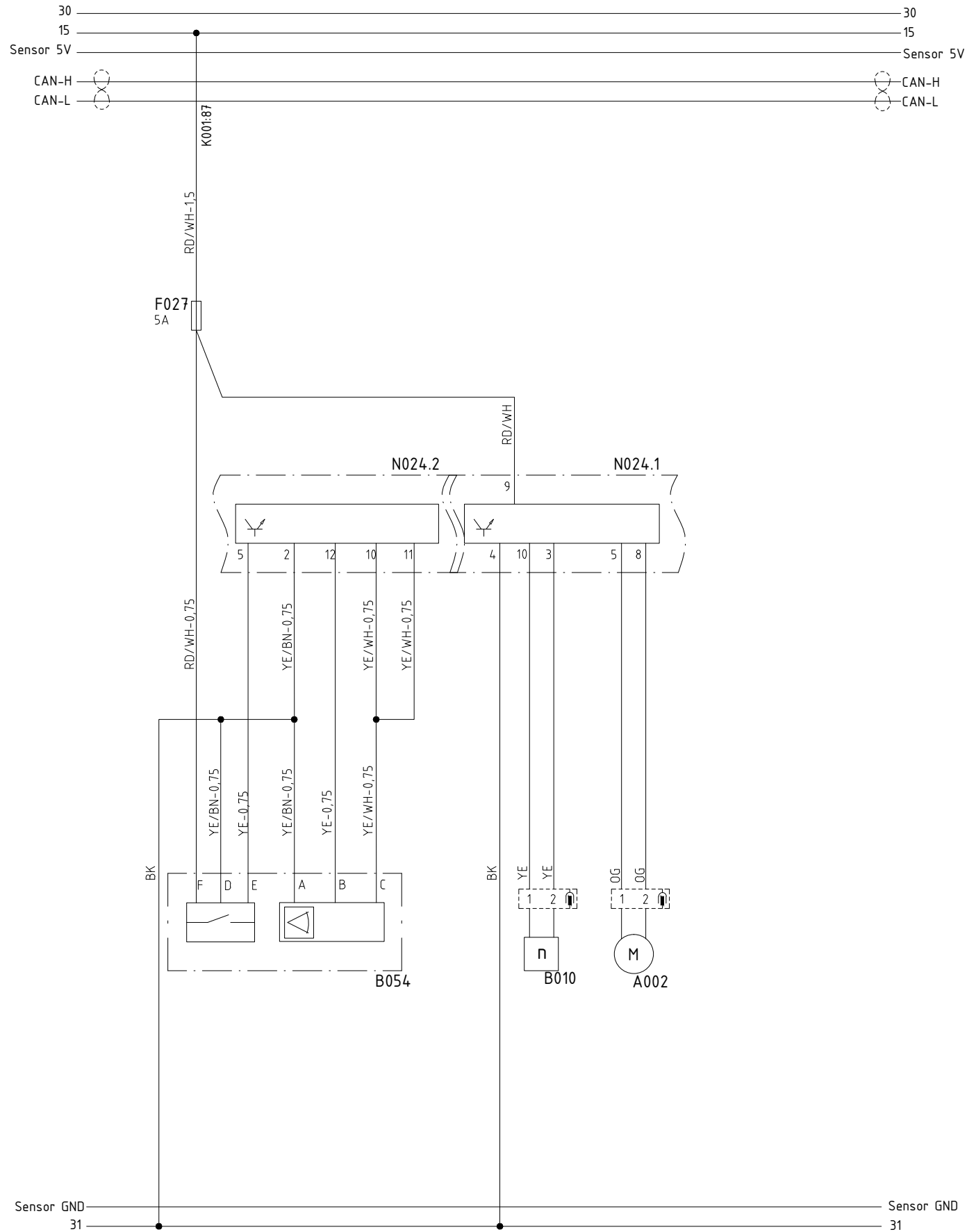

Fig. 276

3. Start the Wacker Neuson update tool and download the update file if necessary – see *“Instructions for initial installation of Wacker Neuson diagnosis tool”*.
4. Connect the USB connector of the CAN-USB interface with the USB connection of the PC/notebook.
5. Remove cap **A** and connect the interface with the machine.
6. Tilt back the control stand – see *“Raising the control stand sideways”* on page 1-17.
7. Engage the starter of the machine.
8. Start WANDA – see *“WANDA Operator’s Manual”*.

**9.8 Electrical diagram – Perkins engine 404D-22**



Assignment	Designation
A002	Engine speed regulation
B010	Diesel engine speed
B054	Accelerator pedal
F027	Engine control unit, accelerator pedal, DPF (diesel particulate filter)
N024	Engine speed control

**9.18 Electrical diagram – working lights; rotating beacon**

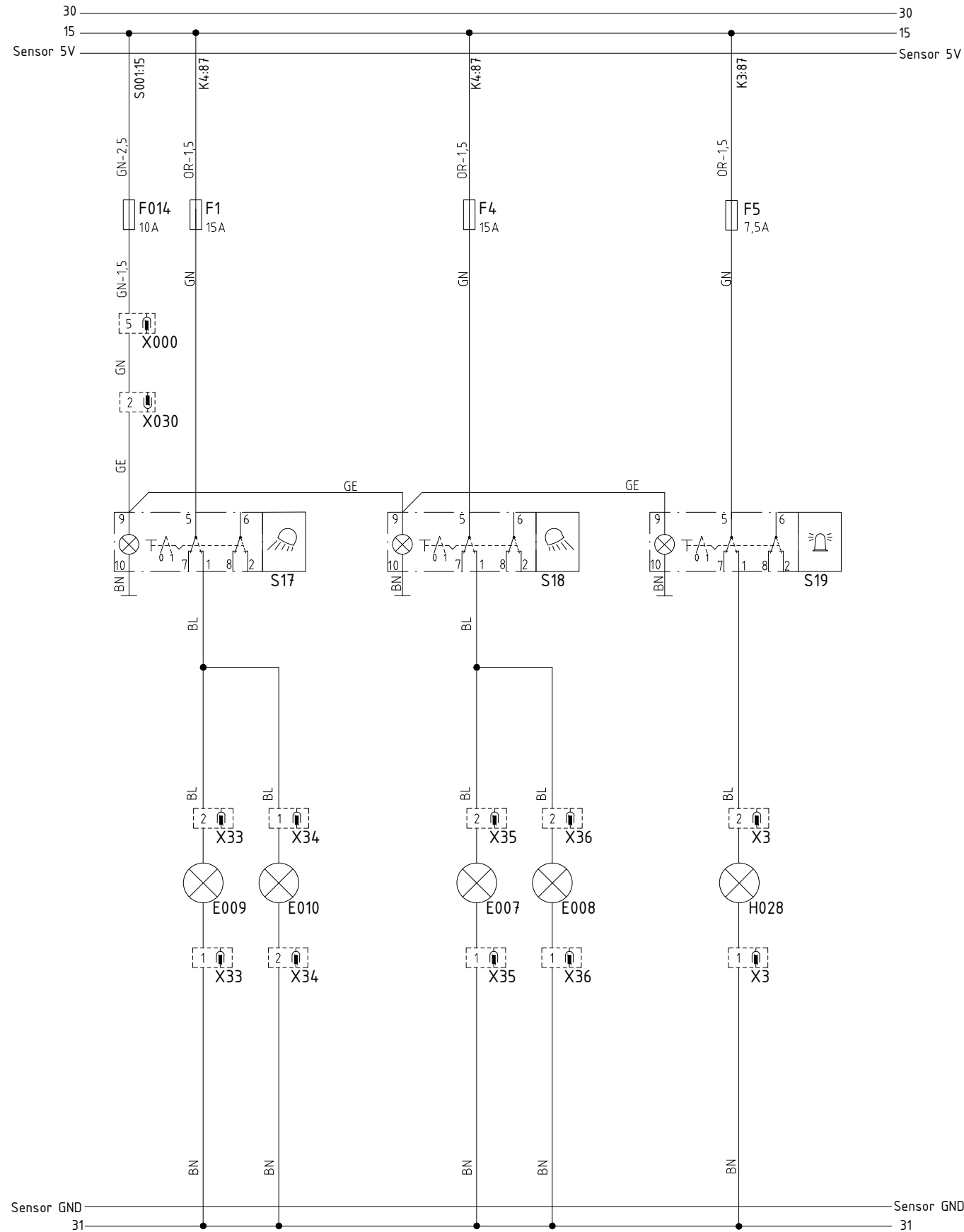

Assignment	Designation
E007	Rear working light
E008	Rear working light
E009	Front working light
E010	Front working light
F001	Front working light
F004	Rear working light
F005	Rotating beacon, radio
F014	Cabin
H028	Rotating beacon
S017	Front working light
S018	Rear working light
S019	Rotating beacon
X...	General connector



<b>BMK</b>	<b>Designation</b>
K088	Fuel pump switching relay
K089	DPF pump switching relay
K090	DPF glow plug switching relay
K112	Manual inching switching relay
<b>M</b>	<b>Drives (electrical system)</b>
M001	Starter
M004	Fan
M009	Fuel pump
M010	Air-suspension seat
M013	Fan
<b>N</b>	<b>Electronics (electrical system)</b>
N003	Preheating time control unit
N004	Drive electronics
N005	Diesel engine electronics
N024	Engine speed control
<b>P</b>	<b>Instruments (electrical system)</b>
P002	Fuel level indication
P003	Diesel engine coolant temperature indicator
P007	Tachometer
<b>R</b>	<b>Resistors (electrical system)</b>
R001	Glow plug
R017	Bus terminating resistance
R018	Bus terminating resistance
R032	Heated seat
<b>S</b>	<b>Switches (electrical system)</b>
S001	Preheating start switch
S002	Engine oil pressure switch
S005	Hydraulic oil pressure switch
S006	Hydraulic oil temperature switch
S008	Battery master switch
S009	Brake light switch
S011	Parking brake switch
S012	Steering-column control lever (left)
S015	Heating switch



**CAUTION**

**Injury hazard due to heavy component**

After removing the fastening screws of trailer coupling **B**, frame cover **A** is no longer firmly fastened to the counterweight.

- ▶ When the trailer coupling is removed, press against the frame cover so it does not fall down.
- 

3. Remove four screws with nuts.
4. Remove the trailer coupling.
5. Remove the chassis cover.

Install in the reverse order.

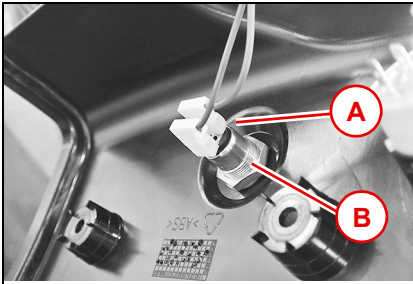

Fig. 314

9. Disconnect connector **A**.
10. Remove nut **B**.
11. Remove the connector.

Install in the reverse order.

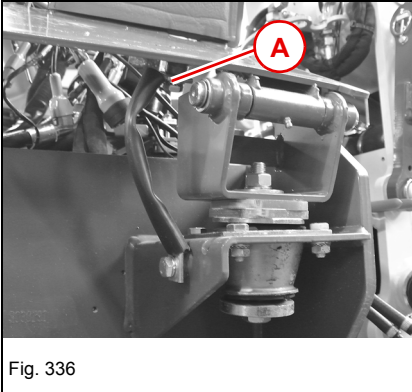

Fig. 336

9. Remove ground connection **A**.

**! DANGER**

**Raising heavy components.**

Death or serious injury.

- ▶ Use lifting gear of sufficient lifting capacity.
- ▶ Use functionally safe lifting gear.
- ▶ Use the lifting gear on firm and level ground.
- ▶ Fasten the lifting gear in a suitable position of the component, or in a position provided for this.
- ▶ Only use slings of sufficient dimensions and in a perfect condition.
- ▶ Protect slings against sharp corners and edges, for example with protectors.

10. Fasten suitable lifting gear at the lifting points of the base plate in order to lift the tilted base plate.

11. Tighten the lifting gear with a crane until the load on the base plate is released.

12. Remove gas strut **A**.

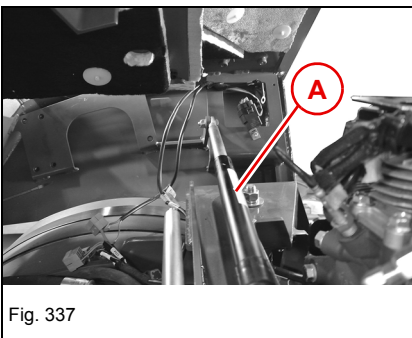

Fig. 337

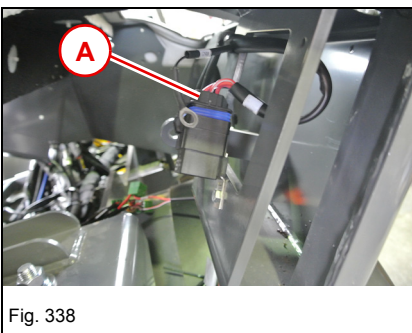

Fig. 338

13. Pull off connector K038 (switching relay option) **A**.



Error code			
SPN (component)		FMI (error type)	
SPN	SPN text	FMI	FMI text
517918	Identification error	12	Internal control unit error
518905	OMD load indicator <--> ECU error	9	Timeout while receiving CAN message
518905	OMD load indicator <--> ECU error	19	Data reception with active error status
518905	OMD load indicator <--> ECU error	24	Difference between CAN message and pin signal
518960	Parking brake switch S011	26	Channel "NO" not in valid range
518960	Parking brake switch S011	24	Difference between channels
518970	Creep gear push button S021	3	Short circuit to battery
518970	Creep gear push button S021	4	Actuated too long or short circuit to ground longer than 10 seconds
518970	Creep gear push button S021	26	Value not in valid range
518974	Differential lock push button S025	3	Short circuit to battery
518974	Differential lock push button S025	4	Actuated too long or short circuit to ground longer than 60 seconds. [Only while button is pressed – error resets automatically]
518974	Differential lock push button S025	26	Value not in valid range
519015	Neutral switch S066	4	Short circuit to ground
519015	Neutral switch S066	28	Open wiring or short circuit to Bat+
519015	Neutral switch S066	26	Value not in valid range
519033	Switch VLS OFF S084	24	Logic error between redundant signals
519050	Hydro comfort switch S101	3	Short circuit to Bat+
519050	Hydro comfort switch S101	26	Value not in valid range
519053	Operator presence switch S104	24	Difference between channels
519058	Switch electric function 1 S109	4	Short circuit to ground
519058	Switch electric function 1 S109	26	Value not in valid range
519058	Switch electric function 1 S109	28	Open wiring or short circuit to Bat+
519059	Switch electric function 2 S110	4	Short circuit to ground
519059	Switch electric function 2 S110	26	Value not in valid range
519059	Switch electric function 2 S110	28	Open wiring or short circuit to Bat+
519060	Road-travel lock switch S111	24	Difference between channels
519065	Limit switch 1 S116 / limit switch 2 S142	24	Logic error between both switches
519066	Joystick push button 2 S117	3	Short circuit to Bat+
519066	Joystick push button 2 S117	4	Actuated too long or short circuit to ground longer than 60 seconds
519066	Joystick push button 2 S117	26	Value not in valid range
519090	VLS mode switch S141	24	Logic error between redundant signals
519090	VLS mode switch S141	26	Channel "NC" not in valid range
519107	Pilot control pressure switch raise/lower S162/S163	24	Logic error between raise and lower

CLICK HERE TO **DOWNLOAD** THE COMPLETE MANUAL

- Thank you very much for reading the preview of the manual.
- You can download the complete manual from: [www.heydownloads.com](http://www.heydownloads.com) by clicking the link below



- Please note: If there is no response to CLICKING the link, please download this PDF first and then click on it.

CLICK HERE TO **DOWNLOAD** THE COMPLETE MANUAL