

Service manual

Mobile excavator

EW100



Vehicle model	E06-06
Edition	1.4
Language	en
Article number	1000324385
From serial number	WNCE0606TPAL00200



**WACKER
NEUSON**

CLICK HERE TO **DOWNLOAD** THE COMPLETE MANUAL

- Thank you very much for reading the preview of the manual.
- You can download the complete manual from: www.heydownloads.com by clicking the link below



- Please note: If there is no response to CLICKING the link, please download this PDF first and then click on it.

CLICK HERE TO **DOWNLOAD** THE COMPLETE MANUAL

Operation

1.6 Machine overview

Position	Designation
1	Lights
2	Working lights
3	Handhold
4	Front stabilizer legs (option)
5	Auxiliary hydraulics
6	Lifting eye/tie-down point
7	Door arrester
8	Door handle and lock
9	Rotating beacon
10	Rear working light
11	Hydraulic oil filler inlet
12	Exhaust pipe
13	Counterweight
14	Reservoir filler inlet
15	Rear lights
16	Stabilizer blade
17	Transport bar for clamshell bucket
18	Maintenance door
19	Tool kit
20	Rocker cover
21	Engine cover

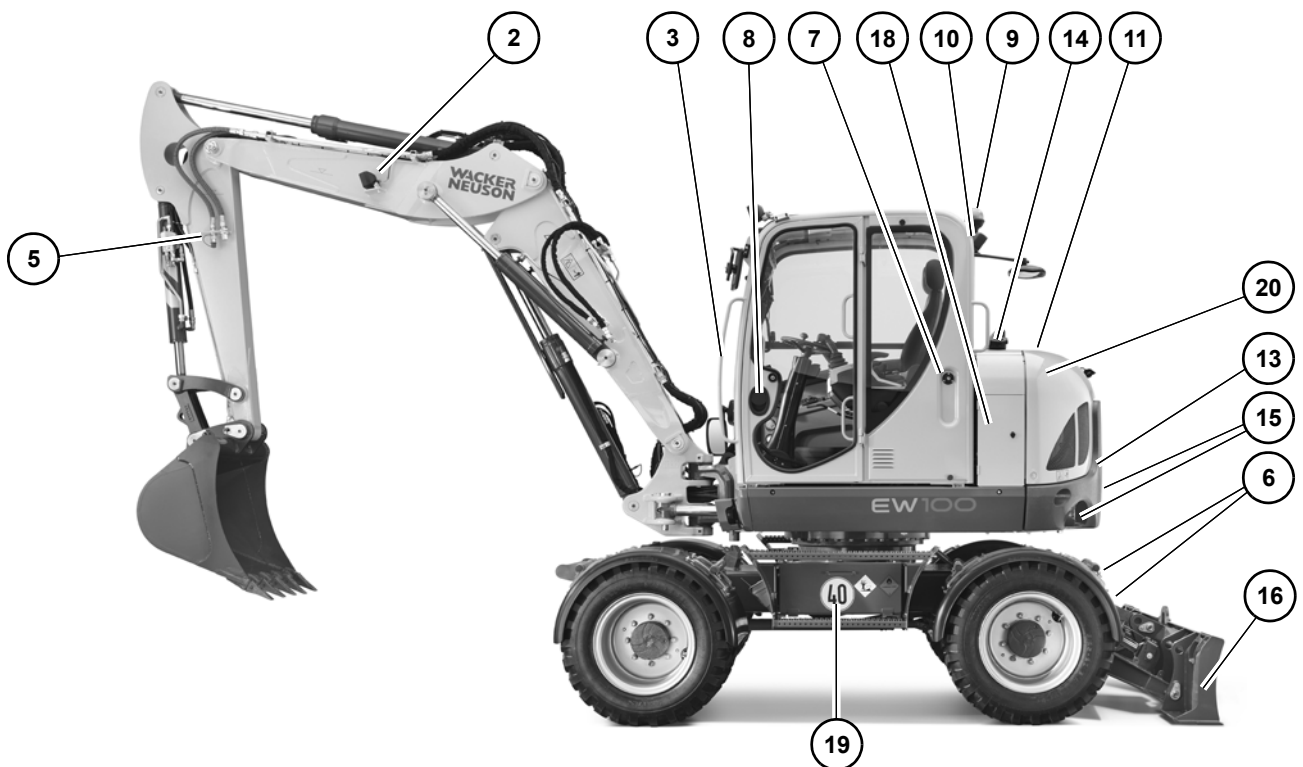
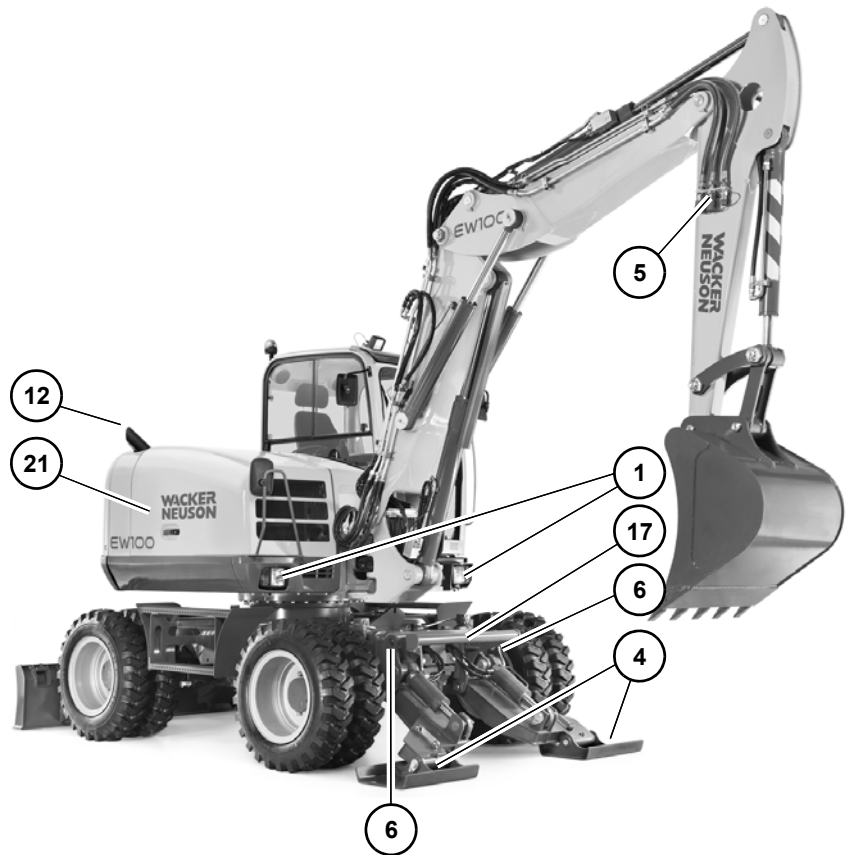

Fig. 14:

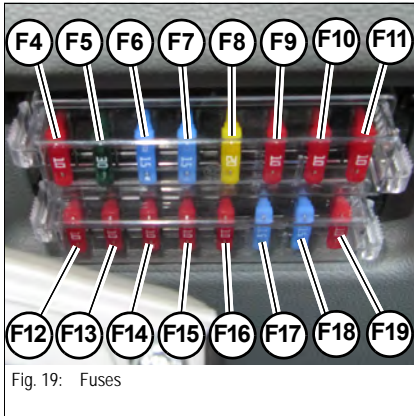

Fig. 19: Fuses

The fuses are located on the right of the operator seat.

Fuses	Rated current (A)	EW100
F4	10 A	Engine management, indicating instrument
F5	10 A	Machine controller inputs
F6	10 A	Cabin, wiper
F7	15 A	Heating, air conditioning ¹
F8	10 A	Clearance light
F9	10 A	Clearance light
F10	10 A	Low beam
F11	10 A	High beam
F12	10 A	Turn indicators
F13	15 A	Working lights ²
F14	15 A	Working lights
F15	15 A	Cabin controller
F16	15 A	Chassis controller
F17	15 A	Travel gear controller
F18	10 A	Radio, hazard warning system, rotating beacon, telematics, drive interlock
F19	15 A	12 V power outlet

1. from serial number WNCE0606CPAL01262: working lights

2. from serial number WNCE0606CPAL01262: heating, air conditioning system

Relays



Fig. 20:

The fuse box is located on the right side under the cabin.

Relays	EW100
K901	Turn indicators, working lights
K902	ECU engine
K7	Start high-current relay



2.19 Dimensions

EW100 triple articulation boom (overview)

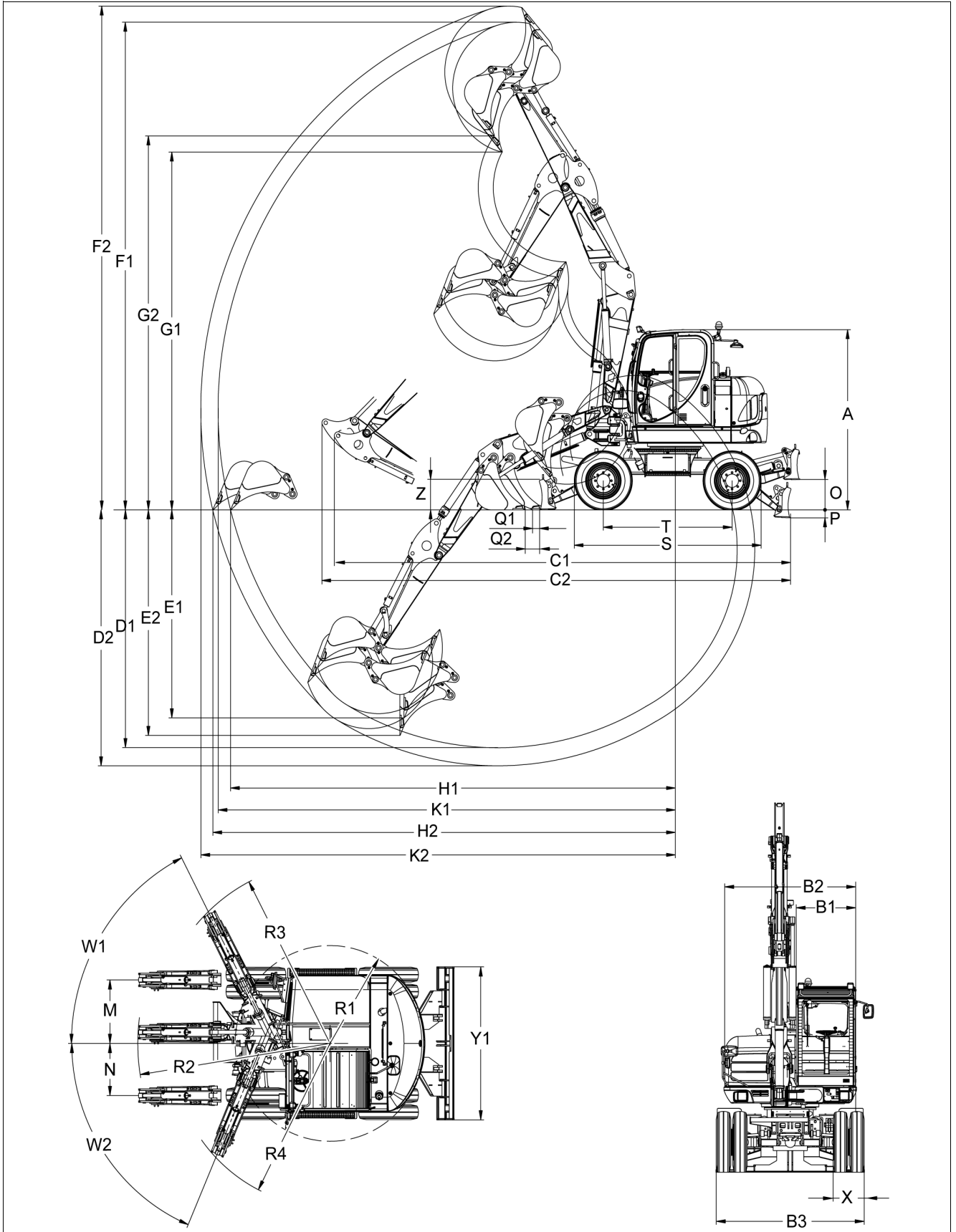



3.4 Important information regarding operation with biodegradable oil

- Use only the biodegradable oils that have been tested and released by Wacker Neuson Linz GmbH.
- Add only biodegradable oil of the same type. The joint use of two different biodegradable oils can affect the quality of one of the oil types. When replacing the biodegradable oil, always comply with national regulations and the manufacturer's specifications.
- In order to avoid misunderstandings, attach a label near the hydraulic oil filler inlet providing clear information regarding the type of oil currently used.
- Do not add any mineral oil to prevent foaming problems, and avoid negative effects on the biodegradability of the biodegradable oil.
- When running the vehicle with biodegradable oil, the same oil and filter replacement intervals are valid as for mineral oil.
- Always drain the condensation water in the hydraulic oil reservoir before the cold season. The water content may not exceed 0.1% by weight.
- The instructions in the Operator's Manual concerning environmental protection are also valid for the use of biodegradable oil.
- Additional hydraulic attachments must be filled with the same oil as the one in the hydraulic system of the excavator.

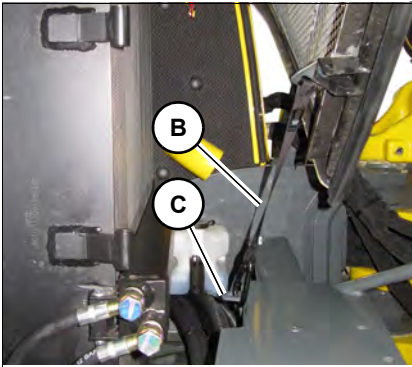

Fig. 25: Limiting the opening angle

Limiting the opening angle

- The opening angle of the engine cover can be limited by hitching belt **B** in lifting eye **C**.

Rocker cover



Caution!

Burn hazard due to hot hydraulic components!

Can cause serious burns.

- ☞ Allow the components to cool down.
- ☞ Wear protective equipment.



Notice!

A minimum 2 persons are required for installing/removing.

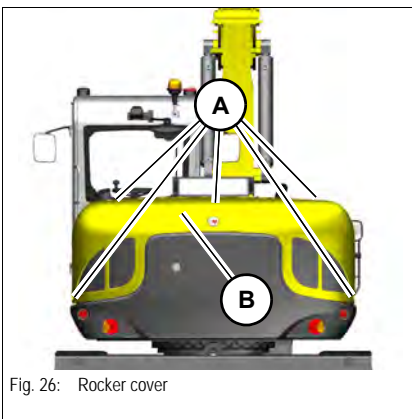

Fig. 26: Rocker cover

Removing:

- ☞ Stop and park the vehicle Stop the engine See "Preparing lubrication".
- ☞ Remove screws **A** with a suitable tool.
- ☞ Remove valve cover **B**.

Assembly:

- ☞ Position valve cover **B**.
- ☞ Install screws **A** with a suitable tool.

Refueling with the fuel-filling pump

- ☞ Unlock the maintenance door.
- ☞ Turn the starting key to position **1**.



Fig. 50: Maintenance door

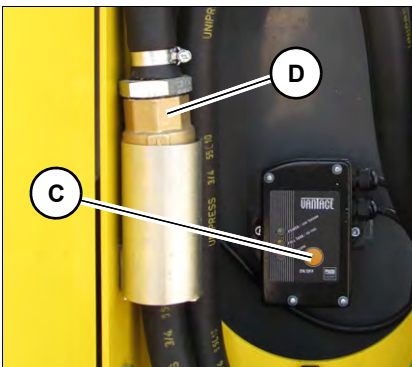

Fig. 51: Fuel-filling pump

- ☞ Insert the hose of fuel-filling pump **D** into the container with the fuel.
- ☞ Switch on the fuel-filling pump with switch **C**.
 - The green LED illuminates during refueling. The red LED indicates pumping has begun.
 - The tank sensor screwed into the fuel tank automatically switches off the fuel-filling pump.
 - Once refueling is over, the green LED (ON/OFF) and the yellow LED (FULL TANK/NO FUEL) illuminate.
- ☞ Switch off the fuel-filling pump with switch **C**.
 - About one minute after the last work step, the fuel-filling pump goes into standby mode.
- ☞ Close and lock the filler cap.

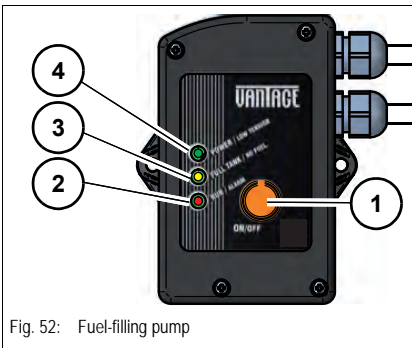
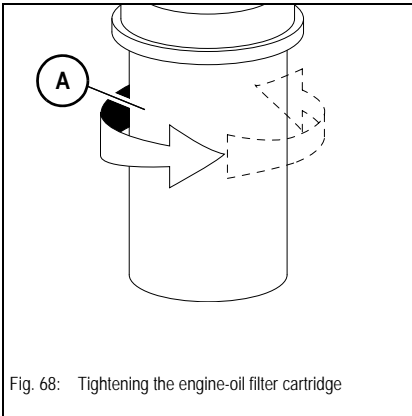

Fig. 52: Fuel-filling pump

Item	Designation	Function	LED
	ON/OFF	Start/stop refueling	-
	RUN/ALARM	- The red LED indicates pumping has begun. - Displays several alarm conditions	Red
	FULL TANK/NO FUEL	The reservoir is full, the yellow LED illuminates permanently.	Yellow
	POWER/LOW TENSION	- The fuel-filling pump is operational. - Displays several alarm conditions	Green



- ☞ Tighten engine-oil filter cartridge **A** by hand by about half a revolution.
- ☞ Ensure that the oil level is correct.
- ☞ Let the engine run briefly.
- ☞ Stop the engine
- ☞ Check the seal of engine-oil filter cartridge **A** and retighten by hand.
- ☞ Check the oil level and add engine oil if necessary.
- ☞ Completely remove all oil spills from the engine.
- ☞ Install the partition wall cover on the right with a suitable tool
– see Partition wall maintenance accesses on page 3-20.
- ☞ Lower the cabin – see Lowering the cabin on page 3-18.
- ☞ Close and lock the engine cover.
- ☞ Dispose of used engine-oil filter cartridges through approved methods for recycling.



Environment!

Use a suitable container to collect fluids and lubricants as they flow out and dispose of them in an environmentally friendly manner.

3.13 Washer system

Only use glass cleaner (with antifreeze if necessary) for refilling.

Checking the fluid level and adding fluid

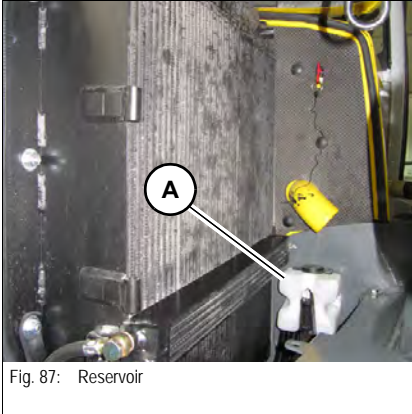

Fig. 87: Reservoir

The reservoir filler inlet is located on the left in the engine compartment.

- ☞ *Stop and park the vehicle Stop the engine See "Preparing lubrication".*
- ☞ *Open the engine cover.*
- ☞ *Check the fluid level in reservoir **A** and add fluid if necessary.*
- ☞ *Close and lock the engine cover.*

Planetary drive of rigid rear axle

Fig. 102: Rigid rear axle

**Notice!**

Drain oil only after running the machine for a longer period of time!

Checking the gearbox oil level

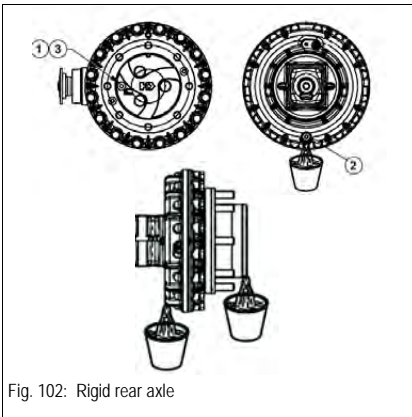
- ☞ Park the machine on level ground and prevent it from rolling away.
- ☞ Clean and loosen oil filler/check plugs **1** and **3** (possible overpressure can be released).
- ☞ Unscrew screws **1** and **3**.

If the oil level is below the opening or if the oil level cannot be seen at all:

- ☞ Add oil.

Adding gearbox oil

- ☞ Park the machine at operating temperature on level ground and prevent it from rolling away.
- ☞ Clean and loosen oil filler/check plugs **1** and **3** (possible overpressure can be released).
- ☞ Unscrew screws **1** and **3**.
- ☞ Add fresh oil through the opening until it overflows at the filler opening.
- ☞ Screw in screws **1** and **3** with a new sealing ring to make an oil-tight seal.

Changing gearbox oil

- ☞ Park the machine at operating temperature on level ground and prevent it from rolling away.
- ☞ Place a suitable receptacle under the planetary drive of the rear axle to collect the oil.
- ☞ Clean and unscrew plug **2** (to release possible overpressure).

Never raise the machine on one side only for the following work!

- ☞ Turn the planetary drive downward (plug must be at the bottom).
- ☞ Unscrew plug **2**.
- ☞ Completely drain the old oil.
- ☞ Retighten oil drain plug **2** with a new sealing ring to make an oil-tight seal.
- ☞ Add fresh oil through oil filler/check plugs **1** and **3** until it overflows.
- ☞ Screw in screws **1** and **3** with a new sealing ring to make an oil-tight seal.

**Environment!**

Use a suitable container to collect fluids and lubricants as they flow out and dispose of them in an environmentally friendly manner.

3.20 Hydraulic system



Important information on the hydraulic system



Caution!

Burn hazard due to hot hydraulic oil!

Hot hydraulic oil can cause burning to the skin, serious injury or death.





-  Release the pressure in the hydraulic system.
 -  Let the engine cool down.
 -  Wear protective equipment.
-



Caution!

Injury hazard due to fluid escaping under pressure!

Hydraulic oil escaping under pressure can penetrate the skin and cause serious injury or death.

-  Do not operate the vehicle with leaking or damaged hydraulic system components.
 -  Open the breather filter carefully to slowly release the pressure inside the reservoir.
 -  Wear protective equipment. If oil contacts the eye, flush immediately with clean water and seek medical treatment.
 -  Malfunctioning or leaking screw connections, hose connections and pressure lines must be immediately repaired (search for hydraulic leaks with a piece of cardboard).
-



Notice!

Damage due to wrong hydraulic oil.

- Use hydraulic oil according to **Fluids and lubricants**.
-



Notice!

Damage to hydraulic system due to incorrect hydraulic oil level.

- With a warm engine, the hydraulic oil must be about at the middle of the sight glass.
-



Position	Lubrication point	Interval	Quantity
1	Boom	Daily	2
2	Stick cylinder	Daily	2
3	Bucket cylinder	Daily	2
4	Boom cylinder	Daily	2
5	Joint rod	Daily	1
6	Shovel arm	Daily	2
7	Swiveling console	Daily	2
8	Swiveling cylinder	Daily	2
9	Live ring (ball bearing) – see <i>Lubricating the live ring (ball bearing)</i> on page 3-81	Every week	1
10	Live ring gears – see <i>Lubricating the teeth of the live ring</i> on page 3-82	1000 operating hours	1
11	Stabilizer leg	Daily	2
12	Stabilizer-leg cylinder	Daily	4
13	Stabilizer-blade rod	Daily	2
14	Stabilizer blade cylinder	Daily	4
15	Stabilizer blade	Daily	2
16	Upper and lower steering housing (standard)	Daily	4
	Upper and lower steering housing (2 steering axles option) – see <i>Steering housing</i> on page 3-79	Daily	8

Green means: lubrication every 50 hours or once a week.

Blue means: lubrication every 10 hours or daily.

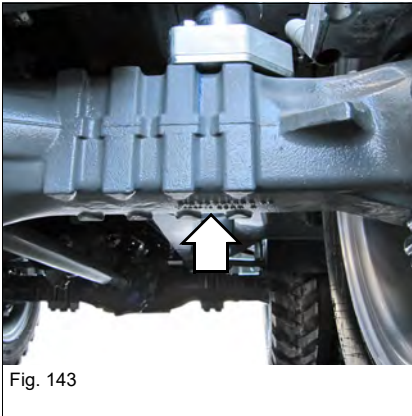

Fig. 143

Removing

- ☞ Stop and park the vehicle. Stop the engine. See "Preparing lubrication".
- ☞ Use wheel chocks to prevent the machine from rolling away.
- ☞ Loosen the wheel nuts of the wheel you want to remove.
- ☞ Apply the parking brake.
- ☞ Lock the service brake.
- ☞ Place a jack with a minimum lift capacity of 8000 kg (17,637 lbs) under the axle ensuring stability.
- ☞ Raise the side of the axle from which you want to remove the wheel.
- ☞ Check the machine is standing firmly.
- ☞ Secure the machine with trestles in appropriate places.



Notice!

Trestles must be positioned so as to avoid machine damage.

- ☞ Completely remove the wheel nuts.
- ☞ Remove the wheel.

Assembly

- ☞ Place the wheel onto the wheel bolts.
 - ☞ Bear in mind the correct direction of rotation of the tires.
- ☞ Tighten the wheel nuts.
 - ☞ Tighten the opposite wheel nut alternately.
- ☞ Remove the trestles.
- ☞ Lower the raised side of the machine.
- ☞ Tighten the wheel nuts to the specified torque of 450 Nm (332 ft. lbs.).
 - ☞ Tighten the opposite wheel nut alternately.



Notice!

After changing a wheel, check the wheel nuts for tightness after 10 operating hours. Retighten the wheel nuts if necessary.

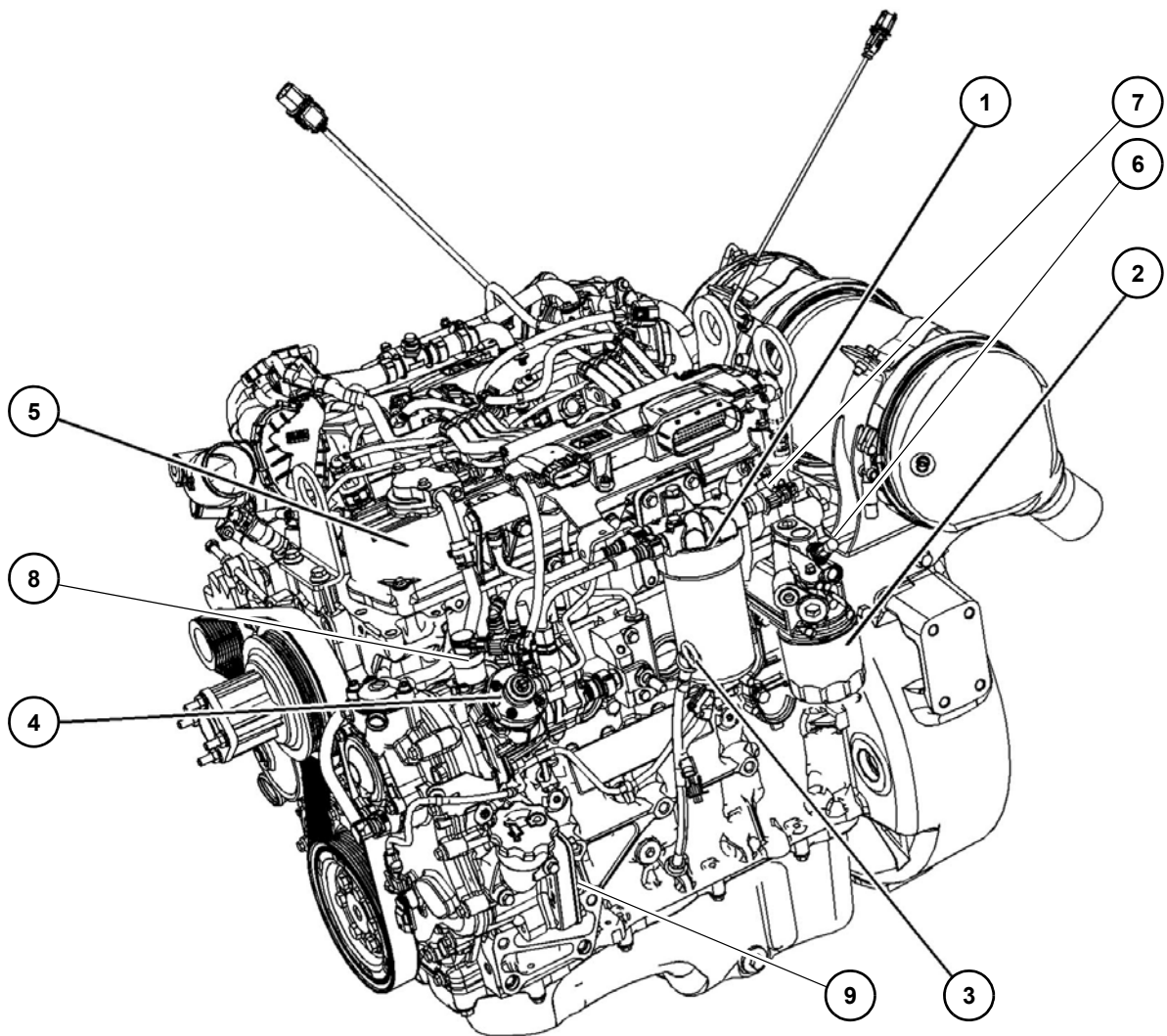

Symbolic representation

Item	Designation
1	Fine fuel filter
2	Oil filter
3	Oil dipstick
4	High-pressure fuel pump
5	cylinder-head cover
6	Oil pressure switch
7	Fuel temperature sensor
8	Fuel metering valve
9	Primary engine speed/ignition time sensor (crankshaft angle sensor)



Problem		Possible causes
Excessive development of	white smoke ¹	Low coolant temperature
		Separate cylinder not working correctly
		Valve clearance
		Fuel grade
		Low compression (cylinder pressure)
	Black smoke ²	Electronically regulated pump/nozzle units
		Air-intake and exhaust system
		Turbocharger
		Separate cylinder not working correctly
		Low compression (cylinder pressure)
		Valve clearance
		Malfunctioning particulate filter
Excessive valve clearance	Lubrication	
	Rocker arm	
	Valve linkage	
	Hydraulic tappet	
	Camshaft	
	Valve stems	
	Rocker-arm shaft	
Mechanical knocking of engine	Additional equipment	
	Valve train components	
	Piston	
	Connecting rod and main bearing	
Engine backfires, does not run smoothly or is unstable	Air-intake and exhaust system	
	Fuel supply	
	Throttle lever sensor	
	Fuel injection pump	
	Low compression (cylinder pressure)	
	Electronically regulated pump/nozzle units	
	Separate cylinder not working correctly	

1. After a longer standstill (for example over night), white smoke is normal when starting the engine and shortly afterward. Only condensation water evaporates.

2. Black smoke is visible only if the particulate filter is damaged.

5.4 Inching valve (omitted from serial no. WNCE0606HPAL00884)

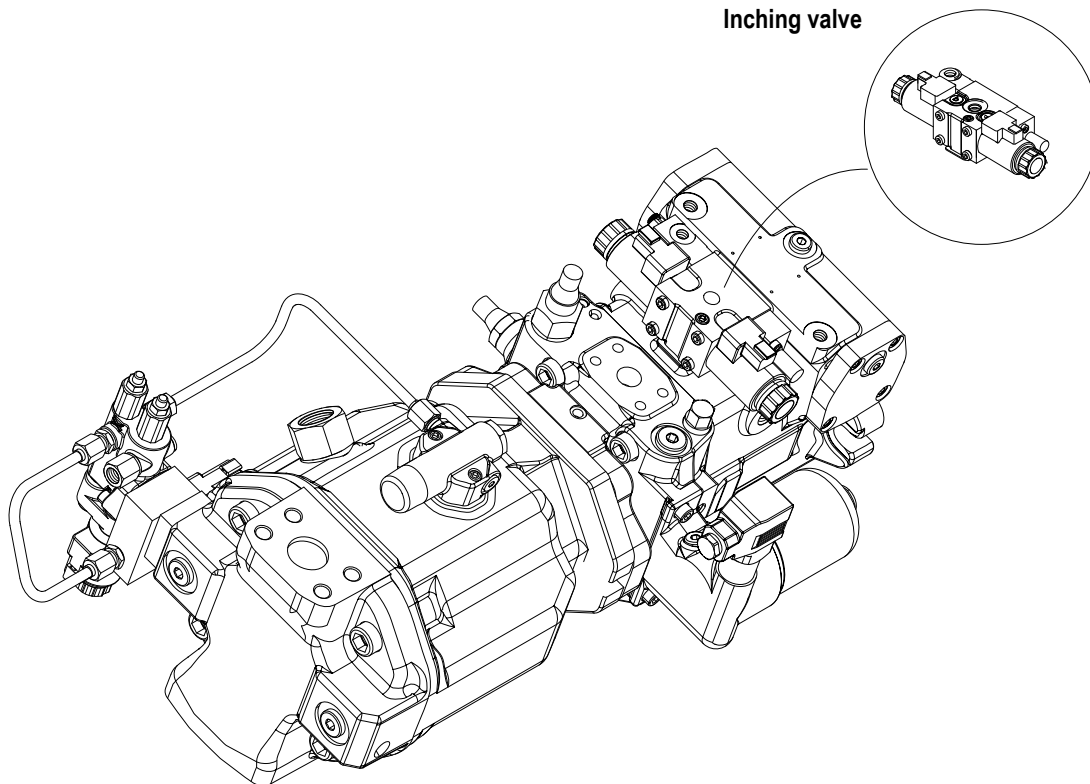

Inching function

The inching valve supports the service brake by reducing the wear on the brake linings. Only the hydrostatic drive brakes via the inching function when braking smoothly. Both the hydrostatic drive and the service brake when braking with more force. The control unit of the pump is connected with the circuit of the service brake. Increasing pressure in the braking system causes the hydraulic pump to swivel back.



Notice!

The inching function is used for braking the machine hydraulically before actuating the mechanical service brake.

Brakes

CLICK HERE TO **DOWNLOAD** THE COMPLETE MANUAL

- Thank you very much for reading the preview of the manual.
- You can download the complete manual from: www.heydownloads.com by clicking the link below



- Please note: If there is no response to CLICKING the link, please download this PDF first and then click on it.

CLICK HERE TO **DOWNLOAD** THE COMPLETE MANUAL

8.2 Hydraulic pump

Connections

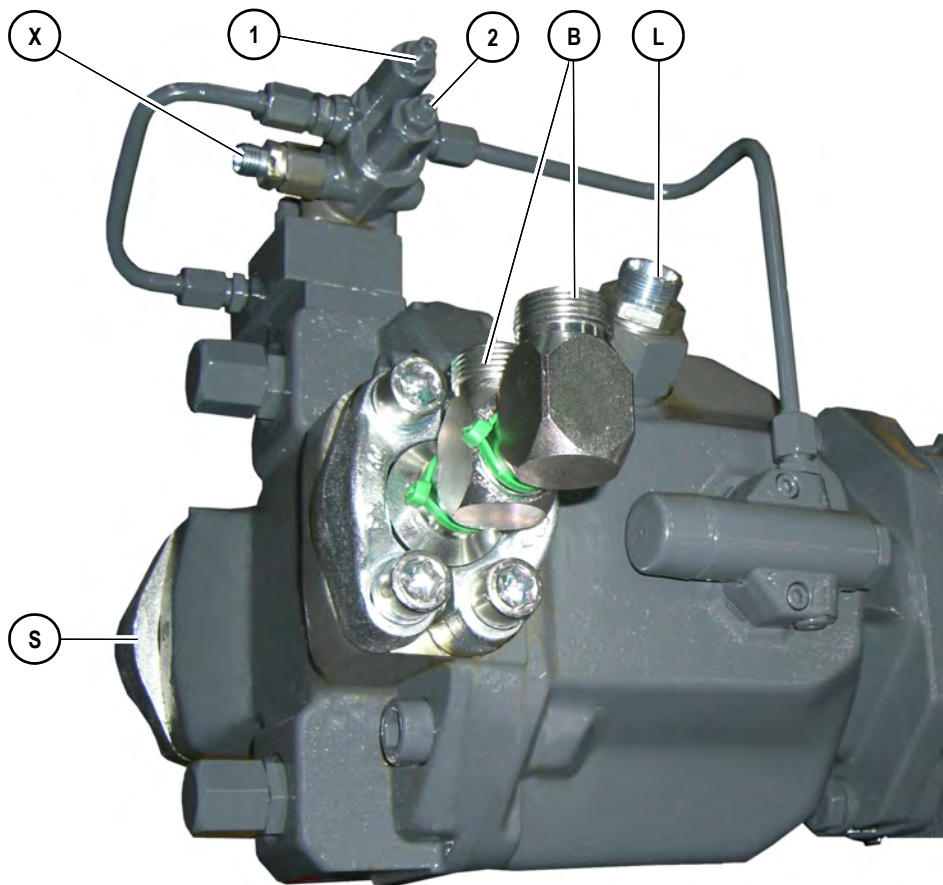

Item	Designation
B	Work line to main valve block connection "P" and "P3"
X	Control pressure to main valve block connection "LS"
1	Pressure regulator
2	Flow regulator
S	Suction line
L	Reservoir line

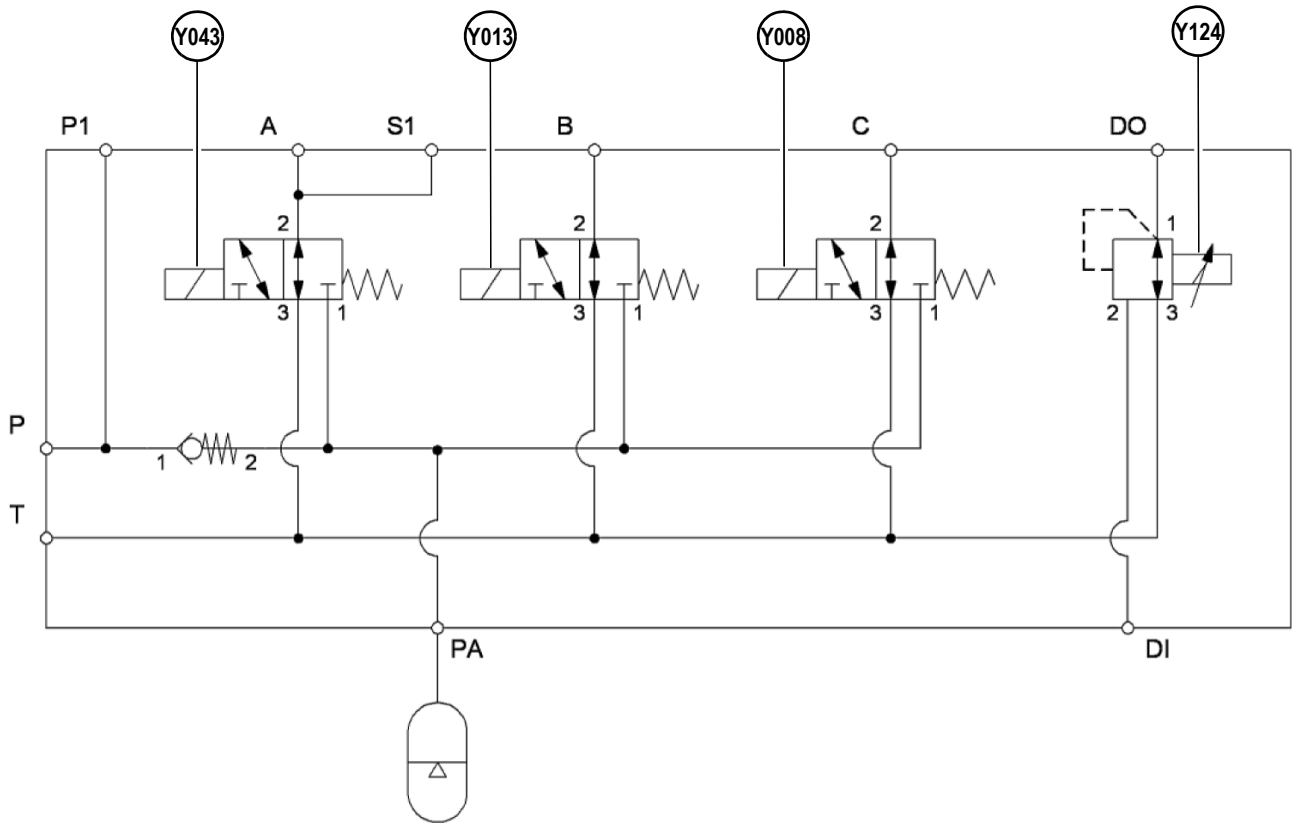
Pilot oil supply unit 20 kph (diagram)

Item	Designation
A	Via swivel joint to parking brake cylinder
S1	"Parking brake" S11 pressure switch
B	To oil supply for distributing block
C	Via swivel joint to oscillating-axle cylinder
P1	To gear motor release supply
DI	From connection PS of hydraulic pump
DO	To connection Y of hydraulic pump
T	Reservoir line
P	Oil supply for connection G = P1 hydraulic pump
PA	Pressure accumulator
Y043	Parking brake solenoid valve
Y013	Joystick OFF pilot control safety valve
Y008	Oscillating axle interlock solenoid valve
Y124	"Drive" solenoid valve PVM

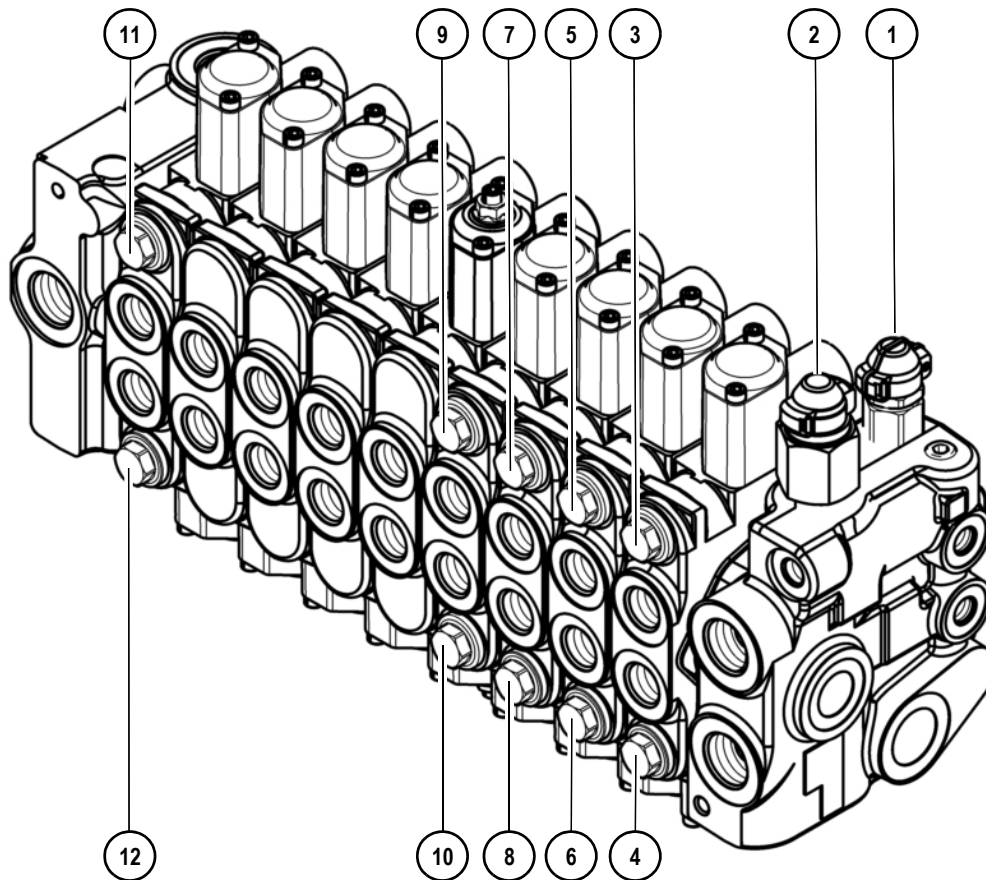
Pressure limiting valve

Item	Designation
1	LS pressure limiting valve
2	Inlet pressure compensator
3	Boom (rod side)
4	Boom (base side)
5	Stick (rod side)
6	Stick (base side)
7	Bucket (rod side)
8	Bucket (base side)
9	AUX I rod side (option)
10	AUX I base side (option)
11	AUX II rod side (option)
12	AUX II base side (option)



Diagram

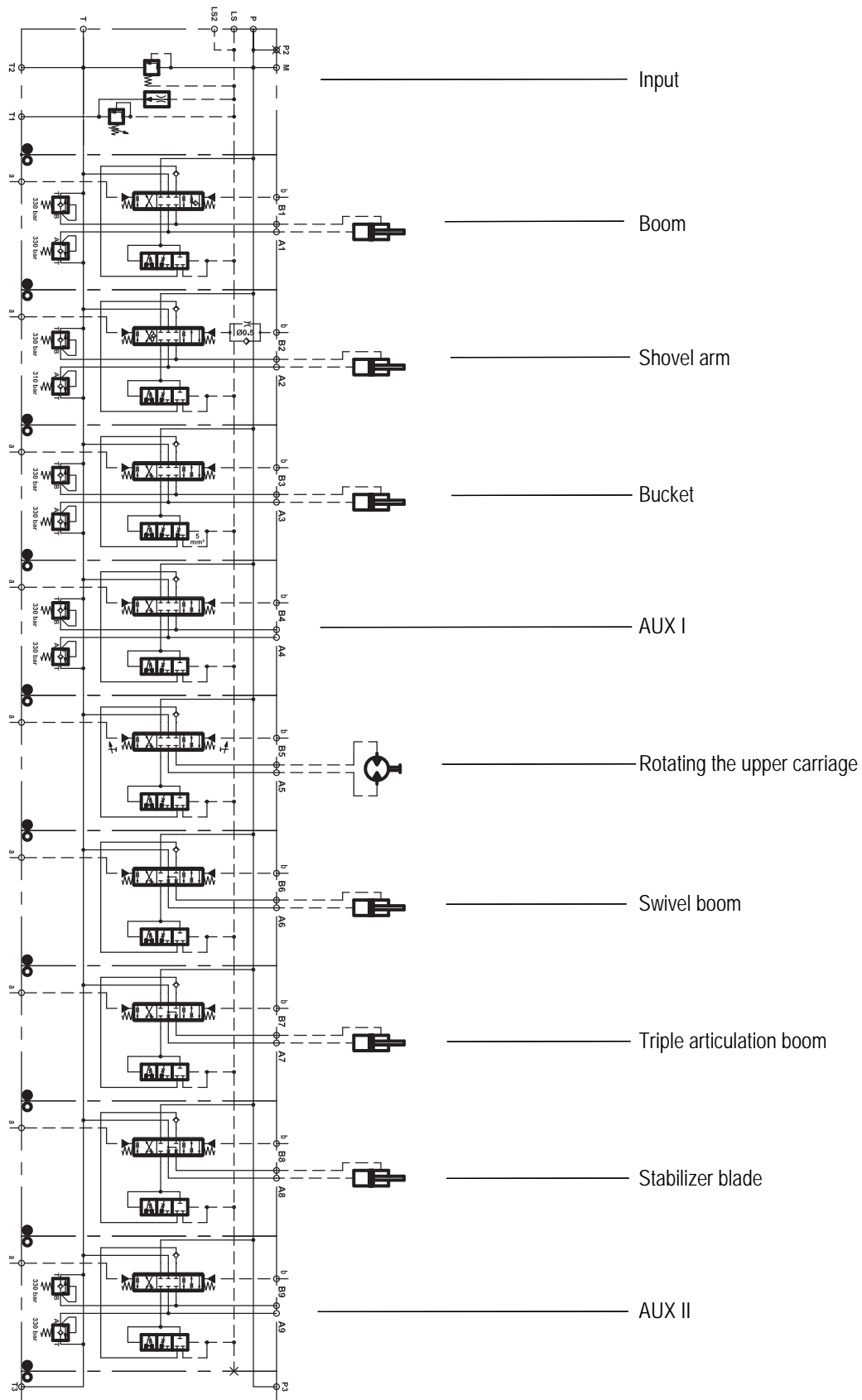

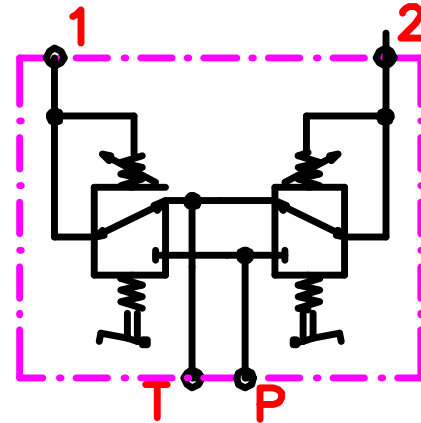
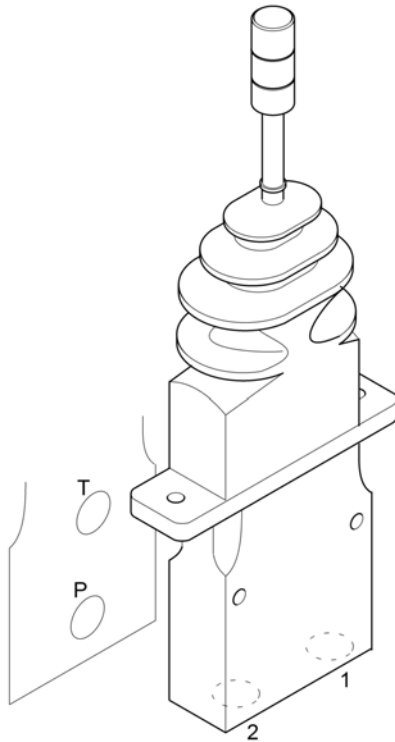
Stabilizer-blade valve

Item	Designation
1	to connection "Pa8" of main valve block
2	To connection "Pb8" of main valve block
P	Supply from pilot oil supply unit
T	Reservoir line



Performance diagram AUX I

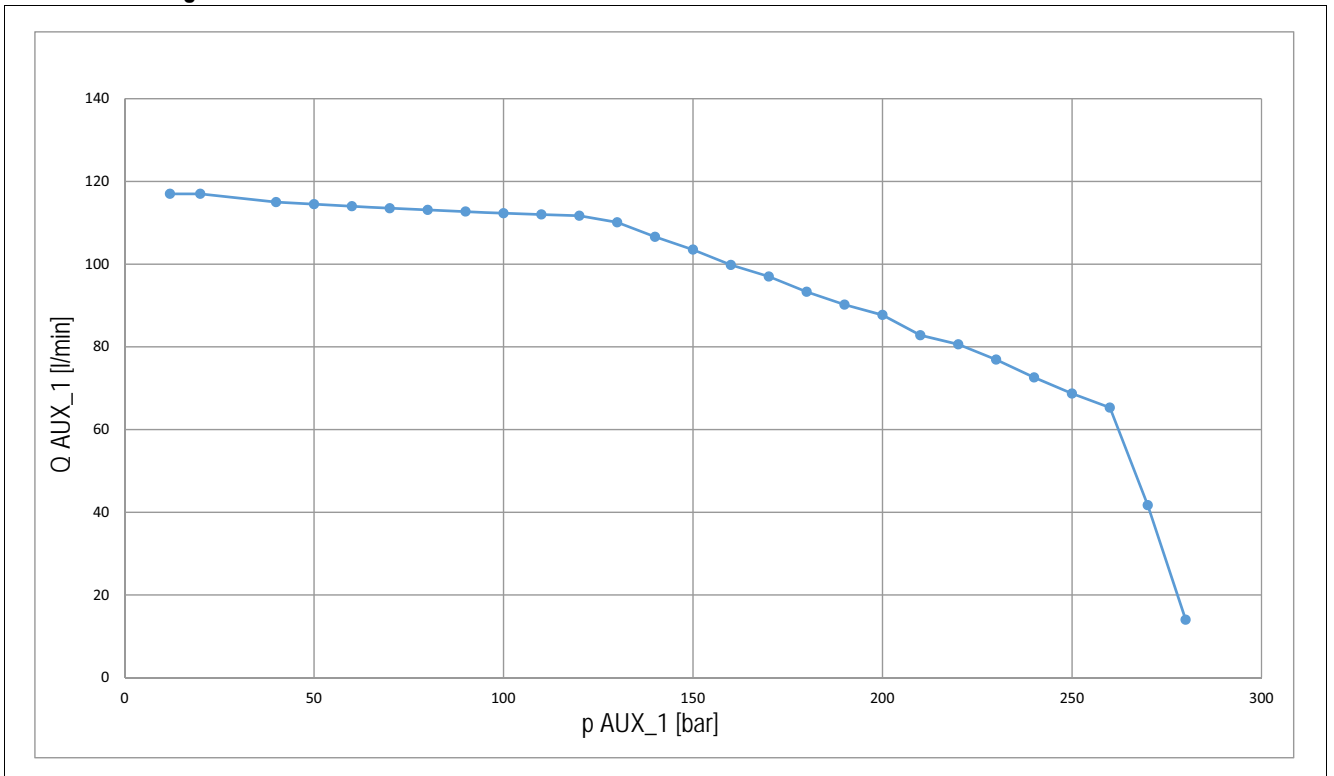

Performance diagram AUX II

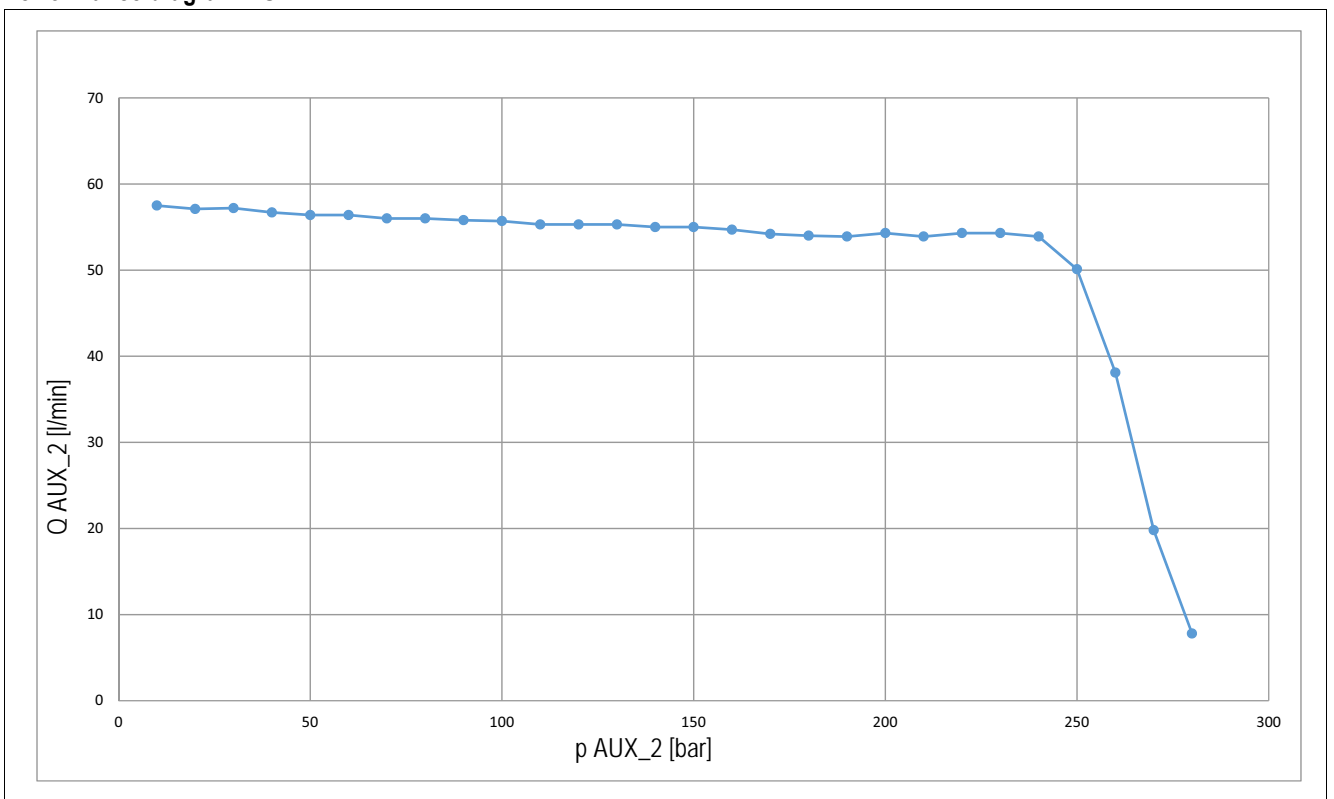

Access to board for electrical connections:

- ☞ Remove the cover.
- ☞ Unscrew the cable duct ring and the rubber seal, and pull the cable through it.
- ☞ Fasten the cable. (see Fig. 169 – Fig. 173)
- ☞ Screw on the cable duct ring and the rubber seal.
- ☞ Close the cover.

Main supply

Fig. 169: Main supply

- ☞ Connect the electric cable from the battery on the board.
 - ➔ Pay attention to the poles!
- ☞ Connect connector K1 to the positive terminal (+) of the battery.
- ☞ Connect connector K2 to the negative terminal (-) of the battery.

**Notice!**

The board is adjusted in the "VBAT" position with the jumper at the factory, and its power supply is ensured by the motor. This way the board has a constant consumption of 10 mA in the 24 V version or of 7.5 mA in the 12 V version in standby mode, too. If this consumption is too high for longer standstill times, the supply terminals have to be removed!

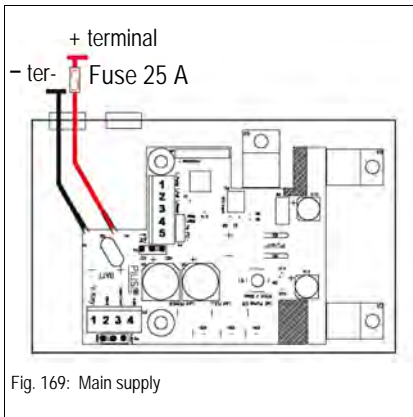
88	ECM A/35	EIC 2/30	0.75	pk	EGR engine negative	144	ECM K/54	X1/2	0.75	rd-wh	12 V 15 ECM engine
89	ECM A/9	EIC 2/33	0.75	pk	EGR position sensor supply	145	XF4_1	X1/2	0.75	rd-wh	12 V 15 ECM engine
90	ECM A/39	EIC 2/34	0.75	pk	EGR position sensor signal	146	XF4_1	R35/1	0.75	rd-wh	12 V 15 ECM engine
91	ECM A/24	EIC 2/35	0.75	pk	EGR position sensor ground	147	XF4_1	X28/2	0.75	rd-wh	12 V 15 ECM engine
92	ECM A/49	EIC 2/37	0.75	pk	TVA engine positive	150	G1	X1/9	0.75	pk	Charge indicator light
93	ECM A/34	EIC 2/38	0.75	pk	TVA engine negative	153	M7/4	X18/9	0.75	og	Full tank
94	ECM A/8	EIC 2/41	0.75	pk	TVA position sensor supply	156	EIC2/28	XF23	0.75	rd-wh	Battery A ECU
95	ECM A/53	EIC 2/42	0.75	pk	TVA position sensor signal	157	S58/3	XF23	0.75	rd-wh	Battery A ECU
96	ECM A/37	EIC 2/43	0.75	pk	TVA position sensor ground	158	B64/4	XF23	0.75	rd-wh	Battery A ECU
97	ECM A/4	EIC 2/27	0.75	pk	Electric waste gate valve actuator	265	Y5/1	X1/11	0.75	bu	Forward travel
100	ECM A/16	EIC 1/A	1.5	pk	Injector 1	266	Y4/1	X1/12	0.75	bu	Reverse travel
101	ECM A/32	EIC 1/B	1.5	pk	Injector 1	304	X18/11	B7/2	0.75	ye	Temp. Hydraulic oil
102	ECM A/31	EIC 1/C	1.5	pk	Injector 2	305	X28/3	X18/1	0.75	ye	Fan speed
103	ECM A/1	EIC 1/D	1.5	pk	Injector 2	308	Y11/1	X18/2	0.75	gn	Pump output
104	ECM A/17	EIC 1/E	1.5	pk	Injector 3	312	X28/6	X18/4	0.75	og	Fan
105	ECM A/48	EIC 1/F	1.5	pk	Injector 3	398	Y31/1	X18/5	1	bn	Air conditioning
106	ECM A/46	EIC 1/G	1.5	pk	Injector 4	420	GND2	ECM K/2	2.5	bk	Ground
107	ECM A/2	EIC 1/H	1.5	pk	Injector 4	421	GND2	ECM K/4	2.5	bk	Ground
111	ECM K/46	CAN-H	0.75	wh	CAN High	422	GND2	ECM K/6	2.5	bk	Ground
112	XE3/G	CAN-H	0.75	wh	CAN High	423	GND2	XGND1	1.5	bk	Ground
113	X1/6	CAN-H	0.75	wh	CAN High	424	Y5/2	XGND1	1	bk	Ground
115	ECM K/47	CAN-L	0.75	wh	CAN Low	425	Y4/2	XGND1	1	bk	Ground
116	XE3/F	CAN-L	0.75	wh	CAN Low	426	S58/2	XGND1	1	bk	Ground
117	X1/7	CAN-L	0.75	wh	CAN Low	427	XE3/B	XGND1	1	bk	Ground
119	X901/4	ECM K/28	0.75	bk-bn	Main relay	428	Y11/2	XGND1	1	bk	Ground
120	X902_3	F21/1	2.5	rd-wh	12 V 15	430	R35/2	XGND1	1	bk	Ground
121	X902_3	F22/1	2.5	rd-wh	12 V 15	431	X28/5	XGND1	0.75	bk	Ground
122	X902_3	F23/1	2.5	rd-wh	12 V 15	432	X28/1	XGND1	0.75	bk	Ground
123	F21/2	ECM K/3	2.5	rd-wh	Battery B ECU	433	GND2	X901/1	1	bk	Ground
124	F22/2	ECM K/5	2.5	rd-wh	Battery C ECU	434	GND2	M7/2	2.5	bk	Ground
125	F23/2	XF23	2.5	rd-wh	Battery A ECU	435	GND2	X1/13	1.5	bk	Ground
126	ECM K/1	XF23	2.5	rd-wh	Battery A ECU	436	Y31/2	XGND1	1	bk	Ground
132	XF4	X1/3	0.75	rd-wh	12 V 15 ECM engine	437	B7/2	XGND1	1	bk	Ground
139	XF4	X901/2	0.75	rd-wh	12 V 15 ECM engine	540	X902_2	F24/1	1	rd	12 V 30 controller
140	XF4	XE3/A	0.75	rd-wh	12 V 15 ECM engine	541	F24/2	X901/5	1	rd	12 V 30 controller
141	XF4	M7/3	0.75	rd-wh	12 V 15 ECM engine	542	F24/2	X18/10	0.75	rd	12 V 30 controller



9.16 Chassis wiring harness (up to serial number WNCE0606EPAL00692)

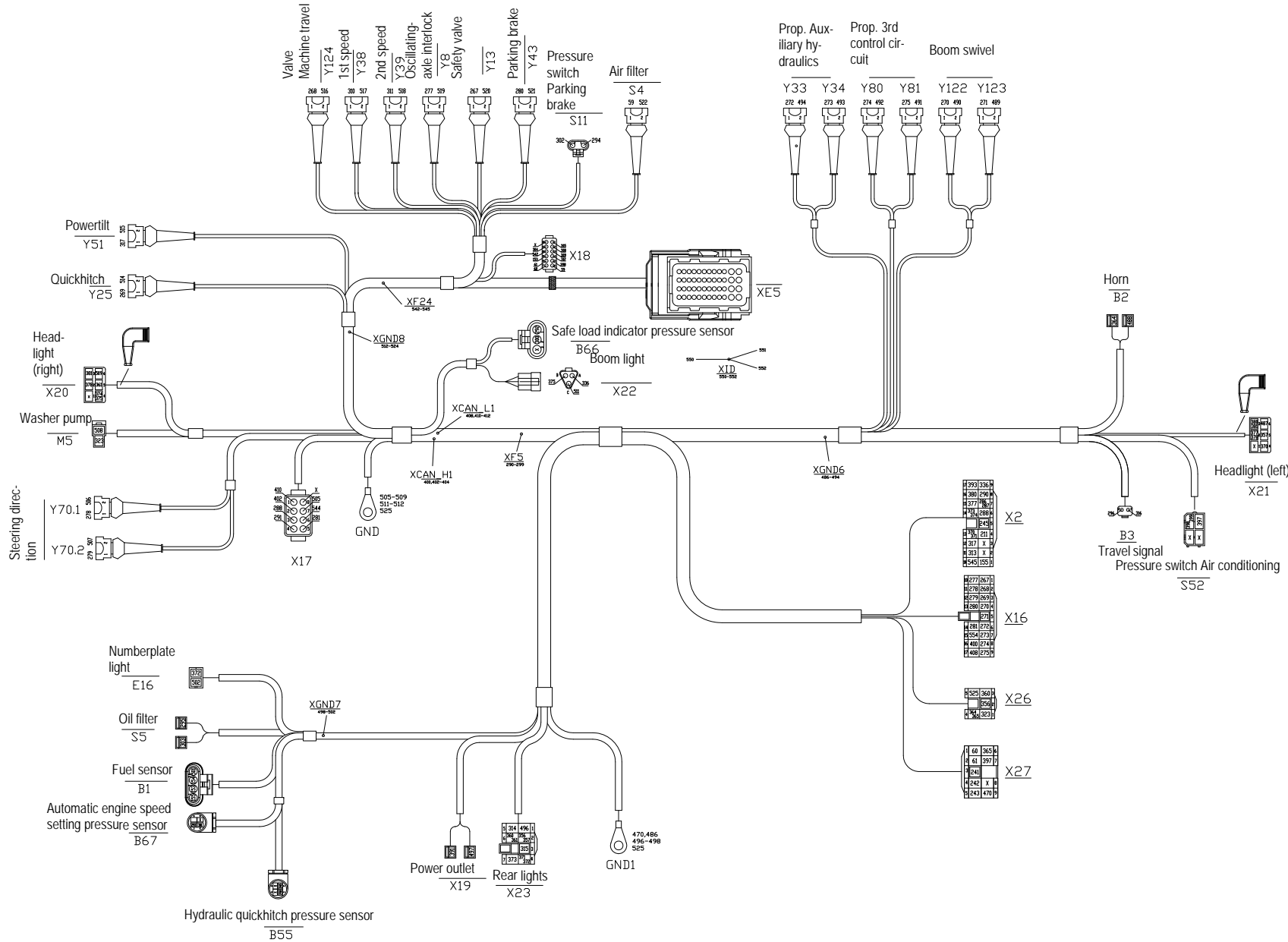

XE 5		
A1	316	G1
A2	412	G2
A3	241	G3 309
A4	242	G4 303
B1	554	H1 308
B2	411	H2
B3	299	H3 550
B4	243	H4 304
C1	313	J1 315
C2	403	J2
C3	399	J3 552
C4	211	J4 154
D1	312	K1 314
D2	404	K2
D3	305	K3 551
D4	300	K4 297
E1	311	L1 543
E2		L2 286
E3		L3 524
E4	301	L4
F1	310	M1 287
F2		M2
F3	523	M3
F4	302	M4



**WACKER
NEUSON**

Electrical system

218	X7/3	XE1/46	0.75	gn	Hydraulic quickhitch	273	X16/7	XE1/40	0.75	gn	Auxiliary hydraulics 2
220	XE1/42	X25/8	0.75	bl	Parking brake NO	274	X16/8	XE1/38	0.75	gn	3rd control circuit 1
221	XE1/48	X25/9	0.75	bl	Parking brake NC	275	X16/9	XE1/37	0.75	gn	3rd control circuit 2
222	XE2/57	X7/10	0.75	gn	Front stabilizer legs	276	B19/1	XE1/30	0.75	vt	Buzzer
223	XE2/63	X7/11	0.75	gn	Rear stabilizer legs	277	X16/10	XE1/39	0.75	gn	Oscillating-axle interlock
224	XE2/55	X7/7	0.75	gn	Stabilizer legs (left)	278	X16/11	XE1/31	0.75	bu	Steering direction 1
225	XE2/61	X7/8	0.75	gn	Stabilizer legs (right)	279	X16/12	XE1/32	0.75	bu	Steering direction 2
226	XE1/43	X25/6	0.75	gn	Brake pressure accumulator	280	X16/13	XE1/51	0.75	bu	Parking brake
227	XE2/74	X25/5	0.75	ye	Brake light sensor	281	X16/14	XE2/69	0.75	bu	Front axle steering
228	X8/1	XE1/7	0.75	ye	Travel speed control	282	S22/10	XE2/80	0.75	bu	Front axle steering indicator light
229	X8/2	XE1/6	0.75	ye	Hammer button	283	S73/B	XE2/79	0.75	bu	4 wheel steering indicator light
230	X8/3	XE1/24	0.75	ye	Forward travel	284	S73/10	XE2/78	0.75	bu	Crab steering indicator light
231	X8/4	XE1/12	0.75	ye	Reverse travel	285	K108/30	F16/5	1	rd	12 V controller chassis
232	X8/5	XE1/26	0.75	ye	Auxiliary hydraulics	286	X2/7	F16/5	1	rd	12 V controller chassis
233	X8/6	XE1/14	0.75	ye	Auxiliary hydraulics red.	288	X2/6	F17/6	1	rd	12 V controller chassis
235	X8/7	XE1/25	0.75	ye	3rd control circuit	290	X2/8	X7/4	0.75	rd-wh	12 V switch
236	X8/8	XE1/13	0.75	ye	3rd control circuit red	313	X2/11	K108/86	0.75	bu	Powertilt
238	X8/10	XE1/11	0.75	ye	Neutral	317	X2/12	K108/87	1	bu	Powertilt
239	X25/3	XE2/60	0.75	ye	Accelerator pedal	319	X12/6	X12/7	1	rd-wh	12 V cabin, wiper
240	X25/4	XE2/67	0.75	ye	Accelerator pedal	320	X12/6	F6/3	1	rd-wh	12 V cabin, wiper
242	X7/9	XE1/21	0.75	ye	Swivel boom	321	X15/8	F6/3	1	rd-wh	12 V cabin, wiper
244	X8/13	XE1/41	0.75	ye	Manual throttle	325	X12/1	X15/10	1	og	Reset
245	X2/5	XE2/53	0.75	ye	Hydraulic quickhitch sensor	326	X12/4	X15/11	1	og	Wiper
247	X8/11	XE1/16	0.75	ye-wh	5V_1	329	S16/5	F7/4	1	rd-wh	12 V working light
254	X25/12	XE1/4	0.75	ye-wh	5V_2	330	S16/5	S16/10	1	rd-wh	12 V working light
255	X8/12	XE1/22	0.75	ye-bn	0V_1	331	S17/1	F14/3	1.5	rd-wh	12 V working light
259	X25/13	XE1/10	0.75	ye-bn	0V_2	332	S17/1	S17/2	1	rd-wh	12 V working light
262	S80/1	S80/B	0.75	bu	Steering direction NO	333	S17/10	S17/2	1	rd-wh	12 V working light
263	S80/1	XE2/56	0.75	bu	Steering direction NO	334	S17/10	S18/10	1	rd-wh	12 V working light
264	S80/7	XE2/62	0.75	bu	Steering direction NC	335	S16/B	S16/1	1	vt	Boom working light
265	X1/11	XE2/75	0.75	bu	Forward travel	336	X2/9	S16/1	1	vt	Boom working light
266	X1/12	XE2/68	0.75	bu	Reverse travel	337	S17/B	S17/6	1	vt	Front roof lights
267	X16/1	XE1/36	0.75	gn	Safety valve	338	X12/5	S17/6	1	vt	Front roof lights
268	X16/2	XE2/76	0.75	bu	Travel valve	339	X12/9	S17/3	1	vt	Rear roof light
269	X16/3	XE1/35	0.75	gn	Quickhitch valve	341	F13/2	X7/2	1	rd-wh	12 V heating, air conditioning
270	X16/4	XE1/33	0.75	gn	Boom swivel 1	350	X15/1	F12/1	1	rd-wh	12 V turn indicators, horn
271	X16/5	XE1/34	0.75	gn	Boom swivel 2	352	X15/2	K10/CL	1	gy	Turn indicators CL
272	X16/6	XE1/52	0.75	gn	Auxiliary hydraulics 1	354	X15/3	K10/+	1	gy	Turn indicators +



**WACKER
NEUSON**

Electrical system

9.30 Seat console wiring harness legend

No.	From	To	mm ²	Color	Function	No.	From	To	mm ²	Color	Function
60	X27/1	S119/1	0.75	pk	Regeneration switch	233	X9/6	X8/6	0.75	ye	Auxiliary hydraulics red.
61	X27/2	S119/7	0.75	pk	Regeneration switch (disable)	234	X10/3	X27/4	0.75	ye	Spare
134	S119/3	X7/1	0.75	rd-wh	12 V 15 ECM engine	235	X13/3	X8/7	0.75	ye	3rd control circuit
135	S119/3	S119/10	0.75	rd-wh	12 V 15 ECM engine	236	X13/4	X8/8	0.75	ye	3rd control circuit red
136	S119/B	S119/10	0.75	rd-wh	12 V 15 ECM engine	237	X13/5	X8/9	0.75	ye	Spare
167	XF5	X7/4	0.75	rd-wh	12 V switch	238	X9/8	X8/10	0.75	ye	Neutral
180	S40/5	XF5	0.75	rd-wh	12 V switch	241	X11/3	X27/3	0.75	ye	Powertilt
181	S40/5	S40/6	0.75	rd-wh	12 V switch	242	X9/10	X7/9	0.75	ye	Swivel boom
	S40/6	S40/10	0.75	rd-wh	12 V switch	243	X11/5	X27/5	0.75	ye	Automatic engine speed setting
182	S76/3	S40/10	0.75	rd-wh	12 V switch	244	R12/B	X8/13	0.75	ye	Manual throttle
183	S76/6	S76/10	0.75	rd-wh	12 V switch	246	X5V1	X11/1			
184	S76/B	S76/10	0.75	rd-wh	12 V switch	247	X5V1	X8/11	0.75	ye-wh	5V_1
185	S76/B	S75/3	0.75	rd-wh	12 V switch	248	X5V1	X9/1	0.75	ye-wh	5V_1
186	S75/10	S75/6	0.75	rd-wh	12 V switch	249	X5V1	R12/A	0.75	ye-wh	5V_1
187	S75/10	S75/B	0.75	rd-wh	12 V switch	250	X5V1	X13/1	0.75	ye-wh	5V_1
188	S28/1	S75/B	0.75	rd-wh	12 V switch	251	X5V1	X9/9	0.75	ye-wh	5V_1
193	X10/1	XF5	0.75	rd-wh	12 V switch	255	X0V1	X8/12	0.75	ye-bn	0V_1
194	S75/6	S75/3	0.75	rd-wh	12 V switch	256	X0V1	X9/2	0.75	ye-bn	0V_1
195	S76/6	S76/3	0.75	rd-wh	12 V switch	257	X0V1	R12/C	0.75	ye-bn	0V_1
196	X11/1	XF5	0.75	rd-wh	12 V switch	258	X0V1	X13/2	0.75	ye-bn	0V_2
198	S28/2	X8/14	0.75	gn	Safety switch NO	341	X14/1	X7/2	1	rd-wh	12 V heating, air conditioning
199	S28/4	X7/5	0.75	gn	Safety switch NC	342	X14/1	S15/1	1	rd-wh	12 V heating, air conditioning
216	S40/1	S40/B	0.75	gn	Hydraulic quickhitch	343	S15/2	S15/1	1	rd-wh	12 V heating, air conditioning
217	S40/1	X7/6	0.75	gn	Hydraulic quickhitch	344	S15/2	S15/10	1	rd-wh	12 V heating, air conditioning
218	S40/5	X7/3	0.75	gn	Hydraulic quickhitch	345	S15/8	S15/B	1	bn	1st fan speed
222	S75/1	X7/10	0.75	gn	Front stabilizer legs	346	S15/6	M4/1	1	bn	1st fan speed
223	S75/8	X7/11	0.75	gn	Rear stabilizer legs	347	S15/3	M4/3	1	bn	2nd fan speed
224	S76/1	X7/7	0.75	gn	Stabilizer legs (left)	348	X24/2	S15/10	1	rd-wh	12 V heating, air conditioning
225	S76/8	X7/8	0.75	gn	Stabilizer legs (right)	397	X14/3	X27/7	1	bn	Air conditioning
228	X9/7	X8/1	0.75	ye	Travel speed control	470	M4/2	X27/9	1	bk	Ground
229	X11/4	X8/2	0.75	ye	Hammer button	471	M4/2	XGND4	1	bk	Ground
230	X9/3	X8/3	0.75	ye	Forward travel	472	X11/2	XGND4	0.75	bk	Ground
231	X9/4	X8/4	0.75	ye	Reverse travel	473	S28/3	XGND4	0.75	bk	Ground
232	X9/5	X8/5	0.75	ye	Auxiliary hydraulics	474	S119/9	XGND4	0.75	bk	Ground
475	S119/9	S40/9	0.75	bk	Ground						

10.38 Hydraulics diagram (from serial number WNCE0606PPAL01135)

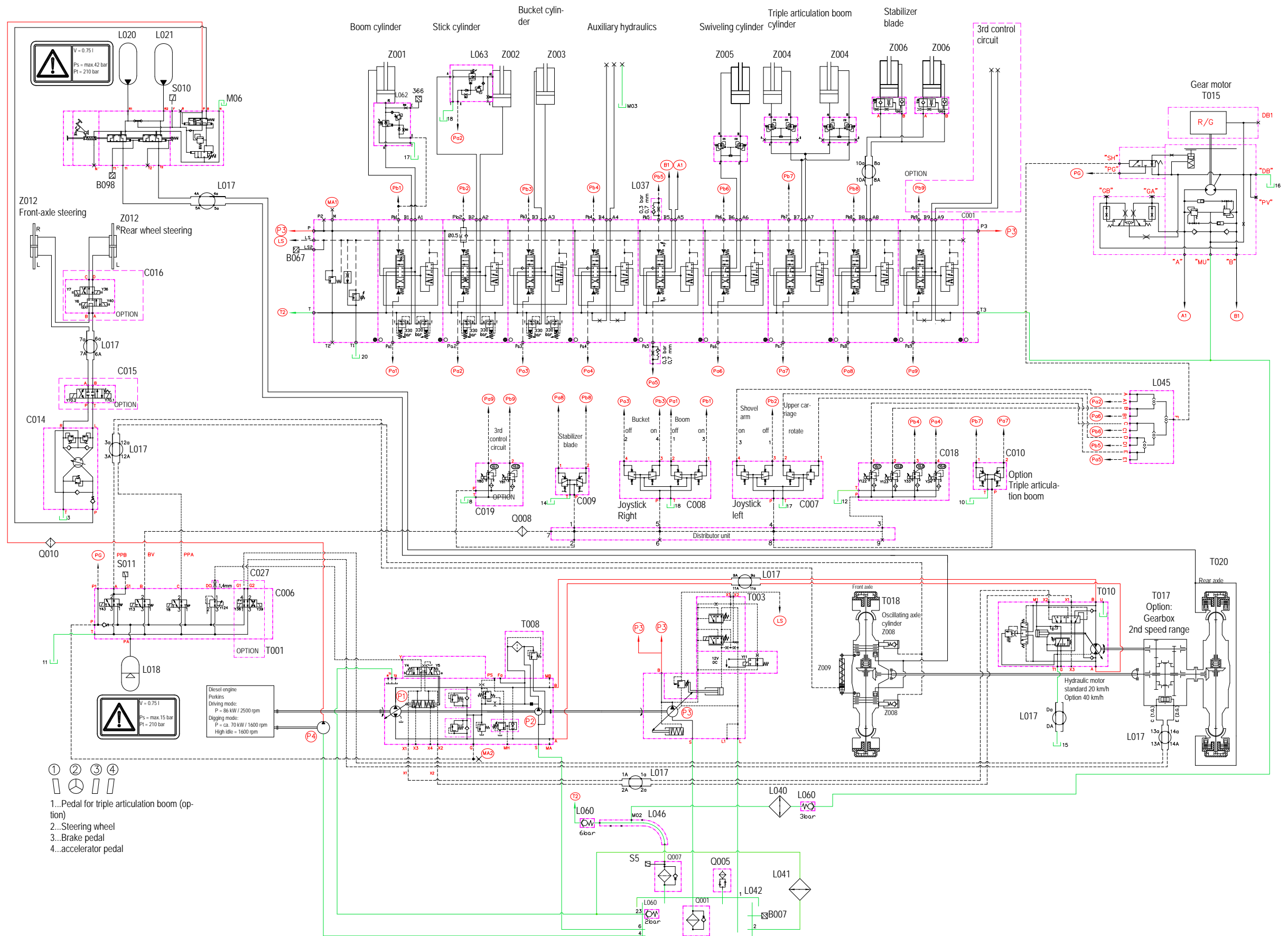

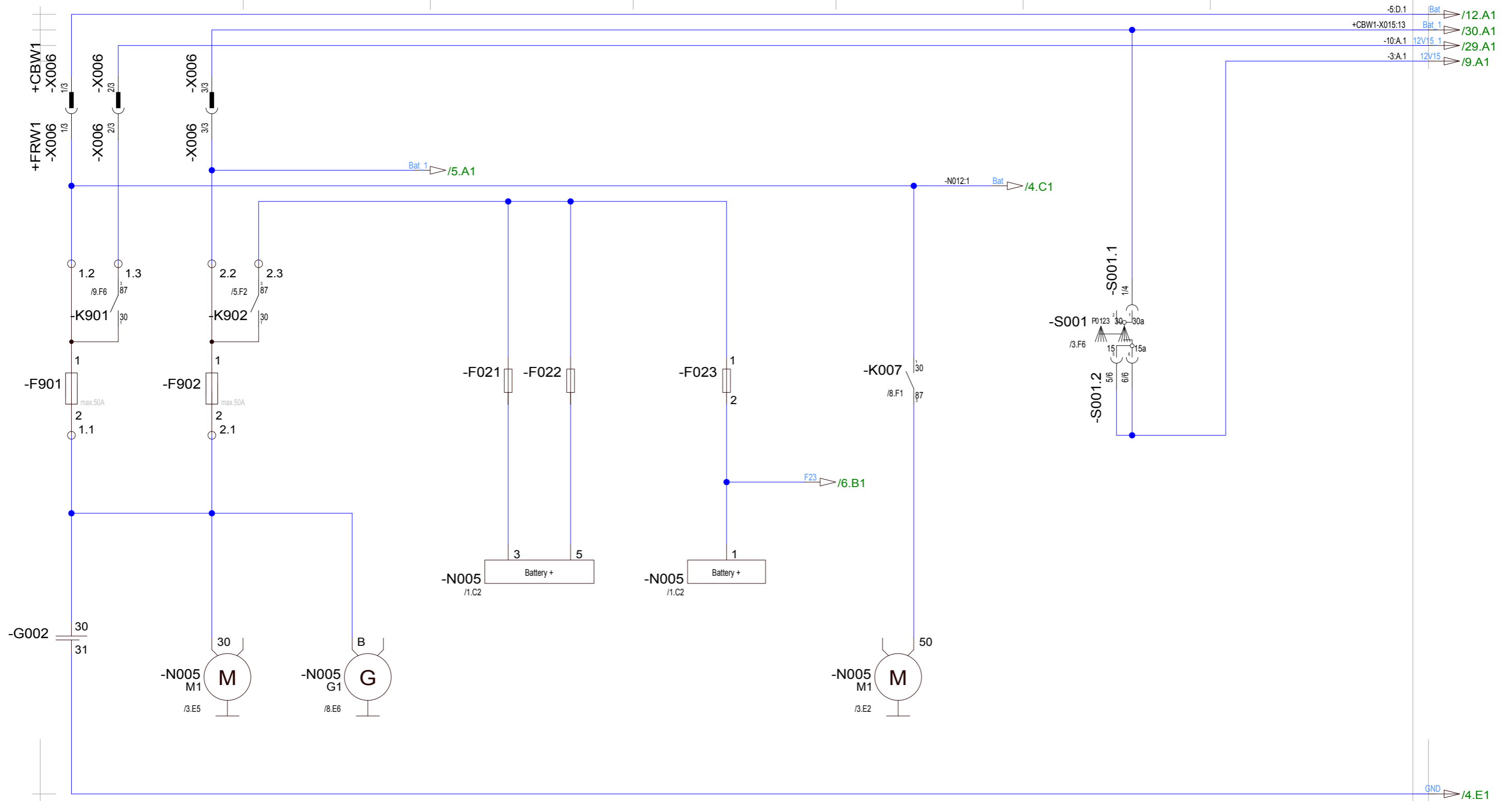

- 5.D.1 Bat 1 /12.A1
- +CBW1-X015:13 Bat 1 /30.A1
- 10.A.1 12V15 1 /29.A1
- 3.A.1 12V15 /9.A1

Bat 1 /5.A1

-N012:1 Bat /4.C1

F23 /6.B1

GND /4.E1

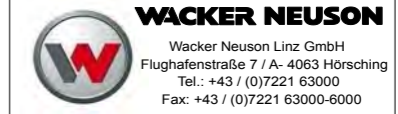
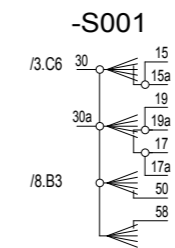

Diese Zeichnung darf ohne unsere ausdrückliche Genehmigung weder vervielfältigt, noch dritten Personen oder Mitbewerbern im Original oder als Kopie ausgehändigt werden. Eigentums- und Urheberrecht vorbehalten.

Hauptversorgung ED_EW100		3/33
Mat.-Nr. 1000300739	Doc.-Nr. 2060035159_04	A3

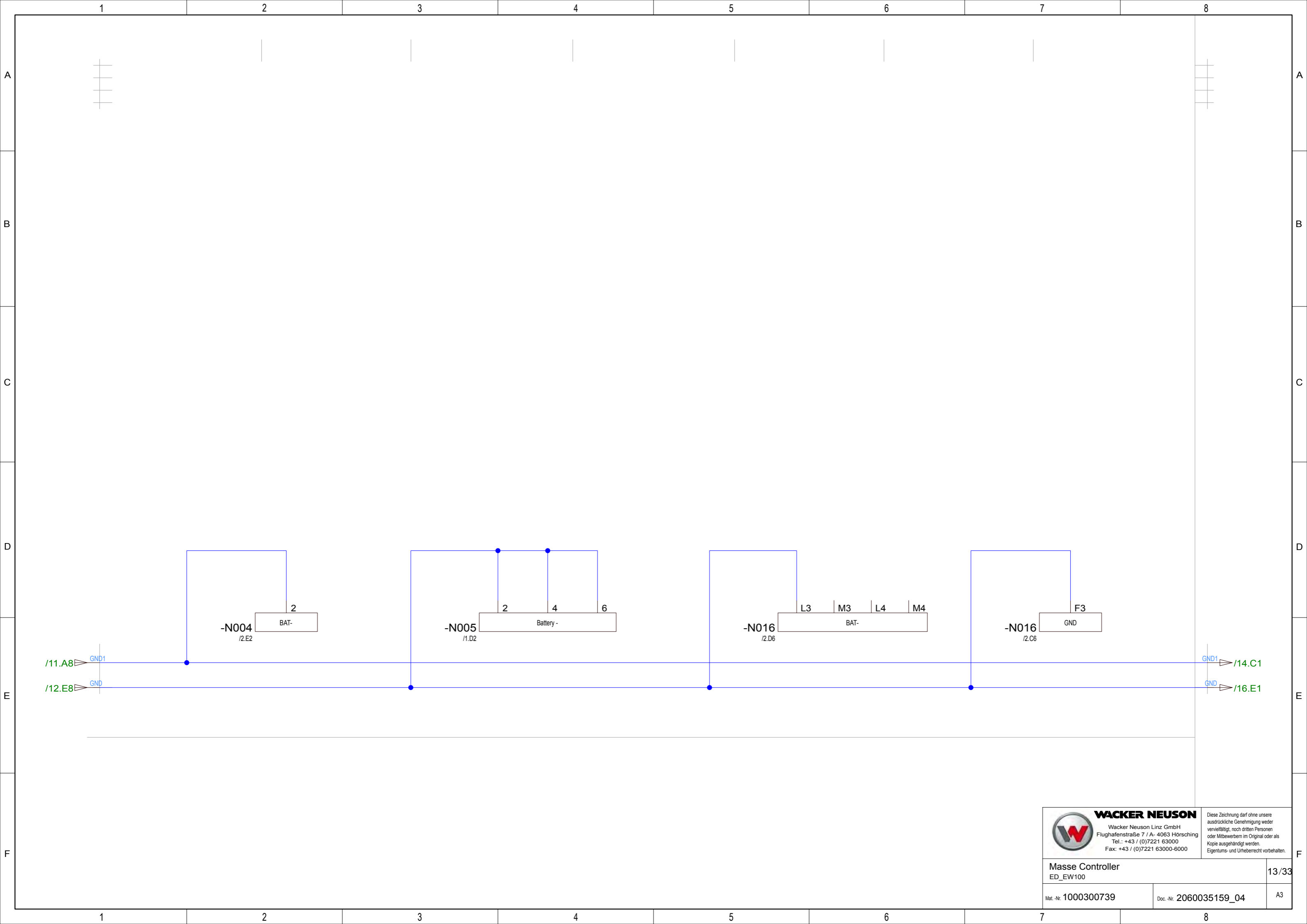

Diese Zeichnung darf ohne unsere ausdrückliche Genehmigung weder vervielfältigt, noch dritten Personen oder Mitbewerbern im Original oder als Kopie ausgehändigt werden. Eigentums- und Urheberrecht vorbehalten.

Masse Controller ED_EW100		13/33
Mat.-Nr. 1000300739	Doc.-Nr. 2060035159_04	A3

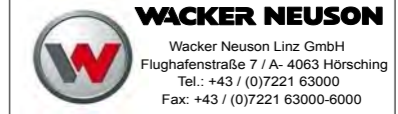
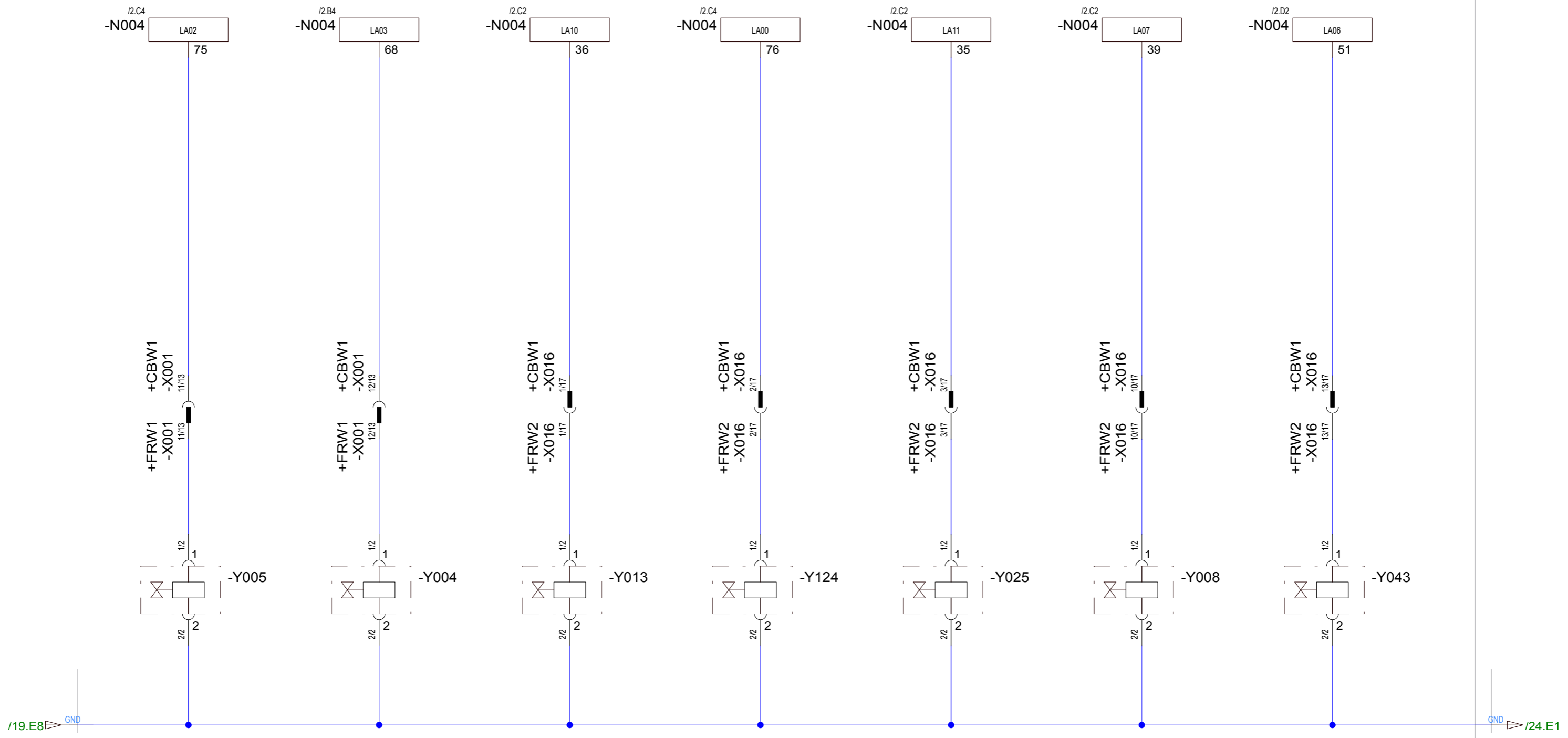

WACKER NEUSON
 Wacker Neuson Linz GmbH
 Flughafenstraße 7 / A- 4063 Horsching
 Tel.: +43 / (0)7221 63000
 Fax: +43 / (0)7221 63000-6000

Diese Zeichnung darf ohne unsere ausdrückliche Genehmigung weder vervielfältigt, noch dritten Personen oder Mitbewerbern im Original oder als Kopie ausgehändigt werden. Eigentums- und Urheberrecht vorbehalten.

Ventile Fahren
 ED_EW100

Mat.-Nr. 1000300739 Doc.-Nr. 2060035159_04 A3

Options



11.5 “Hose burst valve” safety feature



Danger!

The “Hose burst valve” safety feature is activated as soon as a hose or a pipe bursts –

Accident hazard!

☞ *Have damage to the hydraulic system and to the hose burst valve itself immediately repaired and checked by technical personnel with suitable training*



Notice!

In the event of a bursting hose or pipe, the “Hose burst valve” safety feature prevents the boom from being lowered or dumped out without being braked.

☞ *Stop and park the vehicle Stop the engine See “Preparing lubrication”.*

☞ *Secure the machine and the attachment.*



Environment!

Use a suitable container to collect fluids and lubricants as they flow out and dispose of them in an environmentally friendly manner.



Exhaust gas temperature before SCR	B090	517089		
Urea pressure after pump	B091	517090		
DS DPF pressure	B092	517091		
NOx sensor after SCR cat	B093	517092		
NOx sensor before SCR cat	B094	517093		
Urea quality, level, temperature	B095	517094		
Delta P Venturi	B096	517095		
EGR temperature after Venturi	B097	517096		
SWS pressure sensor	B098	517097		
Stabiliser blade joystick	B099	517098		
Swivel stabiliser blade joystick	B100	517099		
Fuel pump level sensor	B101	517100		
Rear three-point linkage load pressure sensor	B102	517101		
Current sensor	B103	517102		
Speed sensor, PTO shaft (CAN)	B104	517103		0x52
Joystick, rear linkage three point	B105	517104		
Pressure sensor, air conditioning	B106	517105		
Pressure sensor, brake	B107	517106		
Urea level, temperature	B108	517107		
DEF catalytic converter inlet temperature sensor signal	B109	517108		
DEF catalytic converter outlet temperature sensor signal	B110	517109		
NH3 ammonia sensor	B111	517110		
Battery acid filling level	B112	517111		
Manual throttle	B113	517112		
Bucket repositioning angle of rotation (signal 2)	B028.2	517113		
Rear three-point linkage joystick (signal 2)	B105.2	517114		
Sensor steering movement	B114	517115		
Position sensor activity potentiometer	B115	517116		
Supply contacts (electrical system)	BAT	517400-517449		
Watchdog	BAT1	517400		
Reference voltage	BAT2	517401		
Injection channel	BAT3	517402		
Battery voltage	BAT4	517403		
Sensor voltage	BAT5	517404		
Forward-reverse control	BAT6	517405		
Inching pedal	BAT7	517406		
Creep gear potentiometer (accelerator pedal)	BAT8	517407		
Hydraulic pump speed sensor	BAT9	517408		
Electronics (electrical system)	D	517450-517499	or see also Electronics N	
Steering electronics	D001	516700 - 516799		0x1
Control lever electronics	D002	516500 - 516549	Joystick (right)	0xEB
			Joystick (right) (redundant)	0xED
		516550 - 516599	Joystick (left)	0x92
			Joystick (left) (redundant)	0x93



Mirror heating	R022	519922		
Potentiometer for boom monitoring	R023	519923		
Resistor	R024	519924		
Resistor	R025	519925		
Bus terminating resistance	R026	519926		
Bus terminating resistance	R027	519927		
Potentiometer for auxiliary hydraulics (joystick rocker switch)	R028	519928		
Potentiometer for 3rd control circuit (joystick rocker switch)	R029	519929		
Potentiometer (retract/extend potentiometer)	R030	519930		
DPF glow plug	R031	519931		
Heated seat	R032	519932		
Bus terminating resistance	R033	519933		
Bus terminating resistance	R034	519934		
120 Ohm resistance	R035	519935		
Levelling potentiometer	R036	519936		
Resistor module	R037	519937		
Resistor module	R038	519938		
Air intake panel heater	R041	519942		
Heating (conveying module)	R042	519943		
Heating line (pressure line)	R043	519944		
Heating line (suction line)	R044	519945		
Heating line (return line)	R045	519946		
Window heating	R046	519947		
Potentiometer lifting arm monitoring signal 2	R023.2	519948		
Heating engine ventilation	R047	519949		
Switches (electrical system)	S	518950-519299		
Preheating start switch	S001	518950		
Engine oil pressure switch	S002	518951		
Diesel engine temperature switch	S003	518952		
Pressure switch, air filter	S004	518953		
Pressure switch, hydraulic oil	S005	518954		
Temperature switch, hydraulic oil	S006	518955		
Hydraulic oil level switch	S007	518956		
Battery master switch	S008	518957		
Brake light switch	S009	518958		
Brake pressure accumulator switch	S010	518959		
Handbrake switch	S011	518960		
Steering-column control lever (left)	S012	518961		
Steering-column control lever (right)	S013	518962		
Light switch	S014	518963		
Heating switch	S015	518964		
Working light switch	S016	518965		
Working light switch	S017	518966		
Rotating beacon switch	S018	518967		
Hazard lights switch	S019	518968		

CLICK HERE TO **DOWNLOAD** THE COMPLETE MANUAL

- Thank you very much for reading the preview of the manual.
- You can download the complete manual from: www.heydownloads.com by clicking the link below



- Please note: If there is no response to CLICKING the link, please download this PDF first and then click on it.

CLICK HERE TO **DOWNLOAD** THE COMPLETE MANUAL